



PART NO. 100-1425

**INSTALLATION
INSTRUCTIONS**
**BELT KIT
1800 & 2500 TOP DRESSERS**

NOTE: Belt kit to be used only on 1800 Top Dresser, Model 44225 and 2500 Top Dresser, Model 44507.

REMOVE CONVEYOR BELT

When replacing a damaged or worn conveyor belt, always inspect hopper seals (Fig. 1) and gate edge (Fig. 1) for wear or torn edges. Replace worn or torn components to insure proper operation of new conveyor belt.

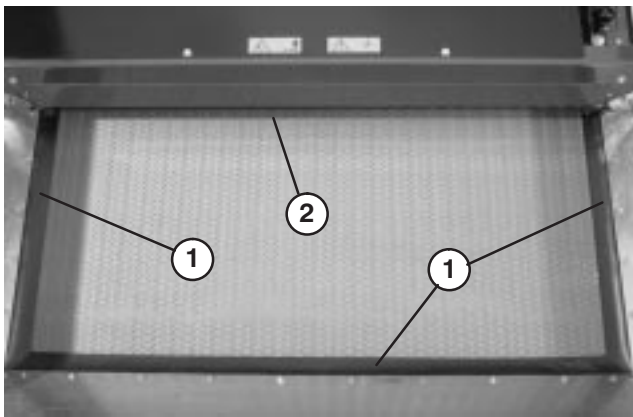
Figure 1

1. Hopper seal
2. Gate edge

1. Remove chain cover, spacer and finger guard (Fig. 2). Finger guard and spacer used only Model 44225.

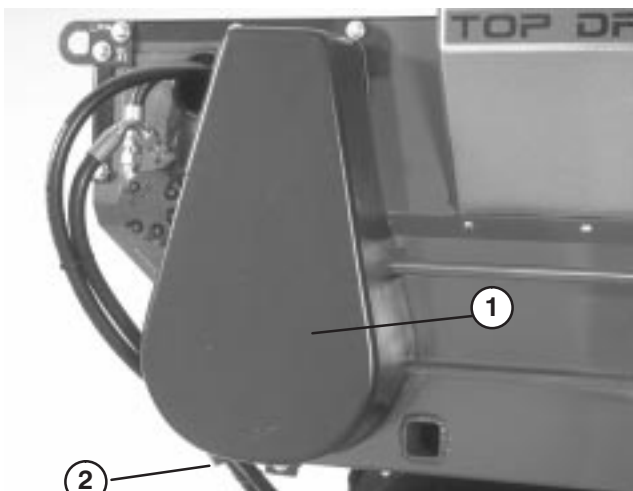
Figure 2

1. Chain cover
2. Finger guard & spacer (Model 44225 only)

2. Remove master link from chain and remove chain from small sprocket (Fig. 3).

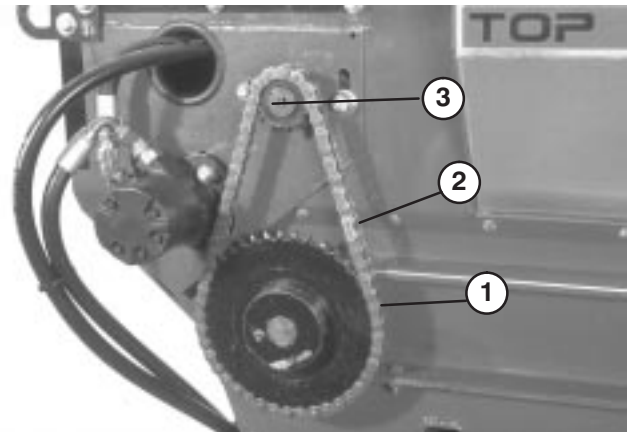
Figure 3

1. Drive chain
2. Master link
3. Motor

Note: Motor mounting bolts may have to be loosened to disassemble chain link.

3. Loosen jam nuts and nuts on tension rod to release spring tension (Fig. 4).

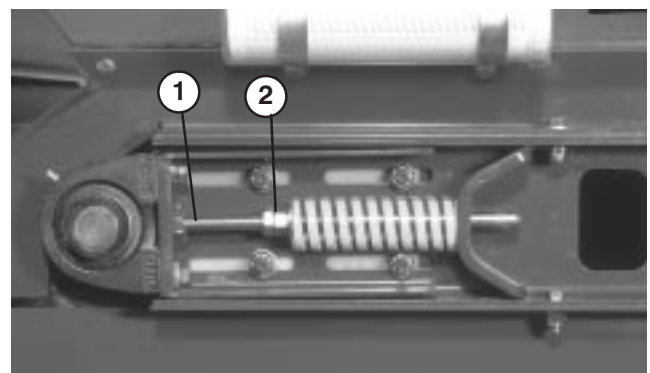
Figure 4

1. Tension rod
2. Nuts

4. Remove (2) capscrews, washers and nut, on each side of machine, securing hopper to slider bed (Fig. 5).

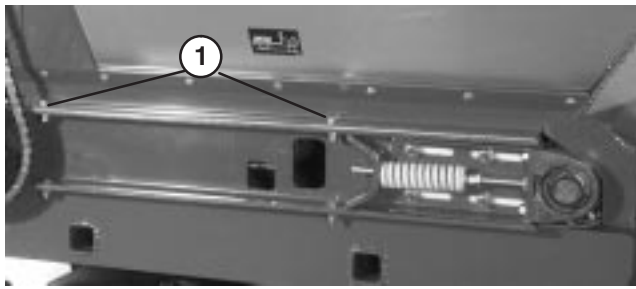

Figure 5
1. Hopper mounting cap screws
(Right side shown)

5. Pivot hopper rearward and lean against wall, ladder, etc. Do not allow hopper to rest against rear of machine as damage may result to brush or hydraulic couplers (Fig. 6).

IMPORTANT: Make sure hopper is pivoted beyond center and/or secured to wall or post to prevent it from accidentally falling on work area (Fig. 6).

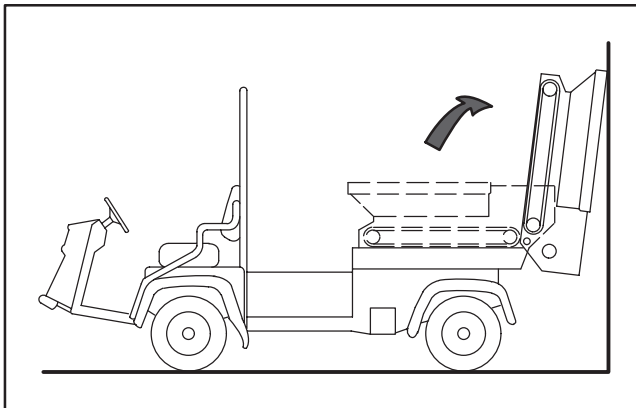

Figure 6

6. Loosen (2) cap screws, washers and nut, on right side of machine, securing slider bed to frame (Fig. 7). Make sure fasteners are loose enough to allow slider bed to be tipped.

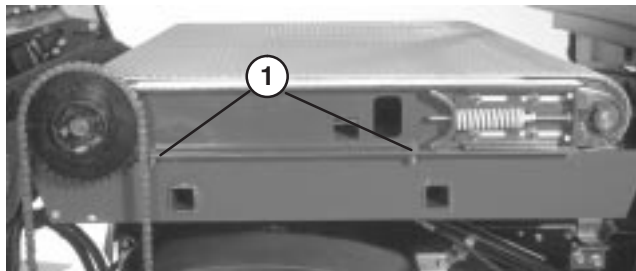

Figure 7
1. Slider bed mounting cap screws

7. Remove (2) cap screws, washers and nut, on left side of machine, securing slider bed to frame (Fig. 8).

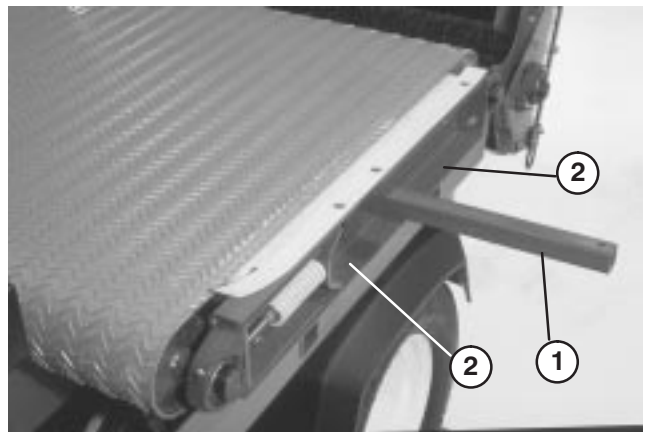

Figure 8
1. Lift bar (supplied by customer)
2. Slider bed mounting cap screws

8. To remove belt:

A. Cut belt and remove from rollers
or

B. Insert a plastic belt tool between each roller and belt. Rotate rollers until each tool is positioned to the outside of each roller. Tool must be inserted past rib in center of belt.

C. Insert a lift bar (approx. 1-1/4" x 4' rod or square tube) into hole on left side of machine.

D. Raise lift bar to tip slider bed.

E. Slide belt and belt tools off the rollers at the same time.

NOTE: If center guide of belt gets hung-up on roller groove during removal, make sure plastic tool is inserted far enough to lift belt center guide over pulley groove.

INSTALL NEW BELT

NOTE: If old belt was wavy, wrinkled or not running smoothly, check to make sure front and rear roller grooves are aligned. Also, make sure bearing lock collars are secure.

1. Insert a lift bar into hole on left side of machine and raise lift bar to tip slider bed (Fig. 8).

2. Insert belt onto rollers as far as possible.

3. Insert a plastic belt tool between each roller and belt. Rotate rollers until each tool is positioned to the outside of each roller. Tool must be inserted past rib in center of belt.

4. Slide belt and belt tools onto rollers until belt is approximately centered on rollers.

5. Remove belt tools from between belt and rollers.

6. Position belt so rib fits into alignment grooves in each roller.
7. Reverse procedure to re-assemble hopper and chain components.

ADJUST CONVEYOR BELT

When conveyor belt is adjusted properly, the compressed length of each compression spring should be 4–7/16" (112 mm). Adjust conveyor belt as follows:

1. Loosen jam nuts and adjust tension rod nuts to attain desired tension (Fig. 9).

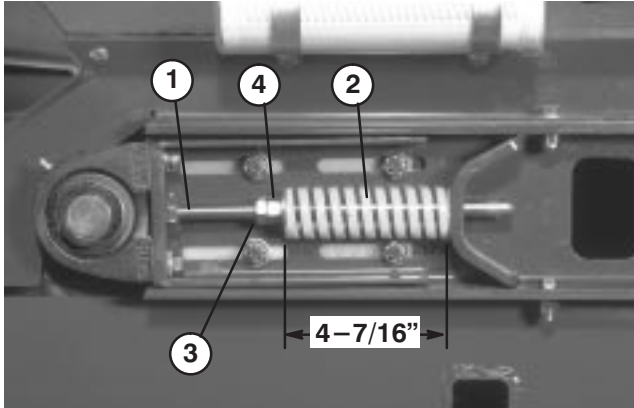

Figure 9

1. Tension rod
2. Compression spring
3. Jam nut
4. Nut

2. Tighten jam nuts to lock adjustment.
3. Check to insure that the center distance between conveyor belt roller shafts (Fig. 10), on each side of machine, are equal distance (approximately 35–1/4").

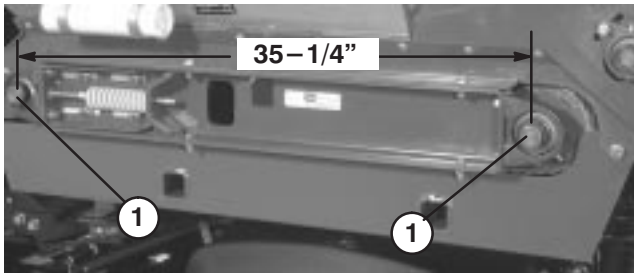

Figure 10

1. Conveyor belt roller shafts

4. Check belt operation.
 - A. If belt is slipping.
 1. Check spring tension and adjust as required.
 2. Check for broken chain or roller shaft

B. Belt has waves or wrinkles

1. Make sure roller grooves are aligned

SAND PRECAUTIONS

The Topdresser is equipped with a flexible gate edge (Fig. 11) and spring release mechanism to reduce the chance of sand chunks or rocks getting lodged during operation. To insure long belt life, sift or check sand for rocks with sharp edges that may damage conveyor belt.

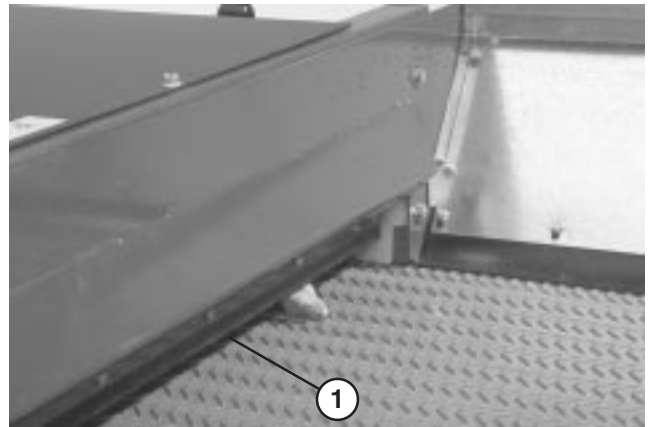

Figure 11

1. Gate edge

COLD WEATHER OPERATION

The Topdresser may be used in cold weather, with certain limitations, to apply a salt/sand mixture on pavement for ice control. The PVC conveyor belt material becomes very stiff in cold weather and requires more power to operate belt. The life of the belt is reduced by approximately 50% when operated below temperatures of 40° F (5° C). **Under no conditions should the topdresser be operated below temperatures of 20° F (-7° C).**

1. Increase belt tension by adjusting spring compression to 4 inches (101 mm). Refer to Adjust Conveyor Belt.
2. Always run belt, before adding material, to assure moisture has not frozen belt system. Damage to belt or roller may occur if belt/drive roller slip.

IMPORTANT: Always re-set belt tension to normal 4–7/16" (112 mm) spring compression adjustment before operating topdresser under normal temperature conditions.

