



Count on it.

Parts Catalog

Trencher Head

TXL 2000 Tool Carrier

Model No. 22533—Serial No. 318000001 and Up



Trencher Head Assembly

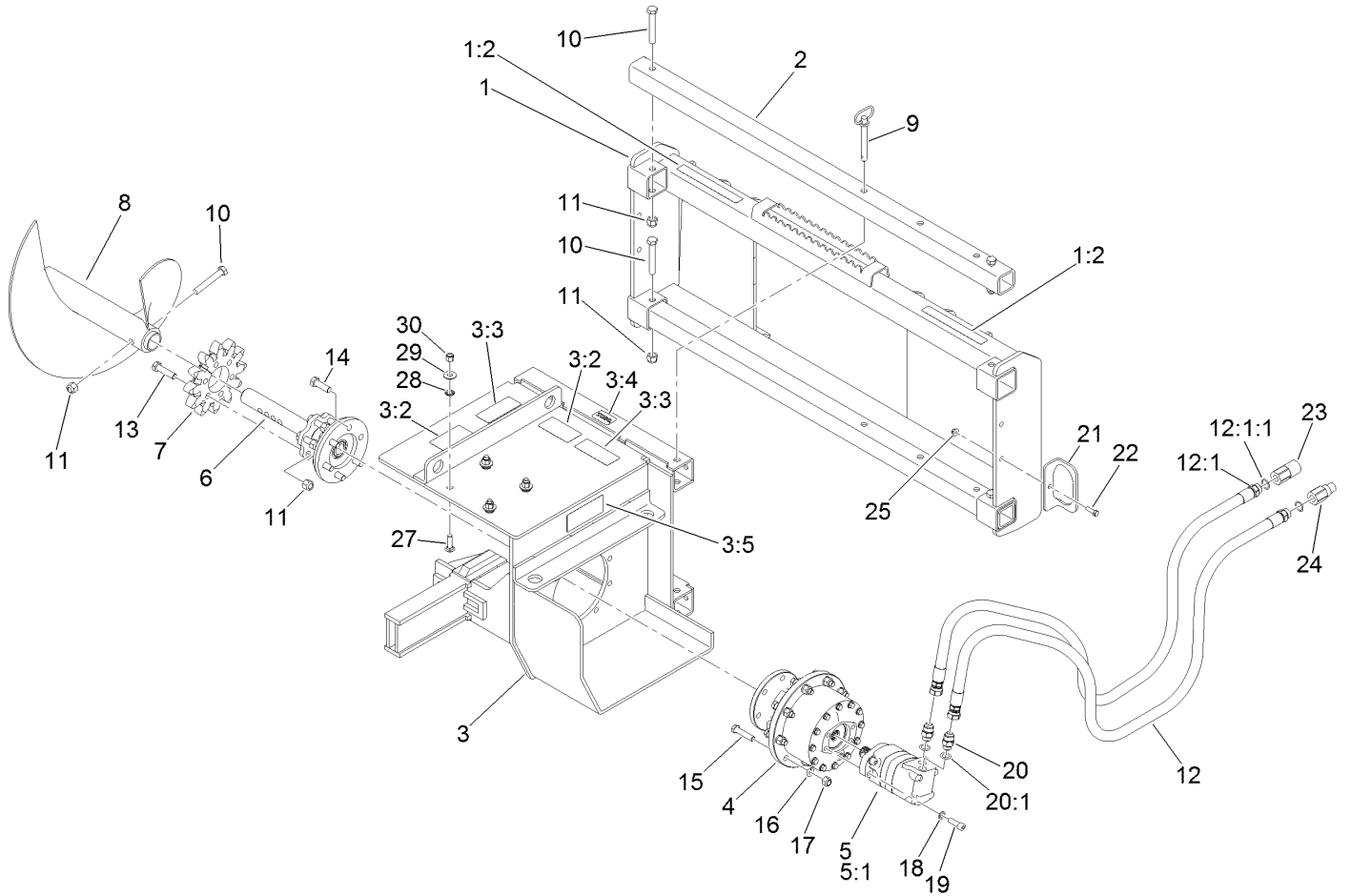

Trencher Head Assembly (continued)

<i>Ref.</i>	<i>Part Number</i>	<i>Qty.</i>	<i>Description</i>	<i>Ref.</i>	<i>Part Number</i>	<i>Qty.</i>	<i>Description</i>
1	139-2780	1	Frame ASM	12:1:1	237-81	1	O-Ring
1:2	139-2804	2	Decal-Danger	13	327-7	6	Screw-HH
2	137-8918	2	Tube-Adjustment	14	327-6	6	Screw-HH
3	139-2779	1	Head Frame ASM	15	119-1042	9	Screw-HH
3:2	131-0711	2	Decal-Warning	16	137-8944	9	Washer-Lock
3:3	131-2539	2	Decal-Danger	17	99-4371	9	Nut-Lock
3:4	98-3206	1	Decal	18	3253-7	4	Washer-Lock
3:5	125-6128	1	Decal-Warning	19	3274-4	4	Screw-HSH
4	137-8922	1	Planetary ASM	20	01-201-3290	2	Fitting-Straight
5	137-8923	1	HYD Motor ASM	20:1	237-80	1	O-Ring
5:1	139-1406	1	Seal Kit	21	137-8936	1	Guide-Hose
6	137-8924	1	Shaft-Drive	22	323-7	1	Screw-HH
7	137-8925	1	Sprocket-Drive	23	137-9006	1	Fitting-Adapter
8	137-8928	1	Auger-Spoil	24	137-9007	1	Fitting-Adapter
9	137-8943	1	Pin-Hitch	25	104-8301	1	Nut-HF, NI
10	HDW01706	5	Screw-HHCS	27	3233-14	4	Screw-CARR
11	3296-53	11	Nut-Lock, NI	28	1-323142	4	Nut-Push
12	137-9019	2	Hose ASM	29	3256-6	4	Washer-Flat
12:1		1	Fitting-Straight ●	30	3296-23	4	Nut-Lock, NI

● Not serviced separately