



Multi-Core Aerators

MC 10, MC 15 and MC 20

Model No. 09697–90001 & Up

Model No. 09698–90001 & Up

Model No. 09699–90001 & Up

PROTOTYPE

Operator's Manual

TABLE OF CONTENTS

SERIAL No. LOCATION	3
INTRODUCTION	4
Intended Use	4
Principles of Operation	4
SAFETY	5
General Safety	5
Operating Safely	5
Transport Safety	6
Storage Safety	6
Maintenance & Adjustment Safety	6
Safety Decals	7
Pictorial Decals	7
PTO Shaft Safety	8
Sign-off Form	9
OPERATING YOUR AERATOR	10
Principle Components	10
Tractor Requirements	11
Tractor Attachment	11
Tine Selection	12
Core Windrower	12
Field Operation	13
Turf Holder Adjustment	13
Tine Depth Adjustment	13
Operating	14
MAINTENANCE	15
General	15
Lubrication	15
Lubricant Specifications	15
Lubrication Intervals	15
Drive Belts	15
Belt Adjustment	15
Belt Replacement	17
Storage	17
Fasteners	18
TROUBLESHOOTING	19
SPECIFICATIONS	19
WARRANTY	20

SERIAL NUMBER LOCATION

For your convenience, record the Serial Number and the Date purchased in the spaces provided below. Have this information before you call your Toro dealer. You will find the aerator's identification plate inside the hood on the body of the machine.

MODEL:
SERIAL No.:
DATE OF DELIVERY:

Fig. 1.

THE MANUAL

Keep this manual handy for frequent reference and to pass on to new operators and owners. Call The Toro Company or their distributors if you require assistance, information or additional copies of the manuals. After reviewing this manual, store it in a dry, easily accessible location for future reference.

OPERATOR'S ORIENTATION

The directions left, right, front and rear as mentioned throughout this manual are as seen from the rear of the machine facing toward the direction of travel.

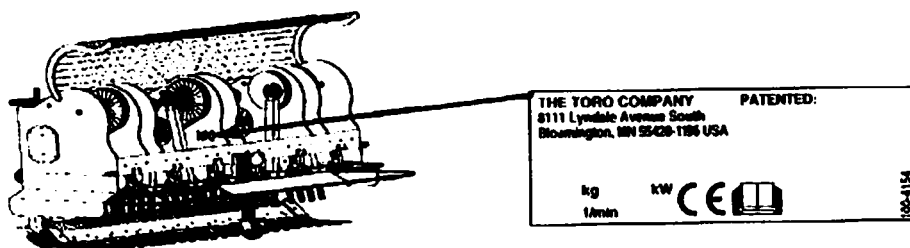

Fig. 2.

IDENTIFICATION PLATE LOCATION

Accompanying this manual is a manufacturer's warranty registration certificate. Please complete this form upon delivery and return to the seller within 15 days to validate your warranty. Please note, warranty is void if not registered.

Introduction

Congratulations on your choice of an aerator from The Toro Company to complement your turf care operation. This machine has been designed and manufactured to meet the needs of a discerning turf care industry.

For your safety and to aid in developing a better understanding of your machine, all operators must read the operators' sections of this manual. The parts sections are for reference only and do not require thorough reading.

The parts on your aerator have been specifically designed to give a highly reliable and long life. Only The Toro Company or their representatives can offer you the genuine parts. If other spurious parts are used, we are unable to guarantee the performance or safety of this machine and your warranty will be invalidated.

INTENDED USE

Your aerator has been designed and constructed for a specific use with exacting standards and sound engineering principles.

If this machine is not used exclusively for its intended purpose, safety is in jeopardy and the expected trouble-free working life of the machine may be reduced.

This aerator is intended to aerate fine turf surfaces (golf and bowling greens for example) by using a series of hollow or solid tines which are driven into the turf surface up to a depth of 125mm (5 inches).

Due to the intrinsic hazards of machinery of this type when used with today's sophisticated tractors, this aerator should only be attached and used by qualified personnel with sufficient experience who are fully conversant with the tractor.

PRINCIPLES OF OPERATION

This aerator is mounted on a tractor's three-point linkage to lift and lower the machine out of and into work, or for transport.

The tractor's power take-off (PTO) power is transmitted via shafts, gearbox and drive belts to crankshafts that

drive the tine holding con-rods into the turf surface.

As the tractor travels forward with the PTO engaged and the machine lowered, a series of holes or slits are created in the turf surface.

The depth of the tines' penetration is determined by the height of the depth control roller.

The distance between the holes created is determined by the tractor's forward speed and the number of tines in each tine head.

Safety

GENERAL SAFETY

WHY IS SAFETY IMPORTANT TO YOU?

- ACCIDENTS DISABLE & KILL
- ACCIDENTS COST
- ACCIDENTS CAN BE AVOIDED

Owners of this aerator are obliged to give operators and employees full operation and safety instructions before allowing them to operate this machine and at least annually thereafter. An operator who has not read and fully understood all operating and safety instructions is not qualified to operate this machine. Do not modify this machine in any way. Unauthorized modification may impair the function and/or safety and could affect the life of the equipment and invalidate the warranty.

OPERATING SAFELY

REFER TO THE SAFETY INSTRUCTIONS IN THE TRACTOR MANUAL

Your aerator has been designed and built to reduce exposure or risk to the operator and bystander. However, no one should operate this machine without understanding the contents of this manual.

1. DO NOT allow anyone to operate this machine who has not been properly trained in its safe operation. DO NOT allow children to operate this machine.
2. NEVER allow passengers.
3. ALWAYS be certain the tractor is in neutral and handbrake applied before starting (see tractor manual for safe starting procedures).
4. Keep hands, feet, hair and clothing away from moving parts. Wear appropriate gear.

This list includes but is not limited to:

- A hard hat.
- Protective shoes with slip resistant soles and steel toe caps.
- Protective glasses or goggles.
- Heavy gloves.

- Wet weather gear.
 - Hearing protection.
 - Respirator or filter mask.
5. BEFORE aerating an area, walk the site and clear the area of any objects or debris.
 6. To maintain full steering control, add front-end weights to your tractor. To determine the amount of additional front-end weights, refer to your tractor manual.
 7. BEFORE making ADJUSTMENTS or performing maintenance on the aerator, switch off the engine and apply the handbrake before dismounting from the tractor. Be sure the aerator is on the ground or lowered onto the rear castor/safety stand.
 8. ALL GUARDS and shielding must be in place and secure. Only authorized, competent staff should remove any guarding.
 9. The area to be aerated should be clear of all bystanders.
 10. When operating near ditches or bunkers be alert that with ground disturbance, sides may be caused to collapse.
 11. Do not smoke when refuelling. Do not allow others to smoke.
 12. After striking an object, switch off the tractor and inspect for any damage before continuing.
 13. After completing an area, always check that any missing tines are found, and that new tines are fitted.
 14. Never dismount while the tractor is in motion. Never get on or off the tractor while the engine is running and the PTO driveshaft is engaged. Never step over the PTO driveshaft to reach the other side of the aerator—walk around the machine.
 15. Look behind the aerator before backing up.

16. Reduce speed on side hills and before making short turns to prevent tipping or loss of control.

TRANSPORT SAFETY

1. Be sure you are in compliance with all regulations regarding transporting equipment on the public roads and highways.
2. Ensure that all reflectors and lights required are in place and are clean and visible to overtaking and oncoming traffic.
3. Do not allow anyone to ride on the machine during transport.
4. REDUCE SPEED on rough roads and surfaces.
5. Independent brakes should ALWAYS be locked together when on the road.

STORAGE SAFETY

1. Store your aerator on a firm, level surface.
2. Store away from areas of human activity.
3. DO NOT allow children to play on or around the stored machine.
4. Make sure the aerator is sitting, or blocked up firm and solid and will not sink into soft ground causing it to tip.
5. Ensure that the rear stand pin is secured in place.
6. Block the aerator to prevent it from rolling or tipping.

MAINTENANCE AND ADJUSTMENT SAFETY

1. Follow all the maintenance and safety information in this manual.
2. Support the machine with the rear castor safety stand when working beneath it. NEVER rely on the tractor's hydraulics to support the machine.
3. Place all controls in neutral, stop the engine, apply the handbrake and wait for all moving parts to stop

before servicing, maintaining, adjusting or unblocking your aerator.

4. Follow good workshop practices. Keep service areas tidy, clean and dry.
 - Be sure electrical outlets and tools are properly grounded and protected.
 - Use adequate light for the job.
5. Do NOT check or adjust belt tension when the tractor engine is running.
6. Be sure all guards are replaced and the hood is secured shut after maintaining or adjusting the machine.
7. Keep hands, feet, hair and clothing away from moving or rotating parts which may move even when not connected to the tractor.
8. NEVER wear ill-fitting, baggy or frayed clothing when working on or around any of the drive system components.
9. ALWAYS ensure the hydraulics are in their lowest position and the aerator is resting on the roller or rear castor/safety stand before leaving the tractor for adjustment or inspection.

SAFETY DECALS

Your aerator comes equipped with all safety decals in place. They were designed to help you safety operate this machine by bringing your attention to potential hazards.

Read and follow their directions.

1. Keep all safety decals clean and legible.
2. Replace all damaged or missing decals. To order new decals, call your local Toro distributor with the correct decal part number.
3. Refer to this section for correct positioning of the decals. To install new decals:
 - a. Thoroughly clean the painted area of dust and grease.

- b. Peel the backing from the decal. Starting from the top, press firmly onto the surface being careful not to cause air bubbles under the decal.

PICTORIAL DECALS

The decals that provide warnings pictorially are described as follows. The color of pictorial decals indicate their level of hazard

RED = DANGER

ORANGE = WARNING

YELLOW = CAUTION



CAUTION!: Read the operator's manual before operating, maintaining or adjusting this machine.



CAUTION!: Stop the tractor and remove the key. Always consult the manual before attempting maintenance or adjustments.

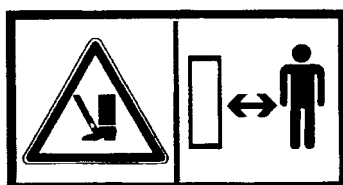

WARNING!: Lower limb and foot hazard. Keep your distance from the machine.

PTO SHAFT SAFETY



Fig. 3

For any PTO shaft, steel parts (tubes, bearings, joints etc), disassembly or repairs, it is highly advisable to contact your local Toro distributor. Removal of components for repairs and reassembly may damage some parts if not carried out correctly using special tools available in a dealer's workshop.

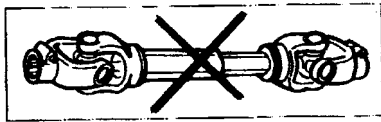

Fig. 4

The PTO shaft should not be used:

- Without the guards supplied
- With partial protection
- With damaged guards.

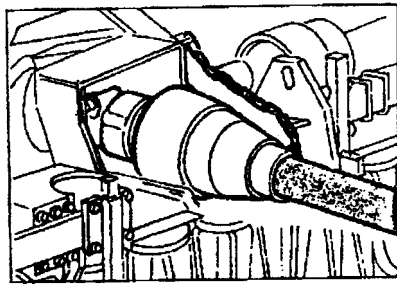

Fig. 5

The PTO shaft should not be used without the special anti-rotation chains correctly hooked, so as to permit the maximum angle of the PTO shaft without breaking the chains.

SIGN-OFF FORM

Anyone who will be operating the aerator must read and clearly understand ALL safety, operating and maintenance information in this manual.

Do not operate or allow anyone else to operate this equipment until such information has been reviewed. Annually review this information before the season start-up.

Make these periodic reviews of SAFETY and OPERATION a standard practice for all your equipment. An untrained operator is unqualified to operate this machine.

A sign-off sheet should be provided for your record keeping to show that all personnel who will be working with the equipment have read and understand the information in the operator's manual and have been instructed in the operation of the equipment.

Principal Components

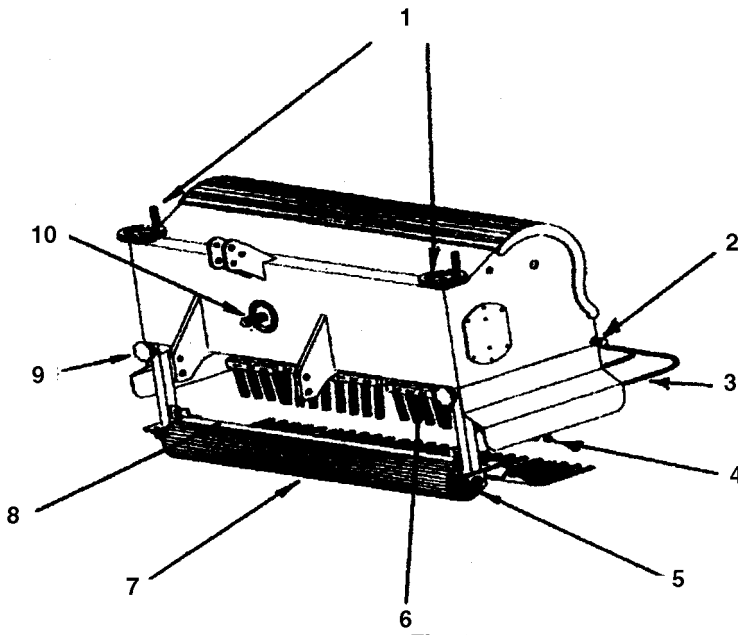

Fig. 6

- | | |
|-------------------------------|-------------------------|
| 1. Depth adjustment handles | 6. Tine head |
| 2. Windrower attachment point | 7. Depth roller |
| 3. Lower limb guarding | 8. Roller scraper |
| 4. Tine | 9. Depth locking handle |
| 5. Roller bearing | 10. PTO input shaft |

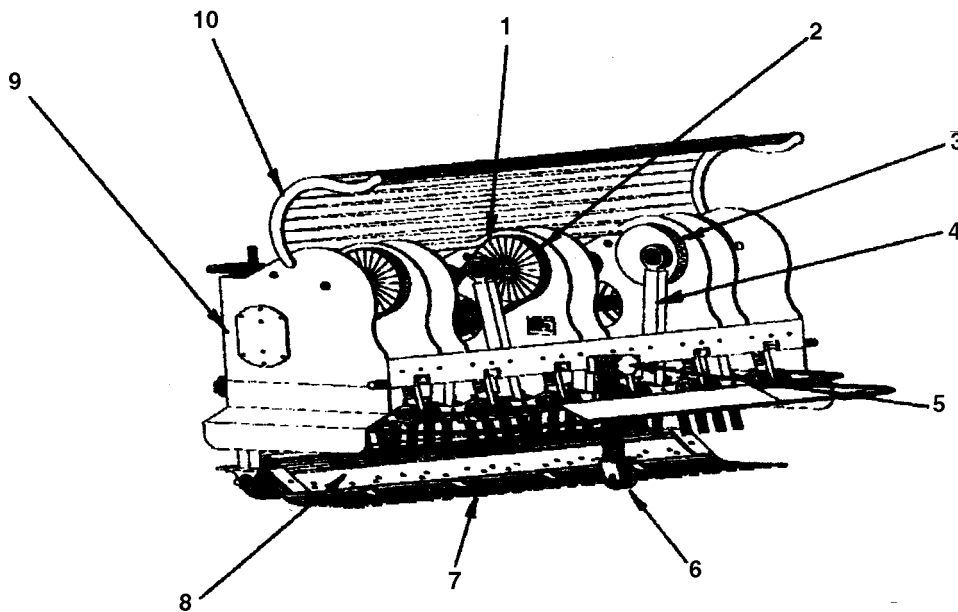

Fig. 7

- | | |
|-------------------------------------|-----------------------------|
| 1. Drive belt | 6. Rear castor/safety stand |
| 2. Pulley | 7. Turf holders |
| 3. Fly wheel | 8. Turf holder bracket |
| 4. Con rod | 9. Main body |
| 5. Castor/safety stand locking knob | 10. Hood |

TRACTOR REQUIREMENT

Your aerator is designed for tractors with category one 3-point hitch. Horsepower requirements are as shown in the table below.

MODEL	TRACTOR H.P.(KW)
MC 10	16 H.P. (11.5)
MC 15	24 H.P. (17.5)
MC 20	32 H.P. (23)

Adequate front-end weight is required to maintain good front-wheel-to-ground contact for steering control and tractor stability. Refer to your tractor manual and the Specifications section 6.0 at the back of this manual for the weight of the aerator.

TRACTOR ATTACHMENT

1. Be sure the area around the implement is clear of people and children and that you have enough room to manoeuvre.
2. Reverse slowly and squarely to the aerator with lower link arms lowered to the height of the lower link hitch pins of the aerator.
3. When the left-hand link arm is aligned with the hitch pin on the aerator, STOP THE ENGINE, ENGAGE THE HANDBRAKE, DISENGAGE THE GEAR—Push the link arm over the linkage pin, put the retaining lynch pin in position and secure.
4. Adjust the height of the right-hand link arm as necessary to align it with the linkage pin. Attach and secure it with the retaining lynch pin.
5. Adjust the top link length with the turnbuckle to align link holes, place in pin and retaining lynch pin.

Reduce or increase the length of the top link to adjust the machine to stand vertical (fig 8). Use the tractor levelling box so that the machine is lifted evenly when viewed from front or rear.

7. Connection of PTO:

- (a) Ensure that the securing pin is fully released

and locked onto the PTO stub shaft securing the connection (fig 9).

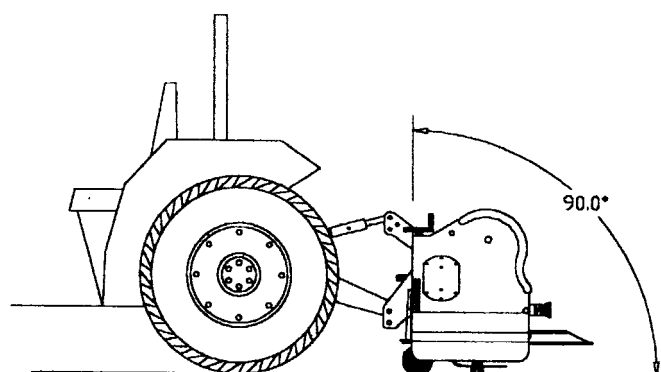

Fig. 8

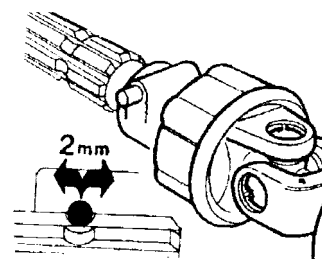

Fig. 9

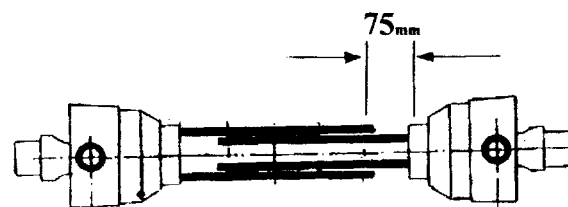

Fig. 10

- (b) Ensure that there is approximately 75mm (3 inches) of clearance of the tubes and guards (fig. 10). If not, cut both sections to length with a hacksaw and use a round file to debur.
8. Adjust the length of the lower linkarm stabilizer chains so that the aerator is secured at the centre point of the tractor and cannot swing from side to side.
 9. Ensure that when the machine is lifted on the linkage that no part comes in contact with the tractor.

10. On smaller compact tractors, front-end weights or front-wheel ballast may be necessary to ensure full tractor stability and prevent backward tractor turnover.

11. To demount the machine, find a level hardstanding area and carry out the above procedure in reverse.

TINE SELECTION

Your aerator is available with a wide selection of tines and tine heads. Choose your tine type size and spacings required, then change the tine head accordingly.

TINE SIZES				
TUBULAR HOLLOW	OPEN SIDED (WINDOW) HOLLOW	SOLID	CHISEL	SLICING
10mm	5mm mini	5mm needle	6mm	3mm
13mm	16mm	9mm	8mm	
16mm		9.5mm mini		
		10mm		
		11mm		
		13mm		
		16mm		

AERATION PATTERN: VARIABLE, DEPENDING ON TINE HEAD AND FORWARD SPEED

MINI TINE HEAD	30mm TINE SPACINGS X 25mm - 100mm
NEEDLE TINE HEAD	40mm TINE SPACINGS X 25mm - 60mm
STANDARD TINE HEAD	61mm TINE SPACINGS X 30mm -130 nun
FAIRWAY TINE HEAD	81mm TINE SPACINGS X 30mm -130mm

Different turf holders are required for 3, 4 and 8 tine heads.

CORE WINDROWER

If using hollow tines, your aerator is available with a windrower assembly to place cores in narrow rows behind the machine. Attach the windrower as shown below.

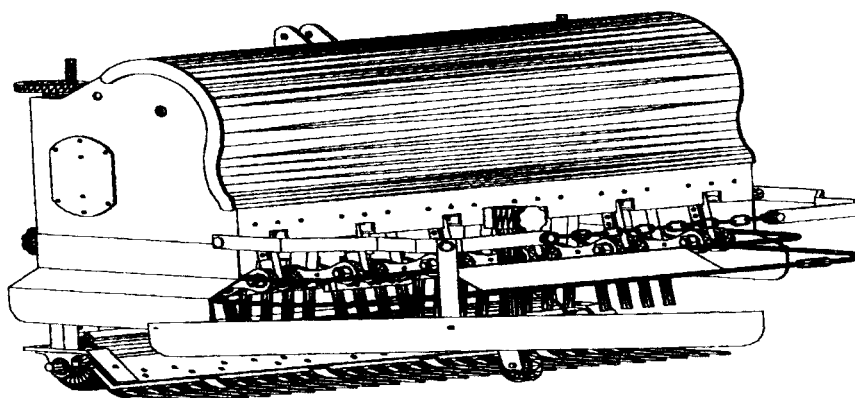

Fig. 11

Ensure all clips are secured. The chain length may be adjusted using two 17mm wrenches to give different widths of windrow as required.

FIELD OPERATION



WARNING

Clear the area to be aerated of all bystanders. No-one should be within 20 meters of this machine or tractor.

TURF HOLDER ADJUSTMENT

Before starting your new aerator, remove the rear castor stand. Lower the machine on the 3-point linkage until the depth control roller is resting on the ground. From the rear of the machine, check that the tines line up exactly with the center of the gap in the "Turf Holder" fingers. Adjust the turf holders if necessary. To adjust the turf holders, slacken the three bolts holding the turf holder using a 17mm wrench. Move the turf holder to the required position so that each tine enters the ground directly between each finger, and that the fingers trail in a straight line under the machine.

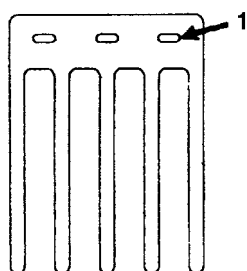

Fig. 12

1. Elongated slots allow alignment of fingers

Turf with a good root structure may not require the turf holders. If this is the case, **DO NOT REMOVE THE TURF HOLDER BRACKET** as this adds support to the roller leg assembly. Just remove the plastic fingers from the turf holder bracket.

TINE DEPTH ADJUSTMENT

To adjust the working depth of the tine (Fig. 14).

1. Release the two locking off handles one and a half turns (counter-clockwise).
2. Turn the height adjuster handles to raise (deeper) or lower (shallow) the roller.

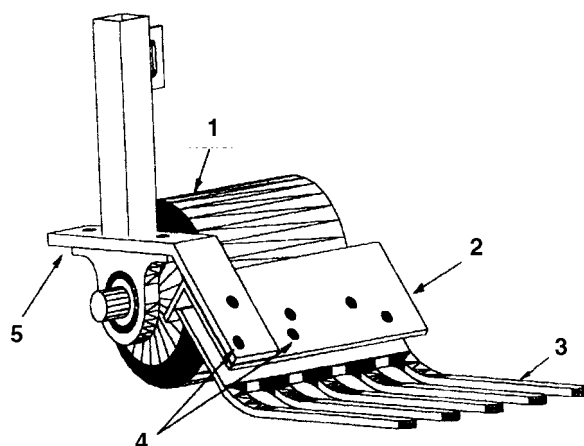

Fig. 13

1. Roller
2. Turf finger Bracket
3. Plastic turf finger
4. Mini-tine turf finger holes
5. Roller foot

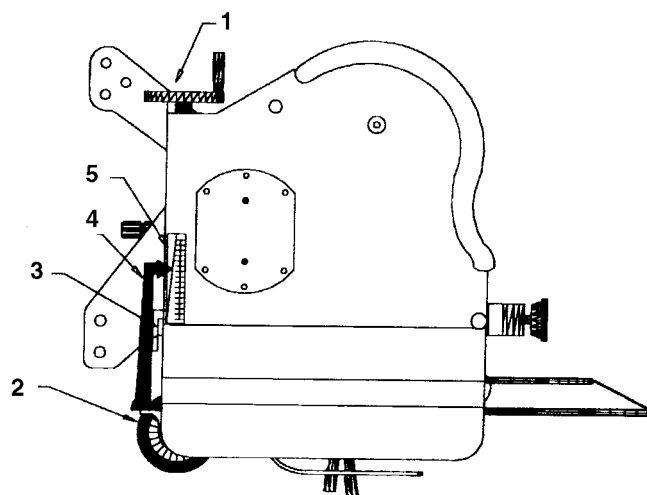

Fig. 14

1. Adapter handle
2. Roller
3. Locking handle
4. Pointer
5. Depth scale

Guides are given from 1–27. The numbers do not relate to measurements of depth as this alters with tine type and amount of tine wear. Adjustment between two numbers will give approximately 5mm change in depth. The higher the number, the deeper the tine penetration.

IMPORTANT: If a large change in height is required, adjust each leg by a small amount to ensure the roller legs are adjusted as evenly as possible.

NOTE: Remember when depth changes are made, you will need to adjust your top link length to give the correct machine angle.

SPEED.

4. Re-tighten the locking off handles before running the machine, even if you are just testing for correct depth.

OPERATING

When first operating the machine, you may wish to try your first run on a practice area to allow the operator to become familiar with the operation.



WARNING

Clear the area of all bystanders.

NOTE: Always use the machine in straight lines for best results.

1. Lower your aerator on the 3-point linkage so that the tines are not touching the ground at the lowest part of their stroke.
2. Engage the power take off (PTO) clutch to start your aerator working.

IMPORTANT: Do not operate your Aerator at 540 rpm when lifted out of the ground. This machine can be damaged if operated at full speed without the tine working in the turf.

3. Select a gear that gives a forward speed of approximately 1 to 4 km/hr at (see tractor manual) rated PTO speed.
4. As the clutch is released and the tractor moves forward, lower the machine fully into work AND increase engine speed to give a maximum of 540 rpm at the PTO.
5. Note the hole pattern. If you require greater hole spacing increase forward speed of the tractor by changing up a gear or with a hydro-static drive tractor shift, the hydrostat lever or pedal to give faster speed. For closer hole spacing, decrease tractor forward speed. DO NOT CHANGE ENGINE

Maintenance

Proper servicing and adjustment is the key to the long life of any machine. With careful and systematic inspection you can avoid costly repairs and time.

GENERAL

After using your aerator for four hours, check all bolts and fasteners are tight.

LUBRICATION

The main working bearings of this aerator are sealed for life and require no maintenance or lubrication. This drastically reduces the maintenance required and eliminates the risk of grease or oil being dropped onto your turf.

LUBRICANT SPECIFICATIONS

GREASE: Use an SAE multi-purpose, high-temperature grease with high pressure (EP) performance. Also acceptable is an SAE multi-purpose lithium base grease.

GEARBOX LUBRICATION: Use 85/140 gear oil or equivalent.

LUBRICATION INTERVALS

The following lubrication and checks are required.

EVERY 6 MONTHS OR 100 HOURS OPERATION

ROLLER BEARINGS—1 PUMP GREASE.

DEPTH JACKS—2 PUMPS GREASE.

DRIVE SHAFT BEARINGS—1 PUMP GREASE.

GEARBOX—Check oil level reaches the level plug at the rear of the gearbox. Top up as required

DAILY

PTO SHAFT—Grease as indicated below



Fig. 15

DRIVE BELTS

The drive belts serve two purposes:

1. To transmit the power to the crankshaft pulley.
2. To provide drive line protection by slippage when the machine is overloaded by dry ground conditions or sub-surface stones are encountered.

The drive belts may require adjustment within the first 10 hours of operation and thereafter as required when excessive belt slippage is experienced.

BELT ADJUSTMENT

The type of link belt used on this machine allows for easy adjustment or replacement without the use of idler tensioners, which absorb horsepower and reduce belt life. If excessive slippage is experienced, follow this procedure to shorten the belts.

LEVER THE BELT FROM THE PULLEY.

IMPORTANT: Turn the belt inside out (As shown) To Ensure Easy Assembly and Disassembly

DISASSEMBLY

1. Hold belt upside down. Bend back as far as possible. Hold with one hand. Twist one tab 90 degrees parallel with slot.

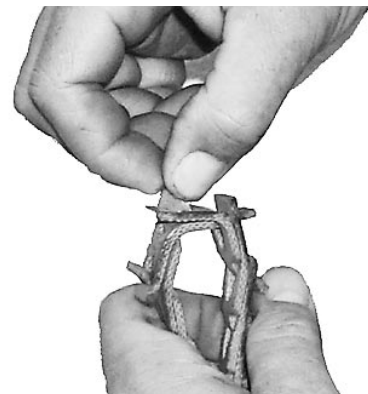

Fig. 16

2. Pull the end of the link over the tab (Fig. 17).



Fig. 17

3. Rotate belt end with tab 90 degrees



Fig. 18

4. Pull belt end through two links. REMOVE A LINK TO SHORTEN BELT.

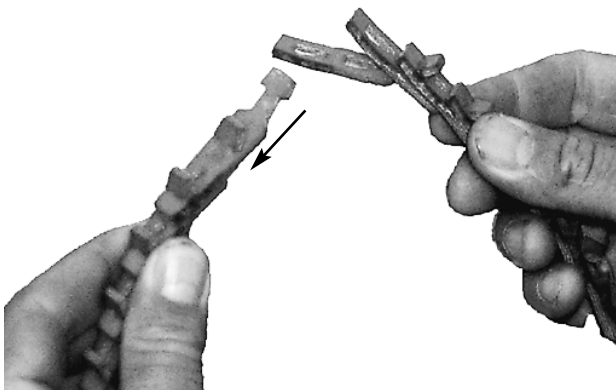

Fig. 19

ASSEMBLY

1. Hold the belt with tabs pointing outward

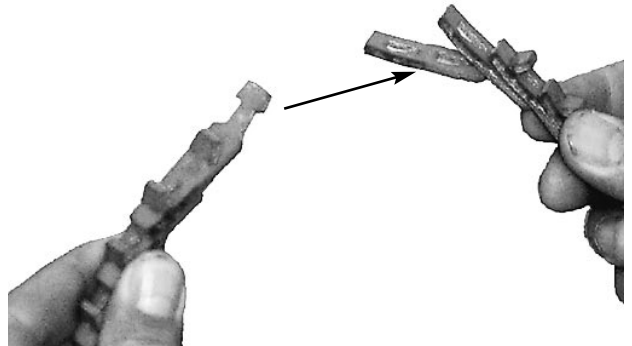

Fig. 20

2. Place the end tab through two links at once

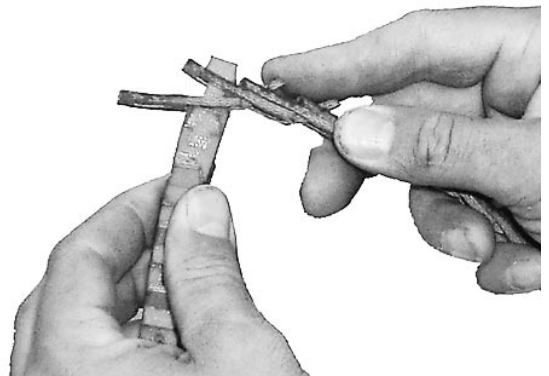

Fig. 21

3. Flex the belt further and insert the second tab through the end link by twisting the tab with your thumb



Fig. 22

4. Ensure the tab returns to its position across the belt. Reverse the belt so the tab runs inside



Fig. 23

INSTALLATION

1. Turn the belt with tabs to the inside before installing.
 2. Determine the direction of drive rotation.
 3. Align the belt's directional arrow with drive direction (i.e., top of belt points to rear of machine).
 4. Fit the belt in the nearest groove of the smaller drive pulley.
 5. Roll the belt onto the larger sheave, turning the drive slowly. The belt may seem very tight; this is okay.
 6. Make sure all tabs are still in their correct position and are not twisted out of alignment.
1. Clean off any dirt or grease that may have accumulated on the aerator or any of the moving parts.
 2. Remove the tines and clean out hollow tines.
 3. Open the hood and clean out the inside of the machine.
 4. Lubricate as indicated in 4.2 (Lubrication).
 5. Remove belting from the pulleys to remove tension and avoid stretching.
 6. Store the machine with the roller standing on a hard, dry surface or board and block the castor wheel.
 7. Paint the roller and touch-up any scratches on the paintwork.
 8. Replace any missing decals.
 9. Store the Aerator inside a dry secure building away from human activity. Inside storage will reduce maintenance, give a longer working life and increase the residual value of your machine. If inside storage is not available, cover with a heavy sheet or tarpaulin and secure tightly.
 10. Order any parts which require replacement following your inspection so that you have them for the start of next season.

BELT REPLACEMENT

If the belts become worn, replace them with genuine belting using the procedure in Belt Adjustment.

STORAGE

At the end of an aerating season or when your aerator will not be used for a long period, it is good practice to carry out the following preventative maintenance.

FASTENERS

CHECKING BOLT TORQUE

The table shown below gives correct torque values for various bolts and capscrews. Tighten all bolts to the torques specified in chart unless otherwise noted. Check tightness of bolts periodically, using bolt torque chart as a guide. Replace hardware with the same strength bolt.

METRIC TORQUE SPECIFICATIONS

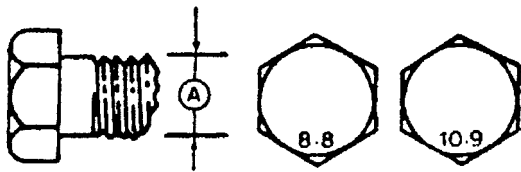

Fig. 24

Bolt dia.	TORQUE SETTING			
	8.8		10.9	
"A"	Nm	lb-ft	Nm	lb-ft
M3	0.5	(4)	1.8	(1.3)
M4	3	(2.2)	4.5	(3.3)
M5	6	(4)	9	(7)
M6	10	(7)	15	(11)
M8	25	(18)	35	(26)
M10	50	(37)	70	(52)
M12	90	(66)	125	(92)
M14	140	(103)	200	(148)
M16	225	(166)	310	(229)
M20	435	(321)	610	(450)
M24	750	(553)	1050	(774)
M30	1495	(1103)	2100	(1550)
M36	2600	(1917)	3675	(2710)

Troubleshooting

Problem	Cause	Solution
Irregular hole pattern	Forward speed not constant. Engine speed not constant. Belt slippage	Set hydro-control. Set hand throttle Adjust belt tension
Machine bounces	Ground too hard Subsurface debris Working too deep	Irrigate Reduce working depth Reduce depth
Slotted holes	Ground too wet & soft Too fast forward speed Incorrect top link length	Wait Reduce gear & reduce spacing Try shortening top link
Hollow tines blocking	Are you using genuine tines? Too wet for soil type Using wrong tines	Call your Toro dealer Wait Call your Toro dealer - Use side eject tines
Belts slipping	Loose belts	Remove link

Specifications

SPECIFICATIONS	MC10	MC15	MC20
Work Width (cm)	100cm	150cm	200cm
Overall Width (cm)	128cm	178cm	228cm
Overall Length (cm)	98cm	98cm	98cm
Overall Height (cm)	98cm	98cm	98cm
Number of Tine Heads	4.0	6.0	8.0
Weight (Kg)	400Kg	525Kg	650Kg
PTO Speed (RPM)	540.0	540.0	540.0
Power requirement HP/KW	16/11.5	24/17.5	32/23
Hitch Category	CATEGORY 1	CATEGORY 1	CATEGORY 1
Min/Max Depth (mm)	0-125mm	0-125mm	0-125mm

FIGURES ABOVE EXCLUDE WINDROWER ATTACHMENT

The Toro Commercial Products One-Year Limited Warranty

Your Multi-core by Toro (Model #09697, 09698, or 09699) ("Product") is warranted to be free from defects in materials or workmanship for the period of time listed below. Where a warrantable condition exists, Toro will repair the Product at no cost to you including diagnosis, labor, parts, and transportation. This warranty begins on the date the Product is delivered to the original retail purchaser.

Warranty Duration: One year or 500 operational hours*, whichever occurs first.

***Product equipped with hour meter**

Owner Responsibilities:

As the Product owner, you are responsible for required maintenance and adjustments stated in your Owner's Manual. Failure to perform required maintenance and adjustments can be grounds for disallowing a warranty claim.

Instructions for Obtaining Warranty Service:

You are responsible for notifying the Commercial Products Distributor or Authorized Commercial Products Dealer from whom you purchased the Product as soon as you believe a warrantable condition exists.

If you need help locating a Commercial Products Distributor or Authorized Dealer, or if you have questions regarding your warranty rights or responsibilities, you may contact us at:

Toro Commercial Products Service Department
8111 Lyndale Avenue South
Minneapolis, MN, 55420-1196
Telephone: (612) 888-8801
Facsimile: (612) 887-8258
E-Mail: Commercial.Service@Toro.Com

Maintenance Parts:

Parts scheduled for replacement as required maintenance ("Maintenance Parts"), are warranted for the period of time up to the scheduled replacement time for that part.

Items/Conditions Not Covered:

Not all product failures or malfunctions that occur during the warranty period are defects in materials or workmanship. The items/conditions listed below are not covered by this warranty:

- Product failures which result from the use of non-Toro replacement parts, or from installation and use of add-on, modified, or unapproved accessories are not covered.
- Product failures which result from failure to perform required maintenance and/or adjustments are not covered.
- Product failures that result from operating the Product

in an abusive, negligent or reckless manner are not covered.

- This warranty does not apply to parts subject to consumption through use unless found to be defective. Examples of parts which are consumed, or used up, during normal Product operation include, but are not limited to, blades, reels, bedknives, tines, spark plugs, castor wheels, tires, filters, belts, etc.
- This warranty does not apply to failures caused by outside influence. Items considered to be outside influence include, but are not limited to, weather, storage practices, contamination, use of unapproved coolants, lubricants, additives, or chemicals, etc.
- This warranty does not apply to normal "wear and tear" items. Normal "Wear and Tear" includes, but is not limited to, damage to seats due to wear or abrasion, worn painted surfaces, scratched decals or windows, etc.

Other Legal Disclaimers:

The above remedy of product defects through repair by an authorized distributor or dealer is the purchaser's sole remedy for any defect. This warranty gives you specific legal rights, and you may also have other rights which vary from state to state.

Except for the Emissions warranty referenced below, if applicable, there is no other express warranty. All implied warranties of merchantability and fitness for use are limited to the duration of the express warranty.

Some states do not allow limitations on how long an implied warranty lasts, so the above limitation may not apply to you.

The Toro Company is not liable for indirect, incidental or consequential damages in connection with the use of the Product, including any cost or expense of providing substitute Product or service during periods of malfunction or non-use.

Some states do not allow the exclusion of incidental or consequential damages, so the above exclusion may not apply to you.