



Mid Size Traction Unit

15 H.P. Kohler Gear Drive

Model No. 30177—991352 and Up

Parts Catalog

Ordering Replacement Parts

To order replacement parts, please supply: the part number, the quantity, and the description of each part desired.

Understanding Reference Numbers

Each identified part in an illustration has a reference number. The reference number for a part also appears in the parts list, along with other information about the part.

This catalog uses two special reference number formats, one to indicate parts in a service assembly and another to indicate the quantity of a given part in an illustration.

Service Assembly Reference Numbers

Parts in service assemblies have reference numbers in the form **a:b**. The **a** represents the reference number of the entire service assembly and the **b** represents a sequential number unique to each part within the service assembly.

For example, a wheel assembly might be identified by reference number **6**, the tire by **6:1**, the valve by **6:2**, and the wheel by **6:3**. When you order the assembly identified by reference number **6**, you receive all parts identified by reference numbers **6:1**, **6:2**, and **6:3**. However, you may also order any part individually.

Reference numbers of this type appear in illustrations and in part lists.

Reference Numbers Indicating Quantity

In an illustration, if a reference number indicates more than one part, the reference number has the form **nX y**. The **n** represents the quantity of the part, the **X** is the multiplication symbol, and the **y** represents the reference number.

For example, in an illustration, the reference number **2X 37** means that two of the parts identified by reference number **37** are indicated.

Contents

Description	Page	Description	Page
Fuel Tank & Idler Bracket Assembly	1	Oil Pan / Lubrication	11
Transmission & Idler Pulley Assembly	2	Cylinder Head, Valves And Breather	12
Brake, Wheel Pulley & Wheel Assembly	3	Ignition / Electrical	13
Wheel And Tire Assembly	4	Blower Housing And Baffles	14
Handle & Control Panel Assembly	5	Starter System	15
Engine Assembly	6	Fuel System	16
Clutch Assembly No. 54-3200	7	Engine Controls	17
Engine Assembly	8	Air Cleaner	18
Clutch Assembly No. 54-3200	9	Exhaust	19
Crankcase	10		

Accessories

Description	Model / Part No.	Description	Model / Part No.
36" Cutting Unit	30135	Bag Kit For 37" Deck (Cloth Bag)	30129
44" Cutting Unit	30149	Bag Kit For 37" Deck (Steel Hopper)	30130
52" Cutting Unit	30151	Bag Kit For 44"and 52" Decks	30128
37" Recycler Deck	30137	Front Weight Kit For 36"/37" Deck	80-3350
44" Recycling Kit	59220	Steerable Sulky	30123
52" Recycling Kit	59225	Electric Start Kit	74-0980

Part Description Abbreviations

Part descriptions in this catalog may include the following abbreviations.

Abbreviation	Meaning	Abbreviation	Meaning
AR	as required	INC	incorporated
ASM	assembly	LH	left hand
CARR	carriage	NI	nylon insert
DEG	degrees	PPH	Phillips pan head
FH	flat head	PTH	Phillips truss head
GA	gauge	PTO	power take off
HF	hex flange	RH	right hand
HH	hex head	SFH	slotted fillister head
HHF	hex head flange	SHH	slotted hex head
HLH	hex lag head	SQH	square head
HJ	hex jam	SHWH	slotted hex washer head
HOC	height-of-cut	SPH	slotted pan head
HS	hex socket	SRH	slotted round head
HSBH	hex socket button head	STD	standard
HSFH	hex socket flat head	TAP	self tapping
HSH	hex socket head	TTH	Torx truss head
HWH	hex washer head	WH	wing head
HWHTF	hex washer head thread forming		

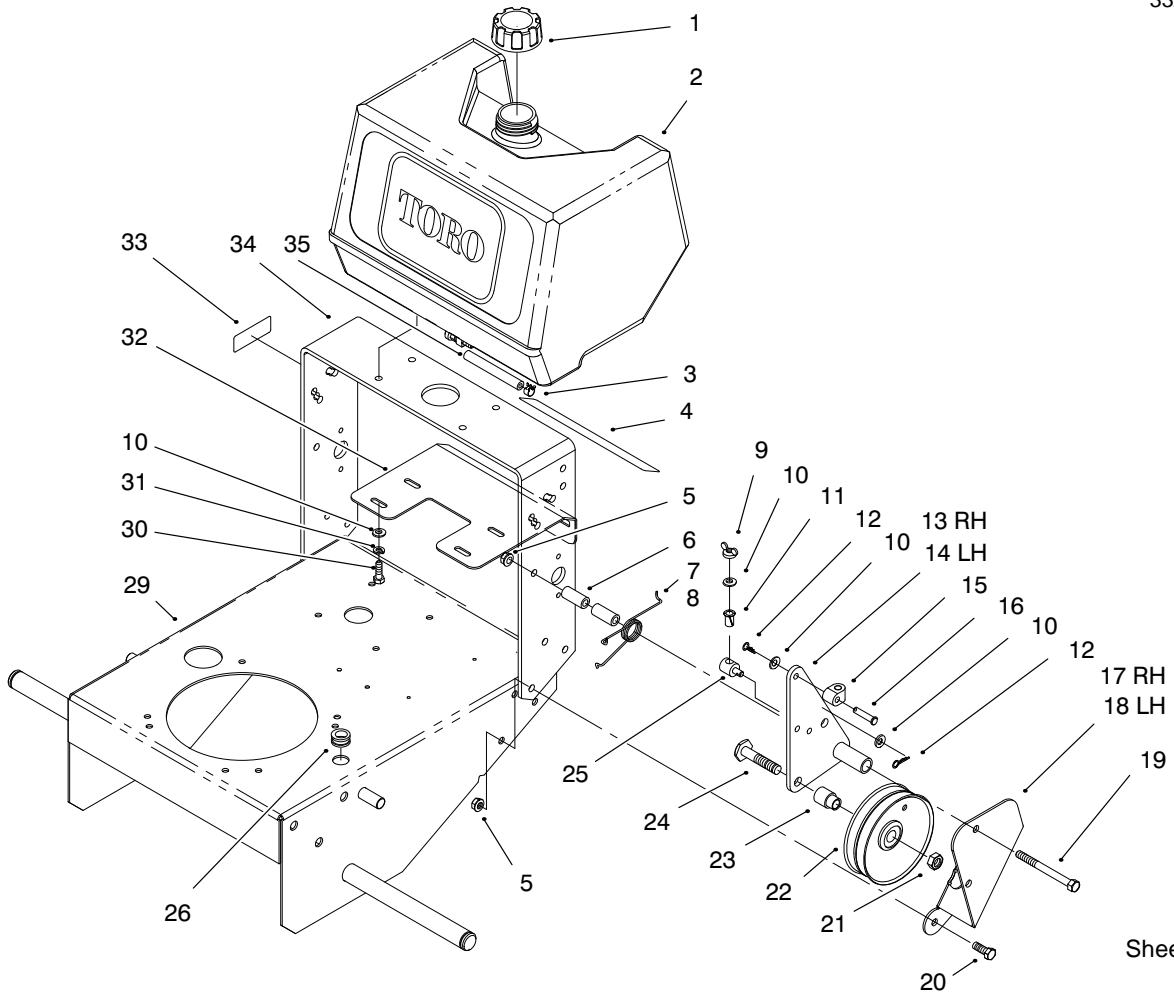

Sheet No.: 2

Fuel Tank & Idler Bracket Assembly

Ref. No.	Part No.	Qty.	Description
1	55-3570	1	Cap-Fuel
2	95-2802	1	Tank-Fuel
3	2412-98	2	Clamp-Hose
4	82-7750	1	Decal-Ground Speed
5	3296-39	8	Nut-Lock
6	74-0040	4	Spacer-Pivot
7	51-4370	1	Spring-RH
8	51-4380	1	Spring-LH
9	32103-25	2	Nut-Wing
10	3256-23	10	Washer-Flat
11	52-2890	2	Bushing-Flanged
12	3290-307	4	Pin-Cotter
13	74-0230-01	1	Idler Bracket RH
14	74-0220-01	1	Idler Bracket LH
15	74-0521	2	Rod-Fitting
16	283-6	2	Pin-Clevis
17	67-6370-01	1	Bracket-RH
18	67-6380-01	1	Bracket-LH
19	323-16	2	Screw-HH
20	323-6	6	Screw-HH
21	3296-23	2	Nut-Lock
22	95-2800	2	Pulley-Idler
23	95-2801	2	Spacer-Pulley
24	51-4450	2	Screw-Leveler
25	68-9690	2	Fitting Rod
26	237-124	1	Grommet

Ref. No.	Part No.	Qty.	Description
29	93-1156-01	1	Frame
30	322-4	4	Screw-HH
31	3253-4	4	Washer-Lock
32	66-7400-01	1	Plate-Control
33	95-2814	1	Decal-Fuel Shut-Off
34	74-0360-01	1	Frame-Rear
35	47-2964	1	Hose-Gas

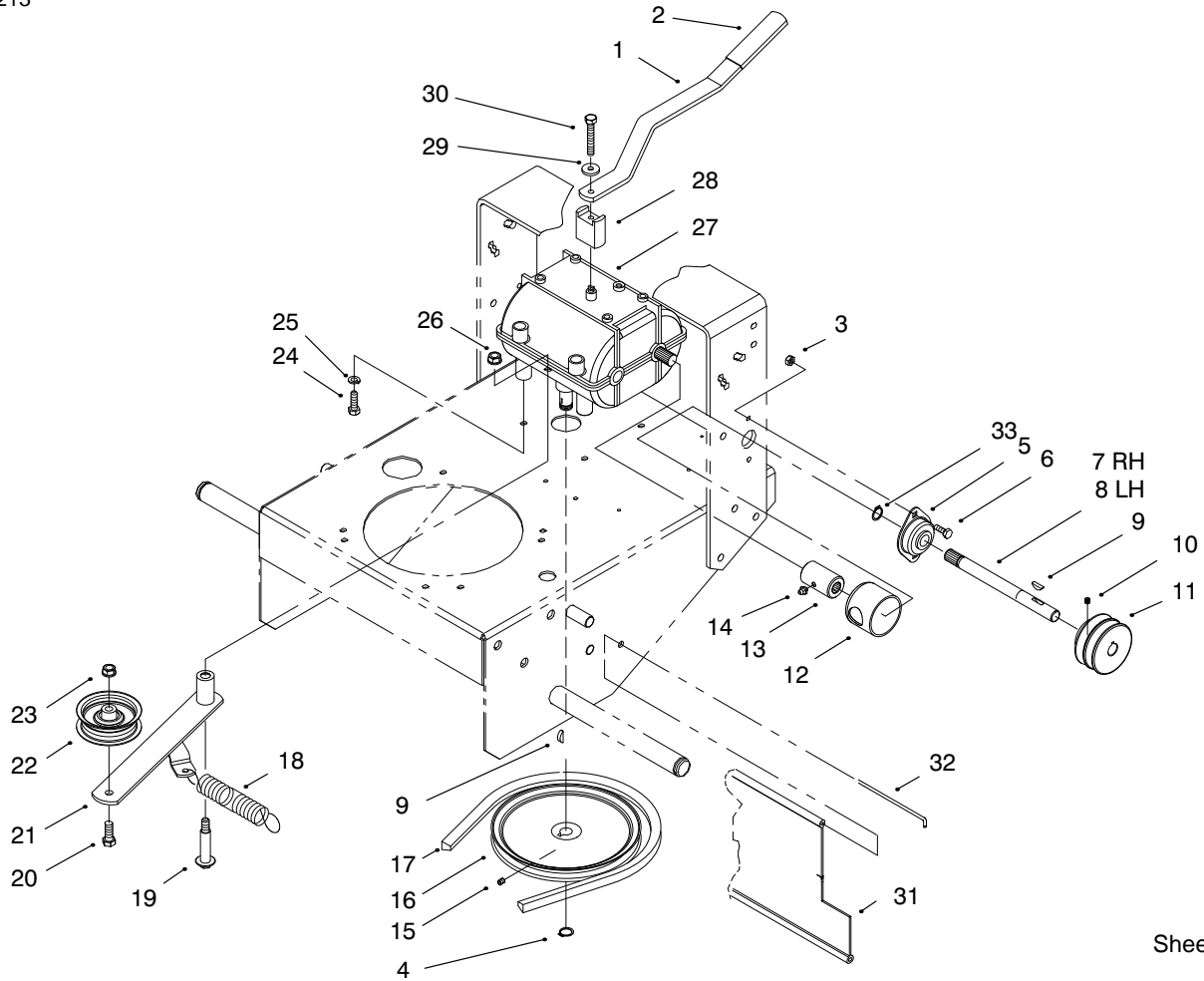

Sheet No.: 3

Transmission & Idler Pulley Assembly

Ref. No.	Part No.	Qty.	Description
1	74-0320-01	1	Lever-Shift
2	47-1970	1	Grip-Engagement
3	3296-42	4	Nut-Lock
4	32120-64	1	Ring-Retaining
5	51-4270	2	Bearing-Shaft Ext
6	321-4	4	Screw-HH
7	98-0788	1	Shaft-RH
8	98-0787	1	Shaft-LH
9	3257-5	3	Key-Woodruff
10	3245-3	2	Screw-HSH
11	74-0480	2	Pulley-Drive ASM
12	51-4220	2	Guard-Coupler
13	98-0789	2	Coupler
14	302-5	2	Fitting-Grease
15	3245-1	1	Screw-Set
16	51-4190	1	Pulley-Drive
17	26-9671	1	"v" Belt
18	68-2190	1	Spring-Extension
19	27-6230	1	Bolt-Wheel
20	323-8	1	Screw-HH
21	16-7509	1	Lever-Idler
22	62-4540	1	Pulley-Idler
23	3296-39	1	Nut-Lock
24	322-2	4	Screw-HH
25	3253-4	4	Washer-Lock
26	3296-6	1	Nut-Lock

Ref. No.	Part No.	Qty.	Description
†27	98-0791	1	Transmission-Peerless (Model 700-082)
28	72-2190	1	Mount-Shift Lever
29	7-5461	1	Spacer-Transmission
30	329-10	1	Screw
31	95-1526	1	Shield-Trailing
32	95-1529	1	Rod-Shield
33	32151-62	2	Ring-Retaining

† Obtain locally from Peerless

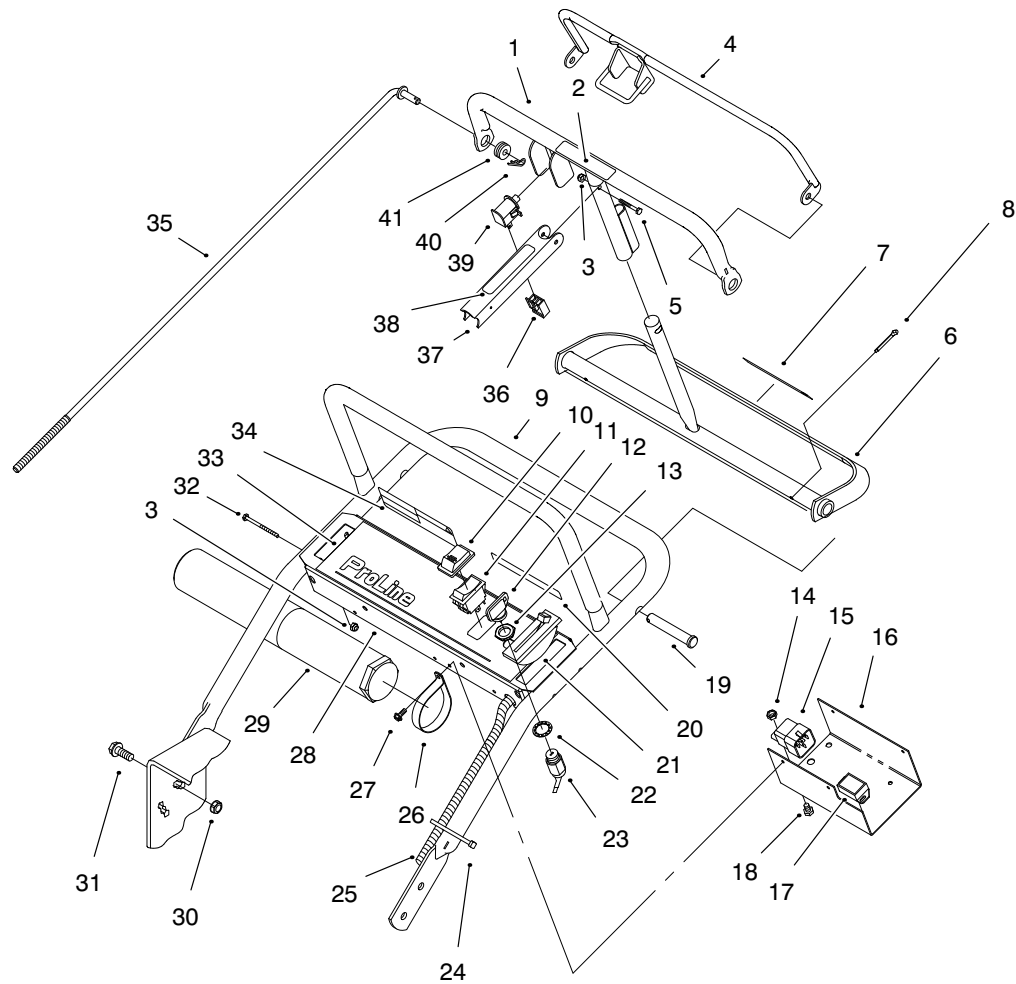

Sheet No.: 5

Handle & Control Panel Assembly

Ref. No.	Part No.	Qty.	Description	Ref. No.	Part No.	Qty.	Description
1	82-7690-03	1	Bar	27	32104-76	4	Screw-Self TAP
2	82-2290	1	Decal-Control Bar	28	82-2180-03	1	Panel-Control
3	3296-2	5	Nut-Lock	29	74-0720	1	Tube-Manual
4	82-7680-03	1	Bail	30	32128-21	4	Nut-HF
5	32105-1	1	Screw-HH	31	3234-11	4	Screw-HHF
6	99-8501-03	1	Control Pivot	32	32105-14	4	Screw-HH
7	82-2280	1	Decal-Reverse	33	82-7730	1	Decal-Panel Proline
8	3272-11	2	Pin-Cotter	34	71-1280	1	Decal-Warning
9	67-6440-01	1	Handle-Upper	35	82-7631	2	Rod-Control
10	82-3820-01	1	Boot-Switch	36	218-595	1	Connector-Body
11	82-2300	1	Switch	37	51-4850-03	1	Lever-Parking Brake
12	63-8360	2	Key-Ignition	38	52-2010	1	Decal-Parking Lever
13	218-461	1	Nut-HH (F/W Sw)	39	82-2190	1	Switch-Bail
14	3296-42	1	Nut-Lock	40	3290-307	2	Pin-Cotter
15	63-7590	1	Relay	41	237-141	2	Grommet
16	93-1187-03	1	Panel-Bottom				
17	94-9666	1	Module				
18	321-2	1	Screw-HH				
19	283-55	2	Pin-Clevis				
20	65-3090	1	Decal-Manual				
21	74-0630	1	Control-Throttle				
22	3254-5	1	Washer-Lock				
23	29-5560	1	Switch-On/Off				
24	3290-378	2	Tie-Cable				
25	95-2803	1	Wire Harness				
26	2412-120	2	Clamp-R				

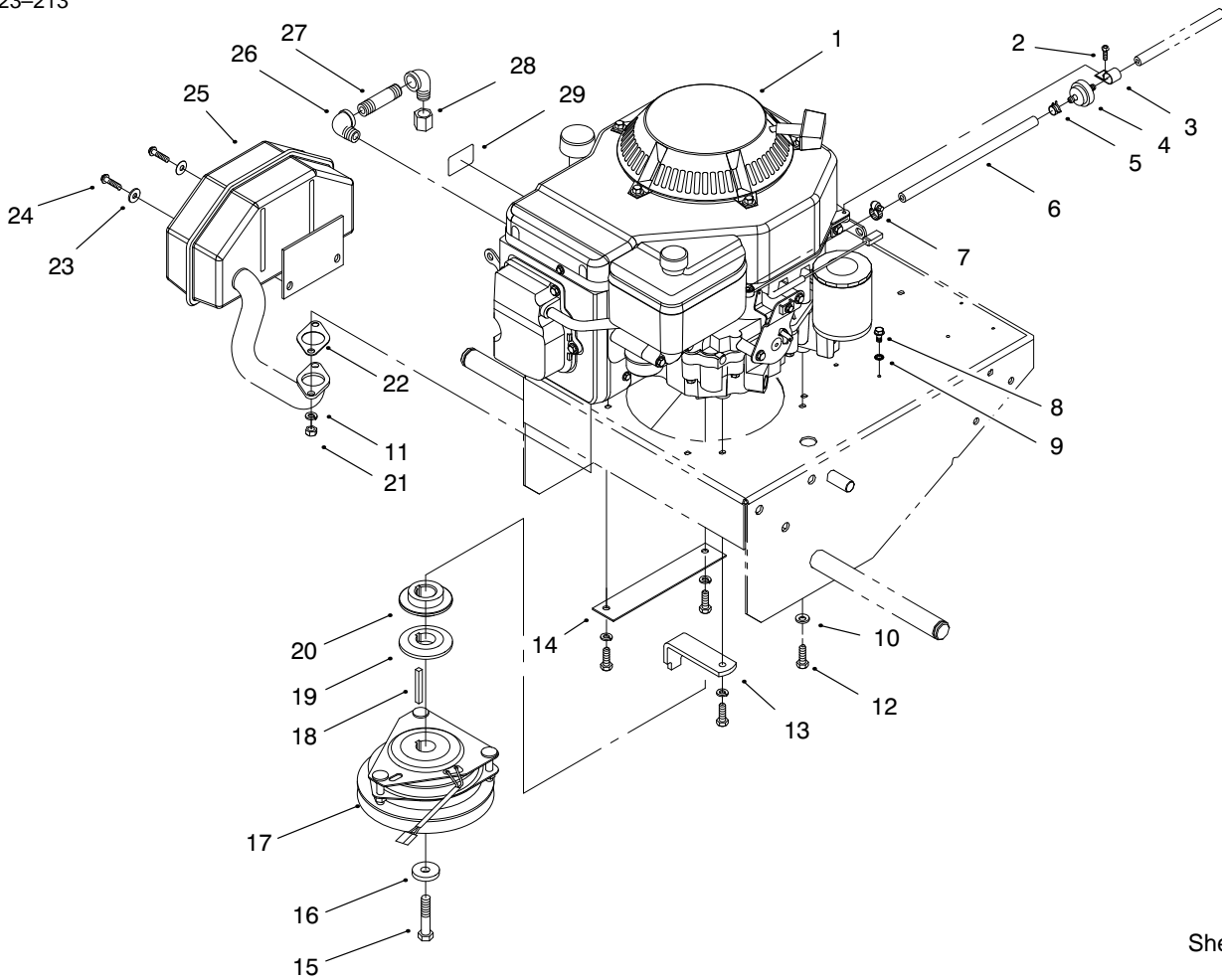

Sheet No.: 6

Engine Assembly

Ref. No.	Part No.	Qty.	Description
1		1	Engine-15 Hp Kohler
2	32144-19	1	Screw-HH
3	2412-87	1	Clamp-Cable
4	56-6360	1	Filter-Fuel
5	2412-98	1	Clamp-Hose
6	47-2982	1	Hose-Fuel
7	2412-108	1	Clamp-Hose
8	12-3270	1	Screw-HH
9	3255-7	1	Washer-Lk
10	3256-23	1	Washer-Flat
11	3253-4	2	Washer-Lock
12	33114-025	4	Screw-HH
13	51-4540-03	1	Retainer-Clutch
14	74-0930-01	1	Guard-Pulley
15	3212-9	1	Screw-HH
16	112843	1	Washer-PTO
17	54-3200	1	Clutch/Brake
18	608006	1	Key
19	74-0050	1	Sheave-Lower
20	74-0060	1	Sheave-Upper
21	93-7034	2	Nut-Muffler
22	93-7032	1	Gasket-Exhaust
23	3256-78	2	Washer-Plain
24	93-7033	2	Screw
25	95-5517	1	Muffler
26	74-0950	2	Elbow

Ref. No.	Part No.	Qty.	Description
27	289-20	1	Nipple-Pipe
28	288-4	1	Cap-Pipe
29	63-8440	1	Decal-Hot Surface

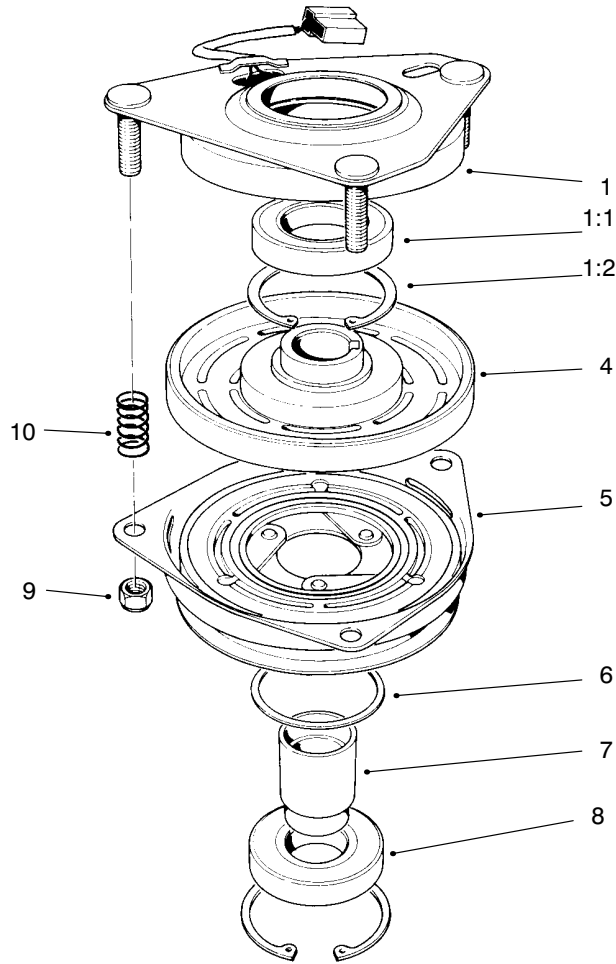

Sheet No.: 301

Clutch Assembly No. 54-3200

Ref. No.	Part No.	Qty.	Description
1	54-0230	1	Field ASM
1:1	251-292	1	Bearing
1:2	44-8310	2	Ring-Retaining
4	44-8360	1	Field Coil & Bearing
5	44-8370	1	Armature & Pulley ASM
6	44-8330	1	Spacer-Pulley Bearing
7	44-8340	1	Collar-Bearing
8	251-291	1	Bearing-Pulley
9	3296-6	3	Nut-Lock
10	44-8320	3	Spring

Ref. No.	Part No.	Qty.	Description

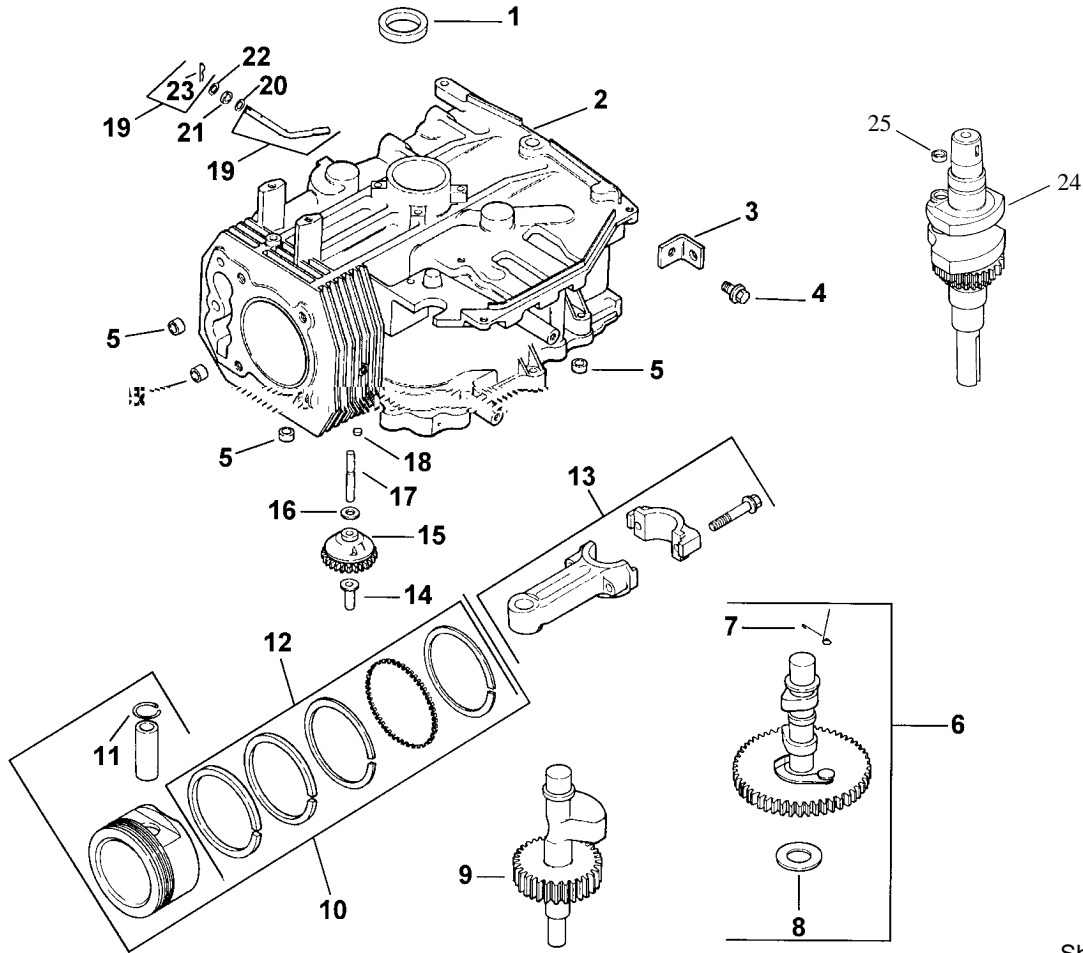

Sheet No.: 2 01

Crankcase

Ref. No.	Part No.	Qty.	Description
1	12 032 03	1	Seal-Crankshaft
2	12 522 18	1	Shortblock
3	12 445 02	1	Strap-Lifting
4	M-0839025	1	Screw M8x1.25x22
5	12 380 17	4	Dowel-Locating
6	12 755 49	1	Kit-Camshaft INC 7-8
7	12 089 31	1	Spring-Actuating
8	12 422 07	A/R	Shim-Camshaft A/R
8	12 422 08	1	Shim-Camshaft A/R
8	12 422 09	A/R	Shim-Camshaft A/R
8	12 422 10	A/R	Shim-Camshaft A/R
8	12 422 11	A/R	Shim-Camshaft A/R
8	12 422 12	A/R	Shim-Camshaft A/R
8	12 422 13	A/R	Shim-Camshaft A/R
9	12 144 27	1	Shaft-Balance
10	12 847 07	1	Set Piston w/Ring STD
10	12 847 08	1	Set-Piston w/Ring .25
10	12 847 09	1	Set-Piston w/Ring .50
11	12 018 02	2	Retainer-Piston Pin
12	12 108 07	1	Ring Set STD
12	12 108 08	1	Ring Set .25
12	12 108 09	1	Ring Set .50
13	12 067 05	1	Rod Connecting STD
13	12 067 06	1	Rod Connecting .25

Ref. No.	Part No.	Qty.	Description
14	12 380 01	1	Pin-Governor Regulating
15	12 043 05	1	Gear-Governor ASM
16	M-0631005	1	Washer-Governor
17	12 144 02	1	Shaft-Governor Gear
18	52 139 09	1	Plug-Cup
19	12 755 64	1	Kit - Shaft-Governor Cross (Incl. Ref.#23)
20	X-25-102	1	Washer-Flat
21	12 032 01	1	Seal-Governor Shaft
22	M-0631015	1	Washer-Governor Shaft
23	12 154 05	1	Clip - Hitch Pin
24	12 014 30	1	Crankshaft ASM
25	12 139 01	1	Plug-Cup
*	12 030 02	1	Bearing - Crankshaft 0.25
*	12 030 03	1	Bearing - Crankshaft 0.50
*	12 755 82	1	Set - Gasket

* Not illustrated
 ENGINE KOHLER MODEL NO. CV15T Spec 41560
 Obtain Parts From Kohler

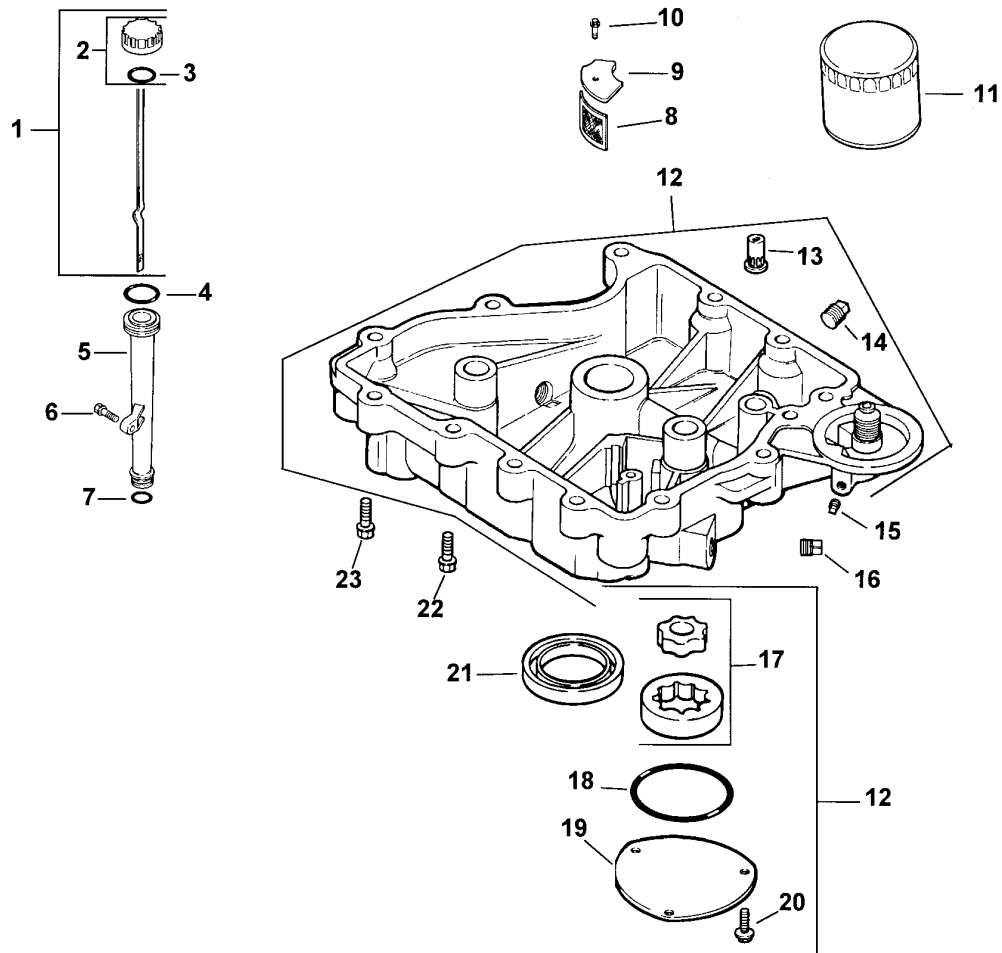

Sheet No.: 2 02

Oil Pan / Lubrication

Ref. No.	Part No.	Qty.	Description
1	12 038 01	1	Dipstick INC 2-3
2	25 755 13	1	Kit-Oil Cap INC 3
3	12 153 03	1	O Ring-Fill Cap
4	12 153 02	1	O Ring-Upper Fill Tube
5	12 123 04	1	Tube-Oil Fill
6	M-0545020	1	Screw M5x0.8x20
7	12 153 01	2	O Ring-Lower Fill Tube
8	25 162 07	1	Screen-Oil
9	12 096 03	1	Cover-Oil Pickup Screen
10	M-0545016	1	Screw M5x0.8x16
11	52 050 02	1	Filter-Oil
12	12 199 45	1	Pan - Oil (Incl. Ref. #13, 14, 17-20)
13	25 462 09	1	Valve - Oil Pressure
14	X-75-2	2	Plug-1/4nptf
15	X-75-1	2	Plug-1/8nptf
16	X-75-10	2	Plug-SH 3/8 NPTF
17	12 393 01	1	Pump-Oil
18	12 153 06	1	O Ring-Oil Pump Cover
19	12 096 34	1	Cover-Oil Pump
20	M-0545016	3	Screw M5x0.8x16
21	12 032 03	1	Seal-Crankshaft

Ref. No.	Part No.	Qty.	Description
22	24 086 16	11	Screw-M8X1.25X45
23	24 068 17	1	Screw-M5X1.25X45

ENGINE KOHLER MODEL NO. CV15T Spec 41560
Obtain Parts From Kohler

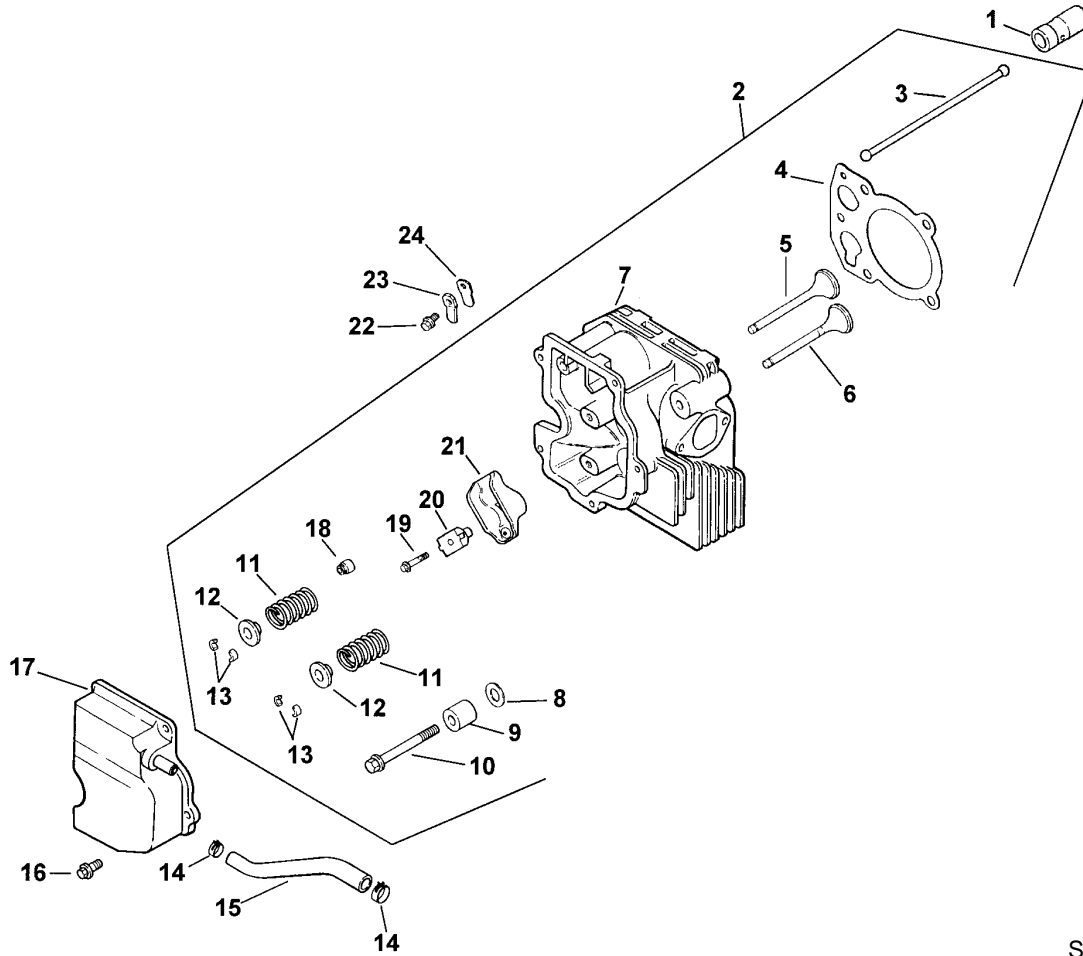

Sheet No.: 2 03

Cylinder Head, Valves And Breather

Ref. No.	Part No.	Qty.	Description
1	12 351 02	2	Lifter-Valve
2	12 755 81	1	Kit-Cylinder Head
3	12 411 01	2	Rod-Push
4	12 041 10	1	Gasket-Cylinder Head
5	12 017 01	1	Valve-Intake STD
5	12 017 02	1	Valve-Intake .25
6	12 016 01	1	Valve-Exhaust STD
6	12 016 02	1	Valve-Exhaust .25
7	12 318 19	1	Head - Cylinder
8	12 468 05	1	Washer-Flat
9	12 112 13	1	Spacer-Head Bolt Exhaust
10	12 086 15	5	Screw M10x1.5x80
11	12 089 01	1	Spring-Valve
12	12 173 01	2	Cap-Valve Spring
13	12 755 03	2	Kit-Retainer
14	X-426-9	2	Clamp-Hose
15	12 326 03	1	Hose-Breather
16	M-0645020	3	Screw-HH M6x1.0x20
17	12 096 07	1	Cover-Valve w/Nipple
18	24 023 05	1	Seal-Valve Spring
19	M-0640034	2	Screw M6x1.0x34
20	12 599 03	2	Pivot - Rocker Arm
21	25 186 01	2	Arm-Rocker
22	M-0545010	1	Screw M5x0.8x10

Ref. No.	Part No.	Qty.	Description
23	12 018 01	1	Retainer-Breather Reed
24	12 402 02	1	Reed-Breather

ENGINE KOHLER MODEL NO. CV15T Spec 41560
Obtain Parts From Kohler

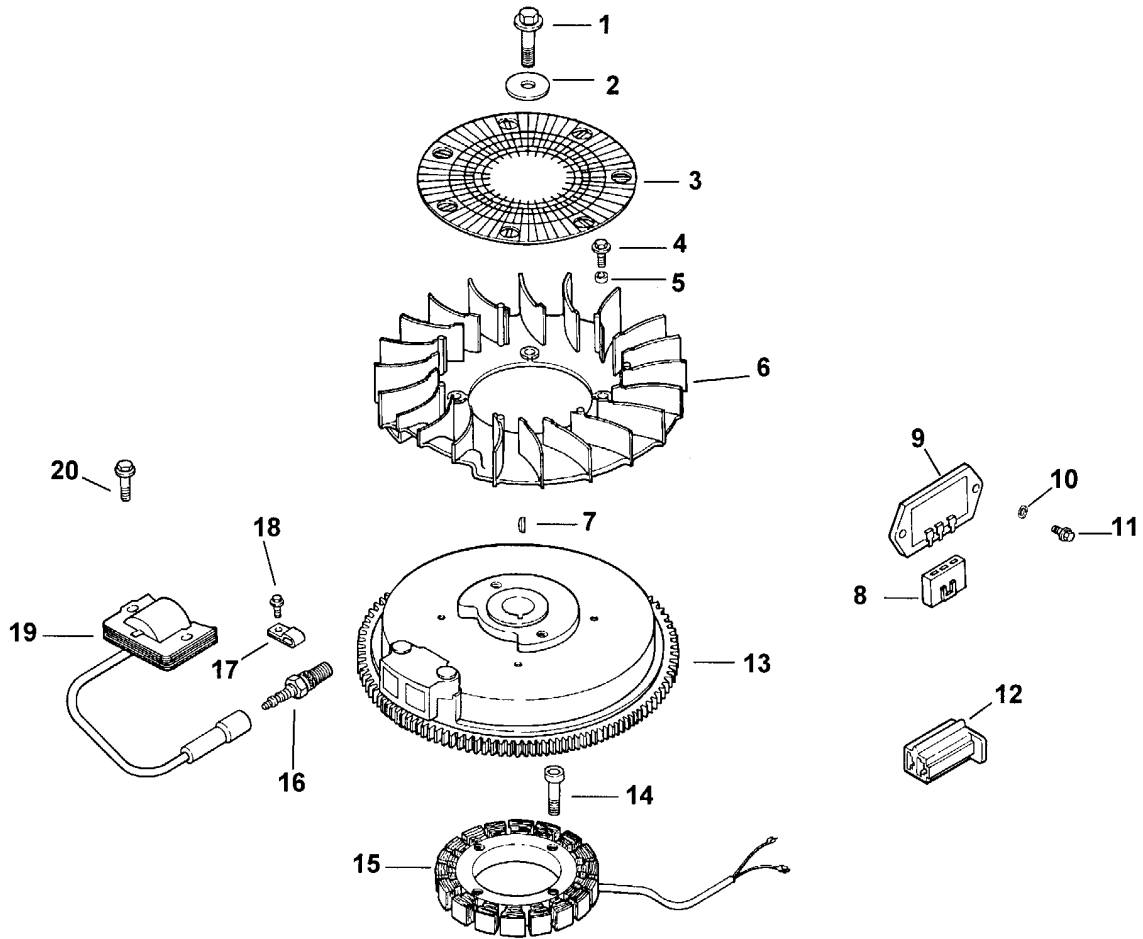

Sheet No.: 2 04

Ignition / Electrical

Ref. No.	Part No.	Qty.	Description
1	12 086 14	1	Screw-Flywheel Mounting
2	12 486 03	1	Washer-Flat
3	12 162 03	1	Screen-Grass
4	M-0639016	4	Screw M6x1.0x16
5	12 112 01	4	Spacer-Fan
6	12 157 02	1	Fan
7	X-42-15	1	Key
8	236602	1	Connector-Regulator
9	12 403 01	1	Rectifier-Unregulated
10	X-22-11	2	Washer - Lock
11	M-0639016	2	Screw M6x1.0x16
12	41 155 03	1	Connector
13	12 025 33	1	Flywheel ASM
14	M-0548025	4	Screw M5x0.8x25
15	54 755 09	1	Kit - Stator-15 Amp (Incl.Bracket P/N #24 126 71)
16	12 132 02	1	Spark Plug
17	X-728-1	2	Clip-Kill Lead
18	M-0545010	1	Screw M5x0.8x10
19	12 584 02	1	Module-Ignition
20	M-0545020	2	Screw M5x0.8x20
*	X-25-5	1	Washer
	12 518 01	1	Lead-White
*	25 518 05	1	Lead-Black

Ref. No.	Part No.	Qty.	Description
*	25 518 29	1	Lead-Black
*	24 126 71	1	Bracket - Stator Wire

* Not illustrated
 ENGINE KOHLER MODEL NO. CV15T Spec 41560
 Obtain Parts From Kohler

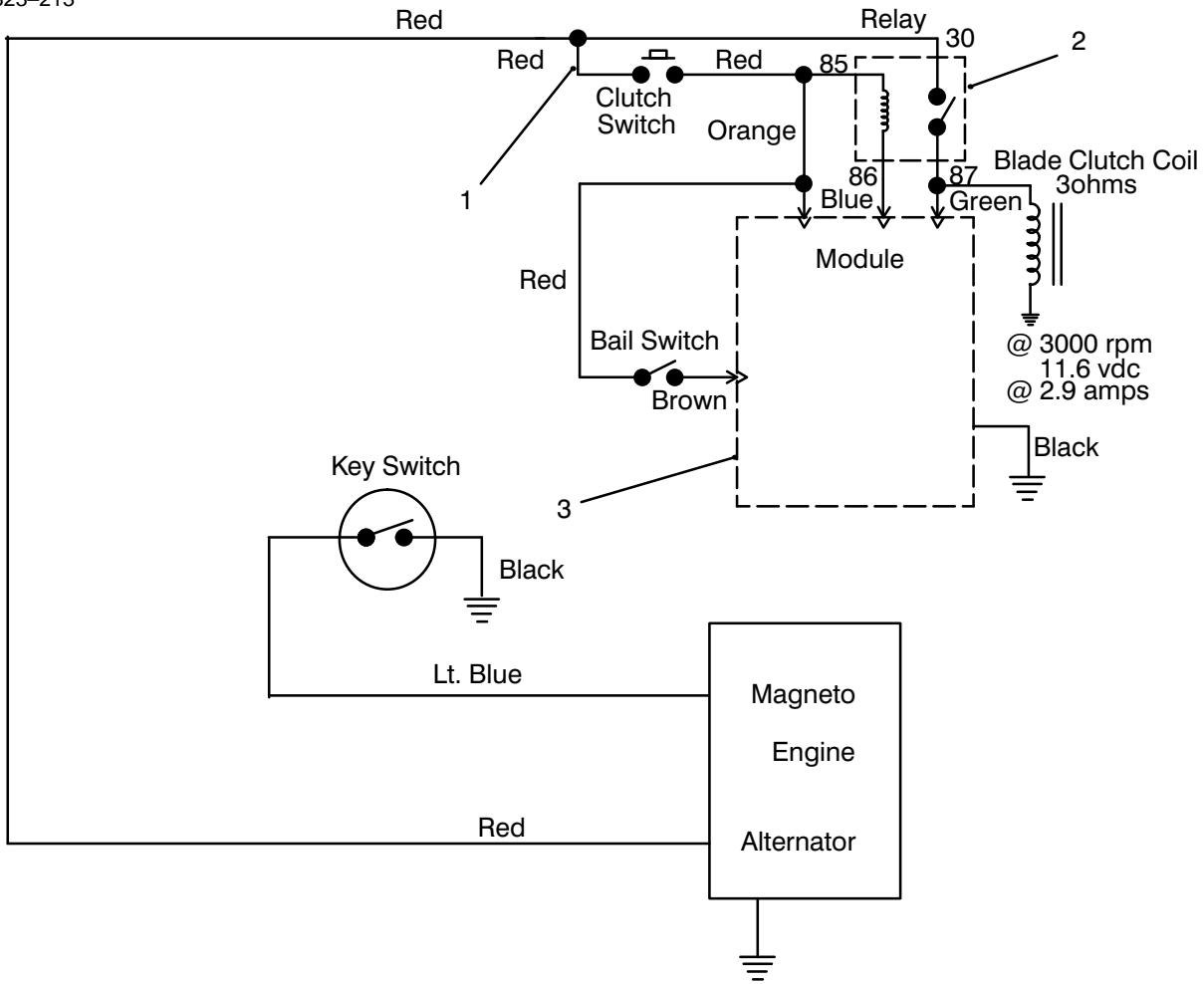

Electric Schematic

Ref. No.	Part No.	Qty.	Description
1	95-2803	1	Wire Harness
2	63-7590	1	Relay
3	94-9666	1	Module - Interlock

Ref. No.	Part No.	Qty.	Description

