



Count on it.

Parts Catalog

**CCR™ 6053 R Quick Clear
Snowthrower**

Model No. 38563—Serial No. 405012000 and Up



Ordering Replacement Parts

To order replacement parts, please supply the part number, the quantity, and the description of each part desired.

Understanding Reference Numbers

Each identified part in an illustration has a reference number. The reference number for a part also appears in the parts list, along with other information about the part.

This catalog uses two special reference number formats, one to indicate parts in a service assembly and another to indicate the quantity of a given part in an illustration.

Service Assembly Reference Numbers

Parts in service assemblies have reference numbers in the form a:b. The a represents the reference number of the entire service assembly and the b represents a sequential number unique to each part within the service assembly.

For example, a wheel assembly might be identified by reference number 6, the tire by 6:1, the valve by 6:2, and the wheel by 6:3. When you order the assembly identified by reference number 6, you receive all parts identified by reference numbers 6:1, 6:2, and 6:3. However, you may also order any part individually. Reference numbers of this type appear in illustration and in parts lists.

Reference Numbers Indicating Quantity

In an illustration, if a reference number indicates more than one part, the reference number has the form nX y. The n represents the quantity of the part, the X is the multiplication symbol, and the y represents the reference number.

For example, in an illustration, the reference number 2X 37 means that two of the parts identified by reference number 37 are indicated.

Contents

Main Frame, Lower Chute and Wheel Assembly	4
Rotor Drive Assembly	6
Rotor Assembly	8
Engine Assembly	10
Engine Assembly No. 1.....	12
Engine Assembly No. 2.....	14
Engine Assembly No. 3.....	16
Shroud Assembly	18
Chute Control Assembly	20
Handle Assembly	22
Slider Track Assembly.....	24
Attachments and Accessories	26

Main Frame, Lower Chute and Wheel Assembly

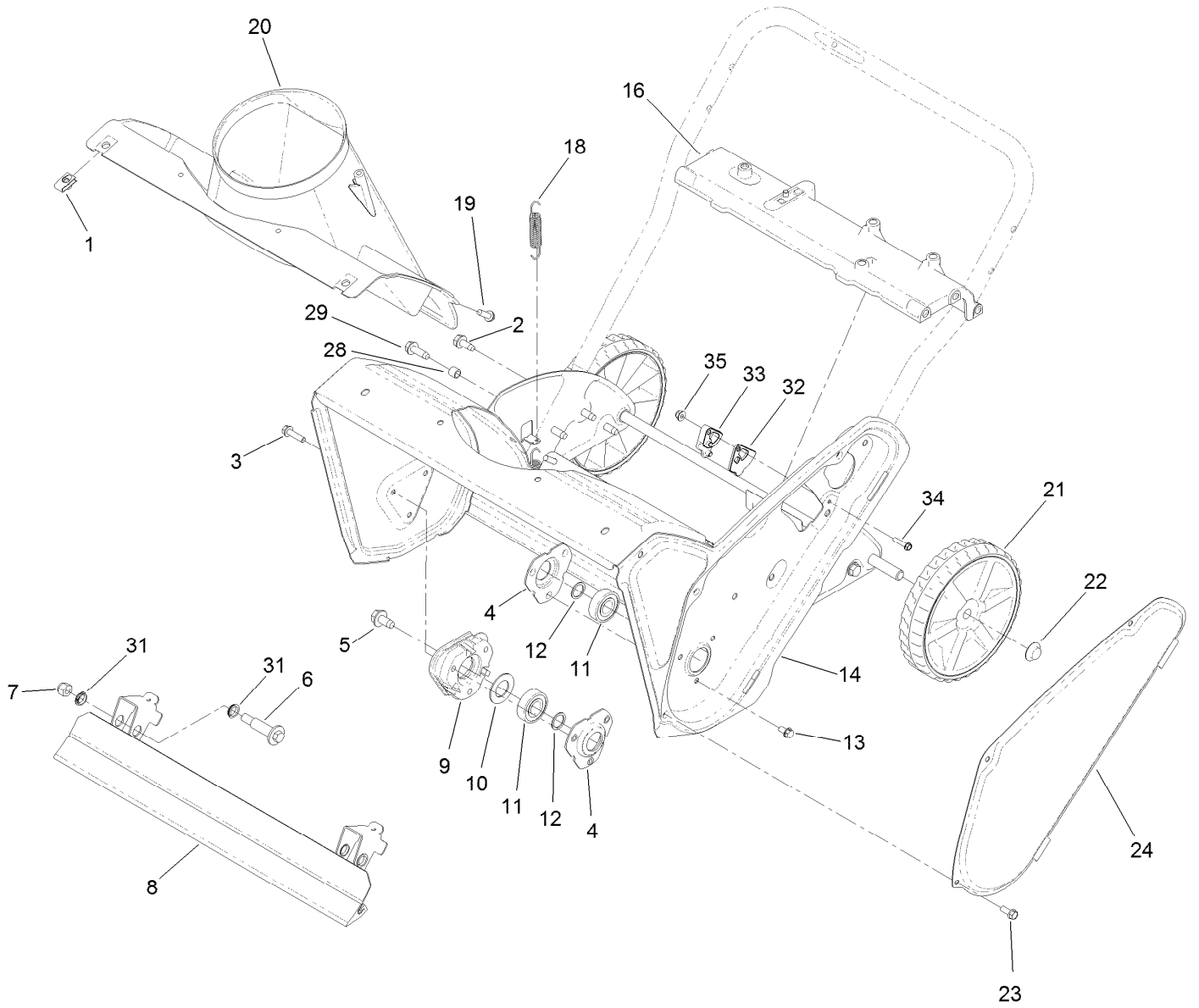

Main Frame, Lower Chute and Wheel Assembly (continued)

<i>Ref.</i>	<i>Part Number</i>	<i>Qty.</i>	<i>Description</i>	<i>Ref.</i>	<i>Part Number</i>	<i>Qty.</i>	<i>Description</i>
1	107069	2	Clip	18	108-4906	2	Spring-Extension
2	137-3044	4	Screw-Thd Roll, HWH	19	137-3099	3	Screw-Plastite, HWH
3	32144-86	3	Screw-HWHTF	20	108-4871	1	Chute-Lower
4	136-7134	2	Flange-Bearing	21	117-2309	2	Wheel ASM
5	110-9380	1	Screw-HWH	22	32112-14	2	Nut-Push
6	136-7198	2	Bolt-Shoulder	23	32144-85	3	Screw-HWH
7	137-3087	2	Nut-Hex	24	108-4893-03	1	Cover-Belt
8	139-3536	1	Scraper ASM	28	136-7148	2	Spacer-Grommet
9	114-3781	1	Spacer-Bearing, RH	29	136-7174	2	Screw-Thd Roll, HWH
10	110-9353	1	Washer-Rubber	31	139-3509	2	Bushing-Nyliner
11	38-7820	2	Bearing-Ball	32	139-3564	1	Cap-Guide, Cable
12	52-7280	2	Washer-Thrust	33	139-3565	1	Guide-Cable
13	32144-4	3	Screw-HWH	34	106-9169	1	Screw-HWH
14	108-4868-03	1	Housing-Auger	35	138-0719	1	Nut-HF
16	130-9765	1	Brace-Frame				

Rotor Drive Assembly

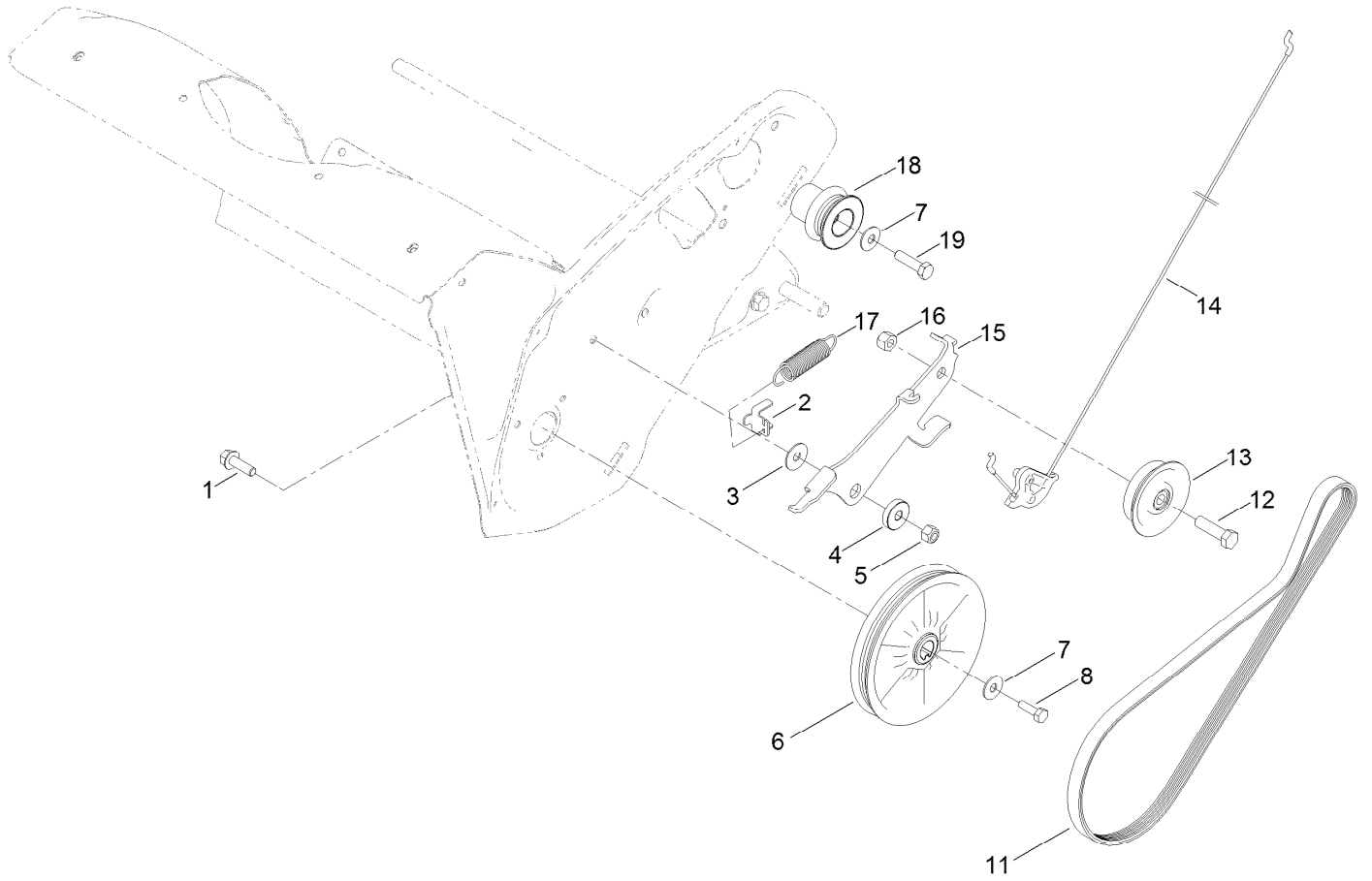

Rotor Drive Assembly (continued)

<i>Ref.</i>	<i>Part Number</i>	<i>Qty.</i>	<i>Description</i>	<i>Ref.</i>	<i>Part Number</i>	<i>Qty.</i>	<i>Description</i>
1	137-3067	1	Screw-HHF	12	137-3065	1	Screw-HH
2	136-7133	1	Clip-Spring	13	114-3785	1	Pulley-Idler
3	108-4925	1	Washer	14	140-1000	1	Cable-Clutch
4	108-4916	1	Bushing-Pivot	15	136-7138	1	Arm-Idler
5	119-4038	1	Nut-Hex	16	137-3047	1	Nut-Hex
6	121-6624	1	Pulley	17	121-6630	1	Spring-Extension
7	3290-456	2	Washer-Belleville	18	125-7927	1	Pulley-Engine
8	137-3003	1	Screw-HH,Lock	19	137-3021	1	Screw-HH Lock
11	121-6622	1	Belt-Drive				

Rotor Assembly

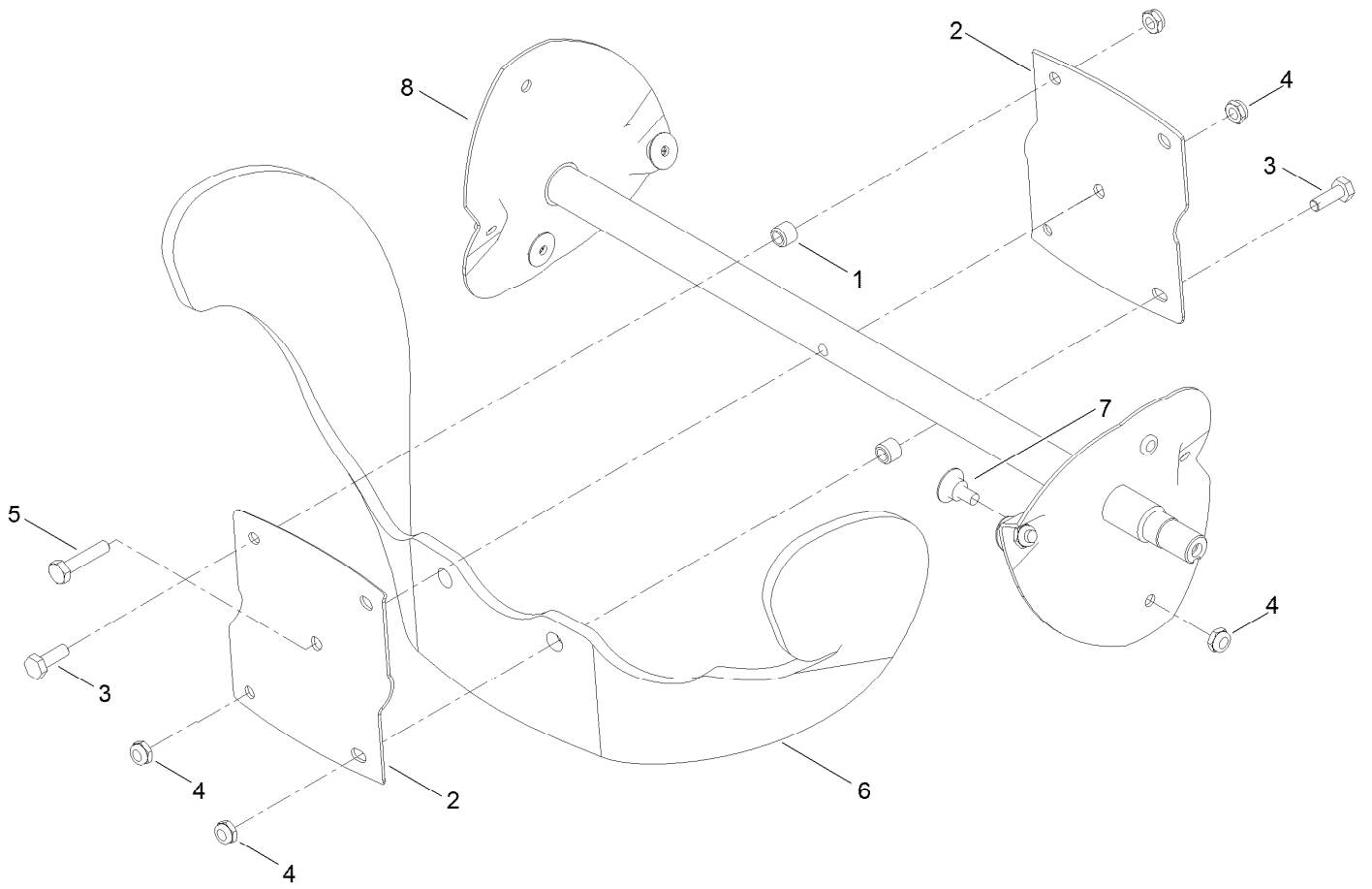

Rotor Assembly (continued)

<i>Ref.</i>	<i>Part Number</i>	<i>Qty.</i>	<i>Description</i>	<i>Ref.</i>	<i>Part Number</i>	<i>Qty.</i>	<i>Description</i>
1	55-9370	4	Spacer-Blade, Rotor	5	137-3049	1	Screw-HH
2	66-6600-03	2	Half-Rotor	6	99-9313	2	Blade-Rotor
3	137-3042	4	Screw-HH	7	136-7182	8	Screw-Countersunk, Oval
4	137-3091	13	Nut-Hex	8	131-6490	1	Rotor Kit

Engine Assembly

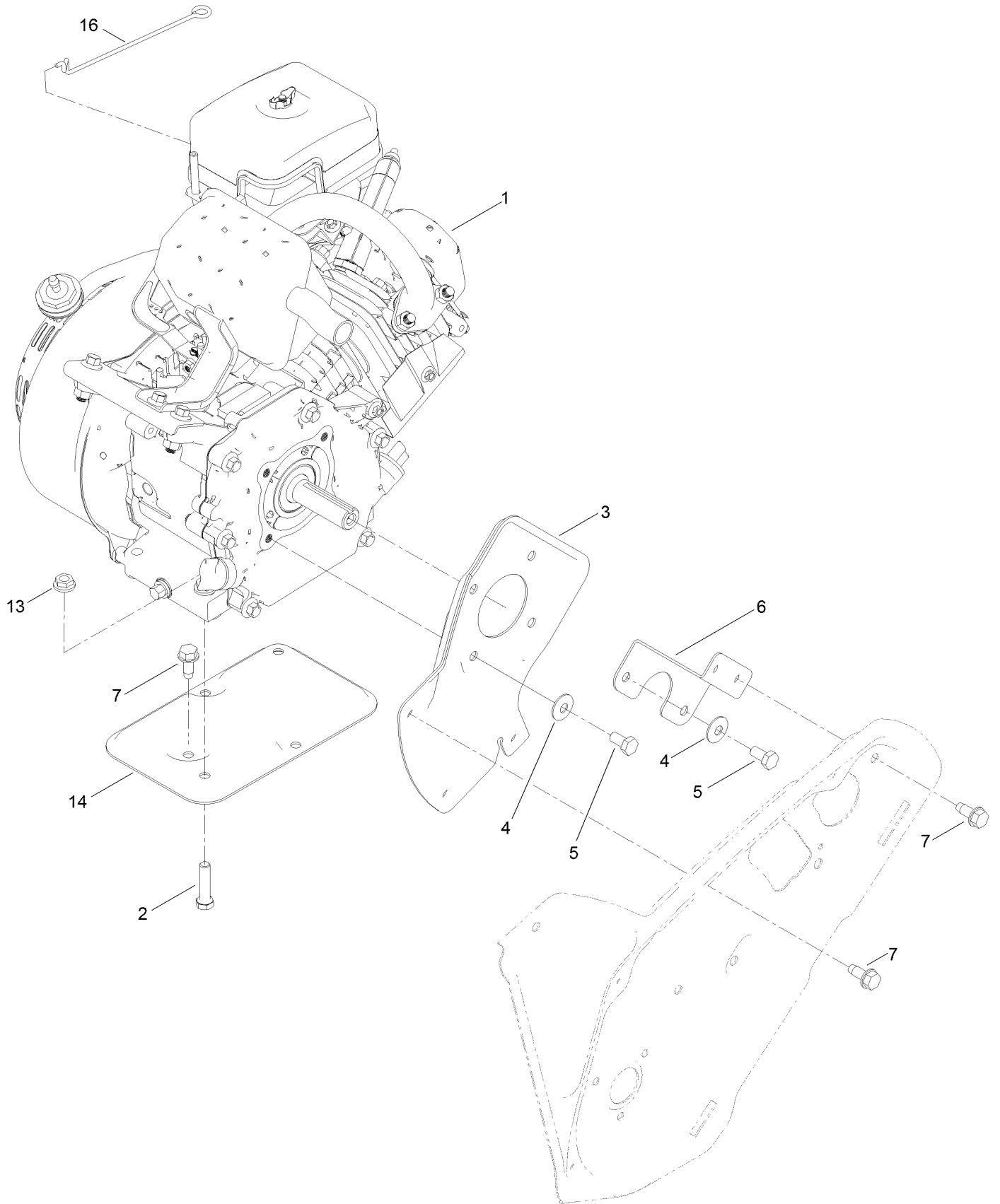

Engine Assembly (continued)

<i>Ref.</i>	<i>Part Number</i>	<i>Qty.</i>	<i>Description</i>	<i>Ref.</i>	<i>Part Number</i>	<i>Qty.</i>	<i>Description</i>
1	121-4224	1	Engine-170Fs-2	6	110-9354-03	1	Support-Engine, Side
2	137-3051	2	Screw-HH	7	137-3044	7	Screw-Thd Roll, HWH
3	108-4892-03	1	Plate-Engine, PTO	13	137-3039	2	Nut-HF
4	3290-456	4	Washer-Belleville	14	117-6037-03	1	Support-Engine
5	137-3097	4	Screw-HH	16	136-7140	1	Link-Choke

Engine Assembly No. 1

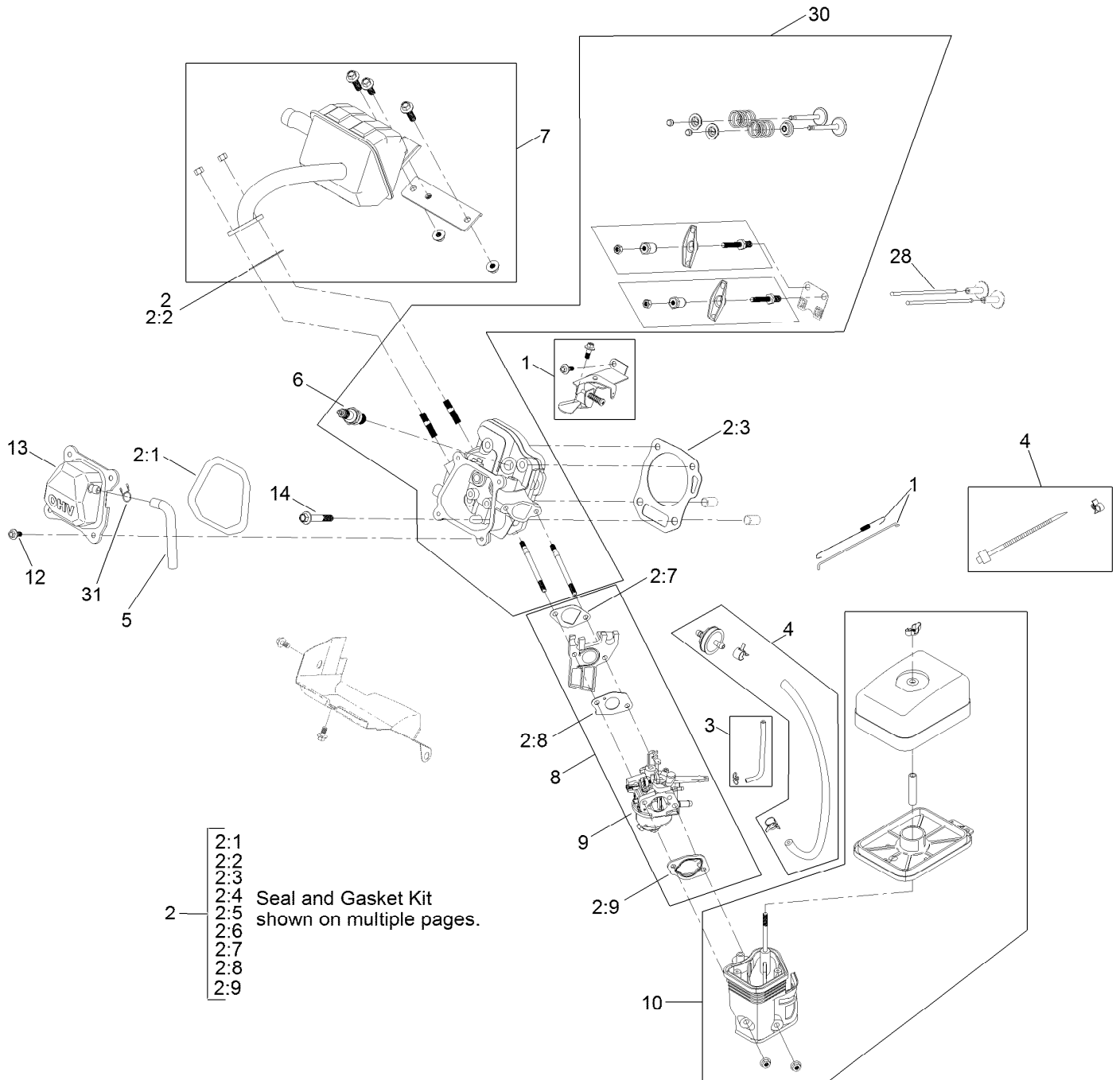

Engine Assembly No. 1 (continued)

<i>Ref.</i>	<i>Part Number</i>	<i>Qty.</i>	<i>Description</i>	<i>Ref.</i>	<i>Part Number</i>	<i>Qty.</i>	<i>Description</i>
1	136-7765	1	Governor Kit	6	119-1901	1	Plug-Spark
2	127-9001	1	Gasket And Seal Kit	7	121-4297	1	Muffler Kit
2:1	121-0109	1	Gasket-Cover, Valve	8	127-9008	1	Carburetor Kit
2:2	121-0167	1	Gasket-Exhaust	9	127-9089	1	Carb Repair Kit With Gaskets
2:3	127-9000	1	Gasket-Head, Cylinder	10	121-4282	1	Heater Box Kit
2:4	121-0208	1	Seal-Oil	12	120-4454	4	Screw-HHF
2:5	121-0209	1	Seal-Oil	13	121-0499	1	Valve Cover ASM
2:6	121-0105	1	Gasket-Cover, Crankcase	14	121-4110	4	Screw-HHF
2:7	121-0076	1	Gasket-Carburetor	28	121-4121	2	Rod-Push
2:8	121-0078	1	Gasket-Carburetor	30	133-9839	1	Complete Head ASM
2:9	121-0080	1	Gasket-Carburetor	31	127-9408	1	Clamp-Hose
3	127-9376	1	Primer Line Kit	99	127-9037	1	High Altitude Kit ●
4	121-4299	1	Fuel Line Kit				
5	139-0631	1	Tube-Breather				

● Not illustrated

Engine Assembly No. 2

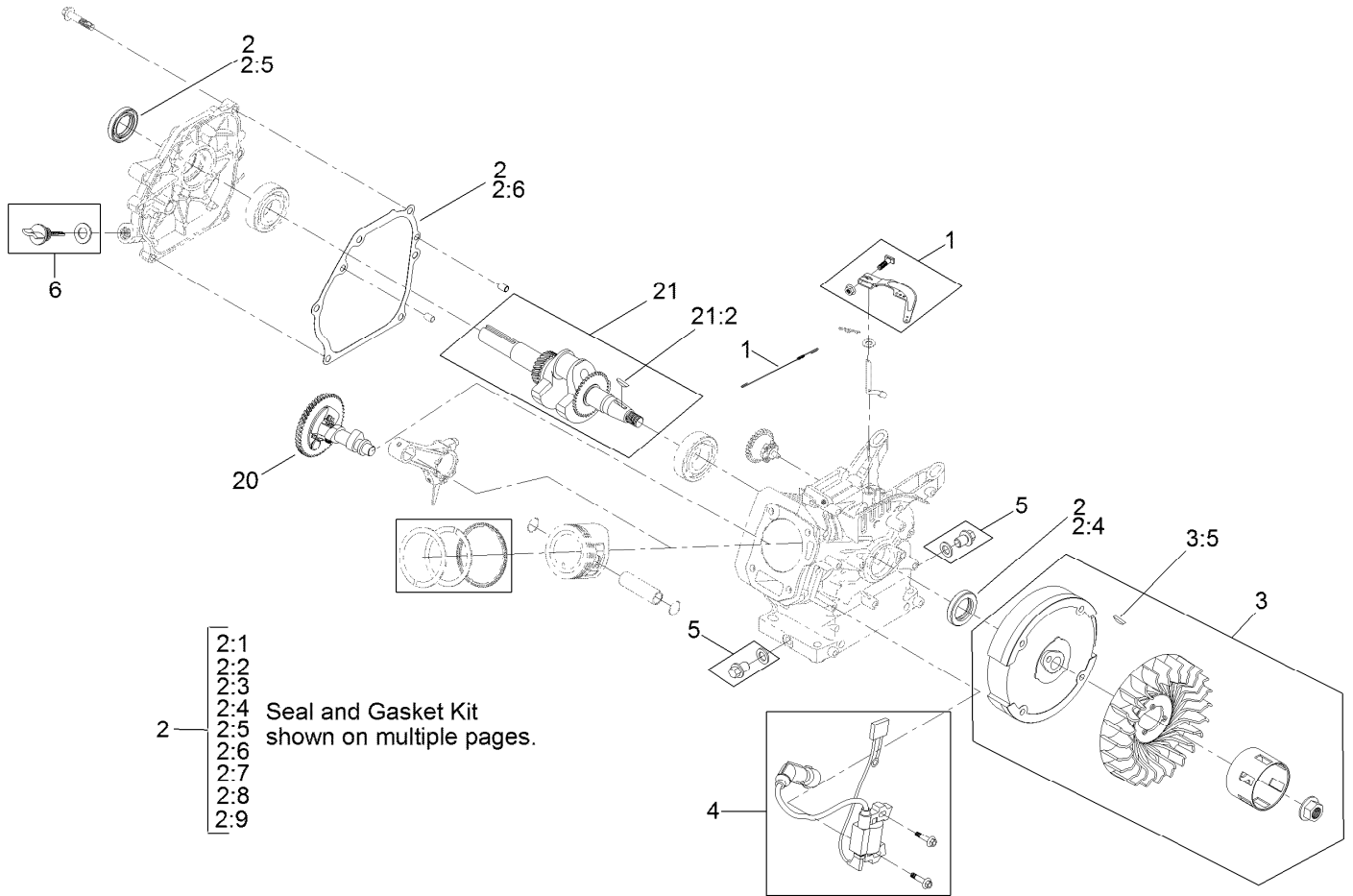

Engine Assembly No. 2 (continued)

<i>Ref.</i>	<i>Part Number</i>	<i>Qty.</i>	<i>Description</i>	<i>Ref.</i>	<i>Part Number</i>	<i>Qty.</i>	<i>Description</i>
1	136-7765	1	Governor Kit	2:9	121-0080	1	Gasket-Carburetor
2	127-9001	1	Gasket And Seal Kit	3	127-9004	1	Recoil Flywheel Kit
2:1	121-0109	1	Gasket-Cover, Valve	3:5	120-4320	1	Key-Woodruff
2:2	121-0167	1	Gasket-Exhaust	4	136-7766	1	Ignition Kit
2:3	127-9000	1	Gasket-Head, Cylinder	5	119-1923	2	Drain Plug Kit
2:4	121-0208	1	Seal-Oil	6	127-9374	1	Dipstick And O-Ring Kit
2:5	121-0209	1	Seal-Oil	20	133-9836	1	Camshaft
2:6	121-0105	1	Gasket-Cover, Crankcase	21		1	Crankshaft ASM ●
2:7	121-0076	1	Gasket-Carburetor	21:2	120-4320	1	Key-Woodruff
2:8	121-0078	1	Gasket-Carburetor				

● Not serviced separately

Engine Assembly No. 3

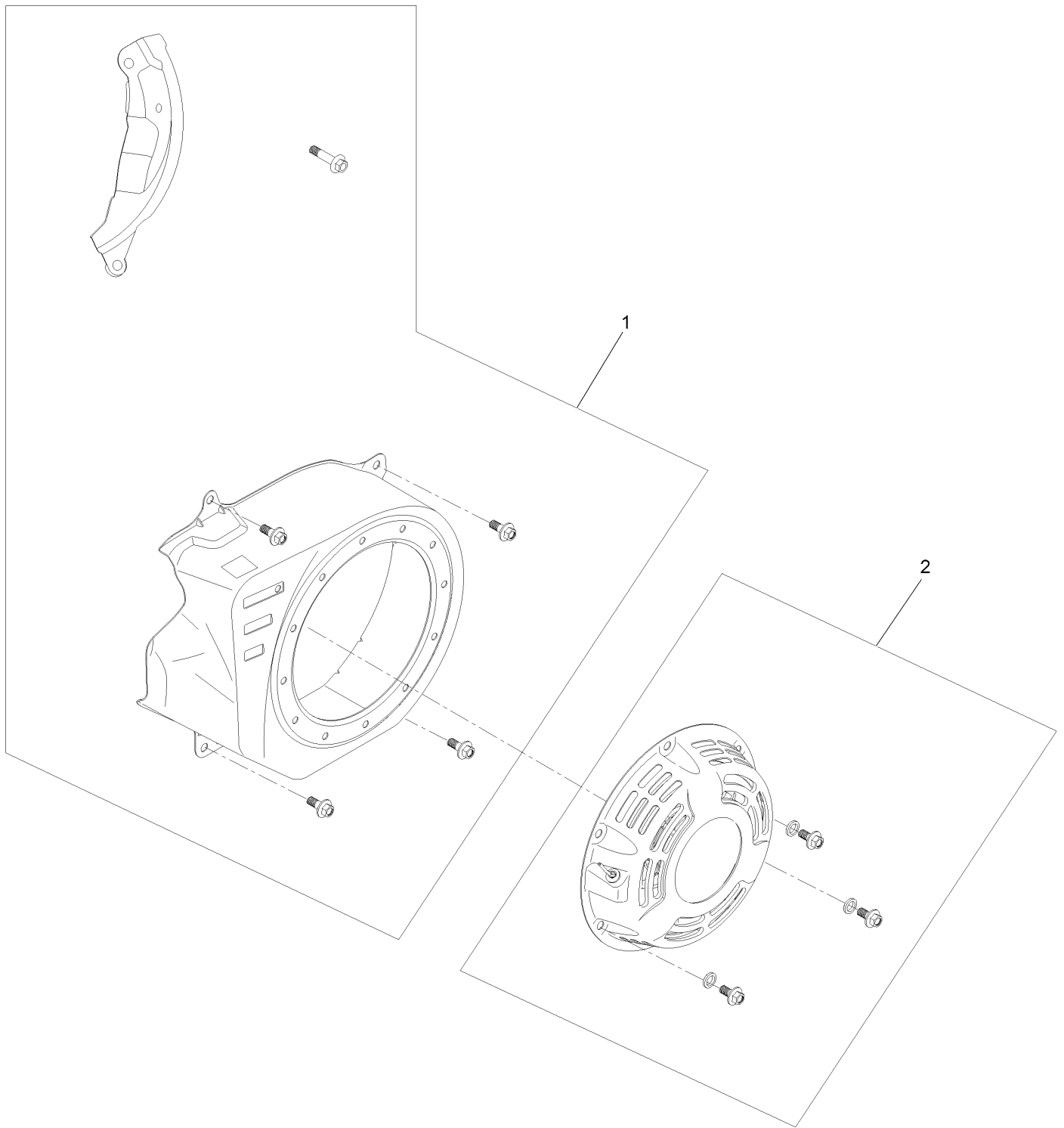

Engine Assembly No. 3 (continued)

<i>Ref.</i>	<i>Part Number</i>	<i>Qty.</i>	<i>Description</i>
1	127-9010	1	Blower Shroud Kit
2	121-4252	1	Recoil Kit

Shroud Assembly

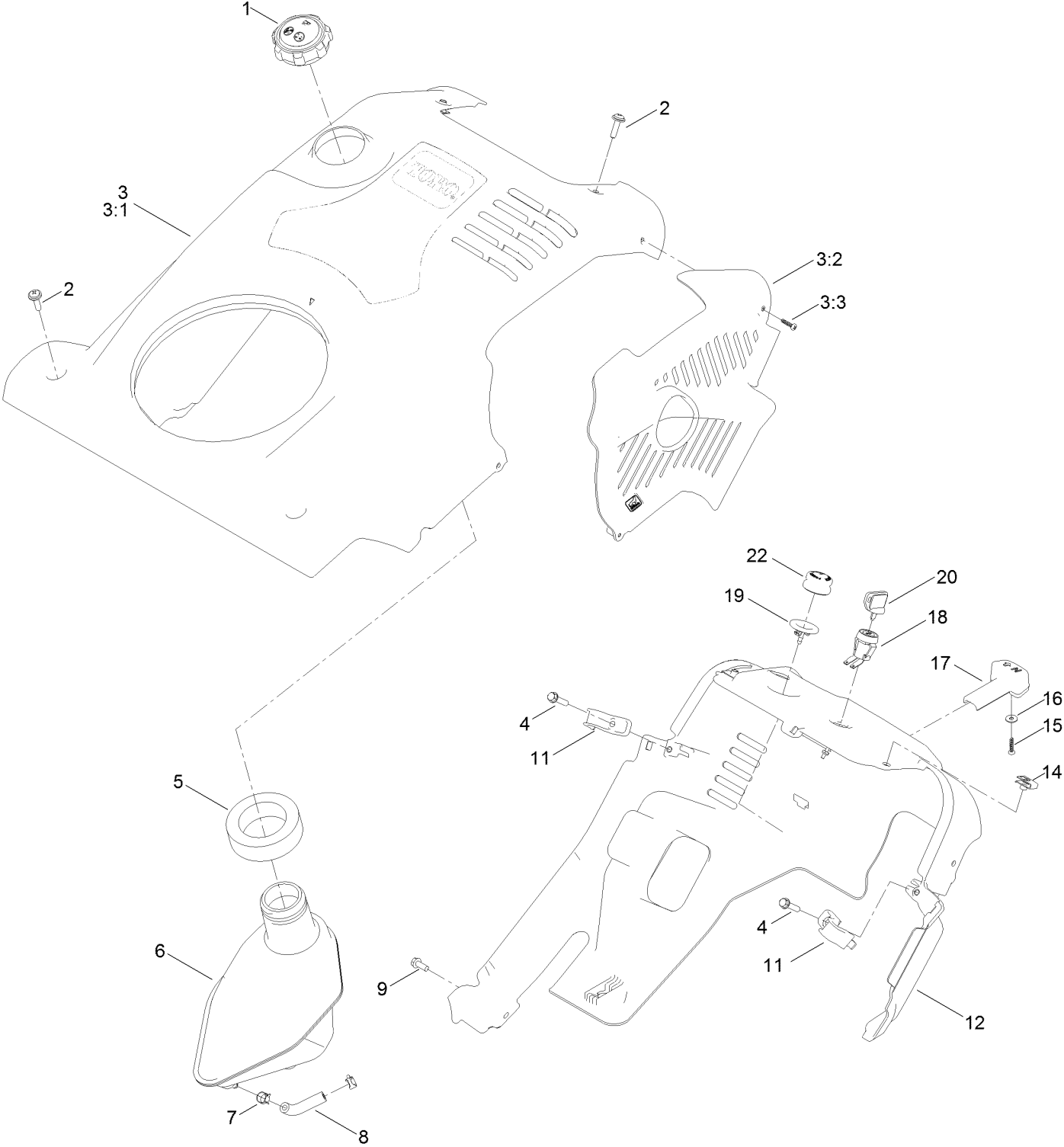

Shroud Assembly (continued)

<i>Ref.</i>	<i>Part Number</i>	<i>Qty.</i>	<i>Description</i>	<i>Ref.</i>	<i>Part Number</i>	<i>Qty.</i>	<i>Description</i>
1	138-3624	1	Cap-Gas	9	32144-85	1	Screw-HWH
2	137-3013	4	Screw-PPH, Sems	11	108-4947	2	Clip-Shroud
3	133-5542	1	Shroud ASM	12	117-6036	1	Shroud-Lower
3:1	133-5543	1	Shroud	14	107069	2	Clip
3:2	117-6035	1	Baffle-Exhaust	15	94-4496	1	Screw-PPH
3:3	94-4496	1	Screw-PPH	16	137-3079	1	Washer-Plain
4	137-3100	2	Screw-Plastite, HWH	17	117-9100	1	Knob-Choke
5	114-3773	1	Seal-Tank	18	40-5940	1	Switch
6	120-9848	1	Tank-Fuel, Gas	19	44-2750	1	Body-Primer
7	2412-98	2	Clamp-Hose	20	63-8360	1	Key-Ignition
8	109-0660	1	Hose-Fuel	22	66-7460	1	Bulb-Primer

Chute Control Assembly

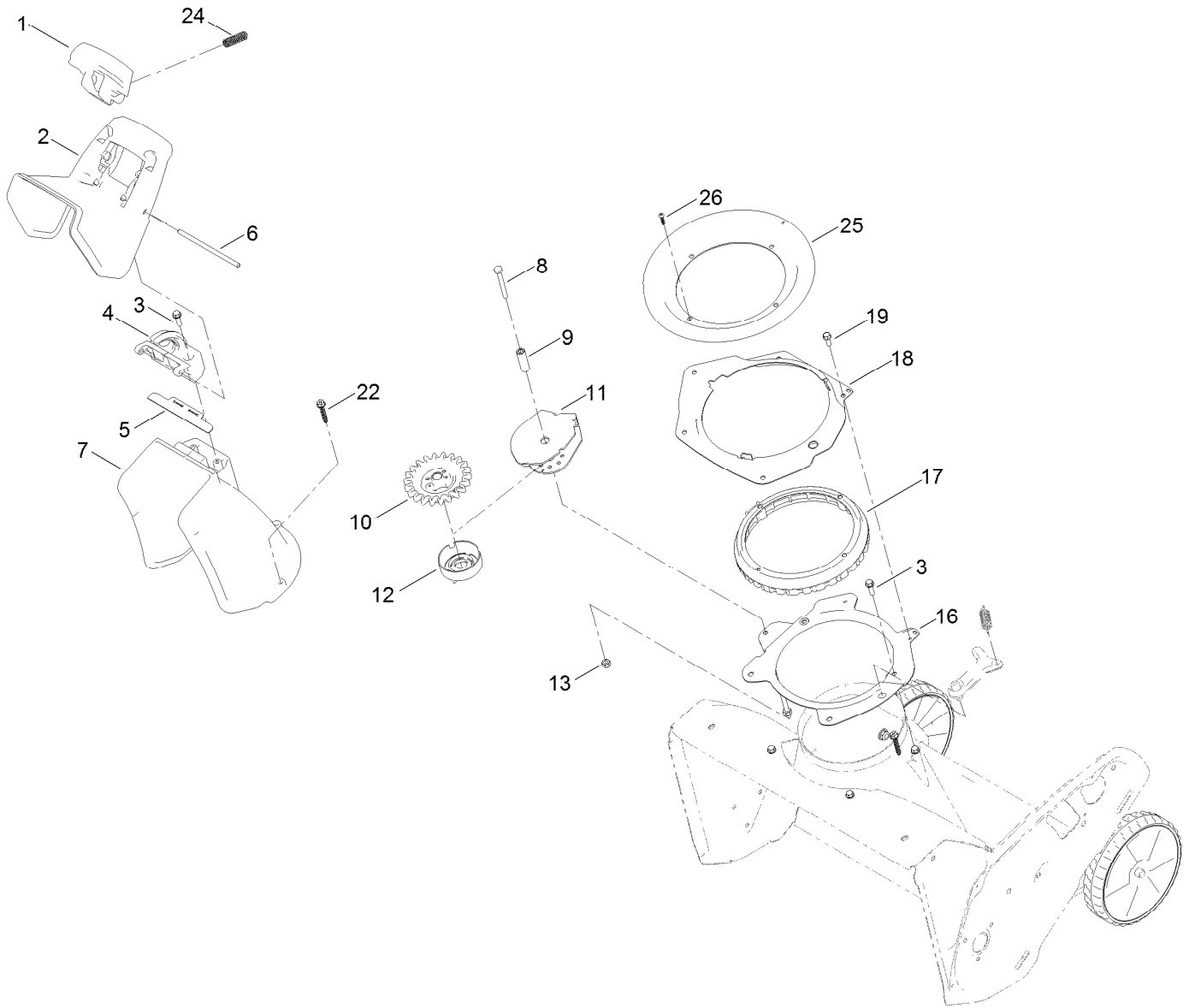

Chute Control Assembly (continued)

<i>Ref.</i>	<i>Part Number</i>	<i>Qty.</i>	<i>Description</i>	<i>Ref.</i>	<i>Part Number</i>	<i>Qty.</i>	<i>Description</i>
1	108-4941	1	Trigger-Deflector	12	114-3792	1	Retainer-Cable
2	117-9121	1	Deflector-Chute, CE	13	137-3088	1	Nut-Hex
3	137-3099	6	Screw-Plastite, HWH	16	108-4883-03	1	Ring-Support, Chute
4	108-4942	1	Hinge-Ratchet, Deflector	17	108-4882	1	Ring-Chute, Gear
5	114-3790	1	Seal-Deflector	18	108-4874-03	1	Retainer-Ring, Chute
6	136-8672	1	Pin-Hinge, Deflector	19	32144-85	2	Screw-HWH
7	108-4939	1	Chute	22	137-3012	3	Screw-Plastite, HWH
8	137-3034	1	Screw-HH	24	136-7136	2	Spring-Compression
9	108-4877	1	Spacer-Sleeve, Pinion	25	114-3772	1	Seal-Ring, Chute
10	108-4875	1	Pinion-Gear	26	94-4496	1	Screw-PPH
11	108-4900-03	1	Bracket-Pinion				

Handle Assembly

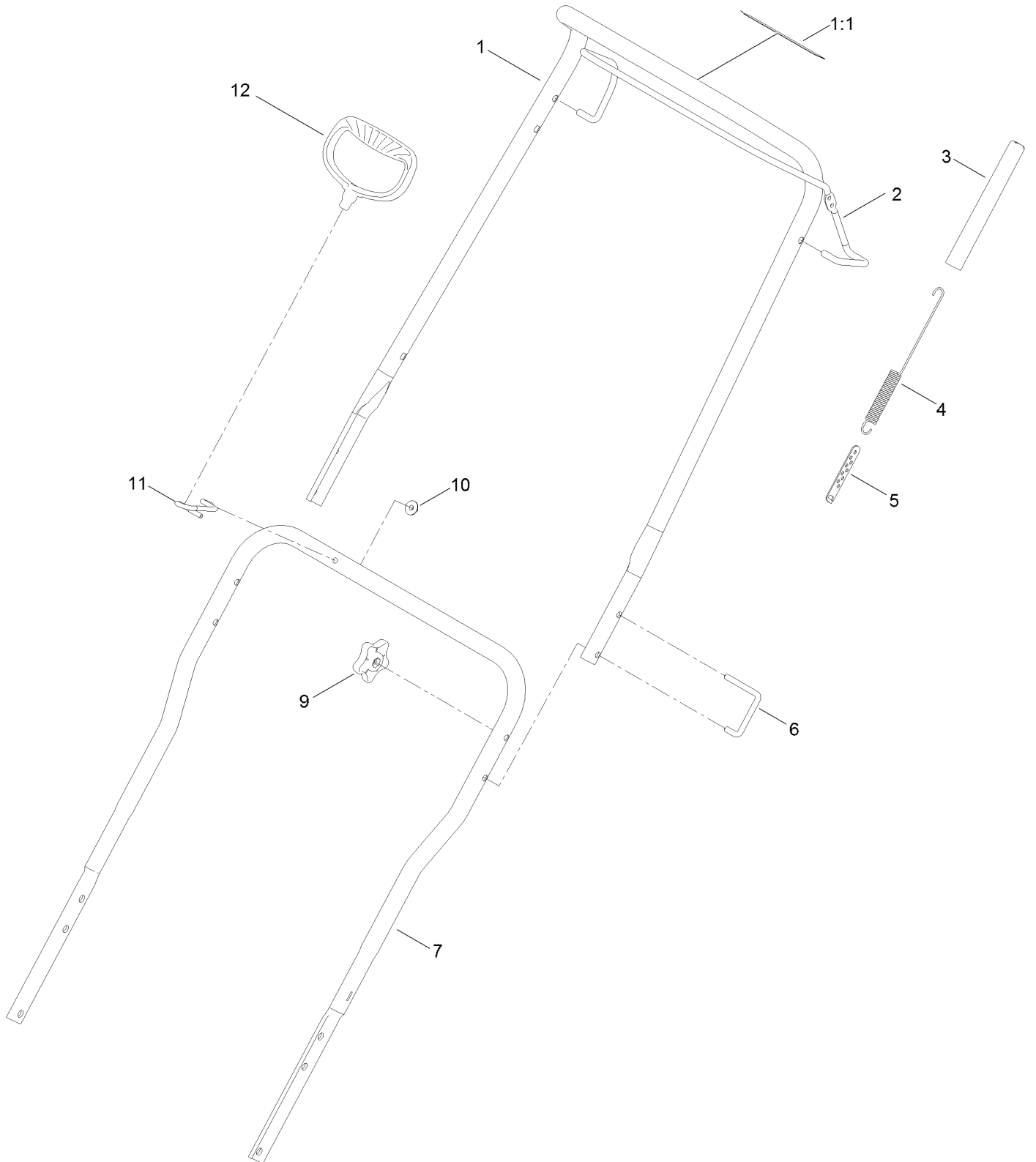

Handle Assembly (continued)

<i>Ref.</i>	<i>Part Number</i>	<i>Qty.</i>	<i>Description</i>	<i>Ref.</i>	<i>Part Number</i>	<i>Qty.</i>	<i>Description</i>
1	114-3768	1	Upper Handle ASM	6	136-7130	2	Lock-Handle
1:1	94-2577	1	Decal-Drive, Rotor	7	127-5956-03	1	Handle-Lower
2	114-3780-03	1	Bail-Control	9	114-3779	2	Knob-Handle
3	114-3796	1	Cover-Spring	10	137-3016	1	Nut-HF
4	125-1148	1	Spring-Extension, Clutch	11	136-7135	1	Guide-Rope
5	136-7126	1	Adjuster-Cable, Clutch	12	117-9104	1	Handle-Recoil

Slider Track Assembly

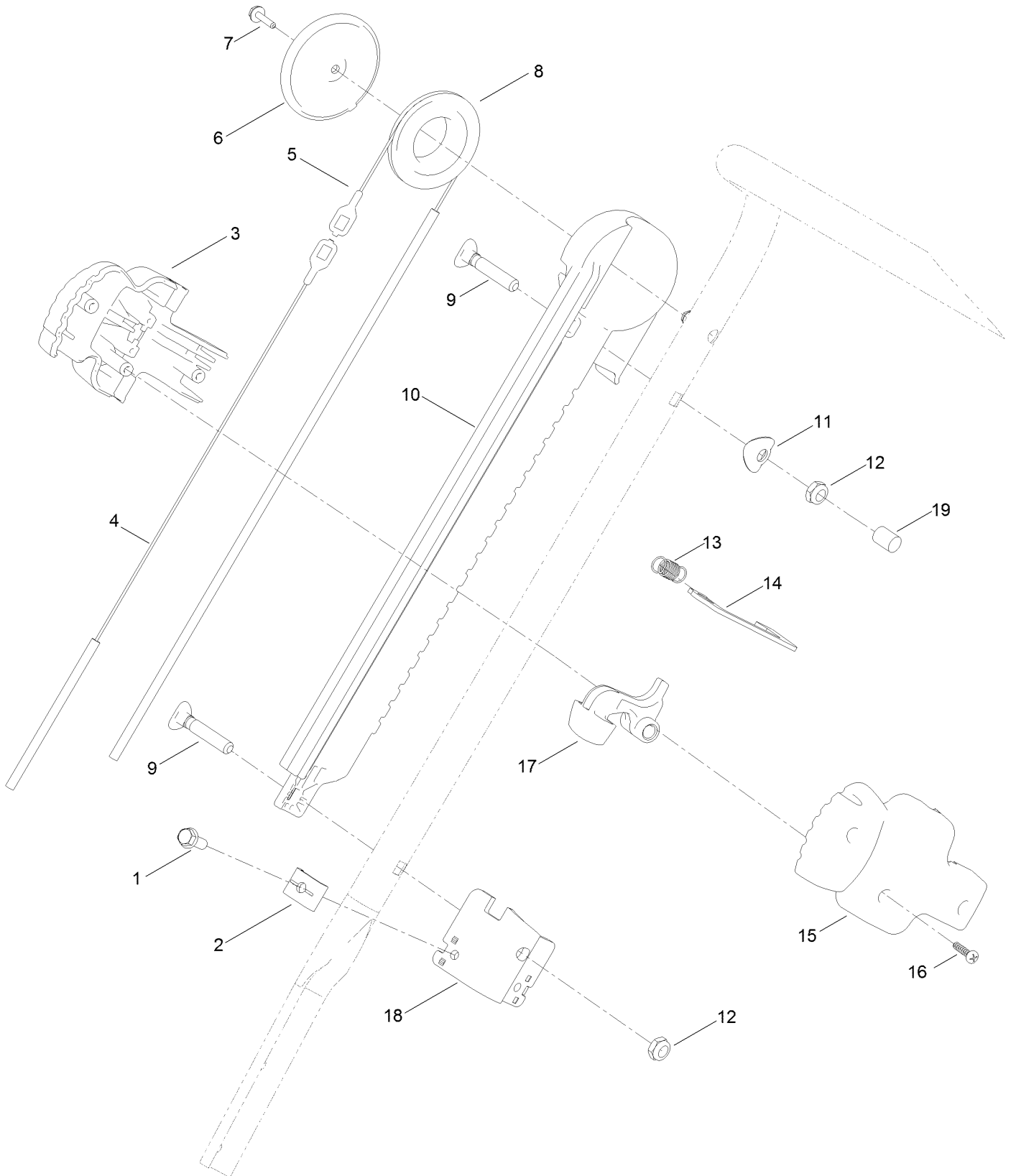

Slider Track Assembly (continued)

<i>Ref.</i>	<i>Part Number</i>	<i>Qty.</i>	<i>Description</i>	<i>Ref.</i>	<i>Part Number</i>	<i>Qty.</i>	<i>Description</i>
1	32144-85	2	Screw-HWH	11	137-3009	1	Washer-Cup
2	136-7191	2	Clamp-Cable	12	137-3089	2	Nut-Hex
3	108-4912	1	Handle-Slider, RH	13	108-4914	1	Spring-Trigger
4	108-4897	1	Cable-Chute, Short	14	136-7131	1	Lock Plate-Chute
5	108-4898	1	Cable-Chute, Long	15	108-4911	1	Handle-Slider, LH
6	108-4931	1	Cover-Pulley	16	94-4496	3	Screw-PPH
7	137-3110	1	Screw-Plastite, HWH	17	108-4913	1	Trigger
8	108-4907	1	Pulley-Slider	18	136-7132	1	Bracket-Cable
9	137-3008	2	Screw-Handle	19	125-7943	1	Cap-Thread, Screw
10	108-4899	1	Track-Slider				

Attachments and Accessories

For 38563 CCR 6053 R Quick Clear Snowthrower

Product Name	Model/Part
High Altitude Kit	127-9037
Engine Maintenance Kit.....	138-0699
Long Life Rotor Blade Kit	38205
Paddle Replacement Kit	38261
Case of 24 20-Ounce Bottles 5W30 Winter Oil	38908
Toro Snow Oil 0W30 Synthetic 20-Ounce Bottle	38913

Notes:



Count on it.