



Dingo[®] 222

Traction Unit

Model Number 22304—990001 & Up

PROTOTYPE

Operator's Manual

Introduction

Thank you for purchasing a Toro product.

All of us at Toro want you to be completely satisfied with your new product, so feel free to contact your local Authorized Service Dealer for help with service, genuine replacement parts, or other information you may require.

Whenever you contact your Authorized Service Dealer or the factory, always know the model and serial numbers of your product. These numbers will help the Service Dealer or Service Representative provide exact information about your specific product. The two numbers are stamped into a plate mounted on left rear side of frame.

For your convenience, write the product model and serial numbers in the space below.

Model No: _____
Serial No. _____

Read this manual carefully to learn how to operate and maintain your product correctly. Reading this manual will help you and others avoid personal injury and damage to the product. Although we design, produce and market safe, state-of-the-art products, you are responsible for using the product properly and safely. You are also responsible for training persons, who you allow to use the product, about safe operation.

The warning system in this manual identifies potential hazards and has special safety messages that help you and others avoid personal injury, even death. DANGER, WARNING and CAUTION are signal words used to identify the level of hazard. However, regardless of the hazard, be extremely careful.



DANGER signals an extreme hazard that will cause serious injury or death if the recommended precautions are not followed.

WARNING signals a hazard that may cause serious injury or death if the recommended precautions are not followed.

CAUTION signals a hazard that may cause minor or moderate injury if the recommended precautions are not followed.

Two other words are also used to highlight information. "Important" calls attention to special mechanical information and "Note" emphasizes general information worthy of special attention.

The left and right side of the machine is determined by standing on the platform in the normal operator's position.

 **WARNING:** 

The engine exhaust from this product contains chemicals known to the State of California to cause cancer, birth defects, or other reproductive harm.

Contents

	Page		Page
Safety	2	Driving Forward or Backward	20
Safe Operating Practices	2	Stopping the Traction Unit	20
Slope Chart	6	Moving a Non Functioning Traction Unit .	20
Safety and Instruction Decals	7	Using the Cylinder Locks	21
Assembly	8	Attachments	21
Loose Parts	8	Securing the Traction Unit for Transport ..	23
Installing the Valve Lever	8	Maintenance	24
Activating the Battery	8	Service Interval Chart	24
Specifications	11	Servicing the Air Cleaner	25
General Specifications	11	Servicing the Engine Oil	26
Attachments	11	Servicing the Spark Plugs	28
Stability Data	12	Greasing and Lubrication	29
Before Operating	13	Replacing the Fuel Filter	30
Adding Fuel	13	Draining the Fuel Tank	30
Using Stabilizer/Conditioner	14	Servicing the Hydraulic System	31
Checking the Oil Level	14	Servicing the Traction Drive Chains	32
Removing Debris from the Traction Unit .	15	Servicing the Battery	33
Checking the Hydraulic Fluid	15	Cleaning and Storage	34
Tire Pressure	16	Troubleshooting	36
Operation	17	Warranty	Back Cover
Controls	17		
Starting and Stopping the Engine	19		

The enclosed engine owner’s manual is supplied for California emission control regulation information on emission systems, maintenance and warranty.

Keep this engine owner’s manual with your unit. Should this engine owner’s manual become damaged or illegible, replace it immediately. Replacements may be ordered through the engine manufacturer.

Safety

Improper use or maintenance by the operator or owner can result in injury. To reduce the potential for injury, comply with these safety instructions and always pay attention to the safety alert  symbol, which means CAUTION, WARNING, or DANGER—“personal safety instruction.” Failure to comply with the instruction may result in personal injury or death.

Safe Operating Practices

This product is capable of amputating hands and feet. Always follow all safety instructions to avoid serious injury or death.

 WARNING
POTENTIAL HAZARD <ul style="list-style-type: none">• Engine exhaust contains carbon monoxide, which is an odorless, deadly poison.
WHAT CAN HAPPEN <ul style="list-style-type: none">• Carbon monoxide can kill you and is also known to the State of California to cause birth defects.
HOW TO AVOID THE HAZARD <ul style="list-style-type: none">• Do not run engine indoors or in an enclosed area.

Because in some areas there are local, state, or federal regulations requiring that a spark-arrester be used on engines, a spark-arrester is available as an option for the traction unit. If a spark-arrester is required, contact your Toro dealer. Genuine Toro approved spark-arresters are approved by the USDA Forestry Service. It is a violation of the State of California PRC Section 4442 to use or operate the engine on any forest-covered, brush-covered, or grass-covered land, unless the engine is equipped with a spark-arrester, maintained in working order, or the engine is constricted, equipped, and maintained for the prevention of fire.

General Operation

- Read, understand, and follow all instructions in the operator’s manual, in the video, and on the traction unit before starting. Also, read all attachment manuals where supplied
- Allow only responsible adults who are familiar with the instructions to operate the traction unit.
- Do not operate the traction unit or attachments while wearing sandals, tennis shoes, sneakers, or shorts. Always wear long pants and substantial shoes. Wearing safety glasses, safety shoes, hearing protection, and a hard hat are advisable and may be required by some local ordinances and insurance regulations.
- Ensure that the area is clear of other people before operating the traction unit. Stop the traction unit if anyone enters the area.
- Never carry passengers on attachments or on the traction unit.
- Always look down and behind before and while backing.
- Do not place your feet under the platform.
- Slow down before turning. Sharp turns on any terrain may cause loss of control.
- Never leave a running traction unit unattended. Always lower the loader arms, stop the engine, and remove the key before dismounting.
- Do not exceed the rated operating capacity, as the traction unit may become unstable which may result in loss of control.
- Do not carry a load with the arms raised. Always carry loads close to the ground. Do not step off of the platform with the load raised.

- Do not over-load the attachment and always keep the load level when raising the loader arms. Logs, boards, and other items could roll down the loader arms, injuring you.
- Never jerk the control levers; use a steady motion.
- Keep your hands, feet, hair, and loose clothing away from any moving parts.
- Operate only in daylight or good artificial light.
- Do not operate the traction unit while under the influence of alcohol or drugs.
- Watch for traffic when operating near or crossing roadways.
- Use extra care when loading or unloading the traction unit onto a trailer or truck.
- Do not touch parts which may be hot from operation. Allow them to cool before attempting to maintain, adjust, or service.
- Locate and mark underground utilities before digging to avoid the risk of electrical shock or explosion. Do not dig in marked areas.
- Raising the loader arms on a slope will affect the stability of the machine. Whenever possible, keep the loader arms in the lowered position when on slopes.
- Removing an attachment on a slope will make the rear of the traction unit heavy. Refer to the Stability Data section, page 12, to determine whether the attachment can be safely removed on the slope.
- Remove obstacles such as rocks, tree limbs, etc. from the work area. Watch for holes, ruts, or bumps, as uneven terrain could overturn the traction unit. Tall grass can hide obstacles.
- Use slow speed on slopes. Before starting the engine, put the pump selector lever in the slow (turtle) position so that you will not have to stop or shift while on the slope.
- Follow the recommendations in the attachment manuals for the use of counterweights to improve stability.
- Use only Toro approved attachments. Attachments can change the stability and the operating characteristics of the traction unit. Warranty may be voided if used with unapproved attachments.

Slope Operation

Slopes are a major factor related to loss-of-control and tip-over accidents, which can result in severe injury or death. All slopes require extra caution.

- Do not operate the traction unit on hillsides or slopes exceeding the angles recommended in the Stability Data section, page 12, and those in the attachment operator's manual. See also the slope chart on page 6.
- **Operate up and down slopes with the heavy end of the traction unit uphill.** Weight distribution changes. An empty bucket will make the rear of the traction unit the heavy end, and a full bucket will make the front of the traction unit the heavy end. Most other attachments will make the front of traction unit the heavy end.
- Keep all movements on slopes slow and gradual. Do not make sudden changes in speed or direction.
- Avoid starting or stopping on a slope. If tires lose traction, proceed slowly, straight down the slope.
- Check for overhead clearances (i.e. branches, doorways, electrical wires) before driving under any objects and do not contact them.
- Avoid turning on slopes. If you must turn, turn slowly and keep the heavy end of the traction unit uphill.
- Do not operate near drop-offs, ditches, or embankments. The traction unit could suddenly turn over if a wheel goes over the edge of a cliff or ditch, or if an edge caves in.

- Do not operate on wet grass. Reduced traction could cause sliding.
- Do not park the traction unit on a hillside or slope without lowering the attachment to the ground and chocking the wheels.
- Do not try to stabilize the traction unit by putting your foot on the ground.

Children

Tragic accidents can occur if the operator is not alert to the presence of children. Children are often attracted to the traction unit and the work activity. Never assume that children will remain where you last saw them.

- Keep children out of the work area and under the watchful care of another responsible adult.
- Be alert and turn the traction unit off if children enter the area.
- Before and while backing, look behind and down for small children.
- Never carry children. They may fall off and be seriously injured or interfere with safe traction unit operation.
- Never allow children to operate the traction unit.
- Use extra care when approaching blind corners, shrubs, trees, the end of a fence, or other objects that may obscure vision.

Service

- Stop the engine and disconnect the spark plug wires before performing any service, repairs, maintenance, or adjustments.
- If any maintenance or repair requires the loader arms to be in the raised position, secure the arms in the raised position with the hydraulic cylinder locks included with traction unit.
- Never run a traction unit inside a closed area.

- Keep nuts and bolts tight. Keep equipment in good condition.
- Never tamper with safety devices. Check safety systems for proper operation before each use.
- Keep the traction unit free of grass, leaves, or other debris build-up. Clean up oil or fuel spillage. Allow the traction unit to cool before storing.
- Use extra care when handling gasoline and other fuels. They are flammable and vapors are explosive.
 - Use only an approved container.
 - Never remove the gas cap or add fuel when the engine is running. Allow the engine to cool before refueling. Do not smoke.
 - Never refuel the traction unit indoors.
 - Never store the traction unit or fuel container inside where there is an open flame, such as near a water heater or furnace.
 - Never fill a container while it is inside a vehicle, trunk, pick-up bed, or any surface other than the ground.
 - Keep container nozzle in contact with the tank during filling.
- Stop and inspect the equipment if you strike an object. Make any necessary repairs before restarting.
- Use only genuine replacement parts to ensure that original standards are maintained.
- Battery acid is poisonous and can cause burns. Avoid contact with skin, eyes, and clothing. Protect your face, eyes, and clothing when working with a battery.
- Battery gases can explode. Keep cigarettes, sparks and flames away from the battery.

PROTOTYPE

- Keep your body and hands away from pin hole leaks or nozzles that eject high pressure hydraulic fluid. Use cardboard or paper to find hydraulic leaks. Hydraulic fluid escaping under pressure can penetrate skin and cause injury requiring surgery within a few hours by a qualified surgeon or gangrene may result.

PROTOTYPE

Slope Chart

Read all safety instructions on pages 2-4.

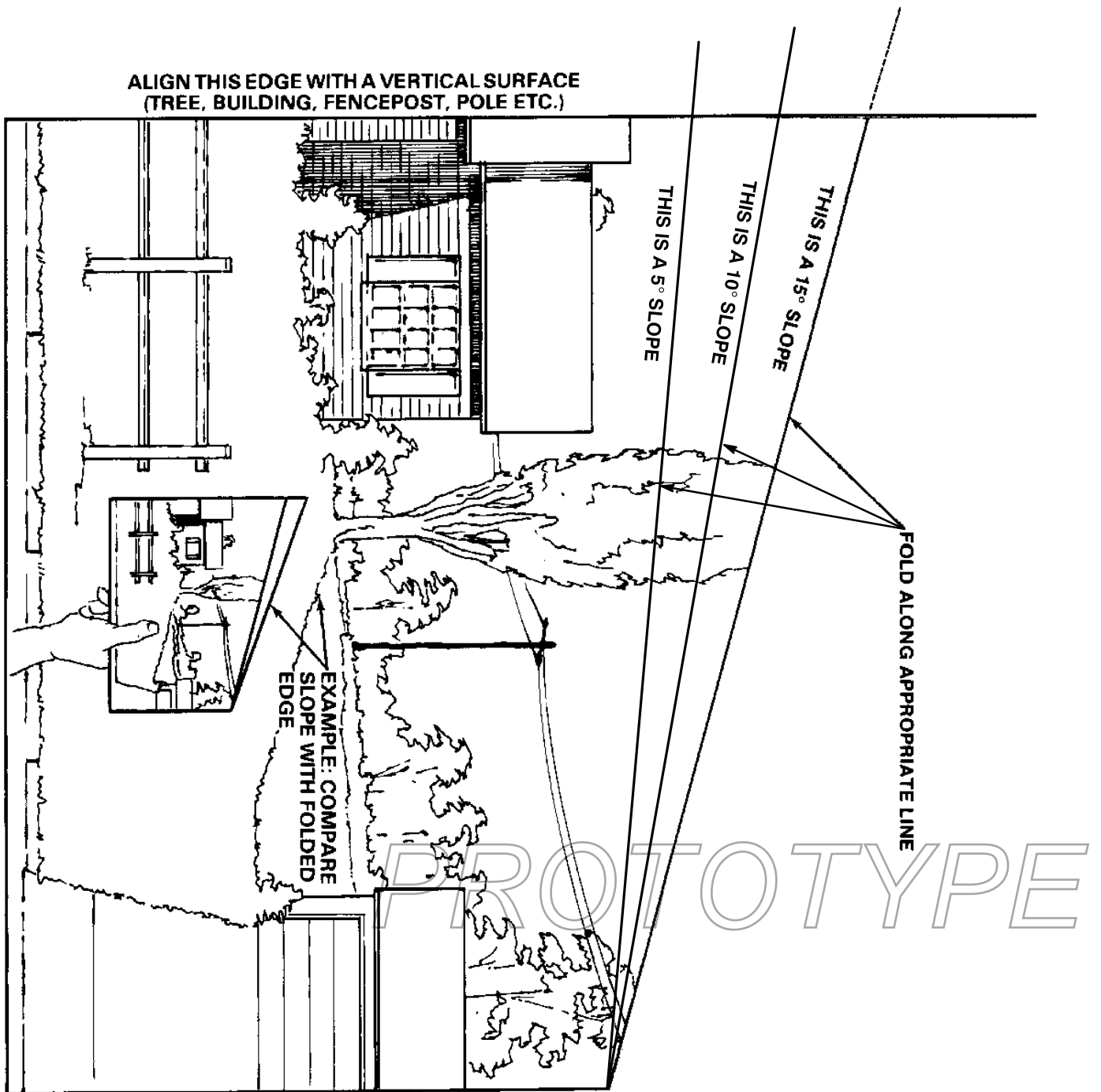

Safety and Instruction Decals



Safety decals and instructions are easily visible to the operator and are located near any area of potential danger. Replace any decal that is damaged or lost.

CAUTION

SECURE QUICK ATTACH BEFORE OPERATING MACHINE.

RATED OPERATING CAPACITY 515 LBS.

98-4682

On Loader Cross Bar
(Part No. 98-4682)

HYDRAULIC OIL ONLY

USE MOBIL 424

85-4730

Near Oil Fill
(Part No. 85-4730)

DANGER

TO MINIMIZE THE RISK OF ACCIDENTS:

- ALWAYS OPERATE WITH HEAVY END POINTED UP HILL.
- ALWAYS CARRY LOADS LOW.
- NEVER STEP OFF OPERATOR PLATFORM WITH LOAD RAISED.
- NEVER JERK THE CONTROL LEVERS. USE A STEADY, EVEN MOTION.
- NEVER OPERATE THE CONTROL LEVERS UNLESS YOU ARE STANDING WITH BOTH FEET ON THE PLATFORM AND FIRMLY HOLDING THE GRIP HANDLES.

READ OPERATOR'S MANUAL. SEE COMPLETE MANUAL AVAILABLE TO THE REGIONAL COMPLETE MODEL NUMBER TO THE TOP COMPANY 1111 LYRIABLE AVE. S. BLOOMINGTON, MN 55420-1101

On Control Panel
(Part No. 99-1385)

AUXILIARY POWER

BE SURE AUXILIARY HYDRAULICS ARE IN NEUTRAL BEFORE STARTING ENGINE

98-4677

On Front Control Panel
(Part No. 98-4677)

DANGER

TO MINIMIZE THE RISK OF ACCIDENTS, INJURY, OR DEATH:

- OPERATOR MUST BE SKILLED AND TRAINED IN OPERATION.
- NEVER USE WHEN UNDER THE INFLUENCE OF ALCOHOL OR DRUGS.
- USE SAFELY, MACHINE IS NOT A TOY.
- STOP ENGINE AND REMOVE KEY BEFORE LEAVING MACHINE. WAIT FOR ALL MOVEMENT TO STOP BEFORE SERVICING.
- USE CYLINDER LOCKS IF SERVICING WHILE LIFT ARMS ARE RAISED.
- KEEP GUARDS, COVERS AND OTHER SAFETY DEVICES IN PLACE.
- WEAR CLOSE FITTING PROTECTIVE CLOTHING AND SHOES.
- KEEP HANDS, FEET AND CLOTHING AWAY FROM ALL MOVING PARTS.
- NEVER SMOKE WHILE FUELING. STOP ENGINE BEFORE FUELING.
- NEVER RUN ENGINE WITHOUT ADEQUATE VENTILATION.

- KEEP CHILDREN AND OTHER PEOPLE A SAFE DISTANCE AWAY.
- NEVER LET CHILDREN OPERATE THE MACHINE.
- NEVER CARRY CHILDREN OR OTHER PASSENGERS.
- LOOK DOWN AND BEHIND BEFORE AND WHILE BACKING UP.
- GO SLOW AND AVOID SHARP TURNS ON SLOPES.
- ALWAYS PLACE IMPLEMENT ON GROUND WHEN LEAVING MACHINE. USE WHEEL CHOCKS WHEN PARKING ON A SLOPE.
- FIRMLY HOLD THE GRAB HANDLES WHEN OPERATING. NEVER PLACE FEET UNDER THE PLATFORM.
- KNOW THE WORK AREA. CHECK FOR HOLES AND OVERHEAD CLEARANCES. AVOID OVERHEAD POWER LINES.
- KNOW LOCATION OF UNDERGROUND UTILITIES BEFORE YOU DIG.

Inside Left Loader Arm (1)
(Part No. 98-9051)

SPEED LIMITER

98-8220

On Front Control Panel
(Part No. 98-8220)

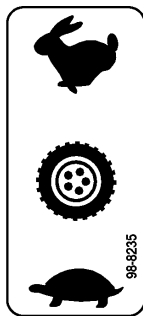

On Front Control Panel
(Part No. 98-8235)

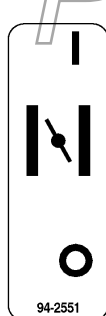

On Control Panel
(Part No. 94-2551)

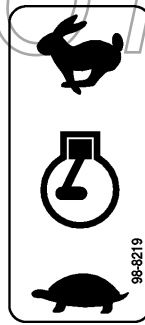

On Control Panel
(Part No. 98-8219)

WARNING

KEEP HANDS AWAY FROM THIS AREA WHILE OPERATING LIFT.

80-8010

On Both Sides of Frame and Loader, and on Top of Loader Arms (6)
(Part No. 80-8010)

Assembly

Loose Parts

Note: Use the chart below to verify all parts have been shipped.

DESCRIPTION	QTY.	USE
Valve Lever	1	Install valve lever
Key	2	Start the engine
Oil filter	1	Break-in oil change
Chain link	2	Spare parts

Installing the Valve Lever

1. Thread the lever into the pump selector valve (Fig. 1).

Note: The lever should be installed with the bend toward the operator.

2. Tighten the jam nut on the lever to lock it in position.

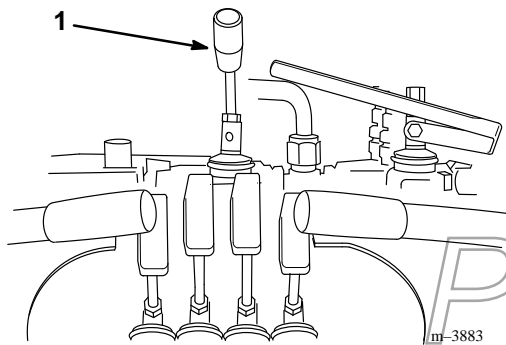

Figure 1

1. Pump selector lever

Activating the Battery

The traction unit is shipped with a dry battery. Purchase bulk electrolyte with 1.260 specific gravity from a local battery supply outlet.

1. Remove the wing nut and bolt securing the battery clamp and strip (under the clamp) and remove the clamp and strip (Fig. 2).

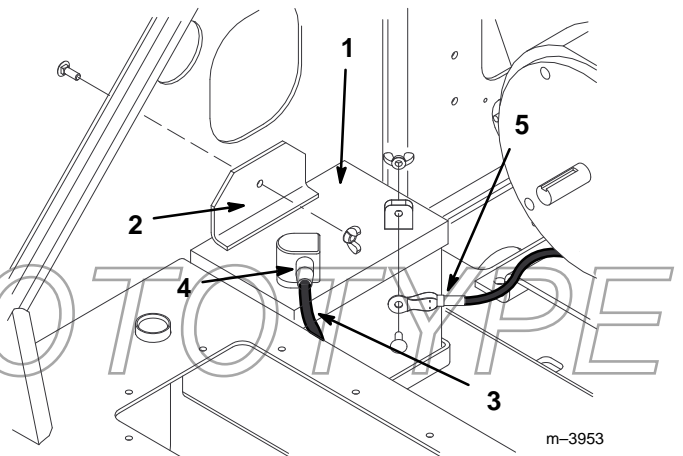



Figure 2

1. Battery
2. Battery clamp
3. Positive cable
4. Rubber cover
5. Negative cable

- Gently push the hydraulic hoses aside and lift the battery out of the chassis.

DANGER

POTENTIAL HAZARD

- Battery electrolyte contains sulfuric acid which is a deadly poison and it causes severe burns.

WHAT CAN HAPPEN

- If you drink electrolyte you could die or if it gets onto your skin you will be burned.

HOW TO AVOID THE HAZARD

- Do not drink electrolyte and avoid contact with skin, eyes or clothing. Wear safety glasses to shield your eyes and rubber gloves to protect your hands.
- Fill the battery where clean water is always available for flushing the skin.
- Follow all instructions and comply with all safety messages on the electrolyte container.

- Charge the battery at a rate of 4 amperes or less for 4 hours (12 volts).

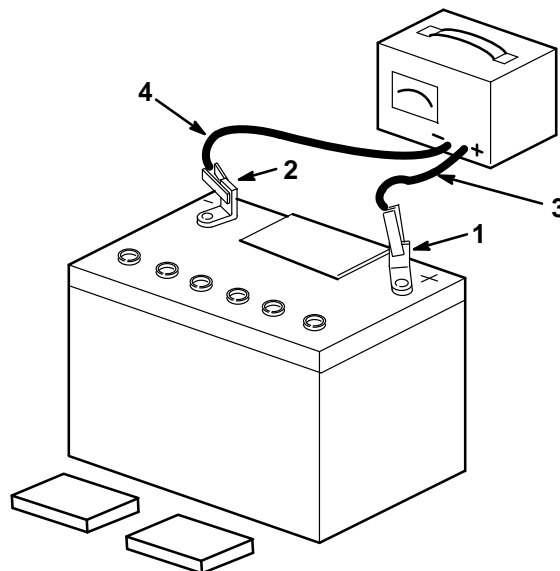

1254

Figure 4

- | | |
|------------------|---------------------------|
| 1. Positive post | 3. Charger red (+) wire |
| 2. Negative post | 4. Charger black (-) wire |

- Remove filler caps from the battery. Slowly pour electrolyte into each cell until the electrolyte level is up to the lower part of the tube (Fig. 3).

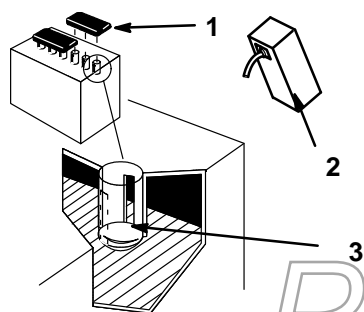

1262

Figure 3

- | | |
|----------------|---------------------------|
| 1. Filler caps | 3. Lower part of the tube |
| 2. Electrolyte | |

- Leave the covers off and connect a 3 to 4 amp battery charger to the battery posts (Fig. 4).

WARNING

POTENTIAL HAZARD

- Charging battery produces gasses.

WHAT CAN HAPPEN

- Battery gasses can explode.

HOW TO AVOID THE HAZARD

- Keep cigarettes, sparks and flames away from battery.

- When the battery is fully charged, disconnect the charger from the electrical outlet and from the negative and positive battery posts (Fig. 4).

- Slowly pour electrolyte into each cell until the level is once again up to the upper line on the battery case (Fig. 3) and install covers.

8. Install the battery into the chassis (Fig. 2).
9. Secure the battery in the chassis with the battery clamp, strip, and wing nut (Fig. 2).
10. Using the bolt and wing nut supplied with the battery, connect the positive (red) cable to the positive (+) battery post (Fig. 2). Slide the rubber cover over the battery post.
11. Using the bolt and wing nut supplied with the battery, connect the negative (black) cable to the negative (-) battery post (Fig. 2).

Note: Ensure that the battery cables do not contact any sharp edges or each other.

PROTOTYPE

Specifications

General Specifications

Overall width	40.5 inches	(103 cm)
Overall length	60.0 inches	(152 cm)
Overall height	49.0 inches	(125 cm)
Weight	1565 lbs	(710kg)
Rated operating capacity (with 200 lb operator)	515 lbs	(234 kg)
Tipping capacity (with 200 lb operator)	1030lbs	(467kg)
Wheelbase	28.5 inches	(72 cm)
Dump height (with std. bucket)	48.75 inches	(124 cm)
Reach – fully raised (with std. bucket)	26.0 inches	(66 cm)
Height to hinge pin (std bucket in highest position)	66.0 inches	(168 cm)

Note: Specifications and design are subject to change without notice.

Attachments



Many attachments are available for use with the traction unit. These attachments allow you to perform many different functions with the traction unit such as hauling materials, digging holes, grading, and more. Contact your Toro dealer for a list of all approved Dingo attachments and accessories.

IMPORTANT: Use only Toro approved attachments.

PROTOTYPE

Stability Data

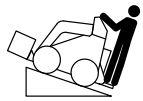
The following table lists the maximum slope recommended for the traction unit in the positions listed in the table. Slopes over the listed degree may cause the traction unit to become unstable. The data in the table assumes that the loader arms are fully lowered and that the factory installed tires are on the traction unit, inflated to the recommended pressure; raised arms and other tire types or pressure may affect the stability.

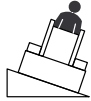
Configuration	Maximum Recommended Slope when Operating with:		
	Front Uphill 	Rear Uphill 	Side Uphill 
Traction unit without attachment	8°	20°	17°
Traction unit with counterweight, without attachment	5°	21°	17°
Traction unit with an attachment rated with one of the following stability ratings for each slope position:*			
A	25°	25°	20°
B	18°	19°	17°
C	15°	16°	14°
D	10°	10°	9°
E	5°	5°	5°

* In each attachment manual is a set of three stability ratings, one for each hill position. To determine the maximum slope you can traverse with the attachment installed, find the degree of slope that corresponds to the stabilities ratings of the attachment.

Example: If the attachment installed on the traction unit has a Front Uphill rating of B, a Rear Uphill rating of D, and a Side Uphill rating of C, then you could drive forward up a 18° slope, rearward up a 10° slope, or sideways on a 14° slope, as listed in the above table.

PROTOTYPE

Before Operating

Before operating, check the fuel and oil level, remove debris from the traction unit, and check the tire pressure. Also, ensure that the area is clear of people and debris. You should also know and have marked the locations of all utility lines.

Adding Fuel

DANGER

POTENTIAL HAZARD

- In certain conditions gasoline is extremely flammable and highly explosive.

WHAT CAN HAPPEN

- A fire or explosion from gasoline can burn you, others, and cause property damage.

HOW TO AVOID THE HAZARD

- Fill the fuel tank outdoors, in an open area, when the engine is cold. Wipe up any gasoline that spills.
- Do not fill the fuel tank completely full. Add gasoline to the fuel tank until the level is 1/4" to 1/2" (6 mm to 13 mm) below the bottom of the filler neck. This empty space in the tank allows gasoline to expand.
- Never smoke when handling gasoline, and stay away from an open flame or where gasoline fumes may be ignited by a spark.
- Store gasoline in an approved container and keep it out of the reach of children. Never buy more than a 30-day supply of gasoline.

DANGER

POTENTIAL HAZARD

- When fueling, under certain circumstances, a static charge can develop, igniting the gasoline.

WHAT CAN HAPPEN

- A fire or explosion from gasoline can burn you, others, and cause property damage.

HOW TO AVOID THE HAZARD

- Always place gasoline containers on the ground away from your vehicle before filling.
- Do not fill gasoline containers inside a vehicle or on a truck or trailer bed because interior carpets or plastic truck bed liners may insulate the container and slow the loss of any static charge.
- When practical, remove gas-powered equipment from the truck or trailer and refuel the equipment with its wheels on the ground.
- If this is not possible, then refuel such equipment on a truck or trailer from a portable container, rather than from a gasoline dispenser nozzle.
- If a gasoline dispenser nozzle must be used, keep the nozzle in contact with the rim of the fuel tank or container opening at all times until fueling is complete.

Use unleaded regular gasoline (85 pump octane minimum). Leaded regular gasoline may be used if unleaded regular is not available.

IMPORTANT: Never use methanol, gasoline containing methanol, or gasohol containing more than 10% ethanol because the fuel system could be damaged. Do not mix oil with gasoline.

Filling the Fuel Tank

1. Park the traction unit on a level surface, lower the loader arms, and stop the engine.
2. Remove the key and allow the engine to cool.
3. Clean around the fuel tank cap and remove it.
4. Add unleaded regular gasoline to each fuel tank, until the level is 1/4 to 1/2 inch (6 mm to 13 mm) below the bottom of each filler neck.

IMPORTANT: This space in the tank allows gasoline to expand. Do not fill the fuel tank completely full.

5. Install the fuel tank cap securely. Wipe up any gasoline that may have spilled.

Using Stabilizer/Conditioner

Use a fuel stabilizer/conditioner in the fuel tank to provide the following benefits:

- Keeps gasoline fresh during storage of 90 days or less. For longer storage, drain the fuel tank.
- Cleans the engine while it runs.
- Eliminates gum-like varnish buildup in the fuel system, which causes hard starting.

IMPORTANT: Do not use fuel additives containing methanol or ethanol.

Add the correct amount of gas stabilizer/conditioner to the gas.

Note: A fuel stabilizer/conditioner is most effective when mixed with fresh gasoline. To minimize the chance of varnish deposits in the fuel system, use fuel stabilizer at all times.

Checking the Oil Level

1. Park the traction unit on a level surface, lower the loader arms, and stop the engine.
2. Remove the key and allow the engine to cool.
3. Clean around the oil dipstick (Fig. 5).
4. Pull out the dipstick and wipe the metal end clean (Fig. 5).
5. Slide the dipstick fully into the dipstick tube (Fig. 5).
6. Pull the dipstick out and look at the metal end.
7. If the oil level is low, clean around the oil filler cap and remove the cap (Fig. 5).
8. Slowly pour only enough oil into the valve cover to raise the level to the F (full) mark.

IMPORTANT: Do not overfill the crankcase with oil because the engine may be damaged.

9. Replace the filler cap and dipstick.

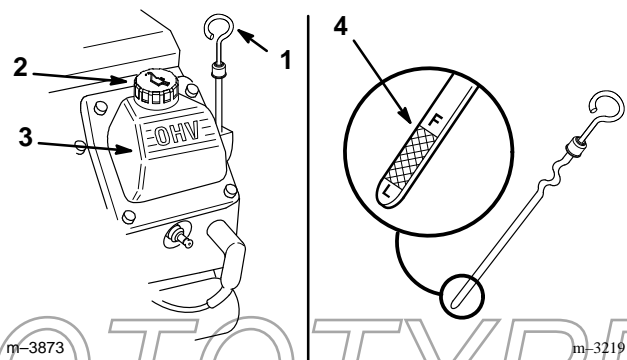

Figure 5

- | | |
|-----------------|----------------|
| 1. Oil dipstick | 3. Valve cover |
| 2. Filler cap | 4. Metal end |

Removing Debris from the Traction Unit

IMPORTANT: Operating the engine with a blocked grass screen, dirty or plugged cooling fins, and/or cooling shrouds removed, will result in engine damage from overheating.

1. Park the traction unit on a level surface, raise the loader arms, and install the cylinder locks; refer to Using the Cylinder Locks, page 21.
2. Stop the engine and remove the key.
3. Clean any debris from the grill before each use and/or during use, if required.
4. Wipe away debris from the air cleaner before each use and/or during use, and empty the pre-cleaner jar, if required.
5. Clean any debris build-up on the engine with a brush or blower before each use.

IMPORTANT: It is preferable to blow dirt out, rather than washing it out. If water is used, keep it away from electrical items and hydraulic valves. Do not use a high-pressure washer. High-pressure washing can damage the electrical system and hydraulic valves or deplete grease.

6. Remove and store the cylinder locks (refer to Using the Cylinder Locks, page 21), and lower the loader arms.

Checking the Hydraulic Fluid

Check the hydraulic fluid level before the engine is first started and after every 25 operating hours.

Hydraulic Tank Capacity: 17.25 gal. (67 l)

Use only Group 1 ISO type 46/68 anti-wear hydraulic fluids, recommended for ambient temperatures consistently below 100° F, such as Toro Hy-Pro, Mobil Fluid 424, or other equivalent fluid.

IMPORTANT: Use only the group 1 ISO type 46/68 anti-wear hydraulic fluids. Other fluids could cause system damage.

1. Remove the attachment, if one is installed; refer to Removing an Attachment, page 23.
2. Park the traction unit on a level surface, lower the loader arms, stop the engine, and remove the key.
3. Clean the area around the filler neck of the hydraulic tank (Fig. 6).
4. Remove the cap from the filler neck and check the fluid level on the dipstick (Fig. 6).

The fluid level should be at the mark on the dipstick.

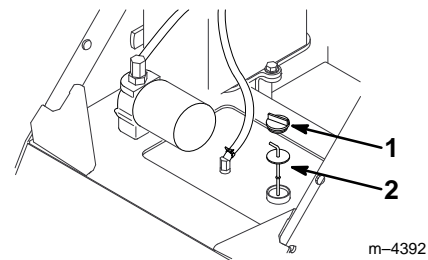

Figure 6

1. Filler neck cap
2. Dipstick

5. If the level is low, add enough fluid to raise it to the proper level.
6. Install the cap on the filler neck.

Tire Pressure

Maintain the air pressure in the tires as specified.
Check the tires when they are cold to get the most accurate reading.

Pressure: 20–30 psi

Note: Use a lower tire pressure (20 psi) when operating in sandy soil conditions to provide better traction in the loose soil.

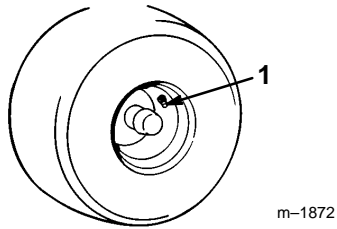

Figure 7

1. Valve stem

PROTOTYPE

Operation

CAUTION

POTENTIAL HAZARD

- Operator could fall off platform.

WHAT CAN HAPPEN

- Operator could be seriously injured.

HOW TO AVOID THE HAZARD

- Do not move any of the control levers unless standing with both feet on the platform and hands holding the hand grips.

Controls

Become familiar with all the controls (Fig. 8) before you start the engine and operate the traction unit.

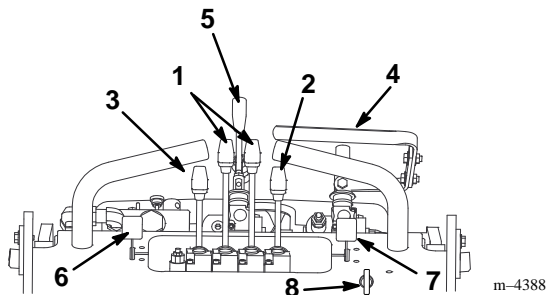

Figure 8

- | | |
|-------------------------------|------------------------|
| 1. Traction control levers | 5. Pump selector lever |
| 2. Attachment tilt lever | 6. Throttle lever |
| 3. Loader arm lever | 7. Choke lever |
| 4. Auxiliary hydraulics lever | 8. Key switch |

Key Switch

The key switch, used to start and stop the engine, has three positions: off, run, and start.

To start the engine, rotate the key to the start position. Release the key when engine starts and it will move automatically to the run position.

To stop the engine, rotate the key to the off position.

Throttle Lever

Move the control forward to increase the engine speed and rearward to decrease speed.

Choke Lever

Before starting a cold engine, move the choke lever fully forward. After the engine starts, regulate the choke to keep the engine running smoothly. As soon as possible, move the choke lever rearward as far as possible. A warm engine requires little or no choking.

Traction Control Levers

To move forward, move the traction control levers forward. To move rearward, move the traction control levers rearward.

To go straight, move both traction control levers equally.

To turn, move the lever located on the side you want to turn back toward the neutral position while keeping the other lever engaged.

The farther you move the traction control levers in either direction, the faster the traction unit will move in that direction.

To slow or stop, move the traction control levers to neutral.

Attachment Tilt Lever

To tilt the attachment forward, slowly push the attachment tilt lever forward.

To tilt the attachment rearward, slowly pull the attachment tilt lever rearward.

Loader Arm Lever

To lower the loader arms, slowly push the loader arm lever forward.

To raise the loader arms, slowly pull the loader arm lever rearward.

Auxiliary Hydraulics Lever

To operate a hydraulic attachment in forward direction, slowly pull the auxiliary hydraulics lever rearward.

To operate a hydraulic attachment in reverse direction, slowly push the auxiliary hydraulics lever forward.

Pump Selector Lever

Move the pump selector lever to the fast (rabbit) position to set the traction drive, loader arms, and attachment tilt to high speed and the auxiliary hydraulics to low speed.

Move the pump selector lever to the slow (turtle) position to set the auxiliary hydraulics to high speed and the traction drive, loader arms, and attachment tilt to low speed.

WARNING

POTENTIAL HAZARD

- **If the pump selector lever is moved while the traction unit is in motion, the traction unit will either stop suddenly or accelerate quickly.**
- **If the traction unit is operated with the pump selector lever in an intermediate position, the traction unit will operate erratically and may be damaged.**

WHAT CAN HAPPEN

- **You could be thrown forward or backwards, resulting in injury.**
- **If the traction unit accelerates quickly, you could lose control of the traction unit and injure bystanders or yourself.**
- **You could lose control of the traction unit, severely injuring yourself or others.**
- **The traction unit could be damaged.**

HOW TO AVOID THE HAZARD

- **Do not move the pump selector lever when the traction unit is in motion.**
- **Do not operate the traction unit when the speed selector is in any intermediate position (i.e., any position other than fully forward or fully rearward).**

Flow Divider Control

The traction unit hydraulics (i.e., the traction drive, loader arms, and attachment tilt) work on a separate hydraulic circuit from the auxiliary hydraulics for powering attachments; however, the two systems share the same hydraulic pumps. Using the flow divider control (Fig. 9), you can vary the speed of the traction unit hydraulics by diverting hydraulic flow to the auxiliary hydraulics circuit. The flow divider allows you to divide the flow of fluid in varying degrees to slow the traction unit. Thus, the more hydraulic flow you divert to the auxiliary hydraulics, the slower the traction unit hydraulics will move.

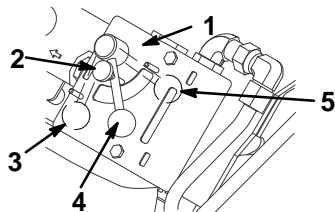

Figure 9

- | | |
|-------------------------|------------------------------|
| 1. Flow divider control | 4. 10 to 11 o'clock position |
| 2. Knob | 5. 9 o'clock position |
| 3. 12 o'clock position | |

- Move the flow divider control to the twelve-o'clock position to provide maximum speed to the traction unit hydraulics.

Use this setting for fast operation of the traction unit.

- Move the flow divider control between the twelve-o'clock and nine-o'clock positions to slow the traction unit hydraulics and fine tune the speed.

Use a setting in this range with attachments with hydraulics where you need to both run the attachment and move the traction unit hydraulics, such as the auger, boring unit, hydraulic blade, and tiller.

- Move the control to the nine-o'clock position to transfer all hydraulic flow to the auxiliary hydraulics of the attachment.

In this setting, the traction unit hydraulics will not work. Use this setting with hydraulic attachments that do not require the traction unit hydraulics. There are currently no attachments that require the nine-o'clock position; however, the trencher does work best if you set it close to nine-o'clock so that the traction unit will creep slowly when trenching.

Note: The flow divider control can be fixed in place by turning the knob on the control clockwise until it contacts the dial (Fig. 9).

Starting and Stopping the Engine

Starting the Engine

1. Stand on the platform.
2. Move the auxiliary hydraulics valve lever to neutral.
3. Move the throttle lever midway between slow (turtle) and fast (rabbit) positions.

4. Move the choke lever fully forward before starting a cold engine.

Note: A warm or hot engine may not require choking.

5. Turn the ignition key to the start position. When the engine starts, release the key.

IMPORTANT: Do not engage the starter for more than 10 seconds at a time. If the engine fails to start, allow a 30 second cool-down period between attempts. Failure to follow these instructions can burn out the starter motor.

6. After the engine starts, gradually move the choke to rearward. If the engine stalls or hesitates, move the choke forward again until the engine warms up.

7. Move the throttle lever to desired setting.

IMPORTANT: If you run the engine at high speeds when the hydraulic system is cold (i.e., when the ambient air temperature is around freezing or lower), you could damage the hydraulic system. When starting the engine in cold conditions, allow the engine to run in the middle throttle position for 2 to 5 minutes before moving the throttle to fast (rabbit).

Stopping the Engine

1. Move the throttle lever to the slow (turtle) position.
2. Lower the loader arms to the ground.
3. Turn the ignition key off.

Note: If the engine has been working hard or is hot, let it idle for a minute before turning the ignition key off. This helps cool the engine before it is stopped. In an emergency, the engine may be stopped immediately.

Driving Forward or Backward

The throttle control regulates the engine speed as measured in rpm (revolutions per minute). Place the throttle lever in the fast (rabbit) position for best performance.

Note: Throttle position can be utilized to operate at slower speeds.

To drive the traction unit, complete the following actions as necessary:

- To move forward, move the traction control levers forward.
- To move rearward, move the traction control levers rearward.
- To go straight, move both traction control levers equally.
- To turn, move the lever located on the side you want to turn toward the neutral position while keeping the other lever engaged.
- To slow or stop, move the traction control levers to neutral.

Note: The farther you move the traction control levers in either direction, the faster the traction unit will move in that direction.

Stopping the Traction Unit

To stop the traction unit, move the traction control levers to neutral and the throttle lever to slow (turtle), lower loader arms to the ground, and turn the ignition key off to stop the engine. Remove the key.

CAUTION

POTENTIAL HAZARD

- Someone could move or attempt to operate the traction unit while it is unattended.

WHAT CAN HAPPEN

- Children or bystanders may be injured if they use the traction unit.

HOW TO AVOID THE HAZARD

- Always remove the ignition key when leaving the traction unit, even if just for a few seconds.

Moving a Non Functioning Traction Unit

IMPORTANT: Never tow or pull the traction unit. Rotating the wheels manually will cause damage to the hydraulic wheel motors.

1. Stop the engine.
2. Lift the traction unit off the ground, using the two lift points (Fig. 10) and move onto a trailer.

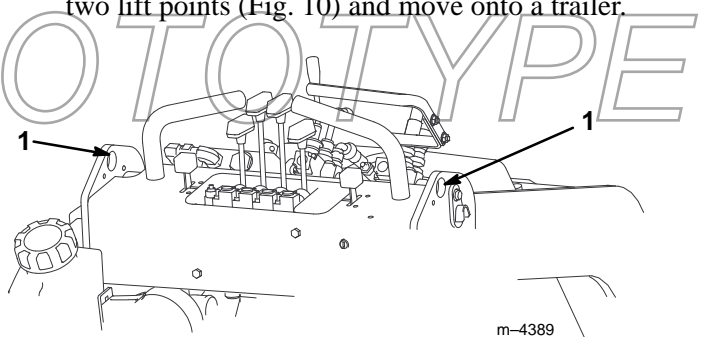

Figure 10

1. Lift points

Using the Cylinder Locks

WARNING

POTENTIAL HAZARD

- The loader arms may lower when in the raised position.

WHAT CAN HAPPEN

- Anyone under the loader arms may be injured or crushed.

HOW TO AVOID THE HAZARD

- Always install the cylinder locks when doing maintenance that requires raised loader arms.

Installing the Cylinder Locks

1. Start the engine.
2. Raise the loader arms to the fully raised position.
3. Stop the engine.
4. Position a loader arm cylinder lock over each lift cylinder rod (Fig. 11).
5. Secure each loader arm cylinder lock with a clevis pin and cotter pin (Fig. 11).

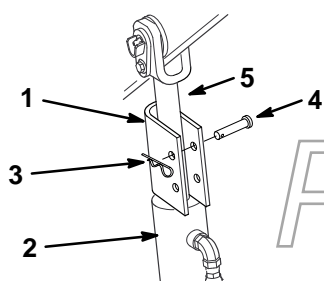

Figure 11

- | | |
|-------------------|----------------------|
| 1. Cylinder lock | 4. Clevis pin |
| 2. Lift cylinder | 5. Lift cylinder rod |
| 3. Hairpin cotter | |

6. Start the engine.

7. Slowly lower the loader arms until cylinder locks contact the cylinder body and rod end.
8. Stop the engine.

Removing/Storing the Cylinder Locks

1. Start the engine.
2. Raise the loader arms to the fully raised position.
3. Stop the engine.
4. Remove the clevis pin and cotter pin securing each cylinder lock.
5. Remove the cylinder locks.
6. Lower the loader arms.
7. Install the cylinder locks over the hydraulic hoses and secure them with the clevis pins and cotter pins (Fig. 12).

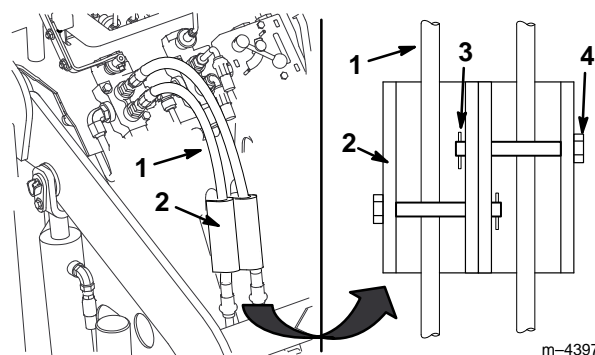

Figure 12

- | | |
|--------------------|-------------------|
| 1. Hydraulic hoses | 3. Hairpin cotter |
| 2. Cylinder locks | 4. Clevis pin |

Attachments

Connecting an Attachment

IMPORTANT: Use only Toro approved attachments. Attachments can change the stability and the operating characteristics of

the traction unit. The warranty of the traction unit may be voided if used with unapproved attachments.

IMPORTANT: Before installing the attachment, ensure that the mount plates are free of any dirt or debris.

1. Position the attachment on a level surface with enough space behind it to accommodate the traction unit.
2. Move the pump control lever to the turtle position.
3. Start the engine.
4. Slowly push the attachment tilt lever forward to tilt the attachment mount plate forward.
5. Position mount plate into the upper lip of the attachment receiver plate (Fig. 13).

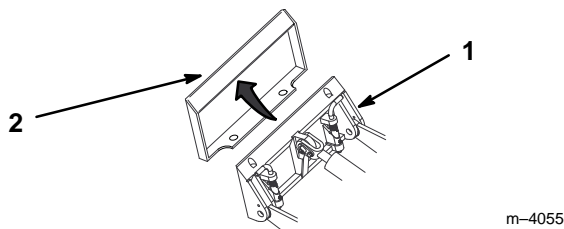

Figure 13

1. Mount plate
 2. Receiver plate
-

6. Raise the loader arms while tilting back the mount plate at the same time.

IMPORTANT: The attachment should be raised enough to clear the ground, and the mount plate should be tilted all the way back.

7. Stop the engine.
8. Engage the quick attach pins (Fig. 14).

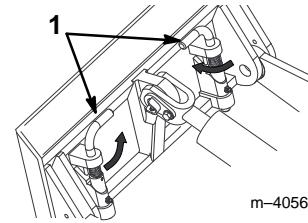

Figure 14

1. Quick attach pins (shown in engaged position)
-

Connecting the Hydraulic Hoses

If the attachment requires hydraulics for operation, connect the hydraulic hoses as follows:

1. Stop the engine.
2. Move the auxiliary hydraulics lever forward, backward, and back to neutral to relieve pressure at the hydraulic couplers.

IMPORTANT: Ensure that all foreign matter is cleaned from the hydraulic connections before making connections.

3. Remove the protective covers from the hydraulic couplers on the traction unit. Connect the covers together to prevent contamination during operation.
4. Slide the collars back on the hydraulic couplers and connect the attachment couplers to the traction unit couplers.

PROTOTYPE

 **WARNING**
POTENTIAL HAZARD

- Hydraulic fluid escaping under pressure can penetrate skin and cause injury.

WHAT CAN HAPPEN

- Fluid accidentally injected into the skin must be surgically removed within a few hours by a doctor familiar with this form of injury or gangrene may result.

HOW TO AVOID THE HAZARD

- Keep body and hands away from pin hole leaks or nozzles that eject high pressure hydraulic fluid.
- Use cardboard or paper to find hydraulic leaks, never use your hands.

5. Confirm that the connection is secure by pulling on the hoses.

Removing an Attachment

1. Lower the attachment to the ground
2. Stop the engine.
3. Disengage the quick attach pins by turning them to the outside.
4. If the attachment uses hydraulics, move the auxiliary hydraulics lever forward, backward, and back to neutral to relieve pressure at the hydraulic couplers.
5. If the attachment uses hydraulics, slide the collars back on the hydraulic couplers and disconnect them.
6. Connect the attachment hoses together to prevent hydraulic system contamination during storage.
7. Install the protective covers onto the hydraulic couplers on the traction unit.
8. Start the engine, tilt the mount plate forward, and back the traction unit away from the attachment.

Securing the Traction Unit for Transport

IMPORTANT: Do not operate or drive the traction unit on roadways.

IMPORTANT: When transporting the traction unit on a trailer, always use the following procedure:

1. Lower the loader arms.
2. Stop the engine.
3. Secure the traction unit to the trailer with chains or straps using the operator platform support openings to secure the rear of the traction unit and the loader arms/mount plate to secure the front of the traction unit.

PROTOTYPE

Maintenance

Service Interval Chart

Service Operation	Each Use	8 Hours	25 Hours	50 Hours	100 Hours	200 Hours	400 Hours	Yearly
Hydraulic Fluid—check level	Initial		X					
Hydraulic Fluid—change							X	
Hydraulic Filter—change		Initial				X		
Engine Oil—check level	X							
Engine Oil—change ¹			Initial		X			
Engine Oil Filter—change (200 hours or every other oil change) ¹						X		
Wheel Nuts—tighten		Initial						
Traction Drive Chain—lubricate				X				
Chassis—grease ²		X						
Foam Air Filter—clean ¹			X					
Paper Air Filter—replace ¹					X			
Spark Plug(s)—check						X		
Engine RPM (idle & full throttle)—check							X	
Gasoline—drain ³								X
Hydraulic lines—check					X			
Battery—check electrolyte					X			
Battery—charge, disconnect cables ³	Initial							X
Fuel Filter—replace						X		
Tires—check pressure	X							
Check/tighten all fasteners ³	X							X
Chipped Surfaces—paint ³								X

¹ More often in dusty, dirty conditions, ² Immediately **after** every washing, ³ Storage Service

! CAUTION

POTENTIAL HAZARD

- If you leave the key in the ignition switch, someone could start the engine.

WHAT CAN HAPPEN

- Accidental starting of the engine could seriously injure you or other bystanders.

HOW TO AVOID THE HAZARD

- Remove the key from the ignition switch and disconnect negative battery cable from battery before you do any maintenance.

Servicing the Air Cleaner

Foam Element: Clean and oil after every 25 operating hours.

Paper Element: Replace after every 100 operating hours.

Note: Service the air cleaner more frequently (every few hours) if operating conditions are extremely dusty or sandy.

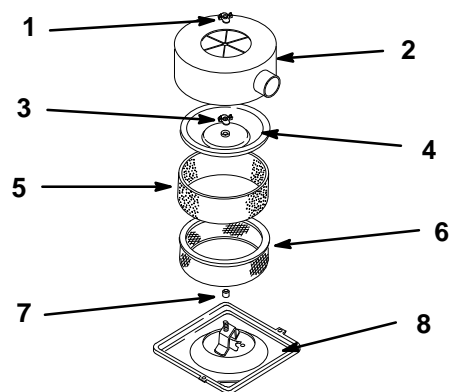

m-3866

Figure 15

Removing the Foam and Paper Elements

1. Lower the loader arms, stop the engine, and remove the key.
2. Clean around the air cleaner to prevent dirt from getting into the engine and causing damage.
3. Unscrew the wingnut and remove the air cleaner cover (Fig. 15).
4. Carefully slide the foam element off the paper element (Fig. 15).
5. Unscrew the cover nut and remove the cover and paper element (Fig. 15).
6. Inspect the paper element for dirt, tears, an oily film, and/or damage to the rubber seal. If it is dirty or damaged, discard it and obtain a new replacement.

IMPORTANT: Do not attempt to clean the paper element.

Cleaning the Foam Element

1. Wash the foam element in liquid soap and warm water. When the element is clean, rinse it thoroughly.
2. Dry the element by squeezing it in a clean cloth (do not wring).
3. Put one or two ounces of oil on the element (Fig. 16). Squeeze the element to distribute the oil.

IMPORTANT: Replace the foam element if it is torn or worn.

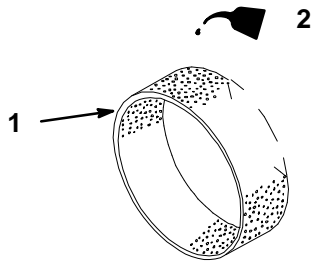

Figure 16

m-1213

1. Foam element 2. Oil

Servicing the Engine Oil

Change oil after the first 25 operating hours and then every 100 operating hours thereafter.

Note: Change oil more frequently when operating conditions are extremely dusty or sandy.

Oil Type: Detergent oil (API service SG or SH)

Crankcase Capacity: w/filter, 2.1 qt. (2 l)

Viscosity: See table below

USE THESE SAE VISCOSITY OILS

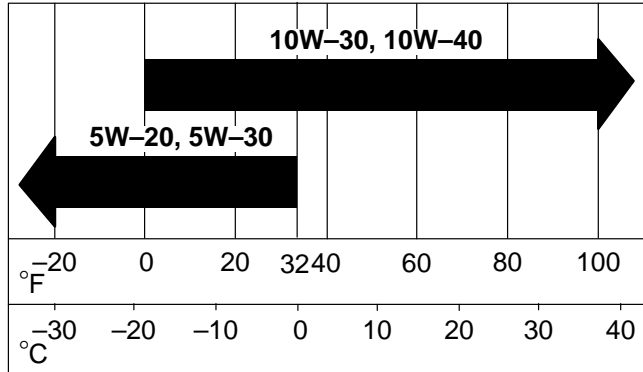

Installing the Foam and Paper Elements

IMPORTANT: To prevent engine damage, always operate the engine with the complete foam and paper air cleaner assembly installed.

1. Carefully slide the foam element onto the paper air cleaner element (Fig. 15).
2. Place the air cleaner assembly onto the air cleaner base (Fig. 15).
3. Install the air cleaner cover and secure with cover nut (Fig. 15).

PROTOTYPE

Changing/Draining Oil

1. Start the engine and let it run five minutes. This warms the oil so it drains better.
2. Park the traction unit so that the drain side is slightly lower than the opposite side to ensure that the oil drains completely.
3. Lower the loader arms, chock the wheels, stop the engine, and remove the key.

CAUTION

POTENTIAL HAZARD

- Components will be hot if the traction unit has been running.

WHAT CAN HAPPEN

- Touching hot components can cause burns.

HOW TO AVOID THE HAZARD

- Allow the traction unit to cool before performing maintenance or any touching components.

4. Place one end of a hose on the drain valve and the other end in a pan. Open the drain valve by turning it counter-clockwise, pulling out as you turn it (Fig. 17).
5. When oil has drained completely, close the drain valve and remove the hose.

Note: Dispose of the used oil at a certified recycling center.

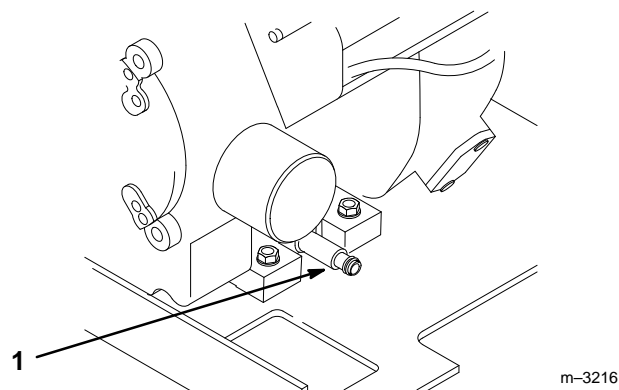

Figure 17

1. Oil drain valve

6. Remove the oil fill cap and slowly pour approximately 80% of the specified amount of oil in through the valve cover.
7. Check the oil level; refer to Checking Oil Level, page 14.
8. Slowly add additional oil to bring the oil level to the full mark on the dipstick.
9. Replace the fill cap.

PROTOTYPE

Changing the Oil Filter

Replace the oil filter every 200 hours or every other oil change.

Note: Change the oil filter more frequently when operating conditions are extremely dusty or sandy.

1. Drain the oil from the engine; refer to Changing/Draining Oil, page 27.
2. Remove the old filter and wipe the filter adapter (Fig. 18) gasket surface.
3. Apply a thin coat of new oil to the rubber gasket on the replacement filter (Fig. 18).

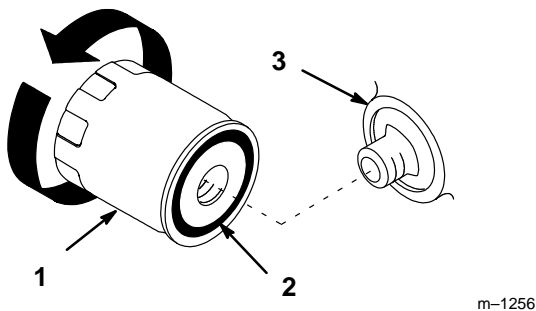

Figure 18

1. Oil filter
2. Gasket
3. Adapter

4. Install the replacement oil filter on the filter adapter. Turn the oil filter clockwise until the rubber gasket contacts the filter adapter, then tighten the filter an additional 1/2 turn (Fig. 18).
5. Fill the crankcase with the proper type of new oil; refer to Changing/Draining Oil, page 27.

Servicing the Spark Plugs

Check the spark plugs after every 200 operating hours. Ensure that the air gap between the center and side electrodes is correct before installing each spark plug. Use a spark plug wrench for removing and installing the spark plugs and a gapping tool/feeler gauge to check and adjust the air gap. Install new spark plugs if necessary.

Type: Champion RC12YC (or equivalent) Air Gap: 0.030 in. (0.76 mm)

Removing the Spark Plugs

1. Lower the loader arms, stop the engine, and remove the key.
2. Pull the wires off of the spark plugs (Fig. 19).
3. Clean around the spark plugs to prevent dirt from falling into the engine and potentially causing damage.
4. Remove the spark plugs and metal washers.

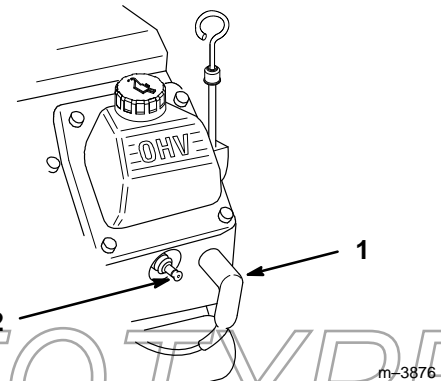

Figure 19

1. Spark plug wire
2. Spark plug

Checking the Spark Plugs

1. Look at the center of the spark plugs (Fig. 20). If you see light brown or gray on the insulator, the engine is operating properly. A black coating on the insulator usually means the air cleaner is dirty.

IMPORTANT: Replace the spark plugs when they have a black coating, worn electrodes, an oily film, or cracks. Do not attempt to clean a spark plug.

2. Check the gap between the center and side electrodes (Fig. 20). Bend the side electrode (Fig. 20) if the gap is not correct.

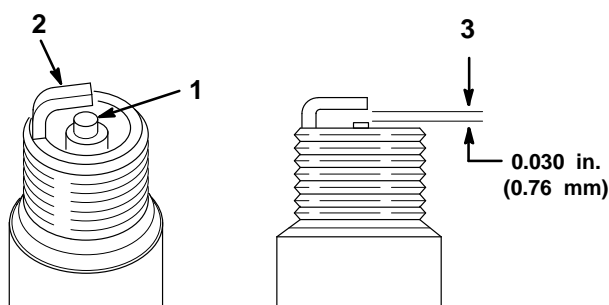

m-3215

Figure 20

- | | |
|-------------------------------|---------------------------|
| 1. Center electrode insulator | 3. Air gap (not to scale) |
| 2. Side electrode | |

Installing the Spark Plugs

1. Install the spark plugs.
2. Tighten the spark plugs to 20 ft-lb (27 N.m).
3. Push the wires onto the spark plugs (Fig. 19).

Greasing and Lubrication

Grease all pivot joints every 8 operating hours and immediately after every washing. Lubricate the drive chain every 50 operating hours.

Greasing the Traction Unit

Grease Type: General-purpose grease.

1. Lower the loader arms, stop the engine, and remove the key.
2. Clean the grease fittings with a rag.
3. Connect a grease gun to each fitting in turn.
4. Pump grease into the fittings until it begins to ooze out of the bearings.
5. Wipe up any excess grease.

Lubricating Traction Drive Chain

1. Lower the loader arms, stop the engine, and remove the key.
2. Apply a general purpose oil (10W30) onto upper and lower chain spans.
3. Start the traction unit and slowly move it forward to expose un-lubed upper and lower chain spans.
4. Stop the engine and remove the key.
5. Apply oil to newly exposed un-lubed chain spans.

PROTOTYPE

Replacing the Fuel Filter

Replace the fuel filter after every 200 operating hours or yearly, whichever occurs first.

Replacing the Fuel Filter

Do not re-install a dirty filter.

1. Lower the loader arms, stop the engine, and remove the key.
2. Shut off the fuel valve on the bottom of the fuel tank.
3. Clamp fuel line between fuel tank and fuel filter to block fuel flow.
4. Squeeze the ends of the hose clamps together and slide them away from the filter (Fig. 21).
5. Place a drain pan under the fuel lines to catch any leaks, then remove the filter from the fuel lines.
6. Install a new filter and move the hose clamps close to the filter.
7. Remove clamp blocking fuel flow and open the fuel valve.

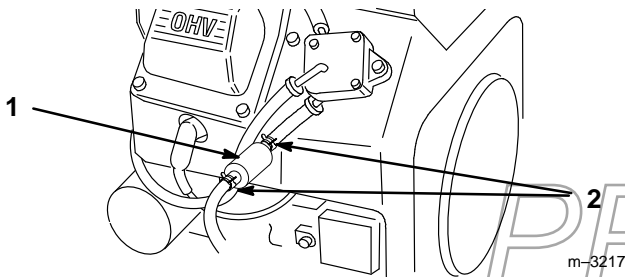

Figure 21

1. Filter
2. Hose clamp

Draining the Fuel Tank



POTENTIAL HAZARD

- In certain conditions gasoline is extremely flammable and highly explosive.

WHAT CAN HAPPEN

- A fire or explosion from gasoline can burn you, others, and cause property damage.

HOW TO AVOID THE HAZARD

- Drain gasoline from the fuel tank when the engine is cold. Do this outdoors in an open area. Wipe up any gasoline that spills.
- Never drain gasoline near an open flame or where gasoline fumes may be ignited by a spark.
- Never smoke while handling fuel.

1. Park the traction unit on a level surface, to ensure that fuel tank drains completely.
2. Lower the loader arms, stop the engine, and remove the key.
3. Shut off the fuel valve on the bottom of the fuel tank.
4. Loosen the hose clamp at the fuel filter and slide it up the fuel line away from the fuel filter.
5. Pull the fuel line off fuel filter, open the fuel valve, and allow gasoline to drain into a gas can or drain pan.

Note: Now is the best time to install a new fuel filter because the fuel tank is empty.

6. Install the fuel line onto the fuel filter. Slide the hose clamp close to the fuel filter to secure the fuel line.
7. Open the fuel valve on the bottom of the fuel tank.

Servicing the Hydraulic System

Replacing the Hydraulic Filter

Change the hydraulic filter:

- After the first 8 operating hours.
 - After every 200 operating hours.
1. Park the traction unit on a level surface, to ensure that fuel tank drains completely.
 2. Place drain pan under filter, remove the old filter, and wipe the filter adapter gasket surface clean.
 3. Apply a thin coat hydro fluid to the rubber gasket on the replacement filter (Fig. 22).
 4. Install a replacement hydraulic filter onto the filter adapter. Tighten it clockwise until the rubber gasket contacts the filter adapter, then tighten the filter an additional 1/2 turn (Fig. 22).

IMPORTANT: Do not substitute an automotive oil filter or severe hydraulic system damage may result.

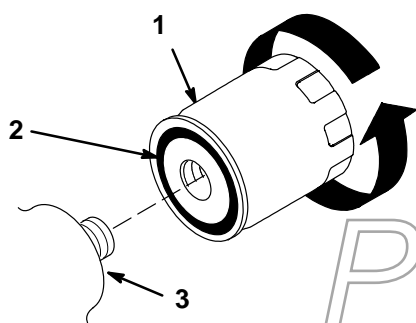

Figure 22

- | | |
|---------------------|------------|
| 1. Hydraulic filter | 3. Adapter |
| 2. Gasket | |

5. Clean up any spilled fluid.

6. Start the engine and let run for about two minutes to purge air from the system.
7. Stop the engine and check for leaks.
8. Check the fluid level in the hydraulic tank and add enough oil to raise the level to mark on dipstick.

Changing the Hydraulic Fluid

Change the hydraulic fluid:

- After the first 8 operating hours.
 - After every 400 operating hours.
1. Park the traction unit on a level surface.
 2. Place a large drain pan under the traction unit that can hold at least 17 gal. (67 l).
 3. Remove the drain plug from the bottom of the hydraulic tank and allow the fluid to completely drain out.
 4. Install the drain plug.
 5. Fill the hydraulic tank with approximately 15 gal. (57 L) of Toro Hy-Pro, Mobil Fluid 424, or equivalent (refer to Checking Hydraulic Fluid on page 15).

IMPORTANT: Do not substitute automotive oil or severe hydraulic system damage may result.

Note: Dispose of used oil at a certified recycling center.

Checking Hydraulic Lines

After every 100 operating hours, check the hydraulic lines and hoses for leaks, loose fittings, kinked lines, loose mounting supports, wear, weather and chemical deterioration. Replace all moving hydraulic hoses every 1500 hours or 2 years, whichever comes first. Make necessary repairs before operating.

! WARNING

POTENTIAL HAZARD

- Hydraulic fluid escaping under pressure can penetrate skin and cause injury.

WHAT CAN HAPPEN

- Fluid accidentally injected into the skin must be surgically removed within a few hours by a doctor familiar with this form of injury or gangrene may result.

HOW TO AVOID THE HAZARD

- Keep body and hands away from pin hole leaks or nozzles that eject high pressure hydraulic fluid.
- Use cardboard or paper to find hydraulic leaks, never use your hands.

Servicing the Traction Drive Chains

Checking the Tension

Check the drive chain tension before using the traction unit for the first time and every 50 hours of use thereafter.

The drive chains should have about 1-1/2 to 2-1/2 inches (3.8 to 6.35 cm) of slack between the bottom of the chain guard and the bottom chain span when the top chain span is pulled tight. Use the following procedure to check the tension:

1. With the bucket installed, lower it into the ground until the front tires are off of the ground.
2. Stop the engine and remove the key.

3. Turn the front wheel forward on one side of the traction unit until the top span of the drive chain is tight.
4. Measure the distance between the bottom of the chain guard and the lower chain span (Fig. 23). If the slack in the chain is not within 1-1/2 to 2-1/2 inches (3.8 to 6.35 cm), adjust the tension (refer to Adjusting the Tension).

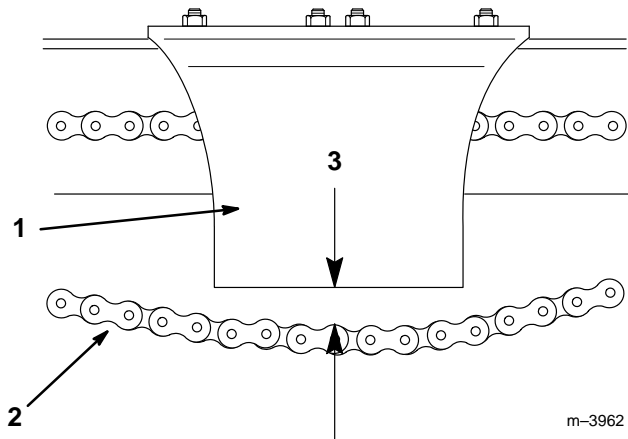

Figure 23

1. Chain guard
2. Bottom span of the chain
3. 1-1/2" to 2-1/2"

5. Repeat steps 3 and 4 for the other drive chain.
6. Start the engine and raise the bucket to return the front wheels to the ground.

Adjusting the Tension

1. With the bucket installed, lower it into the ground until the front tires are off of the ground.
2. Stop the engine and remove the key.
3. Loosen the nuts securing the axle retaining bracket (Fig. 24).

- Loosen the jam nut on the chain tensioning bolt and loosen the bolt (Fig. 24).

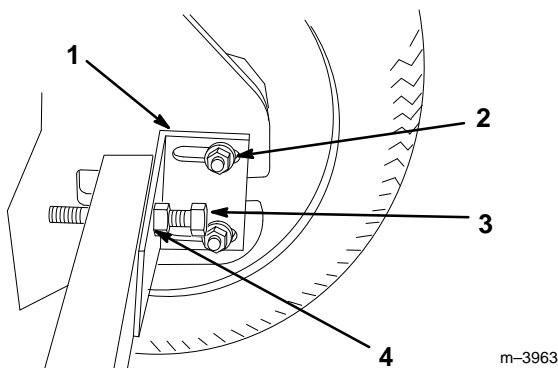

Figure 24

- | | |
|---------------------------|--------------------------|
| 1. Axle retaining bracket | 3. Chain tensioning bolt |
| 2. Nut | 4. Jam nut |

- Turn the front wheel on one side of the traction unit until the upper span of the drive chain is tight.
- Adjust the chain tensioning bolt until the distance between the bottom of the chain guard and the lower chain span is within 1-1/2 to 2-1/2 inches (3.8 to 6.35 cm) (Fig. 23).
- Position the axle retaining bracket tight against the axle and the frame, then tighten the jam nut on the bolt to secure it in place (Fig. 24) and torque the nut to 30 ft-lbs (40.7 N·m).
- Tighten the nuts securing the axle retaining bracket and torque them to 90 ft-lbs (122 N·m).
- Repeat steps 3 through 8 for the other drive chain.
- Start the engine and raise the bucket to return the front wheels to the ground.

Servicing the Battery

Check the electrolyte level in the battery every 100 hours. Always keep the battery clean and fully charged. Use a paper towel to clean the battery case. If the battery terminals are corroded, clean them with

a solution of four parts water and one part baking soda. Apply a light coating of grease to the battery terminals to reduce corrosion.

Voltage: 12 v, 380 Cold Cranking Amps

Checking the Electrolyte Level

- Clean the top of the battery with a paper towel.
- Lift off the filler caps (Fig. 25).
- Check the electrolyte level. The electrolyte should be up to the lower part of the tube (Fig. 25). Do not allow the electrolyte to get below the top of the plates (Fig. 25).
- If the electrolyte is low, add distilled water to each cell until the level is up to the lower part of the tube (Fig. 25).

IMPORTANT: Do not overfill the battery because electrolyte (sulfuric acid) can cause severe corrosion and damage to the chassis.

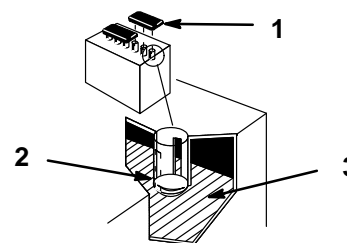

Figure 25

- | | |
|-----------------------|-----------|
| 1. Filler caps | 3. Plates |
| 2. Lower part of tube | |

- Press the filler caps onto the battery.

Charging the Battery

IMPORTANT: Keep the battery fully charged (1.260 specific gravity). This is especially important to prevent battery damage when the temperature is below 32°F (0°C).

- Check the electrolyte level; refer to Checking Electrolyte Level, page 33.

2. Remove the filler caps from the battery and connect a 3 to 4 amp battery charger to the battery posts.
3. Charge the battery at a rate of 4 amperes or less for 4 hours (12 volts). Do not overcharge the battery.

 **WARNING**

POTENTIAL HAZARD

- **Charging the battery produces gasses.**

WHAT CAN HAPPEN

- **Battery gasses can explode.**

HOW TO AVOID THE HAZARD

- **Keep cigarettes, sparks and flames away from battery.**

4. Install the filler caps after the battery is fully charged.

Cleaning and Storage

1. Lower the loader arms, stop the engine, and remove the key.
2. Remove dirt and grime from the external parts of the entire traction unit, especially the engine. Clean dirt and chaff from the outside of the engine's cylinder head fins and blower housing.

IMPORTANT: You can wash the traction unit with mild detergent and water. Do not pressure wash the traction unit. Avoid excessive use of water, especially near the control panel, engine, hydraulic pumps and motors.

3. Service the air cleaner; refer to Servicing the Air Cleaner, page 25.
4. Grease the traction unit; refer to Greasing and Lubrication, page 29.
5. Change the engine oil; refer to Servicing the Engine Oil, page 26.
6. Remove the spark plugs and check their condition; refer to Servicing the Spark Plugs, page 28.
7. With the spark plugs removed from the engine, pour two tablespoons of engine oil into the spark plug holes.
8. Use the starter to crank the engine and distribute the oil inside the cylinder.
9. Install the spark plugs, but do not install the wires on the spark plugs.
10. Check the tire pressure; refer to Tire Pressure, page 16.
11. Charge the battery; refer to Servicing the Battery page 33.
12. For storage over 30 days, prepare the traction unit as follows.
 - A. Add a petroleum based stabilizer/conditioner to fuel in the tank. Follow mixing instructions from stabilizer manufacturer. (1 oz. per gallon). **Do not use an alcohol based stabilizer (ethanol or methanol).**

Note: A fuel stabilizer/conditioner is most effective when mixed with fresh gasoline and used at all times.

- B. Run the engine to distribute conditioned fuel through the fuel system (5 minutes).
- C. Stop the engine, allow it to cool and drain the fuel tank; refer to Draining Fuel Tank, page 30.
- D. Restart the engine and run it until it stops.
- E. Choke the engine.
- F. Start and run the engine until it will not start again.
- G. Dispose of fuel properly. Recycle as per local codes.

IMPORTANT: Do not store stabilizer/conditioned gasoline over 90 days.

- 13. Check and tighten all bolts, nuts, and screws. Repair or replace any part that is damaged or missing.
- 14. Paint all scratched or bare metal surfaces. Paint is available from your Authorized Service Dealer.
- 15. Store the traction unit in a clean, dry garage or storage area. Remove the key from the ignition switch and keep it in a memorable place. Cover the traction unit to protect it and keep it clean.

PROTOTYPE

Troubleshooting

PROBLEM	POSSIBLE CAUSES	CORRECTIVE ACTION
Starter does not crank	<ol style="list-style-type: none"> 1. Auxiliary hydraulics lever is not in neutral position. 2. Battery is dead. 3. Electrical connections are corroded or loose. 4. Relay or switch is defective. 	<ol style="list-style-type: none"> 1. Move lever to neutral position. 2. Charge the battery. 3. Check electrical connections for good contact. 4. Contact Authorized Service Dealer.
Engine will not start, starts hard, or fails to keep running.	<ol style="list-style-type: none"> 1. Fuel tank is empty. 2. Choke is not ON. 3. Air cleaner is dirty. 4. Spark plug wires is loose or disconnected. 5. Spark plugs are pitted, fouled, or gap is incorrect. 6. Dirt in fuel filter. 7. Dirt, water, or stale fuel is in fuel system. 	<ol style="list-style-type: none"> 1. Fill fuel tank with gasoline. 2. Move choke lever to ON. 3. Clean or replace air cleaner element. 4. Install wires on spark plug. 5. Install new, correctly gapped spark plugs. 6. Replace fuel filter. 7. Contact Authorized Service Dealer.
Engine loses power.	<ol style="list-style-type: none"> 1. Engine load is excessive. 2. Air cleaner is dirty. 3. Oil level in crankcase is low. 4. Cooling fins and air passages under engine blower housing are plugged. 5. Spark plugs are pitted, fouled, or gap is incorrect. 6. Dirt in fuel filter. 7. Dirt, water, or stale fuel is in fuel system. 	<ol style="list-style-type: none"> 1. Reduce ground speed. 2. Clean air cleaner element. 3. Add oil to crankcase. 4. Remove obstruction from cooling fins and air passages. 5. Install new, correctly gapped spark plugs. 6. Replace fuel filter. 7. Contact Authorized Service Dealer.
Engine overheats.	<ol style="list-style-type: none"> 1. Engine load is excessive. 2. Oil level in crankcase is low. 3. Cooling fins and air passages under engine blower housing are plugged. 	<ol style="list-style-type: none"> 1. Reduce ground speed. 2. Add oil to crankcase. 3. Remove obstruction from cooling fins and air passages.
Abnormal vibration.	<ol style="list-style-type: none"> 1. Engine mounting bolts are loose. 	<ol style="list-style-type: none"> 1. Tighten engine mounting bolts.

PROBLEM	POSSIBLE CAUSES	CORRECTIVE ACTION
Machine does not drive.	<ol style="list-style-type: none"> 1. Flow divider valve lever is in 9 o'clock position. 2. Hydro fluid level low. 3. Traction pump drive coupler is loose or broken. 4. Pump and/or wheel motor is defective or damaged. 5. Control valve is defective or damaged. 6. Relief valve is defective or damaged. 	<ol style="list-style-type: none"> 1. Move lever to the 12 to 10 o'clock position. 2. Add hydro fluid to reservoir. 3. Contact Service Dealer. 4. Contact Service Dealer. 5. Contact Service Dealer. 6. Contact Service Dealer.
When at rest, loader arms creep downward more than 3" per hour (less than 3" an hour is normal for this machine).*	<ol style="list-style-type: none"> 1. Valve spool leakage 	<ol style="list-style-type: none"> 1. Contact Service Dealer.
When at rest, loader arms settle downward 2" quickly and then stop.*	<ol style="list-style-type: none"> 1. Cylinder seals are leaking 2. Cylinder rephase valve is leaking 	<ol style="list-style-type: none"> 1. Replace seals. 2. Contact Service Dealer.

* Tested with warm oil and no more than 515 lbs in the bucket. Measure the downward drop at the attachment lock pins on the back of the mount plate.

PROTOTYPE

The Toro SiteWork™ Systems Product Line

One Year Limited Warranty

The Toro Company warrants your Toro SiteWork™ Systems Product ("Product") to be free from defects in materials or workmanship for the period of time listed below. Where a warrantable condition exists, Toro will repair the Product at no cost to you including diagnosis, labor, parts, and transportation. This warranty begins on the date the Product is delivered to the original retail purchaser.

Warranty Duration: One year or 500 operational hours, whichever occurs first.

Owner Responsibilities:

As the Product owner, you are responsible for required maintenance and adjustments stated in your Owner's Manual. Failure to perform required maintenance and adjustments can be grounds for disallowing a warranty claim.

Instructions for Obtaining Warranty Service:

You are responsible for notifying the Toro SiteWork Systems Distributor or Authorized Toro SiteWork™ Systems Dealer from whom you purchased the Product as soon as you believe a warrantable condition exists.

If you need help locating a Toro SiteWork™ Systems Distributor or Authorized Dealer, or if you have questions regarding your warranty rights or responsibilities, you may contact us at:

Toro LCE Division
8111 Lyndale Avenue South
Minneapolis, MN, 55420-1196
Telephone: (612) 888-8801
Facsimile: (612) 887-8258

Maintenance Parts:

Parts scheduled for replacement as required maintenance ("Maintenance Parts"), are warranted for the period of time up to the scheduled replacement time for that part.

Items/Conditions Not Covered:

Not all product failures or malfunctions that occur during the warranty period are defects in materials or workmanship. The items / conditions listed below are not covered by this warranty:

- Product failures which result from the use of non-Toro replacement parts, or from installation and use of add-on, modified, or unapproved accessories are not covered.
- Product failures which result from failure to perform required maintenance and/or adjustments are not covered.
- Product failures which result from operating the Product in an abusive, negligent or reckless manner are not covered.

- This warranty does not apply to parts subject to consumption through use unless found to be defective. Examples of parts which are consumed, or used up, during normal Product operation include, but are not limited to, digging teeth, tines, spark plugs, tires, filters, chains, etc.
- This warranty does not apply to failures caused by outside influence. Items considered to be outside influence include, but are not limited to, weather, storage practices, contamination, use of unapproved coolants, lubricants, additives, or chemicals, etc.
- This warranty does not apply to normal "wear and tear" items. Normal "Wear and Tear" includes, but is not limited to, worn painted surfaces, scratched decals or windows, etc.

Other Legal Disclaimers:

The above remedy of product defects through repair by an authorized distributor or dealer is the purchaser's sole remedy for any defect. This warranty gives you specific legal rights, and you may also have other rights which vary from state to state.

Except for the Emissions warranty referenced below, if applicable, there is no other express warranty. All implied warranties of merchantability and fitness for use are limited to the duration of the express warranty.

Some states do not allow limitations on how long an implied warranty lasts, so the above limitation may not apply to you.

The Toro Company is not liable for indirect, incidental or consequential damages in connection with the use of the Product, including any cost or expense of providing substitute Product or service during periods of malfunction or non-use.

Some states do not allow the exclusion of incidental or consequential damages, so the above exclusion may not apply to you.

Note to California residents: The Emissions Control System on your Product may be covered by a separate warranty meeting requirements established by the U.S. Environmental Protection Agency (EPA), or the California Air Resources Board (CARB). The hour limitations set forth above do not apply to the Emissions Control System Warranty. Refer to the California Emission Control Warranty Statement printed in your Owner's Manual or contained in the engine manufacturer's documentation for details.