

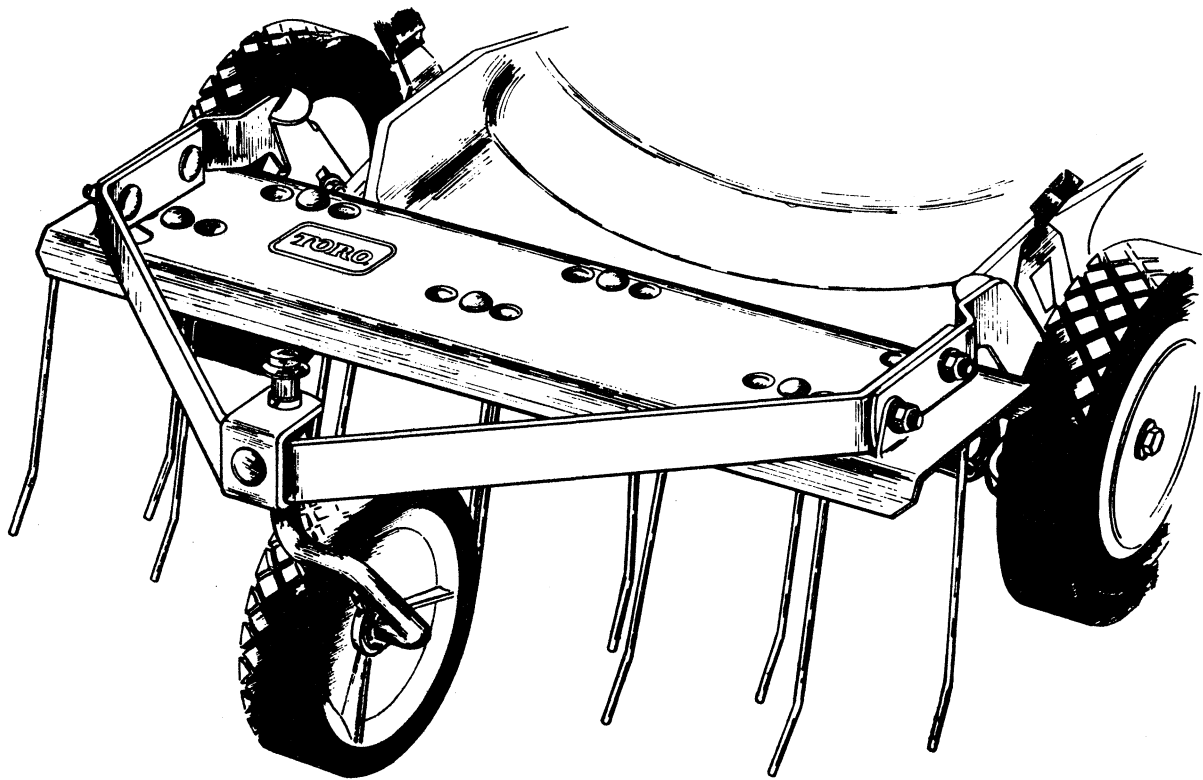

MODEL: 59128

**OPERATOR'S
MANUAL**

21" (0.53m) FRONT MOUNT THATCHER



INTRODUCTION

Thank you for purchasing this quality product! The regular removal of thatch is critical to the maintenance of a healthy lawn. Your thatcher will effectively dislodge excessive thatch from your lawn. Thatch is a layer of stems, clippings, runners, roots and leaves that have not decayed. Excessive thatch prevents air, water, and fertilizer from reaching the roots.

When correctly assembled and adjusted, and with proper care, your thatcher will provide years of trouble-free lawn maintenance.

NOTE: It is recommended that you carefully read this Owner's Manual BEFORE starting assembly of your thatcher.

Arrange EACH kind of hardware into a group to ease assembly. NOTE: Lock nuts must be used where specified. They have a slightly oblong hole or a fiber insert and are domed on one end.

Tools required for assembly:

- 1 - screwdriver (flat)
 - 1 - pair of pliers (slip-joint recommended)
 - 1 - hammer
 - 1 - 7/16" wrench
 - 1 - 1/2" wrench
 - 1 - 9/16" wrench
 - 1 - 1/2" socket
 - 1 - 9/16" socket
 - 1 - 3/4" socket
 - 1 - socket wrench handle
 - 1 - medium size adjustable wrench (optional)
-

NOTE: Reference to RIGHT SIDE and LEFT SIDE is made while standing in the operator's position — behind the thatcher (or the mower).



WARNING! Carefully read and follow safety information (cautions and warnings) in this manual and the Operator's Manual which came with your mower to prevent injury or damage.

(A) Operate your thatcher only when there is adequate light.

(B) Remove all debris such as wire, bottles, cans, sticks, and stones from the area to be dethatched.

(C) Always remove the spark plug cable and disconnect battery on electric start mower before servicing your mower thatcher.

(D) Before each use check to make sure all fasteners are tight, tines are functioning properly, and safety wires are in place.

(E) Reduce speed and cautiously dethatch any area (rough ground) of the turf that may have hidden hazards.

(F) Do not leave your mower running while unattended - stop the engine and remove the ignition key if so equipped.

(G) Make a visual check of the thatcher stop bracket — it must be in the proper location and tight!

(H) Store thatcher on the floor to prevent any injuries from occurring.

FIG. 1. Install the 6 tines (4) to the tine tray (9) by laying the tray on a flat surface with the flanges facing UP. Next, nest each tine loop between the embossed "dimples" with bent tips facing forward - toward tab cutouts "A" and secure with one 5/16" x 3/4" carriage bolt (25), a special washer (3), one 5/16" lock washer (28), and a 5/16" hex nut (27). Tighten securely. Install both safety wires (12) through the tine coils and bend ends over to secure (use pliers.)

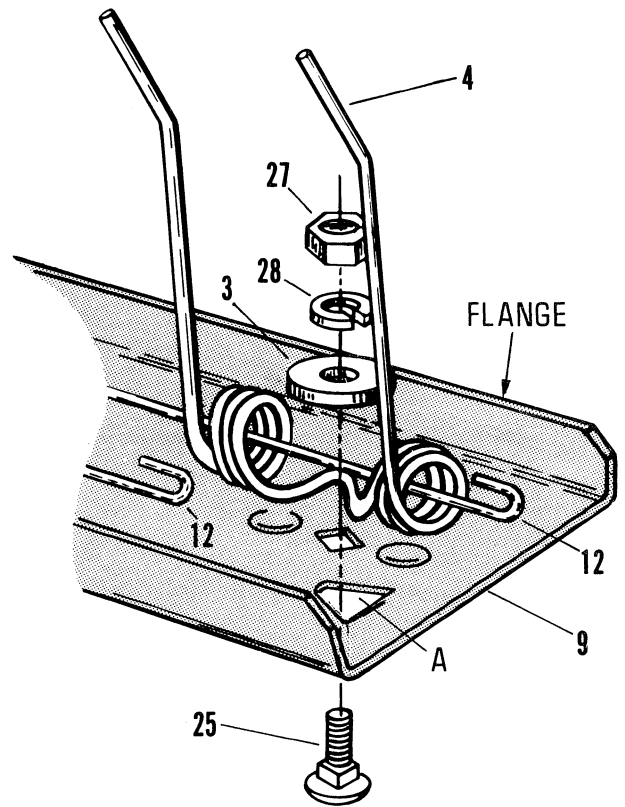
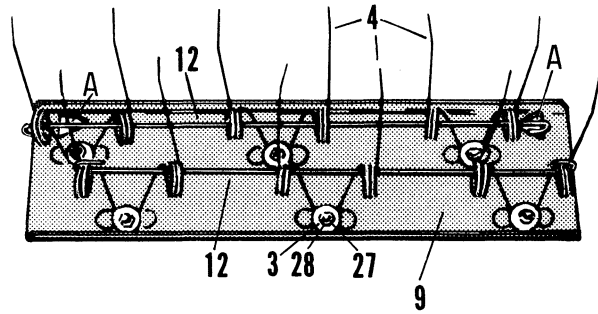

WARNING! Failure to install safety wires can result in personal injury if a tine should disengage from the tine tray.

FIG. 2. Turn the tine tray right side up and install the frame bar (11), right hand mount bar (19), and left hand mount bar (20) to the inside of tabs "A" with offsets toward each other. Insert one 5/16" x 1" carriage bolt (26) FACING OUTWARD through the FRONT square hole in the left side of frame bar (11), then the FRONT square hole in the left hand mount bar (20) and then through the round hole in the left tab "A" on the tine tray; secure with one 5/16" lock washer (28) and a 5/16" hex nut (27) - follow the same procedure for the right side.

Install a 5/16" x 3/4" carriage bolt (25) FACING OUTWARD through the rear square hole in the right hand and the left hand side of the frame bar and secure with 5/16" lock washers (28) and 5/16" hex nuts (27). Tighten these fasteners securely.

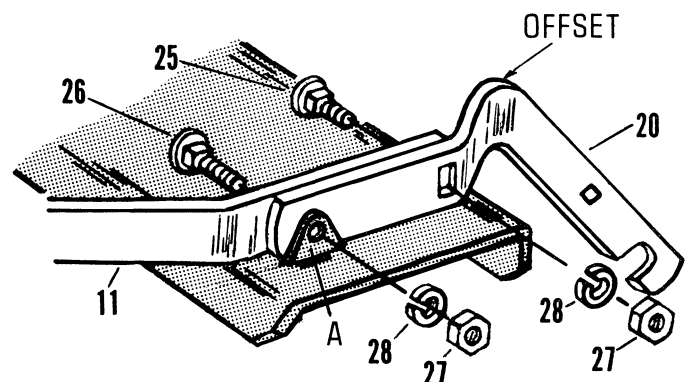
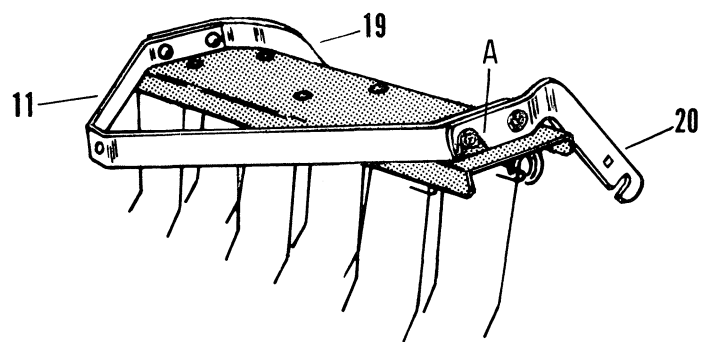

FIG. 3. Assemble the wheel mount bracket (16) to the frame bar (11) with one 5/16" x 3/4" carriage bolt (25) inserted through the square hole and secured with one 5/16" lock washer (28), and one 5/16" hex nut (27) - on the inside of the frame bar. Tighten securely.

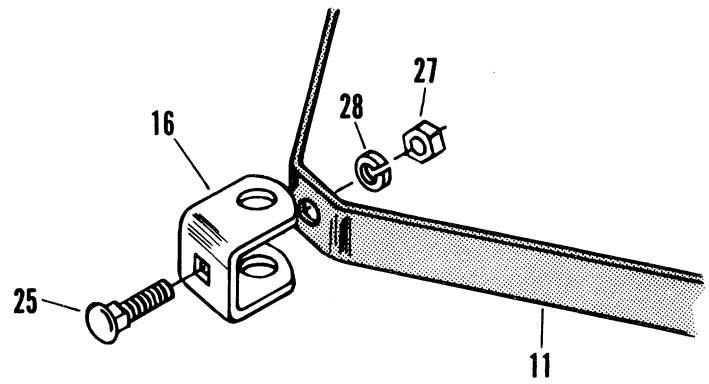

FIG. 4. Place one latch (14) against the inside of each mount bar with the tab up (and facing inward) and the long slot located in front of the square hole near the mounting slot. Secure each latch with one 1/4" x 3/4" carriage bolt (24) - facing inward, a special washer (18), "O" ring (2), special washer (18) and 1/4" hex lock nut (1) Tighten both lock nuts until there is SOME friction when sliding the latches against the mount bars - do not overtighten!

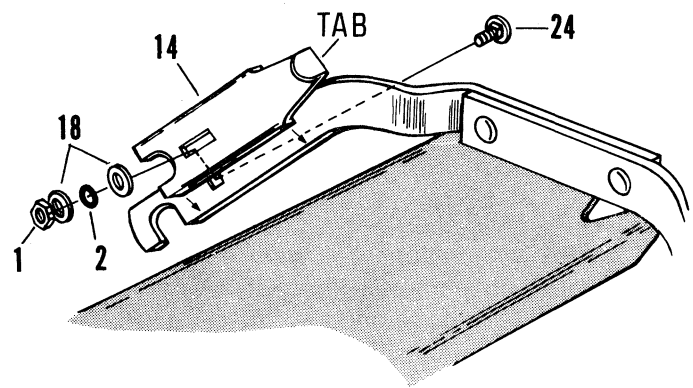
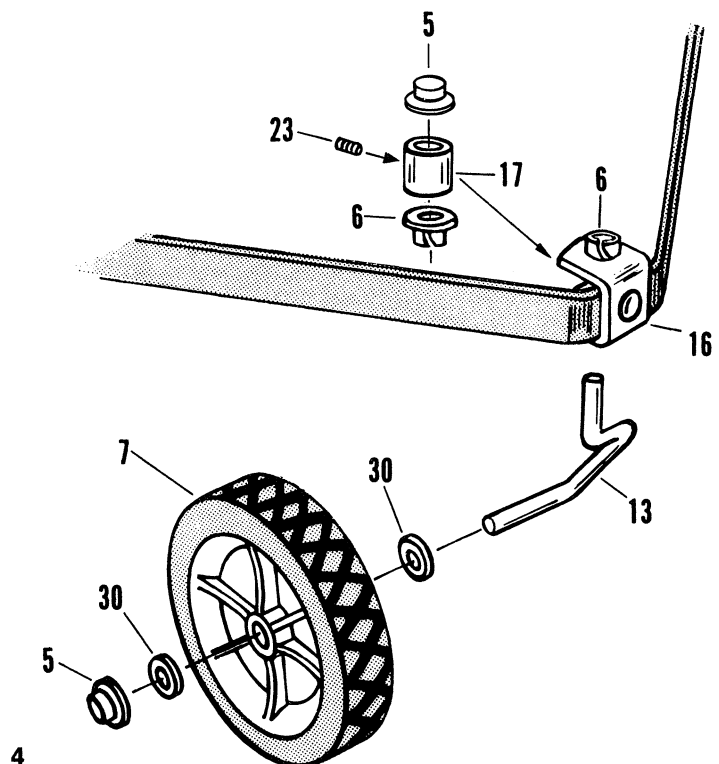

FIG. 5. Assemble the gauge wheel (7) and axle (13) to the wheel mount bracket (16) as follows: slide one 1/2" I.D. flat washer (30) on to the short end of axle (13), followed by the gauge wheel (7) with hub facing out, and another 1/2" flat washer (30) and then "tap" the push nut (5) on the shaft with a hammer.

Next, insert the two 1/2" I.D. nylon bearings (6) in the round holes (from inside) in wheel mount bracket (16) with the flange surface on each bearing facing inward. Position the axle bushing (17) between the flange surfaces of bearings and slide the long end of wheel axle up through the bracket, bearings, and the bushing, then secure with 5/16"x1/4" set screw (23). Finally, "tap" the remaining push nut (5) down on the end of the axle (13) with a hammer.



MOWER PREPARATION/ THATCHER INSTALLATION



WARNING: AVOID ACCIDENTAL START-UP. REMOVE THE SPARK PLUG CABLE AND DISCONNECT THE BATTERY ON ELECTRIC START MOWERS.

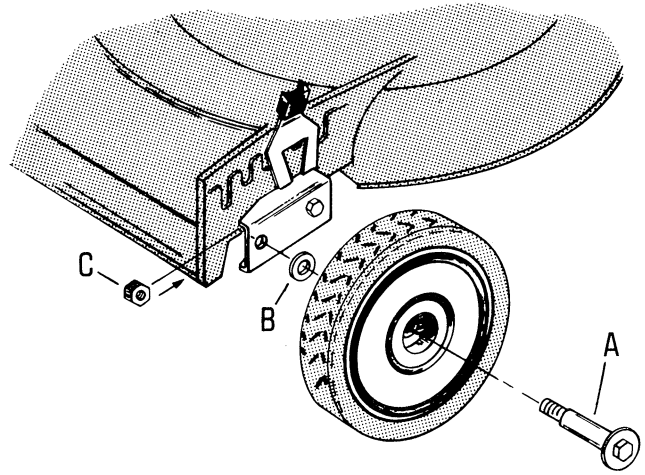

FIG. 6. Remove the large shoulder bolt (A) and thin washer (B) from the left FRONT wheel of mower. (they will not be reused). Save the lock nut (C) — it will be reused.

Repeat this procedure on the right side.

FIG. 7. Re-install the LEFT mower wheel as follows:

First, slip one 1/2" flat washer (30) on one new shoulder bolt (21) and slip the bolt through the hole in mower wheel (from "outside" surface of wheel). Next, slip on a 3/8" flat washer (29) and frame spacer (15). Insert the shoulder bolt through the hole in the mounting bracket (D) and install the stop bracket (22) on bolt BEHIND mounting bracket (D). Secure this assembly with the reuseable mower lock nut (C). Tighten securely!

NOTE: Install the stop bracket (22) with the "Crescent" shaped cutout facing up and the stop "TAB" facing outward - the stop bracket is used only on the left side.

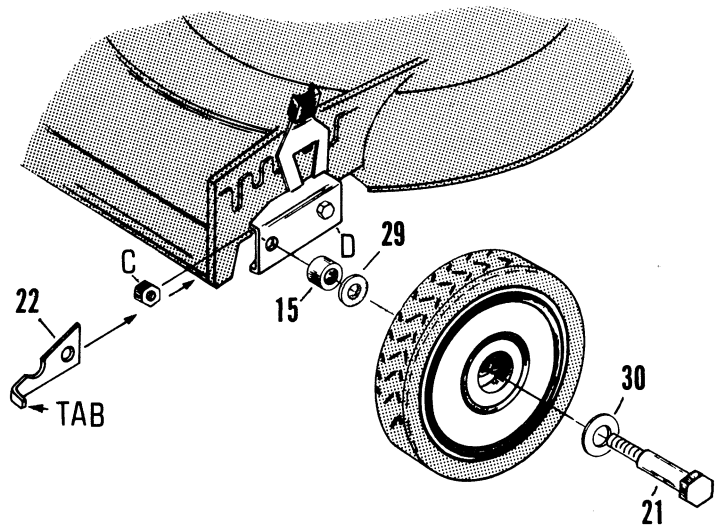

Repeat this procedure for the right side.



CAUTION: The thatcher stop bracket must be installed to prevent the thatcher from swinging into the mower blade when the front wheels are raised off the ground. Thatcher contact with the mower blade can result in a thrown object (equipment damage) and bodily injury.

FIG. 8. Install your thatcher by sliding both latches (14) up to clear the mounting slots on the mount bars. Then position the front wheel adjustments on your mower to the lowest cutting height and place the mounting slots over the frame spacers. Then, slide the latches downward locking the thatcher to the mower. Check all fasteners for tightness.

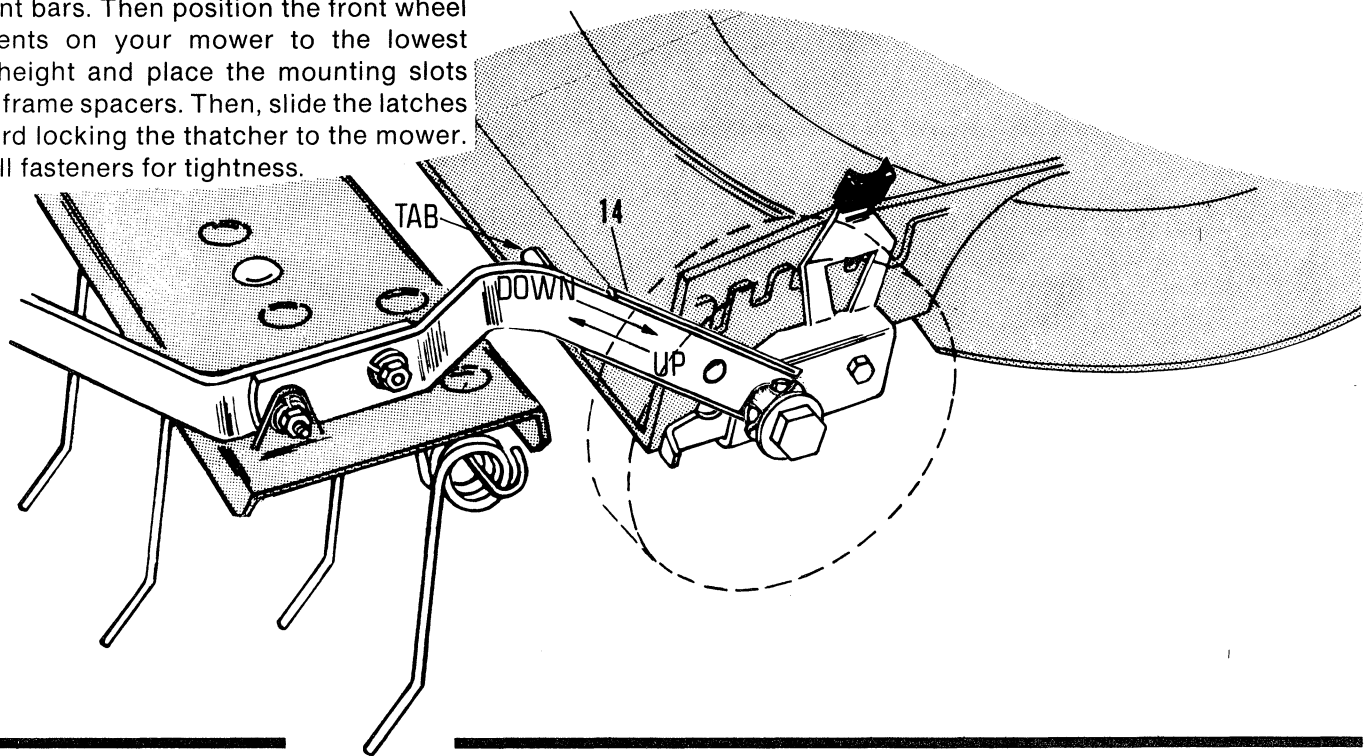

ADJUSTMENT

FIG. 9 With the thatcher mounted to your mower, position both units over a smooth flat surface such as a sidewalk, driveway or garage floor. Adjust the mower height (check your Owner's Manual for correct procedures) to 3 inches or less and with the gauge wheel directly under the wheel mount bracket (16), loosen the set screw (23) in axle bushing (17) and adjust the frame bar (11) until the tine tips are approximately 1/2" above the flat surface in the "free" position, and touch the surface when deflected rearward. Now tighten the set screw (23).

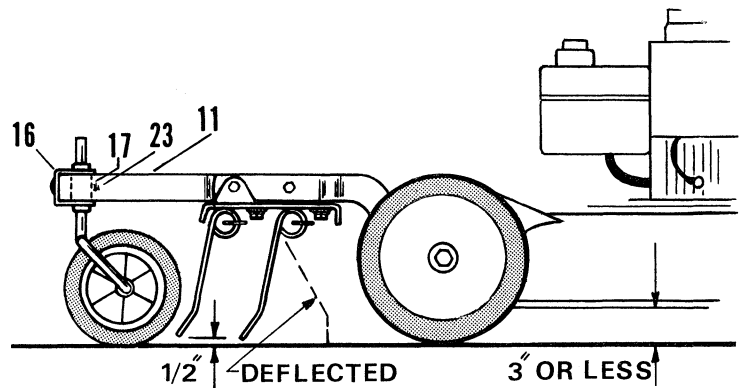

NOTE: The thatcher and mower heights can be adjusted independently of each other.

OPERATION

When dethatching, an overlap or cross hatch pattern is recommended. While all lawns are different, the ideal amount of thatch left on the lawn would be about 1/8" thick. Very dense lawns generally require more frequent dethatching than do less dense lawns.

Grass should be less than 3 inches tall for proper tine action. The tines should deflect back and then independently "flip" the thatch up and forward. If the tines tend to drag, raise them a little and again check the "flipping" action. Adjust the tine tray up or down as necessary for proper action.

MAINTENANCE

Before each use check all fasteners for tightness. Replace any missing fasteners before using.

Replace any worn or broken parts (including tines). Lubricate all pivot points and keep the thatcher stored in a dry location with the tines resting on the ground. Although the thatcher is generally a maintenance free steel product, it can rust. To prevent or eliminate rust on tines, apply a thin coat of oil. For rust on the tray, mount bars, or frame bar, sand the area lightly and apply a coat of enamel.

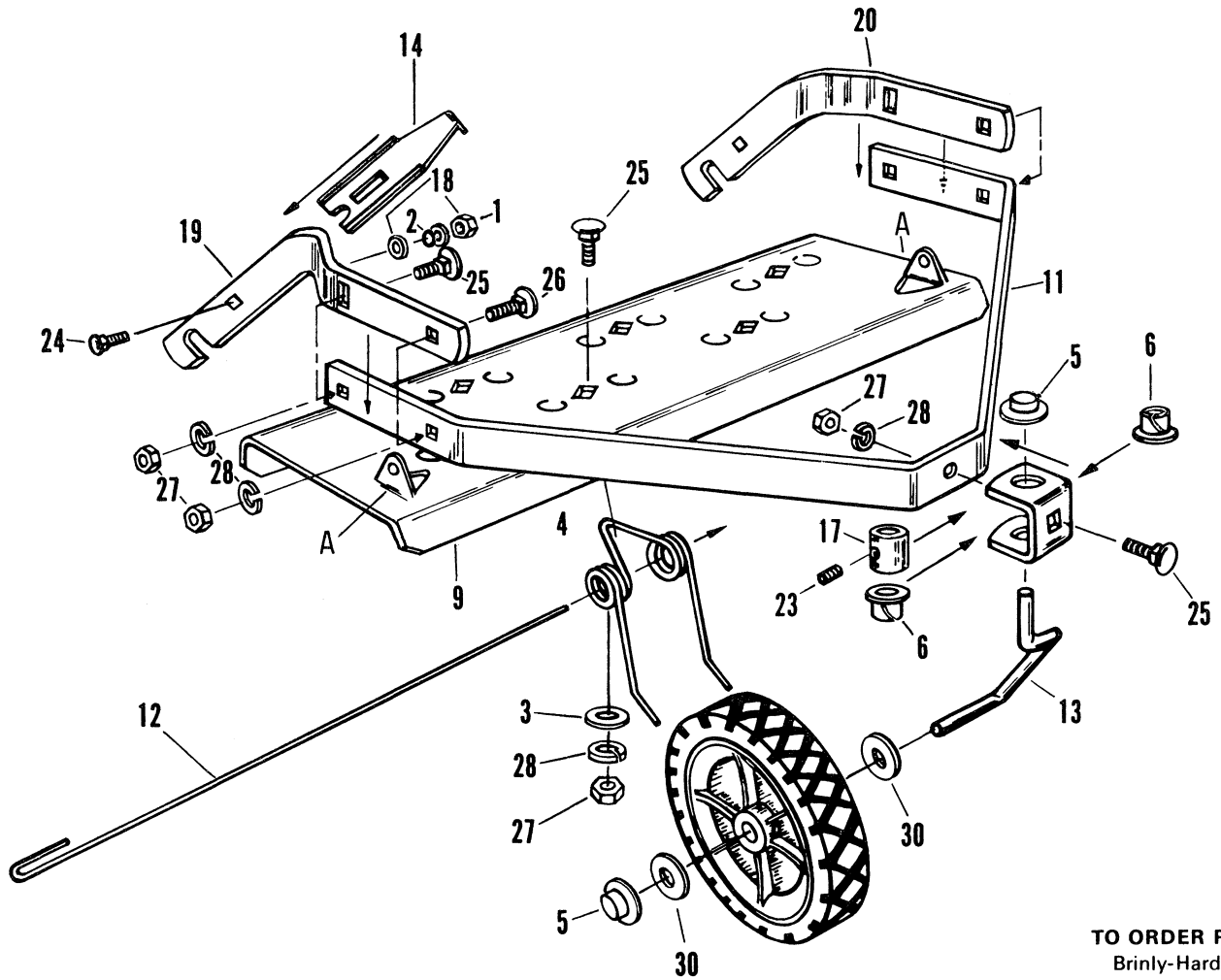

TO ORDER PARTS:
 Brinly-Hardy Co.
 P. O. Box 1116
 Louisville, Ky. 40201
 (502) 585-3351

PARTS LIST

Ref. No.	Part No.	Description
1	B-1673P	1/4" Hex Lock Nut
2	F-313	"O" Ring
3	R-618	Special Washer
4	R-628	Tine
5	R-636	Push Nut
6	R-704	1/2" I.D. Nylon Bearing
7	R-825	Gauge Wheel
8	R-1114	Logo Decal
9	R-1132-72	Tine Tray
10	R-1134	Caution Decal
11	R-1136-72	Frame Bar
12	R-1137	Safety Wire
13	R-1138-01	Axle
14	R-1140-01	Latch
15	R-1141	Frame Spacer
16	R-1142-72	Wheel Mount Bracket
17	R-1144-01	Axle Bushing
18	R-1145	Special Washer
19	R-1197-72	Mount Bar (R.H.)
20	R-1198-72	Mount Bar (L.H.)
21	R-1416	Shoulder Bolt
22	R-1417-01	Stop Bracket
23	V-336	5/16" x 1/4" Set Screw
24	10M0812P	1/4" x 3/4" Carriage Bolt
25	10M1012P	5/16" x 3/4" Carriage Bolt
26	11M1016P	5/16" x 1" Carriage Bolt
27	30M1000P	5/16" Hex Nut
28	40M1000P	5/16" Lock Washer
29	45M1313P	3/8" Flat Washer
30	45M1717P	1/2" Flat Washer

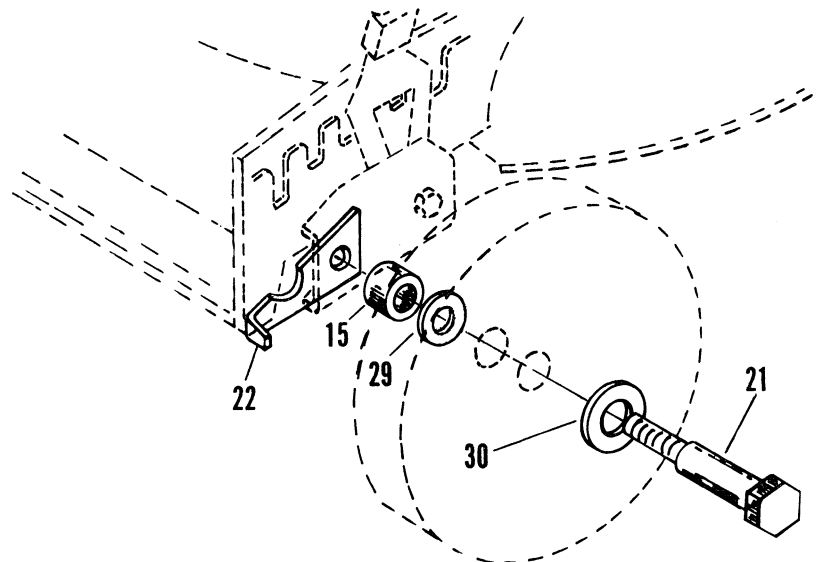

The Toro Promise

*A Two Year Limited Warranty
On All
Gasoline Powered Consumer Products*

The Toro Company promises to repair these TORO Products if defective in materials or workmanship. The following time periods from the date of purchase apply:

Residential Product 2 Years
Residential Products Used Commercially . . . 45 Days

The costs of parts and labor are included, but the customer pays the transportation costs. Just return any residential product to an Authorized TORO Service Dealer or TORO Distributor.

Should you feel your TORO is defective and wish to rely on The Toro Promise, the following procedure is recommended:

1. Contact any Authorized TORO Service Dealer, TORO Master Service Dealer, or TORO Distributor (the Yellow Pages of your telephone directory is a good reference source).
2. He will either instruct you to return the product to him or recommend another Authorized TORO Service outlet which might be more convenient.
3. Bring the product along with your original sales slip, or other evidence of purchase date, to the service dealer.
4. The servicing dealer will inspect the unit, advise you whether the product is defective and, if so, make all repairs necessary to correct the defect without extra charge to you.

If for any reason you are dissatisfied with the dealer's analysis of the defect or the service performed, you may contact us.

Write:

TORO Customer Service Department
8111 Lyndale Avenue South
Minneapolis, Minnesota 55420

The above remedy of product defects through repair by an Authorized TORO Service Dealer is the purchaser's sole remedy for any defect.

THERE IS NO OTHER EXPRESS WARRANTY. ALL IMPLIED WARRANTIES OF MERCHANTABILITY AND FITNESS FOR USE ARE LIMITED TO THE DURATION OF THE EXPRESS WARRANTY.

Some states do not allow limitations on how long implied warranty lasts, so the above limitation may not apply to you.

This Warranty applies only to parts or components which are defective and does not cover repairs necessary due to normal wear, misuse, accidents, or lack of proper maintenance. Regular, routine maintenance of the unit to keep it in proper operating condition is the responsibility of the owner.

All warranty repairs reimbursable under The Toro Promise must be performed by an Authorized TORO Service Dealer using Toro approved replacement parts.

Repairs or attempted repairs by anyone other than an Authorized TORO Service Account are not reimbursable under The Toro Promise. In addition, these unauthorized repair attempts may result in additional malfunctions, the correction of which is not covered by warranty.

The Toro Company is not liable for indirect, incidental or consequential damages in connection with the use of the product including any cost or expense of providing substitute equipment or service during periods of malfunction or non-use.

Some states do not allow the exclusion of incidental or consequential damages, so the above exclusion may not apply to you.

This warranty gives you specific legal rights, and you may also have other rights which vary from state to state.

COUNTRIES OTHER THAN THE UNITED STATES OR CANADA

Customers who have purchased TORO products exported from the United States or Canada should contact their TORO Distributor (Dealer) to obtain guarantee policies for your country, province or state. If for any reason

you are dissatisfied with your Distributor's service or have difficulty obtaining guarantee information, contact the TORO importer. If all other remedies fail, you may contact us at The Toro Company.

Compliance with Radio Interference Regulations Certified.
Certifie Conforme au Reglement sur le Brouillage Radioelectrique.