



MODELS 30753 — 80001 & UP

OPERATOR'S MANUAL

52" CUTTING UNIT FOR GROUNDMASTER® 117

The GROUNDMASTER 117 conforms to the American National Standards Institute's safety standards for riding mowers; thus, Toro proudly displays these ANSI safety seals.



To assure maximum safety, optimum performance, and to gain knowledge of the product, it is essential that you or any other operator of the mower read and understand the contents of this manual before the engine is ever started. Pay particular attention to the SAFETY INSTRUCTIONS highlighted by this symbol —



The safety alert symbol means CAUTION, WARNING or DANGER — personal safety instruction. Failure to comply with the instruction may result in personal injury.



FOREWORD

The 52" cutting deck has advanced concepts in engineering, design and safety; and if maintained properly, will give excellent service.

Since it is a high-quality product, Toro is concerned about the future use of the machine and safety of the user. Therefore, read this manual to familiarize yourself with proper set-up, operation and maintenance instructions. The major sections of the manual are:

- | | | |
|------------------------|---------------------|----------------|
| 1. Safety Instructions | 3. Before Operating | 5. Maintenance |
| 2. Set-up Instructions | 4. Lubrication | |

Certain information in this manual is emphasized. DANGER, WARNING and CAUTION identify personal safety-related information. IMPORTANT identifies mechanical information demanding special attention. Be sure to read this directive because it deals with the possibility of damaging a part or parts of the machine. NOTE identifies general information worthy of special attention.

TABLE OF CONTENTS

	Page		Page
SAFETY INSTRUCTIONS	2-4	Servicing Bushings in Castor Arms	9
SAFETY AND INSTRUCTION DECALS	5	Servicing Castor Wheel and Bearing	10
SPECIFICATIONS	5	Checking for Bent Blade	10
LOOSE PARTS	6	Removing Cutter Blade	10
SET-UP INSTRUCTIONS	6-7	Checking Sash and Sharpening Cutter Blade	11
Install Castor Wheels	6	Correcting Cutting Unit Mismatch	11
Mount Carrier Frame to Traction Frame	6	Replacing Grass Deflector	12
Install Drive Belt	6	Adjusting Idler Pulley	12
Install Rear Weight	7	Replacing Drive Belt	13
BEFORE OPERATING	7	Replacing Spindle Pulley	13
Adjusting Height-of-Cut	7	Removing Spindles and Bearings from Spindle Housing	13
OPERATING INSTRUCTIONS	8	IDENTIFICATION AND ORDERING	14
Grass Deflector	8	MAINTENANCE RECORD	15
LUBRICATION MAINTENANCE	8	THE TORO PROMISE	16
Grease Bearings, Bushings, and Gear Case ...	8		
CUTTING UNIT MAINTENANCE	9-14		
Troubleshooting	9		

SAFETY INSTRUCTIONS



The following instructions are comparable to the "Safe Operating Practices for Riding Vehicles" adopted by ANSI — American National Standards Institute B71.4-1984. The GROUNDMASTER 117 is designed and tested to offer reasonably safe service. Failure to operate the machine in accordance with these Safety Instructions MAY RESULT IN PERSONAL INJURY.

BEFORE OPERATING

1. Read and understand the contents of this Operator's Manual before starting and operating the machine. Become familiar with all controls and how to stop quickly. A replacement manual is available by sending complete Model and Serial Number to:

The Toro Company
8111 Lyndale Avenue South
Minneapolis, Minnesota 55420

2. Never allow children or adults unfamiliar with it's operation to operate the machine, and keep everyone, especially children and pets, away from the area of operation.

3. Remove sticks, stones, wire and any other debris or objects that might be picked up and thrown by the cutter blades.

SAFETY INSTRUCTIONS

4. Keep all shields and safety devices in place. If a shield, safety device or decal is defective or damaged, repair or replace it before operation is commenced. Also, tighten any loose nuts, bolts and screws to make sure machine is in safe operating condition.

5. Do not operate machine while wearing sandals, tennis shoes, sneakers or shorts. Also, do not wear loose fitting clothing because it could get caught in moving parts. Always wear long pants and substantial shoes. Wearing safety glasses, safety shoes and a helmet is advisable and required by some local ordinances and insurance regulations.

6. Be sure interlock switches are adjusted correctly so engine cannot be started unless traction pedal is released — neutral position — and PTO switch is in DISENGAGE position.

7. Fill fuel tank with gasoline before starting the engine. Avoid spilling any gasoline. Since gasoline is highly flammable, handle it carefully — DO NOT SMOKE.

- A. Use an approved gasoline container.
- B. Do not fill tank while engine is hot or running.
- C. Do not smoke while handling gasoline.
- D. Fill fuel tank outdoors and up to about one inch (25 mm) from top of the tank, not the filler neck. KEEP HOOD CLOSED when filling.
- E. Wipe up any spilled gasoline. Install gasoline container cap and machine fuel tank cap securely before starting the engine.

WHILE OPERATING

8. Do not run the engine in a confined area without adequate ventilation. Exhaust fumes are hazardous and could possibly be deadly.

9. Maximum seating capacity is one person. Never carry passengers.

10. Sit on the seat when starting the engine and operating the machine.

11. When starting the engine:

- A. Engage parking brake.
- B. Be sure traction pedal is in neutral and PTO is in disengage position.
- C. After engine is started, release parking brake and keep foot off traction pedal. Machine must not move. If movement is evident, the neutral return mechanism is ad-

justed incorrectly; therefore, shut engine off and adjust until machine does not move when traction pedal is released.

12. Using the machine demands attention, and to prevent loss of control:

- A. Mow only in daylight or when there is good artificial light.
- B. Watch for holes or other hidden hazards.
- C. Do not drive close to a sand trap, ditch, creek or other hazard.
- D. Reduce speed when making sharp turns and when turning on hillsides.
- E. Avoid sudden stops and starts.
- F. Before backing up, look to the rear to be sure no one is behind the machine.
- G. Watch out for traffic when near or crossing roads. Always yield the right-of-way.

13. The grass deflector must always be installed on the cutting unit. If the cutting unit discharge area ever plugs, disengage PTO and shut engine off. Use a stick to remove the obstruction.

14. Never raise the cutting unit while the blades are rotating.

15. If the cutting blades strike a solid object or the machine vibrates abnormally, disengage PTO, move throttle to SLOW, set parking brake and shut engine off. Remove key from switch and disconnect high tension wires from spark plugs to prevent possibility of accidental starting. Check cutting unit and traction unit for damage and defective parts. Make all repairs before restarting the engine and operating the cutting unit. Make sure blades are in good condition and blade nuts are tight.

16. Cut grass slopes carefully. When going uphill or downhill do not start or stop suddenly.

17. Do not touch engine, muffler or its adjacent shroud while engine is running or soon after it is stopped because these areas could be hot enough to cause a burn.

18. Lower the cutting unit or other attached implement to the ground and remove key from switch whenever machine is left unattended.

19. Before getting off the seat:

- A. Move traction pedal to neutral position and remove foot from pedal.
- B. Disengage the PTO and set the parking brake.

SAFETY INSTRUCTIONS

- C. Shut the engine off and remove key from ignition switch. Wait for all movement to stop before getting off the seat.

MAINTENANCE

- 20. Remove key from ignition switch and disconnect high tension wire from spark plug to prevent accidental starting of the engine when servicing, adjusting or storing the machine.
- 21. Perform only those maintenance instructions described in this manual. If major repairs are ever needed or assistance is desired, contact an Authorized TORO Distributor. Ask about Mobile Service Maintenance.
- 22. To reduce potential fire hazard, keep the engine free of excessive grease, grass, leaves and accumulations of dirt.
- 23. Be sure machine is in safe operating condition by keeping nuts, bolts and screws tight. Check the blade mounting nuts frequently to be sure they are tight.
- 24. Make sure all hydraulic line connectors are tight, and all hydraulic hoses and lines are in good condition before applying pressure to the system.
- 25. Keep body and hands away from pin hole leaks or nozzles that eject hydraulic fluid under high pressure. Use paper or cardboard, not hands, to search for leaks. Hydraulic fluid escaping under pressure can

have sufficient force to penetrate skin and do serious damage. If fluid is ejected into the skin it must be surgically removed within a few hours by a doctor familiar with this form of injury or gangrene may result.

26. Before disconnecting or performing any work on the hydraulic system, all pressure in system must be relieved by stopping engine and lowering implement to the ground.

27. If the engine must be running to perform a maintenance adjustment, keep hands, feet, clothing and other parts of the body away from the cutting unit blades and other moving parts.

28. Do not overspeed the engine by changing governor settings. Maximum engine speed (with engine coupled to transmission) is 3100-3300 rpm. To ensure safety and accuracy, have an Authorized TORO Distributor check maximum engine speed with a tachometer.

29. Engine must be shut off before checking oil or adding oil to the crankcase.

30. At the time of manufacture, the GROUNDS-MASTER 117 conformed to safety standards in effect for riding mowers. Therefore, to assure optimum performance and safety, always purchase genuine TORO replacement parts and accessories. Replacement parts and accessories made by other manufacturers could be dangerous. Such use could void the product warranty of The Toro Company.

CAUTION

1. KEEP ALL SHIELDS IN PLACE.
2. BEFORE LEAVING OPERATOR'S POSITION.
 - A. MOVE TRANSMISSION TO NEUTRAL.
 - B. DISENGAGE ATTACHMENT CLUTCH.
 - C. SET PARKING BRAKE.
 - D. SHUT OFF ENGINE.
 - E. REMOVE IGNITION KEY.
3. WAIT FOR ALL MOVEMENT TO STOP BEFORE SERVICING MACHINE.
4. KEEP BYSTANDERS FROM AREAS BEING MOWED.

SAFETY AND INSTRUCTION DECALS



The following decals are installed on the machine. If any become damaged or illegible, replace it. The decal part number is listed in your parts catalog. Replacement can be ordered from your Authorized Toro Distributor.

DO NOT STEP
CAUTION
 ROTATING BLADES UNDER ENTIRE MOWER DECK. KEEP HANDS AND FEET AWAY. DO NOT REMOVE DEFLECTOR CHUTE.

BLADE LINE

ON RIGHT SIDE OF CUTTING UNIT
 (Part No. 40-5730)

WARNING
 LOSS OF STEERING CONTROL AND FORWARD STABILITY MAY RESULT IN SERIOUS INJURY WHEN CUTTING UNIT IS IN RAISED POSITION WITHOUT ADDITIONAL WEIGHT. SEE OPERATOR MANUAL FOR COMPLETE INSTRUCTIONS.

GROUNDMASTER TRACTION UNITS MUST BE EQUIPPED WITH REAR WEIGHTS (PART NUMBER 24-5790) WITH THIS ATTACHMENT INSTALLED.

56-1670

ON FRONT OF CUTTING UNIT
 (Part No. 56-5670)

HEIGHT OF CUT ADJUSTMENT

TURN ENGINE OFF.

PLACE CLEVIS PINS IN HOLES CORRESPONDING TO DESIRED HEIGHT OF CUT.

MAKE SURE ALL FOUR PINS ARE POSITIONED IN IDENTICAL HOLE LOCATIONS

- 1"
- 1 1/2"
- 2"
- 2 1/2"
- 3"
- 3 1/2"
- 4"

ON CENTER DECK COVER
 (Part No. 42-6860)

CAUTION
 BLADE RETAINING BOLTS MUST BE TORQUED TO 75-100 ft/lbs. CHECK BLADE BOLT TORQUE AFTER STRIKING ANY SOLID OBJECT.

ON FRONT OF CUTTING UNIT
 (Part No. 26-7960)



ON LEFT SIDE OF CUTTING UNIT
 (Part No. 43-8480)

SPECIFICATIONS

CUTTING UNIT

Width of Cut: 51-3/4 in. (1.32 m).

Height-of-Cut: Adjustable from 1" to 4" (25 to 102 mm) in 1/2" (13 mm) increments.

Cutter Blades: Three heat treated steel blades, each 3/16 in. (4.8 mm) thick and 18 in. (457 mm) long.

Pneumatic Wheels: 8 in. (203 mm) dia. with greaseable roller bearings. (Inflation 10-15 P.S.I.)

Weight: 200 lb. (91 kg).

Unit Drive System: Belt drive from implement jackshaft to right angle gear box. Belt drive to all spindles.

LOOSE PARTS

Note: Use this chart as a checklist to assure all parts have been received. Without these parts, total set-up cannot be completed.

DESCRIPTION	QTY.	USE
Capscrews — 3/8-16 x 1-3/4" Lg. Locknuts Capscrews — 3/8-16 x 3/8" Lg. Lockwashers Shims	4 4 4 4 2	Mount carrier. Frame to traction frame.
Castor Wheel Assembly Thrust Washer Lynch Pin	2 8 2	Install in frame. Install on castor fork shafts. Install in top hole of castor shafts.
V-Belt	1	Mount to cutting unit and traction unit.
Capscrew — 1/2-13 x 1-1/2" Lockwasher — 1/2	2 2	Mount rear weight to frame.
Operator's Manual Registration Card	1 1	

SET-UP INSTRUCTIONS

INSTALL CASTOR WHEELS

- Place two thrust washers on each castor wheel shaft (Fig. 1).

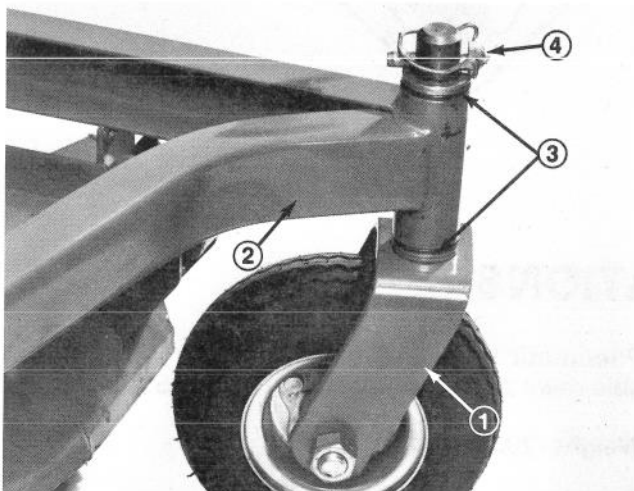

Figure 1

1. Castor wheel assembly
2. Frame
3. Thrust washers
4. Lynch pin

- Insert shafts into carrier frame. Install two more thrust washers and secure with lynch pins (Fig. 1).

MOUNT CARRIER FRAME TO TRACTION FRAME

- Align carrier frame mounting holes with mounting holes in traction frame, while positioning shim on traction frame and aligning mounting holes (Fig. 2).

- Secure each side with (2) 3/8-16x1-3/4" lg. capscrews and locknuts. Locknuts must be positioned outside carrier frame.

- Secure top of each carrier frame and shim to traction frame with (2) 3/8-16x3/8" lg. capscrews and lockwashers. Torque fasteners to 240-320 in. lb.

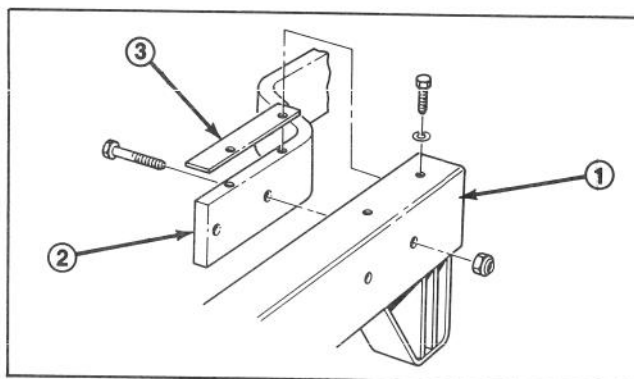

Figure 2

1. Carrier frame
2. Traction frame
3. Shim

INSTALL DRIVE BELT

- Unhook latch to release center deck cover from housing, and remove cover to expose gear box pulley (Fig. 3).

- Route V-belt around jackshaft pulley and gear box pulley (Fig. 4).

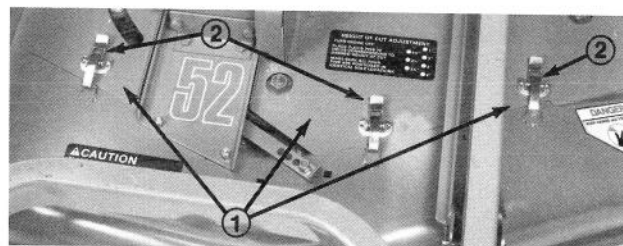

Figure 3

1. Belt covers
2. Cover latches

SET-UP INSTRUCTIONS

3. Raise idler pulley and position over upper portion of belt (Fig. 4).

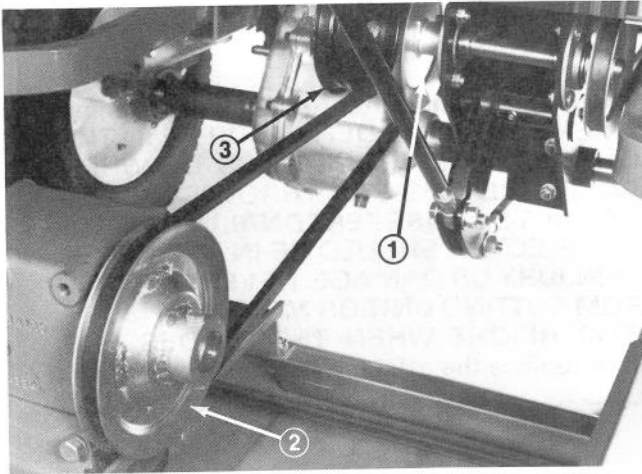

Figure 4

1. Jackshaft pulley 2. Gear box pulley 3. Idler pulley

4. Reinstall belt cover and secure latches to housing.

INSTALL REAR WEIGHT



CAUTION

To insure proper handling and safety characteristics, a 35 lb. rear weight must be attached to Groundsmaster 117 traction unit.

1. Locate mounting holes under Toro decal in rear frame.
2. Cut away decal material to expose holes.
3. Mount weight to frame with (2) 1/2 - 13 x 1-1/2" lg. capscrews and lockwashers (Fig. 5).

Note: Order parts from your Authorized Toro Distributor.

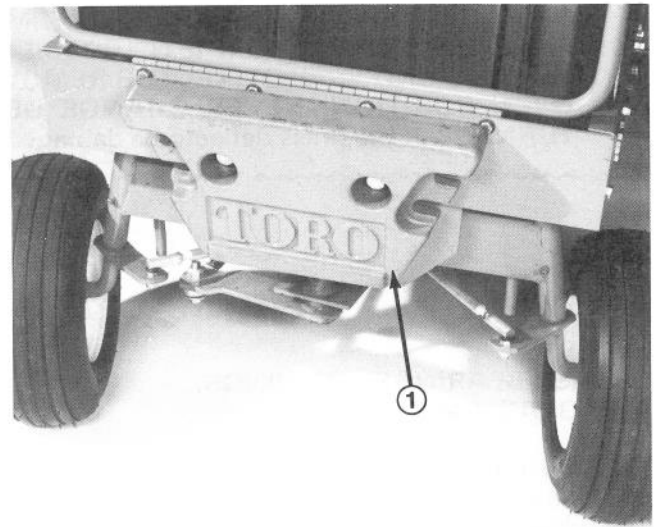

Figure 5

1. Rear weight

BEFORE OPERATING

ADJUSTING HEIGHT-OF-CUT

The height-of-cut is adjustable from 1 to 4 inches (25 to 102 mm) in 1/2 inch (13 mm) increments by relocating four clevis pins in different hole locations in brackets at each corner of the cutting unit (Fig. 6).

Note: All four pins should be in identical hole locations to prevent any operating and cutting difficulties.

Note: If cutting unit is to be used in 1 in. (25 mm) or 1-1/2 in. (38 mm) height-of-cut setting, rear cutting unit rollers must be repositioned in the top bracket holes.

1. Remove cotter pins from roller shafts.
2. Slide shafts out of lower bracket holes, align rollers with top holes and install shafts.
3. Install cotter pins to secure assemblies.

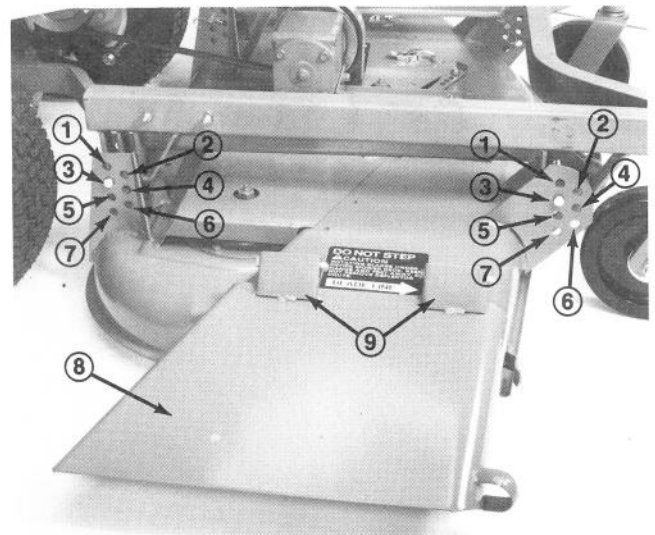

Figure 6

- | | | |
|----------------------|----------------------|--------------------|
| 1. 1 in. (25 mm) | 4. 2-1/2 in. (64 mm) | 7. 4 in. (102 mm) |
| 2. 1-1/2 in. (38 mm) | 5. 3 in. (76 mm) | 8. Grass deflector |
| 3. 2 in (51 mm) | 6. 3-1/2 in. (89 mm) | 9. Spring hinges |

OPERATING INSTRUCTIONS

GRASS DEFLECTOR



WARNING

The grass deflector (Fig. 6) is a safety device that diverts grass and other foreign objects being discharged downwardly. WE STRONGLY RECOMMEND THAT THE DEFLECTOR BE IN THE LOWEST POSITION WHENEVER THE MACHINE IS USED NEAR BUILDINGS OR WHEN THERE ARE PEOPLE OR ANIMALS IN THE AREA. THE BLADES CAN THROW DEBRIS A CONSIDERABLE DISTANCE WITH SUFFICIENT FORCE TO CAUSE PERSONAL INJURY OR DAMAGE TO PROPERTY. THE ONLY TIME THE DEFLECTOR SHOULD BE IN THE UPPER POSITION IS WHEN THERE IS NO POSSIBILITY OF INJURY OR DAMAGE. NEVER OPERATE CUTTING UNIT WITH DEFLECTOR REMOVED FROM CUTTING UNIT OR MOVED TO MORE OPEN POSITION. NEVER CHANGE DEFLECTOR HEIGHT WHEN THE BLADES ARE TURNING. If the grass deflector is damaged, repair or replace the affected part(s).

LUBRICATION MAINTENANCE

GREASE BEARINGS, BUSHINGS, AND GEAR CASE

1. The cutting unit must be lubricated regularly. If machine is operated under normal conditions, lubricate blade spindle bearings, castor bearings and castor bushings with No. 2 general purpose lithium grease or molybdenum base grease, after every 8 hours of operation or daily, whichever comes first (Fig. 7 & 8).

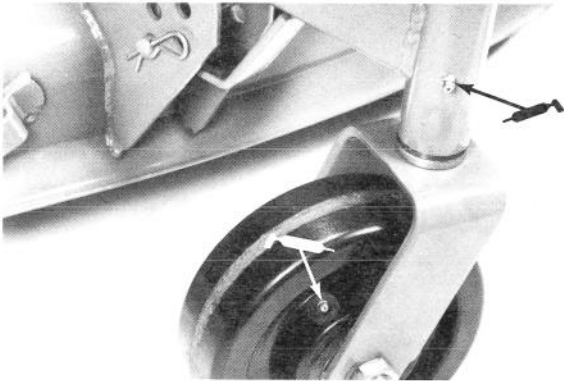

Figure 7

2. After every 50 hours of operation, lower cutting unit so castor wheels are on a level surface. Be sure all height-of-cut pins are in the same hole locations. Clean area around gear box filler plug (Fig. 8) to prevent contaminants from entering gear box. Remove filler plug and check level of lubricant. If level of lubricant is low, add SAE E.P. 90 wt. oil until oil level is up to bottom of filler hole. Reinstall filler plug.

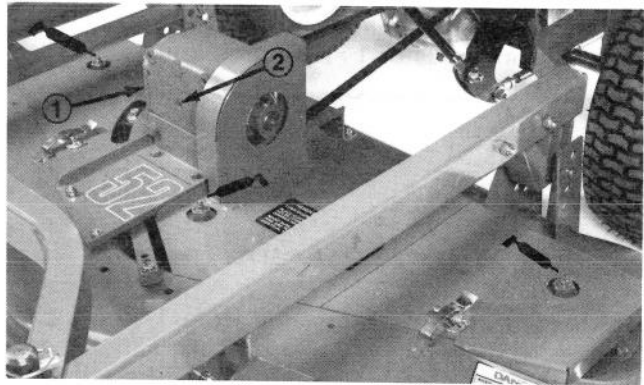
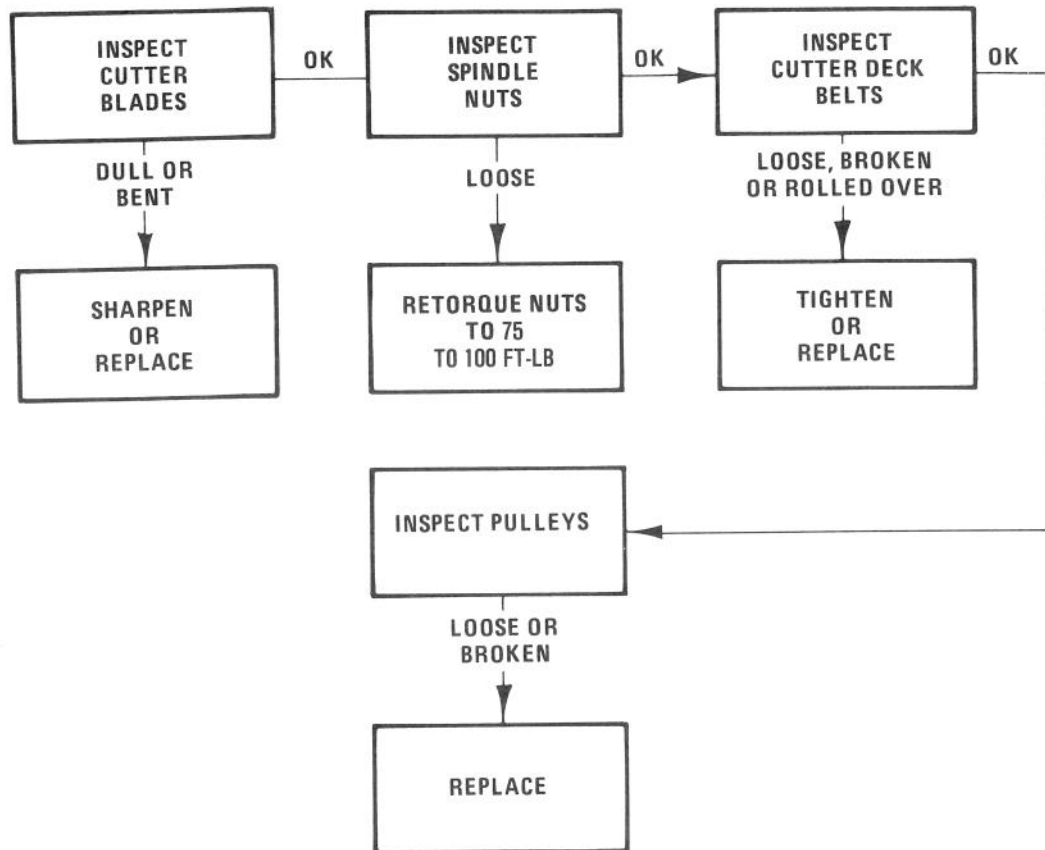

Figure 8

1. Gear box
2. Filler plug

CUTTING UNIT MAINTENANCE TROUBLESHOOTING

UNIT WILL NOT CUT OR CUTS POORLY



CUTTING UNIT MAINTENANCE

SERVICING BUSHINGS IN CASTOR ARMS

The castor arms have bushings pressed into the top and bottom portion of the tube and after many hours of operation, the bushings will wear. To check the bushings, move castor fork back and forth and from side-to-side. If castor spindle is loose inside the bushings, bushings are worn and must be replaced.

1. Raise cutting unit so wheels are off floor and block it so it cannot fall accidentally.
2. Remove lynch pin and thrust washers from top of castor spindle.
3. Pull castor spindle out of mounting tube. Allow thrust washers to remain on bottom of spindle.

4. Insert pin punch into top or bottom of mounting tube and drive bushing out of tube (Fig. 9).

Also drive other bushing out of tube. Clean inside of tubes to remove dirt.

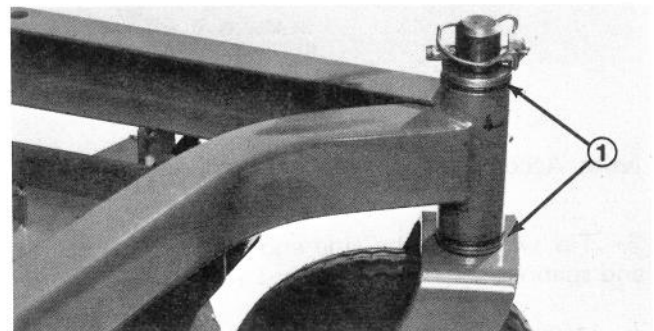

Figure 9
1. Bushings

CUTTING UNIT MAINTENANCE

5. Apply grease to inside and outside of new bushings. Using a hammer and flat plate, drive bushings into mounting tube.
6. Inspect castor spindle for wear and replace it if damaged.
7. Push castor spindle through bushings and mounting tube. Slide spacers onto spindle. Install lynch pin through castor spindle to retain all parts in place.

IMPORTANT: When bushings are installed, the inside diameter may collapse slightly, and this may not allow castor spindle to be installed. If castor spindle does not slide through new bushings and mounting tube, ream both bushings to inside diameter of 1.126 inches (28.6 mm).

SERVICING CASTOR WHEEL AND BEARING

The castor wheel rotates on a high-quality roller bearing and is supported by a spanner bushing. Even after many hours of use, provided that the bearing was kept well-lubricated, bearing wear will be minimal. However, failure to keep bearing lubricated will cause rapid wear. A wobbly castor wheel usually indicates a worn bearing.

1. Remove locknut from capscrew holding castor wheel assembly between castor fork (Fig. 10). Grasp castor wheel and slide capscrew out of fork.

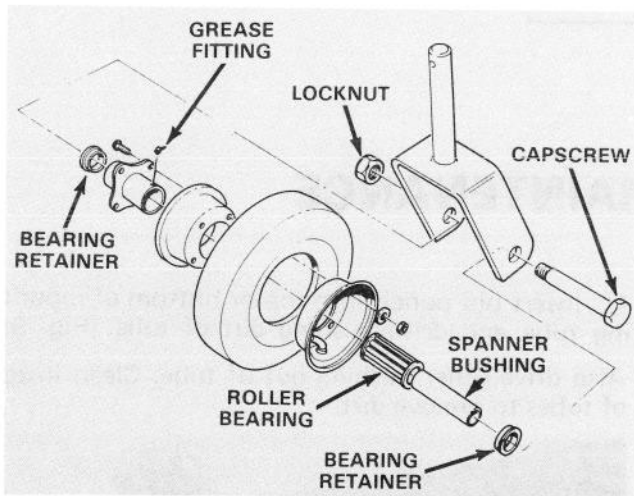

Figure 10

Note: Account for the two bearing retainers (Fig. 10).

2. Tip wheel to the side and allow roller bearing and spanner bushing to fall out (Fig. 10).
3. Inspect bearing, spanner bushing and inside diameter of wheel for wear. Replace defective parts.

4. To reassemble parts, slide spanner bushing through roller bearing. Pack bearing with no. 2 grease; then insert bearing w/spanner bushing into wheel.

5. Slide bearing retainer and thrust washer onto spanner bushing, and mount castor wheel assembly between the fork and capscrew and locknut. Tighten capscrew and locknut until spanner bushing bottoms against inside of castor fork.

6. Pump more grease through grease fitting on wheel (Fig. 10) until bearing is greased thoroughly.

CHECKING FOR BENT BLADE

1. Rotate blade until the ends face forward and backward (Fig. 11). Measure from inside of cutting unit to cutting edge at front of blade (Fig. 11), and remember this dimension.

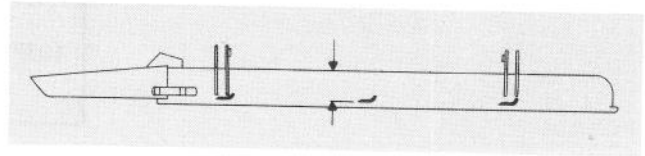

Figure 11

2. Rotate opposite end of blade forward. Measure between the cutting unit and cutting edge of blade at the same position as in step 1. The difference between dimensions obtained in steps 1 and 2 must not exceed 1/8 of an inch (3 mm). If dimension exceeds 1/8 of an inch (3 mm), replace the blade because it is bent: refer to Removing Cutter Blade, page 10.

REMOVING CUTTER BLADE

The blade must be replaced if a solid object is hit, the blade is out-of-balance or if the blade is bent. Always use genuine TORO replacement blades to be sure of safety and optimum performance. Never use replacement blades made by other manufacturers because they could be dangerous.



WARNING

Do not try to straighten a blade that is bent, and never weld a broken or cracked blade. Always use a new blade to assure safety.

1. Grasp end of blade using a rag or thickly padded glove. Remove locknut and blade from spindle shaft.
2. Install blade — sail facing toward cutting unit with locknut. Tighten to 75-100 ft-lb (102-136 N·m).

CUTTING UNIT MAINTENANCE

CHECKING SAIL AND SHARPENING CUTTER BLADE

Two areas must be considered when checking and servicing the cutter blade: one area is the sail, the other is the cutting edge. Both cutting edges and the sail, which is the turned up metal opposite the cutting edge, contribute to a good quality-of-cut. The sail is important because it pulls grass up straight, thereby producing an even cut. However, the sail will gradually wear down during operation, and this condition is normal. As the sail wears down, the quality-of-cut will degrade somewhat, although the cutting edges are sharp. The cutting edges of the blade must be sharp so the grass is cut rather than torn. A dull cutting edge is evident when tips of the grass appear brown and shredded. Sharpen the cutting edges to correct this condition.

1. Examine cutting ends of the blade carefully, especially where the flat and curved parts of the blade meet (Fig. 12-1). Since sand and abrasive material can wear away the metal that connects the flat and curved parts of the blade, check the blade before using the mower. If wear is noticed (Fig. 12-2), replace the blade.

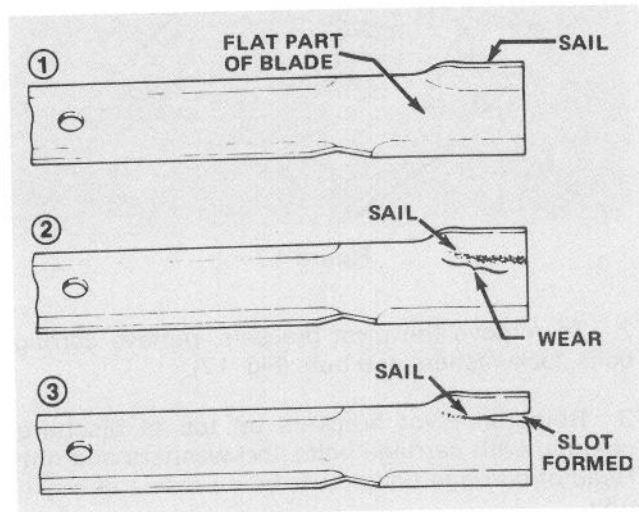

Figure 12



DANGER

If blade is allowed to wear, a slot will form between the sail and flat part of the blade (Fig. 12-3). Eventually a piece of the blade may break off and be thrown from under the housing, possibly resulting in serious injury to yourself or bystander.

2. Inspect cutting edges of all blades. Sharpen the cutting edges if they are dull or nicked. Sharpen only the top of the cutting edge and maintain the original cutting angle to make sure of sharpness (Fig. 13). The blade will remain balanced if same amount of metal is removed from both cutting edges.

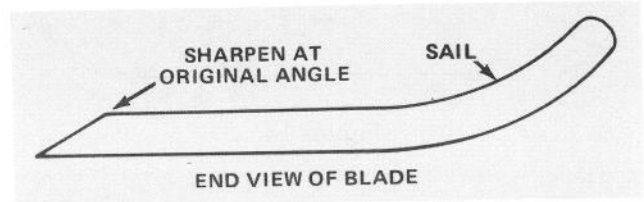

Figure 13

Note: Remove the blades and sharpen them on a grinder: refer to Removing Cutter Blade, page 10. After sharpening the cutting edges, reinstall blade with locknut. Blade sails must be toward top of deck. Tighten locknut to 50-60 ft-lb (68-81 N-m).

CORRECTING CUTTING UNIT MISMATCH

If one cutter blade cuts lower than the others, correct as follows:

1. Check to make sure front height-of-cut pins are resting properly on frame cushions (Fig. 16).
2. Raise height-of-cut to the 3½" (89 mm) or 4 in. (102 mm) position (Fig. 16): refer to Adjusting Height-Of-Cut, page 7.
3. Rotate blades so tips line up with one another. Tips of the adjacent blades must be within 1/8 in. (3 mm) of each other. If tips are not within 1/8 in. (3 mm) of each other, proceed to step 7 and add shims between spindle housing and bottom of cutting unit.
4. Position all three blades in the "A" position (Fig. 15) and measure from level surface to the bottom of the tip end of each blade (Fig. 15).
5. Note measurement attained at "A", rotate blades to "B" position (Fig. 14), measure distance of all blades to level surface and note dimensions (Fig. 15).
6. Rotate blades to "C" position, measure and note distance measured (Fig. 14, 15).
7. Compare measurements at various positions. All dimensions must be equal within 1/4 in. (6 mm) from one another. The difference between dimensions must not exceed 1/4 in. (6 mm). If difference exceeds 1/4 in. (6 mm), proceed to step 8 and 9 and add shims between spindle housing and bottom of cutting unit.

CUTTING UNIT MAINTENANCE

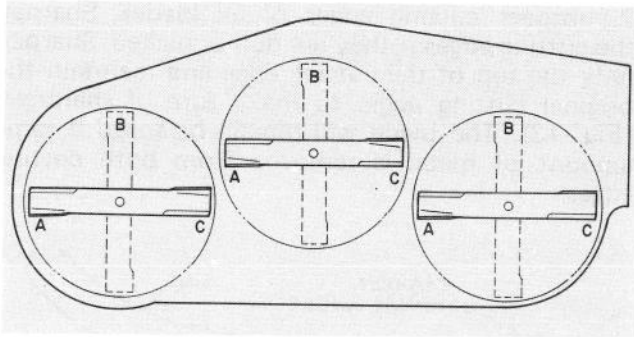

Figure 14

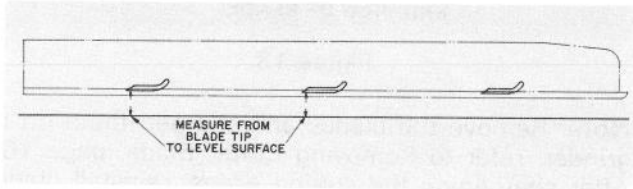

Figure 15

8. Remove flange bolts and nuts from outer spindle in the area where shims must be added. To raise or lower the blade, add a shim, Part No. 3256-24, between spindle housing and bottom of cutting unit. Continue checking alignment of blades and adding shims until tips of blades are within the required dimension.

9. Equalize side to side measurements as follows:

A. Cutting units usually operated at 1 to 2 in. (25 to 51 mm) height-of-cut should have the low side of the cutting unit raised. Remove the lynch pin securing castor wheel on low end (Fig. 16) and remove castor assembly.

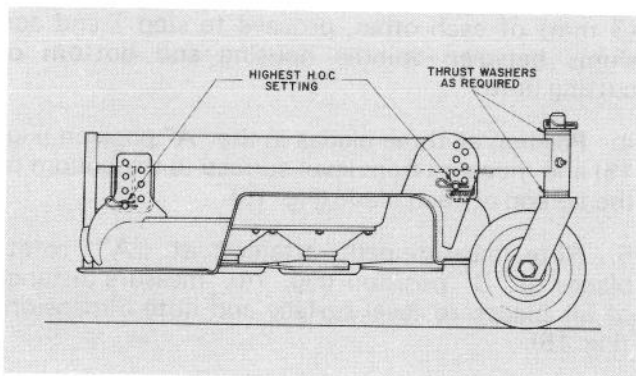

Figure 16

B. Transfer one thrust washer from top side of castor shaft to lower side, install castor assembly and compare blade height of all blades; refer to items 3 through 7. Continue adding thrust washers if height still does not meet requirements.

C. If cutting unit is operated at 2 to 4 in. (51 to 102 mm) height-of-cut, lower the high side of cutting unit. Remove lynch pin of castor at high end of unit and remove castor assembly (Fig. 14).

D. Transfer one thrust washer from lower side of castor shaft to top side, install assembly and compare blade height of all blades; refer to items 3 through 7. Repeat procedure if height still does not meet requirements.

E. If height is within specified dimension, install lynch pin, set height-of-cut to proper height and resume operation.

REPLACING GRASS DEFLECTOR

1. Remove two capscrews, locknuts and springs securing deflector mounts to pivot brackets (Fig. 17).

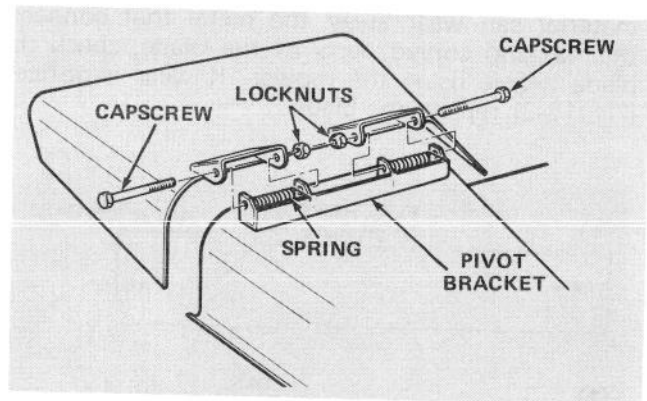

Figure 17

2. To remove the pivot brackets, remove carriage bolts, lockwashers and nuts (Fig. 17).

3. Reinstall pivot brackets on top of discharge opening with carriage bolts, lockwashers and nuts. Head of carriage bolts must be on inside of cutting unit.

4. Position deflector mounts on outside of pivot brackets and secure parts together with capscrews, locknuts and springs. Both locknuts must face each other. Tighten locknuts until they are flush against deflector pivots. Lift deflector and allow it to drop to check spring tension. Deflector must be held firmly in full downward position by spring tension. Correct if necessary.

ADJUSTING IDLER PULLEY

The idler pulley applies force against the belt so power can be transmitted to the blade pulleys. If the idler is not tensioned against the belt with sufficient force,

CUTTING UNIT MAINTENANCE

maximum power will not be transmitted to the pulleys.

1. Release and unhook latches securing belt covers to top of cutting unit. Remove covers.
2. Remove nut securing spring anchor to capscrew in housing (Fig. 18). Lift anchor off capscrew and pull to increase belt tension. Correct belt tension is achieved when approximately 30-40 lbs. of force is applied to spring.

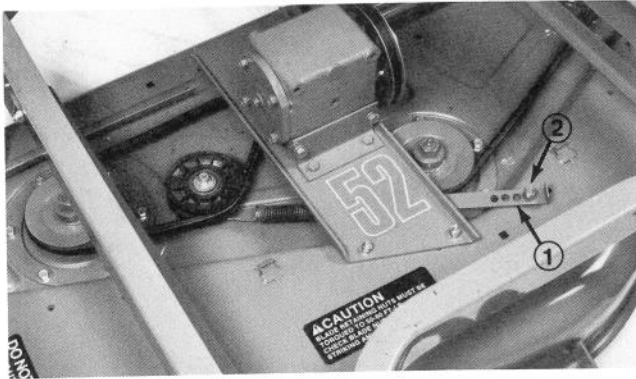

Figure 18

1. Spring anchor
2. Nut

3. Reinstall spring anchor on capscrew in appropriate mounting hole and install nut.
4. Reinstall belt covers.

REPLACING DRIVE BELT

The blade drive belt, tensioned by the spring loaded idler, is very durable. However, after many hours of use, the belt will show signs of wear. Signs of a worn belt are: squealing when belt is rotating, blades slipping when cutting grass, frayed edges, burn marks and cracks. Replace the belt if any of these conditions are evident.

1. Release and unhook latches securing belt covers to top of cutting unit. Remove covers.
2. Remove nut securing spring anchor to capscrew in housing (Fig. 18). Lift anchor off capscrew and allow belt to relax.
3. Remove worn belt from pulleys and slide one end of belt under gear box bracket to remove.
4. Install new belt around spindle pulleys, gearbox pulley, and idler pulley (Fig. 19).
5. Readjust belt tension; refer to Adjusting Idler Pulley, page 12.
6. Reinstall belt covers.

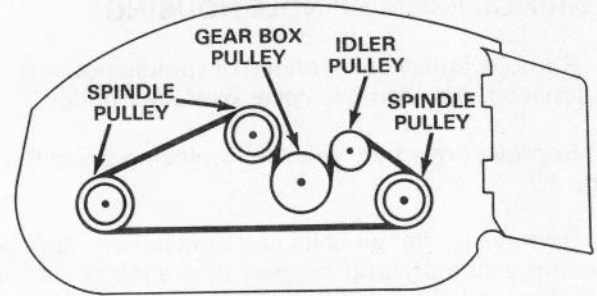

BELT ROUTING

Figure 19

REPLACING SPINDLE PULLEY

1. Remove covers from cutting unit.
2. Remove drive belt, refer to Replacing Drive Belt, page 13.
3. Remove six flange bolts and nuts holding spindle housing assembly and support ring against cutting unit (Fig. 20). Slide spindle housing assembly out bottom of cutting unit.

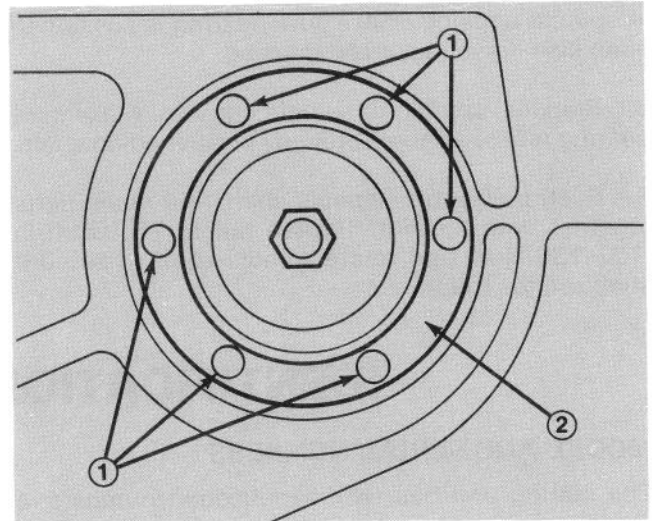

Figure 20

1. Flange bolts
2. Support ring

4. Remove nut retaining pulley on spindle shaft. Pull pulley off shaft.
5. Install new pulley on spindle shaft with locknut. Tighten nut to 50-60 ft-lb (68-81 N·m).
6. Slide pulley end of spindle housing assembly through hole in cutting unit. Mount spindle assembly and support ring in place with six flange bolts and nuts.
7. Reinstall belts and covers.

CUTTING UNIT MAINTENANCE

REMOVING SPINDLES AND BEARINGS FROM SPINDLE HOUSING

1. Remove pulley cover on top of spindle housing to be serviced. Also remove cover over idler pulley.
2. Remove drive belt, refer to Replacing Drive Belt, page 13.
3. Remove six flange bolts and nuts holding spindle housing assembly and support ring against cutting unit (Fig. 20). Slide spindle housing assembly out bottom of cutting unit.
4. Remove locknut retaining spindle pulley on spindle shaft. Slide pulley off shaft, which will allow spindle shaft to be removed from spindle housing.
5. If spindle shaft will be replaced, remove locknut securing blade to spindle. Otherwise, the blade may be left on spindle shaft.
6. Remove dust cover to expose bearing and spacer in spindle housing (Fig. 21).

Note: Only top bearing in spindle housing is removable.

7. Reposition spacer with grease shield and bearing in spindle housing. Make sure bearing is positioned open side down in spindle housing.
8. Reinstall spindle in spindle housing. Make sure bearing and spacer are properly positioned on shaft.
9. Push pulley onto spindle shaft, and retain parts together with locknut. Tighten nut to 75-100 ft-lb (102-136 N·m) and rotate spindle shaft to be sure shaft rotates freely.

10. Slide pulley end of spindle assembly through hole in cutting unit. Mount spindle assembly in place with support ring and six flange bolts and nuts (Fig. 21).

11. Reinstall belts and covers.

12. Grease spindle bearings (approximately 2-3 oz.).

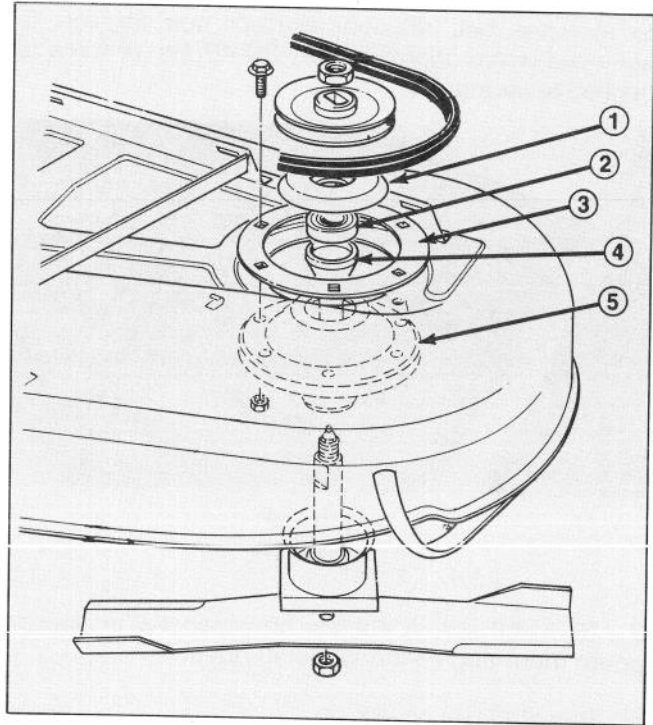

Figure 21

1. Dust cover
2. Bearing
3. Support ring
4. Spacer w/ grease shield
5. Spindle housing

IDENTIFICATION AND ORDERING

MODEL AND SERIAL NUMBERS

The cutting unit has two identification numbers: a model number and a serial number. These numbers are stamped into a plate. The cutting unit identification plate is located behind the right front caster wheel on carrier frame (Fig. 22). In any correspondence concerning the cutting unit, supply the model and serial numbers to assure correct information and replacement parts are obtained.

To order replacement parts from an authorized TORO Distributor, supply the following information:

1. Model and serial numbers of the cutting unit.
2. Part number, description and quantity of parts desired.

Note: Do not order by reference number if a parts catalog is being used; use the part number.

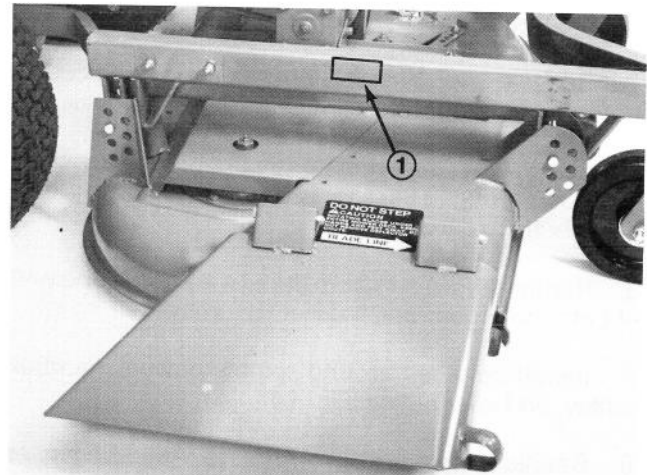

Figure 22

1. Model and serial number

The Toro Promise

A ONE YEAR LIMITED WARRANTY

The Toro Company promises to repair your TORO Product if defective in materials or workmanship. The following time periods from the date of purchase apply:

Commercial Products 1 Year

The costs of parts and labor are included, but the customer pays the transportation costs on walk rotary mowers with cutting unit widths of less than 25".

If you feel your TORO product is defective and wish to rely on The Toro Promise, the following procedure is recommended:

1. Contact your Authorized TORO Distributor or Commercial Dealer (the Yellow Pages of your telephone directory is a good reference source).
2. The TORO Distributor or Commercial Dealer will advise you on the arrangements that can be made to inspect and repair your product.
3. The TORO Distributor or Commercial Dealer will inspect the product and advise you whether the product is defective and, if so, make all repairs necessary to correct the defect without an extra charge to you.

If for any reason you are dissatisfied with the distributor's analysis of the defect or the service performed, you may contact us.

Write:

TORO Commercial Products Service Department
8111 Lyndale Avenue South
Minneapolis, Minnesota 55420

The above remedy of product defects through repair by an Authorized TORO Distributor or Commercial Dealer is the purchaser's sole remedy for any defect.

THERE IS NO OTHER EXPRESS WARRANTY. ALL IMPLIED WARRANTIES OF MERCHANTABILITY AND FITNESS FOR USE ARE LIMITED TO THE DURATION OF THE EXPRESS WARRANTY.

Some states do not allow limitations on how long an implied warranty lasts, so the above limitation may not apply to you.

This Warranty applies only to parts or components which are defective and does not cover repairs necessary due to normal wear, misuse, accidents, or lack of proper maintenance. Regular, routine maintenance of the unit to keep it in proper condition is the responsibility of the owner.

All warranty repairs reimbursable under the Toro Promise must be performed by an Authorized TORO Commercial Dealer or Distributor using Toro approved replacement parts.

Repairs or attempted repairs by anyone other than an Authorized TORO Distributor or Commercial Dealer are not reimbursable under the Toro Promise. In addition, these unauthorized repair attempts may result in additional malfunctions, the correction of which is not covered by warranty.

THE TORO COMPANY IS NOT LIABLE FOR INDIRECT, INCIDENTAL OR CONSEQUENTIAL DAMAGES IN CONNECTION WITH THE USE OF THE PRODUCT INCLUDING ANY COST OR EXPENSE OF PROVIDING SUBSTITUTE EQUIPMENT OR SERVICE DURING PERIODS OF MALFUNCTION OR NON-USE.

Some states do not allow the exclusion or limitation of incidental or consequential damages, so the above limitation or exclusion may not apply to you.

This warranty gives you specific legal rights, and you may also have other rights which vary from state to state.

COUNTRIES OTHER THAN THE UNITED STATES OR CANADA

Customers who have purchased TORO products exported from the United States or Canada should contact their TORO Distributor (Dealer) to obtain guarantee policies for your country, province or state. If for any reason

you are dissatisfied with your Distributor's service or have difficulty obtaining guarantee information, contact the TORO importer. If all other remedies fail, you may contact us at The Toro Company.