



Proline 21''

Recycler[®] /Rear Bagging Mower

Model No. 22161-20000001 and Up

Parts Catalog

Ordering Replacement Parts

To order replacement parts, please supply: the part number, the quantity, and the description of each part desired.

Understanding Reference Numbers

Each identified part in an illustration has a reference number. The reference number for a part also appears in the parts list, along with other information about the part.

This catalog uses two special reference number formats, one to indicate parts in a service assembly and another to indicate the quantity of a given part in an illustration.

Service Assembly Reference Numbers

Parts in service assemblies have reference numbers in the form **a:b**. The **a** represents the reference number of the entire service assembly and the **b** represents a sequential number unique to each part within the service assembly.

For example, a wheel assembly might be identified by reference number **6**, the tire by **6:1**, the valve by **6:2**, and the wheel by **6:3**. When you order the assembly identified by reference number **6**, you receive all parts identified by reference numbers **6:1**, **6:2**, and **6:3**. However, you may also order any part individually.

Reference numbers of this type appear in illustrations and in part lists.

Reference Numbers Indicating Quantity

In an illustration, if a reference number indicates more than one part, the reference number has the form **nX y**. The **n** represents the quantity of the part, the **X** is the multiplication symbol, and the **y** represents the reference number.

For example, in an illustration, the reference number **2X 37** means that two of the parts identified by reference number **37** are indicated.

Contents

Description	Page	Description	Page
Housing Assembly	3	Rear Wheel & Gear Case Assembly	9
Front Wheel & Tire Assembly	4	Rear Wheel & Tire Assembly	10
Gear Case Assembly	5	Grass Bagging Assembly	11
Engine Assembly	6	Engine GTS-200	12-20
Gas Tank Assembly	7	Maintenance	21-23
Handle Assembly	8		

Accessories

Description	Model / Part No.	Description	Model / Part No.
Side Discharge Kit	Model No. 59199		

Part Description Abbreviations

Part descriptions in this catalog may include the following abbreviations.

Abbreviation	Meaning	Abbreviation	Meaning
AR	as required	INC	incorporated
ASM	assembly	LH	left hand
CARR	carriage	NI	nylon insert
DEG	degrees	PPH	Phillips pan head
FH	flat head	PTH	Phillips truss head
GA	gauge	PTO	power take off
HF	hex flange	RH	right hand
HH	hex head	SFH	slotted fillister head
HHF	hex head flange	SHH	slotted hex head
HLH	hex lag head	SQH	square head
HJ	hex jam	SHWH	slotted hex washer head
HOC	height-of-cut	SPH	slotted pan head
HS	hex socket	SRH	slotted round head
HSBH	hex socket button head	STD	standard
HSFH	hex socket flat head	TAP	self tapping
HSH	hex socket head	TTH	Torx truss head
HWH	hex washer head	WH	wing head
HWHTF	hex washer head thread forming		

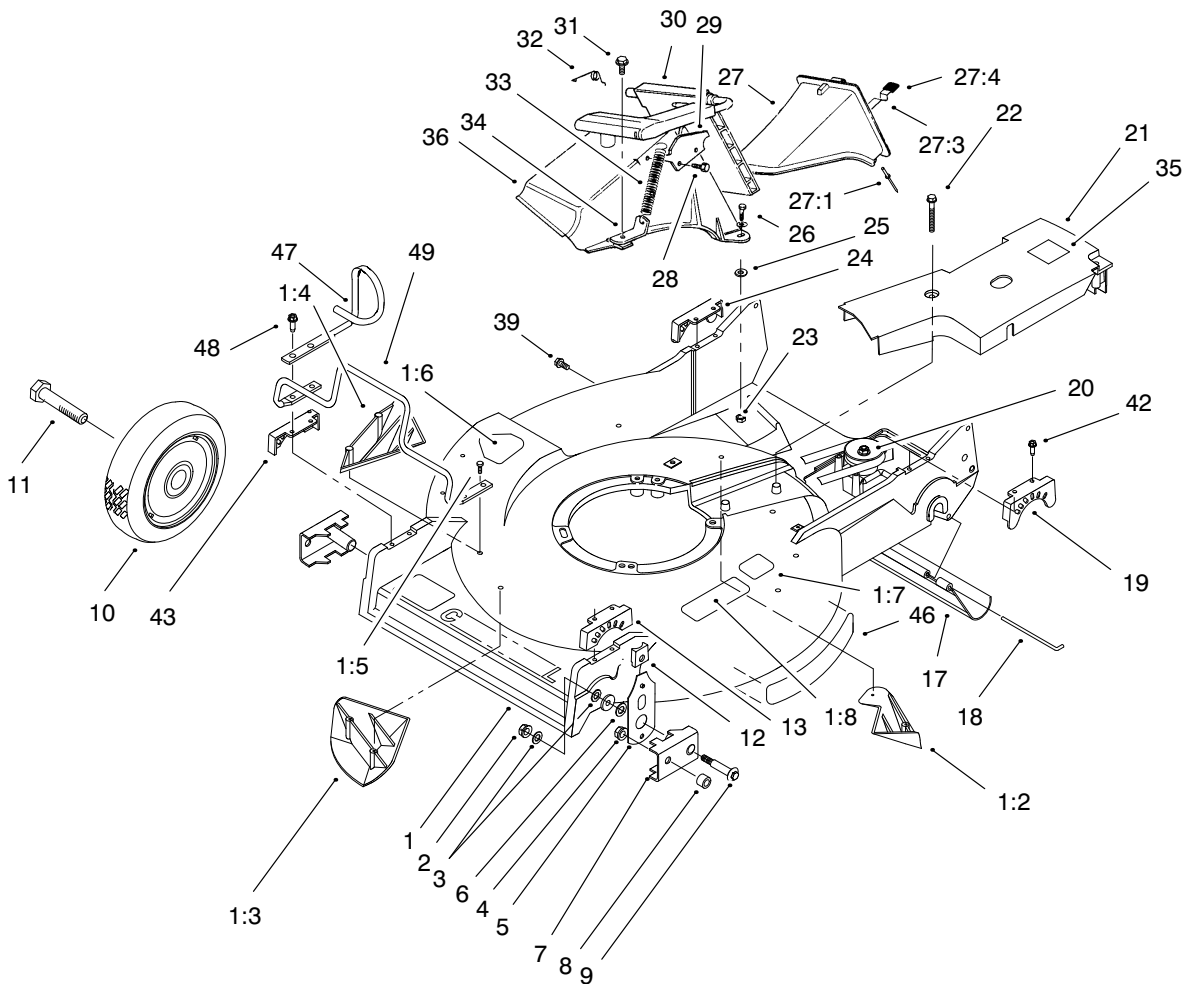

Sheet No.:2

Housing Assembly

Ref. No.	Part No.	Qty.	Description	Ref. No.	Part No.	Qty.	Description
1	98-7139	1	Housing – Service	23	3296-42	2	Nut-Lock
1:2	92-1750	1	Kicker – Rear, Sp	24	49-8750	1	Quadrant-RH Rear
1:3	92-1720	1	Kicker – Front	25	3256-22	2	Washer-Flat
1:4	92-1730	1	Kicker-RH	26	321-7	2	Screw-HH
1:5	32144-111	6	Screw-PPH	27	77-0500	1	Discharge Plug Assembly
1:6	39-5770	1	Decal – Cut Finger	27:1	3295-35	1	Rivet-Flat Hd
1:7	88-1270	1	Decal – Safety Instruct	27:3	76-4640	1	Latch-Discharge Plug
1:8	93-0248	1	Decal-Warning	27:4	76-4650	1	Grip-Latch
2	3296-6	2	Nut-Lock Ni	28	46-8090	2	Screw-Plastite
3	40-1940	4	Washer-Wheel Bolt	29	93-3154	1	Latch-Plate
4	32152-2	2	Nut-Conelock	30	93-7351	1	ASM – Discharge Door
5	66-7560	2	Front Spring Arm ASM	31	46-6811	1	Screw & Washer ASM
6	257-3	2	Washer-Thrust	32	80-3770	1	Retainer-Door
7	61-8300	2	Pivot Arm Wa – Front	33	76-4660	1	Spring-Door
8	52-2480	2	Spacer-Wheel	34	71-9350	1	Bracket-Spring
9	27-6232	2	Bolt-Wheel	35	52-2620	1	Label-Sp Grease
10	53-7720	2	Wheel & Tire ASM	36	82-9152	1	Tunnel-Discharge
11	323-12	2	Screw-HH	39	46-6810	1	Screw & Washer ASM
12	25-7740	2	Knob-Arm	42	49-2040	4	Screw-Taptite
13	49-8760	1	Quadrant-LH Front	43	49-8770	1	Quadrant-RH Front
17	44-0580	1	Shield – Trailing	46	92-7988	1	Decal – Recycler
18	33-3208	1	Rod-Shield	47	98-9227	1	Guard – Primer
19	49-8740	1	Quadrant-LH Rear	48	32144-86	4	Screw-HH
20	74-1860	1	Gear Case Assembly	49	99-6722	1	Guard Engine
21	98-3214	1	Cover-Belt, Sp (Com'l)				
22	37-7260	2	Screw-HH				

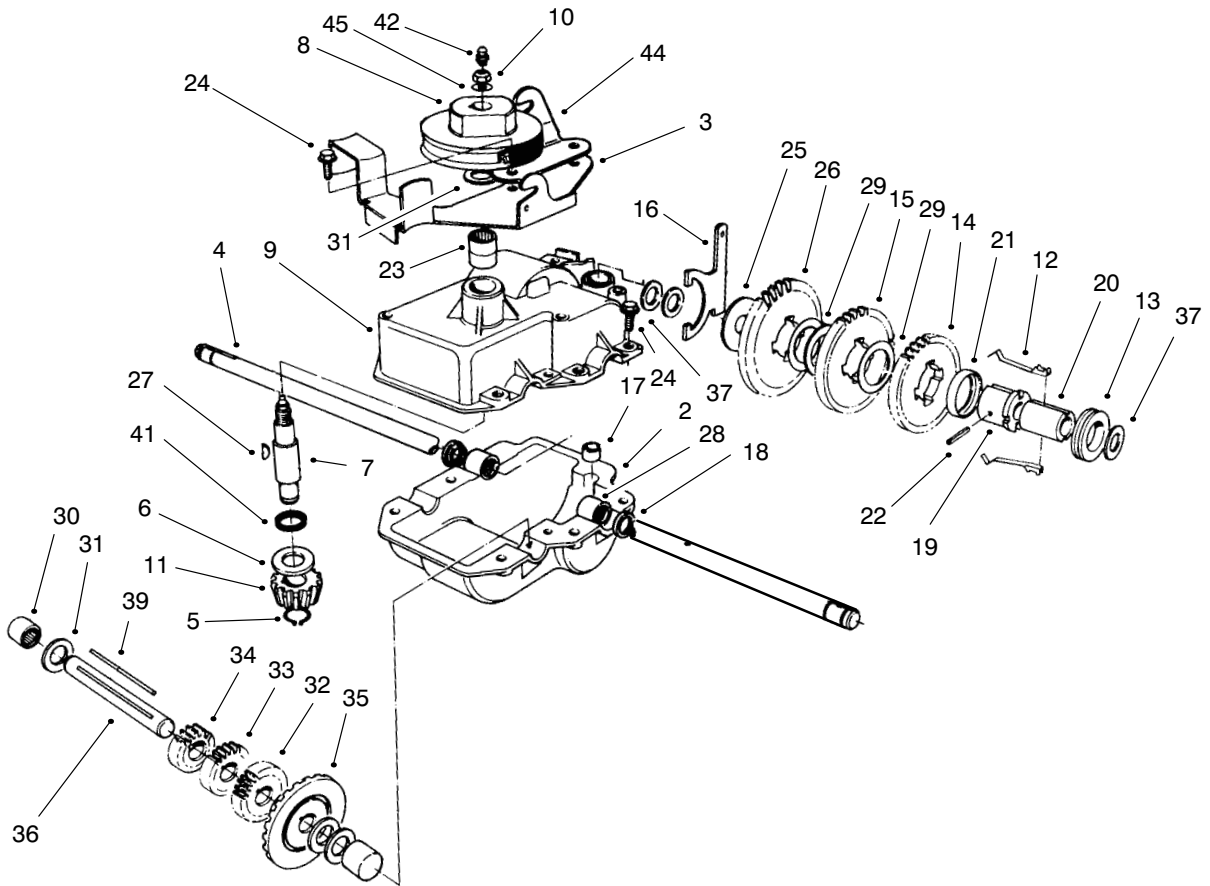

Sheet No.:A2

Gear Case Assembly

Ref. No.	Part No.	Qty.	Description
2	74-1920	1	Case-Lower Gear
3	49-8461-03	1	Bracket-Belt Guide
4	74-1890	1	Shaft-Output
5	32151-57	1	Ring-Retaining
6	47-2910	1	Washer-Thrust
7	13-5149	1	Input Shaft w/Zerk
8	39-6740	1	Pulley
9	74-1880	1	Case-Upper Gear
10	3296-5	1	Nut-Lock Ni
11	39-6660	1	Pinion-Bevel
12	29-9330	2	Key
13	29-9340	1	Collar-Shift
14	42-4740	1	Gear-38 Tooth
15	29-9271	1	Gear-42 Tooth
16	60-8870	1	Yoke-Shift
17	29-9570	1	Bushing-Yoke
18	47-6730	2	Seal-Oil
19	55-8010	1	Sleeve-Gear
20	39-6720	1	Sleeve
21	55-8020	1	Retainer-Key
22	3285-19	1	Pin-Groove
23	47-7270	2	Bearing
24	49-2040	8	Screw-Taptite
25	29-9690	1	Washer
26	46-3560	1	Gear
27	3257-1	2	Key-Woodruff

Ref. No.	Part No.	Qty.	Description
28	48-2060	2	Bearing-Roller
29	36-4770	3	Washer
30	252-103	2	Bearing-Closed
31	36-4792	4	Washer-Thrust
32	39-6650	1	Gear-18t
33	46-3550	1	Gear
34	46-3540	1	Gear
35	74-1760	1	Gear-Bevel
36	53-7950	1	Shaft-Intermediate
37	36-4780	3	Washer
39	39-7842	1	Key
41	47-7260	1	Seal
42	302-63	1	Zerk
44	74-1750-03	1	Brk-Traction Engage
45	3256-45	1	Washer-Flat

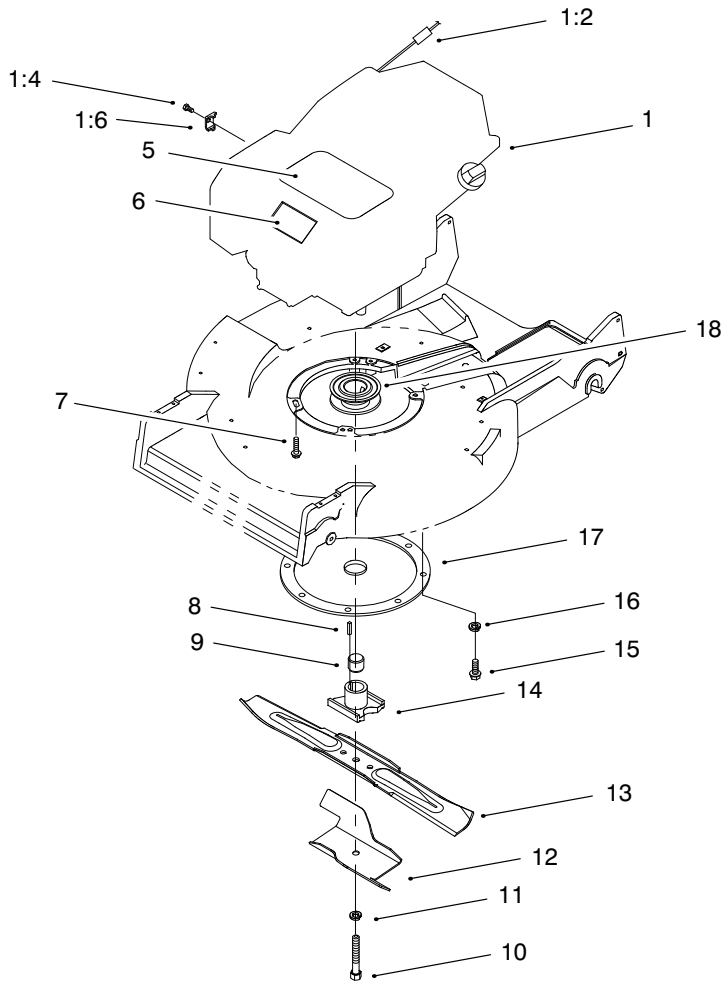

Sheet No.:3

Engine Assembly

Ref. No.	Part No.	Qty.	Description	Ref. No.	Part No.	Qty.	Description
1		1	ASM – Engine Replacement				
1:2	2210-316	1	Stop-Rope				
1:4	93-8470	1	Screw-Clamp				
1:6	2210-249	1	Clamp-Casing				
5	98-2002	1	Decal-Gts 200				
6	84-4960	1	Decal – Proline				
7	32144-102	3	Screw-HWH				
8	27-6300	1	Key-Square				
9	52-2190	1	Spacer-Blade Ret				
10	26-0670	1	Screw-Blade				
11	3253-22	1	Washer-Lock/Sp				
12	92-1599-03	1	Stiffener-Blade				
13	14-9419	1	Blade				
14	52-2170	1	Blade Retainer Wa				
15	32144-70	3	Screw-HH				
16	3254-6	3	Washer-Lock/Int				
17	65-5860	1	Crankshaft Protector As				
18	46-7910	1	Pulley-Driver				

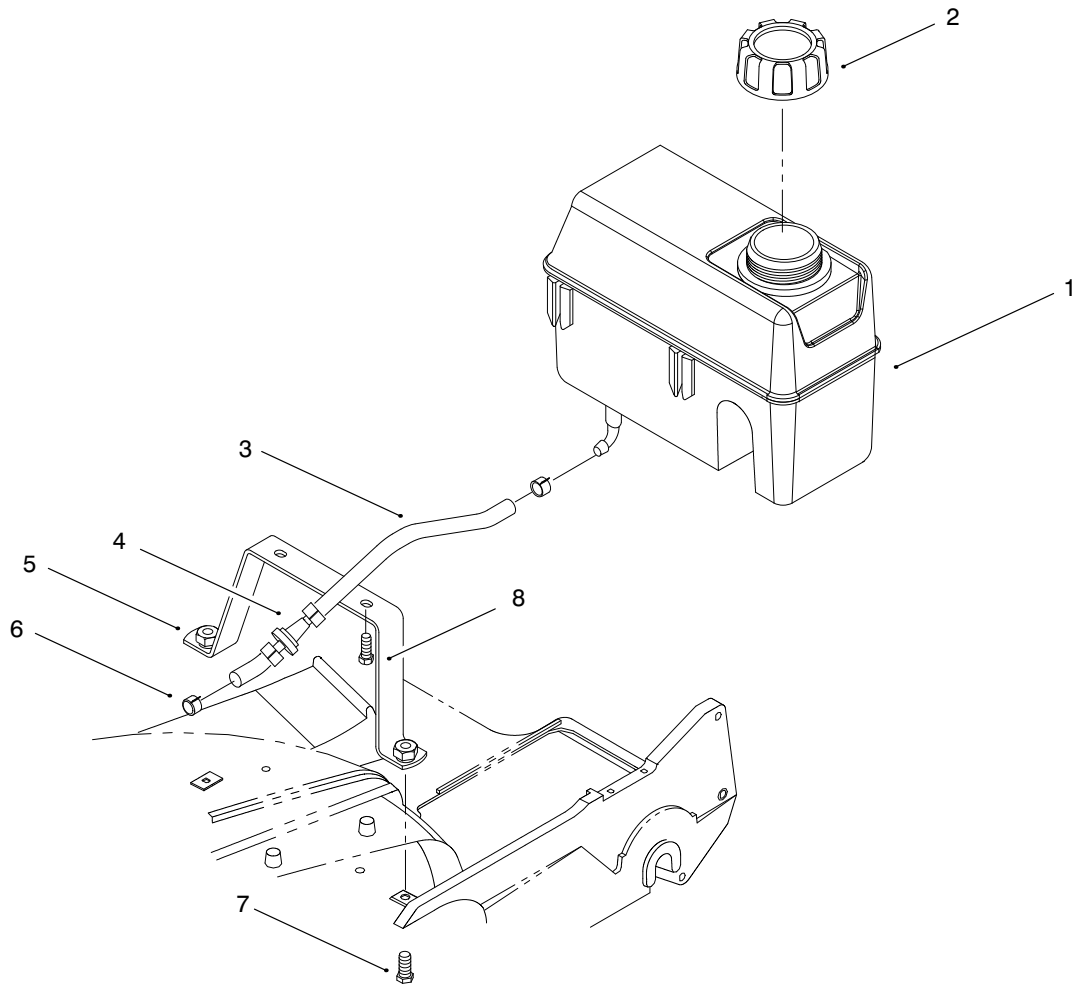

Sheet No.:4

Gas Tank Assembly

Ref. No.	Part No.	Qty.	Description
1	93-3166	1	Tank – Fuel
2	55-3570	1	Gas Cap Assembly
3	51-3210	2	Line–Fuel 5.68
4	71-9280	1	Filter–Fuel
5	84-9170-03	1	Tank Base Wa
6	2412-95	4	Clamp–Fuel Line
7	95-1727	2	Screw–Taptite w/Patch
8	46-8091	2	Special–HWH

Ref. No.	Part No.	Qty.	Description

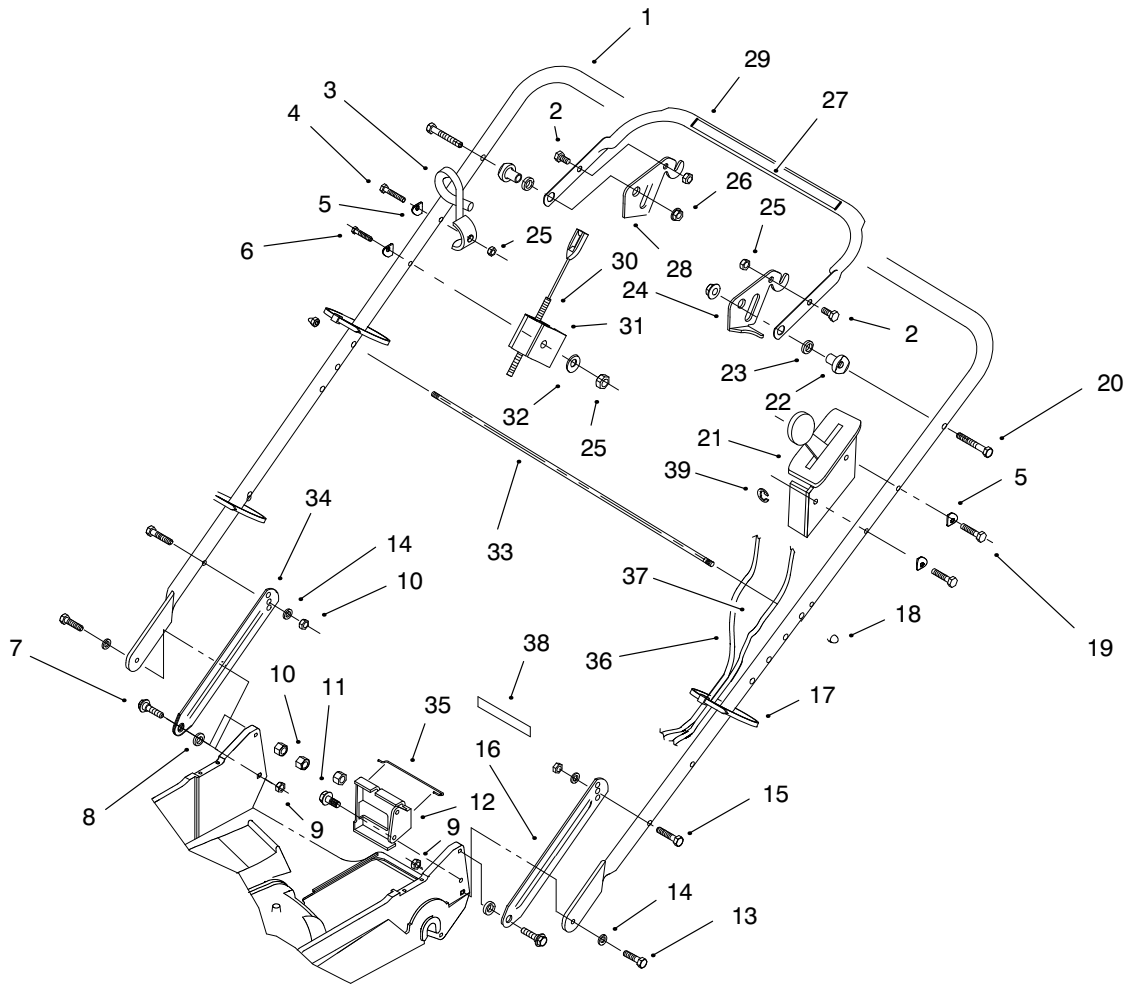

Sheet No.:5

Handle Assembly

Ref. No.	Part No.	Qty.	Description
1	98-2000-03	1	Handle
2	321-4	2	Screw-HH
3	46-8081	1	Guide-Rope
4	321-9	1	Screw-HH
5	3-7501	4	Washer
6	321-15	1	Screw-HH
7	27-7210	2	Screw-Shoulder
8	3-3287	2	Spacer-Handle Latch
9	3296-47	2	Nut-Lock Ni
10	3296-29	4	Nut-Lock
11	32144-70	1	Screw-HH
12	74-1741-03	1	Brkt-Traction Adj.
13	322-6	2	Screw-HH
14	3290-456	4	Washer-Belleville
15	322-7	2	Screw-HH
16	100-3298-03	1	Latch-LH Handle
17	3290-378	4	Tie-Cable
18	32111-7	2	Nut-Cap
19	321-13	2	Screw-HH
20	322-11	2	Screw-HH
21	98-2001	1	Brkt-Throttle Cont'l Head
22	49-1630	2	Spacer-Support
23	256-276	2	Spacer-Nylon
24	66-5350	1	Lever-Control
25	3296-42	4	Nut-Lock

Ref. No.	Part No.	Qty.	Description
26	3296-58	2	Nut-Lock Ni
27	98-7116	1	Decal/Traction Control
28	77-5270	1	Lever-Control
29	61-8270-03	1	Bar-Control
30	93-3661	1	Cable - Brake
31	46-6980	1	Support-Cable
32	3256-22	1	Washer-Flat
33	48-2810	1	Rod-Bag Support
34	100-3297-03	1	Latch-RH Handle
35	46-7030	1	Retainer-Cable
36	74-1791	1	Cable-Traction
37	98-2047	1	Cable - Throttle
38	74-1970	1	Decal - Gear Position
39	32151-86	2	E-Ring - Throt & Tract

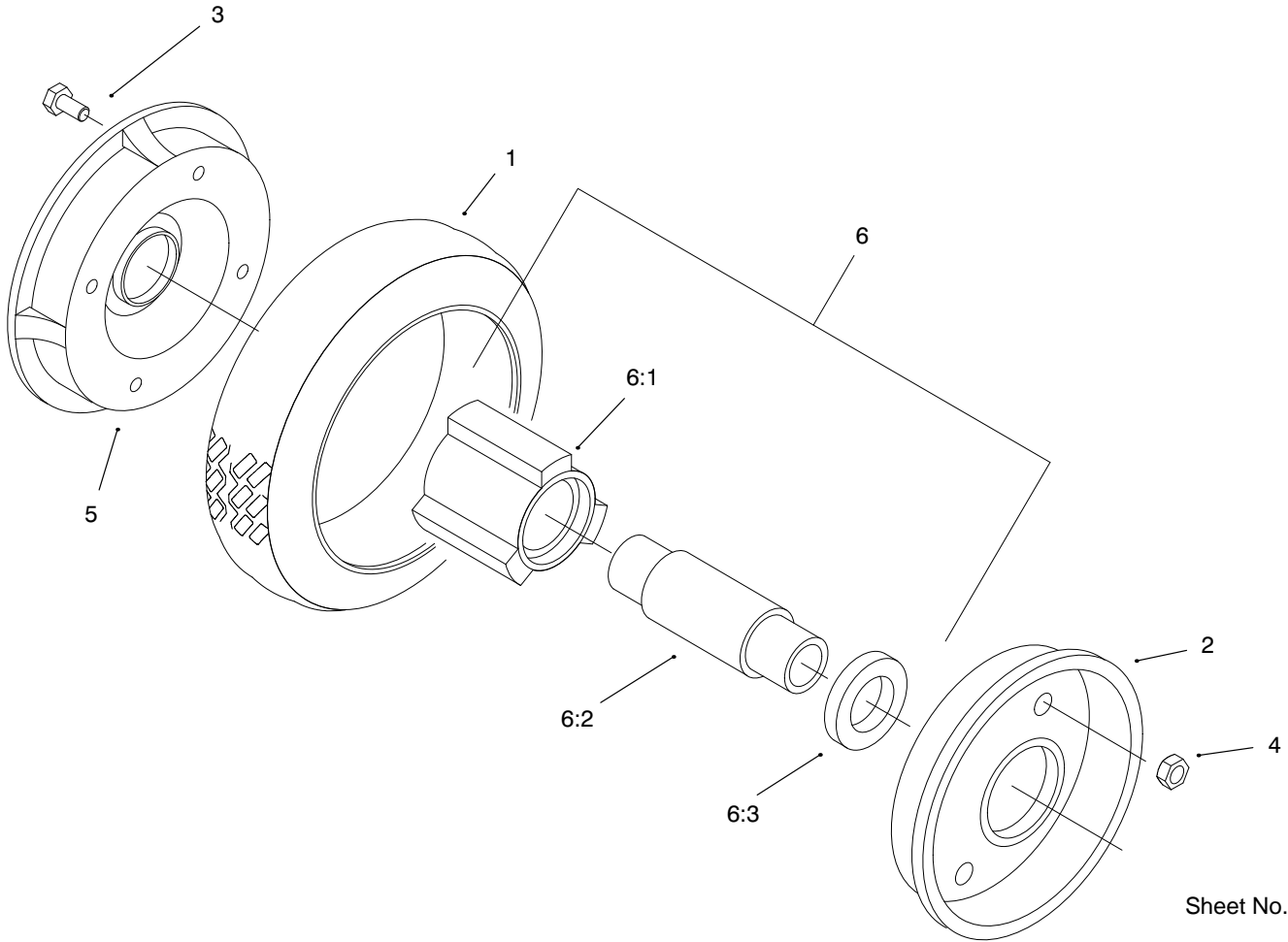

Sheet No.:A3

Rear Wheel & Tire Assembly

Ref. No.	Part No.	Qty.	Description
1	53-7740	1	Tire
2	53-7780-06	1	Plate-Wheel Half
3	321-2	4	Screw-HH
4	3296-42	4	Nut-Lock
5	92-4957-06	1	Wheel Half/Gear ASM
6		1	Hub & Brg ASM
6:1	52-2410	1	Hub-Bearing Supt
6:2	52-2440	1	Spacer-Bearing
6:3	52-2450	2	Bearing-Wheel

Ref. No.	Part No.	Qty.	Description

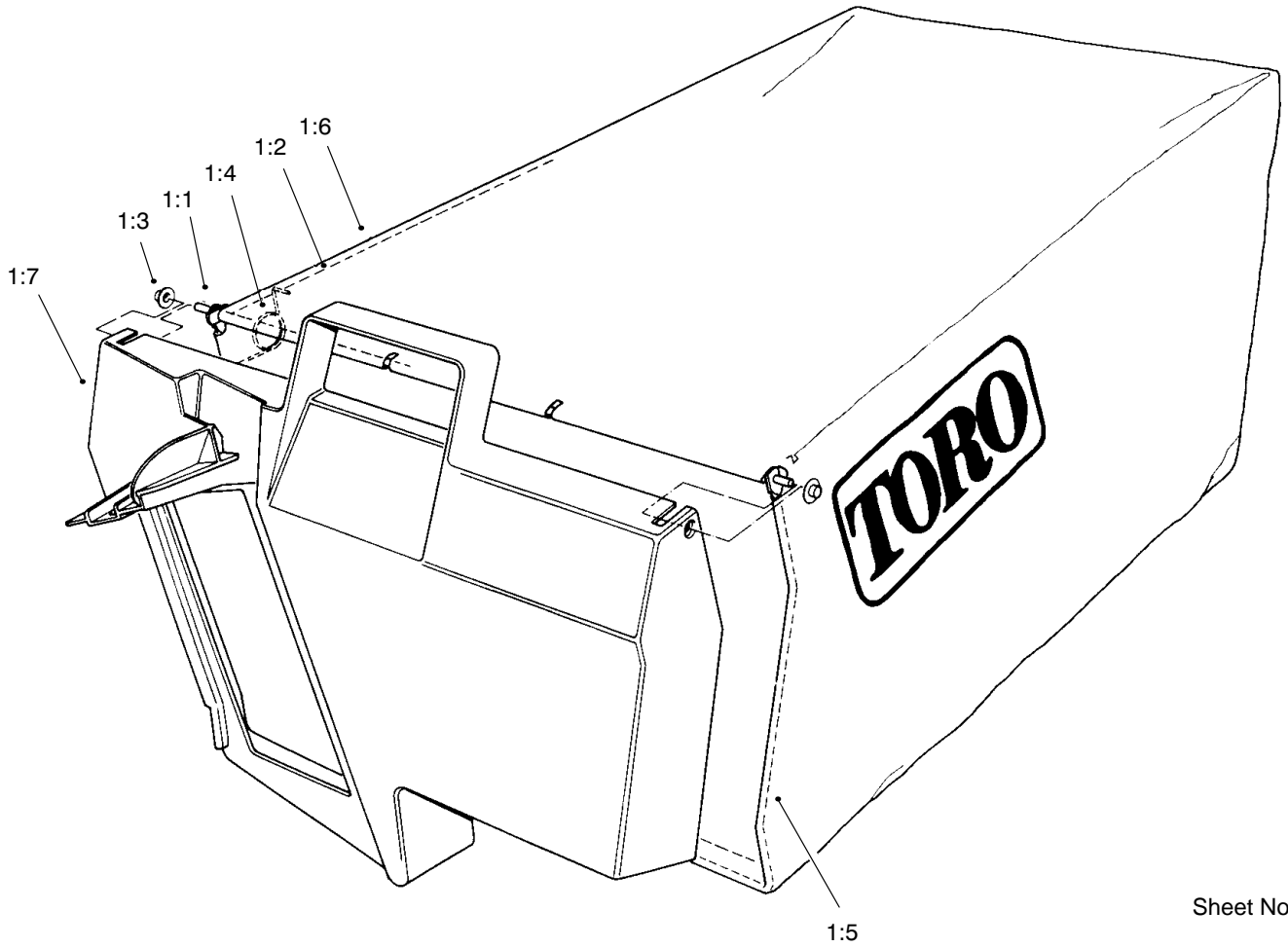

Sheet No.:A4

Grass Bagging Assembly

Ref. No.	Part No.	Qty.	Description
1		1	Grass Bag Assembly
1:1	33-4820	1	Hinge-Bag Door
1:2	42-4030	1	Frame-Upper Bag
1:3	3290-422	2	Nut-Push
1:4	36-6910	2	Spring
1:5	42-4020	1	Frame-Bag
1:6	98-9222	1	ASM - Grass Bag
1:7	48-2840	1	Door-grass Bag

Ref. No.	Part No.	Qty.	Description

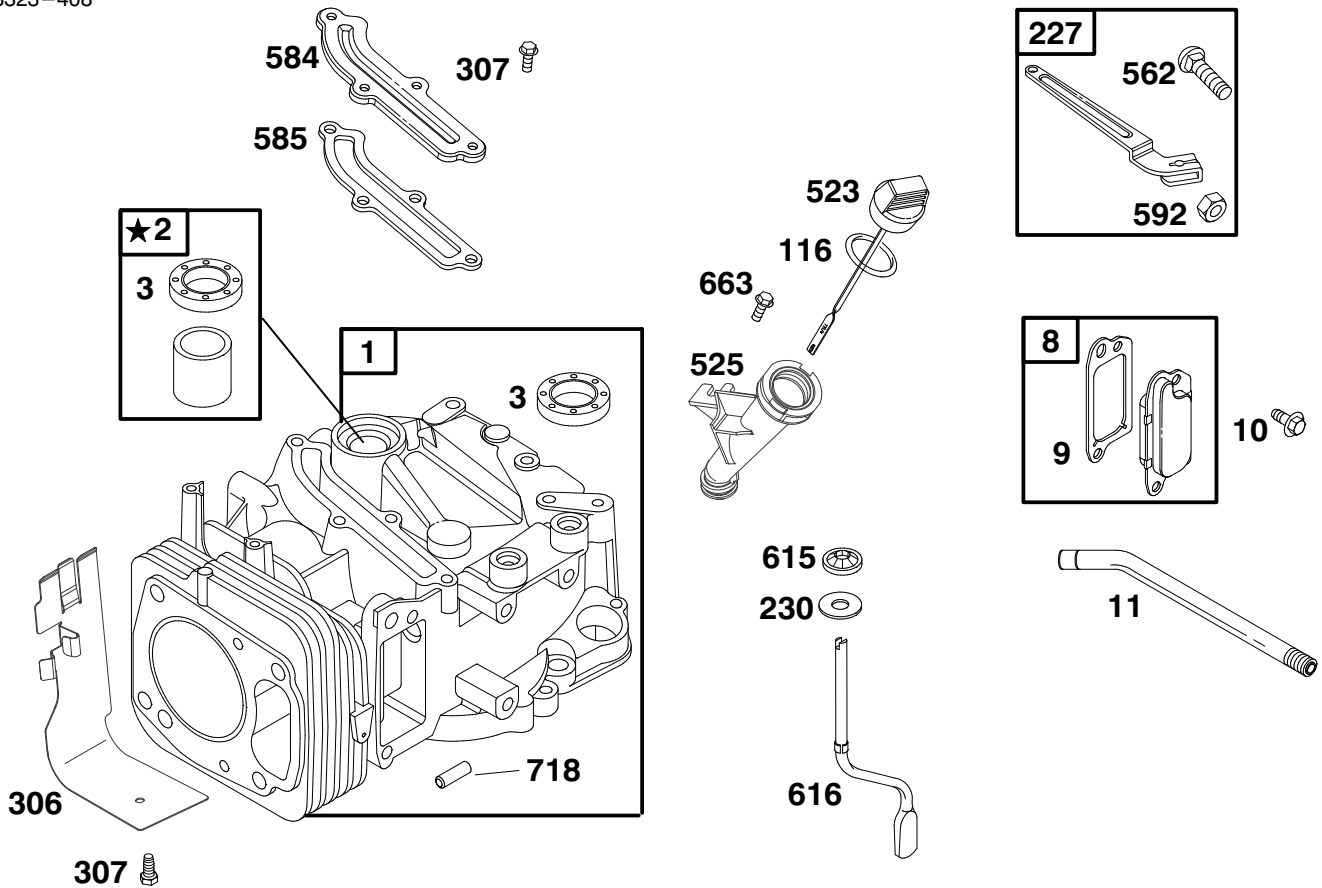

★ **REQUIRES SPECIAL TOOLS TO INSTALL. SEE REPAIR INSTRUCTION MANUAL.**

Assemblies include all parts shown in frames.

ENGINE GTS-200

Ref. No.	Part No.	Description	No. Used
1	99-0900	Cylinder Assembly	1
2	99-0911	Bushing	1
★3	99-0912	Seal - Oil	1
8	77-9260	Breather Assy.	1
†★9	99-0913	Gasket - Breather	1
10	99-0914	Screw - Hex.	1
11	99-0915	Tube - Breather	1
★116	99-0916	Seal - O Ring	1
227	99-0917	Lever Assembly - Gov.	1
230	99-0918	Washer - Gov. Crank	1
306	99-0919	Shield - Cylinder	1

Ref. No.	Part No.	Description	No. Used
307	99-0920	Screw - Hex.	1
523	77-7260	Dipstick	1
525	99-0906	Tube - Oil Filler	1
562	99-0921	Screw - Hex.	1
584	99-0922	Baffle - Cylinder	1
★585	99-0923	Gasket - Breather	1
592	99-0924	Nut - Hex.	1
615	99-0925	Fastener	1
616	99-0926	Crank - Governor	1
663	99-0927	Screw - Hex.	1
718	99-0928	Dowel - Sleeve	1

★ Included in Gasket Set - Part No. 99-0902

† Included in Valve Overhaul Gasket Set - Part No. 99-0904

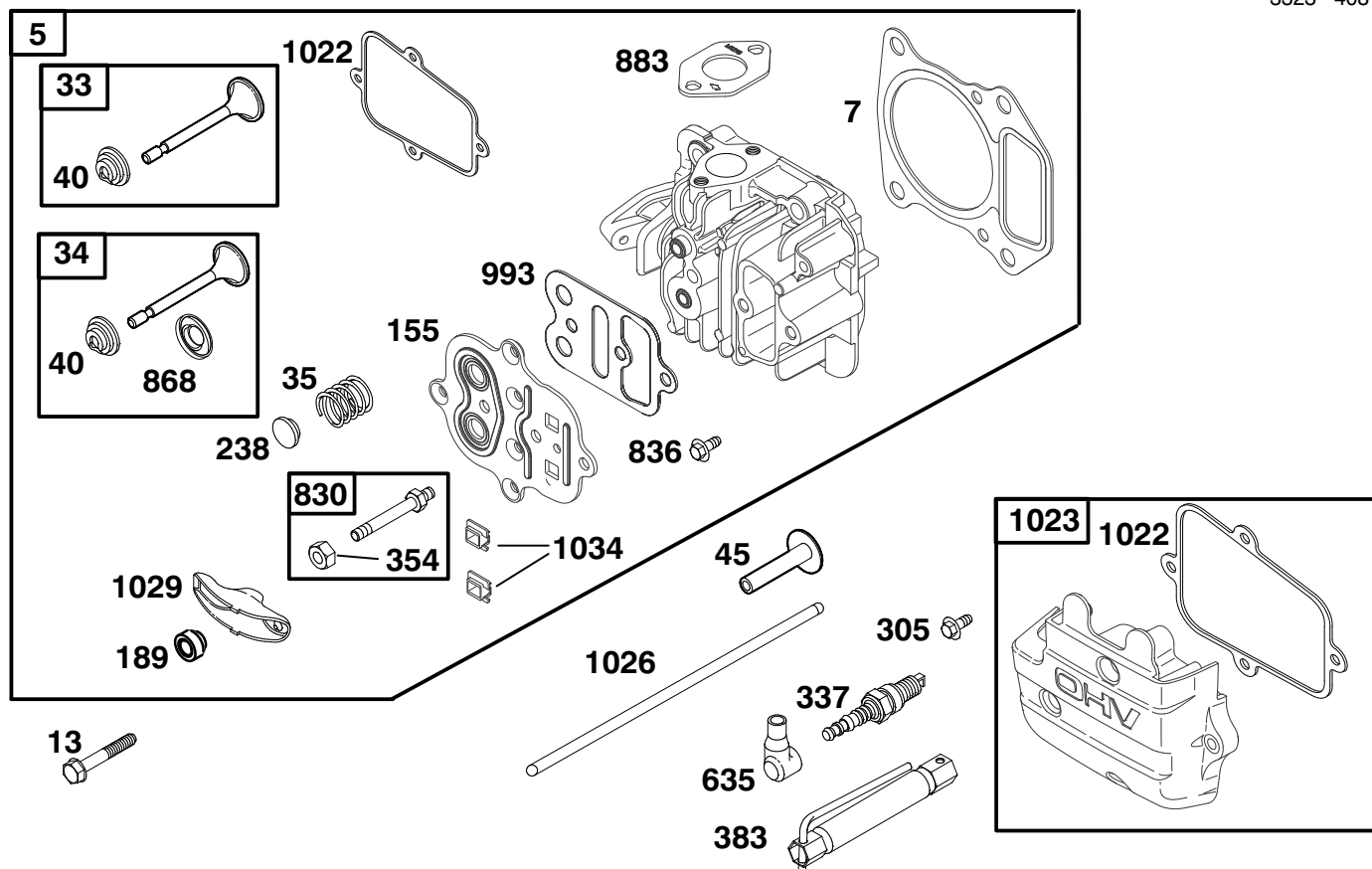

Assemblies include all parts shown in frames.

ENGINE GTS-200

Ref. No.	Part No.	Description	No. Used
5	99-0929	Head - Cylinder	1
†★7	99-0930	Gasket - Cylinder Head	1
13	99-0931	Screw - Hex.	1
33	99-0932	Valve - Exhaust	1
34	99-0933	Valve - Intake	1
35	99-0934	Spring - Valve	1
40	99-0935	Retainer - Valve Spring	1
45	99-0936	Tappet - Valve	1
155	99-0938	Plate - Cylinder Head	1
189	99-0939	Ball - Rocker Arm	1
238	99-0940	Cap - Valve	1
305	99-0942	Screw - Hex.	1
337	99-0943	Plug - Spark	1
354		Nut - Hex. (Sold in Kit Only).	1

Ref. No.	Part No.	Description	No. Used
383	99-0944	Wrench - Spark Plug	1
635	77-9190	Elbow - Spark Plug	1
830	99-0945	Stud - Rocker Arm	1
836	99-0941	Screw - Hex.	1
†★868	99-0946	Seal - Valve	1
†★883	99-0947	Gasket - Exhaust	1
†★993	99-0948	Gasket - Plate	1
†★1022	99-0907	Gasket - Rocker Cover	1
1023	98-9211	Cover - Rocker	1
1026	99-0949	Rod - Push	1
1029	99-0950	Arm - Rocker	1
1034	99-0951	Guide - Push Rod	1

★ Included in Gasket Set - Part No. 99-0902

† Included in Valve Overhaul Gasket Set - Part No. 99-0904

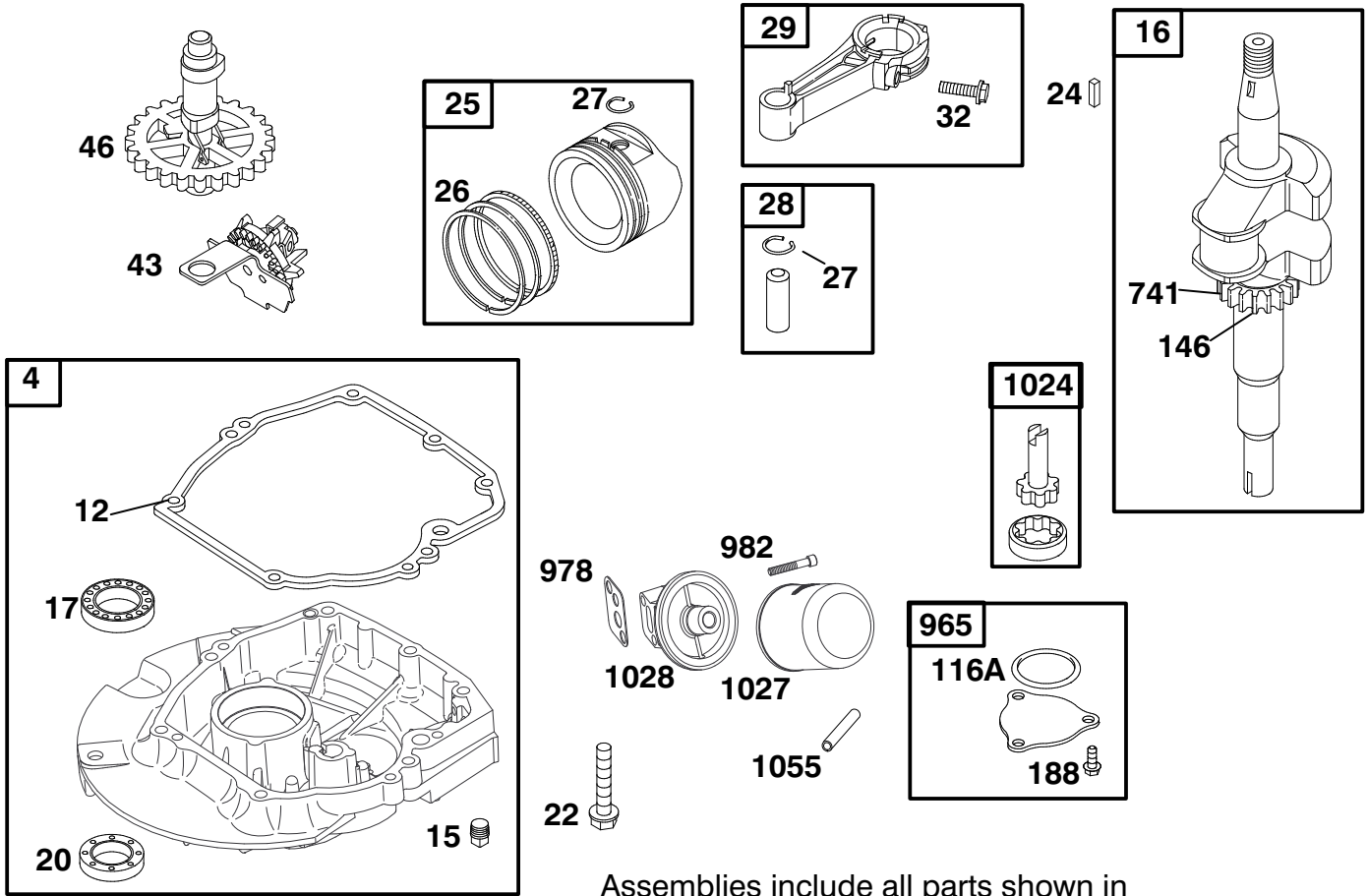

Assemblies include all parts shown in frames.

ENGINE GTS-200

Ref. No.	Part No.	Description	No. Used
4	99-0980	Sump - Engine	1
★12	99-0953	Gasket - Crankcase	1
15	99-0954	Plug - Oil Drain	1
16	98-9214	Crankshaft	1
17	99-1031	Bearing - Ball	1
★20	99-0955	Seal - Oil	1
22	99-0956	Screw - Hex.	1
		Note: 99-1040	
		Screw - Hex.	1
		(One (1) Used in Hole Nearest Breather)	
24	99-0957	Key - Flywheel	1
25	99-0958	Piston Assy. (Standard)	1
26	99-0959	Ring Set (Standard)	1
27	99-0960	Lock - Piston Pin	1
28	99-0961	Pin - Piston (Standard)	1

Ref. No.	Part No.	Description	No. Used
29	99-0962	Rod - Connecting	1
32	99-0963	Screw - Connecting Rod	1
43	99-0937	Governor/Oil Slinger	1
46	99-0965	Gear - Cam	1
116A	99-1032	Seal - O-Ring	1
146	99-0966	Key - Timing	1
188	99-1033	Screw - Hex.	1
741	99-0967	Gear - Timing	1
965	99-1034	Cover - Oil Pump	1
978	99-1035	Gasket - Adapter	1
982	99-1036	Screw - Soc. Hd.	1
1024	99-1037	Pump - Oil	1
1027	98-9217	Filter - Oil	1
1028	99-1038	Adapter - Oil Filter	1
1055	99-1039	Tube - Oil Pump	1

★ Included in Gasket Set - Part No. 99-0902

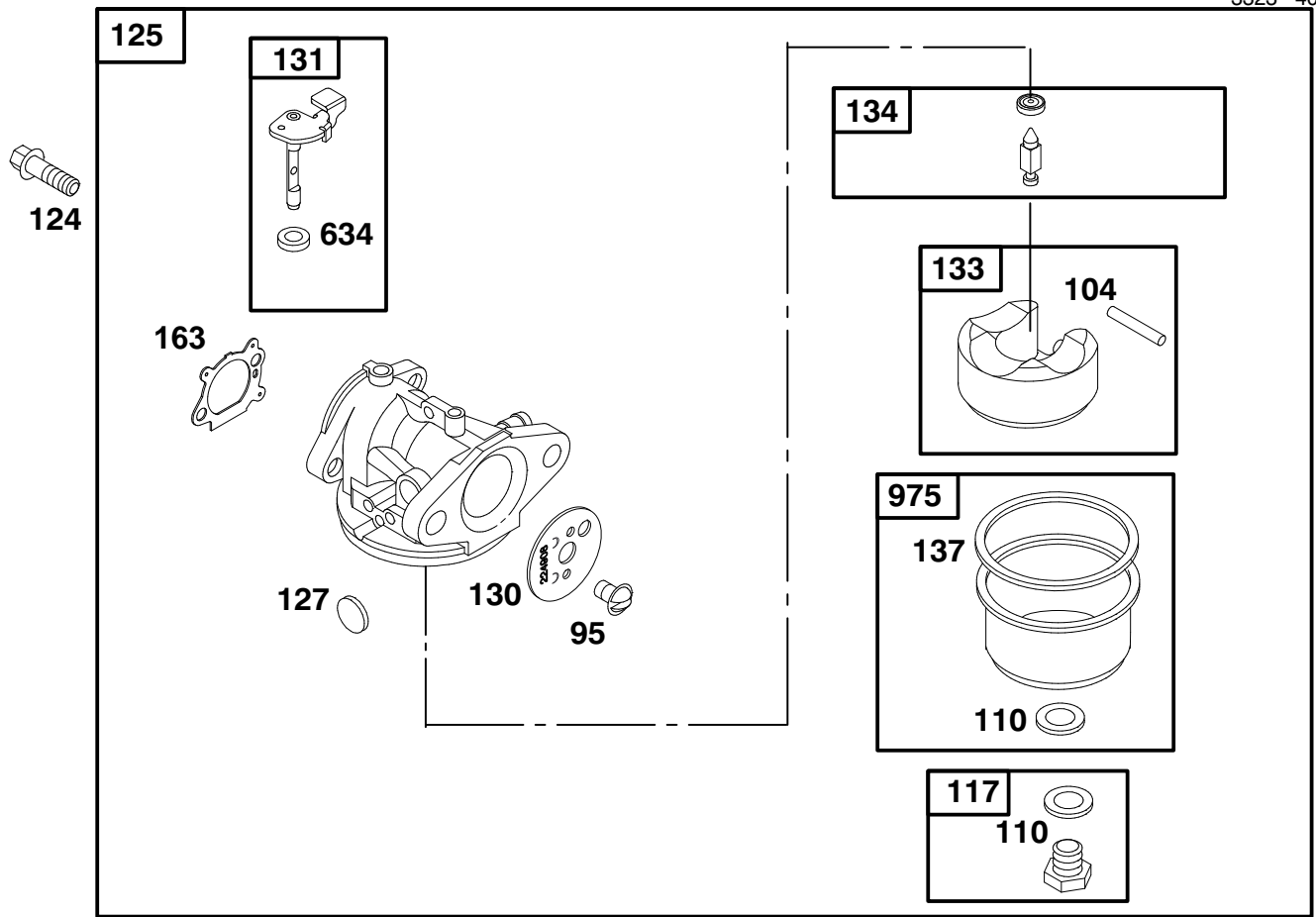

Assemblies include all parts shown in frames.

ENGINE GTS-200

Ref. No.	Part No.	Description	No. Used
95	99-0969	Screw - Slotted	1
●104	99-0970	Pin - Float Hinge	1
◆110		Washer - Bowl (Sold in Kit Only)	1
117	99-0971	Jet - Main (Std.) Note: 99-1041 Jet - Main (High Altitude)	1
124	99-0972	Screw - Shoulder	1
125	99-0973	Carburetor	1
●127		Plug - Welch (Sold in Kit Only).	1

Ref. No.	Part No.	Description	No. Used
130	99-0974	Valve - Throttle	1
131	99-0975	Shaft - Throttle	1
133	77-8170	Float - Carburetor	1
●134	77-8110	Valve - Needle	1
◆137		Gasket - Bowl (Sold in Kit Only).	1
◆★163	99-0976	Gasket - Air Cleaner	1
◆◆634		Washer - Foam (Sold in Kit Only).	1
975	99-0977	Bowl - Float	1

● Included in Carburetor Kit - Part No. 99-0901

◆ Included in Carburetor Gasket Set - Part No. 99-0903

★ Included in Gasket Set - Part No. 99-0902

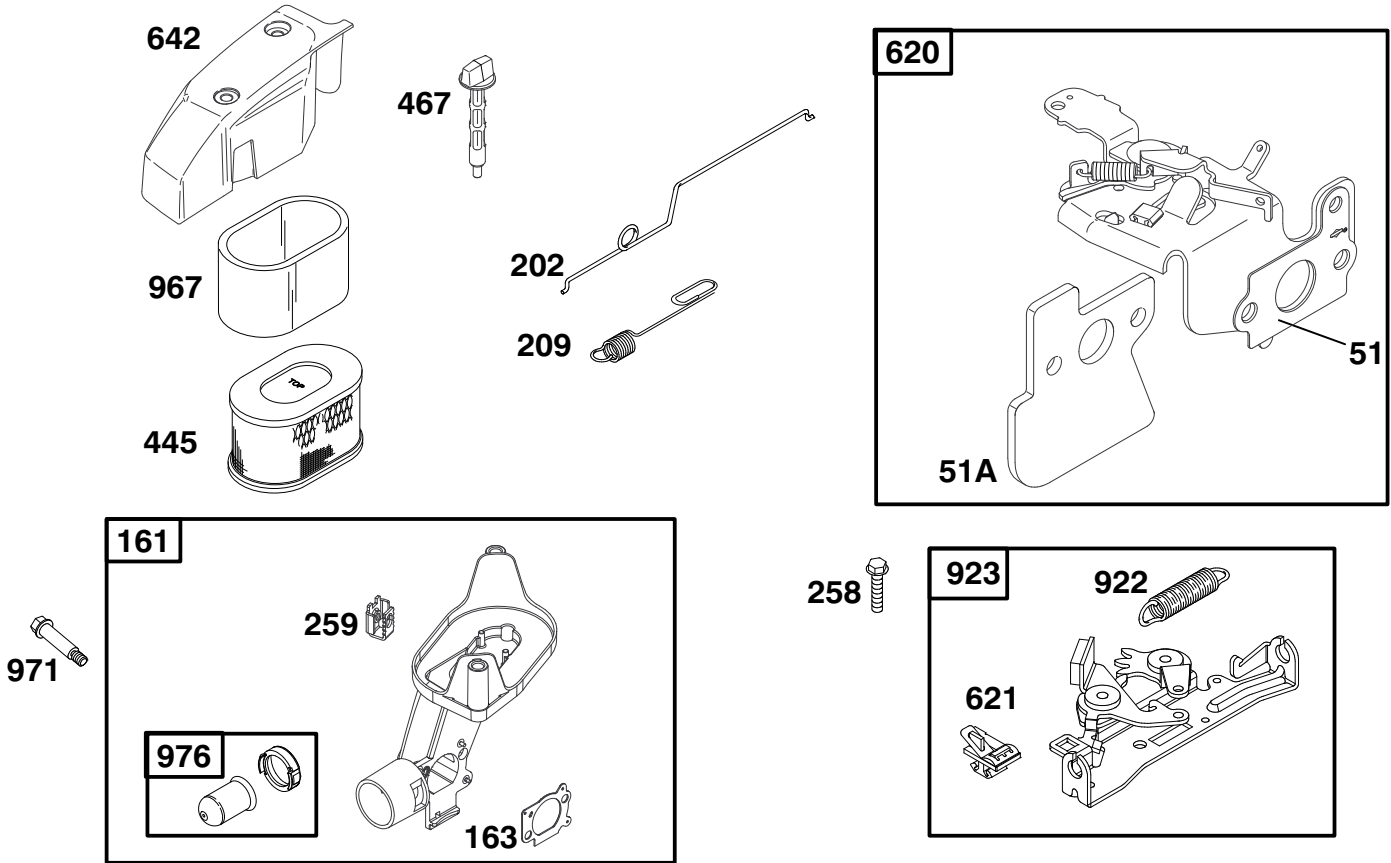

Assemblies include all parts shown in frames.

ENGINE GTS-200

Ref. No.	Part No.	Description	No. Used
51	99-0968	Gasket - Intake	1
51A	99-0978	Gasket - Intake	1
161	99-0979	Base - Air Cleaner/Primer	1
◆★163	99-0976	Gasket - Air Cleaner	1
202	99-0981	Link - Governor	1
209	99-0982	Spring - Governor	1
258	99-0983	Screw - Hex.	1
259	99-0984	Grommet	1
445	98-9212	Filter - Air	1

Ref. No.	Part No.	Description	No. Used
467	98-9208	Knob	1
620	99-0985	Bracket - Control	1
621	99-0986	Switch - Stop	1
642	98-9207	Cover - Air Cleaner	1
922	99-0987	Spring - Brake	1
923	99-0988	Brake Assembly	1
967	99-0989	Filter - Air	1
971	99-0990	Screw - Hex.	1
976	99-0991	Primer - Carburetor	1

● Included in Carburetor Kit - Part No. 99-0901

◆ Included in Carburetor Gasket Set - Part No. 99-0903

★ Included in Gasket Set - Part No. 99-0902

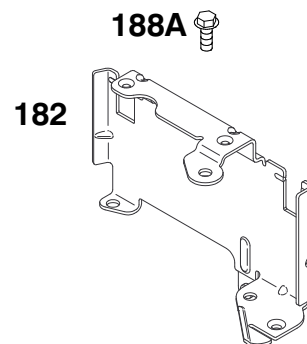
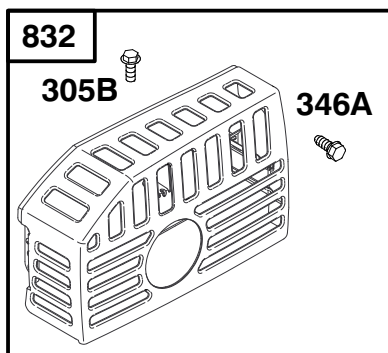
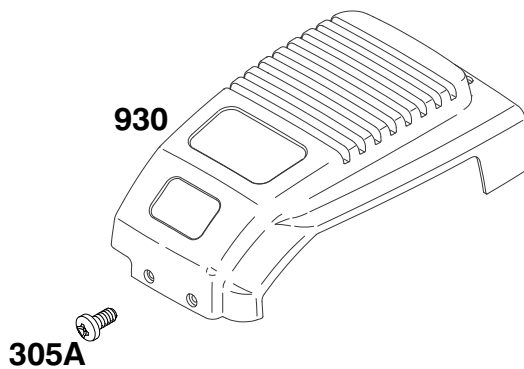
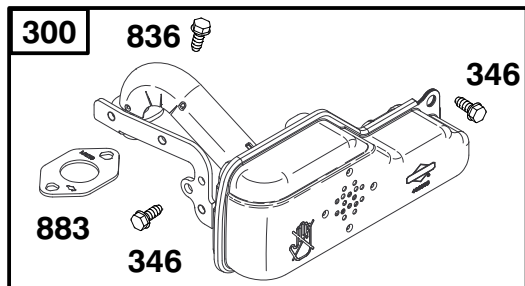

Assemblies include all parts shown in frames.

ENGINE GTS-200

Ref. No.	Part No.	Description	No. Used
182	98-9205	Bracket - Tank Mounting	1
188A	98-9202	Screw - Hex.	1
300	99-0995	Muffler - Exhaust	1
305A	98-9204	Screw - Hex.	1
305B	99-0998	Screw - Hex.	1
346	99-1047	Screw - Hex.	1

Ref. No.	Part No.	Description	No. Used
346A	99-0999	Screw - Hex.	1
832	98-9206	Guard - Muffler	1
836	99-0941	Screw - Hex.	1
†★883	99-0947	Gasket - Exhaust	1
930	98-9203	Guard - Rewind	1

★ Included in Gasket Set - Part No. 99-0902

† Included in Valve Overhaul Gasket Set - Part No. 99-0904

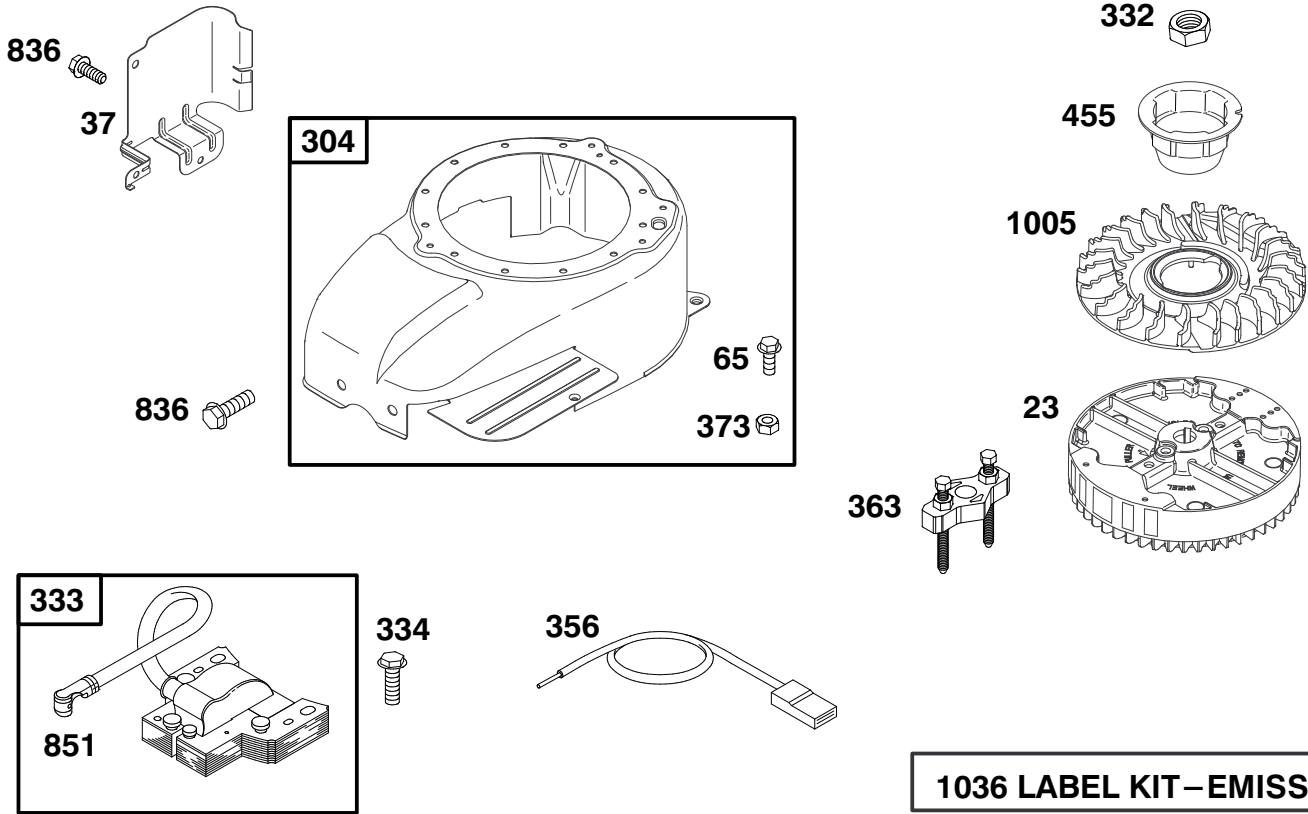

Assemblies include all parts shown in frames.

ENGINE GTS-200

Ref. No.	Part No.	Description	No. Used
23	99-1001	Flywheel	1
37	99-1013	Guard - Flywheel	1
65	99-1002	Screw - Hex.	1
304	99-1003	Housing - Blower	1
332	99-1004	Nut - Flywheel	1
333	99-1005	Armature - Magneto	1
334	99-1006	Screw - Hex.	1
356	99-1007	Wire - Stop	1

Ref. No.	Part No.	Description	No. Used
363	99-1008	Puller - Flywheel	1
373	99-1009	Nut - Hex.	1
455	99-1010	Cup - Flywheel	1
836	99-0941	Screw - Hex.	1
851	77-9450	Terminal - Cable	1
1005	99-1015	Fan - Flywheel	1
1036	99-1016	Label Kit - Emission	1

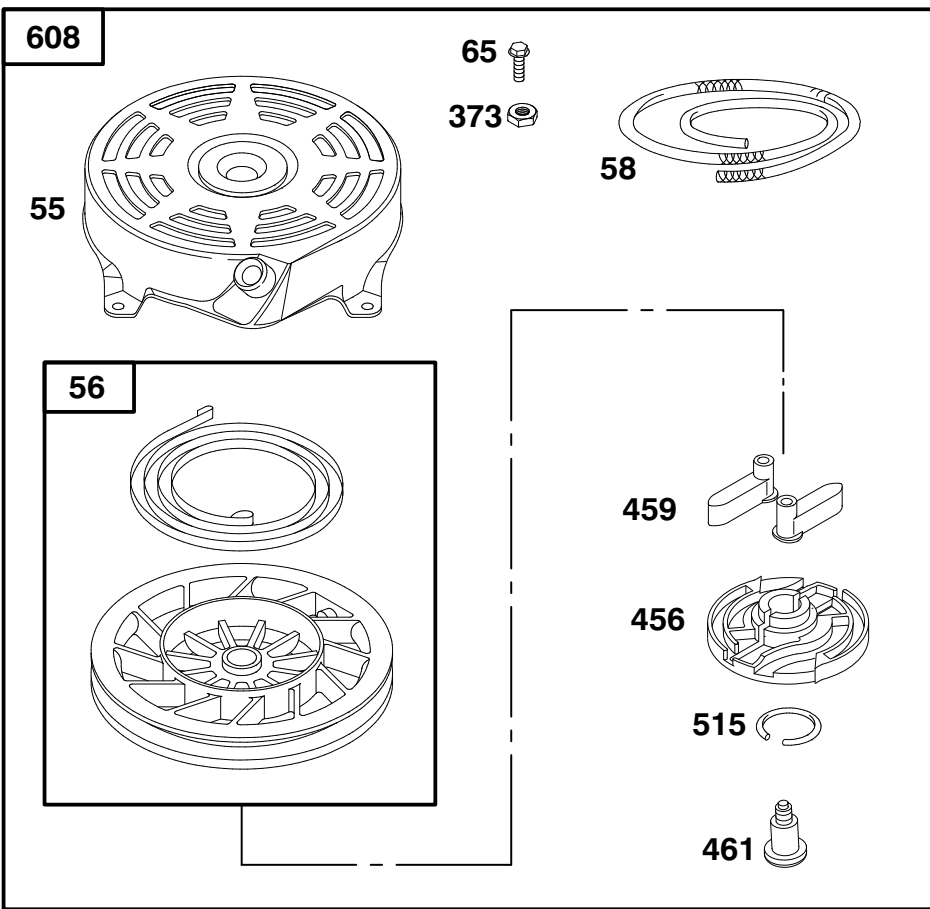

Assemblies include all parts shown in frames.

ENGINE GTS-200

Ref. No.	Part No.	Description	No. Used
55	99-1048	Housing - Rewind Starter	1
56	94-1657	Pulley - Starter	1
58	94-1668	Rope - Starter	1
59	77-7210	Insert - Starter Grip	1
60	77-8520	Grip - Starter Rope	1
65	99-1002	Screw - Hex.	1

Ref. No.	Part No.	Description	No. Used
373	99-1009	Nut - Hex.	1
456	94-1659	Retainer - Spring	1
459	94-1654	Pawl - Ratchet	1
461	94-1600	Screw - Shoulder	1
515	94-1655	Spring - Friction	1
608	98-9215	Starter - Rewind	1

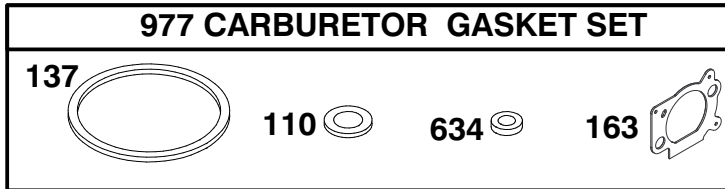
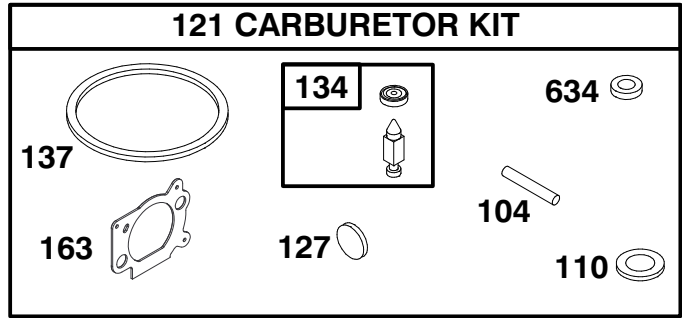
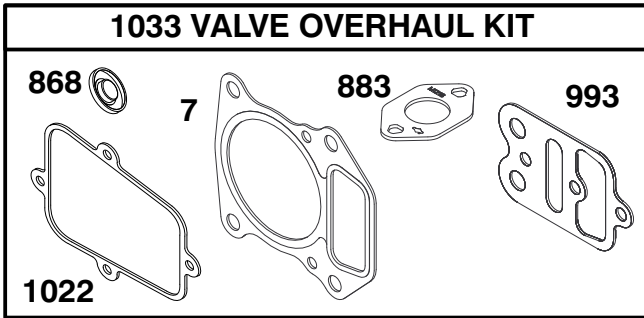
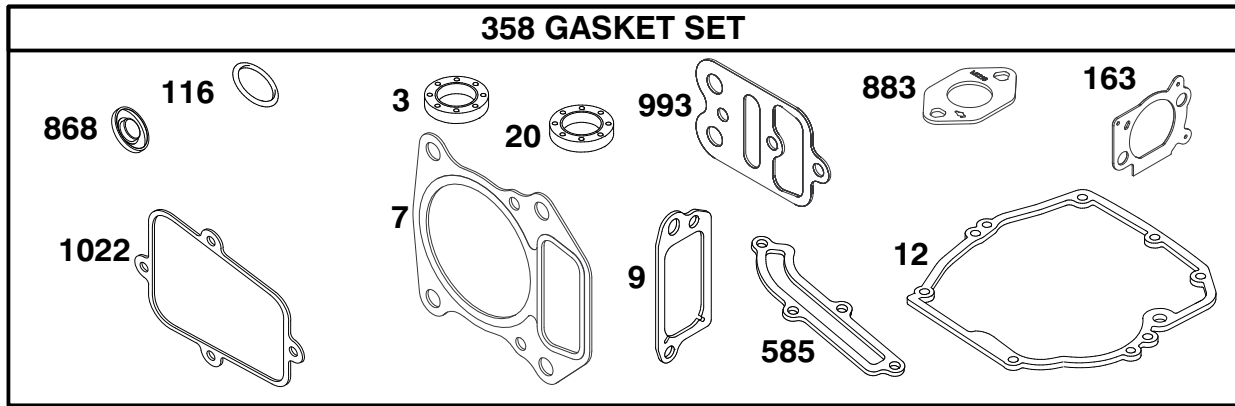

Assemblies include all parts shown in frames.

ENGINE GTS-200

Ref. No.	Part No.	Description	No. Used
★3	99-0912	Seal - Oil	1
†★7	99-0930	Gasket - Cylinder Head	1
†★9	99-0913	Gasket - Breather	1
★12	99-0953	Gasket - Crankcase	1
★20	99-0955	Seal - Oil	1
●104	99-0970	Pin - Float Hinge	1
●◆110		Washer - Bowl (Sold in Kit Only).	1
★116	99-0916	Seal - O Ring	1
121	99-0901	Carburetor Kit	1
●127		Plug - Welch (Sold in Kit Only).	1
●134	77-8110	Valve - Needle	1
●◆137		Gasket - Bowl (Sold in Kit Only).	1

Ref. No.	Part No.	Description	No. Used
●◆★163	99-0976	Gasket - Air Cleaner	1
358	99-0902	Gasket Set	1
★585	99-0923	Gasket - Breather	1
●◆634		Washer - Foam (Sold in Kit Only).	1
†★868	99-0946	Seal - Valve	1
†★883	99-0947	Gasket - Exhaust	1
977	99-0903	Gasket Set - Carburetor	1
†★993	99-0948	Gasket - Plate	1
†★1022	99-0907	Gasket - Rocker Cover	1
1033	99-0904	Gasket Set - Valve Overhaul	1

★ Included in Gasket Set - Part No. 99-0902

† Included in Valve Overhaul Gasket Set - Part No. 99-0904

◆ Included in Carburetor Gasket Set - Part No. 99-0903

● Included in Carburetor Kit - Part No. 99-0901

