



**Z-Master<sup>®</sup> Z253**  
**with 62" Side Discharge Mower**  
Model No. 74209-20000001 & Up

**Operator's Manual**

# Introduction

Thank you for purchasing a Toro product.

All of us at Toro want you to be completely satisfied with your new product, so feel free to contact your local Authorized Service Dealer for help with service, genuine replacement parts, or other information you may require.

Whenever you contact your Authorized Service Dealer or the factory, always know the model and serial numbers of your product. These numbers will help the Service Dealer or Service Representative provide exact information about your specific product. You will find the model and serial number plate located in a unique place on the product as shown below.

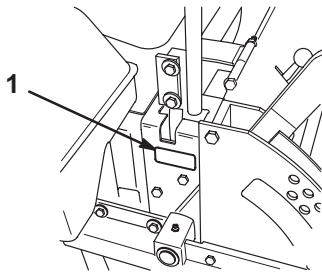

1. Model and Serial Number Plate

For your convenience, write the product model and serial numbers in the space below.

<b>Model No:</b> _____
<b>Serial No.</b> _____

Read this manual carefully to learn how to operate and maintain your product correctly. Reading this manual will help you and others avoid personal injury and damage to the product. Although we design, produce and market safe, state-of-the-art products, you are responsible for using the product properly and safely. You are also responsible for training persons, who you allow to use the product, about safe operation.

The warning system in this manual identifies potential hazards and has special safety messages that help you and others avoid personal injury, even death. DANGER, WARNING and CAUTION are signal words used to identify the level of hazard. However, regardless of the hazard, be extremely careful.



**DANGER** signals an extreme hazard that will cause serious injury or death if the recommended precautions are not followed.

**WARNING** signals a hazard that may cause serious injury or death if the recommended precautions are not followed.

**CAUTION** signals a hazard that may cause minor or moderate injury if the recommended precautions are not followed.

Two other words are also used to highlight information. “Important” calls attention to special mechanical information and “Note” emphasizes general information worthy of special attention.

The left and right side of the machine is determined from the normal operator’s position.

 <b>WARNING:</b> 
<b>The engine exhaust from this product contains chemicals known to the State of California to cause cancer, birth defects, or other reproductive harm.</b>

**IMPORTANT:** This engine is not equipped with a spark arrester muffler. It is a violation of California Public Resource Code Section 4442 to use or operate this engine on any forest-covered, brush-covered or grass-covered land. Other states or federal areas may have similar laws.

# Contents

	<b>Page</b>		<b>Page</b>
Safety	3	Fuel Tanks	29
Safe Operating Practices	3	Adjusting Height-of-Cut	30
Toro Mower Safety	5	Adjusting Anti-Scalp Rollers	30
Slope Chart	9	Positioning the Seat	31
Safety and Instruction Decals	11	Pushing the Machine by Hand	31
Gasoline and Oil	15	Transporting Machines	32
Recommended Gasoline	15	Loading Machines	32
Using Stabilizer/Conditioner	16	Tips for Mowing Grass	34
Filling the Fuel Tank	16	Maintenance	35
Check Engine Oil Level	16	Service Interval Chart	35
Assembly	17	Cutting Blades	36
Loose Parts	17	Air Cleaner	39
Install Drive Wheels	18	Engine Oil	41
Tire Pressure	18	Spark Plug	43
Install Seat Retaining Rod	18	Fuel Filter	44
Install Motion Control Levers	19	Fuel Tank	44
Check Side Discharge Chute	19	Greasing and Lubrication	45
Check the Leveling of Mower Deck	19	Greasing the Bearings	46
Activate the Battery	20	Cleaning the Cooling Systems	47
Install Battery	21	Tire Pressure	47
Hydraulic System	22	Wheel Hub Slotted Nut	47
Greasing the Bearings	23	Castor Pivot Bearing Adjustment	48
Greasing the Bearings	23	Hydraulic System	48
Check Side Discharge Chute	23	Adjusting Motion Controls	51
Check the Leveling of Mower Deck	23	Replacing the Pump Drive Belt	52
Check Engine Oil Level	23	Adjustment Parking Brake	53
Operation	24	Throttle Lever Adjustment	53
Think Safety First	24	Fuse	54
Controls	24	Battery	54
Parking Brake	24	Mower Leveling	55
Starting and Stopping the Engine	25	Belt Inspection	56
Operating the Power Take Off (PTO)	26	Clean Under Deck	56
The Safety Interlock System	27	Replacing the Deck Belt	57
Driving Forward or Backward	28	Replacing the PTO Drive Belt	57
Stopping the Machine	28	Replacing the Grass Deflector	60
Instruments	29	Waste Disposal	61

Mercury Tilt Switch . . . . .	61	Cleaning and Storage . . . . .	63
Mercury Tilt Switch Disposal . . . . .	61	Troubleshooting . . . . .	64
Wiring Diagram . . . . .	62	Warranty . . . . .	Back Page

**THE ENCLOSED ENGINE OWNER'S MANUAL IS SUPPLIED FOR CALIFORNIA EMISSION CONTROL REGULATION INFORMATION ON EMISSION SYSTEMS, MAINTENANCE AND WARRANTY.**

**KEEP THIS ENGINE OWNER'S MANUAL WITH YOUR UNIT. SHOULD THIS ENGINE OWNER'S MANUAL BECOME DAMAGED OR ILLEGIBLE, REPLACE IMMEDIATELY. REPLACEMENTS MAY BE ORDERED THROUGH THE ENGINE MANUFACTURER.**

# Safety

**This machine meets or exceeds CPSC blade safety requirements for rotary mowers and the B71.4 1999 specifications of the American National Standards Institute, in effect at time of production.**

**Note:** The addition of certain attachments that do not meet American National Standards Institute certification will cause noncertification of this machine.

**Improper use or maintenance by the operator or owner can result in injury. To reduce the potential for injury, comply with these safety instructions and always pay attention to the safety alert ▲ symbol, which means CAUTION, WARNING, or DANGER—“personal safety instruction.” Failure to comply with the instruction may result in personal injury or death.**

## Safe Operating Practices

The following instructions are from ANSI standard B71.4—1999.

### Training

- Read the Operator’s Manual and other training material. If the operator(s) or mechanic(s) can not read English it is the owner’s responsibility to explain this material to them.
- Become familiar with the safe operation of the equipment, operator controls, and safety signs.
- All operators and mechanics should be trained. The owner is responsible for training the users.
- Never let children or untrained people operate or service the equipment. Local regulations may restrict the age of the operator.
- The owner/user can prevent and is responsible for accidents or injuries occurring to himself or herself, other people or property.

### Preparation

- Evaluate the terrain to determine what accessories and attachments are needed to properly and safely perform the job. Only use accessories and attachments approved by the manufacturer.
- Wear appropriate clothing including hard hat, safety glasses and ear protection. Long hair, loose clothing or jewelry may get tangled in moving parts.
- Inspect the area where the equipment is to be used and remove all objects such as rocks, toys and wire which can be thrown by the machine.
- Use extra care when handling gasoline and other fuels. They are flammable and vapors are explosive.
  - Use only an approved container
  - Never remove gas cap or add fuel with engine running. Allow engine to cool before refueling. Do not smoke.
  - Never refuel or drain the machine indoors.
- Check that operator’s presence controls, safety switches and shields are attached and functioning properly. Do not operate unless they are functioning properly.

## Operation

- Never run an engine in an enclosed area.
- Only operate in good light, keeping away from holes and hidden hazards.
- Be sure all drives are in neutral and parking brake is engaged before starting engine. Only start engine from the operator's position. Use seat belts if provided.
- Slow down and use extra care on hillsides. Be sure to travel in the recommended direction on hillsides. Turf conditions can affect the machine's stability. Use caution while operating near drop-offs.
- Slow down and use caution when making turns and when changing directions on slopes.
- Never raise deck with the blades running.
- Never operate with the PTO shield, or other guards not securely in place. Be sure all interlocks are attached, adjusted properly, and functioning properly.
- Never operate with the discharge deflector raised, removed or altered, unless using a grass catcher.
- Do not change the engine governor setting or overspeed the engine.
- Stop on level ground, lower implements, disengage drives, engage parking brake (if provided), shut off engine before leaving the operator's position for any reason including emptying the catchers or unclogging the chute.
- Stop equipment and inspect blades after striking objects or if an abnormal vibration occurs. Make necessary repairs before resuming operations.
- Keep hands and feet away from the cutting units.
- Look behind and down before backing up to be sure of a clear path.
- Never carry passengers and keep pets and bystanders away.
- Slow down and use caution when making turns and crossing roads and sidewalks. Stop blades if not mowing.
- Be aware of the mower discharge direction and do not point it at anyone.
- Do not operate the mower under the influence of alcohol or drugs
- Use care when loading or unloading the machine into a trailer or truck
- Use care when approaching blind corners, shrubs, trees, or other objects that may obscure vision.

## Maintenance and storage

- Disengage drives, lower implement, set parking brake, stop engine and remove key or disconnect spark plug wire. Wait for all movement to stop before adjusting, cleaning or repairing.
- Clean grass and debris from cutting units, drives, mufflers, and engine to help prevent fires. Clean up oil or fuel spillage.
- Let engine cool before storing and do not store near flame.
- Shut off fuel while storing or transporting. Do not store fuel near flames or drain indoors.
- Park machine on level ground. Never allow untrained personnel to service machine.
- Use jack stands to support components when required.
- Carefully release pressure from components with stored energy.
- Disconnect battery or remove spark plug wire before making any repairs. Disconnect the negative terminal first and the positive last. Reconnect positive first and negative last.

- Use care when checking blades. Wrap the blade(s) or wear gloves, and use caution when servicing them. Only replace blades. Never straighten or weld them.
- Keep hands and feet away from moving parts. If possible, do not make adjustments with the engine running.
- Charge batteries in an open well ventilated area, away from spark and flames. Unplug charger before connecting or disconnecting from battery. Wear protective clothing and use insulated tools.
- Keep all parts in good working condition and all hardware tightened. Replace all worn or damaged decals.

## Toro Mower Safety

The following list contains safety information specific to Toro products or other safety information that you must know that is not included in the ANSI standards.

This product is capable of amputating hands and feet and throwing objects. Always follow all safety instructions to avoid serious injury or death.

### WARNING

#### POTENTIAL HAZARD

- **Engine exhaust contains carbon monoxide, which is an odorless, deadly poison.**

#### WHAT CAN HAPPEN

- **Carbon monoxide can kill you and is also known to the State of California to cause birth defects.**

#### HOW TO AVOID THE HAZARD

- **Do not run engine indoors or in an enclosed area.**

This product is designed for cutting and recycling grass or, when equipped with a grass bagger, for catching cut grass. Any use for purposes other than these could prove dangerous to user and bystanders.

**Note:** This engine is not equipped with a spark arrester muffler. It is a violation of California Public Resource Code Section 4442 to use or operate this engine on any forest-covered, brush-covered or grass-covered land. Other states or federal areas may have similar laws.

## General Operation

- Allow only responsible adults who are familiar with the instructions to operate the machine.
- Be sure the area is clear of other people before mowing. Stop the machine if anyone enters the area.
- Do not mow in reverse unless absolutely necessary. Always look down and behind before and while backing.
- Be aware of the mower discharge direction and do not point it at anyone. Do not operate the mower without either the entire grass catcher or the guard in place.
- Slow down before turning. Sharp turns on any terrain may cause loss of control.
- Turn off blades when not mowing.
- Keep hands, feet, hair and loose clothing away from attachment discharge area, underside of mower and any moving parts while engine is running.
- Stop the engine before removing the grass catcher or unclogging the chute.
- Mow only in daylight or good artificial light.
- Watch for traffic when operating near or crossing roadways.
- Do not touch equipment or attachment parts which may be hot from operation. Allow to cool before attempting to maintain, adjust or service.

- Before operating a machine with ROPS (roll over protection) be certain the seat belts are attached to prevent the seat from pivoting forward.

### Slope Operation

Slopes and ramps are a major factor related to loss-of-control and tip-over accidents, which can result in severe injury or death. All slopes and ramps require extra caution. If you cannot back up the slope or if you feel uneasy on it, do not mow it.

#### DO

- Mow up and down slopes greater than 5°, not across.
- Mow downhill only on slopes above 10°, never mow uphill. If a steep slope must be ascended, back up the hill, and drive forward down the hill, keeping the machine in gear.
- Remove obstacles such as rocks, tree limbs, etc. from the mowing area. Watch for holes, ruts or bumps, as uneven terrain could overturn the machine. Tall grass can hide obstacles.
- Use slow speed so that you will not have to stop while on the slope.
- Follow the manufacturer's recommendations for wheel weights or counterweights to improve stability.
- Use extra care with grass catchers or other attachments. These can change the stability of the machine.
- Keep all movement on slopes slow and gradual. Do not make sudden changes in speed or direction.
- Avoid starting or stopping on a slope. If tires lose traction, disengage the blades and proceed slowly straight down the slope.
- When operating machine on slopes, banks or near drop offs, always have ROPS (roll over protection) installed.

- When operating a machine with ROPS (roll over protection) always use seat belt.
- Be certain that the seat belt can be released quickly if the machine is driven or rolls into ponds or water.
- Check carefully for overhead clearances (i.e. branches, doorways, electrical wires) before driving under any objects and do not contact them.

#### DO NOT

- Do not operate machine on hillsides or slopes exceeding 15°.
- Avoid turning on slopes. If you must turn, turn slowly and gradually downhill, if possible.
- Do not mow near drop-offs, ditches, or embankments. The machine could suddenly turn over if a wheel goes over the edge of a cliff or ditch, or if an edge caves in.
- Do not mow on wet grass. Reduced traction could cause sliding.
- Do not try to stabilize the machine by putting your foot on the ground.
- Do not use a grass catcher on steep slopes. Heavy grass bags could cause loss of control or overturn the machine.

### Service

- Never store the machine or fuel container inside where there is an open flame, such as near a water heater or furnace.
- Keep nuts and bolts tight, especially the blade attachment bolts. Keep equipment in good condition.
- Never tamper with safety devices. Check safety systems for proper operation before each use.
- Use only genuine replacement parts to ensure that original standards are maintained.

- Check brake operation frequently. Adjust and service as required.
- Battery acid is poisonous and can cause burns. Avoid contact with skin, eyes and clothing. Protect your face, eyes and clothing when working with a battery.
- Battery gases can explode. Keep cigarettes, sparks and flames away from battery.
- Hydraulic fluid escaping under pressure can penetrate the skin and cause injury. Use cardboard or paper to find hydraulic leaks.
- Never modify ROPS (roll over protection) frames or structures because they are specifically designed, sized, located and tested for injury reduction. If a rollover occurs, a modified ROPS will not provide adequate protection.



# Slope Chart

Read all safety instructions on pages 5-7.

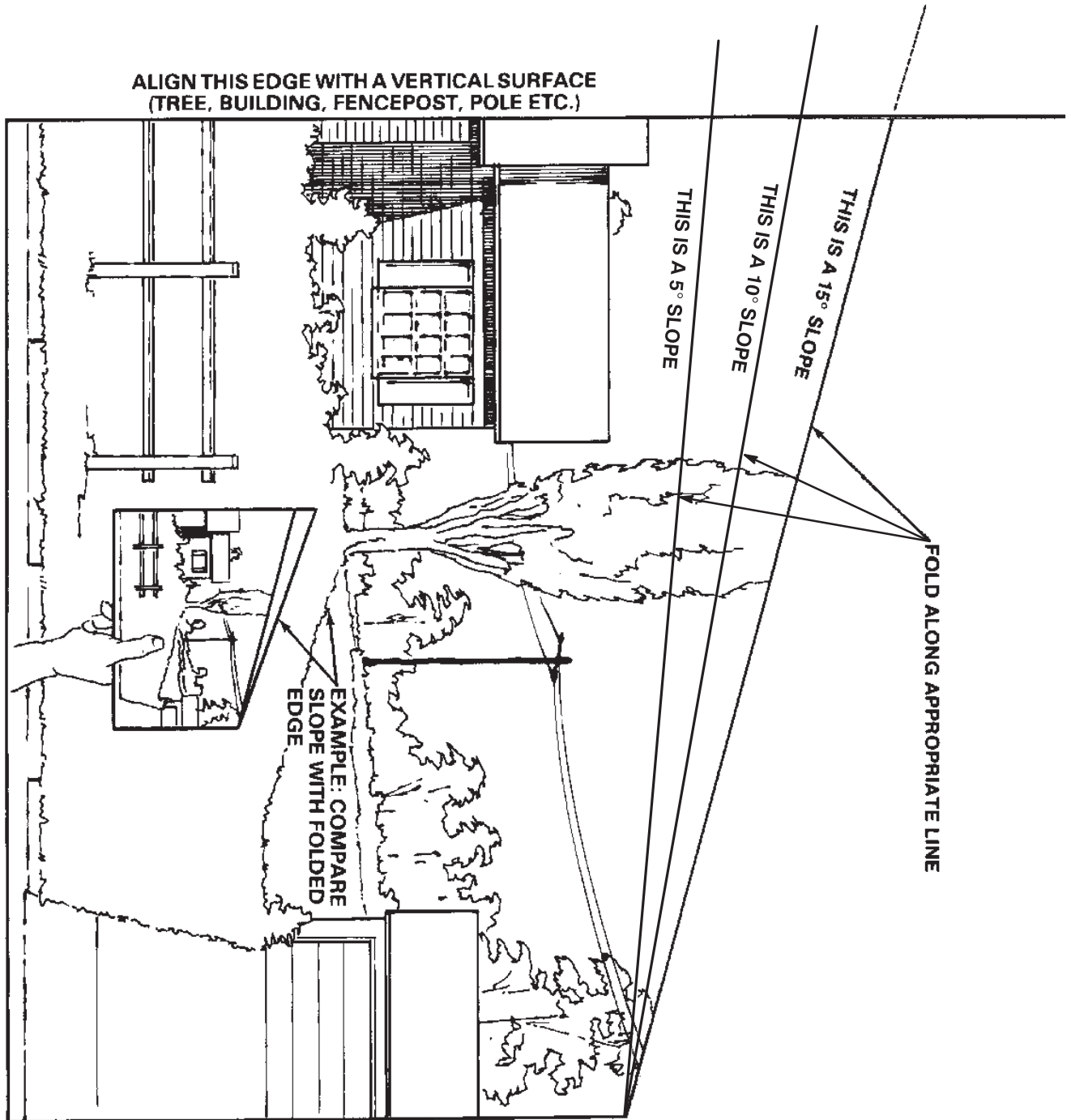



# Safety and Instruction Decals



Safety decals and instructions are easily visible to the operator and are located near any area of potential danger. Replace any decal that is damaged or lost.

**TOP OF CONSOLE UNDER SEAT  
(Part No. E513747)**

			<b>WARNING</b>	513747
BATTERY CONTAINS SULFURIC ACID, AVOID CONTACT AND ALWAYS SHIELD EYES, FACE, SKIN AND CLOTHING FROM BATTERY. CIGARETTES, FLAMES OR SPARKS COULD CAUSE BATTERY TO EXPLODE. DO NOT CHARGE			OR USE BOOSTER CABLES OR ADJUST POST CONNECTIONS WITHOUT PROPER TRAINING. IN EVENT OF AN ACCIDENT FLUSH WITH WATER AND CALL A PHYSICIAN IMMEDIATELY. KEEP OUT OF REACH OF CHILDREN.	

**ON RIGHT SIDE OF HEIGHT OF CUT PLATE  
(Part No. 99-4688)**

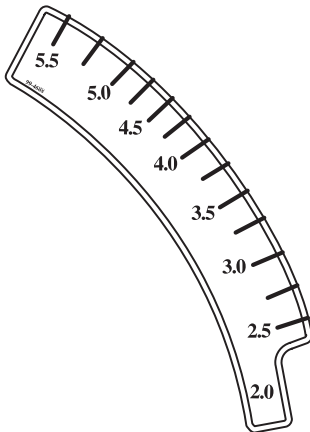

**ON LEFT SIDE OF HEIGHT-OF-CUT PLATE  
(Part No. 99-4687)**

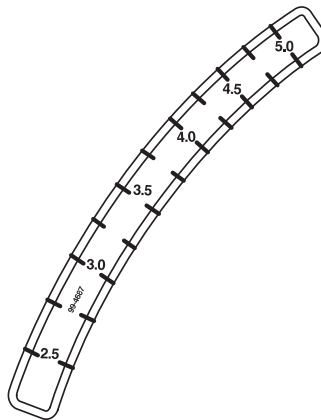

**ON TOP OF CONSOLE LEFT AND RIGHT SIDES  
(Part No. E633354)**



**TOP OF CONSOLE UNDER SEAT  
(Part No. E643372)**

	<b>CAUTION</b>	
Mercury in tilt switch is poisonous and can cause severe illness.		
<ul style="list-style-type: none"> <li>• Never attempt to open or repair switch.</li> <li>• Avoid contact with mercury.</li> <li>• See operator's manual for disposal guide.</li> </ul>		
Hg		E643372

**ON TILT SWITCH  
(Part No. E643401)**

MERCURY SWITCH	633782
SEE OPERATOR'S MANUAL FOR DISPOSAL INSTRUCTIONS	
	E643401

**BELOW CENTER OF CONSOLE  
(Part No. E633346)**

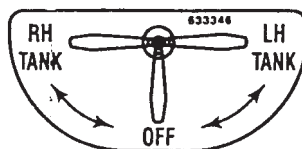

**UNDER FOOTREST  
(Part No. E633766)**

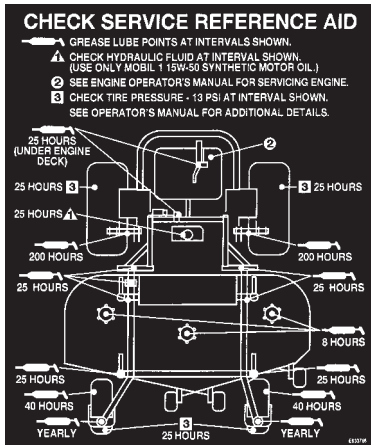

**ON TOP OF RIGHT  
ENGINE BAFLE  
(Part No. E643339)**

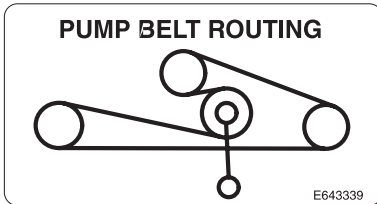

**ON RUBBER FLAP BEHIND SEAT  
(Part No. E513748)**



**ON RUBBER FLAP  
BEHIND SEAT  
(Part No. E643252)**



**ON CONSOLE AND RUBBER  
FLAP BEHIND SEAT  
(Part No. E633462)**

**IMPORTANT:**  
BEFORE STARTING ENGINE  
CLEAN GRASS FROM PUMP  
DRIVE BELT COMPARTMENT.  
CHECK MORE OFTEN IN DRY  
CONDITIONS

**ON CONTROL PANEL  
(Part No. 99-4611)**

**DISENGAGE**

**ENGAGE**

**CHOKER**

**THROTTLE**

**BRAKE**

**DANGER TO AVOID SERIOUS INJURY OR DEATH:**

- READ & UNDERSTAND THE OPERATOR'S MANUAL.
- USE SAFELY; MACHINE IS NOT A TOY.
- NEVER USE WHEN UNDER THE INFLUENCE OF ALCOHOL OR DRUGS.
- KNOW LOCATION AND FUNCTION OF CONTROLS.
- KEEP SAFETY SHIELDS IN PLACE AND WORKING.
- CHECK PERFORMANCE OF ALL INTERLOCK SWITCHES DAILY. DO NOT DEFEAT INTERLOCK SYSTEM. IT IS FOR YOUR PROTECTION.
- STOP ENGINE, SET PARKING BRAKE AND REMOVE KEY BEFORE LEAVING MACHINE.

FOR REPLACEMENT MANUAL, SEND MODEL & SERIAL NUMBER TO: THE TORO CO., 8111 LYNDALE AVE. S., BLOOMINGTON, MN 55420.

**DANGER**

- NEVER CARRY CHILDREN OR OTHER PASSENGERS.
- LOOK DOWN AND BEHIND BEFORE AND WHILE BACKING UP.
- NEVER MOW WHEN CHILDREN, PEOPLE OR PETS ARE IN MOWING AREA.
- GO UP AND DOWN SLOPES, NOT ACROSS.
- IF MACHINE STOPS GOING UP HILL, STOP BLADE AND BACK SLOWLY DOWN.
- AVOID SHARP OR SUDDEN TURNS & SLIPPERY OR STEEP AREAS.
- AVOID BLADE UNLESS BLADE & ENGINE ARE STOPPED.
- REMOVE OBJECTS THAT COULD BE THROWN BY THE BLADE.
- THROWN OBJECTS OR BLADE CONTACT CAN CAUSE SERIOUS INJURY OR DEATH.

**IMPORTANT: BEFORE STARTING ENGINE CLEAN GRASS FROM PUMP DRIVE BELT COMPARTMENT, CHECK MORE OFTEN IN DRY CONDITIONS.**

**ON LEFT SIDE GAS TANK  
(Part No. 99-4632)**

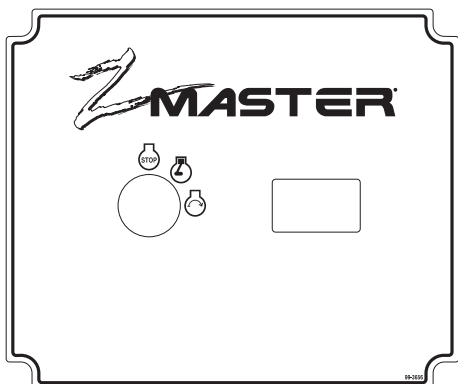

**ON TOP OF HYDRAULIC  
RESERVOIR  
(Part No. E523552)**



**ON HYDRAULIC RESERVOIR  
MOUNTING BRACKET  
(Part No. E513929)**

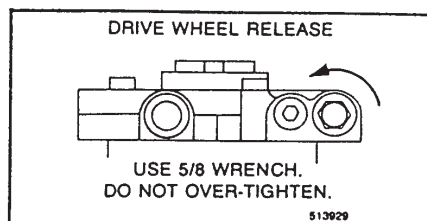

**ON FRONT CONSOLE  
(Part No. 98-4387)**



**NEXT TO ANTI-SCALP  
ROLLER (Part No. 98-3798)**

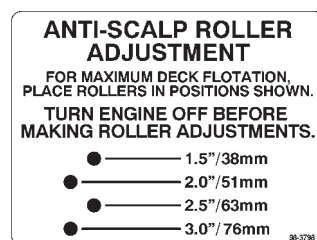

**ON DECK SUPPORT FRAME  
(Part No. E633818)**

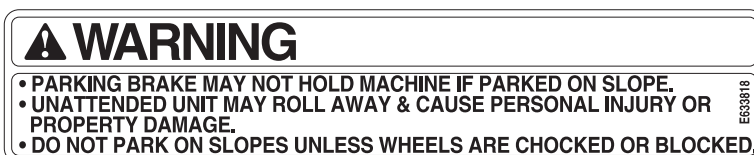

100-4260

**ON RIGHT SIDE OF MOWER  
(Part No. 66-1340)**



**ON LEFT SIDE OF MOWER  
(Part No. 43-8480)**



**(2) ON BELT COVERS  
(Part No. 67-5360)**



**ON TOP CENTER OF MOWER  
(Part No. 99-4686)**

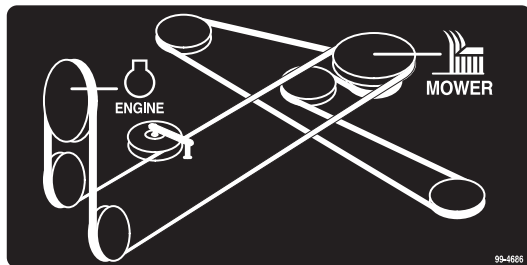

**UNDER DEFLECTOR  
(Part No. 66-6380)**



**ON DEFLECTOR  
(Part No. 54-9220)**



**UNDER FOOTREST AND (3)  
UNDER PULLEY COVERS  
(Part No. 98-5954)**



**ON LEFT FRONT OF MOWER  
(Part No. 93-7818)**

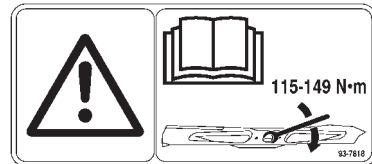

# Gasoline and Oil

## Recommended Gasoline

Use UNLEADED Regular Gasoline suitable for automotive use (85 pump octane minimum). Leaded regular gasoline may be used if unleaded regular is not available.

**IMPORTANT:** Never use methanol, gasoline containing methanol, or gasohol containing more than 10% ethanol because the fuel system could be damaged. Do not mix oil with gasoline.

### DANGER

#### POTENTIAL HAZARD

- In certain conditions gasoline is extremely flammable and highly explosive.

#### WHAT CAN HAPPEN

- A fire or explosion from gasoline can burn you, others, and cause property damage.

#### HOW TO AVOID THE HAZARD

- Fill the fuel tank outdoors, in an open area, when the engine is cold. Wipe up any gasoline that spills.
- Do not fill the fuel tank completely full. Add gasoline to the fuel tank until the level is 1/4" to 1/2" (6 mm to 13 mm) below the bottom of the filler neck. This empty space in the tank allows gasoline to expand.
- Never smoke when handling gasoline, and stay away from an open flame or where gasoline fumes may be ignited by a spark.
- Store gasoline in an approved container and keep it out of the reach of children. Never buy more than a 30-day supply of gasoline.

### DANGER

#### POTENTIAL HAZARD

- In certain conditions gasoline is extremely flammable and highly explosive.

#### WHAT CAN HAPPEN

- A fire or explosion from gasoline can burn you, others, and cause property damage.

#### HOW TO AVOID THE HAZARD

- Always place gasoline containers on the ground away from your vehicle before filling.
- Do not fill gasoline containers inside a vehicle or on a truck or trailer bed because interior carpets or plastic truck bed liners may insulate the container and slow the loss of any static charge.
- When practical, remove gas-powered equipment from the truck or trailer and refuel the equipment with its wheels on the ground.
- If this is not possible, then refuel such equipment on a truck or trailer from a portable container, rather than from a gasoline dispenser nozzle.
- If a gasoline dispenser nozzle must be used, keep the nozzle in contact with the rim of the fuel tank or container opening at all times until fueling is complete.

 **WARNING**

**POTENTIAL HAZARD**

- Gasoline is harmful or fatal if swallowed. Long-term exposure to vapors has caused cancer to laboratory animals.

**WHAT CAN HAPPEN**

- Failure to use caution may result in serious injury or illness

**HOW TO AVOID THE HAZARD**

- Avoid prolonged breathing of vapors.
- Keep face away from nozzle and gas tank or conditioner opening.
- Keep gas away from eyes and skin.

## Using Stabilizer/Conditioner

Use a fuel stabilizer/conditioner in the machine to provide the following benefits:

- Keeps gasoline fresh during storage of 90 days or less. For longer storage it is recommended that the fuel tank be drained.
- Cleans the engine while it runs
- Eliminates gum-like varnish buildup in the fuel system, which causes hard starting

**IMPORTANT: Do not use fuel additives containing methanol or ethanol.**

Add the correct amount of gas stabilizer/conditioner to the gas.

**Note:** A fuel stabilizer/conditioner is most effective when mixed with fresh gasoline. To minimize the chance of varnish deposits in the fuel system, use fuel stabilizer at all times.

## Filling the Fuel Tank

1. Shut the engine off and set the parking brake.
2. Clean around each fuel tank cap and remove the cap. Add unleaded regular gasoline to both fuel tanks, until the level is 1/4 to 1/2 inch (6 mm to 13 mm) below the bottom of the filler neck. This space in the tank allows gasoline to expand. Do not fill the fuel tanks completely full.
3. Install fuel tank caps securely. Wipe up any gasoline that may have spilled.

## Check Engine Oil Level

Before you start the engine and use the machine, check the oil level in the engine crankcase; refer to Checking Oil Level, page 41.

# Assembly

## Loose Parts

**Note:** Use the chart below to verify all parts have been shipped.

DESCRIPTION	QTY.	USE
Rear Wheels	2	Install wheels to traction unit
Retaining rod	1	Install seat rod
Bolt 5/16–18 x 1" (26 mm)	1	
Locknut 5/16"	1	
Control lever–right	1	Install motion control levers
Control lever–left	1	
Bolt 3/8–1 x 1" (26 mm)	4	
Spring washer 3/8"	4	
Key	2	Read before operating machine
Operator's Manual	1	
Engine Operator's Manual	1	
Parts Catalog	1	
Registration card	1	
		Fill out and return to Toro

## Install Drive Wheels

1. Uncrate mower.
2. Remove wheel nuts from rear wheel hubs.
3. Align holes. Mount drive wheels with the valve stem to the outside of the traction unit.
4. Secure using wheel nuts provided. Torque to 95ft-lbs (128 N•M).

**IMPORTANT: Make sure that wheel nuts are torqued to 95ft-lbs (128 N•M).**

## Tire Pressure

Check the air pressure in the front and rear tires (Fig. 1).

Pressure: 13 psi (90 kPa)

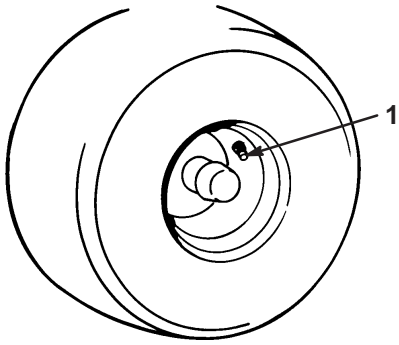

m-1872

**Figure 1**

1. Valve stem

## Install Seat Retaining Rod

1. Tilt seat up. Remove 5/16" (8mm) locknut from bolt attaching seat retaining rod to seat frame (Fig. 2).
2. Remove retaining rod from seat and insert the "L" shaped end of the rod into the hole directly above the left-side hydraulic pump mounting hardware (Fig. 2).
3. Place the seat retaining rod to the outside of the mounting tab of the seat frame and secure with 5/16-18 x 1" (26 mm) bolt and 5/16" (8mm) locknut (Fig. 2).
4. Tighten until snug, then loosen so the rod pivots freely.

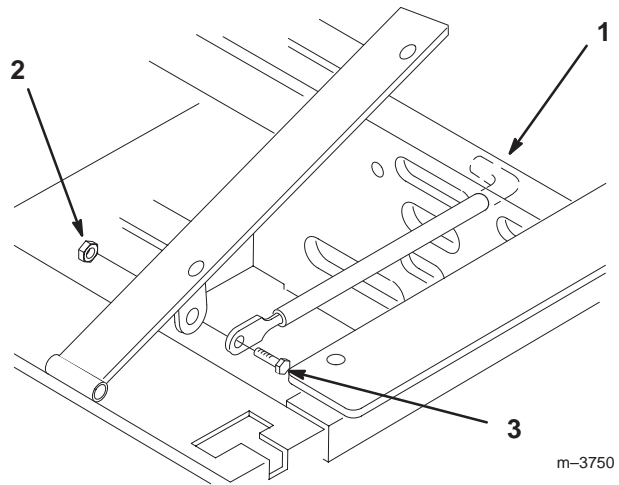

m-3750

**Figure 2**

1. L end of retaining rod
2. Locknut 5/16"
3. Bolt 5/16-18 x 1" (26 mm)

## Install Motion Control Levers

1. Remove the (4) 3/8–16 x 1" (26 mm) bolts and (4) 3/8" spring washers which attach the motion control levers to the control arm shafts for shipping (Fig. 3).
2. Place the levers (with the mounting plate toward the rear) on the outside of the control arm shaft and secure with (4) 3/8–16 x 1" (26 mm) bolts and (4) 3/8" spring washers (Fig. 3).
3. Position the levers so the bolts are in the center of the slots on the lever mounting plate and tighten until snug.
4. Align the front/rear position of the levers, with each other, in the neutral position. Loosen hardware and adjust by sliding/tilting the lever(s) forward or backward until properly aligned (Fig. 3).

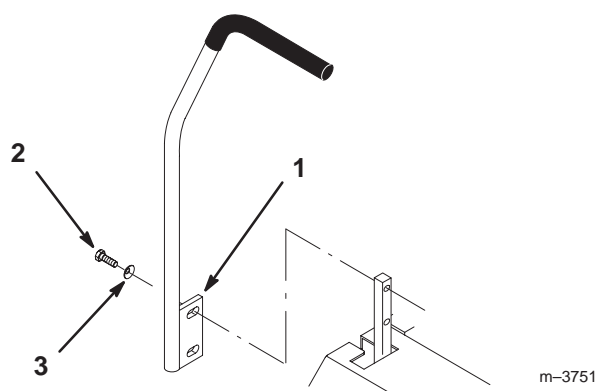

Figure 3

- |                             |                       |
|-----------------------------|-----------------------|
| 1. Mounting plate           | 3. Spring washer 3/8" |
| 2. Bolt 3/8–18 x 1" (26 mm) |                       |

5. If the ends of the levers hit against each other, while in the drive position (Fig 4) (levers rotated in as far as possible) make adjustments by moving the levers outward to the neutral lock position and carefully bend them outward. Move them back to the drive position and check for clearance. Repeat if necessary.

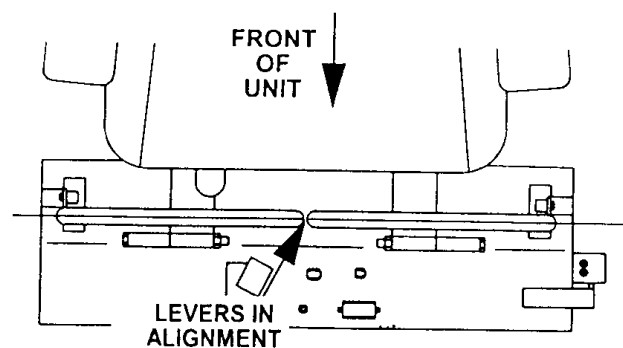

Figure 4

## Check Side Discharge Chute

Remove plastic tie holding side discharge chute up and lower into place.

## Check the Leveling of Mower Deck

Check the level of the deck before the machine is first put in use.

Refer to Mower Leveling and Compression Spring Adjustment in the Maintenance section on page 55.

## Activate the Battery

Bulk electrolyte with 1.260 specific gravity must be purchased from a local battery supply outlet.

1. Tilt seat up and remove battery.
2. First disconnect the negative battery cable and ground wire from the negative (-) battery terminal.
3. Slide the red terminal boot off the positive (red) battery terminal. Then remove positive (red) battery cable.
4. Remove battery hold down clamp.

**IMPORTANT:** Be careful not to damage the long vent tube when removing the battery box.

7. Remove filler caps from the battery. Slowly pour electrolyte into each cell until the electrolyte level is up to the lower part of the tube (Fig. 5).

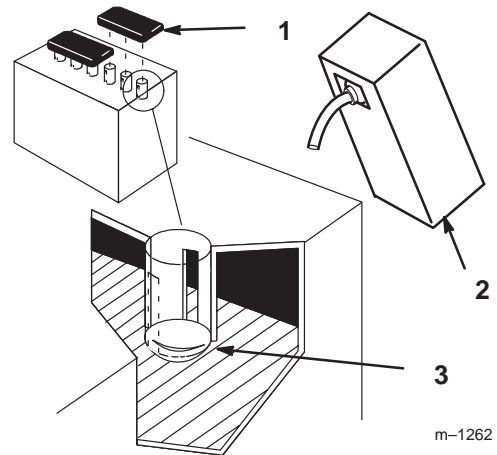

Figure 5

1. Filler caps
2. Electrolyte
3. Lower part of the tube

**DANGER**

**POTENTIAL HAZARD**

- Battery electrolyte contains sulfuric acid which is a deadly poison and it causes severe burns.

**WHAT CAN HAPPEN**

- If you carelessly drink electrolyte you could die or if it gets onto your skin you will be burned.

**HOW TO AVOID THE HAZARD**

- Do not drink electrolyte and avoid contact with skin, eyes or clothing. Wear safety glasses to shield your eyes and rubber gloves to protect your hands.
- Fill the battery where clean water is always available for flushing the skin.
- Follow all instructions and comply with all safety messages on the electrolyte container.

5. Remove battery from machine.
6. Place battery on a level surface.

8. Leave the covers off and connect a 3 to 4 amp battery charger to the battery posts (Fig. 6). Charge the battery at a rate of 4 amperes or less for 4 hours (12 volts).

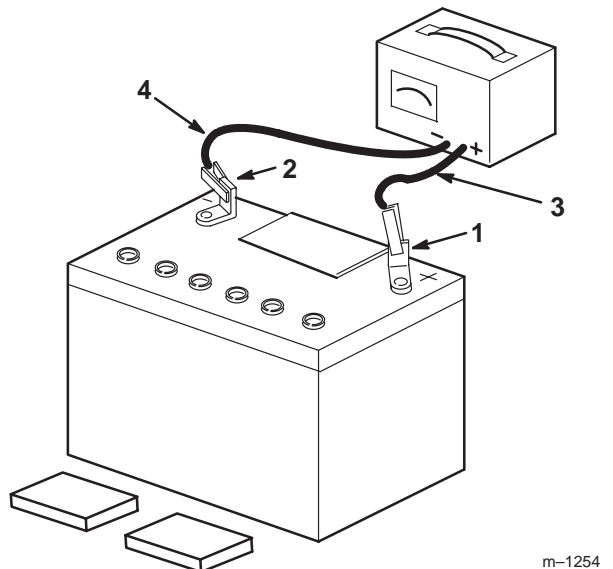

Figure 6

1. Positive post
2. Negative post
3. Charger red (+) wire
4. Charger black (-) wire

**! WARNING**

**POTENTIAL HAZARD**

- Charging battery produces gasses.

**WHAT CAN HAPPEN**

- Battery gasses can explode causing serious injury.

**HOW TO AVOID THE HAZARD**

- Keep cigarettes, sparks and flames away from battery.
- Make sure the ignition switch is in the "OFF" position.
- Ventilate when charging or using battery in an enclosed space.
- Make sure venting path of battery is always open when battery is filled with acid.

9. When the battery is fully charged, disconnect the charger from the electrical outlet then from the negative and positive battery posts (Fig. 6).
10. Slowly pour electrolyte into each cell until the level is once again up to the "UPPER" line on the battery case (Fig. 5) and install covers.
11. Wash off any spilled acid with water. Dry off the battery.

**Install Battery**

1. Position battery in tray with terminal posts toward the engine (Fig. 7).
2. First, install the positive (red) battery cable to positive (+) battery terminal.
3. Then install negative battery cable and ground wire to the negative (-) battery terminal.
4. Secure cables with (2) 1/4 x 3/4" (19 mm) bolts 1/4" washers and 1/4" locknuts (Fig. 7).
5. Slide the red terminal boot onto the positive (red) battery post.
6. Secure battery with J-bolts, hold down clamp and (2) 1/4" washers and (2) 1/4" wing nuts (Fig. 7).
7. Position drain tube away from belts and other parts to prevent corrosion.

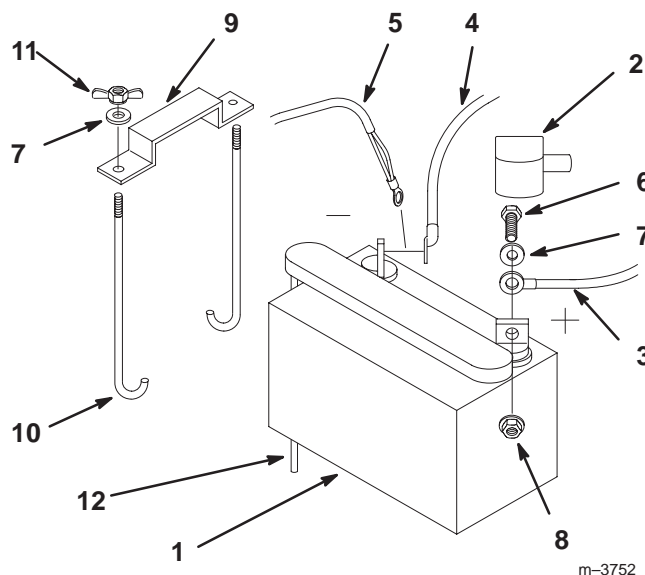

**Figure 7**

- |                               |                   |
|-------------------------------|-------------------|
| 1. Battery                    | 7. Washer 1/4"    |
| 2. Terminal boot              | 8. Locknut 1/4"   |
| 3. Positive battery cable     | 9. Battery clamp  |
| 4. Negative battery cable     | 10. J-bolts       |
| 5. Ground wire                | 11. Wing nut 1/4" |
| 6. Bolt 1/4-20 x 3/4" (19 mm) | 12. Drain Tube    |

## Hydraulic System

### Checking the Hydraulic Fluid

Check the hydraulic fluid level before engine is first started.

Fluid Type: Mobil 1 15W-50 synthetic motor oil.

**IMPORTANT: Use only oil specified. Other fluids could cause system damage.**

Hydraulic System Oil Capacity: 2.1 qt. (2.0 l)

1. Position machine on a level surface and set the parking brake.
2. Clean area around filler neck of hydraulic tank (Fig. 8).
3. Remove cap from filler neck. Look inside to check if there is fluid in the reservoir. (Fig. 8).
4. If there is no fluid, add fluid to reservoir approximately a 1/4" (6mm) below the top of baffle.
5. Run the machine 15 minutes to allow any air to purge out of the system and warm fluid.
6. Recheck level while fluid is warm. Add fluid to raise level to top of the baffle, if required.  
  
**Note:** Fluid level should be to the top of the baffle when fluid is warm (Fig. 8).
7. Install cap on filler neck.

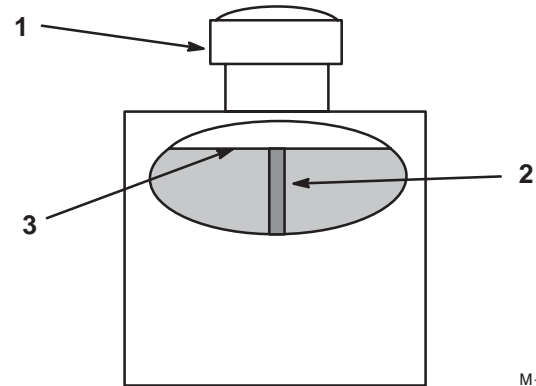

M-4280

Figure 8

1. Cap
2. Baffle
3. Fluid level-Full

### WARNING

#### POTENTIAL HAZARD

- Hydraulic fluid escaping under pressure can penetrate skin and cause injury.

#### WHAT CAN HAPPEN

- Fluid accidentally injected into the skin must be surgically removed within a few hours by a doctor familiar with this form of injury or gangrene may result.

#### HOW TO AVOID THE HAZARD

- Make sure all hydraulic fluid hoses and lines are in good condition and all hydraulic connections and fittings are tight before applying pressure to hydraulic system.
- Keep body and hands away from pin hole leaks or nozzles that eject high pressure hydraulic fluid.
- Use cardboard or paper to find hydraulic leaks.
- Safely relieve all pressure in the hydraulic system before performing any work on the hydraulic system.

## Greasing the Bearings

### Greasing the Bearings

**Make sure cutting unit spindles are full of grease before engine is first started.**

Grease with No. 2 general purpose lithium base or molybdenum base grease.

1. Grease the fittings on the three spindle bearings. Grease until it comes out lower seals (Fig. 9).

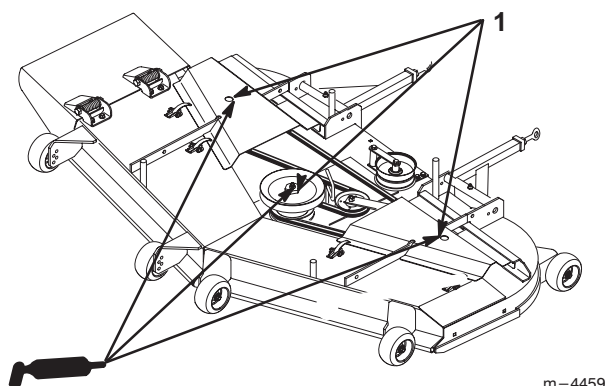

m-4459

**Figure 9**

1. Spindles

## Check Side Discharge Chute

Remove plastic tie holding side discharge chute up and lower into place.

## Check the Leveling of Mower Deck

Check the level of the deck before the machine is first put in use.

Refer to Mower Leveling and Compression Spring Adjustment in the Maintenance section on page 55.

## Check Engine Oil Level

Before you start the engine and use the machine, check the oil level in the engine crankcase; refer to Checking Oil Level, page 41.

# Operation

## Think Safety First

Please carefully read all the safety instructions on pages 3–8. Knowing this information could help you, your family, pets or bystanders avoid injury.

## Controls

Become familiar with all the controls (Fig. 1) before you start the engine and operate the machine.

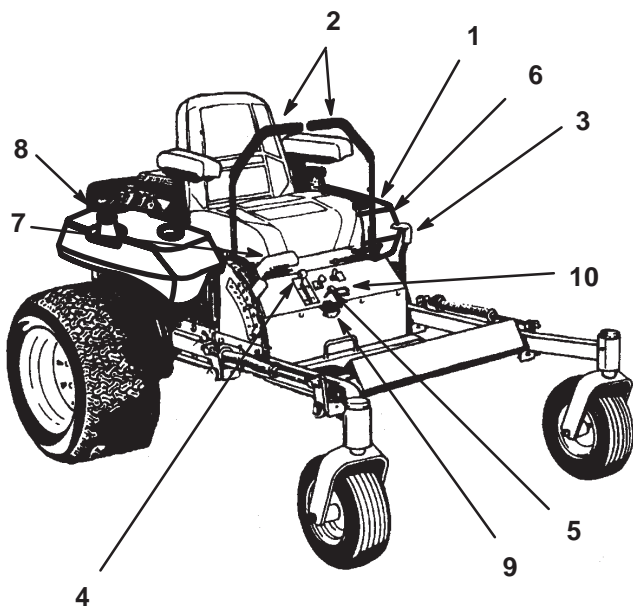

Figure 1

- |                         |                         |
|-------------------------|-------------------------|
| 1. Ignition switch      | 6. Power take off (PTO) |
| 2. Motion control lever | 7. Height-of-Cut lever  |
| 3. Parking brake lever  | 8. Fuel cap             |
| 4. Throttle             | 9. Fuel shut off lever  |
| 5. Choke                | 10. Hour meter          |

## Parking Brake

Always set the parking brake when you stop the machine or leave it unattended.

### Setting the Parking Brake

1. Move the motion control levers (Fig. 1) out to the neutral lock position.
2. Pull back and up on the parking brake lever to set the parking brake (Fig. 2). The parking brake lever should stay firmly in the “ENGAGED” position.

### WARNING

#### POTENTIAL HAZARD

- Parking break may not hold machine if parked on slope.

#### WHAT CAN HAPPEN

- Unattended unit may roll away and cause personal injury or property damage.

#### HOW TO AVOID THE HAZARD

- Do not park on slopes unless wheels are chocked or blocked.

## Releasing the Parking Brake

1. Push forward and down on the parking brake lever to release the parking brake (Fig. 2). The parking brake is “DISENGAGED” and the lever rests against the brake stop.

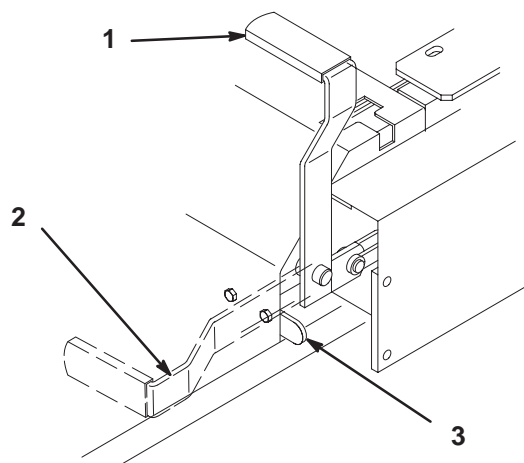

Figure 2

- |                      |               |
|----------------------|---------------|
| 1. Parking brake-ON  | 3. Brake Stop |
| 2. Parking brake-OFF |               |

## Starting and Stopping the Engine

### Starting

1. Sit on the seat and move the motion controls to neutral locked position.
2. Set the parking brake; refer to Setting the Parking Brake, page 24.
3. Move the PTO (power take off) switch to “OFF” (Fig. 3).
4. Move the choke control to “ON” position before starting a cold engine.

**Note:** A warm or hot engine may not require choking. After engine starts, move choke control to “RUN” position.

5. Move the throttle control to the “FAST” position before starting a cold engine.

6. Turn ignition key “START” to energize starter. When engine starts, release key.

**IMPORTANT: Do not engage starter for more than 10 seconds at a time. If engine fails to start allow 30 second cool-down period between attempts. Failure to follow these instructions can burn out the starter motor.**

7. After the engine starts, move the choke to “OFF” (Fig. 4). If the engine stalls or hesitates, move the choke back to “ON” for a few seconds. Then move the throttle lever to desired setting. Repeat this as required.

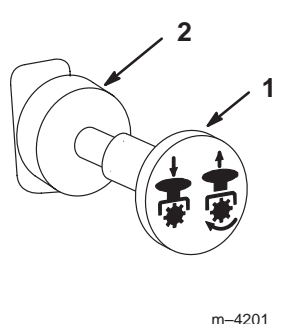

m-4201

Figure 3

1. PTO-On
2. PTO-Off

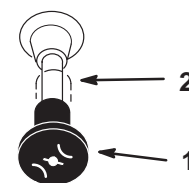

m-2719

Figure 4

1. Choke-On
2. Choke-Off

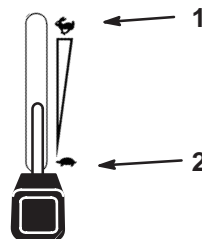

m-2720

Figure 5

1. Throttle-Fast
2. Throttle-Slow

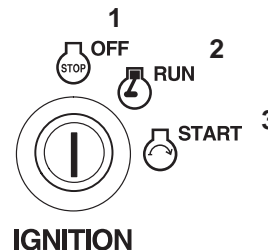

M-4268

Figure 6

1. Off
2. Run
3. Start

## Stopping

1. Move the throttle lever to “SLOW” (Fig. 5).
2. Turn the ignition key to “OFF” (Fig. 6).

**Note:** If the engine has been working hard or is hot, let it idle for a minute before turning the ignition key “OFF.” This helps cool the engine before it is stopped. In an emergency, the engine may be stopped by turning the ignition key to “OFF.”

3. Pull wire off spark plug(s) to prevent possibility of someone accidentally starting the machine before transporting or storing machine.
4. Close fuel shut off valve, on front panel before transporting or storing machine.

**IMPORTANT:** Make sure fuel shut off valve is closed before transporting or storing machine, as fuel leakage may occur. Set parking brake before transporting.

## Operating the Power Take Off (PTO)

The power take off (PTO) switch engages and disengages power to the electric clutch.

### Engaging the PTO

1. Release pressure on the traction control levers and place in neutral, refer to traction unit Operator’s Manual.
2. Release the parking brake, refer to traction unit Operator’s Manual.
3. Pull out on the power take off (PTO) switch to engage (Fig. 7).

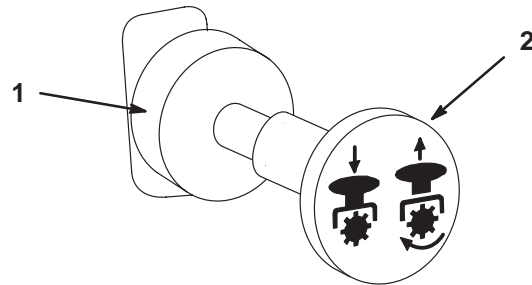

m-4201

**Figure 7**

1. PTO – Off
2. PTO – On

---

### Disengaging the PTO

1. To disengage push the PTO switch to the “OFF” position (Fig. 7).

## The Safety Interlock System

### Understanding the Safety Interlock System

The safety interlock system is designed to prevent the engine from starting unless:

- You are sitting on the seat
- The parking brake is “ENGAGED”
- The power take off (PTO) is disengaged “OFF”
- The motion control levers are in neutral locked position

The safety interlock system also is designed to stop the engine when the traction controls are moved from the locked position with the parking brake “ENGAGED” or if you rise from the seat when the PTO is “ON” engaged.

### Testing the Safety Interlock System

Test the safety interlock system before you use the machine each time. If the safety system does not operate as described below, have an Authorized Service Dealer repair the safety system immediately.

1. Sitting on the seat, “ENGAGE” parking brake and move PTO “ON”. Try starting the engine; the engine should not crank.
2. Sitting on the seat, “ENGAGE” parking brake and move PTO “OFF”. Move either motion control lever (out of neutral locked position). Try starting the engine; the engine should not crank. Repeat for other control lever.
3. Sitting on the seat, “ENGAGE” parking brake, move PTO switch “OFF” and move the motion control levers to neutral lock position. Now start the engine. While the engine is running, release the parking brake, engage the PTO and rise slightly from the seat; the engine should stop.
4. Sitting on the seat, “ENGAGE” parking brake, move PTO switch “OFF” and move the motion control levers to neutral lock position. Now start the engine. While the engine is running, center either motion control and move (forward or reverse); the engine should stop.
5. Sitting on the seat, “DISENGAGE” parking brake, move PTO switch “OFF” and move the motion control levers to neutral lock position. Try starting the engine; the engine should not crank.

## Driving Forward or Backward

The throttle control regulates the engine speed as measured in rpm (revolutions per minute). Place the throttle control in the “FAST” position for best performance. Always operate in the full throttle position when mowing.

### CAUTION

#### POTENTIAL HAZARD

- Machine can spin very rapidly by positioning one lever too far ahead of the other.

#### WHAT CAN HAPPEN

- Operator may lose control of the machine and cause injury or damage to machine.

#### HOW TO AVOID THE HAZARD

- Use caution when making turns.
- Slow the machine down before making sharp turns.

### Forward

1. Release the parking brake; refer to Setting the Parking Brake, page 24.
2. Move levers to the center, un-locked position.
3. To go forward, slowly push the motion control levers forward (Fig. 8).

**Note:** Engine will kill if traction control levers are moved with parking brake engaged.

To go straight, apply equal pressure to both motion control levers (Fig. 8).

To turn, move the motion control lever toward neutral in the direction you want to turn (Fig. 8).

The farther you move the traction control levers in either direction, the faster the machine will move in that direction.

To stop pull the motion control levers to neutral.

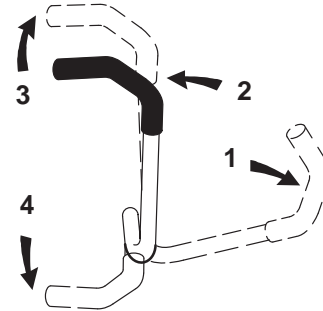

m-2715

Figure 8

- |   |             |
|---|-------------|
| 1. Motion control lever-neutral lock position | 3. Forward  |
| 2. Center un-lock position                    | 4. Backward |

### Backward

1. Move levers to the center, un-locked position.
2. To go backward, slowly pull the motion control levers rearward (Fig. 8).

To go straight, apply equal pressure to both motion control levers (Fig. 8).

To turn, release pressure on the motion control lever toward the direction you want to turn (Fig. 8).

To stop push the motion control levers to neutral.

## Stopping the Machine

To stop the machine, move the traction control levers to neutral and move to locked position, disengage the power take off (PTO), and turn the ignition key to “OFF”. Also set the parking brake when you leave the machine; refer to Setting the Parking Brake, page 24. Remember to remove the key from the ignition switch.

## CAUTION

### POTENTIAL HAZARD

- Someone could move or attempt to operate the tractor while it is unattended.

### WHAT CAN HAPPEN

- Children or bystanders may be injured if they use the tractor.

### HOW TO AVOID THE HAZARD

- Always remove the ignition key and set the parking brake when leaving the machine, even if just for a few minutes.

## Instruments

### Hour Meter

The hour meter records the number of hours the engine has operated. It operates when the engine is running. Use these times for scheduling regular maintenance.

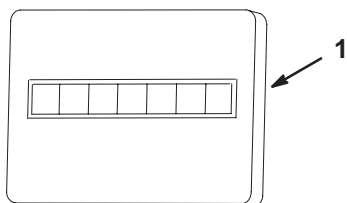

m-3077

**Figure 9**

1. Hour meter

## Fuel Tanks

The unit has two fuel tanks, located on the left and right sides. Each tank connects to the fuel shut off valve in the control panel. From there a common fuel line leads to the engine (Fig. 10).

To use the right side fuel tank rotate the fuel shut off valve 1/4 turn to the right from the off location. This uses fuel from the right side tank only. When the right hand fuel tank is empty, move the fuel shut off valve 1/4 turn to the left from the off position.

Close fuel shut off valve, on front panel before transporting or storing machine.

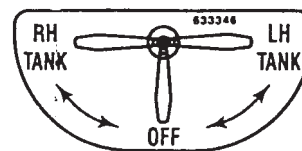

**Figure 10**

1. Shut off valve

## Adjusting Height-of-Cut

The height-of-cut is adjusted from 2" to 5-1/2" (51 to 140 mm) in 1/4" (6 mm) increments by relocating clevis pin in different hole locations.

1. Raise the height-of-cut lever to the transport position (also the 5-1/2" (140 mm) cutting height position) (Fig. 11).
2. To adjust, remove hairpin cotter and clevis pin from height-of-cut bracket (Fig. 11).
3. Select hole in height-of-cut bracket corresponding to the height-of-cut desired. Lift handle to transport position, insert clevis pin (Fig. 11).
4. Secure clevis pin with hairpin cotter (Fig. 11).
5. Move lever to selected height.

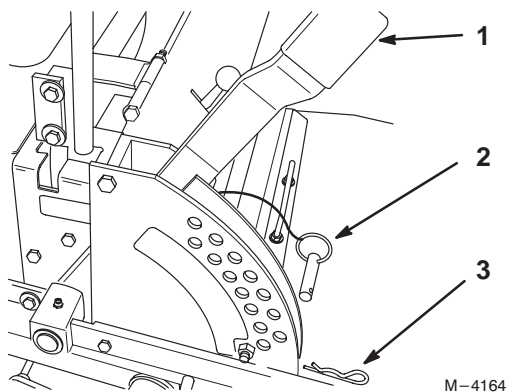

Figure 11

1. Height of cut lever
2. Clevis Pin
3. Hairpin Cotter

## Adjusting Anti-Scalp Rollers

Whenever you change the height-of-cut it is recommended to adjust the height of the anti-scalp rollers.

1. Disengage the power take off (PTO) and turn the ignition key to "OFF" to stop the engine. Move controllers to neutral locked position and apply parking brake. Remove the key.
2. After adjusting height-of-cut remove flange nut and spring disk while holding stud with wrench (Fig. 12).

**Note:** Do not remove the wheel nut and washer (Fig. 12).

3. Select hole so gage wheel is positioned to the nearest corresponding height-of-cut desired (Fig. 12).
4. Reinstall the flange nut and spring disk. Torque to 40–45 ft–lbs. (54.2–61.0 N•m) (Fig. 12).
5. Repeat adjustment on other gage wheels.

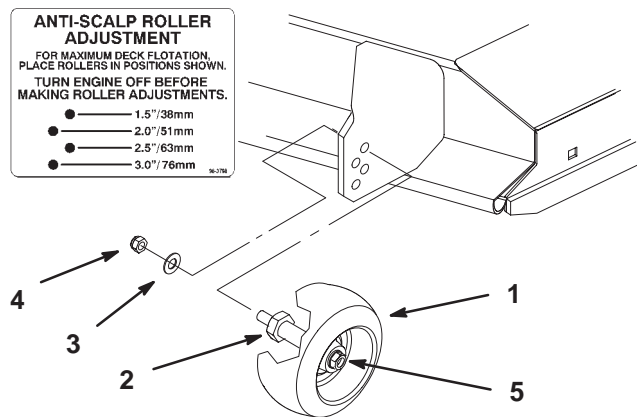

Figure 12

1. Gage Wheel
2. Stud
3. Spring Disk
4. Flange Nut
5. Wheel nut and washer. Do Not Remove.

## Positioning the Seat

The seat can move forward and backward. Position the seat where you have the best control of the machine and are most comfortable.

1. To adjust, move the lever sideways to unlock seat (Fig. 13).
2. Slide the seat to the desired position and release lever to lock in position.

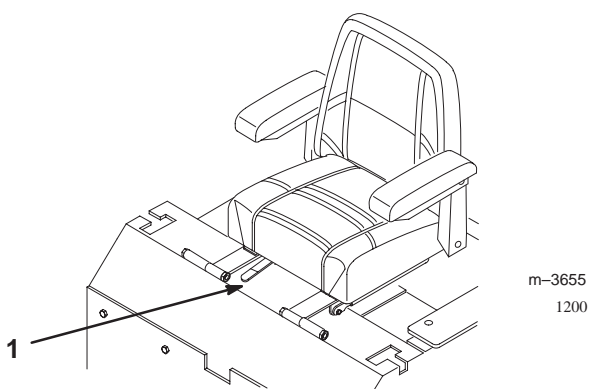

**Figure 13**

1. Adjustment knob

## Pushing the Machine by Hand

**IMPORTANT: Always push the machine by hand. Never tow the machine because hydraulic damage may occur.**

### To Push the Machine

1. Disengage the power take off (PTO) and turn the ignition key to “OFF” to stop the engine. Move controllers to neutral locked position and apply parking brake.
2. Rotate the by-pass valves counterclockwise 1 turn to push. This allows hydraulic fluid to by-pass the pump enabling the wheels to turn (Fig. 14).

**IMPORTANT: Rotate by-pass valves a maximum of 2 turns so the valves do not come out of the body causing fluid to run out.**

3. Disengage parking brake before pushing.

### To Operate the Machine

1. Rotate the by-pass valves clockwise 1 turn to operate machine (Fig. 14).

**Note:** The machine will not drive unless by-pass valves are turned in.

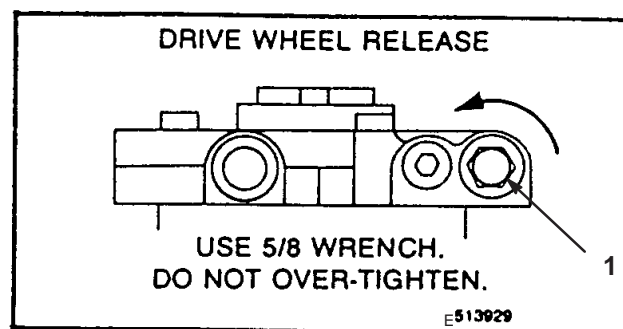

**Figure 14**

1. By-pass valve

## Transporting Machines

Use a heavy-duty trailer or truck to transport the machine. Ensure that the trailer or truck has all necessary lighting and marking as required by law. Please carefully read all the safety instructions on pages 3–13. Knowing this information could help you, your family, pets or bystanders avoid injury.

To transport the machine:

- Lock brake and block wheels.
- Securely fasten the machine to the trailer or truck with straps, chains, cable, or ropes.
- Secure a trailer with a safety chains to towing vehicle.

### CAUTION

#### POTENTIAL HAZARD

- **This unit does not have proper turn signals, lights, reflective markings, or a slow moving vehicle emblem. These items are required to drive on a public street or roadway.**

#### WHAT CAN HAPPEN

- **Driving on a street or roadway without such equipment is dangerous and can lead to accidents causing personal injury.**
- **Driving on a street or roadway without such equipment may also be a violation of State laws and the operator may be subject to traffic tickets and/or fines.**

#### HOW TO AVOID THE HAZARD

- **Do not drive machine on a public street or roadway.**

## Loading Machines

Use extreme caution when loading units on trailers or trucks. One full width ramp that is wide enough to extend beyond the rear tires is recommended instead of individual ramps for each side of the unit. The lower rear section of the tractor frame extends back between the rear wheels and serves as a stop for tipping backward. Having a full width ramp provides a surface for the frame members to contact if the unit starts to tip backward. If it is not possible to use one full width ramp, use enough individual ramps to simulate a full width continuous ramp.

Ramp should be long enough so that the angles between the ramp and the ground and the ramp and the trailer or truck do not exceed 15 degrees. A steeper angle may cause mower deck components to get caught as the unit moves from ramp to trailer or truck. Steeper angles may also cause the unit to tip backward. If loading on or near a slope, position the trailer or truck so it is on the down side of the slope and the ramp extends up the slope. This will minimize the ramp angle. The trailer or truck should be as level as possible.

**IMPORTANT: DO NOT attempt to turn the unit while on the ramp; you may lose control and drive off the side.**

Avoid sudden acceleration when driving up a ramp and sudden deceleration when backing down a ramp. Both maneuvers can cause the unit to tip backward.

 **WARNING****POTENTIAL HAZARD**

- Loading a unit on a trailer or truck increases the possibility of backward tip-over.

**WHAT CAN HAPPEN**

- Backward tip-over of the unit could cause serious injury or death.

**HOW TO AVOID THE HAZARD**

- Use extreme caution when operating a unit on a ramp.
- Use only a single, full width ramp; **DO NOT** use individual ramps for each side of the unit.
- If individual ramps must be used, use enough ramps to create an unbroken ramp surface wider than the unit.
- **DO NOT** exceed a 15 degree angle between ramp and ground or between ramp and trailer or truck.
- Avoid sudden acceleration while driving unit up a ramp to avoid tipping backward.
- Avoid sudden deceleration while backing unit down a ramp to avoid tipping backward.

## Tips for Mowing Grass

### Fast Throttle Setting

For best mowing and maximum air circulation, operate the engine at “FAST.” Air is required to thoroughly cut grass clippings, so do not set the height-of-cut so low as to totally surround the mower by uncut grass. Always try to have one side of the mower free from uncut grass, which allows air to be drawn into the mower.

### Cutting a Lawn for the First Time

Cut grass slightly longer than normal to ensure the cutting height of the mower does not scalp any uneven ground. However, the cutting height used in the past is generally the best one to use. When cutting grass longer than six inches tall, you may want to cut the lawn twice to ensure an acceptable quality of cut.

### Cut 1/3 of the Grass Blade

It is best to cut only about 1/3 of the grass blade. Cutting more than that is not recommended unless grass is sparse, or it is late fall when grass grows more slowly.

### Mowing Direction

Alternate mowing direction to keep the grass standing straight. This also helps disperse clippings which enhances decomposition and fertilization.

### Mow at Correct Intervals

Normally, mow every four days. But remember, grass grows at different rates at different times. So to maintain the same cutting height, which is a good practice, mow more often in early spring. As the grass growth rate slows in mid summer, mow less frequently. If you cannot mow for an extended period, first mow at a high cutting height; then mow again two days later at a lower height setting.

### Cutting Speed

To improve cut quality, use a slower ground speed in certain conditions.

### Avoid Cutting Too Low

If the cutting width of the mower is wider than the mower you previously used, raise the cutting height to ensure that uneven turf is not cut too short.

### Long Grass

If the grass is ever allowed to grow slightly longer than normal, or if it contains a high degree of moisture, raise the cutting height higher than usual and cut the grass at this setting. Then cut the grass again using the lower, normal setting.

### When Stopping

If the machine’s forward motion must be stopped while mowing, a clump of grass clippings may drop onto your lawn. To avoid this, move onto a previously cut area with the blades “ENGAGED”.

### Keep the Underside of the Mower Clean

Clean clippings and dirt from the underside of the mower after each use. If grass and dirt build up inside the mower, cutting quality will eventually become unsatisfactory.

### Blade Maintenance

Maintain a sharp blade throughout the cutting season because a sharp blade cuts cleanly without tearing or shredding the grass blades. Tearing and shredding turns grass brown at the edges, which slows growth and increases the chance of disease. Check the cutter blades daily for sharpness, and for any wear or damage. File down any nicks and sharpen the blades as necessary. If a blade is damaged or worn, replace it immediately with a genuine TORO replacement blade.

# Maintenance

## Service Interval Chart

Service Operation	Each Use	8 Hours	25 Hours	50 Hours	100 Hours	200 Hours	Storage Service
Hydraulic fluid—check level	Initial	Initial	X				X
Oil—check level	X						X
Oil—change*		Initial			X		X
Oil Filter—change (200 hours or every other oil change)*						X	X
Hydraulic filter—change		Initial				X	X
Safety System—check	X						X
Chassis—grease*			X				X
Linkage bushings—oil*			X				X
Foam Air Cleaner—service*			X				X
Paper Air Cleaner—replace*					X		X
Spark Plug(s)—check						X	X
Belts—check for wear/cracks				X			X
Gasoline—drain							X
Cooling systems—clean*	X				X		X
Hydraulic lines—check					X		X
Battery—check electrolyte			X				X
Battery—charge, Disconnect cables							X
Fuel Filter—replace						X	X
Tires—check pressure				X			X
Chipped Surfaces—paint							X
Cutting Blades—check		X					X
Blade Spindle Bearings—grease		X					
Mower Housing—clean	X						X
Castor Pivot – adjustment							500hrs or at Storage
Wheel Hub Slotted – adjustment							500hrs or at Storage
* More often in dusty, dirty conditions							

 **CAUTION**

**POTENTIAL HAZARD**

- If you leave the key in the ignition switch, someone could start the engine.

**WHAT CAN HAPPEN**

- Accidental starting of the engine could seriously injure you or other bystanders.

**HOW TO AVOID THE HAZARD**

- Remove the key from the ignition switch and pull the wire(s) off the spark plug(s) before you do any maintenance. Also push the wire(s) aside so it does not accidentally contact the spark plug(s).

## Cutting Blades

Maintain sharp blades throughout the cutting season because sharp blades cut cleanly without tearing or shredding the grass blades. Tearing and shredding turns grass brown at the edges, which slows growth and increases the chance of disease.

Check the cutter blades daily for sharpness, and for any wear or damage. File down any nicks and sharpen the blades as necessary. If a blade is damaged or worn, replace it immediately with a genuine TORO replacement blade. For convenient sharpening and replacement, you may want to keep extra blades on hand.

## Before Inspecting or Servicing the Blades

Park the machine on a level surface, disengage the blade control (PTO) and set the parking brake. Turn the ignition key to “OFF” to stop the engine. Remove the key and disconnect the spark plug wire(s) from the spark plug(s).

 **WARNING**

**POTENTIAL HAZARD**

- A blade that is worn or damaged could break apart and pieces could be thrown at bystanders or at you as you use the mower.

**WHAT CAN HAPPEN**

- Pieces of blade that may be thrown could seriously injure or kill you or bystanders.

**HOW TO AVOID THE HAZARD**

- Periodically inspect the blade for wear and damage. Immediately install a new blade if it is worn or damaged.

## Inspecting the Blades

1. Inspect the cutting edges (Fig 15). If the edges are not sharp or have nicks, remove and sharpen the blades. Refer to Sharpening the Blades on page 38.
2. Inspect the blades, especially the curved area (Fig. 15). If you notice any damage, wear, or a slot forming in this area (item 3 in Fig. 15), immediately install a new blade.

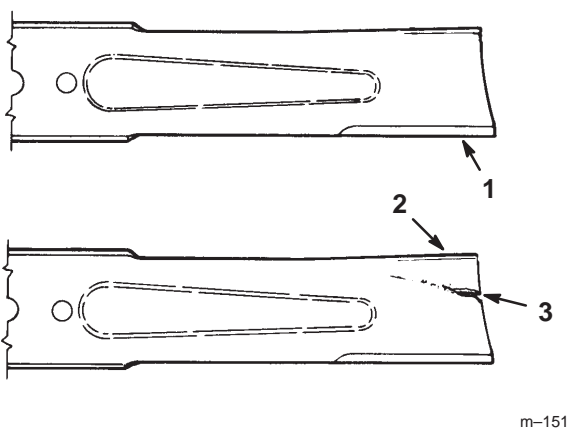

Figure 15

- |                 |                      |
|-----------------|----------------------|
| 1. Cutting Edge | 3. Wear/slot Forming |
| 2. Curved Area  |                      |

## Checking for Bent Blades

1. Rotate the blades until the ends face forward and backward (Fig. 16). Measure from a level surface to the cutting edge of the blades (Fig. 17). Note this dimension.

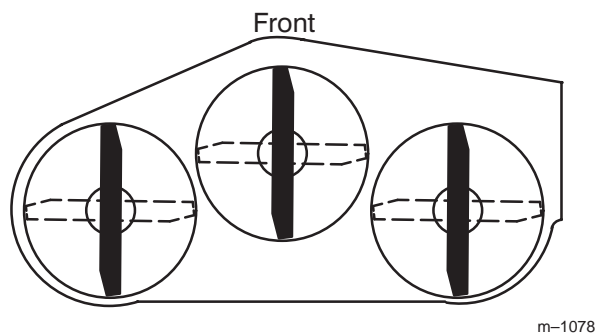
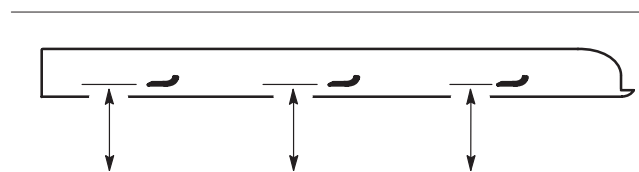

Figure 16



MEASURE FROM  
CUTTING EDGE TO A  
LEVEL SURFACE

Figure 17

2. Rotate the opposite ends of the blades forward. Measure from a level surface to the cutting edge of the blades at the same position as in step 1 above. The difference between the dimensions obtained in steps 1 and 2 must not exceed 1/8" (3 mm). If this dimension exceeds 1/8" (3 mm), the blade is bent and must be replaced. Refer to Removing the Blades, and Installing the Blades on page 39.

**! WARNING**

**POTENTIAL HAZARD**

- A blade that is bent or damaged could break apart and pieces could be thrown at bystanders or at you as you use the mower.

**WHAT CAN HAPPEN**

- Pieces of blade that may be thrown could seriously injure or kill you or bystanders.

**HOW TO AVOID THE HAZARD**

- Always replace bent or damaged blade with a new blade.
- Never file or create sharp notches in the edges or surfaces of blade.

### Removing the Blades

Blades must be replaced if a solid object is hit, if the blade is out of balance or is bent. To ensure optimum performance and continued safety conformance of the machine, use genuine TORO replacement blades. Replacement blades made by other manufacturers may result in non-conformance with safety standards.

**! WARNING**

**POTENTIAL HAZARD**

- Blade is sharp.

**WHAT CAN HAPPEN**

- Contact with sharp blade can cause serious personal injury.

**HOW TO AVOID THE HAZARD**

- Wear gloves or wrap sharp edges of the blade with a rag.

1. Hold the blade end using a rag or thickly-padded glove. Remove the blade bolt, spring disk and blade from the spindle shaft (Fig. 20).

### Sharpening the Blades

**! WARNING**

**POTENTIAL HAZARD**

- When sharpening blade, pieces of blade could be accidentally thrown.

**WHAT CAN HAPPEN**

- Thrown objects can cause serious eye injury.

**HOW TO AVOID THE HAZARD**

- Wear proper eye protection when sharpening blade.

1. Use a file to sharpen the cutting edge at both ends of the blade (Fig. 18). Maintain the original angle. The blade retains its balance if the same amount of material is removed from both cutting edges.

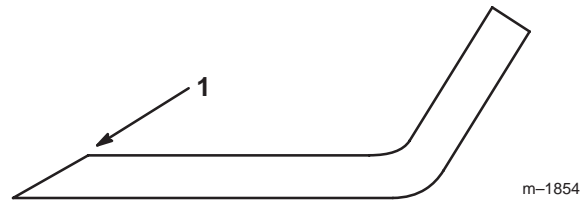

**Figure 18**

1. Sharpen at original angle

2. Check the balance of the blade by putting it on a blade balancer (Fig. 19). If the blade stays in a horizontal position, the blade is balanced and can be used. If the blade is not balanced, file some metal off the end of the sail area only (Fig. 20). Repeat this procedure until the blade is balanced.

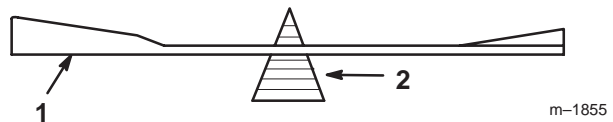

**Figure 19**

1. Blade
2. Balancer

## Installing the Blades

1. Install the blade onto the spindle shaft (Fig. 20).

**IMPORTANT:** The curved part of the blade must be pointing upward toward the inside of the mower to ensure proper cutting.

2. Install the spring disk and blade bolt (Fig. 20). Torque the blade bolt to 85–110 ft-lb (115–150 N•m).

**IMPORTANT:** Make sure blade is torqued to 85–110 ft-lb (115–150 N•m).

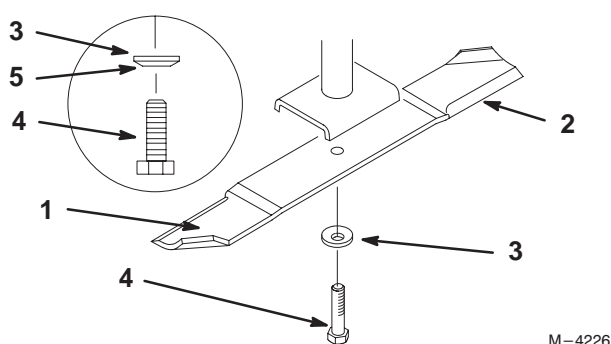

M-4226

**Figure 20**

- |                       |                           |
|-----------------------|---------------------------|
| 1. Sail Area of Blade | 4. Blade Bolt             |
| 2. Blade              | 5. Cone Towards Bolt Head |
| 3. Spring Disk        |                           |

## Air Cleaner

Foam Element: Clean and re-oil after every 25 operating hours.

Paper Element: Replace after every 100 operating hours.

**Note:** Service the air cleaner more frequently (every few hours) if operating conditions are extremely dusty or sandy.

## Removing the Foam and Paper Elements

1. Disengage the power take off (PTO), set the parking brake, and turn the ignition key to “OFF” to stop the engine. Remove the key.
2. Clean around the air cleaner to prevent dirt from getting into the engine and causing damage. Unscrew the knob and remove the air cleaner cover (Fig. 21).

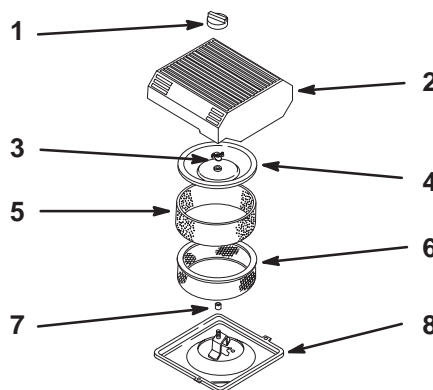

m-3214

**Figure 21**

- |                      |                     |
|----------------------|---------------------|
| 1. Knob              | 5. Foam element     |
| 2. Air cleaner cover | 6. Paper element    |
| 3. Cover nut         | 7. Rubber seal      |
| 4. Cover             | 8. Air cleaner base |

3. Carefully slide the foam element off the paper element (Fig. 21).
4. Unscrew the cover nut and remove the cover and paper element (Fig. 21).

### Cleaning the Foam and Paper Elements

#### 1. Foam Element

- A. Wash the foam element in liquid soap and warm water. When the element is clean, rinse it thoroughly.
- B. Dry the element by squeezing it in a clean cloth (do not wring).
- C. Put one or two ounces of oil on the element (Fig. 22). Squeeze the element to distribute the oil.

**IMPORTANT: Replace the foam element if it is torn or worn.**

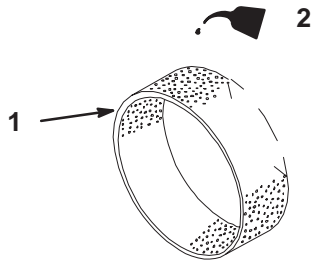

Figure 22

1. Foam element
  2. Oil
- 

#### 2. Paper Element

- A. Lightly tap the element on a flat surface to remove dust and dirt (Fig. 23).
- B. Inspect the element for tears, an oily film, and damage to the rubber seal.

**IMPORTANT: Never clean the paper element with pressurized air or liquids, such as solvent, gas, or kerosene. Replace the paper element if it is damaged, or cannot be cleaned thoroughly.**

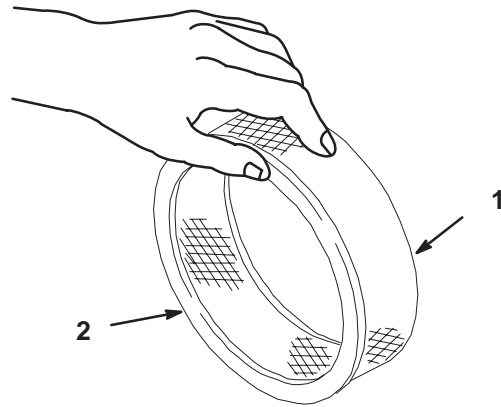

m-1213

Figure 23

1. Paper element
  2. Rubber seal
- 

### Installing the Foam and Paper Elements

#### 1. Installing the Foam and Paper Elements

**IMPORTANT: To prevent engine damage, always operate the engine with the complete foam and paper air cleaner assembly installed.**

1. Carefully slide the foam element onto the paper air cleaner element (Fig. 21).
2. Place the air cleaner assembly onto the air cleaner base (Fig. 21).
3. Install the air cleaner cover and secure with cover nut (Fig. 21).

## Engine Oil

Change oil:

- After the first 8 operating hours.
- After every 100 operating hours.

**Note:** Change oil more frequently when operating conditions are extremely dusty or sandy.

Oil Type: Detergent oil (API service SG or SH)

Crankcase Capacity: w/filter, 2.1 qt. (2 l)

Viscosity: See table below

### USE THESE SAE VISCOSITY OILS

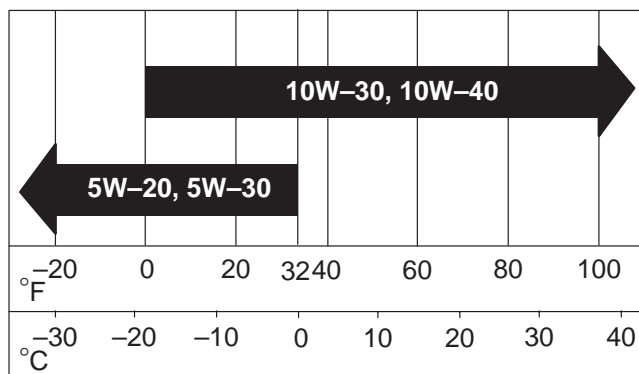

## Checking Oil Level

**Note:** Check oil when engine is cold.

1. Disengage the power take off (PTO) and turn the ignition key to “OFF” to stop the engine. Move controllers to neutral locked position and apply parking brake. Remove the key.
2. Clean around the oil dipstick (Fig. 24) so dirt cannot fall into the filler hole and damage the engine.
3. Pull the oil dipstick out and wipe the metal end clean (Fig. 24).
4. Slide the oil dipstick fully into the filler tube. Pull the dipstick out and look at the metal end (Fig. 24). If oil level is low, slowly pour only enough oil into the filler tube to raise the level to the “FULL” mark.

**IMPORTANT:** Do not overfill the crankcase with oil because the engine may be damaged. Do not run engine with oil below the low mark because the engine may be damaged.

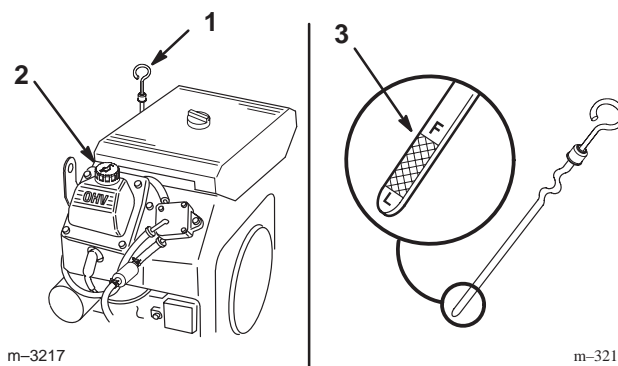

Figure 24

1. Oil dipstick
2. Filler tube
3. Metal end

## Changing/Draining Oil

1. Start the engine and let it run five minutes. This warms the oil so it drains better.
2. Park the machine so that the drain side is slightly lower than the opposite side to assure the oil drains completely. Disengage the power take off (PTO), set the parking brake, and turn the ignition key to "OFF" to stop the engine. Remove the key.
3. Place a pan below the oil drain. Remove the oil drain plug (Fig. 25).
4. When oil has drained completely, install the drain plug.

**Note:** Dispose of the used oil at a certified recycling center.

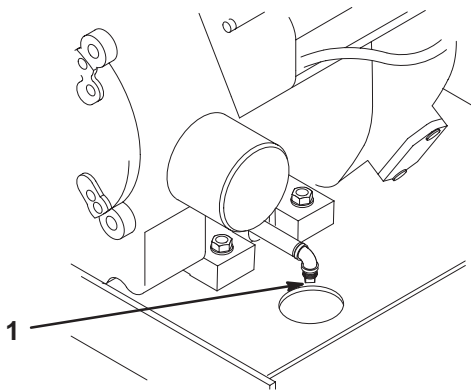

Figure 25

1. Oil drain plug

5. Slowly pour approximately 80% of the specified amount of oil specified, page 41, into the filler tube (Fig. 25). Now check the oil level; refer to Checking Oil Level, page 41. Slowly add additional oil to bring to "FULL" mark on dipstick.

## Change Oil Filter

Replace the oil filter every 200 hours or every other oil change.

**Note:** Change oil filter more frequently when operating conditions are extremely dusty or sandy.

1. Drain the oil from the engine; refer to Changing/Draining Oil, page 42.
2. Remove the old filter and wipe the filter adapter (Fig. 26) gasket surface.
3. Pour new oil of the proper type in through the center hole. Stop pouring when the oil reaches the bottom of the threads. Allow a minute or two for the oil to be absorbed by filter material.
4. Apply a thin coat of new oil to the rubber gasket on the replacement filter (Fig. 26).

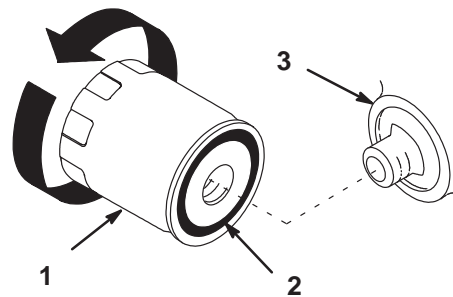

Figure 26

1. Oil filter
2. Gasket
3. Adapter

5. Install the replacement oil filter to the filter adapter. Turn the oil filter clockwise until the rubber gasket contacts the filter adapter, then tighten the filter an additional 1/2 turn (Fig. 26).
6. Fill the crankcase with the proper type of new oil; refer to Changing/Draining Oil, page 42.

## Spark Plug

Check the spark plug(s) after every 200 operating hours. Make sure the air gap between the center and side electrodes is correct before installing the spark plug. Use a spark plug wrench for removing and installing the spark plug(s) and a gapping tool/feeler gauge to check and adjust the air gap. Install a new spark plug(s) if necessary.

Type: Champion RC12YC (or equivalent) Air Gap: 0.030 in. (0.76 mm)

### Removing the Spark Plug(s)

1. Disengage the power take off (PTO) and turn the ignition key to "OFF" to stop the engine. Move controllers to neutral locked position and apply parking brake. Remove the key.
2. Pull the wire(s) off the spark plug(s) (Fig. 27). Now clean around the spark plug(s) to prevent dirt from falling into the engine and potentially causing damage.
3. Remove the spark plug(s) and metal washer.

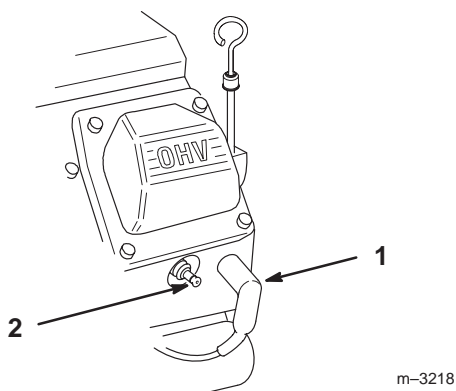

**Figure 27**

1. Spark plug wire
2. Spark plug

### Checking the Spark Plug

1. Look at the center of the spark plug(s) (Fig. 28). If you see light brown or gray on the insulator, the engine is operating properly. A black coating on the insulator usually means the air cleaner is dirty.

**IMPORTANT: Never clean the spark plug(s). Always replace the spark plug(s) when it has: a black coating, worn electrodes, an oily film, or cracks.**

2. Check the gap between the center and side electrodes (Fig. 28). Bend the side electrode if the gap is not correct.

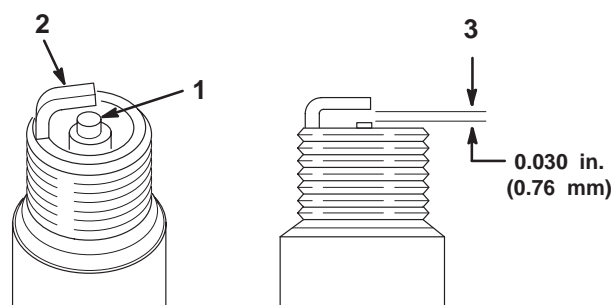

m-3215

**Figure 28**

1. Center electrode insulator
2. Side electrode
3. Air gap (not to scale)

### Installing the Spark Plug(s)

1. Install the spark plug(s). Make sure the air gap is set correctly.
2. Tighten the spark plug(s) to 20 ft-lb (27 N.m).
3. Push the wire(s) onto the spark plug(s) (Fig. 27).

## Fuel Filter

Replace the fuel filter after every 200 operating hours or yearly, whichever occurs first.

### Replacing the Fuel Filter

Never install a dirty filter if it is removed from the fuel line.

1. Disengage the power take off (PTO) and turn the ignition key to “OFF” to stop the engine. Move controllers to neutral locked position and apply parking brake. Remove the key.
2. Close fuel shut-off valve on console.
3. Squeeze the ends of the hose clamps together and slide them away from the filter (Fig. 29).
4. Remove the filter from the fuel lines.
5. Install a new filter and move the hose clamps close to the filter (Fig. 29).
6. Wipe up any spilled fuel.
7. Open fuel shut-off valve on console.

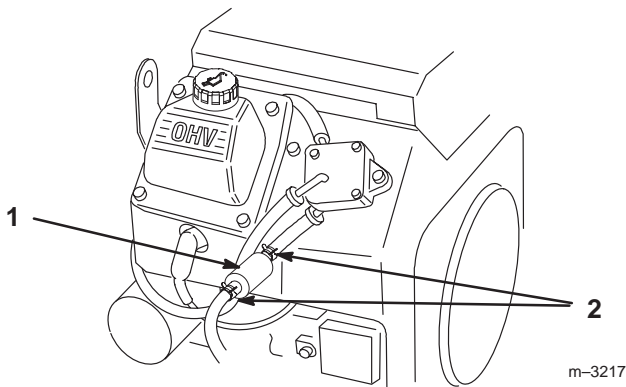

Figure 29

1. Filter

2. Hose clamp

## Fuel Tank

### Draining The Fuel Tank

#### DANGER

##### POTENTIAL HAZARD

- In certain conditions gasoline is extremely flammable and highly explosive.

##### WHAT CAN HAPPEN

- A fire or explosion from gasoline can burn you, others, and cause property damage.

##### HOW TO AVOID THE HAZARD

- Drain gasoline from the fuel tank when the engine is cold. Do this outdoors in an open area. Wipe up any gasoline that spills.
- Never drain gasoline near an open flame or where gasoline fumes may be ignited by a spark.
- Never smoke a cigarette, cigar or pipe.

1. Park the machine on a level surface, to assure fuel tank drains completely. Then disengage the power take off (PTO), set the parking brake, and turn the ignition key to “OFF” to stop the engine. Remove the key.
2. Close fuel shut-off valve (Fig. 30).
3. Loosen the hose clamp at the fuel filter and slide it up the fuel line away from the fuel filter (Fig. 30).

- Pull the fuel line off fuel filter (Fig. 30). Open fuel shut-off valve and allow gasoline to drain into a gas can or drain pan.

**Note:** Now is the best time to install a new fuel filter because the fuel tank is empty.

- Install the fuel line onto the fuel filter. Slide the hose clamp close to the fuel filter to secure the fuel line (Fig. 30).

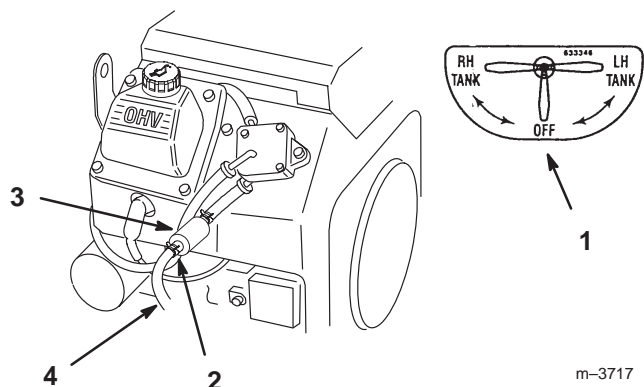

**Figure 30**

- |                        |               |
|------------------------|---------------|
| 1. Fuel shut-off valve | 3. Hose clamp |
| 2. Fuel filter         | 4. Fuel line  |

## Greasing and Lubrication

Lubricate the machine when shown on the CHECK SERVICE REFERENCE AID decal (Fig. 31). Grease more frequently when operating conditions are extremely dusty or sandy.

Grease Type: General-purpose grease.

### How to Grease

- Disengage the power take off (PTO) and turn the ignition key to "OFF" to stop the engine. Move controllers to neutral locked position and apply parking brake. Remove the key.
- Clean the grease fittings with a rag. Make sure to scrape any paint off the front of the fitting(s).
- Connect a grease gun to the fitting. Pump grease into the fittings until grease begins to ooze out of the bearings.
- Wipe up any excess grease.

### Grease Front Castor Pivots

Lubricate the front castor pivots once a year.

- Remove hex plug and cap. Thread a grease zerk into hole.
- Pump grease into zerk until it oozes out around top bearing.
- Remove grease zerk in hole. Reinstall hex plug and cap.

## Where to Add Grease

Lubricate the grease fittings as shown on the CHECK SERVICE REFERENCE AID decal (Fig. 31).

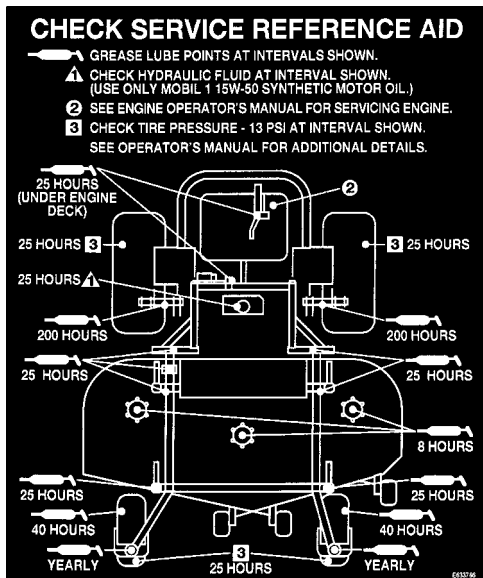

Figure 31

## Where to Add Light Oil or Spray Lubrication

Lubricate the machine in the following areas with spray type lubricant or light oil.

- Seat switch actuator.
- Brake handle pivot.
- Brake rod bushings.
- Motion control bronze bushings.

## Greasing the Bearings

The cutting unit must be lubricated regularly. Refer to the Service Interval Chart on page 35. Grease with No. 2 general purpose lithium base or molybdenum base grease.

1. Stop the engine, set the parking brake, remove the key and disconnect the spark plug wire(s) from the spark plug(s).
2. Grease the fittings on the three spindle bearings (Fig. 32).
3. Grease the fittings on the push arms (Fig. 32).

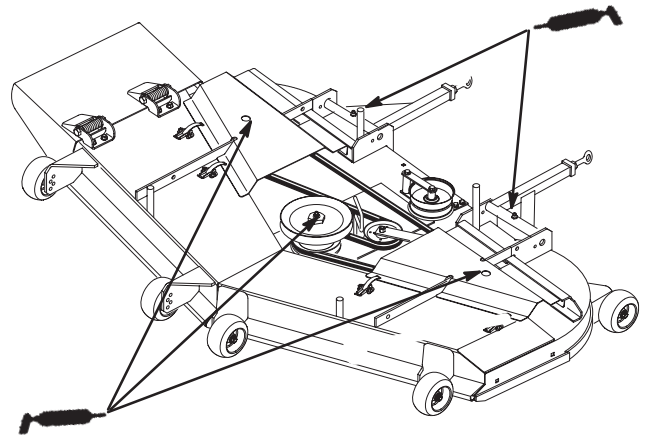

m-4459

Figure 32

## Cleaning the Cooling Systems

Before each use, check and clean cooling screen. Remove any build-up of grass, dirt or other debris from the oil cooler screen and engine air intake. Every 100 hours clean oil cooler, engine cylinder and cylinder head cooling fins. Also clean around carburetor, governor levers and linkage. This will help insure adequate cooling to hydraulic pumps, motors and engine and will reduce the possibility of overheating and mechanical damage.

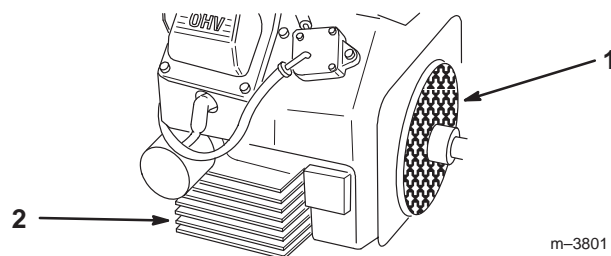

**Figure 33**

1. Engine screen                      2. Oil cooler

## Tire Pressure

Maintain the air pressure in the front and rear tires as specified. Uneven tire pressure can cause uneven cut. Check the pressure at the valve stem after every 50 operating hours or monthly, whichever occurs first (Fig. 34). Check the tires when they are cold to get the most accurate pressure reading.

Pressure: 13 psi (90 kPa) drive wheels and castor wheels.

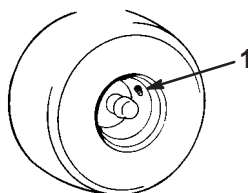

**Figure 34**

1. Valve stem

## Wheel Hub Slotted Nut

Check after every 500 operating hours.

The slotted nut needs to be torqued to 125 ft-lbs (169.5 N•m).

1. Stop the engine, set the parking brake, remove the key and disconnect the spark plug wire(s) from the spark plug(s).
2. Remove cotter pin.
3. Torque slotted nut to 125 ft-lbs (169.5 N•m) (Fig. 35).
4. Check the distance from bottom of slot in nut to inside edge of hole. Two threads or less should be showing (Fig. 35).
5. If more than two threads are showing remove nut and install washer between hub and nut (Fig. 35).
6. Torque the slotted nut to 125 ft-lbs (169.5 N•m) (Fig. 35).
7. Tighten nut until the next set of slots line up with the hole in the shaft (Fig. 35).
8. Replace cotter pin.

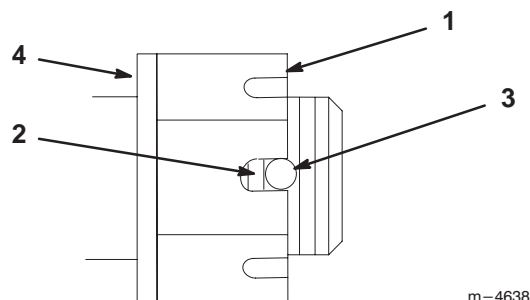

**Figure 35**

- |                                |                         |
|--------------------------------|-------------------------|
| 1. Slotted Nut                 | 3. Hole in threaded rod |
| 2. Two threads or less showing | 4. Washer (if needed)   |

## Castor Pivot Bearing Adjustment

Check after every 500 operating hours or at storage, which ever comes first.

1. Stop the engine, set the parking brake, remove the key and disconnect the spark plug wire(s) from the spark plug(s).
2. Remove dust cap from castor and tighten lock nut (Fig. 36).
3. Tighten until spring washers are flat and then back off a 1/4 turn to properly set the pre-load on the bearings (Fig. 36).

**IMPORTANT: Make sure spring washers are installed correctly as shown in figure 36.**

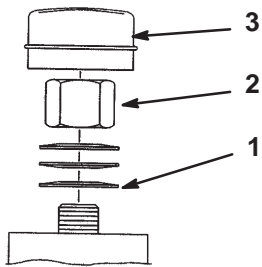

M-4640

**Figure 36**

1. Spring Washers
2. Lock Nut
3. Dust Cap

## Hydraulic System

### Checking the Hydraulic Fluid

Check the hydraulic fluid level before engine is first started. If there is no fluid, add fluid to reservoir approximately a 1/4" (6mm) below the top of baffle.

Check the hydraulic fluid level after first 8 operating hours.

Check the hydraulic fluid level after every 25 operating hours.

Fluid Type: Mobil 1 15W-50 synthetic motor oil.

**IMPORTANT: Use only oil specified. Other fluids could cause system damage.**

System Capacity: 2.1 qt. (2.0 l)

1. Position machine on a level surface, stop the engine and set the parking brake.
2. Clean area around filler neck of hydraulic tank (Fig. 37).
3. Remove cap from filler neck. Look inside to check if there is fluid in the reservoir. (Fig. 37).
4. If there is no fluid, add fluid to reservoir approximately a 1/4" (6mm) below the top of baffle.
5. Run the machine 15 minutes to allow any air to purge out of the system and warm fluid.
6. Recheck level while fluid is warm. Add fluid to raise level to top of the baffle, if required.  
**Note:** Fluid level should be to the top of the baffle when fluid is warm (Fig. 37).
7. Install cap on filler neck.

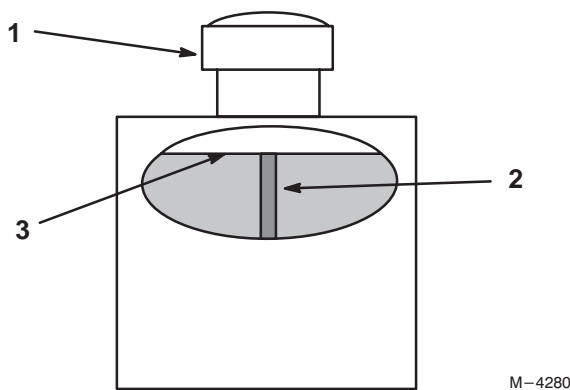

Figure 37

1. Cap  
2. Baffle  
3. Fluid level-Full

## ⚠ WARNING

### POTENTIAL HAZARD

- Hydraulic fluid escaping under pressure can penetrate skin and cause injury.

### WHAT CAN HAPPEN

- Fluid accidentally injected into the skin must be surgically removed within a few hours by a doctor familiar with this form of injury or gangrene may result.

### HOW TO AVOID THE HAZARD

- Make sure all hydraulic fluid hoses and lines are in good condition and all hydraulic connections and fittings are tight before applying pressure to hydraulic system.
- Keep body and hands away from pin hole leaks or nozzles that eject high pressure hydraulic fluid.
- Use cardboard or paper to find hydraulic leaks.
- Safely relieve all pressure in the hydraulic system before performing any work on the hydraulic system.

## Replacing the Hydraulic Filter

Change the hydraulic filter:

- After the first 8 operating hours.
  - After every 200 operating hours.
- Disengage the power take off (PTO) and turn the ignition key to “OFF” to stop the engine. Move controllers to neutral locked position and apply parking brake. Remove the key.

**IMPORTANT: Do not substitute automotive oil filter or severe hydraulic system damage may result.**

- Remove hydro cap and temporarily cover opening with a plastic bag and rubber band to prevent all hydro fluid from draining out.
- Place drain pan under filter, remove the old filter and wipe the filter adapter gasket surface clean (Fig. 38).

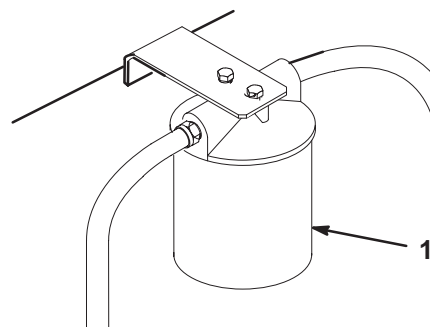

Figure 38

1. Hydraulic filter

- Apply a thin coat hydro fluid to the rubber gasket on the replacement filter (Fig. 39).
- Install replacement hydraulic filter onto the filter adapter. Do not tighten.
- Remove plastic bag from tank opening and allow filter to fill with hydro fluid.

M-4763

7. When fluid overflows filter turn the oil filter clockwise until the rubber gasket contacts the filter adapter, then tighten the filter an additional 1/2 turn (Fig. 39).
8. Clean up any spilled fluid.
9. Start engine and let run for about two minutes to purge air from the system. Stop the engine and check for leaks. If one or both wheels will not drive, refer Bleeding Hydraulic System, page 50.
10. Check fluid level in hydraulic tank and add to raise level to top of baffle. **DO NOT OVER FILL.**

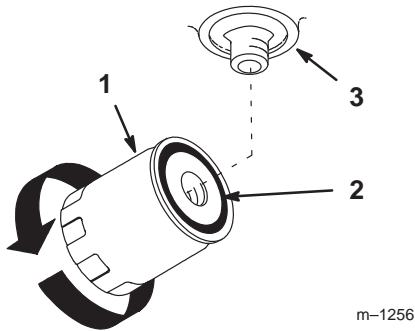

Figure 39

1. Hydraulic filter
2. Gasket
3. Adapter

## Bleeding Hydraulic System

The traction system is self bleeding, however, it may be necessary to bleed the system if fluid is changed or after work is performed on the system.

1. Raise rear of the machine so wheels are off the ground and support with jack stands.
2. Start the engine and run at idle speed. Engage traction on one side and spin the wheel by hand.
3. When the wheel begins to spin on its own, keep it engaged until wheel drives smoothly. (minimum 2 minute)
4. Check hydraulic fluid level as it drops and add as required to maintain proper level.
5. Repeat procedure on opposite wheel.

## Check Hydraulic Lines

After every 100 operating hours, check hydraulic lines and hoses for leaks, loose fittings, kinked lines, loose mounting supports, wear, weather and chemical deterioration. Make necessary repairs before operating.

**Note:** Keep areas around hydraulic system clean from grass and debris build up.

### **WARNING**

#### POTENTIAL HAZARD

- Hydraulic fluid escaping under pressure can penetrate skin and cause injury.

#### WHAT CAN HAPPEN

- Fluid accidentally injected into the skin must be surgically removed within a few hours by a doctor familiar with this form of injury or gangrene may result.

#### HOW TO AVOID THE HAZARD

- Make sure all hydraulic fluid hoses and lines are in good condition and all hydraulic connections and fittings are tight before applying pressure to hydraulic system.
- Keep body and hands away from pin hole leaks or nozzles that eject high pressure hydraulic fluid.
- Use cardboard or paper to find hydraulic leaks.
- Safely relieve all pressure in the hydraulic system before performing any work on the hydraulic system.

## Adjusting Motion Controls

### Adjusting Handle Neutral

If motion control levers do not align, or move easily into the console notch, adjustment is required. Adjust each lever, spring and rod separately.

**Note:** Motion control levers must be installed correctly. See Install Motion Control Levers on page 19.

1. Stop engine, remove ignition key and tilt seat forward.
2. Begin with either the left or right motion control lever. Move lever to the neutral (but not locked) position and pull lever back until the clevis pin (on arm below pivot shaft) contacts the end of the slot (just beginning to put pressure on spring) (Fig. 40).
3. Check where lever is relative to notch in console (should be centered allowing lever to pivot outward to the neutral lock position) (Fig. 40).
4. If adjustment is needed, loosen the nut against the yoke.
5. Apply slight rearward pressure on the motion control lever, turn the head of the adjustment bolt in the appropriate direction until lever is centered in neutral lock position (keeping rearward pressure on the lever will keep the pin at the end of the slot and allow the adjustment bolt to move the lever to the appropriate position).
6. Tighten nut and jam nut.
7. Repeat on opposite side of unit.

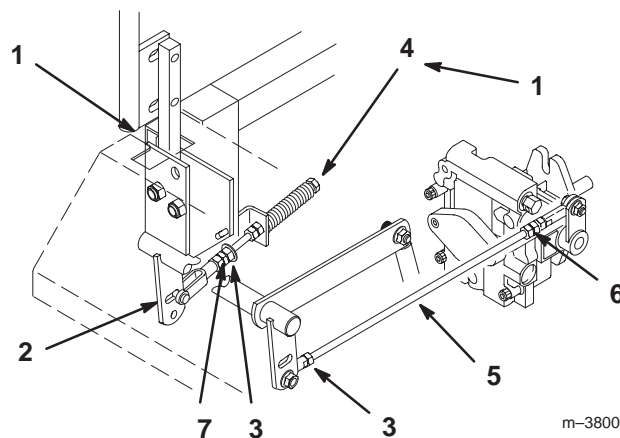

**Figure 40**

- |                          |                |
|--------------------------|----------------|
| 1. Neutral lock position | 5. Pump rod    |
| 2. Clevis pin in slot    | 6. Double nuts |
| 3. Nut                   | 7. Jam Nut     |
| 4. Bolt                  |                |

### Adjusting Hydraulic Pump Neutral

**Note:** Adjust handle neutral first. That has to be correct before the following adjustment can be made.

#### CAUTION

##### POTENTIAL HAZARD

- Mechanical or hydraulic jacks may not support machine.

##### WHAT CAN HAPPEN

- Weight of machine can cause hydraulic jacks to fail and cause an injury.

##### HOW TO AVOID THE HAZARD

- Use jack stands when supporting machine.
- Do not use hydraulic jacks.

1. This adjustment must be made with drive wheels turning. First raise the frame and block up so drive wheels can rotate freely.

 **WARNING**

**POTENTIAL HAZARD**

- Engine must be running so motion control adjustment can be performed.

**WHAT CAN HAPPEN**

- Contact with moving parts or hot surfaces may cause personal injury.

**HOW TO AVOID THE HAZARD**

- Keep hands, feet, face, clothing and other body parts away from rotating parts, muffler and other hot surfaces.

2. Slide seat forward, disconnect prop rod and tilt seat fully forward.
3. Disconnect electrical connector from the seat safety switch. *Temporarily* install a jumper wire across terminals in the wiring harness connector.
4. Loosen locknut at ball joint on pump control rod (Fig. 40).

**Note:** The front nut of each rod has left-hand threads.

5. Start engine, open throttle 1/2 way and release parking brake. Refer to Starting and Stopping the Engine, page 25.
6. Adjust pump rod length by rotating double nuts on rod, in the appropriate direction, until wheel is still or slightly creeps in reverse (Fig. 40).
7. Move motion control lever forward and reverse, then back to neutral. Wheel must stop turning or slightly creep in reverse.  
**Note:** Motion control lever must be in neutral while making any adjustments.
8. Open throttle to fast. Make sure wheel remains stopped or slightly creeps in reverse, re-adjust if necessary.

9. Repeat on opposite side of unit. Tighten locknuts against ball joints.

 **WARNING**

**POTENTIAL HAZARD**

- Electrical system will not perform proper safety shut off with jumper wire installed.

**WHAT CAN HAPPEN**

- Contact with moving parts may cause personal injury.

**HOW TO AVOID THE HAZARD**

- Remove jumper wire from wire harness connector and plug connector into seat switch when adjustment is completed.
- Never operate this unit with jumper installed and seat switch bypassed.

10. Shut off unit. Remove jumper wire from wire harness connector and plug connector into seat switch.
11. Reinstall prop rod and lower seat.
12. Remove jack stands.

## Replacing the Pump Drive Belt

Check pump drive belt for wear after every 50 hours of operation.

1. Pull spring loaded idler down and remove traction belt from the engine and hydro pump pulleys (Fig. 41). Remove belt between pulleys.
2. Install new belt around engine and hydro pump pulleys (Fig. 41).
3. Pull spring loaded idler down and align below traction belt. Release pressure on spring loaded idler (Fig. 41).

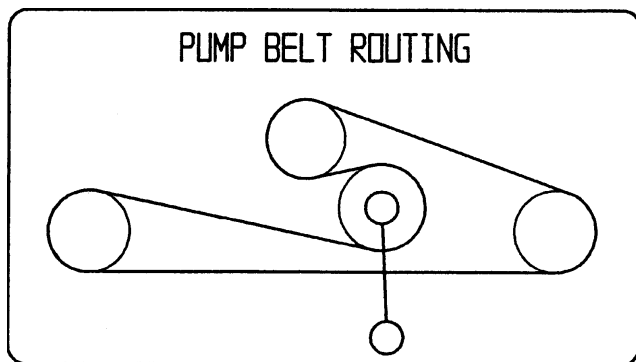
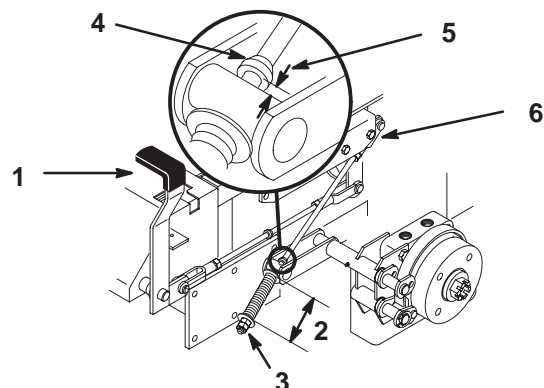

Figure 41

## Adjustment Parking Brake

Check parking brake for proper adjustment.

1. Disengage brake lever (lever down).
2. Measure the length of the spring. Measurement should be 2.75" (70 mm) between washers (Fig. 42).
3. If adjustment is necessary, loosen the jam nut below the spring and tighten the nut directly below the yoke (Fig. 42). Turn the nut until the correct measurement is obtained. Tighten the two nuts together and repeat on opposite side of unit.
4. Turn nuts clockwise to shorten spring length and turn counter-clockwise to lengthen the spring.
5. Engage parking brake, lever up.
6. Measure the distance between the trunnion roller and the collar on brake rod. Measurement should be 3/16"–1/4" (5–7 mm) (Fig. 42).
7. If adjustment is necessary, loosen the jam nut directly below the yoke. Turn the bottom rod until the correct measurement is obtained (Fig. 42). Tighten jam nut at yoke



m-3788

Figure 42

- |                         |                        |
|-------------------------|------------------------|
| 1. Brake lever          | 4. Collar on brake rod |
| 2. Spring 2.75" (70 mm) | 5. 3/16"–1/4" (5–7 mm) |
| 3. Adjusting nuts       | 6. Jam nut and yoke    |

## Throttle Lever Adjustment

The tension can be adjusted by adjusting the tightness of lever pivot bolt. Do this when needed.

1. Stop engine, remove ignition key.
2. Remove console from machine to gain access to throttle lever.
3. Tighten nut and bolt. Test lever to your desired tension (Fig. 43).

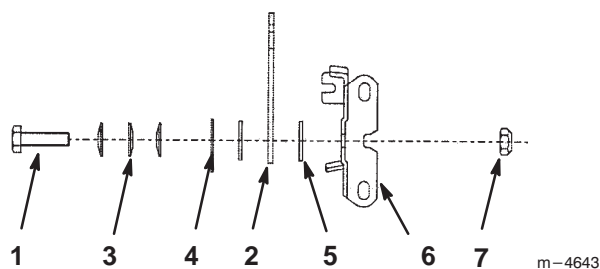

m-4643

Figure 43

- |                       |            |
|-----------------------|------------|
| 1. Pivot Bolt         | 5. Washer  |
| 2. Throttle Lever     | 6. Bracket |
| 3. Belleville Washers | 7. Nut     |
| 4. Tab Washer         |            |

## Fuse

### Service Interval/Specification

The electrical system is protected by fuses. It requires no maintenance, however, if a fuse blows check component/circuit for malfunction or short.

Fuse: Main F1–20 amp, blade-type  
Alternator F2–20 amp, blade-type

1. Raise the seat to gain access to fuse holder (Fig. 44).
2. To replace fuses pull out on the fuse to remove it (Fig. 44).

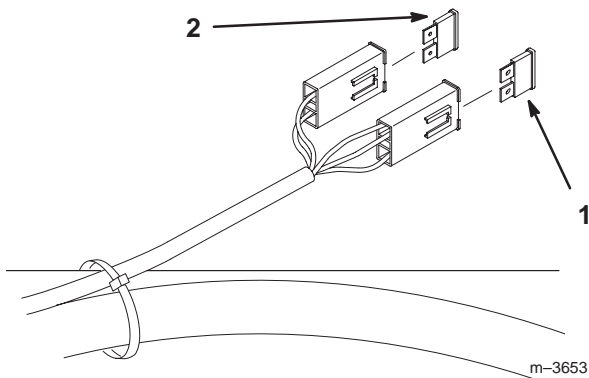

**Figure 44**

1. Main-20 amp
2. Alternator-20 amp

## Battery

Check the electrolyte level in the battery every 25 hours. Always keep the battery clean and fully charged. Use a paper towel to clean the battery case. If the battery terminals are corroded, clean them with a solution of four parts water and one part baking soda. Apply a light coating of grease to the battery terminals to prevent corrosion.

Voltage: 12 v

### Checking Electrolyte Level

1. Open covers to see into the cells. The electrolyte must be up to the lower part of the tube (Fig. 45). Do not allow the electrolyte to get below the plates. (Fig. 45).
2. If the electrolyte is low, add the required amount of distilled water; refer to Adding Water to the Battery, page 54.

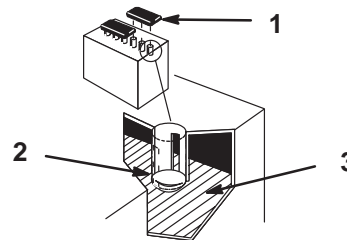

**Figure 45**

1. Filler caps
2. Lower part of tube
3. Plates

### Adding Water to the Battery

The best time to add distilled water to the battery is just before you operate the machine. This lets the water mix thoroughly with the electrolyte solution.

1. Clean the top of the battery with a paper towel.
2. Lift off the filler caps (Fig. 45).
3. Slowly pour distilled water into each battery cell until the level is up to the lower part of the tube (Fig. 45).

**IMPORTANT: Do not overfill the battery because electrolyte (sulfuric acid) can cause severe corrosion and damage to the chassis.**

4. Press the filler caps onto the battery.
5. Position drain tube away from belts and other parts to prevent corrosion.

## Charging the Battery

**IMPORTANT: Always keep the battery fully charged (1.260 specific gravity). This is especially important to prevent battery damage when the temperature is below 32°F (0°C).**

1. Check the electrolyte level; refer to Checking Electrolyte Level, page 54.
2. Remove the filler caps from the battery and connect a 3 to 4 amp battery charger to the battery posts. Charge the battery at a rate of 4 amperes or less for 4 hours (12 volts). Do not overcharge the battery. Install the filler caps after the battery is fully charged.

### WARNING

#### POTENTIAL HAZARD

- Charging the battery produces gasses.

#### WHAT CAN HAPPEN

- Battery gasses can explode.

#### HOW TO AVOID THE HAZARD

- Keep cigarettes, sparks and flames away from battery.

## Mower Leveling

1. Position mower on a flat surface. Stop the engine, set the parking brake, remove the key and disconnect the spark plug wire(s) from the spark plug(s).
2. Check tire pressure of all four (4) tires. If needed, adjust to 13 psi (90 kPa)
3. Set anti-scalp rollers to top holes or remove them completely for this adjustment.
4. Raise the deck to the transport position and take all force off of the two large deck lift springs by loosening nut in front of each spring (Fig. 46).
5. Place two 2" (51 mm) thick blocks under rear left and right lower edge of mower. Place one 2-1/4" (57 mm) block under front center lower edge of mower. Lower mower to the 2" (51 mm) height-of-cut position (Fig. 46).

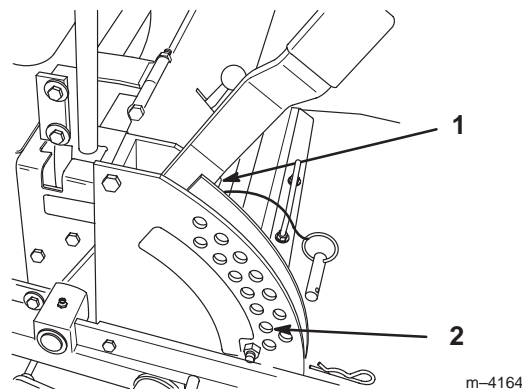

**Figure 46**

1. Transport position
2. 2" (51 mm) height-of-cut

6. Loosen four (4) top chain bolts in slots. Check the length of the rod/swivel assemblies. Distance from outside of rear swivel to outside of front swivel should be 19-7/8" (505 mm) (Fig. 47). Make sure that all four swivels move freely in holes.
7. If measurement is not 19-7/8" (505 mm) on each side, adjust by turning nuts on either side of front swivels.

8. Lift up on four (4) top chain attachment bolts, in the slots, to take slack out of chains and tighten flange lock nuts. (Deck is still supported by two rear and one front blocks under mower.)
9. If bolts contact the end of slots, shorten or lengthen rod/swivel assemblies as required, for extra clearance, adjust each side same amount.

**Note:** When properly adjusted, the front blade tip will be slightly lower than the rear blade tip. See Checking for Bent Blades on page 37 to measure.

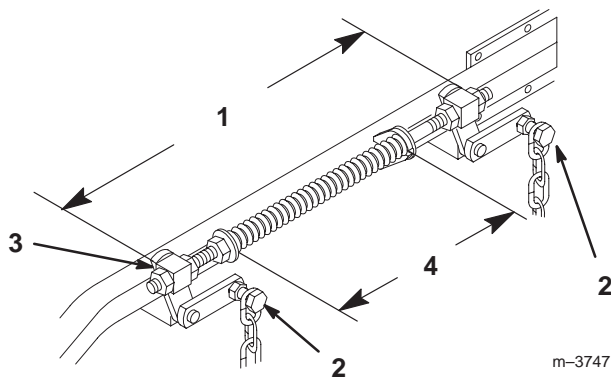

**Figure 47**

- |                                     |                                   |
|-------------------------------------|-----------------------------------|
| 1. 19-7/8" (505 mm) between swivels | 3. Front swivel                   |
| 2. Top chain bolt                   | 4. 11" (279 mm) spring compressed |

10. Recheck that blocks just fit just under the mower and that tension on all four chains is approximately equal. Tighten chain attachment bolts securely.
11. Measure height of cut. This can be checked with the same procedure as Checking for Bent Blades on page 37.
12. Install anti-scalp rollers for proper height-of-cut and tighten securely.

## Compression Spring Adjustment

1. Raise deck lift lever to the transport position, (Fig. 46).
2. Springs are compressed so the distance between the two large washers should be 11" (279 mm) (Fig. 47).
3. Adjust by turning nut in front of each spring (Fig. 47). Clockwise will shorten spring; counter-clockwise will lengthen spring.

## Belt Inspection

Inspect all belts every 100 hours.

1. Check belts for cracks, frayed edges, burn marks or any other damage. Replace damaged belts.

## Clean Under Deck

Remove grass build up under deck daily.

1. Position mower on a flat surface. Stop the engine, set the parking brake, remove the key and disconnect the spark plug wire(s) from the spark plug(s).
2. Raise deck to the transport position.
3. Lift the front of unit and support unit using jack stands.

### CAUTION

#### POTENTIAL HAZARD

- Mechanical or hydraulic jacks may not support machine

#### WHAT CAN HAPPEN

- Weight of machine can cause hydraulic jacks to fail and cause an injury.

#### HOW TO AVOID THE HAZARD

- Use jack stands when supporting machine.
- Do not use hydraulic jacks.

## Replacing the Deck Belt

Squealing when the belt is rotating, blades slipping when cutting grass, frayed belt edges, burn marks and cracks are signs of a worn deck belt. Replace the deck belt if any of these conditions are evident.

1. Stop the engine, set the parking brake, remove the key and disconnect the spark plug wire(s) from the spark plug(s).
2. Remove the PTO drive belt. Refer to Replacing the PTO Drive Belt, on page 57.
3. Loosen two nuts securing idler plate and move the idler arm to relieve belt tension on the idler pulley, then remove the worn deck belt (Fig. 48).
4. Install the new deck belt around the spindle pulleys, belt guide, the idler pulley, and in the lower groove of the center spindle pulley (Fig. 48).
5. Using a socket and torque wrench, rotate the idler adjusting nut until torque is 25–30 ft.-lb. (34–41 N•m). Tighten two nuts.

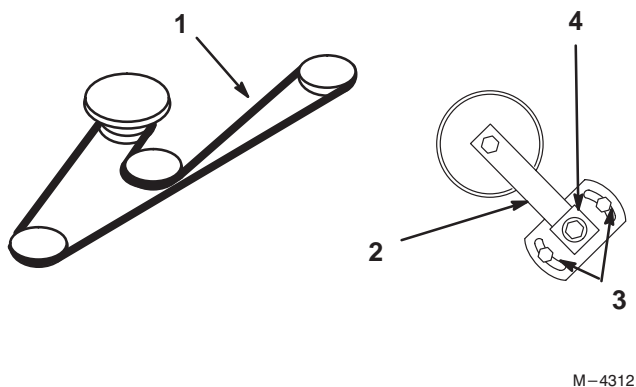

**Figure 48**  
Top View

- |              |                        |
|--------------|------------------------|
| 1. Deck Belt | 3. Idler nuts          |
| 2. Idler Arm | 4. Idler adjusting nut |

6. Reinstall the PTO drive belt. Refer to Replacing the PTO Drive Belt, page 57.

## Replacing the PTO Drive Belt

Squealing when the belt is rotating, blades slipping when cutting grass, frayed belt edges, burn marks and cracks are signs of a worn drive belt. Replace the PTO drive belt if any of these conditions are evident.

1. Stop the engine, set the parking brake, remove the key and disconnect the spark plug wire(s) from the spark plug(s).
2. Remove the clutch retaining strap from machine frame and unplug clutch terminal from wire harness (Fig. 49).
3. Remove PTO drive belt from rear idler arm and front idler pulley assembly. Remove the PTO drive belt (Fig. 49).
4. Place new drive belt over clutch, around rear idler pulley, installed into rear idler arm assembly, installed into front idler pulley assembly and onto top center pulley (Fig. 49).

**IMPORTANT: Check the amount of twist in belt between pulleys. Make sure it is only what is specified in figure 49.**

5. Install clutch retaining strap and plug clutch terminal into main wire harness (Fig. 49).

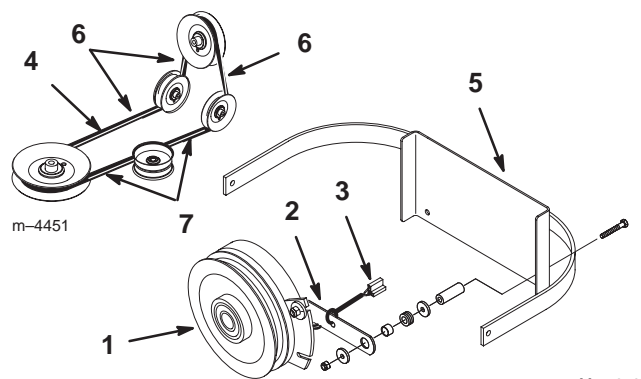
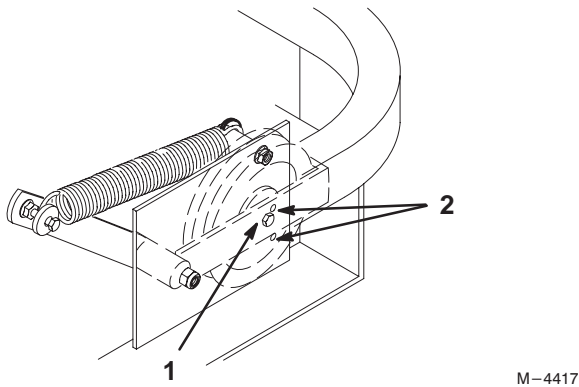

**Figure 49**

- |                           |                    |
|---------------------------|--------------------|
| 1. Clutch                 | 5. Machine Frame   |
| 2. Clutch retaining strap | 6. 1/4" Belt Twist |
| 3. clutch Terminal        | 7. 1/8" Belt Twist |
| 4. PTO belt               |                    |

6. Check belt tension. The center bolt of spring loaded idler must be between the two alignment holes in left support plate (Fig 50).

**Note:** Check position of center bolt in Low Height of Cut. The center bolt must be at or below the top alignment hole. Check position of center bolt in a High Height of Cut. The center bolt must be at or above the lower adjustment hole (Fig 50).



**Figure 50**

1. Center bolt, spring loaded idler
2. Alignment hole

7. If adjustment is required, loosen the fixed idler on right support plate and move up or down in adjustment slot. To relieve belt tension lift up on spring loaded idler.

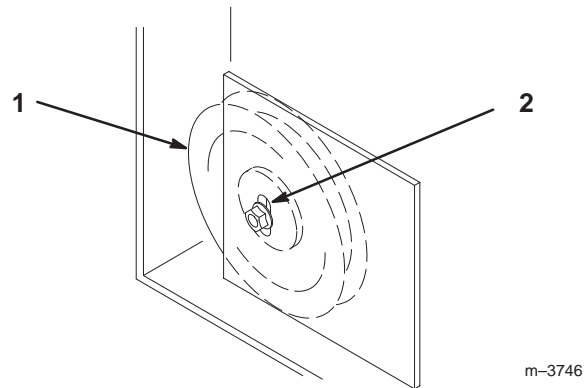

**Figure 51**

1. Fixed Idler
2. Adjustment slot

8. Check belt tension again. The center bolt of spring loaded idler must be between the two alignment holes in left support plate (Fig 50). Adjust, if necessary, and tighten all hardware securely.
9. If the fixed idler contacts the end of the adjustment slot and more belt tension is required, a small change in the lengthen the push arms can be made (Fig. 52).
10. To lengthen, loosen jam nut and rotate ball joint counterclockwise, one turn at a time. Adjust each side the same amount.

**Note:** Increase belt tension by lengthening the push arms and decrease belt tension by shortening push arms.

**IMPORTANT:** If the push arm lengths are changed, then the mower deck must be releveled. See Mower Leveling on page 55.

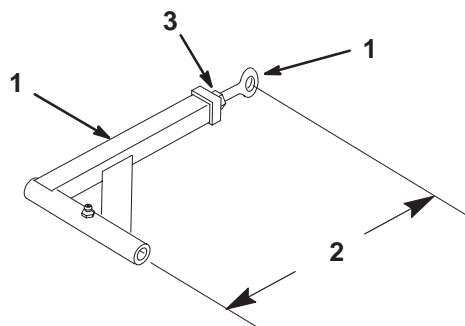

m-3740

**Figure 52**

- |                                 |               |
|---------------------------------|---------------|
| 1. Push arm                     | 3. Jam nut    |
| 2. 15-5/16" (389 mm)<br>nominal | 4. Ball joint |

11. Rotate the belt guide, on rear of the mower, so it is 1/8"-1/4" (3-7 mm) away from the vertical side of the PTO belt (Fig. 53).

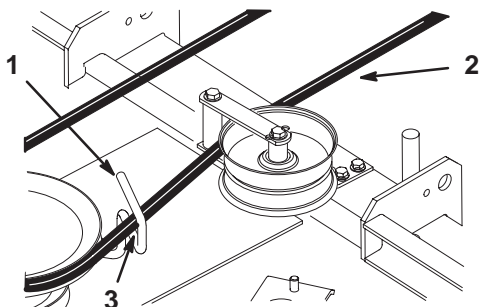

M-4374

**Figure 53**

- |                   |                       |
|-------------------|-----------------------|
| 1. Belt guide     | 3. 1/8"-1/4" (3-7 mm) |
| 2. PTO Drive belt |                       |

## Replacing the Grass Deflector

### WARNING

#### POTENTIAL HAZARD

- An uncovered discharge opening will allow objects to be thrown in operator's or bystander's direction. Also, contact with blade could occur.

#### WHAT CAN HAPPEN

- Thrown objects or blade contact can cause serious injury or kill you or bystanders.

#### HOW TO AVOID THE HAZARD

- Never operate mower unless grass deflector or catcher are installed.

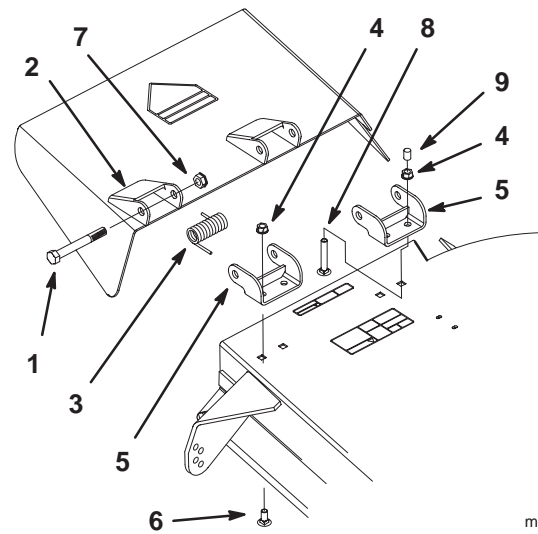

m-4166

Figure 54

1. Remove the locknuts, bolts and springs holding the deflector mounts to the pivot brackets (Fig. 54).
2. If the pivot brackets need to be replaced, remove the carriage bolts, cone locknuts and cap holding the old brackets to the top of the discharge opening, then install the replacement pivot brackets. Make sure the carriage bolt heads are on the inside of the cutting unit (Fig. 54).
3. Install the deflector mounts onto the pivot brackets with the bolts, springs and locknuts. Make sure the straight ends of the springs are positioned between the deflector mounts and the grass deflector (Fig. 54).
4. Tighten the locknuts until they contact the pivot brackets and install cap (Fig. 54).

- |                    |                           |
|--------------------|---------------------------|
| 1. Bolt            | 6. Carriage Bolt (1")     |
| 2. Deflector Mount | 7. Locknut                |
| 3. Spring          | 8. Carriage Bolt (2-1/4") |
| 4. Cone Locknut    | 9. Cap                    |
| 5. Pivot Bracket   |                           |

**IMPORTANT: The grass deflector must be spring-loaded in the down position. Lift the deflector up to test that it snaps to the full down position.**

## Waste Disposal

Engine oil, hydraulic oil and engine coolant are pollutants to the environment. Dispose of these according to your state and local regulations.

## Mercury Tilt Switch

The tilt switch on this unit is located under the seat. Tilt seat up to gain access.

The tilt switch on this unit contains mercury, a hazardous material. Mercury that is outside a sealed container vaporizes at room temperature. The vapors are harmful. Mercury can be absorbed through the skin. Do not attempt to open or repair this switch.

A very small amount of mercury is contained in a hermetically sealed body. The steel switch is then potted in a hard epoxy in a plastic case. It is unlikely that the mercury will ever escape from the enclosure. These high performance and reliable inexpensive switches are recyclable.

Mercury is an important and beneficial compound but requires special care in handling and disposal. When used and managed properly, mercury is not a threat to people or the environment. This information is presented to users so that they are aware that these switches contain mercury and will apply sound disposal practices when these devices reach their normal end of life or are damaged.

## Mercury Tilt Switch Disposal

Several states have passed laws concerning the disposal of devices containing mercury. In all the remaining states it is advisable to follow similar procedures. The laws state that these sealed devices contain mercury and should not be placed in the garbage until the mercury is removed and reused, recycled or otherwise managed to insure that it does not become part of solid waste or waters. Management and disposal practices must be within relevant federal, state or local laws.

Return the switch to your Toro dealer if it is faulty and is being replaced or if the unit containing the switch is no longer operating and is being scrapped. If the switch is damaged or broken open use extreme caution in handling. Call your local waste management authority or Toro Customer Service for instructions.

### CAUTION

#### POTENTIAL HAZARD

- **The mercury contained in the tilt switch is poisonous.**

#### WHAT CAN HAPPEN

- **Exposure to mercury can cause severe illness.**

#### HOW TO AVOID THE HAZARD

- **Never attempt to open or repair the tilt switch.**
- **Avoid contact with the mercury.**

# Wiring Diagram

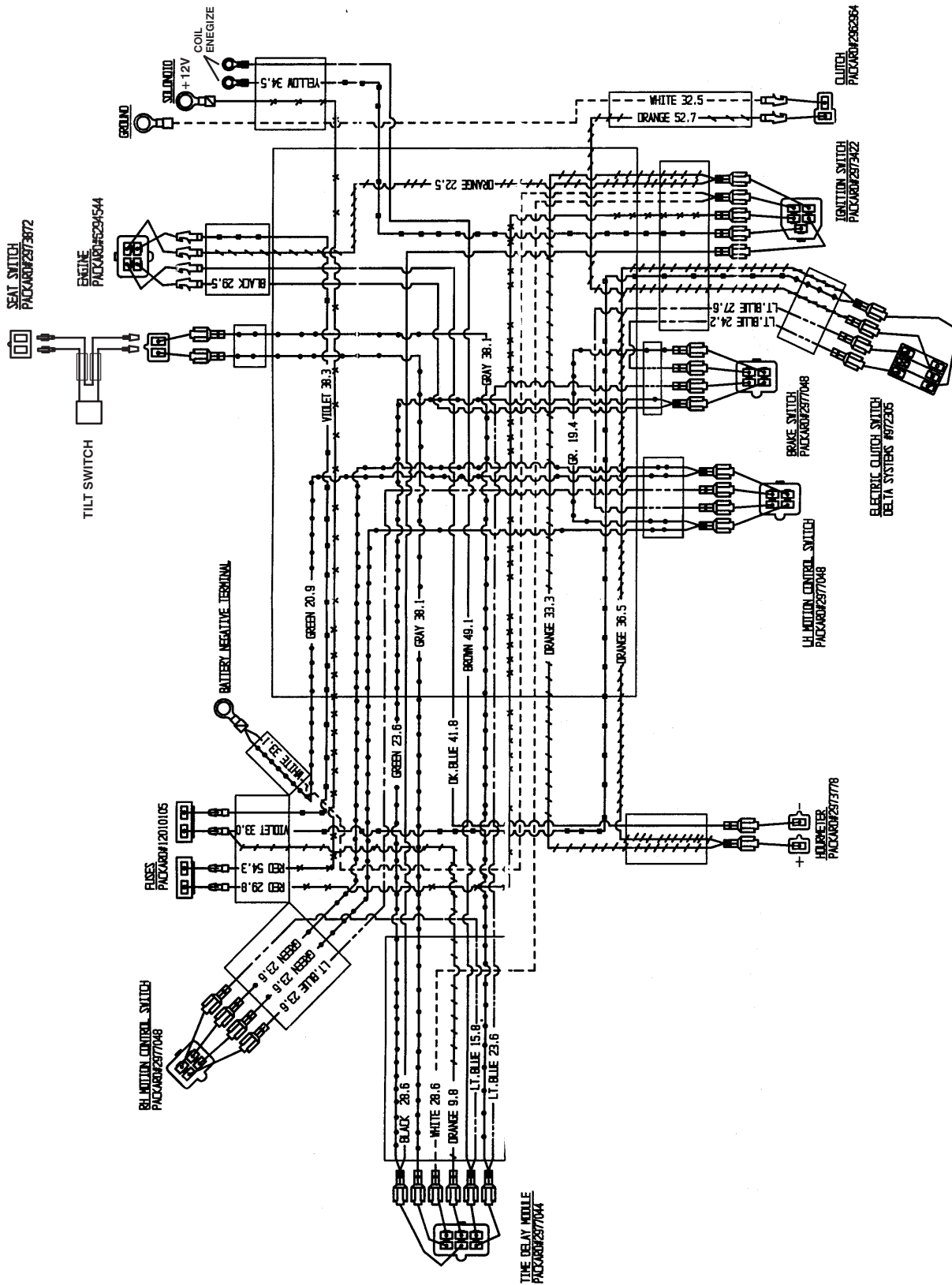

## Cleaning and Storage

1. Disengage the power take off (PTO), set the parking brake and turn the ignition key to “OFF” to stop the engine. Remove spark plug wire. Remove the key.
2. Remove grass clippings, dirt, and grime from the external parts of the entire machine, especially the engine and hydraulic system. Clean dirt and chaff from the outside of the engine’s cylinder head fins and blower housing.

**IMPORTANT: You can wash the machine with mild detergent and water. Do not pressure wash the machine. Avoid excessive use of water, especially near the control panel, engine, hydraulic pumps and motors.**

3. Service the air cleaner; refer to Air Cleaner, page 39.
4. Grease and oil the machine; refer to Greasing and Lubrication, page 45.
5. Change the crankcase oil; refer to Engine Oil, page 41.
6. Change the hydraulic fluid; refer to Hydraulic System, page 48.
7. Check the tire pressure; refer to Tire Pressure, page 47.
8. Charge the battery; refer to Battery page 54.
9. Scrape any heavy buildup of grass and dirt from the underside of the mower, then wash the mower with a garden hose.
10. Check the condition of the blades. Refer to Cutting Blades on page 36.
11. Prepare the machine for storage when non-use occurs over 30 days. Prepare machine for storage as follows.
  - A. Add a petroleum based stabilizer/conditioner to fuel in the tank. Follow mixing instructions from stabilizer

manufacture. (1 oz. per gallon). **Do not use an alcohol based stabilizer (ethanol or methanol).**

- Note:** A fuel stabilizer/conditioner is most effective when mixed with fresh gasoline and used at all times.
- B. Run engine to distribute conditioned fuel through the fuel system (5 minutes).
  - C. Stop engine, allow to cool and drain the fuel tank; refer to Fuel Tank, page 44.
  - D. Restart engine and run it until it stops.
  - E. Choke or prime the engine. Start and run engine until it will not start. Operate primer, if equipped on machine, several times to ensure no fuel remains in primer system.
  - F. Dispose of fuel properly. Recycle as per local codes.

**IMPORTANT: Do not store stabilizer/conditioned gasoline over 90 days.**

12. Remove the spark plug(s) and check its condition; refer to Spark Plug, page NO TAG. With the spark plug(s) removed from the engine, pour two tablespoons of engine oil into the spark plug hole. Now use the starter to crank the engine and distribute the oil inside the cylinder. Install the spark plug(s). Do not install the wire on the spark plug(s).
13. Check and tighten all bolts, nuts, and screws. Repair or replace any part that is damaged or defective.
14. Paint all scratched or bare metal surfaces. Paint is available from your Authorized Service Dealer.
15. Store the machine in a clean, dry garage or storage area. Remove the key from the ignition switch and keep it in a memorable place out of reach of children or other unauthorized users. Cover the machine to protect it and keep it clean.

# Troubleshooting

PROBLEM	POSSIBLE CAUSES	CORRECTIVE ACTION
Starter does not crank	<ol style="list-style-type: none"> <li>1. Blade control (PTO) is ENGAGED.</li> <li>2. Parking brake is not on.</li> <li>3. Operator is not seated.</li> <li>4. Battery is dead.</li> <li>5. Electrical connections are corroded or loose.</li> <li>6. Fuse is blown.</li> <li>7. Relay or switch is defective.</li> </ol>	<ol style="list-style-type: none"> <li>1. Move blade control (PTO) to DISENGAGED.</li> <li>2. Set parking brake.</li> <li>3. Sit on the seat.</li> <li>4. Charge the battery.</li> <li>5. Check electrical connections for good contact.</li> <li>6. Replace fuse.</li> <li>7. Contact Authorized Service Dealer.</li> </ol>
Engine will not start, starts hard, or fails to keep running.	<ol style="list-style-type: none"> <li>1. Fuel tank is empty.</li> <li>2. Choke is not ON.</li> <li>3. Air cleaner is dirty.</li> <li>4. Spark plug wires is loose or disconnected.</li> <li>5. Spark plugs are pitted, fouled, or gap is incorrect.</li> <li>6. Dirt in fuel filter.</li> <li>7. Dirt, water, or stale fuel is in fuel system.</li> </ol>	<ol style="list-style-type: none"> <li>1. Fill fuel tank with gasoline.</li> <li>2. Move choke lever to ON.</li> <li>3. Clean or replace air cleaner element.</li> <li>4. Install wires on spark plug.</li> <li>5. Install new, correctly gapped spark plugs.</li> <li>6. Replace fuel filter.</li> <li>7. Contact Authorized Service Dealer.</li> </ol>
Engine loses power.	<ol style="list-style-type: none"> <li>1. Engine load is excessive.</li> <li>2. Air cleaner is dirty.</li> <li>3. Oil level in crankcase is low.</li> <li>4. Cooling fins and air passages under engine blower housing are plugged.</li> <li>5. Spark plugs are pitted, fouled, or gap is incorrect.</li> <li>6. Vent in fuel cap is closed.</li> <li>7. Dirt in fuel filter.</li> <li>8. Dirt, water, or stale fuel is in fuel system.</li> </ol>	<ol style="list-style-type: none"> <li>1. Reduce ground speed.</li> <li>2. Clean air cleaner element.</li> <li>3. Add oil to crankcase.</li> <li>4. Remove obstruction from cooling fins and air passages.</li> <li>5. Install new, correctly gapped spark plugs.</li> <li>6. Open vent in fuel cap.</li> <li>7. Replace fuel filter.</li> <li>8. Contact Authorized Service Dealer.</li> </ol>

PROBLEM	POSSIBLE CAUSES	CORRECTIVE ACTION
Engine overheats.	<ol style="list-style-type: none"> <li>1. Engine load is excessive.</li> <li>2. Oil level in crankcase is low.</li> <li>3. Cooling fins and air passages under engine blower housing are plugged.</li> </ol>	<ol style="list-style-type: none"> <li>1. Reduce ground speed.</li> <li>2. Add oil to crankcase.</li> <li>3. Remove obstruction from cooling fins and air passages.</li> </ol>
Machine does not drive.	<ol style="list-style-type: none"> <li>1. Traction belt is worn, loose or broken.</li> <li>2. Traction belt is off pulley.</li> <li>3. Hydro fluid level low.</li> </ol>	<ol style="list-style-type: none"> <li>1. Contact Authorized Service Dealer.</li> <li>2. Contact Authorized Service Dealer.</li> <li>3. Add hydro fluid to reservoir.</li> </ol>
Abnormal vibration.	<ol style="list-style-type: none"> <li>1. Cutting blade(s) is/are bent or unbalanced.</li> <li>2. Blade mounting bolt is loose.</li> <li>3. Engine mounting bolts are loose.</li> <li>4. Loose engine pulley, idler pulley, or blade pulley.</li> <li>5. Engine pulley is damaged.</li> <li>6. Blade spindle bent.</li> </ol>	<ol style="list-style-type: none"> <li>1. Install new cutting blade(s).</li> <li>2. Tighten blade mounting bolt.</li> <li>3. Tighten engine mounting bolts.</li> <li>4. Tighten the appropriate pulley.</li> <li>5. Contact Authorized Service Dealer.</li> <li>6. Contact Authorized Service Dealer.</li> </ol>
Uneven cutting height.	<ol style="list-style-type: none"> <li>1. Blade(s) not sharp.</li> <li>2. Cutting blade(s) is/are bent.</li> <li>3. Mower is not level.</li> <li>4. Gage wheel not set correctly.</li> <li>5. Underside of mower is dirty.</li> <li>6. Tire pressure is incorrect.</li> <li>7. Blade spindle bent.</li> </ol>	<ol style="list-style-type: none"> <li>1. Sharpen blade(s).</li> <li>2. Install new cutting blade(s).</li> <li>3. Level mower from side-to-side and front-to-rear.</li> <li>4. Adjust gage wheel height.</li> <li>5. Clean the underside of the mower.</li> <li>6. Adjust tire pressure.</li> <li>7. Contact Authorized Service Dealer.</li> </ol>

<b>PROBLEM</b>	<b>POSSIBLE CAUSES</b>	<b>CORRECTIVE ACTION</b>
Blades do not rotate.	<ol style="list-style-type: none"><li>1. Drive belt is worn, loose or broken.</li><li>2. Drive belt is off pulley.</li><li>3. Deck belt is worn, loose or broken.</li><li>4. Deck belt is off pulley.</li></ol>	<ol style="list-style-type: none"><li>1. Install new drive belt.</li><li>2. Install drive belt and check adjusting shafts and belt guides for correct position.</li><li>3. Install new deck belt.</li><li>4. Install deck pulley and check the idler pulley, idler arm and spring for correct position and function.</li></ol>









# THE TORO TOTAL COVERAGE GUARANTEE

## A One-Year Limited Warranty (A Two-Year Full Warranty for Residential Use)

### What Is Covered By This Express Warranty?

The Toro Company promises to repair any TORO Product used for commercial, institutional, or rental purposes if defective in materials or workmanship. The following time frames apply from the date of purchase:

<u>Product</u>	<u>Warranty Period</u>
All Products . . . . .	1 year
All Spindles . . . . .	2 years parts & labor, 3rd year parts only

Engines on the following: . . . . . 2 years

- Out Front and MidMount Zero Radius Tractors
- ProLine Mid-size Mowers
- Groundsmaster Riding Mowers
- ProLine Hand Held Gas Products (AE & LE engines only)
- Backpack Blowers

The cost of parts and labor are included, but the customer pays the transportation cost. Transportation within a 15-mile radius of a TORO ProLine Service Dealer is covered under this warranty for Riding Products, Midsized Mowers and Turf Maintenance Equipment.

### What Products Are Covered By This Warranty?

- Z-Master Zero Radius Tractors
- ProLine Mid-size Mowers
- Groundsmaster Riding Mowers
- ProLine Hand-held Gas Products
- Backpack Blowers
- Turf Maintenance Equipment
- Debris Management Equipment

### How About Residential Use?

TORO Products used for residential use are covered by a full two-year warranty.

### How Do You Get Warranty Service?

Should you feel your TORO Product contains a defect in materials or workmanship, contact the dealer who sold you the product or any TORO ProLine Service Dealer. The Yellow Pages of your telephone directory is a good reference source; look under TORO Commercial Service Dealers. The Service Dealer will either arrange service at his/her dealership or recommend another authorized Service Dealer who may be more convenient. You may need proof of purchase (copy of registration card, sales receipt, etc.) for warranty validation.

If for any reason you are dissatisfied with a Service Dealer's analysis of the defect in materials or workmanship or if you need a referral to a TORO ProLine Service Dealer, please feel free to contact us at the following address:

Toro Customer Service Department  
8111 Lyndale Avenue South  
Bloomington, MN 55420-1196  
612-888-8801 or 800-348-2424

### What Must You Do To Keep The Warranty In Effect?

You must maintain your TORO Product by following the maintenance procedures described in the operator's manual. Such routine maintenance, whether performed by a dealer or by you, is at your expense.

### What Does This Warranty Not Cover? and How Does Your State Law Relate To This Warranty?

There is no other express warranty except for special emission system coverage on some products and as described above. This express warranty does not cover:

- Cost of regular maintenance service or parts, such as filters, fuel, lubricants, tune-up parts, blade sharpening, brake and clutch adjustments.
- Any product or part which has been altered or misused or required replacement or repair due to normal wear, accidents, or lack of proper maintenance.
- Repairs necessary due to improper fuel, contaminants in the fuel system, or failure to properly prepare the fuel system prior to any period of non-use over three months.
- Pickup and delivery charges for distances beyond a 15-mile radius from a TORO ProLine Service Dealer.

All repairs covered by this warranty must be performed by a TORO Service Dealer using Toro approved replacement parts.

**The Toro Company is not liable for indirect or consequential damages in connection with the use of the TORO Products covered by this warranty, including any cost or expense of providing substitute equipment or service during reasonable periods of malfunction or non-use pending completion of repairs under this warranty. Some states do not allow exclusions of incidental or consequential damages, so the above exclusion may not apply to you.**

**This warranty gives you specific legal rights, and you may also have other rights which vary from state to state.**

### COUNTRIES OTHER THAN THE UNITED STATES OR CANADA

Customers who have purchased TORO products exported from the United States or Canada should contact their TORO Distributor (Dealer) to obtain guarantee policies for your country, province, or state. If for any reason you are dissatisfied with your Distributor's service or have difficulty obtaining guarantee information, contact the TORO importer. If all other remedies fail, you may contact us at The Toro Company.