



## 518xi, 520xi & 522xi Tractor

Model Numbers 73471, 73542,  
and 73561—200000001 & Up

Setup  
Instructions

### Loose Parts

**Note:** Use the chart below to identify parts for assembly.

DESCRIPTION	QTY.	USE
Seat Assembly	1	Installing the seat
Shoulder Bolt – 5/16"	2	
Locknut – 5/16"	2	
Steering Wheel	1	Installing the steering wheel
Boot Washer	1	
Nut	1	
Lock Washer	1	
Trim Cover	1	
Bolt – 1/4"-20 x .88" Long	2	Attaching the battery cables
Washer – 1/4"	2	
Hex Nut – 1/4"-20	2	
Hitch Pin	1	Installing the drawbar hitch pin
Hairpin Cotter	1	
Flat Washer – .50" I.D.	1	
Key	2	Use in ignition and "Key Choice" switches
Operator's Manual	1	Read before operating the tractor
Engine Operator's Manual	1	Read before operating the tractor
Riding Mower Safety Video	1	Watch before operating the tractor

### Installing the Seat

- Mount the seat to the seat base using two 5/16" shoulder bolts and lock nuts (Fig. 1).
- Insert the seat switch wire through the center opening in the seat base (Fig 1).
- Push the seat switch wire connector into the wire harness connector.

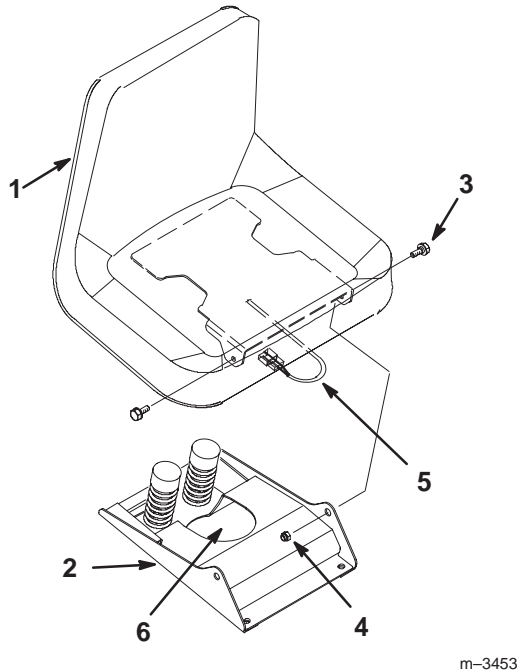

Figure 1

- |                            |                                 |
|----------------------------|---------------------------------|
| 1. Seat                    | 5. Seat switch wire connector   |
| 2. Seat base               | 6. Opening for seat switch wire |
| 3. 5/16" shoulder bolt (2) |                                 |
| 4. 5/16" Locknut (4)       |                                 |

m-3453

4. Secure the steering wheel to the shaft with a lock washer and nut (Fig. 2). Tighten the retaining nut to 45–50 ft–lbs.
5. Install the trim cover on the steering wheel.

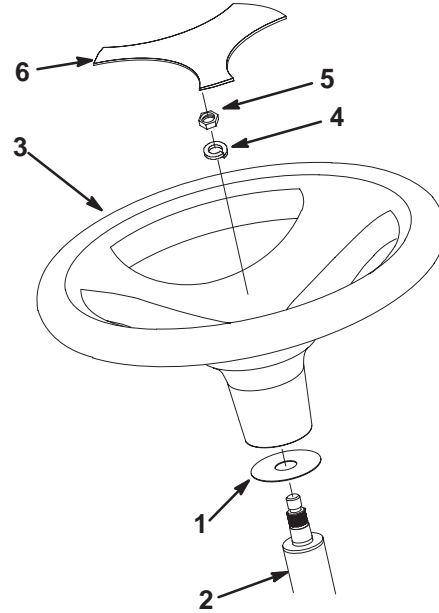

Figure 2

- |                   |                |
|-------------------|----------------|
| 1. Boot washer    | 4. Lock washer |
| 2. Steering shaft | 5. Nut         |
| 3. Steering wheel | 6. Trim cover  |

m-2482

---

## Installing the Steering Wheel

1. Install the boot washer onto the steering shaft (Fig. 2).
2. Remove the plastic trim cover from the steering wheel (Fig. 2)
3. Install the steering wheel onto the shaft, carefully aligning the splines (Fig. 2).

**Note:** On manual steering models, be sure to align steering wheel in the straight ahead position. There is no fixed straight ahead position on power steering models.

---

## Checking Front Wheel Toe-In

With the tractor on a level surface, check to make sure the front wheel toe-in is between 1/8" and 1/4". For instructions on adjusting toe-in, refer to the Maintenance section in Operator's Manual.

## Check to Insure that Steering Linkage is Centered

1. With the tractor on a level surface, turn the steering wheel fully to the left and check the clearance of the left hand spindle stop to the stop on the front axle. There should be a slight clearance between the stops (Fig. 3).

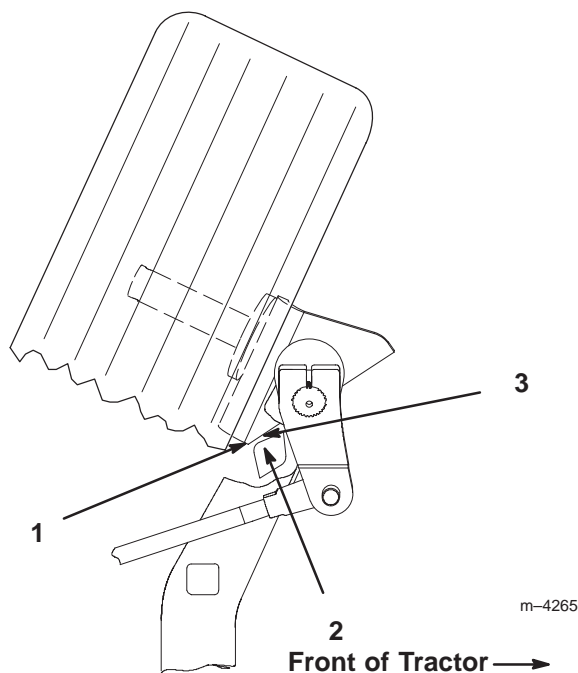

Figure 3

- |                           |              |
|---------------------------|--------------|
| 1. Left hand spindle stop | 3. Clearance |
| 2. Axle stop              |              |

2. Repeat for the right front tire in a right turn.
3. If the stops on one side hit, and on the other side have clearance, shorten the tie rod on the side that hits, and equally lengthen the tie rod on the opposite side until both sides have clearance. Recheck the toe in.

## Checking Tire Pressure

Check front and rear tire pressure. The correct front and rear tire pressure is 20 psi (138 kPa).

## Activating the Battery

### **! DANGER**

#### POTENTIAL HAZARD

- Battery electrolyte contains sulfuric acid which is a deadly poison and it causes severe burns.

#### WHAT CAN HAPPEN

- If you carelessly drink electrolyte you could die or if it gets onto your skin you will be burned.

#### HOW TO AVOID THE HAZARD

- Do not drink electrolyte and avoid contact with skin, eyes or clothing. Wear safety glasses to shield your eyes and rubber gloves to protect your hands.
- Fill the battery where clean water is always available for flushing the skin.
- Follow all instructions and comply with all safety messages on the electrolyte container.

1. Remove the battery from the tractor (refer to Removing the Battery in your tractor Operator's Manual).

**Note:** Never fill the battery electrolyte with the battery installed in the tractor.

2. Remove the filler caps from the battery. Slowly pour electrolyte into each cell until the electrolyte level is up to the lower part of the tube (Fig. 4). Use an electrolyte with a specific gravity of 1.265.

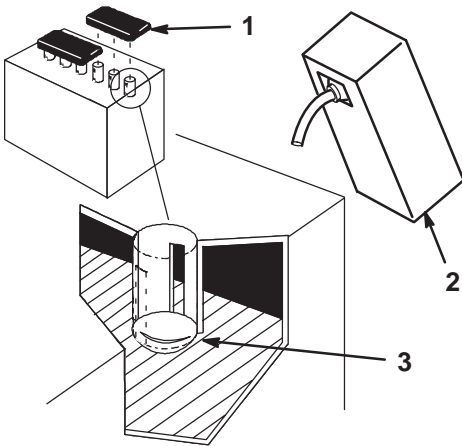

Figure 4

1. Filler caps
2. Electrolyte
3. Lower part of tube

1262

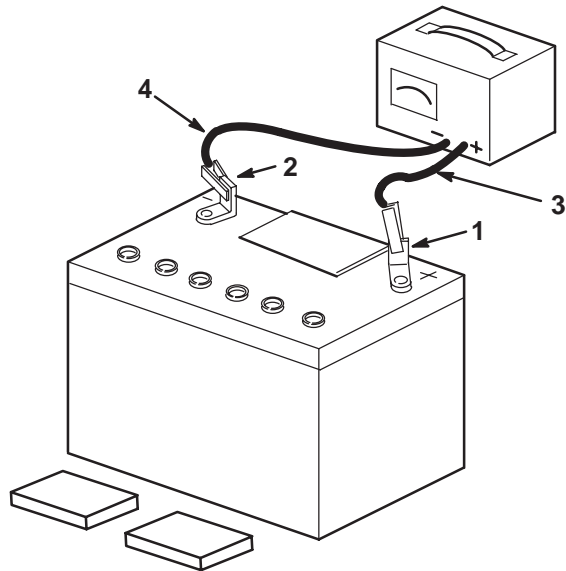

Figure 5

1. Positive battery post
2. Negative battery post
3. Red (+) charger lead
4. Black (-) charger lead

1254

**! WARNING**

**POTENTIAL HAZARD**

- Charging battery produces gasses.

**WHAT CAN HAPPEN**

- Battery gasses can explode.

**HOW TO AVOID THE HAZARD**

- Keep cigarettes, sparks and flames away from battery.

3. Leave the filler caps off and connect a 3–4 amp battery charger to the battery posts (Fig. 5). Charge the battery at a rate of 4 amperes or less for 4 hours (12 volts).
4. When the battery is fully charged, unplug the charger from electrical outlet, then disconnect the charger leads from the battery posts (Fig. 5).

5. Slowly pour electrolyte into each cell until the level is once again up to “UPPER” line on the battery case (Fig. 4), then install the filler caps.
6. Install the battery in the tractor and connect the battery cables (refer to Installing the Battery in your tractor Operator’s Manual).

**Note:** Do not run the tractor with the battery disconnected.

## Installing the Drawbar Hitch Pin

Insert the drawbar hitch pin into the drawbar hitch and secure it with a .50” I.D. flat washer and hairpin cotter (Fig. 6).

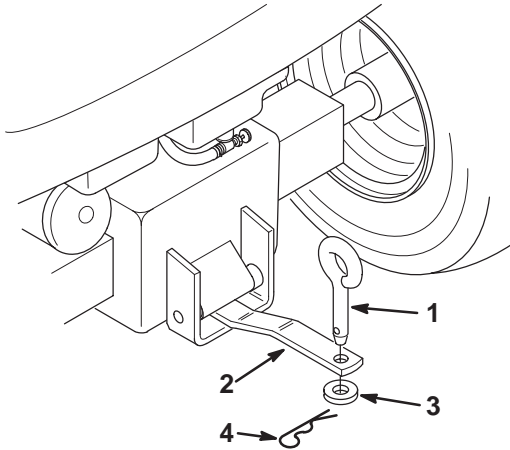

m-2481

Figure 6

- |                      |                     |
|----------------------|---------------------|
| 1. Drawbar hitch pin | 3. .50" Flat washer |
| 2. Drawbar hitch     | 4. Hairpin cotter   |

## Checking the Wiring and Fasteners

- Inspect the tractor for any loose electrical connections and secure them as required. Check the wire routing to make sure moving parts do not interfere with wires and cause a short.
- Assure all fasteners are tight.

## Burnishing the Clutch

The following break-in procedure must be performed as part of pre-delivery service or when a new clutch is installed.

**Note:** There must be a PTO driven attachment installed to provide a load in order to burnish the clutch facings properly.

- Run the engine at full throttle and engage the clutch bringing the load to full speed. Then disengage the clutch.
- Let the load come to a full stop, then engage again.
- Repeat these procedures (1 and 2) 5 times.

## Test Driving the Tractor

- Check the oil level in the crankcase (refer to Engine Oil in your tractor Operator's Manual for oil type, viscosity and crankcase capacity).

**Note:** When checking the oil level, slide the dipstick all the way into the filler tube, but do not screw the dipstick onto the filler tube.

- Check the oil level in the transaxle (refer to Transaxle Fluid in your tractor Operator's Manual for oil type, viscosity and capacity).
- Check to make sure all lubrication points have been greased as shown in the Maintenance section of tractor Operator's Manual.
- Fill the tank with unleaded regular gasoline with an octane rating of at least 85. Open the fuel shutoff valve and check the fuel hose and fittings for leaks.

5. As applicable, check and test the operation of the following:
  - Engine, choke and throttle controls
  - Gauges
  - Headlights and taillights
  - Indicator lights
  - PTO clutch and brake
  - Lift system
  - Service and parking brakes
  - Transmission controls
  - Steering
  - Tractor operation in forward and reverse
6. Test the operation of the safety interlock system (refer to the tractor Operator's Manual for the correct procedure).



