



**Wheel Horse®**  
**520Lxi Tractor**

Model No. 73547—200000001 & Up

**Operator's Manual**

# Introduction

Thank you for purchasing a Toro product.

All of us at Toro want you to be completely satisfied with your new product, so feel free to contact your local Authorized Service Dealer for help with service, genuine replacement parts, or other information you may require.

Whenever you contact your Authorized Service Dealer or the factory, always know the model and serial numbers of your product. These numbers will help the Service Dealer or Service Representative provide exact information about your specific product. You will find the model and serial number plate located in a unique place on the product as shown below.

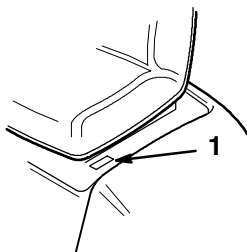

m-2345

1. Model and Serial Number Plate

For your convenience, write the product model and serial numbers in the space below.

<b>Model No.</b> _____
<b>Serial No.</b> _____

Read this manual carefully to learn how to operate and maintain your product correctly. Reading this manual will help you and others avoid personal injury and damage to the product. Although we design, produce and market safe, state-of-the-art products, you are responsible for using the product properly and safely. You are also responsible for training persons, you allow to use the product, about safe operation.

The warning system in this manual identifies potential hazards and has special safety messages that help you and others avoid personal injury, even death. DANGER, WARNING and CAUTION are signal words used to identify the level of hazard. However, regardless of the hazard, be extremely careful.



**DANGER** signals an extreme hazard that will cause serious injury or death if the recommended precautions are not followed.

**WARNING** signals a hazard that may cause serious injury or death if the recommended precautions are not followed.

**CAUTION** signals a hazard that may cause minor or moderate injury if the recommended precautions are not followed.

Two other words are also used to highlight information. “Important” calls attention to special mechanical information and “Note” emphasizes general information worthy of special attention.

The left and right side of the machine is determined by sitting on the seat in the normal operator’s position.

	<b>WARNING:</b>	
<b>The engine exhaust from this product contains chemicals known to the State of California to cause cancer, birth defects, or other reproductive harm.</b>		

**IMPORTANT:** The engine in this product is not equipped with a spark arrester muffler. It is a violation of California Public Resource Code Section 4442 to use or operate this engine on any forest-covered, brush-covered or grass-covered land as defined in CPRC 4126. Other states or federal areas may have similar laws.

# Contents

	Page		Page
Safety .....	2	Positioning the Seat .....	22
Safe Operating Practices .....	2	Headlights and Taillights .....	22
Toro Riding Mower Safety .....	4	Positioning the Tilt Steering Wheel .....	22
Slope Chart .....	5	Using the Cruise Control .....	23
Safety and Instruction Decals .....	7	The Smart Turnt Steering Feature .....	23
Check Before Operating .....	8	Pushing the Machine by Hand .....	24
Opening the Hood .....	8	Maintenance .....	25
Closing the Hood .....	9	Service Interval Chart .....	25
Removing the Side Panels .....	9	Air Cleaner .....	26
Adding Fuel .....	10	Engine Oil .....	28
Check the Engine Oil Level .....	11	Changing the Engine Oil Filter .....	29
Check the Cooling System .....	11	Changing the Engine Coolant .....	30
Check for Debris .....	12	Spark Plugs .....	30
Check the Safety Interlock System .....	13	Greasing and Lubrication .....	32
Check the Brake .....	13	Tire Pressure .....	33
Operation .....	14	Brake .....	34
Think Safety First .....	14	Fuel Tank .....	35
Controls .....	14	Fuel Filter .....	36
Parking Brake .....	14	Front Wheel Toe-In .....	36
Starting and Stopping the Engine .....	14	Transaxle Fluid .....	38
Operating the Power Take Off (PTO) .....	15	Fuse .....	40
The Safety Interlock System .....	16	Headlights .....	40
Gauges and Indicator Lights .....	18	Taillights .....	41
Driving Forward or Backward .....	19	Battery .....	42
Stopping the Machine .....	20	Cleaning and Storage .....	44
Re-centering the Steering Wheel .....	21	Wiring Diagram .....	46
Attachment Power Lift .....	21	Wiring Diagram .....	47
		Troubleshooting .....	48
		The Toro Total Coverage Guarantee .....	54

**The enclosed Engine Owner's Manual is supplied for information regarding The U.S. Environmental Protection Agency (EPA) and the California Emission Control Regulation of emission systems, maintenance and warranty.**

**Keep this engine Owner's Manual with your unit. Should this engine Owner's Manual become damaged or illegible, replace immediately. Replacements may be ordered through the engine manufacturer.**

# Safety

**This machine meets or exceeds the B71.1-1998 specifications of the American National Standards Institute, in effect at the time of production. However, improper use or maintenance by the operator or owner can result in injury. To reduce the potential for injury, comply with these safety instructions and always pay attention to the safety alert ▲ symbol, which means CAUTION, WARNING, or DANGER—“personal safety instruction.” Failure to comply with the instruction may result in personal injury or death.**

## Safe Operating Practices

The following instructions are from ANSI standard B71.1—1998.

This product is capable of amputating hands and feet and throwing objects. Always follow all safety instructions to avoid serious injury or death.

### General Operation

- Read, understand, and follow all instructions in the operator’s manual and on the machine before starting.
- Allow only responsible adults who are familiar with the instructions to operate the machine.
- Clear the area of objects such as rocks, toys, wire, etc., which could be picked up and thrown by the blade.
- Be sure the area is clear of other people before mowing. Stop the machine if anyone enters the area.
- Never carry passengers.
- Do not mow in reverse unless absolutely necessary. Always look down and behind before and while backing.

- Be aware of the mower discharge direction and do not point it at anyone. Do not operate the mower without either the entire grass catcher or the guard in place.
- Slow down before turning.
- Never leave a running machine unattended. Always turn off blades, set parking brake, stop engine, and remove keys before dismounting.
- Turn off blades when not mowing.
- Stop the engine before removing the grass catcher or unclogging the chute.
- Mow only in daylight or good artificial light.
- Do not operate the machine while under the influence of alcohol or drugs.
- Watch for traffic when operating near or crossing roadways.
- Use extra care when loading or unloading the machine into a trailer or truck.
- Always wear safety goggles or safety glasses with side shields when operating mower.
- Data indicates that operators, age 60 years and above, are involved in a large percentage of riding mower-related injuries. These operators should evaluate their ability to operate the riding mower safely enough to protect themselves and others from serious injury.

### Slope Operation

Slopes are a major factor related to loss-of-control and tip-over accidents, which can result in severe injury or death. All slopes require extra caution. If you cannot back up the slope or if you feel uneasy on it, do not mow it.

- Mow up and down slopes, not across.
- Remove obstacles such as rocks, tree limbs, etc.
- Watch for holes, ruts or bumps. Uneven terrain could overturn the machine. Tall grass can hide obstacles.
- Use slow speed. Choose a low gear so that you will not have to stop or shift while on the slope.
- Follow Toro's recommendations for wheel weight or counterweights to improve stability.
- Use extra care with grass catchers or other attachments. These can change the stability of the machine.
- Keep all movement on slopes slow and gradual. Do not make sudden changes in speed or direction.
- Avoid starting or stopping on a slope. If tires lose traction, disengage the blades and proceed slowly straight down the slope.
- Do not turn on slopes unless necessary, and then, turn slowly and gradually downhill, if possible.
- Do not mow near drop-offs, ditches, or embankments. The machine could suddenly turn over if a wheel goes over the edge of a cliff or ditch, or if an edge caves in.
- Do not mow on wet grass. Reduced traction could cause sliding.
- Do not try to stabilize the machine by putting your foot on the ground.
- Do not use a grass catcher on steep slopes.

## Children

Tragic accidents can occur if the operator is not alert to the presence of children. Children are often attracted to the machine and the mowing activity. Never assume that children will remain where you last saw them.

- Keep children out of the mowing area and under the watchful care of another responsible adult.
- Be alert and turn the machine off if children enter the area.
- Before and while backing, look behind and down for small children.
- Never carry children, even with the blades off. They may fall off and be seriously injured or interfere with safe machine operation.
- Never allow children to operate the machine.
- Use extra care when approaching blind corners, shrubs, trees, the end of a fence or other objects that may obscure vision.

## Service

- Use extra care when handling gasoline and other fuels. They are flammable and vapors are explosive.
  - A. Use only an approved container.
  - B. Never remove the gas cap or add fuel when the engine is running. Allow the engine to cool before refueling. Do not smoke.
  - C. Never refuel the machine indoors.
  - D. Never store the machine or fuel container inside where there is an open flame, such as near a water heater or furnace.
- Never run a machine inside a closed area.
- Keep nuts and bolts tight, especially the blade attachment bolts. Keep equipment in good condition.
- Never tamper with safety devices. Check their proper operation regularly.
- Keep the machine free of grass, leaves, or other debris build-up. Clean up oil or fuel spillage. Allow the machine to cool before storing.
- Stop and inspect the equipment if you strike an object. Repair, if necessary, before restarting.

- Grass catcher components are subject to wear, damage and deterioration, which could expose moving parts or allow objects to be thrown. Frequently check components and replace with manufacturer's recommended parts, when necessary.
- Mower blades are sharp and can cut. Wrap the blade(s) or wear gloves, and use extra caution when servicing them.
- Use only genuine Toro replacement parts to ensure that original standards are maintained.

## Toro Riding Mower Safety

The following list contains safety information specific to Toro products or other safety information that you must know that is not included in the ANSI standard.

 **WARNING**

**POTENTIAL HAZARD**

- **Engine exhaust contains carbon monoxide, which is an odorless, deadly poison.**

**WHAT CAN HAPPEN**

- **Carbon monoxide can kill you and is also known to the State of California to cause birth defects.**

**HOW TO AVOID THE HAZARD**

- **Do not run engine indoors or in an enclosed area.**

- Stop the engine, disconnect spark plug wire(s) and remove key before performing any service, repairs, maintenance or adjustments.
- Slow down before turning. Sharp turns on any terrain may cause loss of control.
- Never leave a running machine unattended. Always turn off blades, set parking brake, stop engine, and remove the ignition and "Key Choice" keys before dismounting.

- Keep hands, feet, hair and loose clothing away from attachment discharge area, underside of mower and any moving parts while engine is running.
- Do not touch equipment or attachment parts which may be hot from operation. Allow to cool before attempting to maintain, adjust or service.
- Remove obstacles such as rocks, tree limbs, etc. from the mowing area. Watch for holes, ruts or bumps, as uneven terrain could overturn the machine. Tall grass can hide obstacles.
- Battery acid is poisonous and can cause burns. Avoid contact with skin, eyes and clothing. Protect your face, eyes and clothing when working with a battery.
- Battery gases can explode. Keep cigarettes, sparks and flames away from battery.
- Use only genuine replacement parts to ensure that original standards are maintained.
- Mow up and down slopes greater than 5°, not across.
- Mow downhill only on slopes above 10°, never mow uphill. If a steep slope must be ascended, back up the hill, and drive forward down the hill, keeping the machine in gear.
- Do not operate machine on hillsides or slopes exceeding 15°.
- Avoid turning on slopes. If you must turn, turn slowly and gradually downhill, if possible.
- Do not use a grass catcher on steep slopes. Heavy grass bags could cause loss of control or overturn the machine.
- Use only Toro-approved attachments. Warranty may be voided if used with unapproved attachments.

# Slope Chart

Read all safety instructions in this manual and on the traction unit.

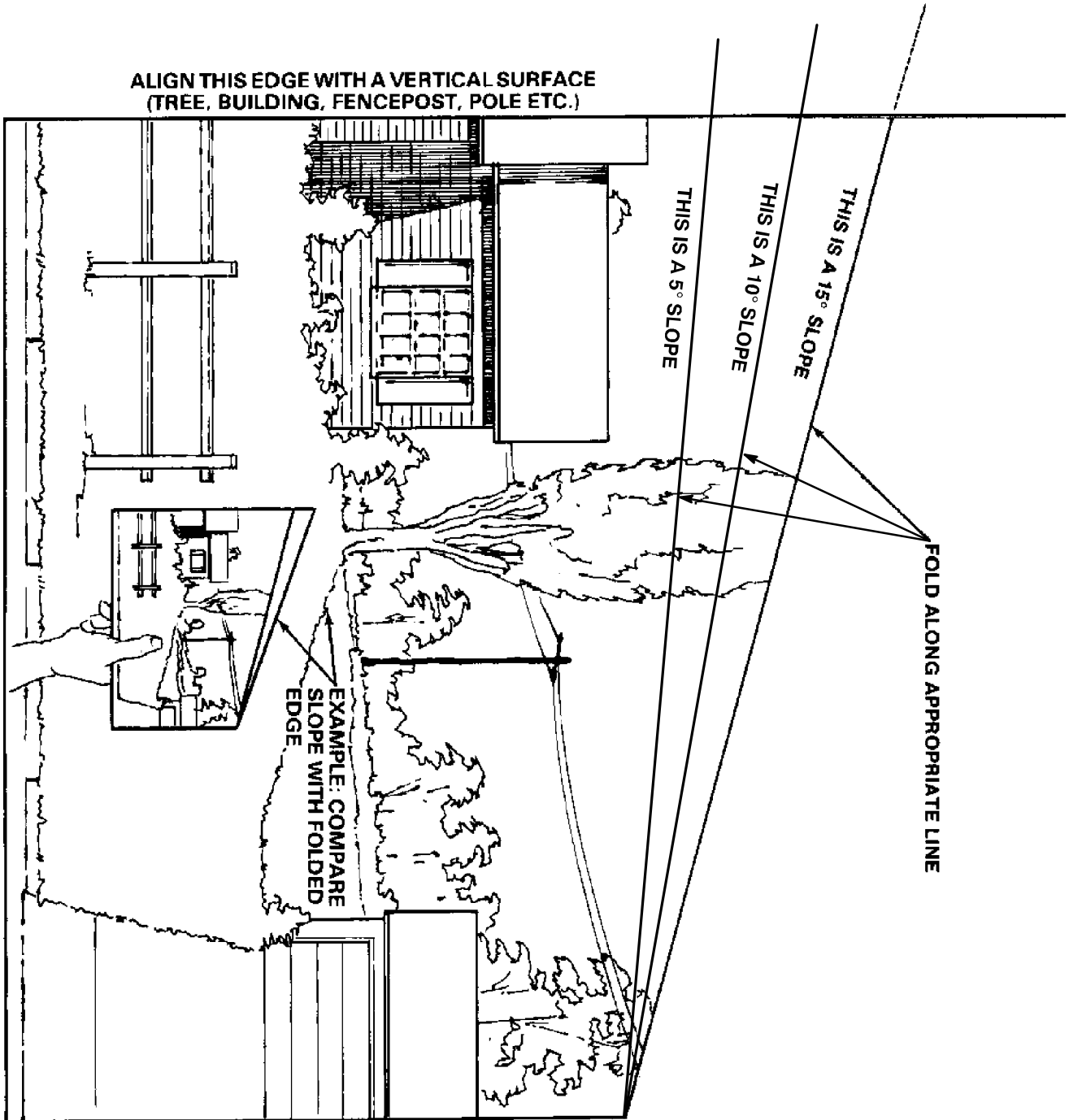



# Safety and Instruction Decals



Safety decals and instructions are easily visible to the operator and are located near any area of potential danger. Replace any decal that is damaged or lost.

**On the drive shaft cover  
(Part No. 99-6090)**

**TRACTION CONTROL PEDAL**

**PARKING BRAKE**

TO SET: DEPRESS BRAKE PEDAL AND LIFT LEVER  
TO RELEASE: DEPRESS BRAKE PEDAL

**BRAKE PEDAL**

**▲ DANGER**

**TO AVOID SERIOUS INJURY OR DEATH,**

- READ AND UNDERSTAND THE OPERATOR'S MANUAL.
- KNOW LOCATION AND FUNCTION OF CONTROLS.
- NEVER USE WHEN UNDER THE INFLUENCE OF ALCOHOL OR DRUGS.
- USE SAFELY; MACHINE IS NOT A TOY; NEVER LET CHILDREN OPERATE.
- KEEP SAFETY DEVICES IN PLACE & WORKING; CHECK BEFORE EACH USE.
- SAFETY INTERLOCKS CAN FAIL; NEVER ASSUME BLADE IS STOPPED.
- STOP ENGINE, SET PARKING BRAKE AND REMOVE BOTH KEYS IF LEAVING MACHINE.
- REMOVE OBJECTS THAT COULD BE THROWN BY THE BLADE.
- GO UP AND DOWN SLOPES, NOT ACROSS.
- AVOID SHARP OR SUDDEN TURNS AND SLIPPERY OR STEEP AREAS.
- IF MACHINE STOPS GOING UPHILL, STOP BLADE & BACK SLOWLY DOWN.

• ROTATING BLADES CAN CUT OFF ARMS AND LEGS.  
• NEVER MOW WHEN CHILDREN OR OTHERS ARE NEAR.  
• NEVER CARRY CHILDREN EVEN WITH BLADES OFF.  
• LOOK DOWN AND BEHIND BEFORE AND WHILE BACKING UP.

REPLACEMENT MANUAL AVAILABLE BY SENDING COMPLETE MODEL NUMBER TO:  
NEW HOLLAND NORTH AMERICA, INC., 500 DILLER AVE., NEW HOLLAND, PA 17557.

**On the front of the  
seat bracket  
(Part No. 99-5339)**

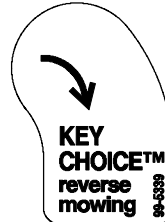

**▲ DANGER**

**NEVER MOW IN REVERSE IF THERE IS ANY POSSIBILITY OF CHILDREN APPEARING IN THE MOWING AREA.** 99-2985

**On the front of the  
seat bracket  
(Part No. 99-2985)**

**On the radiator fan shroud  
(Part No.95-4143)**

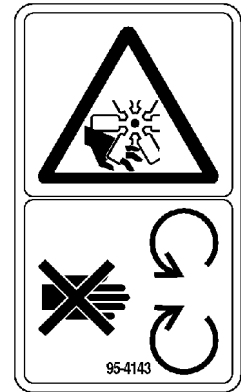

**On the battery strap  
(Part No. 93-1265)**

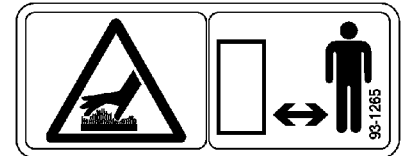

**▲ DANGER**

DO NOT OPERATE THIS UNIT. 80-8760  
DRIVE SHAFT GUARD IS NOT IN PLACE.

**On the drive shaft tunnel  
(Part No. 80-8760)**

5XI SERIES QUICK REFERENCE AID					
MODEL NUMBER	73471/518X1	73542/520X1	73561/522X1	73547/520LX1	73522/523DX1
<b>PART NUMBERS</b>					
TRANSAXLE FILTER	79-5270	79-5270	79-5270	79-5270	79-5270
FAN BELT				95-9784	99-9156
OIL FILTER	12 050 01	12 050 01	12 050 01	95-9763	99-9017
AIR ELEMENT	47 083 03	47 083 03	47 083 03	95-9889	93-2195
AIR PRE-CLEANER	24 083 02	24 083 02	24 083 02	95-9898	
SPARK PLUG	12 132 02	12 132 02	12 132 02	95-9833	
FUEL FILTER	25 050 05	25 050 05	25 050 05	95-9962	63-8300
MOWER MODEL NUMBERS-	78353 - 42 RD	78357 - 44"	78363 - 48"	78370 - 52"	78395 - 60"
MOWER DRIVE BELTS	95-4093	95-4094	95-4095	95-4094	95-4093
SPINDLE BELT	95-4230	95-4228	95-3878	95-2501	95-4229
<b>SUGGESTED MAINTENANCE</b>					
A. ENGINE OIL*	CHECK LEVEL - BEFORE EVERY USE			*PERFORM MORE SCHEDULED MAINTENANCE MORE OFTEN IN DUSTY, DIRTY CONDITIONS	
B. AIR INTAKE SCREENS-CLEAN FOR LIQUID-COOL MODELS ONLY	BEFORE EVERY USE / STORAGE SERVICE	C. ENGINE AIR FILTER-REPLACE		EVERY 100 HRS / STORAGE SERVICE	
D. TRANSAXLE FLUID -	CHECK OIL LEVEL - 25HRS	CHANGE OIL FILTER - FIRST 20HRS THEN EVERY 200HRS / STORAGE SERVICE		For complete maintenance schedules refer to your Toro Wheel Horse Owners Manual.	
E. BATTERY - CHECK ELECTROLYTE	25HRS / STORAGE SERVICE			For dealer locator and more information on Toro products, contact: www.toro.com	
F. CHECK COOLING -	BEFORE EVERY USE				

**Under the hood  
(Part No. 100-7304)**

**▲ WARNING** 98-5014

DO NOT OPERATE THIS UNIT UNLESS HOOD SIDE PANELS ARE IN PLACE.

**(2) Under the side shield  
(Part No. 98-5014)**

# Check Before Operating

Each time before operating your tractor, check the following:

- Fuel level
- Engine oil level
- Cooling system fluid level and radiator screen
- Debris on the (3) air intake screens
- Debris in the engine area
- Debris on the rear transaxle cover
- The safety interlock system
- The brake

Some of these steps will require that you open the hood or remove the side panels on the tractor.

## Opening the Hood

To open the hood:

1. Park the machine on a level surface, disengage the power take off (PTO), set the parking brake, lower the attachment lift, and turn the ignition key to “STOP” to stop the engine. Remove the ignition key.
2. Push the hood latch (Fig. 1), located just above the indicator light panel, to the left.
3. Raise the hood to full height.

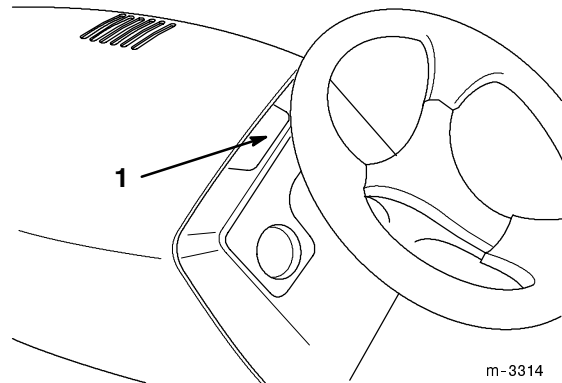

Figure 1

1. Hood latch

### CAUTION

#### POTENTIAL HAZARD

- **Components under the hood will be hot if the tractor has been running.**

#### WHAT CAN HAPPEN

- **Touching hot components can cause burns.**

#### HOW TO AVOID THE HAZARD

- **Allow the tractor to cool before performing maintenance or touching components under the hood.**

## Closing the Hood

The hood catch is located at the left hand corner of the grille.

1. Press rearward on the hood catch as you begin to lower the hood.
2. Push the hood down until the latch closes.

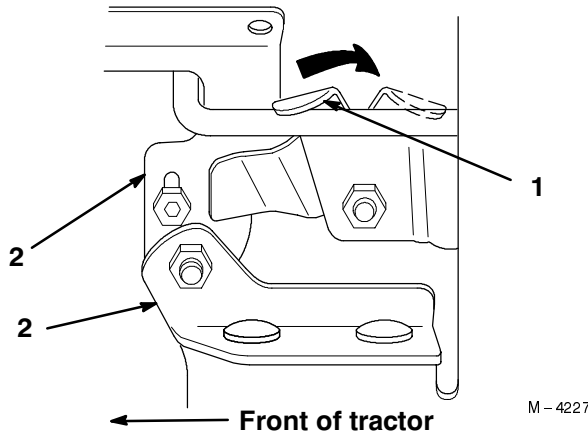

Figure 2

1. Hood catch
2. Hood hinges

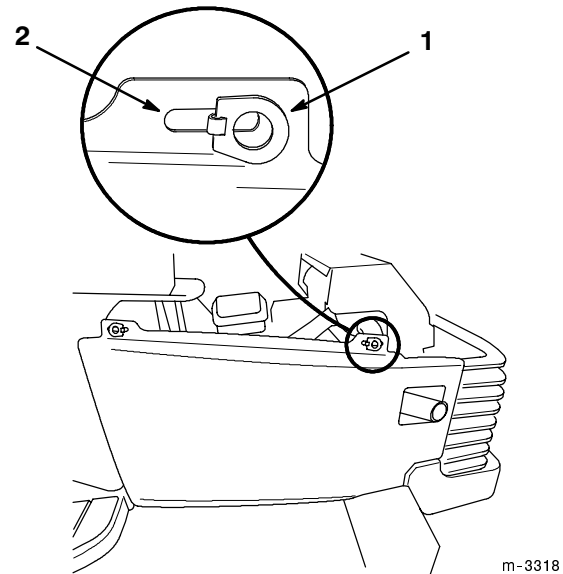

Figure 3

1. Side panel latch
2. Open slot

## Removing the Side Panels

1. Park the machine on a level surface, disengage the power take off (PTO), set the parking brake, lower the attachment lift, and turn the ignition key to "STOP" to stop the engine. Remove the ignition key.
2. To remove a side panel:
  - A. Lift up and twist each of the two side panel latches 90°, or until they line up with the open slot (Fig. 3).
  - B. Pull the top of the side panel toward you until the side panel latches pass through the open slot.
  - C. Lift the side panel from the tractor.

### DANGER

#### POTENTIAL HAZARD

- Rotating fan and drive shaft can cause injury.

#### WHAT CAN HAPPEN

- Fingers, hands or loose clothing can get caught by rotating fan and drive shaft.

#### HOW TO AVOID THE HAZARD

- Do not operate the tractor without the side panels and hood in place.
- Keep fingers, hands and clothing clear of rotating fan and drive shaft.
- Shut off the engine and remove the ignition key before performing maintenance.

## Adding Fuel

Use UNLEADED Regular Gasoline suitable for automotive use (85 pump octane minimum). Leaded regular gasoline may be used if unleaded regular is not available.

**IMPORTANT:** Never use methanol, gasoline containing methanol, or gasohol containing more than 10% ethanol because the fuel system could be damaged. Do not mix oil with gasoline.

### DANGER

#### POTENTIAL HAZARD

- In certain conditions gasoline is extremely flammable and highly explosive.

#### WHAT CAN HAPPEN

- A fire or explosion from gasoline can burn you, others, and cause property damage.

#### HOW TO AVOID THE HAZARD

- Fill the fuel tank outdoors, in an open area, when the engine is cold. Wipe up any gasoline that spills.
- Do not fill the fuel tank completely full. Add gasoline to the fuel tank until the level is 1/4" to 1/2" (6 mm to 13 mm) below the bottom of the filler neck. This empty space in the tank allows gasoline to expand.
- Never smoke when handling gasoline, and stay away from an open flame or where gasoline fumes may be ignited by a spark.
- Store gasoline in an approved container and keep it out of the reach of children. Never buy more than a 30-day supply of gasoline.

**IMPORTANT:** Never use fuel additives containing methanol or ethanol.

### DANGER

#### POTENTIAL HAZARD

- When fueling, under certain circumstances, a static charge can develop, igniting the gasoline.

#### WHAT CAN HAPPEN

- A fire or explosion from gasoline can burn you and others and cause property damage.

#### HOW TO AVOID THE HAZARD

- Always place gasoline containers on the ground away from your vehicle before filling.
- Do not fill gasoline containers inside a vehicle or on a truck or trailer bed because interior carpets or plastic truck bed liners may insulate the container and slow the loss of any static charge.
- When practical, remove gas-powered equipment from the truck or trailer and refuel the equipment with its wheels on the ground.
- If this is not possible, then refuel such equipment on a truck or trailer from a portable container, rather than from a gasoline dispenser nozzle.
- If a gasoline dispenser nozzle must be used, keep the nozzle in contact with the rim of the fuel tank or container opening at all times until fueling is complete.

## Using Stabilizer/Conditioner

Use a fuel stabilizer/conditioner in the machine to provide the following benefits:

- Keeps gasoline fresh during storage of 90 days or less. For longer storage, drain the fuel tank.
- Cleans the engine while it runs.
- Eliminates gum-like varnish buildup in the fuel system, which causes hard starting.

**IMPORTANT: Do not use fuel additives containing methanol or ethanol.**

Add the correct amount of gas stabilizer/conditioner to the gas.

**Note:** A fuel stabilizer/conditioner is most effective when mixed with fresh gasoline. To minimize the chance of varnish deposits in the fuel system, use fuel stabilizer at all times.

**Filling the Fuel Tank**

1. Park the machine on a level surface, disengage the power take off (PTO), set the parking brake, lower the attachment lift, and turn the ignition key to “STOP” to stop the engine. Remove the ignition key.
2. Clean around the fuel tank cap and remove the cap. Use a funnel and add fuel until the fuel level is 1/4 to 1/2 inch (6 mm to 13 mm) below the bottom of the filler neck. This space in the tank allows for expansion of the fuel. When filling the tank, make sure that the machine is on a level surface so that adequate air space is allowed. Do not fill the fuel tank completely.
3. Install the fuel tank cap securely. Wipe up any gasoline that may have spilled.

**Check the Engine Oil Level**

1. Park the machine on a level surface, disengage the power take off (PTO), set the parking brake, lower the attachment lift, and turn the ignition key to “STOP” to stop the engine. Remove the ignition key.
2. Open the hood.
3. Clean around the oil dipstick (Fig. 4) so dirt cannot fall into the dipstick hole and damage the engine.
4. Pull out the oil dipstick and wipe the metal end clean (Fig. 5).

5. Slide the oil dipstick fully into the tube. Pull the dipstick out and look at the metal end. If the oil level is near or below the “L” mark on the dipstick, remove the filler cap and add oil only to the “H” mark on the dipstick. (Refer to Engine Oil, page 28, for the correct oil type and viscosity to use in different temperature conditions).

**IMPORTANT: Do not overfill the crankcase with oil because this may result in engine damage.**

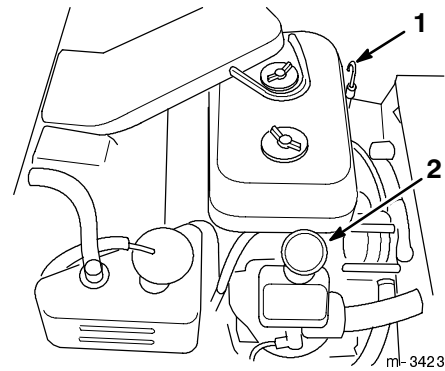

**Figure 4**

1. Dipstick
2. Filler Cap

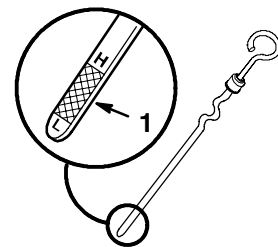

**Figure 5**

1. Metal end

**Check the Cooling System**

**Check Radiator Coolant**

The cooling system is filled with a 50/50 solution of water and permanent ethylene glycol anti-freeze. Check the level of coolant at the beginning of each day before starting the engine.

**! DANGER**

**POTENTIAL HAZARD**

- Coolant is hot and pressurized.

**WHAT CAN HAPPEN**

- Discharge of hot pressurized coolant can cause severe burns.

**HOW TO AVOID THE HAZARD**

- Do not remove the radiator cap to check coolant. Follow the directions below for checking coolant.
- Do not remove the radiator cap when the engine is hot. Always allow the engine to cool at least 15 minutes or until the radiator cap is cool enough to touch without burning your hand before removing the radiator cap.

1. Park the machine on a level surface, disengage the power take off (PTO), set the parking brake, lower the attachment lift, and turn the ignition key to “STOP” to stop the engine. Remove the ignition key.
2. Open the hood.
3. Check coolant level. Coolant should be between the two lines on the reserve tank when the engine is cold (Fig. 6).

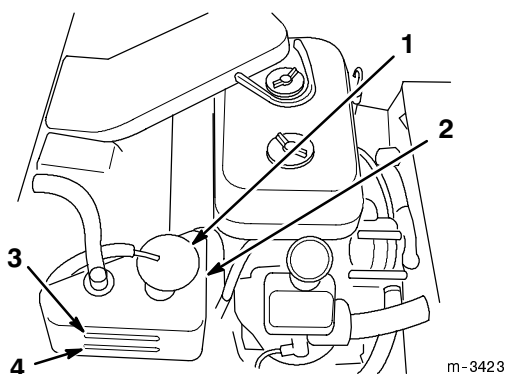

**Figure 6**

- |                     |                              |
|---------------------|------------------------------|
| 1. Reserve tank cap | 3. Maximum level line (cold) |
| 2. Reserve tank     | 4. Minimum level line (cold) |

4. If coolant is low, remove the reserve tank cap and add a 50/50 mixture of water and permanent ethylene glycol anti-freeze. DO NOT OVERFILL.
5. Install the reserve tank cap.

## Check for Debris

**IMPORTANT: Operating the engine with a blocked grass screen and/or cooling shrouds removed, will result in engine damage from overheating.**

1. Park the machine on a level surface, disengage the power take off (PTO), set the parking brake, lower the attachment lift, and turn the ignition key to “STOP” to stop the engine. Remove the ignition key.
2. Check for debris on the (3) air intake screens (Fig. 7). Wipe away debris before each use and/or during use, if required.

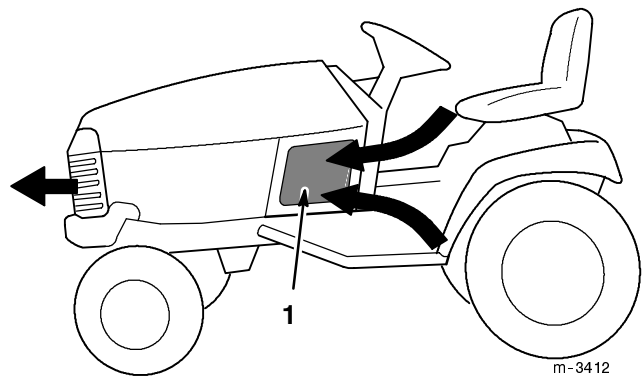

**Figure 7**

Arrows show air intake and exhaust path

1. Air intake screens (1 of 3 shown)

3. The radiator screen (Fig. 8) is located between the radiator and the dash in the tractor. To remove it, pull it up from its retention slot. Wipe or wash off all accumulated debris from the screen, then reinstall it.

- In dry or dusty conditions, dust can build up on the radiator fins and reduce cooling efficiency. Remove the radiator screen and blow (or low pressure wash) the radiator cooling fins.

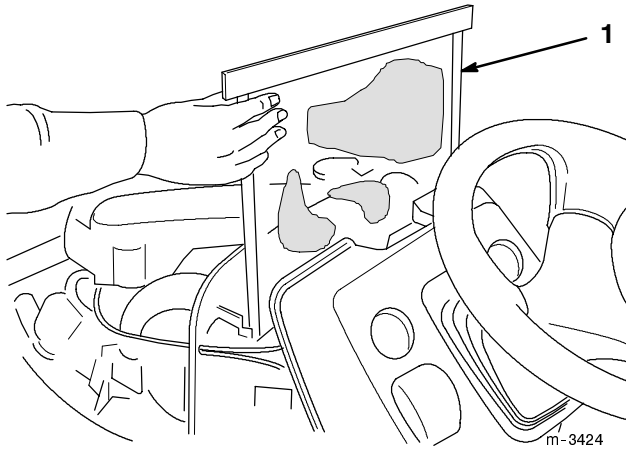

Figure 8

- Radiator screen

- Debris can build up in the engine area. Clean any debris build-up with a brush or blower before each use.

**IMPORTANT: It is preferable to blow dirt out (Fig. 9), rather than washing it out. If water is used, keep it away from electrical items.**

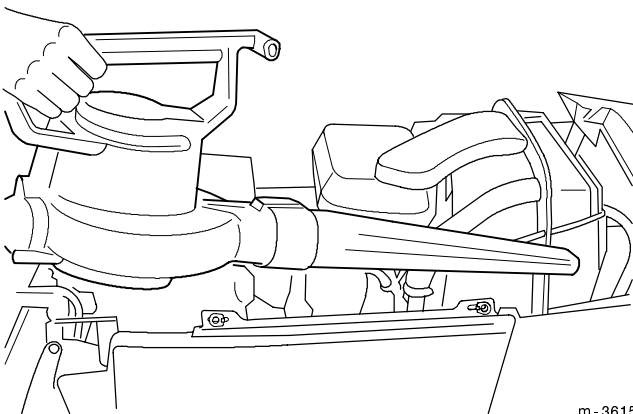

Figure 9

**IMPORTANT: DO NOT HIGH-PRESSURE WASH. High-pressure washing can damage the electrical system or deplete grease.**

- The rear transaxle cover is an air intake area for cooling the transaxle. Clean debris from the rear transaxle cover before operating the tractor (Fig. 10).

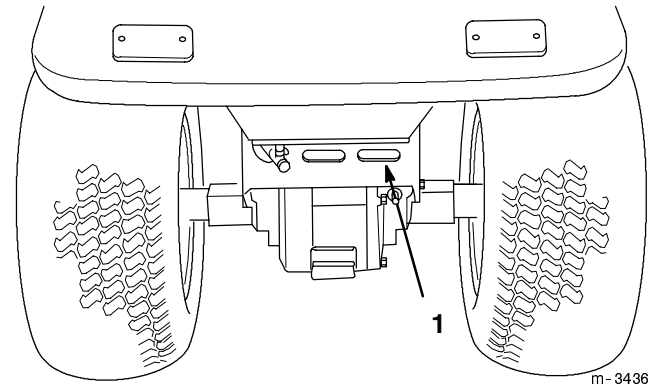

Figure 10

- Rear transaxle cover

## Check the Safety Interlock System

Always check the interlock system before operating the tractor. Instructions for checking the interlock system are found in the Operation section, page 14.

## Check the Brake

Refer to Checking and Adjusting the Brake, page 34.

# Operation

## Think Safety First

Please carefully read all the safety instructions on pages 2-7. Knowing this information could help you, your family, pets or bystanders avoid injury.

## Controls

Become familiar with all the controls (Fig. 11) before you start the engine and operate the machine.

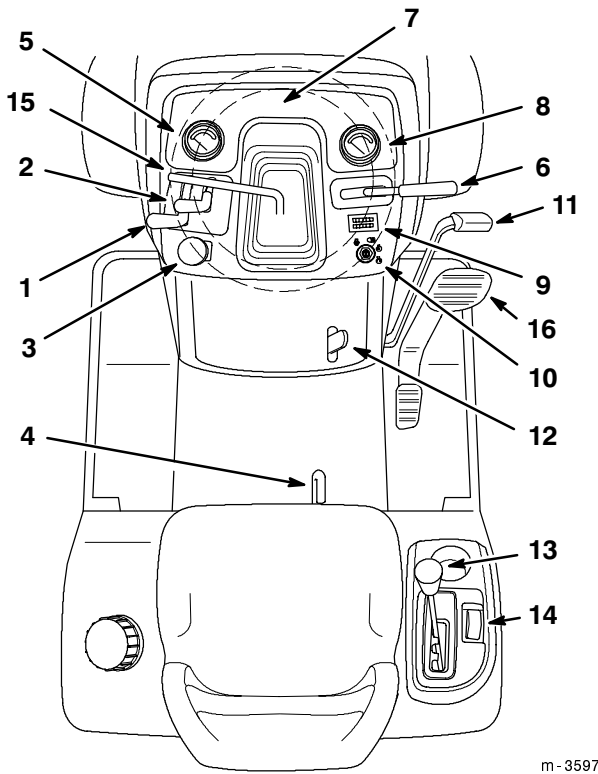

Figure 11

m-3597

- |                                   |                               |
|-----------------------------------|-------------------------------|
| 1. Throttle                       | 9. Hour meter                 |
| 2. Choke                          | 10. Ignition switch           |
| 3. PTO switch                     | 11. Brake pedal               |
| 4. Seat adjustment lever          | 12. Parking brake lever       |
| 5. Engine water temperature gauge | 13. High-Low range lever      |
| 6. Attachment lift lever          | 14. Cruise control switch     |
| 7. Indicator lights               | 15. Steering wheel tilt lever |
| 8. Fuel gauge                     | 16. Traction control pedal    |

## Parking Brake

Always set the parking brake when you stop the machine or leave it unattended.

### Setting the Parking Brake

1. Push the brake pedal (Fig. 11) down and hold it in the depressed position.
2. Lift the parking brake lever (Fig. 11) up and gradually take your foot off the brake pedal. The brake pedal should stay in the depressed (locked) position.

### Releasing the Parking Brake

1. Push down on the brake pedal (Fig. 11). The parking brake lever should release.
2. Release the brake pedal.

## Starting and Stopping the Engine

### Starting

1. Sit down on the seat.
2. Depress the brake pedal.

**Note:** The engine will not start unless you fully depress the brake pedal.

3. Push the PTO (power take off) switch to OFF (Fig. 12).
4. Move the choke lever to ON (if the engine is cold) (Fig. 12).
5. Move the throttle lever halfway to FAST (Fig. 12).

- Turn the ignition key clockwise and hold it in the START position (Fig. 13). When the engine starts, release the key.

**IMPORTANT: Do not run the starter motor more than 5 seconds at a time or premature starter failure may result. If the engine fails to start after 5 seconds, turn the key to the OFF position, recheck the controls and procedures, wait 10 additional seconds and repeat the starting operation; refer to Troubleshooting, page 48.**

- After the engine starts, gradually move the choke lever to OFF (Fig. 12). If the engine stalls or hesitates, move the choke lever back to ON for a few seconds. Then move the throttle lever to the desired setting.

**Note:** Allowing the engine to warm up before putting it under load will lengthen engine life.

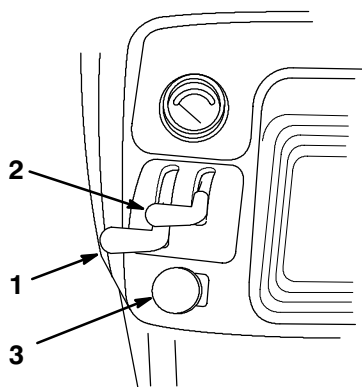
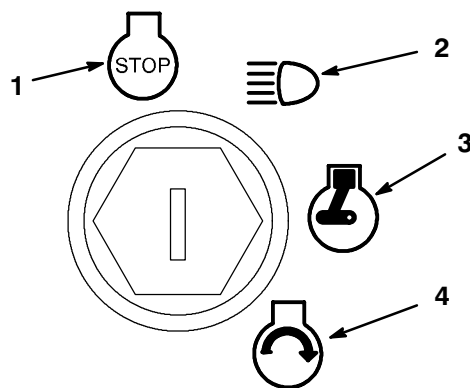

Figure 12

- Throttle
- Choke
- PTO switch

m-3257



m-3312

Figure 13

- Stop
- Run with lights
- Run
- Start

### Stopping

- Move the throttle lever to SLOW (Fig. 12).
- Allow the engine to run for a short time to cool down.
- Turn the ignition key to “STOP” (Fig. 13).
- Always remove both the ignition and “Key Choice” keys when the equipment is not in use or unattended.

### Operating the Power Take Off (PTO)

The power take-off (PTO) switch engages and disengages power to the electric clutch.

If the ignition key is in the RUN or LIGHTS position and the power take off (PTO) is engaged, the PTO indicator light will be on. When this light is on, it is a reminder: the implement is being powered and the starter will not crank while the PTO is engaged. Always turn off the PTO before getting off the seat.

## Engaging the Power Take Off (PTO)

1. Depress the brake pedal to stop the machine.
2. Move the throttle lever to FAST.

**IMPORTANT: For best performance, always use full throttle when the power take off (PTO) switch is ON.**

3. Pull the power take off (PTO) switch to ON (Fig. 14).

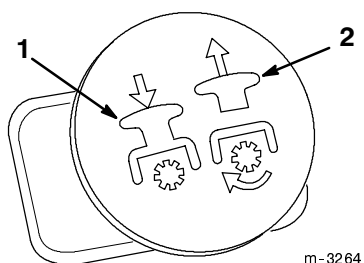

Figure 14

1. Push (off-disengaged)
2. Pull (on-engaged)

## Disengaging the Power Take Off (PTO)

1. Push the power take off (PTO) switch to OFF.

## The Safety Interlock System

### Understanding the Safety Interlock System

The safety interlock system is designed to prevent the engine from starting unless:

- You are sitting on the seat
- The brake pedal is depressed
- The power take off (PTO) is OFF

The safety interlock system is designed to stop the engine if:

- You rise from the seat when the brake pedal is released

- You rise from the seat when the power take off (PTO) is “ON”.

The safety interlock system is designed to stop the power take off (PTO) if:

- You shift into reverse with the power take off (PTO) engaged.

## Operating—in–Reverse

An interlock feature is provided that prevents the Power Take Off (PTO) from operating while the tractor is traveling in reverse. If the unit is shifted into reverse while the mower blade or other PTO driven attachment is engaged, the PTO will stop.

**Do not mow while backing up unless it is absolutely necessary.** If you need to mow while in reverse gear or use other PTO driven attachments (such as a snowthrower or tiller), this no operating-in-reverse interlock may be temporarily deactivated.

Before deactivating this interlock, be sure there are no children present on or near the property where you are using the tractor, and that none are likely to appear while you are mowing or operating an attachment. Be extra observant after you have chosen to deactivate the interlock because the sound of the tractor’s engine might prevent you from being aware that a child or a bystander has entered the area where you are operating the tractor.

If you are certain that you can safely mow in reverse or operate an attachment, deactivate the no operating-in-reverse interlock by turning the “Key Choice” switch (Fig. 15), located on the seat bracket on the right hand side just below the seat, after engaging the blade (PTO). A red light on the front console (Fig. 16) will turn on as a reminder that the no operating-in-reverse interlock has been deactivated. Once the interlock is deactivated it stays in this mode—with your mower blade or PTO-driven attachment operating whenever you back up—and the console light stays on until either the blade (PTO) is disengaged, or the engine is turned off.

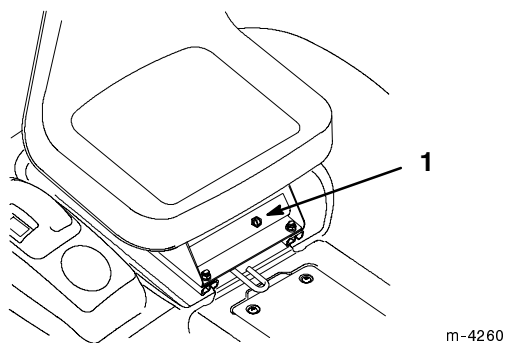

**Figure 15**

1. Reverse interlock key

**Note:** Do not insert the “Key Choice” key unless it is absolutely necessary to mow in reverse or operate an attachment. The “Key Choice” key should also be removed from the unit if it will be operated by someone other than a responsible, experienced operator. This will prevent the unit from operating in reverse with the mower blade or other PTO attachment engaged. Always remove both the ignition and the “Key Choice” keys and put them in a safe place out of the reach of children when leaving the unit unattended.

## **! DANGER**

### **POTENTIAL HAZARD**

- A child or bystander could be backed over by a riding mower with its blade(s) engaged.

### **WHAT CAN HAPPEN**

- Blade contact will cause serious personal injury or death.

### **HOW TO AVOID THE HAZARD**

- Do not mow in reverse unless absolutely necessary.
- Always look backward and down before backing up.
- Use “Key Choice” key only if you are certain no children or other bystanders will appear in the mowing area.
- Always remove both the ignition and “Key Choice” keys and put them in a safe place out of the reach of children or unauthorized users when leaving the unit unattended.

## **Testing the Safety Interlock System**

Test the safety interlock system each time before you use the machine. Do not operate the machine if the safety system is not functioning properly. If the safety system does not operate as described below, have an Authorized Service Dealer repair the safety system immediately.

1. Fully depress the brake pedal. Pull the power take-off (PTO) switch to ON. Now turn the ignition key to START. The starter should not crank.
2. Push the power take-off (PTO) switch to OFF and release the brake pedal. Now turn the ignition key to START; the starter should not crank.
3. Fully depress the brake pedal and set the parking brake. Push the PTO switch to OFF and rise from the seat. Now turn the ignition key to START. The starter should not crank.

4. Fully depress the brake pedal and set the parking brake. Push the power take-off (PTO) switch to OFF. Now start the engine. While the engine is running, release the parking brake and rise slightly from the seat; the engine should stop.
5. Fully depress the brake pedal, set the parking brake, push the PTO switch to OFF and start the engine. Pull the PTO switch to ON. Rise slightly from the seat; the engine should stop.
6. With the parking brake released, turn the ignition key to RUN without starting the engine. Pull the PTO switch to ON. You should hear an audible click indicating the PTO is activated and the PTO light will illuminate. Move the foot pedal to reverse. You should hear an audible click indicating the PTO is deactivated and the PTO light should turn off.
7. With the parking brake released, turn the ignition switch to RUN without starting the engine. Pull the PTO switch to ON. Turn the “Key Choice” key and release. The Operating-in-Reverse warning light should illuminate. Move the foot pedal to reverse. The PTO and PTO light on the dash should remain on. Push the PTO switch to OFF. The PTO light and the Operating-in-Reverse warning light should turn off.

## Gauges and Indicator Lights

The indicator lights (Fig. 16) illuminate when certain controls are activated and when major malfunctions occur that need immediate attention.

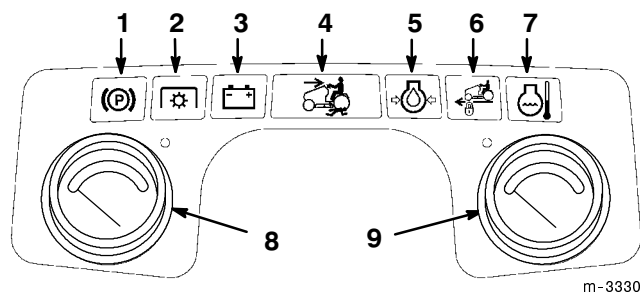

Figure 16

- |                                       |                                     |
|---------------------------------------|-------------------------------------|
| 1. Parking brake light                | 6. Cruise control light             |
| 2. PTO (power take off) light         | 7. Coolant temperature light        |
| 3. Battery light                      | 8. Engine coolant temperature gauge |
| 4. Operating-in-Reverse warning light | 9. Fuel gauge                       |
| 5. Oil pressure light                 |                                     |

### Parking Brake Light

When the parking brake light is ON it indicates the parking brake is set. The machine will not drive while the parking brake is set.

### PTO (Power Take Off) Light

When the PTO (power take off) light is ON it indicates the implement is being powered. The PTO clutch must be disengaged before the engine will start.

### Battery Light

The battery light will be ON when the key is in the RUN or LIGHTS positions if the battery voltage is below 12.1 volts or above 15.0 volts. If the light comes on at a higher RPM, it is important to have your battery and electrical system checked and the problem corrected.

## Operating-in-Reverse Warning Light

The Operating-in-Reverse warning light will illuminate whenever the “Key Choice” key is used to deactivate the operating-in-reverse interlock. It is a reminder that the interlock system is deactivated. The light goes out whenever the power take off (PTO) is disengaged or the engine is shut off. **When the light is on, look behind and use extra caution when backing. Be especially watchful for children and pets.**

## Oil Pressure Light

When the oil light is ON it indicates the engine oil pressure is low. After the engine starts the light should go out. When the engine is running, the light comes ON if the oil pressure drops below a safe operating level. If the light comes on while the engine is running, **stop the engine immediately and correct the cause of low oil pressure.**

## Cruise Control Light

The cruise control light indicates that the cruise control system is activated.

## Coolant Temperature Light

The coolant temperature light shows when the engine cooling system is overheated. The light indicates to check the gauge and follow the cautions, below.

## Engine Coolant Temperature Gauge

This gauge shows the coolant temperature in the engine. If the gauge enters the red zone, disengage the PTO and allow the engine to cool while continuing to run the engine.

If the gauge does not show temperatures dropping, **stop the engine immediately, clean the air intake screens, and/or correct the cause of high temperature.**

## Fuel Level Gauge

This gauge shows the level of fuel remaining.

## Hour Meter

The hour meter (Fig. 11) records the amount of time the engine has run. Use it to schedule regular maintenance.

## Driving Forward or Backward

1. Stop the tractor.

**IMPORTANT: Never attempt to shift gears with the tractor in motion. Internal transmission damage may result.**

**IMPORTANT: Do not force the shift lever. Applying slight pressure to the traction control pedal while shifting will help the gears engage.**

2. Shift into high “H” or low “L” forward speed with the High-Low lever (Fig. 11). Use Low for best mowing performance and smoothest operation with all attachments. Use High for transporting or where conditions permit higher speed.

**⚠ DANGER**

**POTENTIAL HAZARD**

- Excessive speed on slopes can result in rollover accidents or loss of control.

**WHAT CAN HAPPEN**

- Rollover accidents or loss of control can result in serious injury or death.

**HOW TO AVOID THE HAZARD**

- Never shift into neutral while moving.
- Never allow tractor to roll freely in neutral on slopes.
- Read, understand, and follow all instructions in the operator’s manual and on the machine before starting.

3. Place the throttle control in the FAST position for best performance. (The throttle control regulates engine revolutions per minute).
4. Place your foot on the traction control pedal and slowly press on the top of the pedal to move forward, or on the bottom of the pedal to move backward (Fig. 17). The farther you move the pedal in either direction, the faster the machine will move in that direction.
5. To slow down, release the pressure on the traction control pedal and step on the brake pedal.

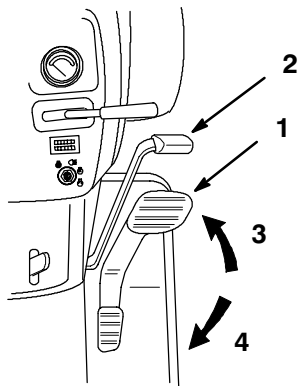

m-3258

**Figure 17**

- |                           |             |
|---------------------------|-------------|
| 1. Traction control pedal | 3. Forward  |
| 2. Brake pedal            | 4. Backward |

## Stopping the Machine

To stop the machine, release the traction control pedal, step on the brake pedal, disengage the power take off (PTO), lower the attachment lift, and turn the ignition key to STOP. Also set the parking brake if you leave the machine unattended; refer to Setting the Parking Brake, page 14. Remember to remove both the ignition and “Key Choice” keys from the switches.

**⚠ CAUTION**

**POTENTIAL HAZARD**

- Someone could move or attempt to operate the tractor while it is unattended.

**WHAT CAN HAPPEN**

- Children or bystanders may be injured if they use the tractor.

**HOW TO AVOID THE HAZARD**

- Always remove both the ignition and “Key Choice” keys, and set the parking brake when leaving the machine unattended, even if just for a few minutes.

## Re-centering the Steering Wheel

The power steering will not always return the steering wheel to the centered position. When this happens, the steering wheel will appear to be un-centered when the front wheels return to the straight-ahead position.

This is not a mechanical problem, but if it happens to your vehicle and you wish to re-center the steering wheel, you may do so:

1. Note the degree to which the steering wheel is out of center, then turn the steering wheel all the way in the opposite direction until the front wheels no longer turn.
2. Continue turning the steering wheel by the degree to which it is off center.
3. Now turn the steering wheel in the other direction until the front wheels aim straight ahead. The steering wheel should now be centered.

## Attachment Power Lift

The attachment power lift (Fig. 18) is used to raise and lower attachments.

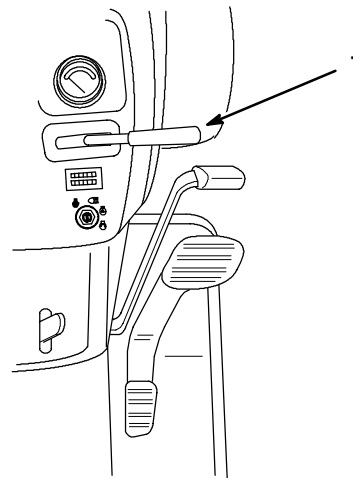

m-3258

**Figure 18**

1. Attachment power lift

## Raising Attachments

1. Start the tractor.
2. Pull the lift lever UP to raise the attachment (Fig. 19). This will lift and hold the attachment in the raised position.

### **WARNING**

#### **POTENTIAL HAZARD**

- When the engine is off, attachments in the raised position can gradually lower.

#### **WHAT CAN HAPPEN**

- Someone nearby may be pinned or injured by the attachment as it lowers.

#### **HOW TO AVOID THE HAZARD**

- Always lower the attachment lift each time you shut off the tractor.

## Lowering Attachments

1. Start the tractor.
2. Push the lift lever **DOWN** to lower the attachment (Fig. 19).

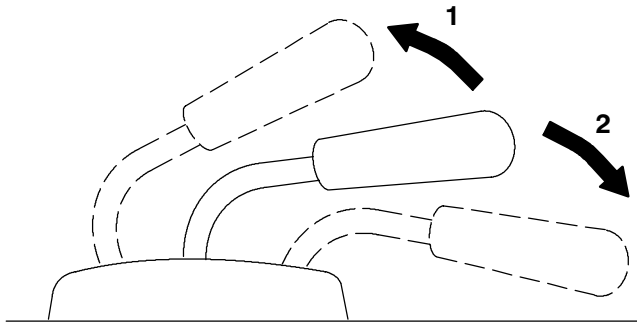

Figure 19

1. Lift lever-Up
2. Lift lever-Down

## Positioning the Seat

The seat can move forward and backward. Position the seat where you have the best control of the machine and are most comfortable.

1. To adjust, move the lever sideways to unlock seat (Fig. 20).
2. Slide the seat to the desired position and release the lever to lock the seat into position.

**IMPORTANT: Be sure that the seat is locked in position before operating.**

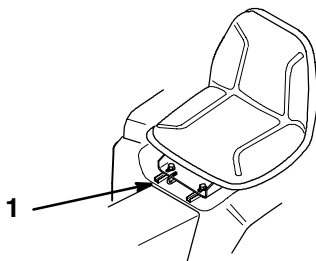

Figure 20

m-3320

1. Adjustment lever

## Headlights and Taillights

The headlights and taillights are turned on by turning the ignition key to the **LIGHTS** position. They can be turned on even if the engine is not running. Remove the ignition key when leaving the machine unattended so that the headlights cannot be turned on and discharge the battery.

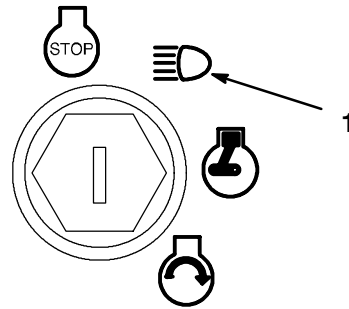

Figure 21

m-3312

1. Lights

## Positioning the Tilt Steering Wheel

The steering wheel has four tilt locations. Position the steering wheel where you have the best control of the machine and are most comfortable.

1. Lift the tilt lever to release the lock (Fig. 22).
2. Move the steering wheel to a comfortable position; then release the lever to lock it in place.

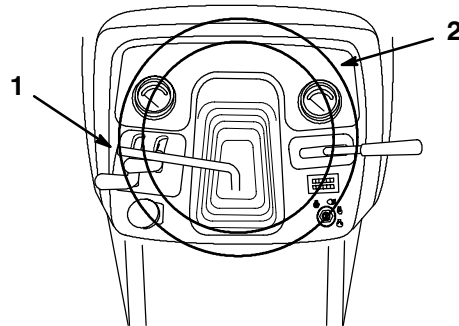

Figure 22

m-3259

1. Tilt lever
2. Steering wheel

## Using the Cruise Control

The cruise control is a switch (Fig. 23) on the right fender that maintains a set traction control position without foot pressure. The cruise control only operates when moving forward.

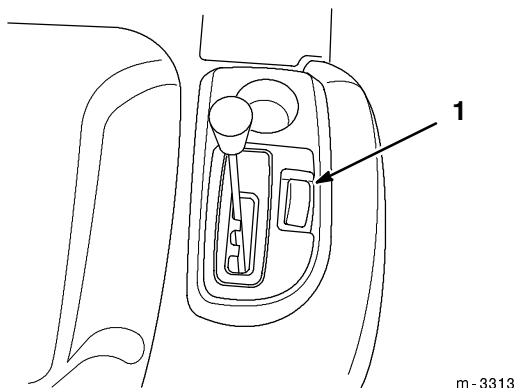

Figure 23

1. Cruise control

## Engaging the Cruise Control

1. Begin driving the tractor; refer to Driving Forward or Backward, page 19. While holding your foot steady on the traction control pedal, push the cruise control switch (Fig. 23) to the “SET” position. This locks the traction control in position and your foot can then be removed from the traction control. A constant pedal position will be maintained.
2. The cruise control has a “speed-up” feature: If you initially set it to any speed other than full speed, you can speed up with your foot on the traction pedal for as long as you wish. When you release the traction pedal, the pre-selected cruise speed resumes automatically.

## Disengaging the Cruise Control

1. While holding your foot steady on the traction control, move the cruise control switch (Fig. 11) to the “OFF” position.
2. This unlocks the traction control. You must now use the traction control to move forward.
3. For quick stops, just press the brake pedal. This automatically disengages the cruise control and applies the brake at the same time.

**IMPORTANT: If you accidentally press the cruise control while the engine is running and you are not moving, the machine will subsequently operate at partial speed in forward and will not operate in reverse.**

**To correct this situation, press the cruise control switch to “OFF,” or press the brake pedal to disengage the cruise control.**

## The Smart Turn™ Steering Feature

The Smart Turn™ Steering feature automatically lowers the speed of the tractor in tight turns. The decrease in speed is directly proportional to the sharpness of the turn, up to a maximum speed reduction of 40 percent. This allows you to make turns at higher speeds without having to change the speed control position. After the turn, the original speed is automatically restored.

The Smart Turn™ Steering feature does not affect engine speed.

This system was set at the factory and should not need adjustment.



## **DANGER**

### **POTENTIAL HAZARD**

- Excessive speed when turning can result in rollover accidents.

### **WHAT CAN HAPPEN**

- Rollover accidents can result in serious injury or death.

### **HOW TO AVOID THE HAZARD**

- Do not rely on the Smart Turn™ Steering feature to avoid accidents while turning.
- Do not set the cruise control at higher speeds when operating on uneven terrain or slopes.
- Read, understand, and follow all instructions in the operator's manual and on the machine before starting.

## **Pushing the Machine by Hand**

**IMPORTANT:** Always push the machine by hand. Never tow the machine because transmission damage may occur.

### **To Push the Machine**

1. Disengage the power take off (PTO) and turn the ignition key to "STOP" to stop the engine.
2. Move the High-Low range lever to the neutral position "N." This allows the rear wheels to turn freely.
3. Place the lever back in High or Low after moving the machine, and set the parking brake.

# Maintenance

## Service Interval Chart

Service Operation	Each Use	5 Hours	25 Hours	50 Hours	100 Hours	200 Hours	300 Hours	Storage Service
Engine Oil—check level	X							X
Engine Coolant—check level	X							X
Radiator Screen—check for debris*	X							X
Brake—check	X							X
Safety System—check	X							X
(3) Air Intake Screens—clean*	X							X
Engine Area—clean*	X							X
Rear Transaxle Cover—clean*	X							X
Engine Air Precleaner—clean*			X					X
Tires—check pressure			X					X
Battery—check electrolyte level			X					X
Transaxle—check oil level			X					
Engine Oil—change		Initial		X				X
PTO (Power Take Off) Belt—check tension		Initial		X				X
Lubrication				X				X
Engine Air Filter—clean*					X			X
Spark Plug(s)—change					X			X
Fuel Filter—replace					X			X
Engine Oil Filter—change					X			X
Transaxle—change oil				Initial		X		X
Transaxle—change oil filter				Initial		X		X
Power Steering Filter—clean				Initial		X		X
Engine Air Filter—replace*							X	X
Chipped Surfaces—paint								X
Radiator—flush and change coolant	Every 400 hours or 2 years, whichever comes first							
* More often in dusty, dirty conditions								

**IMPORTANT:** Refer to your Engine Operator's Manual for additional engine maintenance procedures.

**CAUTION**

**POTENTIAL HAZARD**

- If you leave the key in the ignition switch, someone could start the engine.

**WHAT CAN HAPPEN**

- Accidental starting of the engine could seriously injure you or other bystanders.

**HOW TO AVOID THE HAZARD**

- Remove the key from the ignition switch and pull the wire(s) off the spark plug(s) before you do any maintenance. Also push the wire(s) aside so it does not accidentally contact the spark plug(s).

## Air Cleaner

### Service Interval/Specification

**Foam Precleaner:** Clean and re-oil after every 25 operating hours, or yearly, whichever occurs first.

**Paper Air Filter:** Clean every 100 operating hours, or yearly, whichever occurs first. Replace after every 300 operating hours.

**Note:** Service the air cleaner more frequently (every few hours) if operating conditions are extremely dusty or sandy.

### Removing the Foam and Paper Elements

1. Disengage the power take off (PTO), set the parking brake, lower the attachment lift, and turn the ignition key to “STOP” to stop the engine. Remove the ignition key.
2. Open the hood.
3. Clean around the air cleaner to prevent dirt from getting into the engine and causing damage (Fig. 24).

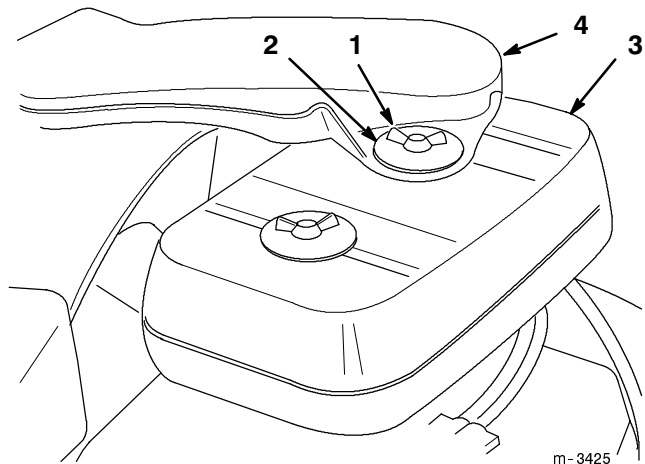

**Figure 24**

- |              |                      |
|--------------|----------------------|
| 1. Wing bolt | 3. Air cleaner cover |
| 2. Washer    | 4. Air intake duct   |
4. Remove the wing bolts, washers, air intake duct, and air cleaner cover (Fig. 24).

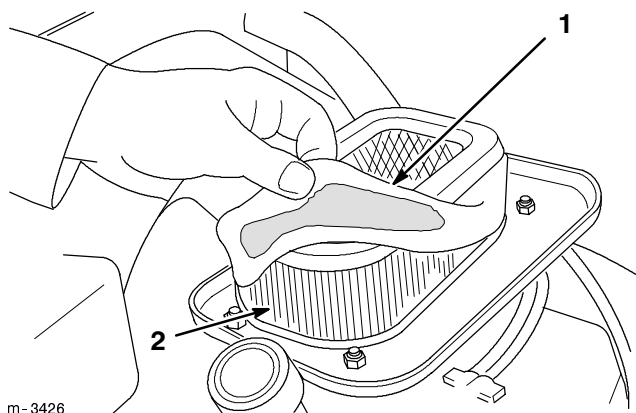

m-3426

Figure 25

1. Foam element                      2. Paper element

5. Remove the elements and separate the foam element from the paper element (Fig. 25).

**IMPORTANT: Do not clean the elements with solvents or compressed air.**

### Cleaning the Foam Element

1. Wash the foam element in liquid soap and warm water. When the element is clean, rinse it thoroughly.
2. Dry the element by squeezing it in a clean cloth.
3. Saturate the element with clean engine oil (Fig. 26), squeeze out the excess oil, the wrap it in a clean rag and squeeze it as dry as possible. Be careful not to tear the element.

**IMPORTANT: Replace the foam element if it is torn or worn.**

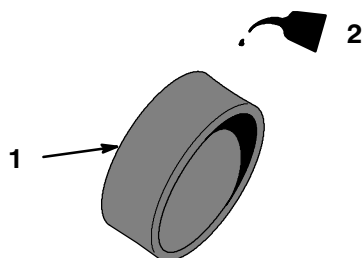

m-3364

Figure 26

1. Foam element                      2. Oil

### Cleaning the Paper Element

1. Clean the paper element by tapping it gently on a flat surface to remove dust.
2. Inspect the element for tears, an oily film, and damage. If the element is very dirty or damaged, replace it with a new one.

**IMPORTANT: Never clean the paper element with pressurized air or liquids, such as solvent, gas, or kerosene. Replace the element if it is damaged or cannot be cleaned thoroughly.**

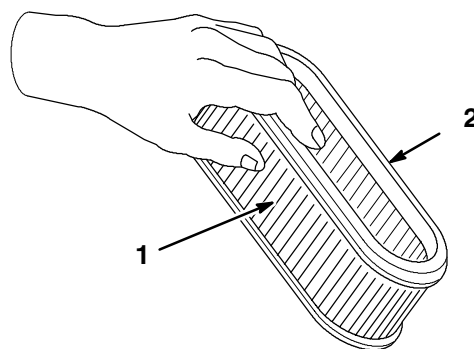

m-3363

Figure 27

1. Paper element                      2. Rubber seal

### Checking the Air Filter Housing

Check the air cleaner housing for deformation or other damage. The housing must seal well and permit only filtered air to reach the carburetor. If the housing is damaged, it must be replaced. Check that no foreign material is obstructing the air passage.

### Installing the Foam and Paper Elements

**IMPORTANT: To prevent engine damage, always operate the engine with the complete foam and paper air cleaner assembly installed.**

1. Carefully slide the foam element onto the paper air cleaner element (Fig. 25).
2. The element installation is performed in the reverse order of removal.

## Engine Oil

### Service Interval/Specification

Change oil:

- After the first 5 operating hours.
- After every 50 operating hours.

**Oil Type:** Detergent oil (API service SG or SH)

**Crankcase Capacity:** w/filter, 1.9 qts. (1.8 l)

**Viscosity:** See the table below.

#### USE THESE SAE VISCOSITY OILS

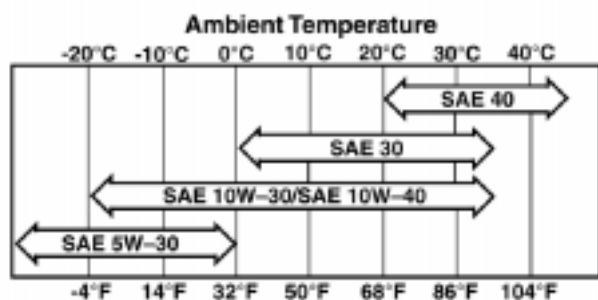

### Changing/Draining the Engine Oil

1. Start the engine and let it run for five minutes. This warms the oil so it drains better.
2. Park the machine so that the drain side is slightly lower than the opposite side to assure the oil drains completely. Then disengage the power take off (PTO), set the parking brake, lower the attachment lift, and turn the ignition key to "STOP" to stop the engine. Remove the ignition key.
3. Open the hood.

### CAUTION

#### POTENTIAL HAZARD

- Components under the hood will be hot if the tractor has been running.

#### WHAT CAN HAPPEN

- Touching hot components can cause burns.

#### HOW TO AVOID THE HAZARD

- Allow the tractor to cool before performing maintenance or touching components under the hood.

4. Place a pan below the oil drain. Open the drain by turning it counterclockwise 1/8 turn and pulling out on it (Fig. 29).
5. When the oil has drained completely, close the drain by pushing it in and turning it clockwise, 1/8 turn.
 

**Note:** Dispose of the used oil at a certified recycling center.
6. Remove the oil filler cap (Fig. 28) and refill the engine with a high-quality, API Service SG or SH engine oil (see viscosity chart).
7. Slowly pour approximately 80% of the specified amount of oil into the filler tube (Fig. 28). Now check the oil level; refer to Checking the Engine Oil Level, page 11. Slowly add additional oil to bring the oil level to the FULL mark on the dipstick.

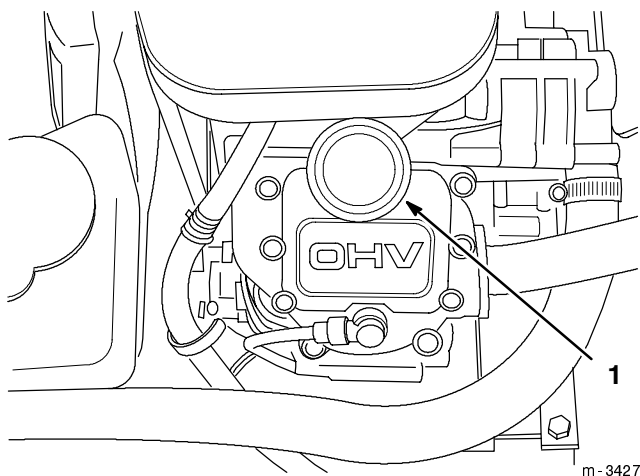

Figure 28

1. Filler cap

8. Check the oil level; refer to Checking the Engine Oil Level, page 11.

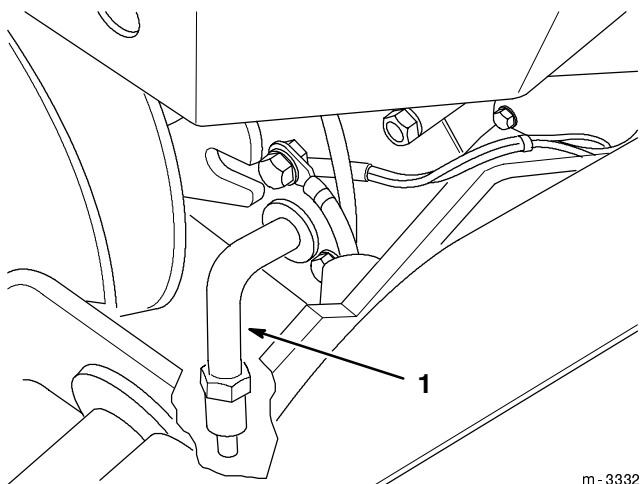

Figure 29

1. Oil drain

**IMPORTANT: Do not overfill the crankcase with oil because this may cause engine damage.**

## Changing the Engine Oil Filter

### Service Interval/Specification

Replace the oil filter after every 100 hours or every other oil change.

1. Drain the oil from the engine; refer to Changing/Draining Oil, page 28.
2. Place a drip pan beneath the oil drip tray to receive oil from the oil filter and oil passages in the engine.
3. Turn the filter counterclockwise to remove it.
4. Install the new filter. Turn the filter until the seal contacts the mounting surface of the engine. Then turn the filter **BY HAND** 3/4 turn more.
5. Remove the oil filler cap and refill the engine with a high-quality, API Service SG or SH engine oil (see viscosity chart, page 28).
6. Run the engine at slow idle speed for two minutes.
7. Stop the engine. Check the oil level; refer to Checking the Engine Oil Level, page 11. Add oil only to the "H" mark on the dipstick.
8. Install the filler cap and dipstick.

**Note:** Dispose of oil filter properly. Recycle in accordance with local codes.

## Changing the Engine Coolant

### **⚠ DANGER**

#### **POTENTIAL HAZARD**

- Coolant is hot and pressurized.

#### **WHAT CAN HAPPEN**

- Discharge of hot pressurized coolant can cause severe burns.

#### **HOW TO AVOID THE HAZARD**

- Do not remove the radiator cap when the engine is hot. Always allow the engine to cool at least 15 minutes or until the radiator cap is cool enough to touch without burning your hand before removing the radiator cap.

1. Park the machine on a level surface, disengage the power take off (PTO), set the parking brake, lower the attachment lift, and turn the ignition key to “STOP” to stop the engine. Remove the ignition key.
2. Remove the radiator cap and reserve tank cap (Fig. 30).

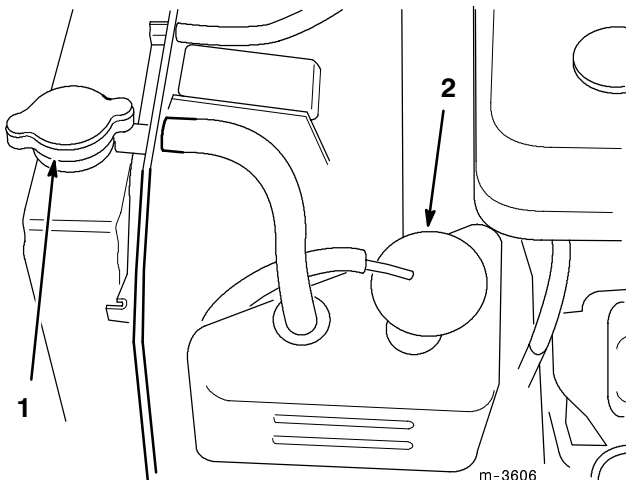

**Figure 30**

1. Radiator cap
2. Reserve tank cap

3. Open the coolant drain at the bottom of the radiator and allow coolant to flow into a drain pan. When coolant stops flowing, close the drain.
4. Remove the coolant plug from the engine and allow coolant to flow into the drain pan. When coolant stops flowing, install the drain plug.
5. Slowly fill the radiator with a 50/50 mixture of water and permanent ethylene glycol anti-freeze. Install the radiator cap.
6. Slowly fill the reserve tank until the level reaches the upper line. **DO NOT OVERFILL.** Install the reserve tank cap.
7. Start the engine and operate it until it is warm. Recheck the coolant level after the engine has cooled down and replenish, if required; refer to Check the Cooling System, page 11.

## Spark Plugs

### Service Interval/Specification

Check the spark plugs and reset the air gap as necessary. Replace the spark plugs after every 100 operating hours. Make sure the air gap between the center and side electrodes is correct before installing the spark plugs. Use a spark plug wrench for removing and installing the spark plugs and a gapping tool/feeler gauge to check and adjust the air gap.

**Type:** NGK BMR4A

**Air Gap:** 0.024-0.028” (0.6-0.7 mm)

**Note:** If you wish, you can attach a 3/8 ID hose to the drain valve.

## Removing the Spark Plugs

1. Disengage the power take off (PTO), set the parking brake, lower the attachment lift, and turn the ignition key to "STOP" to stop the engine. Remove the ignition key.
2. Open the hood.
3. Pull the wire(s) off the spark plug(s) (Fig. 31). Now clean around the spark plug(s) to prevent dirt from falling into the engine and potentially causing damage.
4. Remove the spark plug(s) and metal washer.

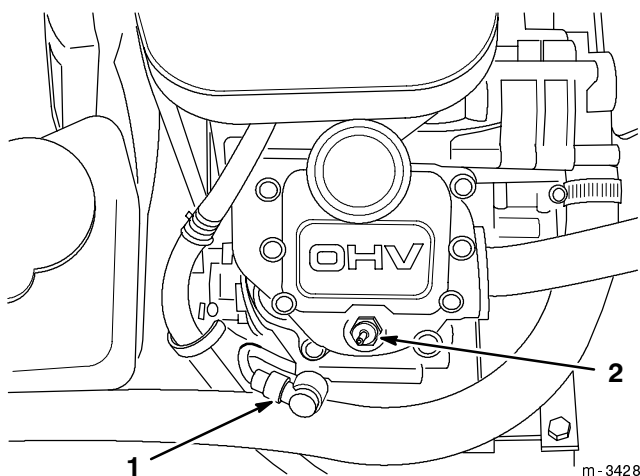

**Figure 31**

1. Spark plug wire
2. Spark plug

## Checking the Spark Plugs

1. Look at the center of the spark plug(s) (Fig. 32). If you see light brown or gray on the insulator, the engine is operating properly. A black coating on the insulator usually means the air cleaner is dirty.

**IMPORTANT: Never clean the spark plug(s). Always replace the spark plug(s) when it has: a black coating, worn electrodes, an oily film, or cracks.**

2. Check the gap between the center and side electrodes (Fig. 32). Bend the side electrode (Fig. 32) if the gap is not correct.

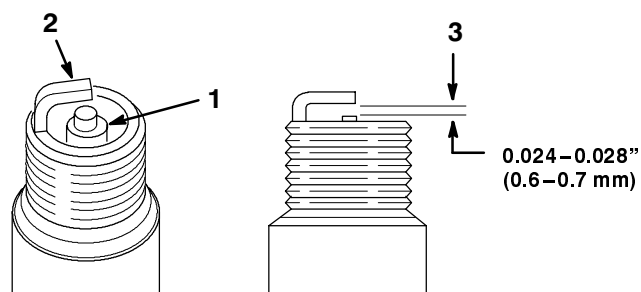

**Figure 32**

1. Center electrode insulator
2. Side electrode
3. Air gap (not to scale)

## Installing the Spark Plug(s)

1. Install the spark plug(s) and metal washer. Make sure the air gap is set correctly.
2. Tighten the spark plug(s) to 15-20 ft-lb (20-27 Nm).

3. Push the wire(s) onto the spark plug(s) (Fig. 31).
4. Close the hood.

## Greasing and Lubrication

### Service Interval/Specification

Grease the machine after every 50 operating hours or yearly, whichever occurs first. Grease more frequently when operating conditions are extremely dusty or sandy.

**Grease Type:** General-purpose grease.

### How to Grease

1. Disengage the power take off (PTO), set the parking brake, lower the attachment lift, and turn the ignition key to “STOP” to stop the engine. Remove the ignition key.
2. Clean the grease fittings with a cloth. Make sure to scrape off any paint from the front of the fitting(s).
3. Connect a grease gun to the fitting. Pump grease into the fittings until grease begins to ooze out of the bearings.
4. Wipe up any excess grease.

### Where to Add Grease

1. Lubricate the left-hand and right-hand spindles until grease begins to ooze out of the bearings (Fig. 33).
2. Lubricate the front axle pivot (Fig. 33).

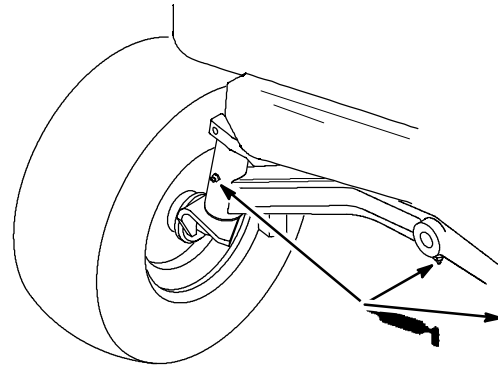

m-3240

**Figure 33**

3. Open the drive shaft maintenance cover on the tractor tunnel near the seat by unscrewing the two screws securing it, then raising it (Fig. 34).

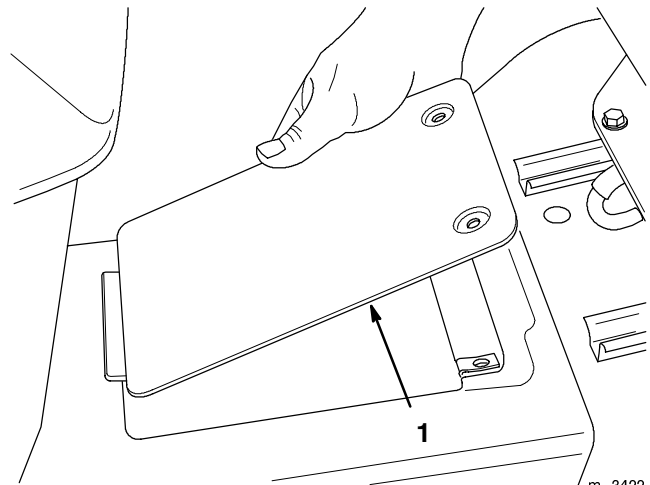

m-3422

**Figure 34**

1. Drive shaft maintenance cover

**! DANGER****POTENTIAL HAZARD**

- Rotating shaft or cooling fan can cause injury.

**WHAT CAN HAPPEN**

- Fingers, hands, feet, hair, etc. can get caught by shaft or fan.
- Loose clothing can get caught by shaft.

**HOW TO AVOID THE HAZARD**

- Do not operate the tractor without the drive shaft cover in place.
- Keep hands and arms clear of rotating shaft or fan.

4. Lubricate the three grease fittings (Fig. 35).

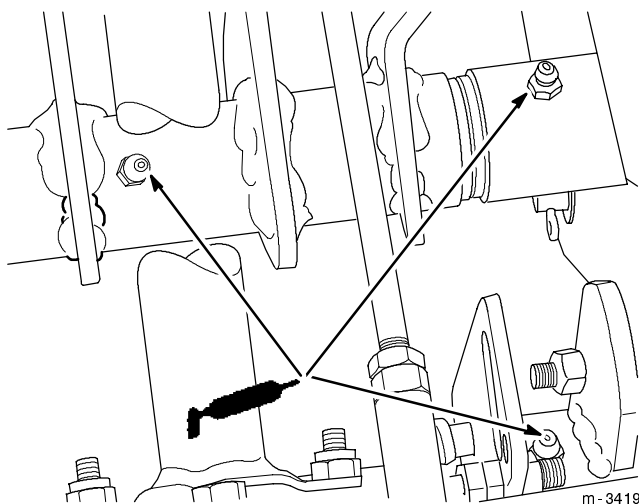
**Figure 35**

5. Replace and secure the cover.
6. Grease the fitting on the brake pedal (Fig. 36).

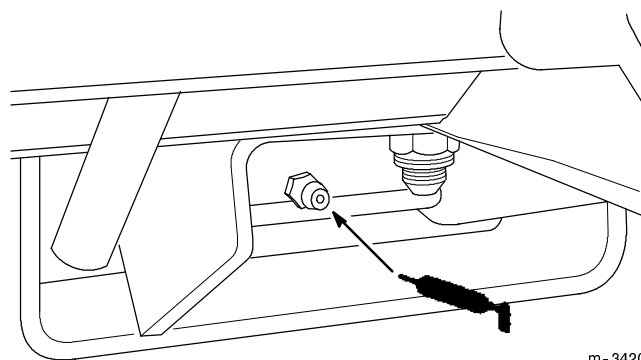
**Figure 36****Tire Pressure****Service Interval/Specification**

Maintain the air pressure in the front and rear tires as specified. Check the pressure at the valve stem after every 25 operating hours or monthly, whichever occurs first (Fig. 37). Check the tires when they are cold to get the most accurate pressure reading.

**Pressure:** 20 psi (138 kPa) front and rear

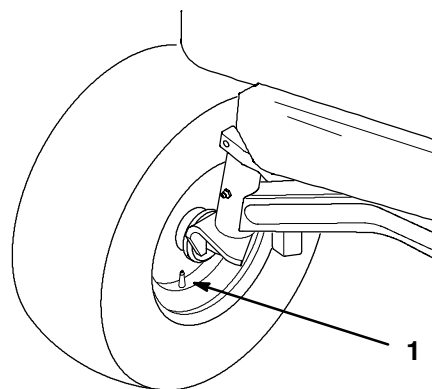
**Figure 37**

1. Valve stem

## Brake

Always set the parking brake when you stop the machine or leave it unattended. Check the brake before each use. If the parking brake does not hold securely, an adjustment is required.

### Checking the Brake

1. Park the machine on a level surface, disengage the power take off (PTO), put the High-Low range lever in "N," set the parking brake, and turn the ignition key to "STOP" to stop the engine. Remove the ignition key.
2. The rear wheels must lock and skid when you try to push the tractor forward. Adjustment is required if the wheels turn and do not lock; refer to Adjusting the Brake.

### Adjusting the Brake

The brake adjustment is at the rear of the tractor (Fig. 39). If the parking brake does not hold securely, an adjustment is required.

1. Check the brake before you adjust it; refer to Checking the Brake.
2. Place the transmission in neutral.
3. Depress the brake pedal. There should be 2" (51 mm) of free travel (Fig. 38) before the brake begins to engage.

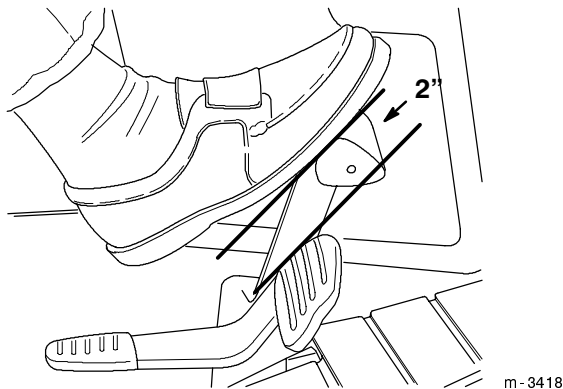

Figure 38

4. Turn the brake adjustment nut (Fig. 39) until there is 2" (51 mm) of free travel.

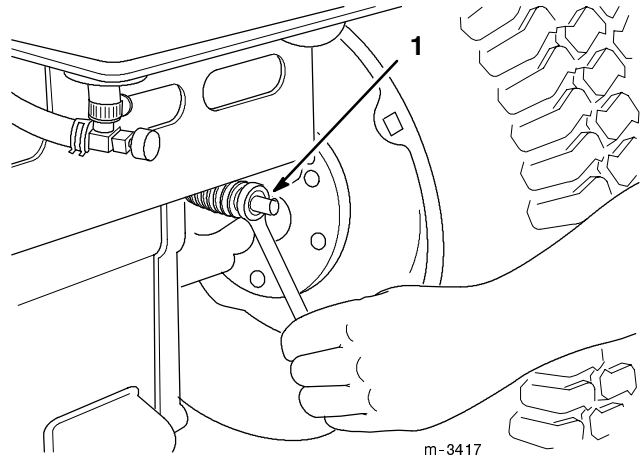

Figure 39

1. Brake adjustment nut

**IMPORTANT: Do not overtighten the adjustment nut.**

**IMPORTANT: With the parking brake released, the rear wheels must rotate freely when you push the tractor. If brake action and free wheel rotation cannot be achieved, contact your Authorized Service Dealer immediately.**

## Fuel Tank

### Draining The Fuel Tank

#### DANGER

##### POTENTIAL HAZARD

- In certain conditions gasoline is extremely flammable and highly explosive.

##### WHAT CAN HAPPEN

- A fire or explosion from gasoline can burn you, others, and cause property damage.

##### HOW TO AVOID THE HAZARD

- Drain gasoline from the fuel tank when the engine is cold. Do this outdoors in an open area. Wipe up any gasoline that spills.
- Never drain gasoline near an open flame or where gasoline fumes may be ignited by a spark.
- Never smoke a cigarette, cigar or pipe near the tractor.

1. Park the machine on a level surface to assure the fuel tank drains completely. Then disengage the power take off (PTO), set the parking brake, lower the attachment lift, and turn the ignition key to "STOP" to stop the engine. Remove the ignition key.
2. Close the fuel shut-off valve at the fuel tank (Fig. 40 & 41).

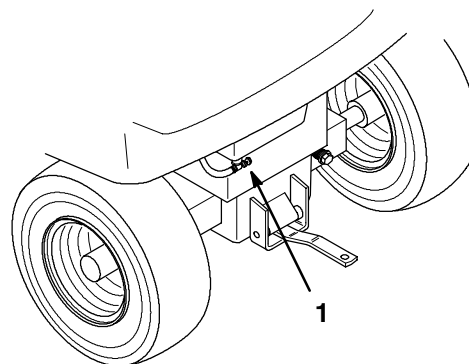

m-3263

**Figure 40**

1. Fuel shut-off valve

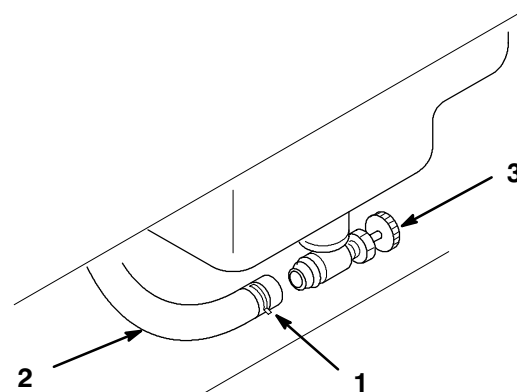

m-2487

**Figure 41**

1. Hose clamp
2. Fuel line
3. Fuel shut-off valve

3. Loosen the hose clamp and slide it up the fuel line away from the fuel shut-off valve (Fig. 41).
4. Pull the fuel line off the fuel shut-off valve (Fig. 41). Some fuel will flow out from the hose as it is disconnected from the valve. Attach a 5/16 ID hose to the valve to help drain the fuel into the container. Open the valve and allow gasoline to drain into a gas can or drain pan.

**IMPORTANT: Do not turn or unscrew the fuel shut-off valve.**

5. Install the fuel line onto the fuel shut-off valve. Slide the hose clamp close to the valve to secure the fuel line (Fig. 41). The fuel shut-off valve should normally be left open, except for service on the fuel system or when the tractor is transported on a trailer.

## Fuel Filter

### Service Interval/Specification

Replace fuel filter after every 100 operating hours.

### Replacing the Fuel Filter

1. Disengage the power take off (PTO), set the parking brake, lower the attachment lift, and turn the ignition key to "STOP" to stop the engine. Remove the ignition key.
2. Close the fuel shut-off valve at the fuel tank (Fig. 40 & 41). Open the hood and remove the side panels.
3. Remove the filter mounting bolt and remove the filter (Fig. 42).
4. Squeeze the ends of the hose clamps together and slide away from the filter (Fig. 42). Remove the fuel lines from the filter.

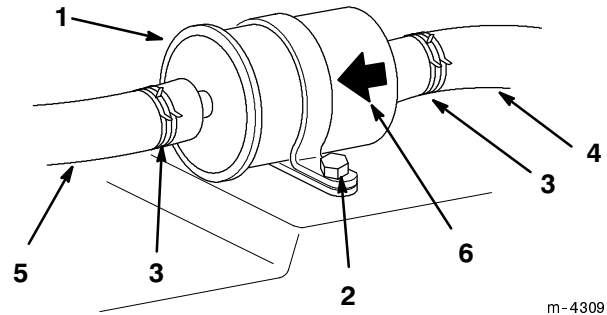

m-4309

**Figure 42**

- |                        |                                  |
|------------------------|----------------------------------|
| 1. Filter              | 5. Fuel line to engine\fuel pump |
| 2. Mounting bolt       | 6. Flow direction arrow          |
| 3. Hose clamp          |                                  |
| 4. Fuel line from tank |                                  |

5. Push fuel lines onto the new filter, and slide hose clamps close to the filter (Fig. 42). Make sure the flow direction arrow points toward the engine/fuel pump. Secure filter to chassis with previously removed mounting bolt (Fig. 42).
6. Open the fuel shut-off valve at the fuel tank (Fig. 40 & 41).
7. Replace the side panels and close the hood.

## Front Wheel Toe-In

### Service Interval/Specification

Maintaining correct front wheel toe-in is important for safety, Smart Turn™ Steering operation, and ease of use. If uneven tire wear, lawn scuffing or hard

steering develop, adjustment may be required. Check the toe-in after every 100 operating hours or once a year, whichever occurs first (Fig. 43).

Maintain the following specification: 1/8-1/4 inch (3.5-6.5 mm) toe-in on the front wheels.

### Measuring Toe-in

1. Disengage the power take off (PTO), set the parking brake, lower the attachment lift, and turn the ignition key to "STOP" to stop the engine. Remove the ignition key.
2. Turn the wheels straight ahead.
3. Push the front of the tires out to remove normal looseness in the linkage.
4. Measure the distance between both of the front tires at spindle level (at the front and rear of the wheels) (Fig. 43).
5. The front measurement should be 1/8" to 1/4" (3 to 6 mm) less than the rear measurement. If adjustment is needed, follow the instructions in Adjusting Toe-In, page 37.

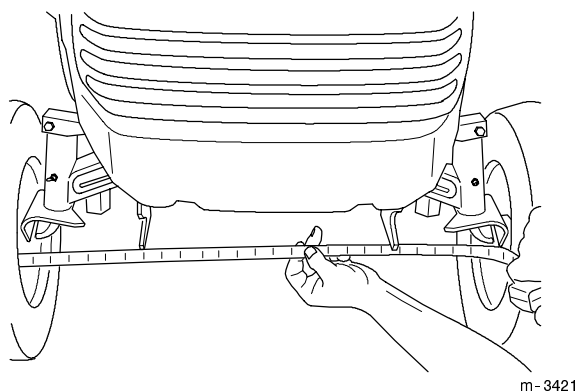

Figure 43

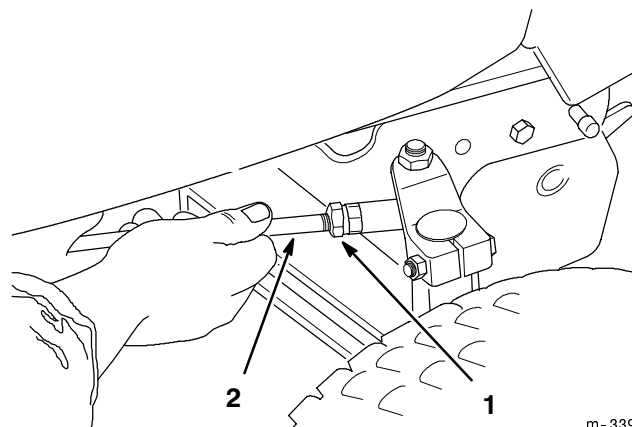

Figure 44

1. Jam nut
2. Steering rod

### Adjusting Toe-In

1. Loosen the jam nuts at the ends of the steering rods (Fig. 44).
2. Rotate both steering rods equal amounts to adjust the toe-in to 1/8" to 1/4" (3 to 6 mm).
3. Hold each tie rod end with one wrench and tighten the jam nut with a second wrench.

**IMPORTANT:** Make sure that the flat surface on the top of the front tie rod ends is parallel to the bottom of the steering arm (Fig. 45).



## Changing Transaxle Oil

Replace the transaxle fluid at 50 hours initially, then every 200 hours thereafter.

**Fluid Type:** SAE 10W-30 Detergent oil (API service SG, SH or above)

### Transaxle Capacity:

Total system capacity: 7.0 qts.

Approximate refill capacity: 4.5 qts.

1. Warm up the transaxle oil by driving the tractor.
2. Park the machine on a level surface to assure the oil drains completely. Then turn off the power take off (PTO), set the parking brake, lower the attachment lift, and turn the ignition key to "STOP" to stop the engine. Remove the ignition key.
3. Place a pan below the transaxle drain. Open the drain by removing the plug (Fig. 48).
 

**Note:** Dispose of the used oil at a certified recycling center.
4. When the oil has drained completely, wipe clean. Apply pipe sealant to the plug and reinstall.

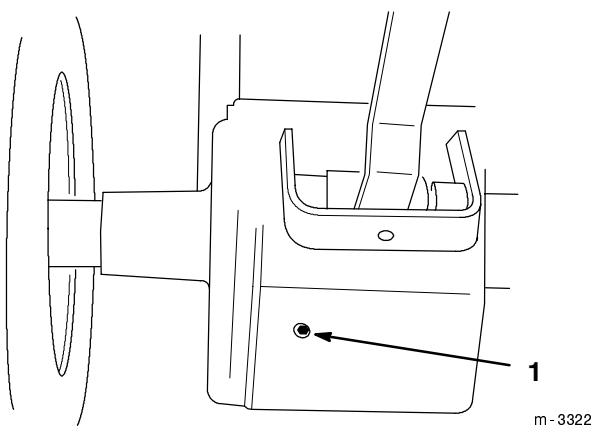

**Figure 48**

1. Transaxle drain plug

5. Change the transaxle filter; refer to Changing the Transaxle Filter, page 39.
6. Slowly pour the specified refill capacity of oil into the filler tube (Fig. 46).
7. Start the engine, let it run for 30 seconds at high idle, and cycle the steering wheel several times to fill the filter and hydraulic lines. Then shut off the engine.
8. Now check the fluid level; refer to Checking Transaxle Fluid Level, page 38. Slowly add additional oil to bring the oil level to the FULL mark on the dipstick.

## Changing the Transaxle Filter

### Service Interval/Specification

Replace the transaxle filter after the first 50 hours; then every 200 hours.

1. Drain the oil from the transaxle; refer to Changing/Draining Transaxle Fluid, page 39.
2. Remove the transaxle filter and wipe the filter adapter (Fig. 49) gasket surface.
3. Apply a thin coat of new oil to the rubber gasket on the replacement filter (Fig. 49).

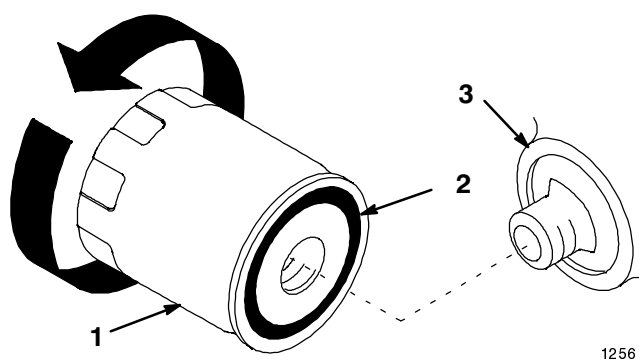

**Figure 49**

1. Transaxle filter
2. Gasket
3. Adapter

1256

4. Install the replacement transaxle filter to the filter adapter. Turn the filter clockwise until the rubber gasket contacts the filter adapter, then tighten the filter an additional 3/4 turn (Fig. 49).
5. Fill the transaxle with the proper type of new oil; refer to Changing/Draining Transaxle Fluid, page 39.

### Cleaning the Power Steering Filter

The power steering filter should be cleaned initially at 50 hours, then at 200-hour intervals thereafter. Please have your Authorized Service Dealer clean the filter.

## Fuse

### Service Interval/Specification

The electrical system is protected by fuses. They require no maintenance. However, if a fuse blows, check the component and circuit for a malfunction or short. To replace a fuse, pull it out of the fuse box (Fig. 50).

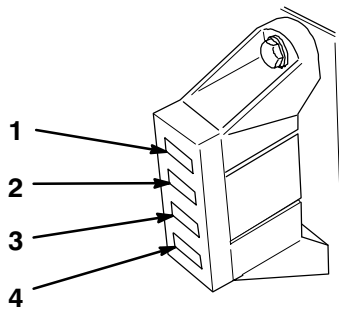

Figure 50

m-3316

1. F1; main-30 amp
2. F2; regulator-25 amp
3. F3; dash, interlock, and cruise control-10 amp
4. F4; headlights and taillights-10 amp

## Headlights

**Specification:** Bulb # 1156 Automotive Type

### Removing the Bulb

1. Disengage the power take off (PTO), set the parking brake, lower the attachment lift, and turn the ignition key to "STOP" to stop the engine. Remove the ignition key.
2. Open the hood. Pull the wire connectors off both bulb holder terminals.
3. Rotate the bulb holder 1/4 turn counterclockwise and remove it from the reflector (Fig. 51).
4. Push and rotate the bulb counterclockwise until it stops (approx. 1/4 turn) and remove the bulb from the bulb holder (Fig. 52).

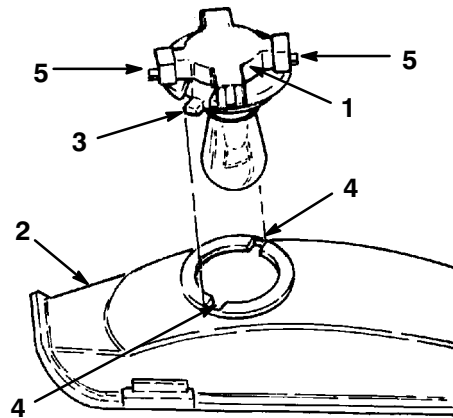
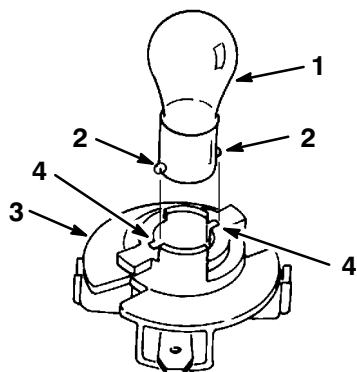

Figure 51

1. Bulb holder
2. Reflector
3. Tabs
4. Slots
5. Terminals

## Installing the Bulb

1. The bulb has metal pins on the side of its base. Align the pins with the slots in the bulb holder and insert the base into the holder (Fig. 52). Push and rotate the bulb clockwise until it stops.



**Figure 52**

- |               |                |
|---------------|----------------|
| 1. Bulb       | 3. Bulb holder |
| 2. Metal pins | 4. Slots       |

2. The bulb holder has two tabs (Fig. 51). Align the tabs with the slots in the reflector, insert the bulb holder into the reflector and rotate it 1/4 turn clockwise until it stops.
3. Push the wire connectors onto the terminals on the bulb holder.

## Taillights

Bulb: GE 194

### Removing the Bulb

1. Disengage the power take off (PTO), set the parking brake, lower the attachment lift, and turn the ignition key to "STOP" to stop the engine. Remove the ignition key.
2. Remove the two screws.
3. Pull the lens out far enough so that you can remove the bulb socket.
4. Pull the bulb from the socket.

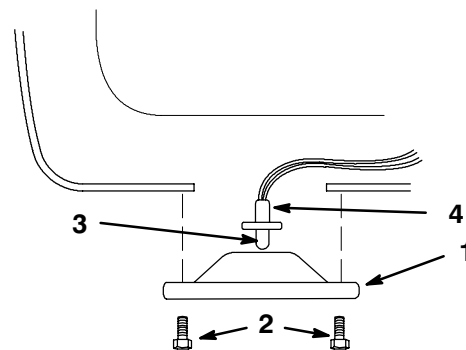

**Figure 53**

- |           |           |
|-----------|-----------|
| 1. Lens   | 3. Bulb   |
| 2. Screws | 4. Socket |

m-3321

### Installing the Bulb

Reverse the bulb removal procedure.

## Battery

### Service Interval/Specification

Check the electrolyte level in the battery every 25 hours. Always keep the battery clean and fully charged. Use a paper towel to clean the battery case. If the battery terminals are corroded, clean them with a solution of four parts water and one part baking soda. Apply a light coating of grease to the battery terminals to prevent corrosion.

Battery size: 12 v, 380 Cold Cranking Amps

### Checking the Electrolyte Level

1. Park the machine on a level surface. Disengage the power take off (PTO), set the parking brake, lower the attachment lift, and turn the ignition key to “STOP” to stop the engine. Remove the ignition key.
2. Remove the front grille by pulling it outward toward you.
3. Remove the battery shield.
4. Open the cell covers to see into the cells. The electrolyte must be up to the lower part of the tube (Fig. 54). Do not allow the electrolyte to get below the plates.
5. If the electrolyte is low, add the required amount of distilled water; refer to Adding Water to the Battery.
6. If the fluid level is correct, press the cell covers onto the battery and replace the battery shield.

**IMPORTANT: Keep the battery shield in place to protect the battery from heat.**

7. Replace the grille.

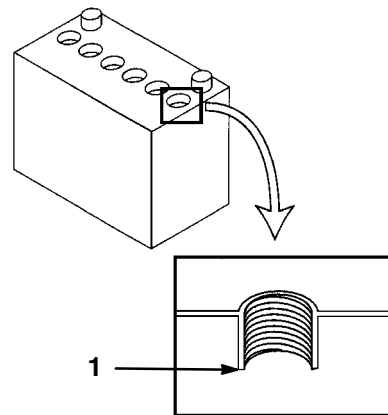

Figure 54

1. Lower part of the battery cell tube

---

### Adding Water to the Battery

**IMPORTANT: Use only distilled water.**

The best time to add distilled water to the battery is just before you operate the machine. This lets the water mix thoroughly with the electrolyte solution.

1. Clean the top of the battery with a paper towel.
2. Lift off the filler caps (Fig. 54).
3. Slowly pour distilled water into each battery cell until the level is up to the lower part of the tube (Fig. 54).

**IMPORTANT: Do not overfill the battery because electrolyte (sulfuric acid) can cause severe corrosion and damage to the chassis.**

4. Press the cell covers onto the battery.
5. Replace the battery shield.

**IMPORTANT: Keep the battery shield in place to protect the battery from heat.**

6. Replace the grille.

## Removing the Battery

1. Disengage the power take off (PTO), set the parking brake, lower the attachment lift, and turn the ignition key to “STOP” to stop the engine. Remove the ignition key.
2. Remove the front grille by pulling it outward toward you.
3. Remove the battery shield (Fig. 55).

**IMPORTANT: Always disconnect the negative (black) cable first.**

4. Disconnect the negative (black) ground cable from the battery post (Fig. 55).
5. Disconnect the positive (red) cable from the battery post (Fig. 55).
6. Remove the battery by lifting it up, then pulling it out (directly toward you) from the tractor.

**IMPORTANT: Always hold the battery vertical to avoid spilling battery acid.**

### **WARNING**

#### **POTENTIAL HAZARD**

- Either the battery terminals or metal tools could short against metal tractor components.
- Incorrect battery cable routing could damage the cables.

#### **WHAT CAN HAPPEN**

- Sparks can cause the battery gasses to explode.
- Damaged cables could short against metal tractor components and cause sparks.

#### **HOW TO AVOID THE HAZARD**

- When removing or installing the battery, do not allow the battery terminals to touch any metal parts of the tractor (below the headlights).
- Always **DISCONNECT** the negative (black) battery cable before disconnecting the positive (red) cable.
- Always **RECONNECT** the positive (red) battery cable before reconnecting the negative (black) cable .
- Do not allow metal tools to short between the battery terminals and metal parts of the tractor.
- Always keep the battery shield and hold-down rods in place to protect and secure the battery.
- Always route battery cables as illustrated.

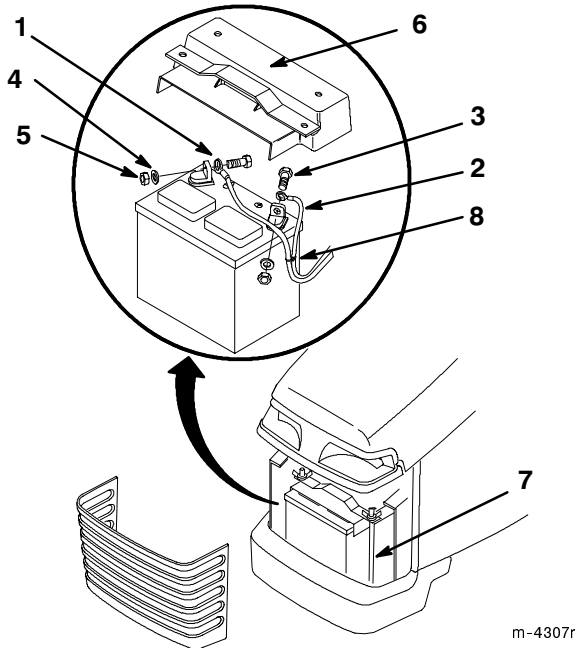

Figure 55

- |                           |                   |
|---------------------------|-------------------|
| 1. Negative cable (black) | 5. Locknut (2)    |
| 2. Positive cable (red)   | 6. Battery shield |
| 3. Bolt (2)               | 7. Hold-down rod  |
| 4. Washer (2)             | 8. Wire tie       |

## Installing the Battery

1. Place the battery onto the chassis (Fig. 55).

**IMPORTANT: Always connect the positive (red) cable first.**

2. Using the bolt, washer and locknut, connect the positive (red) cable to the positive (+) battery post (Fig. 55).
3. Using the bolt, washer and locknut, connect the negative (black) cable to the negative (-) battery post (Fig. 55).
4. Replace the battery shield and secure to the chassis with the hold-down rods and wing nuts.

**IMPORTANT: Keep the battery shield in place to protect the battery from heat.**

5. Replace the grille.

## Charging the Battery

**IMPORTANT: Always keep the battery fully charged (1.260 specific gravity). This is especially important to prevent battery damage when the temperature is below 32°F (0°C).**

1. Remove the battery from the chassis; refer to Removing the Battery, page 43.
2. Check the electrolyte level; refer to Checking the Electrolyte Level, page 42, steps 2-5.
3. Remove the cell covers from the battery and connect a 3- to 4-amp battery charger to the battery posts. Charge the battery at a rate of 4 amperes or less for 4 hours (12 volts). Do not overcharge the battery. Install the cell covers after the battery is fully charged.

### WARNING

#### POTENTIAL HAZARD

- Charging the battery produces gasses.

#### WHAT CAN HAPPEN

- Battery gasses can explode.

#### HOW TO AVOID THE HAZARD

- Keep cigarettes, sparks and flames away from battery.

4. Install the battery in the chassis; refer to Installing the Battery, page 44.

## Cleaning and Storage

1. Disengage the power take off (PTO), set the parking brake, and turn the ignition key to "STOP" to stop the engine. Remove both the ignition and "Key Choice" keys.
2. Remove grass clippings, dirt, and grime from the external parts of the entire machine, especially the engine. Clean dirt and chaff from the outside of the engine's cylinder head fins and blower housing; refer to Check for Debris, page 12.

**IMPORTANT: You can wash the machine with mild detergent and water. DO NOT PRESSURE WASH THE MACHINE. Pressure washing may damage the electrical system or wash away necessary grease at friction points. Avoid excessive use of water, especially near the control panel, lights, engine, and the battery.**

3. Check the brake; refer to Brake, page 33.
4. Service the air cleaner; refer to Air Cleaner, page 26.
5. Grease the chassis; refer to Greasing and Lubrication, page 32.
6. Change the crankcase oil; refer to Engine Oil, page 28.
7. Check the tire pressure; refer to Tire Pressure, page 33.
8. For storage over 30 days, prepare the traction unit as follows.
  - A. Add a petroleum based stabilizer/conditioner to fuel in the tank. Follow mixing instructions from stabilizer manufacturer. (1 oz. per gallon). **Do not use an alcohol based stabilizer (ethanol or methanol).**

**Note:** A fuel stabilizer/conditioner is most effective when mixed with fresh gasoline and used at all times.

  - B. Run the engine to distribute conditioned fuel through the fuel system (5 minutes).
  - C. Stop the engine, allow it to cool and drain the fuel tank; refer to Draining Fuel Tank, page 35.
  - D. Restart the engine and run it until it stops.
  - E. Choke the engine.
  - F. Start and run the engine until it will not start again.

- G. Dispose of fuel properly. Recycle as per local codes.

**IMPORTANT: Do not store stabilizer/conditioned gasoline over 90 days.**

9. Remove the spark plug(s) and check its condition; refer to Spark Plug, page 30. With the spark plug(s) removed from the engine, pour two tablespoons of engine oil into the spark plug hole. Now use the electric starter to crank the engine and distribute the oil inside the cylinder. Install the spark plug(s) and tighten to recommended torque; refer to Spark Plugs, page 30. Do not install the wire on the spark plug(s).
10. Remove the battery from the chassis, check the electrolyte level, and charge it fully; refer to Battery, page 42. Do not connect the battery cables to the battery posts during storage.

**IMPORTANT: The battery must be fully charged to prevent it from freezing and being damaged at temperatures below 32°F (0°C). A fully charged battery maintains its charge for about 50 days at temperatures lower than 40°F (4°C). If the temperatures will be above 40°F (4°C), check the water level in the battery and charge it every 30 days.**

11. Check and tighten all bolts, nuts, and screws. Repair or replace any part that is damaged or defective.
12. Paint all scratched or bare metal surfaces. Paint is available from your Authorized Service Dealer.
13. Store the machine in a clean, dry garage or storage area. Remove both the ignition and “Key Choice” keys and put them in a safe place out of the reach of children. Cover the machine to protect it and keep it clean.



# Wiring Diagram

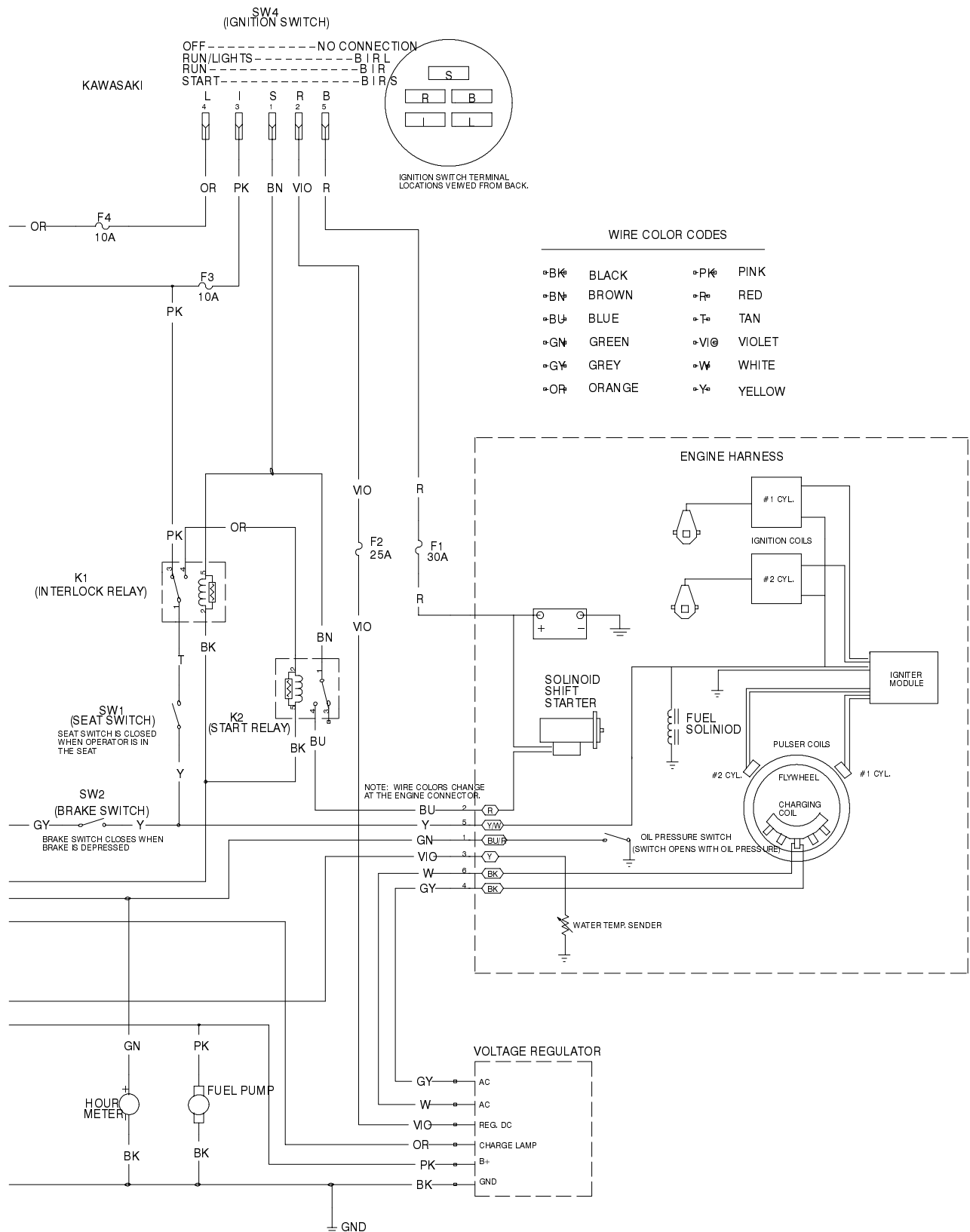

# Troubleshooting

PROBLEM	POSSIBLE CAUSES	CORRECTIVE ACTION
The starter does not crank.	<ol style="list-style-type: none"> <li>1. The PTO is ON.</li> <li>2. The brake is not depressed or the parking brake is not on.</li> <li>3. The operator is not seated.</li> <li>4. The electrical connections are corroded or loose.</li> <li>5. A fuse is blown or loose.</li> <li>6. The relay or switch is defective.</li> <li>7. The battery is discharged.</li> <li>8. The safety interlock system is malfunctioning.</li> <li>9. A faulty starter or starter solenoid.</li> <li>10. Seized internal engine components.</li> </ol>	<ol style="list-style-type: none"> <li>1. Move the PTO to OFF.</li> <li>2. Set the parking brake.</li> <li>3. Sit on the seat.</li> <li>4. Check the electrical connections for good contact.</li> <li>5. Correct or replace the fuse.</li> <li>6. Contact your Authorized Service Dealer.</li> <li>7. Charge the battery or replace it.</li> <li>8. Contact your Authorized Service Dealer.</li> <li>9. Contact your Authorized Service Dealer.</li> <li>10. Contact your Authorized Service Dealer.</li> </ol>
The engine cranks, but will not start.	<ol style="list-style-type: none"> <li>1. Incorrect starting procedure.</li> <li>2. The fuel tank is empty.</li> <li>3. The fuel shut-off valve is closed.</li> <li>4. Dirt, water or stale fuel is in the fuel system.</li> <li>5. Clogged fuel line.</li> <li>6. The spark plug lead is disconnected.</li> <li>7. The kill relay is not energized.</li> <li>8. A spark plug is faulty.</li> <li>9. The ignition module is faulty.</li> </ol>	<ol style="list-style-type: none"> <li>1. Refer to Starting and Stopping the Engine, page 14.</li> <li>2. Fill with fresh fuel.</li> <li>3. Open the fuel shut-off valve.</li> <li>4. Drain and flush the fuel system; add fresh fuel.</li> <li>5. Clean or replace.</li> <li>6. Reconnect the spark plug.</li> <li>7. Contact your Authorized Service Dealer.</li> <li>8. Replace the spark plug.</li> <li>9. Contact your Authorized Service Dealer.</li> </ol>

PROBLEM	POSSIBLE CAUSES	CORRECTIVE ACTION
The engine starts, but does not keep running	<ol style="list-style-type: none"> <li>1. Misadjusted or faulty choke or throttle control cable.</li> <li>2. The fuel tank vent is restricted.</li> <li>3. Dirt or water in the fuel system.</li> <li>4. The fuel filter is clogged.</li> <li>5. The fuel pump is faulty.</li> <li>6. The carburetor is faulty.</li> <li>7. Loose wires or poor connections.</li> <li>8. The cylinder head gasket is faulty.</li> <li>9. A fuse is blown or loose.</li> </ol>	<ol style="list-style-type: none"> <li>1. Contact your Authorized Service Dealer.</li> <li>2. Contact your Authorized Service Dealer.</li> <li>3. Drain and flush the fuel system; add fresh fuel.</li> <li>4. Replace the fuel filter.</li> <li>5. Contact your Authorized Service Dealer.</li> <li>6. Contact your Authorized Service Dealer.</li> <li>7. Check and tighten wire connections.</li> <li>8. Contact your Authorized Service Dealer.</li> <li>9. Correct or replace the fuse.</li> </ol>
The engine runs, but knocks or misses.	<ol style="list-style-type: none"> <li>1. Dirt, water or stale fuel is in the fuel system.</li> <li>2. A spark plug lead is loose.</li> <li>3. A spark plug is faulty.</li> <li>4. Loose wires or poor connections.</li> <li>5. Engine overheating.</li> </ol>	<ol style="list-style-type: none"> <li>1. Drain and flush the fuel system; add fresh fuel.</li> <li>2. Reconnect the spark plug lead.</li> <li>3. Replace the spark plug.</li> <li>4. Check and tighten wire connections.</li> <li>5. See ENGINE OVERHEATS.</li> </ol>
The engine will not idle.	<ol style="list-style-type: none"> <li>1. The fuel tank vent is restricted.</li> <li>2. Dirt, water or stale fuel is in the fuel system.</li> <li>3. A spark plug is faulty.</li> <li>4. Carburetor idle passages are plugged.</li> <li>5. The idle speed adjusting screw is incorrectly set.</li> <li>6. The fuel pump is faulty.</li> <li>7. Low compression.</li> <li>8. The air cleaner element is dirty.</li> </ol>	<ol style="list-style-type: none"> <li>1. Contact your Authorized Service Dealer.</li> <li>2. Drain and flush the fuel system; add fresh fuel.</li> <li>3. Replace the spark plug.</li> <li>4. Contact your Authorized Service Dealer.</li> <li>5. Contact your Authorized Service Dealer.</li> <li>6. Contact your Authorized Service Dealer.</li> <li>7. Contact your Authorized Service Dealer.</li> <li>8. Clean or replace.</li> </ol>

PROBLEM	POSSIBLE CAUSES	CORRECTIVE ACTION
The engine overheats.	<ol style="list-style-type: none"> <li>1. More coolant is needed.</li> <li>2. (3) air intake screens are dirty.</li> <li>3. Restricted air flow into the engine.</li> <li>4. Radiator fins are dirty.</li> <li>5. The crankcase oil level is incorrect.</li> <li>6. The fuel mixture is lean.</li> <li>7. Excessive loading.</li> </ol>	<ol style="list-style-type: none"> <li>1. Check and add coolant.</li> <li>2. Clean with every use.</li> <li>3. Inspect and clean the radiator screen with every use.</li> <li>4. Clean the radiator fins.</li> <li>5. Fill or drain to the full mark.</li> <li>6. Contact your Authorized Service Dealer.</li> <li>7. Reduce load; use lower ground speed.</li> </ol>
The engine loses power.	<ol style="list-style-type: none"> <li>1. The crankcase oil level is incorrect.</li> <li>2. The air cleaner element is dirty.</li> <li>3. Dirt, water or stale fuel is in the fuel system.</li> <li>4. The engine is overheated.</li> <li>5. A spark plug is faulty.</li> <li>6. Low compression.</li> <li>7. The vent hole in the fuel tank vent fitting is plugged.</li> <li>8. The engine load is excessive.</li> </ol>	<ol style="list-style-type: none"> <li>1. Fill or drain to the full mark.</li> <li>2. Clean or replace.</li> <li>3. Drain and flush the fuel system; add fresh fuel.</li> <li>4. See ENGINE OVERHEATS.</li> <li>5. Replace the spark plug.</li> <li>6. Contact your Authorized Service Dealer.</li> <li>7. Contact your Authorized Service Dealer.</li> <li>8. Reduce ground speed.</li> </ol>
The tractor will not operate in either direction because the engine bogs down or stalls.	<ol style="list-style-type: none"> <li>1. The brake is sticking.</li> </ol>	<ol style="list-style-type: none"> <li>1. Contact your Authorized Service Dealer.</li> </ol>
The tractor goes forward only at partial speed and is slow or does not operate in reverse.	<ol style="list-style-type: none"> <li>1. The cruise control was engaged when the traction pedal was in neutral.</li> <li>2. The engine is running at partial speed.</li> <li>3. The linkage is out of adjustment.</li> <li>4. There is internal hydro wear.</li> </ol>	<ol style="list-style-type: none"> <li>1. Turn the cruise control off.</li> <li>2. Move the throttle to "FAST."</li> <li>3. Contact your Authorized Service Dealer.</li> <li>4. Contact your Authorized Service Dealer.</li> </ol>

PROBLEM	POSSIBLE CAUSES	CORRECTIVE ACTION
<p>The tractor will not operate in either direction.</p>	<ol style="list-style-type: none"> <li>1. The High-Low range lever is in "N."</li> <li>2. The transmission oil is low.</li> <li>3. The transmission is faulty.</li> <li>4. The control linkage needs adjustment or replacement.</li> <li>5. The parking brake was not released or the parking brake is not releasing.</li> <li>6. The drive shaft or wheel hub key has been damaged.</li> <li>7. The power steering filter is dirty.</li> </ol>	<ol style="list-style-type: none"> <li>1. Move the High-Low range lever to "L" or "H."</li> <li>2. Fill to the full "F" mark on the transmission oil dipstick when the transmission is cold.</li> <li>3. Contact your Authorized Service Dealer.</li> <li>4. Contact your Authorized Service Dealer.</li> <li>5. Release the parking brake or check the linkage.</li> <li>6. Contact your Authorized Service Dealer.</li> <li>7. Contact your Authorized Service Dealer.</li> </ol>
<p>The tractor operates erratically.</p>	<ol style="list-style-type: none"> <li>1. The transmission oil level is low.</li> <li>2. The transmission control linkage needs adjustment or replacement.</li> <li>3. The transmission is faulty.</li> </ol>	<ol style="list-style-type: none"> <li>1. Fill to the full "F" mark on the transmission oil dipstick when the transmission is cold.</li> <li>2. Contact your Authorized Service Dealer.</li> <li>3. Contact your Authorized Service Dealer.</li> </ol>
<p>The tractor operates in both directions, but with a loss of power. This condition becomes worse as the transmission becomes hot.</p>	<ol style="list-style-type: none"> <li>1. The transmission oil level is low.</li> <li>2. The transmission shows signs of overheating or water contamination.</li> <li>3. The cooling fan and/or transmission cooling fins are faulty or dirty.</li> <li>4. The engine is not operating at full throttle.</li> <li>5. The power steering filter is dirty.</li> </ol>	<ol style="list-style-type: none"> <li>1. Fill to the full "F" mark on the transmission oil dipstick when the transmission is cold.</li> <li>2. Replace the transmission oil and filter.</li> <li>3. Clean the transmission and/or replace the fan (contact your Authorized Service Dealer).</li> <li>4. Increase the engine speed to full throttle.</li> <li>5. Contact your Authorized Service Dealer.</li> </ol>
<p>The front wheels do not turn with the steering wheel.</p>	<ol style="list-style-type: none"> <li>1. Air in the hydraulic system.</li> </ol>	<ol style="list-style-type: none"> <li>1. With the engine running, operate the lift and turn the steering wheel back and forth several times.</li> </ol>
<p>The steering is noisy.</p>	<ol style="list-style-type: none"> <li>1. The power steering filter is dirty.</li> </ol>	<ol style="list-style-type: none"> <li>1. Contact your Authorized Service Dealer.</li> </ol>

PROBLEM	POSSIBLE CAUSES	CORRECTIVE ACTION
Abnormal vibration or noise.	<ol style="list-style-type: none"> <li>1. The engine mounting bolts are loose.</li> <li>2. The idler pulley or cutter deck blade is loose.</li> <li>3. The transaxle cooling fan is loose.</li> <li>4. There is a problem with the electric clutch</li> </ol>	<ol style="list-style-type: none"> <li>1. Tighten the engine mounting bolts.</li> <li>2. Tighten the appropriate pulley.</li> <li>3. Contact your Authorized Service Dealer.</li> <li>4. Contact your Authorized Service Dealer.</li> </ol>
PTO (cutter deck) belt comes off of pulleys, slips, or fails.	<ol style="list-style-type: none"> <li>1. Belt tension is incorrect.</li> <li>2. Mower level is incorrect</li> <li>3. Blade slope in transport is incorrect.</li> <li>4. Cutter deck belt guide is loose or incorrectly adjusted.</li> <li>5. Belt is worn or damaged.</li> <li>6. Pulley is damaged.</li> <li>7. Engine is not at full throttle.</li> <li>8. PTO is being engaged when cutter deck is in tall uncut grass or weeds.</li> <li>9. Cutter deck is overloaded because mulching or bagging requires more power.</li> <li>10. Cutter deck is overloaded because too much grass is being cut at a time.</li> <li>11. Cutter deck is overloaded because deck is clogged with grass clippings.</li> <li>12. Cutter deck is overloaded because tractor is mowing too fast for conditions.</li> </ol>	<ol style="list-style-type: none"> <li>1. See cutter deck or attachment manual.</li> <li>2. See cutter deck manual.</li> <li>3. See cutter deck manual.</li> <li>4. Adjust and tighten belt guide.</li> <li>5. See cutter deck or attachment manual.</li> <li>6. Contact authorized dealer.</li> <li>7. Always operate engine powered attachments at full throttle.</li> <li>8. Engage PTO only in shorter or previously cut grass.</li> <li>9. Reduce ground speed when mulching or bagging.</li> <li>10. Cut tall grass and weeds with mower in its highest position, making a second pass cutting at height desired.</li> <li>11. Clean cutter deck.</li> <li>12. Reduce ground speed.</li> </ol>





Consumer  
Riding  
Products

## The Toro Total Coverage Guarantee

A Two-Year Full Warranty  
(Limited Warranty for Commercial Use)

### Conditions and Products Covered

The Toro Company and its affiliate, Toro Warranty Company, pursuant to an agreement between them, jointly promise to repair any Toro Product used for normal residential purposes\* if defective in materials or workmanship. The following time periods apply from the date of purchase:

<u>Products</u>	<u>Warranty Period</u>
• All Products	2 year full warranty
• 300 and 5xi Series Tractors:	
Chassis	5 year full warranty
Front Axle	5 year full warranty
Drive Shaft (5xi Series Only)	5 year full warranty
• All Batteries	1 year full warranty

This warranty covers both the cost of parts and labor, and transportation within a fifteen mile radius of the servicing dealer.

This warranty applies to all consumer riding products and their attachments.

\* Normal residential purposes means use of the product on the same lot as your home. Use at more than one location is considered commercial use, and the commercial use warranty would apply.

### Limited Warranty for Commercial Use

Toro Consumer Products and attachments used for commercial, institutional, or rental use are warranted against defects in materials or workmanship for the following time periods from the date of purchase:

<u>Products</u>	<u>Warranty Period</u>
• All Products	90 day limited warranty
• 300 and 5xi Series Tractors:	
Chassis	1 year limited warranty
Liquid Cooled Gas Engines	1 year limited warranty
Air Cooled Gas and Diesel Engines	2 year limited warranty

### Instructions for Obtaining Warranty Service

Should you feel your Toro Product contains a defect in materials or workmanship, contact the retailer who sold you the product or any Authorized Service Dealer or Master Service Dealer. The Yellow Pages of your telephone directory is a good reference source. The dealer will either arrange service at his/her dealership or recommend another Authorized Service Dealer who may be more convenient. You may need proof of purchase (copy of registration card, sales receipt, etc.) for warranty validation.

### Countries Other than the United States or Canada

Customers who have purchased Toro products exported from the United States or Canada should contact their Toro Distributor (Dealer) to obtain guarantee policies for your country, province, or state. If for any reason you are dissatisfied with your Distributor's service or have difficulty obtaining guarantee information, contact the Toro importer. If all other remedies fail, you may contact us at Toro Warranty Company.

If for any reason you are dissatisfied with the Service Dealer's analysis of the defect in materials or workmanship or if you need a referral to a Toro Service Dealer, please feel free to contact us at:

Customer Service Department  
Toro Warranty Company  
8111 Lyndale Avenue South  
Bloomington, MN 55420-1196  
612-888-8801  
800-348-2424

### Owner Responsibilities

You must maintain your Toro Product by following the maintenance procedures described in the operator's manual. Such routine maintenance, whether performed by a dealer or by you, is at your expense.

### Items and Conditions Not Covered

There is no other express warranty except for special emission system coverage on some products. This express warranty does not cover:

- Cost of regular maintenance service or parts, such as filters, fuel, lubricants, tune-up parts, blade sharpening, brake and clutch adjustments.
- Any product or part which has been altered or misused or required replacement or repair due to normal wear, accidents, or lack of proper maintenance.
- Repairs necessary due to improper fuel, contaminants in the fuel system, or failure to properly prepare the fuel system prior to any period of non-use over three months.
- Pickup and delivery charges for distances beyond a fifteen mile radius from an Authorized Toro Service Dealer.

All repairs covered by this warranty must be performed by an Authorized Toro Service Dealer using Toro approved replacement parts.

### General Conditions

Repair by an Authorized Toro Service Dealer is your sole remedy under this warranty.

Neither The Toro Company nor Toro Warranty Company is liable for indirect, incidental or consequential damages in connection with the use of the Toro Products covered by this warranty, including any cost or expense of providing substitute equipment or service during reasonable periods of malfunction or non-use pending completion of repairs under this warranty. Some states do not allow exclusions of incidental or consequential damages, or limitations on how long an implied warranty lasts, so the above exclusions and limitations may not apply to you.

This warranty gives you specific legal rights, and you may also have other rights which vary from state to state.