

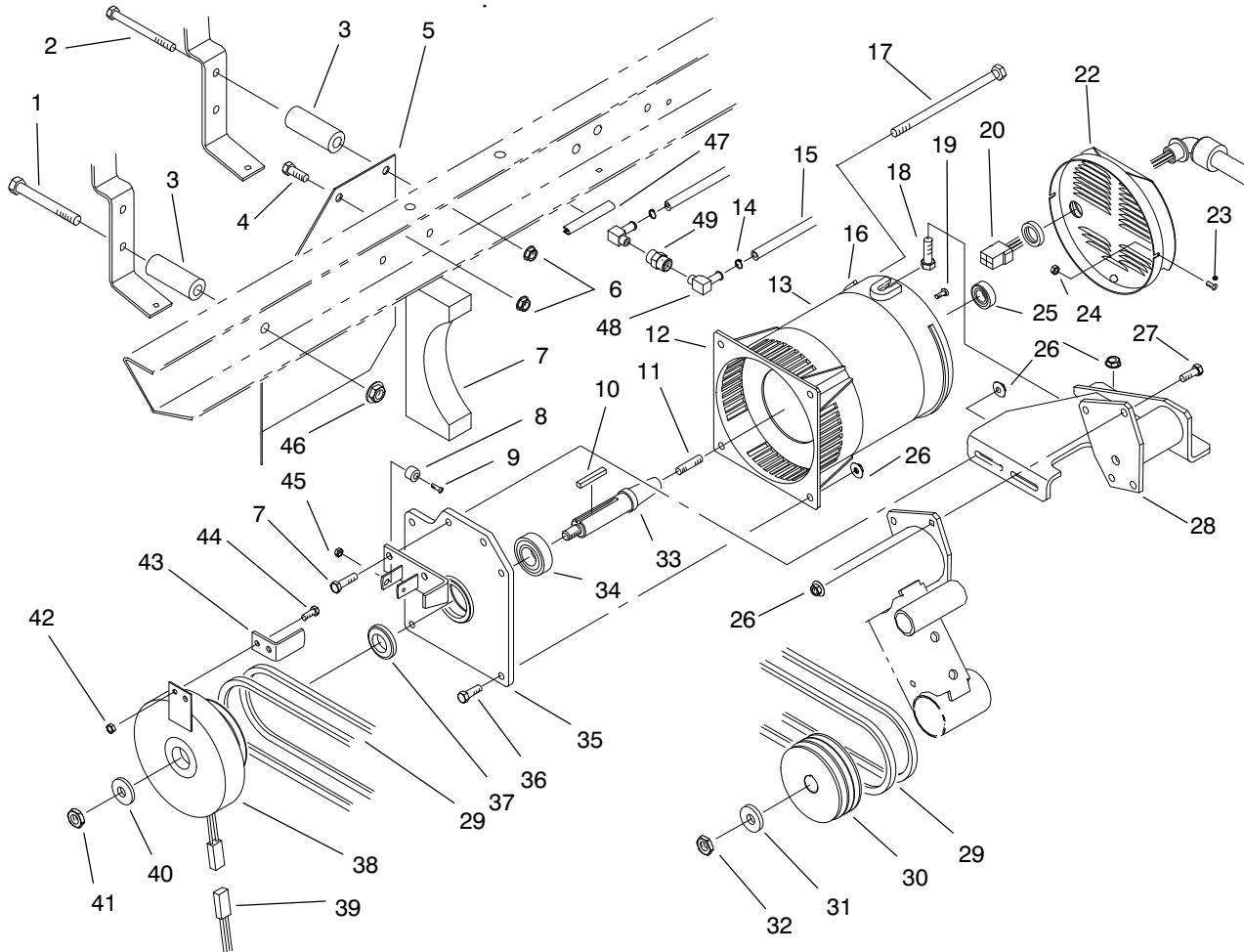

MODEL NO. 07403-80001 & UP

PARTS
CATALOG

120 Volt AC Generator Workman®



T-1960

Generator Assembly

Ref. No.	Part No.	Description	No. Used
1	325-17	Screw - Cap Hex. Hd.	2
2	323-16	Screw - Cap Hex. Hd.	2
3	92-2855	Tube - Spacer, Fuel Tank	4
4	323-4	Screw - Cap Hex. Hd.	4
5	92-2856	Shield - Generator	1
6	3290-357	Nut - Flange	4
7	92-2857	Baffle - Generator	1
8	66-2910	Bumper - Rubber	2
9	3250-39	Screw - Pan Phil. Hd.	2
10	7-0238	Key - Square	1
11	92-2840	Screw - Rotor	1
12	93-3944	Bracket - Fan	1
13	93-3943	Cover - Stator	1
14	92-2379	Clamp - Hose	2
15	93-3949	Tube - Fuel	1
16	92-2899	Bracket - Bearing, Rear	1

Ref. No.	Part No.	Description	No. Used
17	92-2898	Bolt - Stator	4
18	322-5	Screw - Cap Hex. Hd.	1
19	93-3942	Screw - Ground	1
20	92-2887	Connector	1
22	92-2847	Cover W.A. - Rear	1
23	93-7654	Screw	2
24	93-7655	Nut	2
25	93-3945	Bearing	1
26	32128-20	Nut - Lock, Flange	12
27	322-6	Screw - Cap Hex. Hd.	6
28	92-2833	Mount W.A. - Generator	1
29	92-2845	Belt Set - Generator	1
30	92-2846	Pulley - Drive, Fan	1
31	3256-28	Washer - Flat	1
32	3296-15	Nut - Hex.	1
33	100-4515	Shaft - Generator	1

3323-568

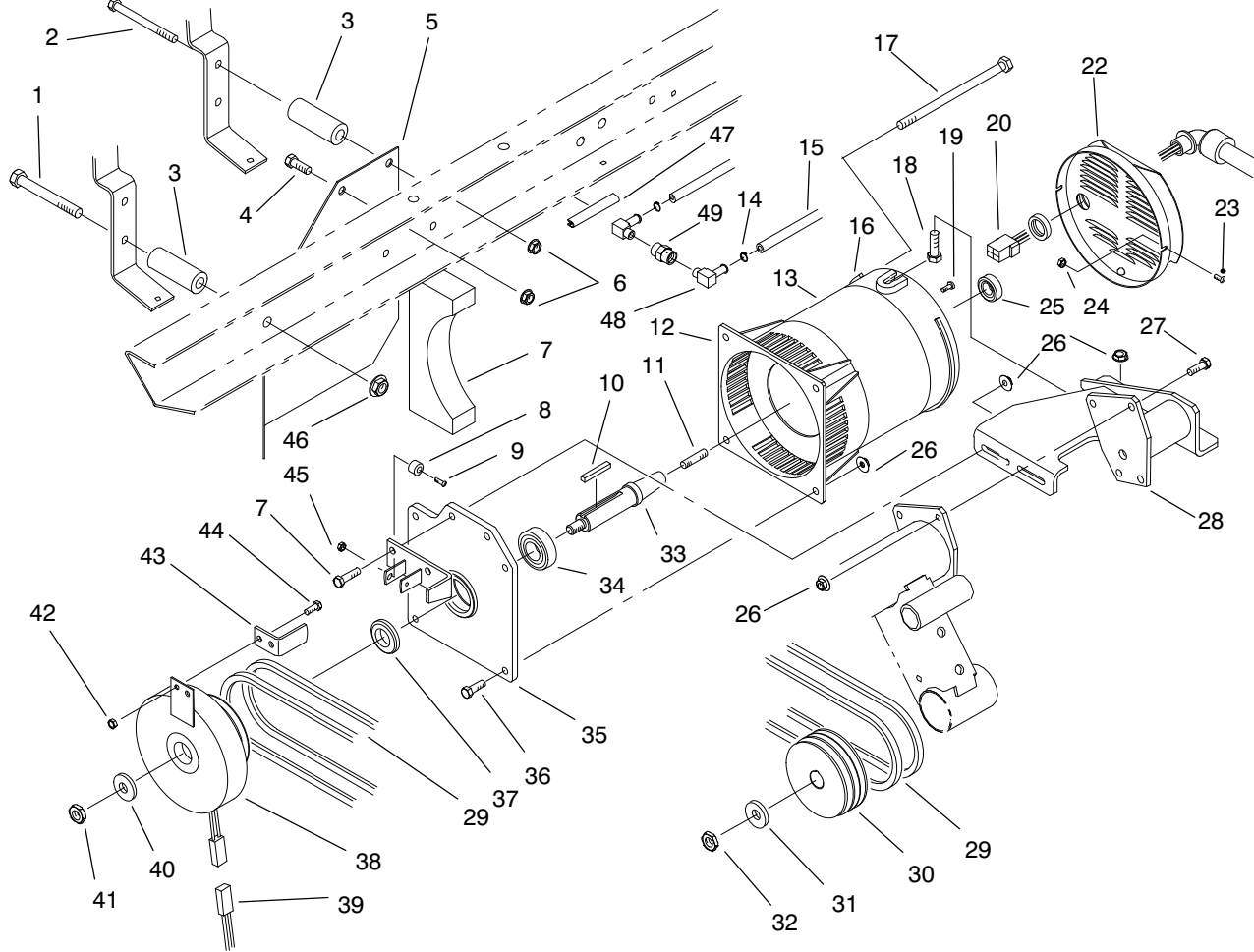

T-1960

Generator Assembly (Continued)

Ref. No.	Part No.	Description	No. Used
34	70-9240	Bearing	1
35	92-2837	Mount - Bearing	1
36	322-5	Screw - Cap Hex. Hd.	4
37	92-2842	Spacer - Generator	1
38	92-2627	Assembly - Clutch, Elec.	1
39	92-2853	Harness - Wire	1
40	92-2651	Washer	1
41	3296-45	Nut - Lock	1
42	3296-56	Nut - Lock	2
43	92-2843	Tab - Bumper	1

Ref. No.	Part No.	Description	No. Used
44	321-4	Screw - Cap Hex. Hd.	2
45	3296-9	Nut - Lock	2
46	3218-23	Nut - Lock, Flange	2
47	43-4300	Trim - Frame, Rear	1
48	93-3948	Fitting - Fuel	2
49	93-3947	Fitting - Coupler	1
*	100-4514	Assembly - Generator (Incl. Ref. #11-13, 16-17, 19, 25, 26, & 33-36)	1
*	3290-379	Tie - Cable	1

*Not Illustrated

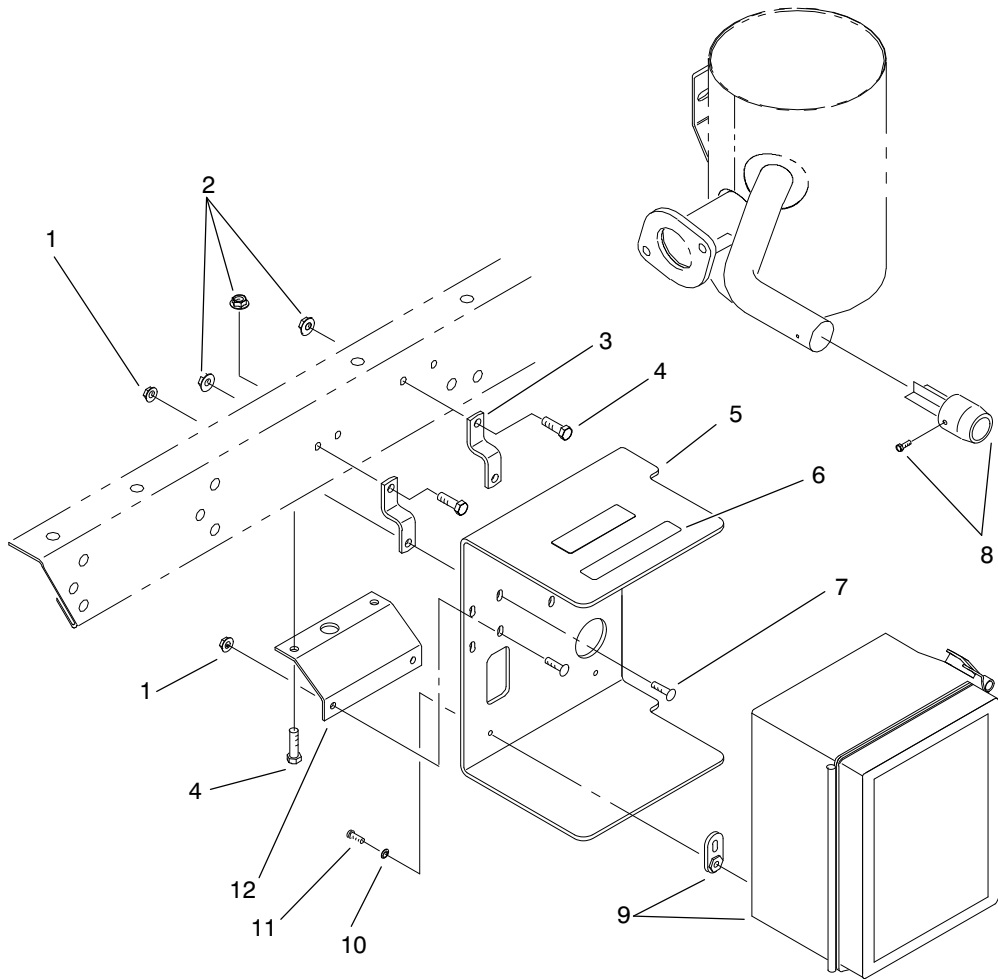

T-1961

Control Box Assembly

Ref. No.	Part No.	Description	No. Used
1	32128-32	Nut - Lock, Flange	4
2	32128-20	Nut - Lock, Flange	4
3	92-2860	Tab - Mount	2
4	322-3	Screw - Cap Hex. Hd.	4
5	92-2895	Bracket - Box, Control (Incl. Ref. #6)	1
6	36-3400	Decal - Warning	1

Ref. No.	Part No.	Description	No. Used
7	3229-2	Bolt - Carriage	4
8	75-6880	Arrestor - Spark	1
9	92-2862	Assembly - Box, Control	1
10	3254-1	Washer - Lock, Int. Tooth	4
11	3250-31	Screw - Pan Phil. Hd.	4
12	92-2859	Bracket - Mount	1

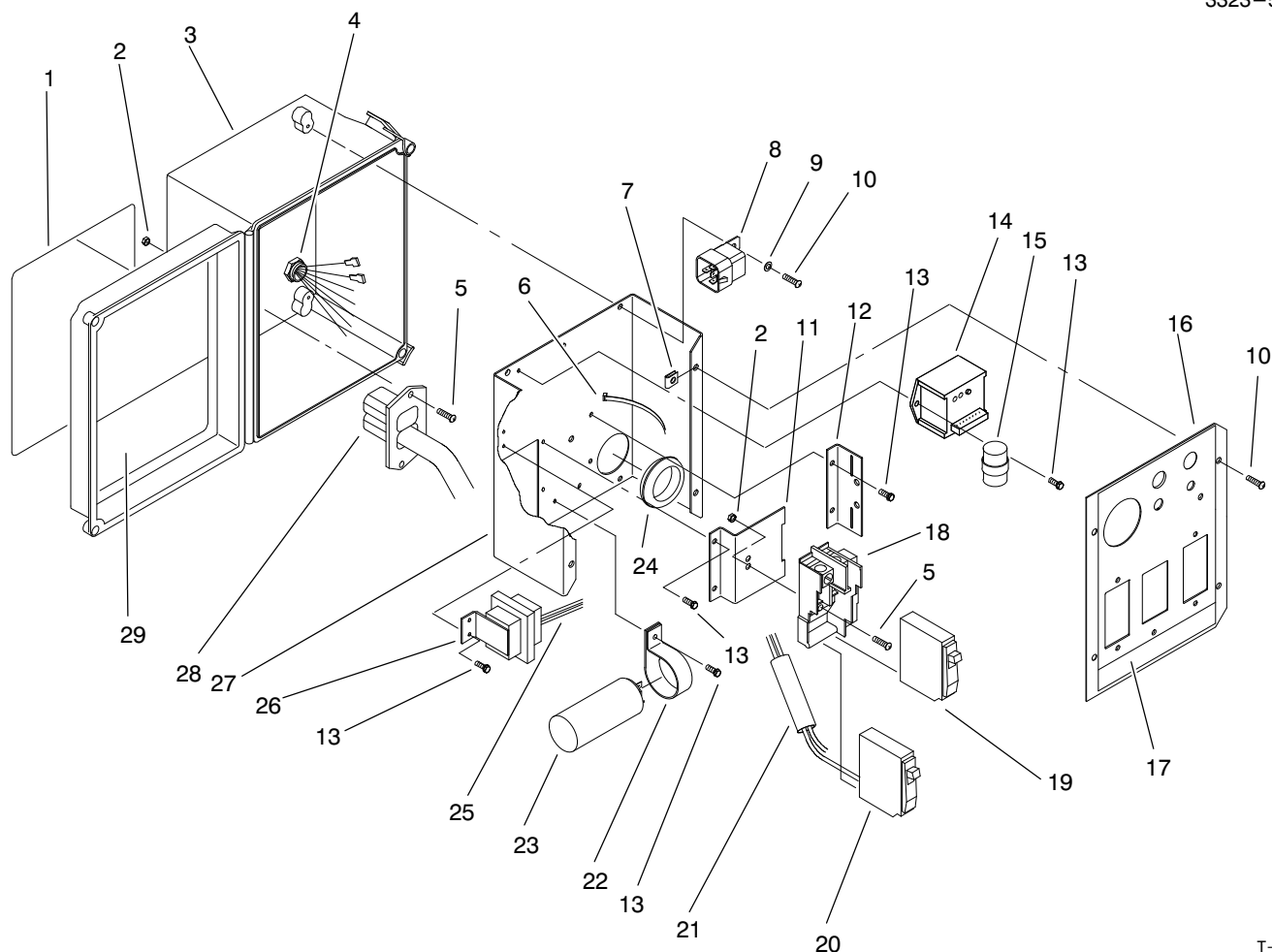

T-1965

Control Box Assembly (Continued)

Ref. No.	Part No.	Description	No. Used	Ref. No.	Part No.	Description	No. Used
1	93-3938	Decal - Generator	1	16	92-2897	Panel - Box, Control (Incl. Ref. #17)	1
2	32149-7	Nut - Keps	3	17	93-3937	Decal - Panel, Control	1
3	92-2896	Box - Control (Incl. Ref. #1 & 29)	1	18	92-2882	Base - Mounting	1
4	92-2852	Harness - Wire, Generator	1	19	92-2880	Circuit Breaker - 15 Amp.	1
5	3250-13	Screw - Pan Head	3	20	92-2881	Circuit Breaker - 20 Amp.	1
6	3290-379	Tie - Cable	5	21	92-2872	Harness - Wire, Box AC	1
7	3290-191	Nut - Speed	4	22	92-2874	Clamp - Tube	2
8	63-7590	Relay - S.P.D.T.	1	23	92-2873	Capacitor	1
9	3254-1	Washer - Lock, Int. Tooth	4	24	237-91	Grommet	1
10	3250-12	Screw - Pan Phil Hd.	12	25	92-2851	Harness - Wire, Transformer	1
11	92-2865	Bracket - Breaker, Circuit	1	26	92-2883	Transformer	1
12	92-2866	Bracket - Breaker	1	27	92-2864	Bracket - Box, Control	1
13	32144-42	Screw - Hex. Hd.	10	28	92-2879	Harness - Wire, Box D.C.	1
14	92-2877	Switch - Frequency	1	29	93-3939	Decal - Operation	1
15	92-2876	Time Delay	1				

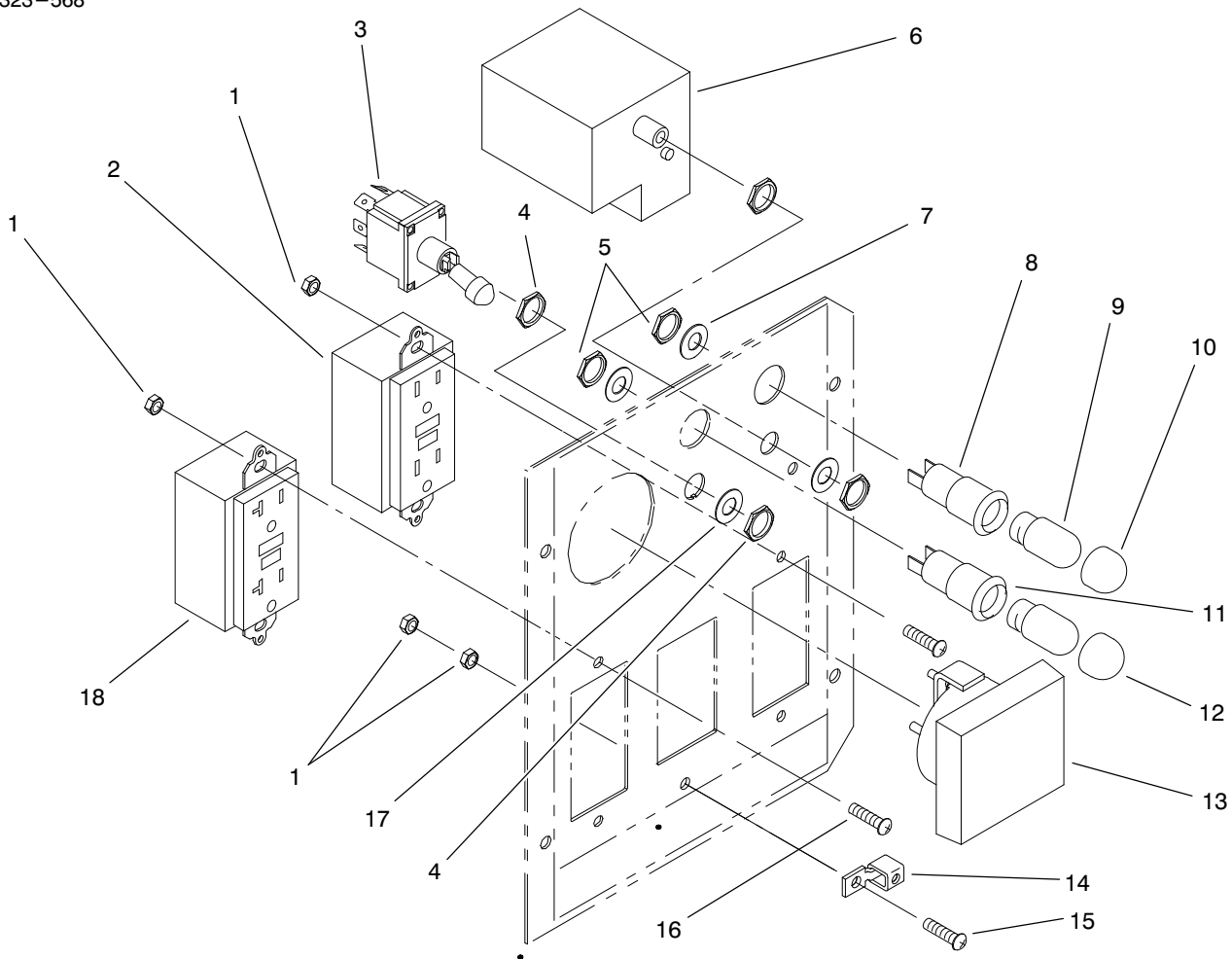

T-1968

Control Box Assembly (Continued)

Ref. No.	Part No.	Description	No. Used
1	32149-7	Nut - Keps	6
2	92-2871	Outlet - 120 V. GFI 15 A	1
3	85-4980	Switch - PTO (Incl. Ref. #4 & 16)	1
4	3218-19	Nut - Hex.	2
5	218-535	Nut - Hex.	2
6	92-2878	Switch - Tattletale	1
7	218-536	Washer - Lock	2
8	44-2212	Assembly - Light, Warning (Incl. Ref. #5, 7, 9, & 10,)	1
9		Bulb - Indicator Light (#1891)	2

Ref. No.	Part No.	Description	No. Used
10	218-562	Lens - Indicator Light (Amber)	1
11	44-2210	Light - Warning (Incl. Ref. #5, 7, 9 & 12)	1
12	218-533	Lens - Indicator Light (Red)	1
13	92-2869	Voltmeter	1
14	92-2875	Lug - Ground	1
15	3250-13	Screw - Pan Head	1
16	3250-12	Screw - Pan Phil. Hd.	11
17	3254-20	Washer - Lock	1
18	92-2870	Outlet - 120 V. GFI 20A	1

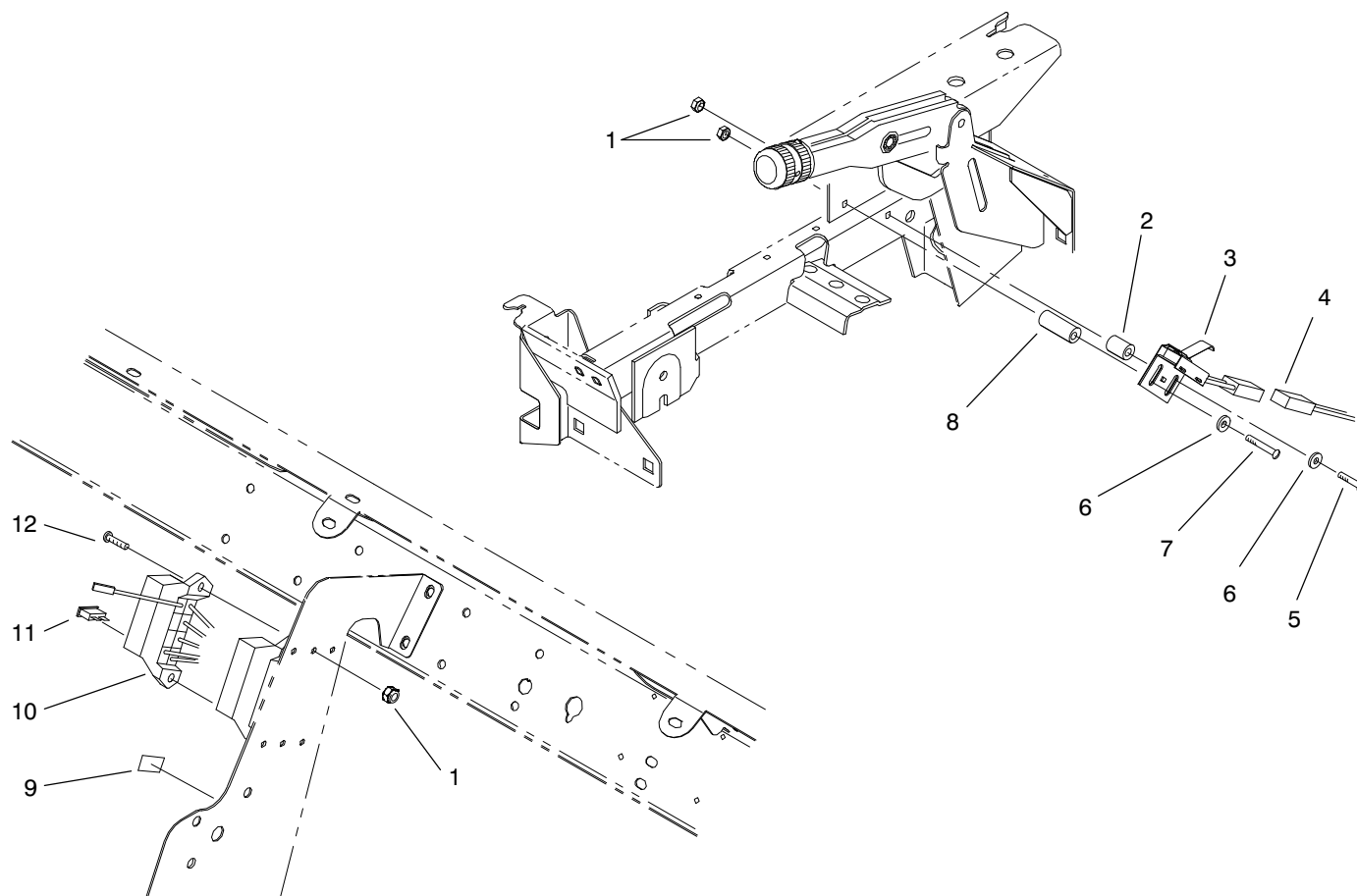

T-1962

Switch And Fuse Block Assembly

Ref. No.	Part No.	Description	No. Used
1	3296-2	Nut - Lock	4
2	92-2801	Spacer - Switch, Short	1
3	93-3722	Switch - Brake, Parking	1
4	92-2854	Harness - Wire	1
5	3250-23	Screw - Pan Phil. Hd.	1
6	3256-14	Washer - Flat	2

Ref. No.	Part No.	Description	No. Used
7	3250-48	Screw - Pan Phil. Hd.	1
8	92-2800	Spacer - Switch, Long	1
9	93-3941	Decal - Fuse	1
10	92-2641	Harness - Wire, Fuse Block	1
11	218-594	Fuse - 20 Amp	1
12	3250-13	Screw - Pan Phil. Hd.	2

Electrical Schematic

