



**Greensmaster<sup>®</sup> 3100**  
**2 Wheel Drive Traction Unit**  
Model No. 04353—20000001 and Up

## Parts Catalog

### Ordering Replacement Parts

To order replacement parts, please supply: the part number, the quantity, and the description of each part desired.

### Understanding Reference Numbers

Each identified part in an illustration has a reference number. The reference number for a part also appears in the parts list, along with other information about the part.

This catalog uses two special reference number formats, one to indicate parts in a service assembly and another to indicate the quantity of a given part in an illustration.

### Service Assembly Reference Numbers

Parts in service assemblies have reference numbers in the form **a:b**. The **a** represents the reference number of the entire service assembly and the **b** represents a sequential number unique to each part within the service assembly.

For example, a wheel assembly might be identified by reference number **6**, the tire by **6:1**, the valve by **6:2**, and the wheel by **6:3**. When you order the assembly identified by reference number **6**, you receive all parts identified by reference numbers **6:1**, **6:2**, and **6:3**. However, you may also order any part individually.

Reference numbers of this type appear in illustrations and in part lists.

### Reference Numbers Indicating Quantity

In an illustration, if a reference number indicates more than one part, the reference number has the form **nX y**. The **n** represents the quantity of the part, the **X** is the multiplication symbol, and the **y** represents the reference number.

For example, in an illustration, the reference number **2X 37** means that two of the parts identified by reference number **37** are indicated.

## Contents

<b>Description</b>	<b>Page</b>
Control Pedal Assembly .....	4
Control Pedal Assembly (Continued) .....	5
Traction Controls Assembly .....	6
Front Wheel and Brake Assembly .....	7
Hydraulic Drive Motor Assembly No. 92-9199 ..	8
Steering Arm Assembly .....	9
Power Steering Valve No. 92-8690 .....	10
Pull Frame Assembly R.H. ....	11
Hydraulic Cylinder Assembly No. 99-8159 .....	12
Pull Frame Assembly L.H. ....	13
Pull Frame Assembly Rear .....	14
Hydraulic Cylinder No. 99-8160 .....	15
Seat Assembly .....	16
Seat Assembly (Continued) .....	17
Control Valve Installation Assembly .....	18
Control Valve Installation Assembly (Continued) .	19
Engine Installation Assembly .....	20
Hydraulic Pump Installation Assembly .....	21
Hydraulic Pump 92-9764 .....	22
Frame Assembly .....	23
Rear Wheel Assembly .....	24

<b>Description</b>	<b>Page</b>
Hydraulic Cylinder Assembly No. 83-2330 .....	25
Control Panel Assembly .....	26
Electrical Schematic .....	27
Hydraulic Reservoir Assembly .....	28
Fuel Tank Assembly .....	29
Hydraulic Schematic .....	30
Reel Motor Installation Assembly .....	31
Reel Motor No. 94-3506 .....	32
Control Valve Assembly No. 84-2203 (Sections 1&2) .....	33
Control Valve Ass5mbly No. 84-2203 (Sections 1&2)(Continued) .....	34
Control Valve Ass7bly No. 84-2203 (Sections 3 Thru 5) .....	35
Control Valve Assembly No. 84-2203 (Sections 3 Thru 5) (Continued) .....	36
Special Tools .....	37
Special Tools (Continued) .....	38
Engine Briggs & Stratton Model 303447-1179-E1 .....	39-49

## Accessories

<b>Description</b>	<b>Model / Part No.</b>
Individual Reel Shut Off Kit .....	28-2150
Basket Reinforcement Kit .....	26-0900
Thatching Reels .....	04493
Variable Speed Kit .....	04422
Traction Tire .....	231-124
Armrests .....	30707
Spiker .....	04494
Tri-Roller .....	04495
Backlapping Kit .....	92-9656
Backlap Kit - 2 Speed, 3 Position .....	94-1870

<b>Description</b>	<b>Model / Part No.</b>
8 Blade, 4 Bolt (Heavy Duty) Cutting Unit .....	04404
8 Blade, 4 Bolt Cutting Unit .....	04408
11 Blade, 4 Bolt Cutting Unit .....	04406
8 Blade, SPA Cutting Unit .....	04468
11 Blade, SPA Cutting Unit .....	04450
8 Blade, 4 Bolt Cutting Unit .....	04480
11 Blade, 4 Bolt Cutting Unit .....	04481
8 Blade, SPA Cutting Unit .....	04482
11 Blade, SPA Cutting Unit .....	04483
8 Blade, 4 Bolt (Heavy Duty) Cutting Unit .....	04484

## Part Description Abbreviations

Part descriptions in this catalog may include the following abbreviations.

<b>Abbreviation</b>	<b>Meaning</b>	<b>Abbreviation</b>	<b>Meaning</b>
AR .....	as required	INC .....	incorporated
ASM .....	assembly	LH .....	left hand
CARR .....	carriage	NI .....	nylon insert
DEG .....	degrees	PPH .....	Phillips pan head
FH .....	flat head	PTH .....	Phillips truss head
GA .....	gauge	PTO .....	power take off
HF .....	hex flange	RH .....	right hand
HH .....	hex head	SFH .....	slotted fillister head
HHF .....	hex head flange	SHH .....	slotted hex head
HLH .....	hex lag head	SQH .....	square head
HJ .....	hex jam	SHWH .....	slotted hex washer head
HOC .....	height-of-cut	SPH .....	slotted pan head
HS .....	hex socket	SRH .....	slotted round head
HSBH .....	hex socket button head	STD .....	standard
HSFH .....	hex socket flat head	TAP .....	self tapping
HSH .....	hex socket head	TTH .....	Torx truss head
HWH .....	hex washer head	WH .....	wing head
HWHTF .....	hex washer head thread forming		

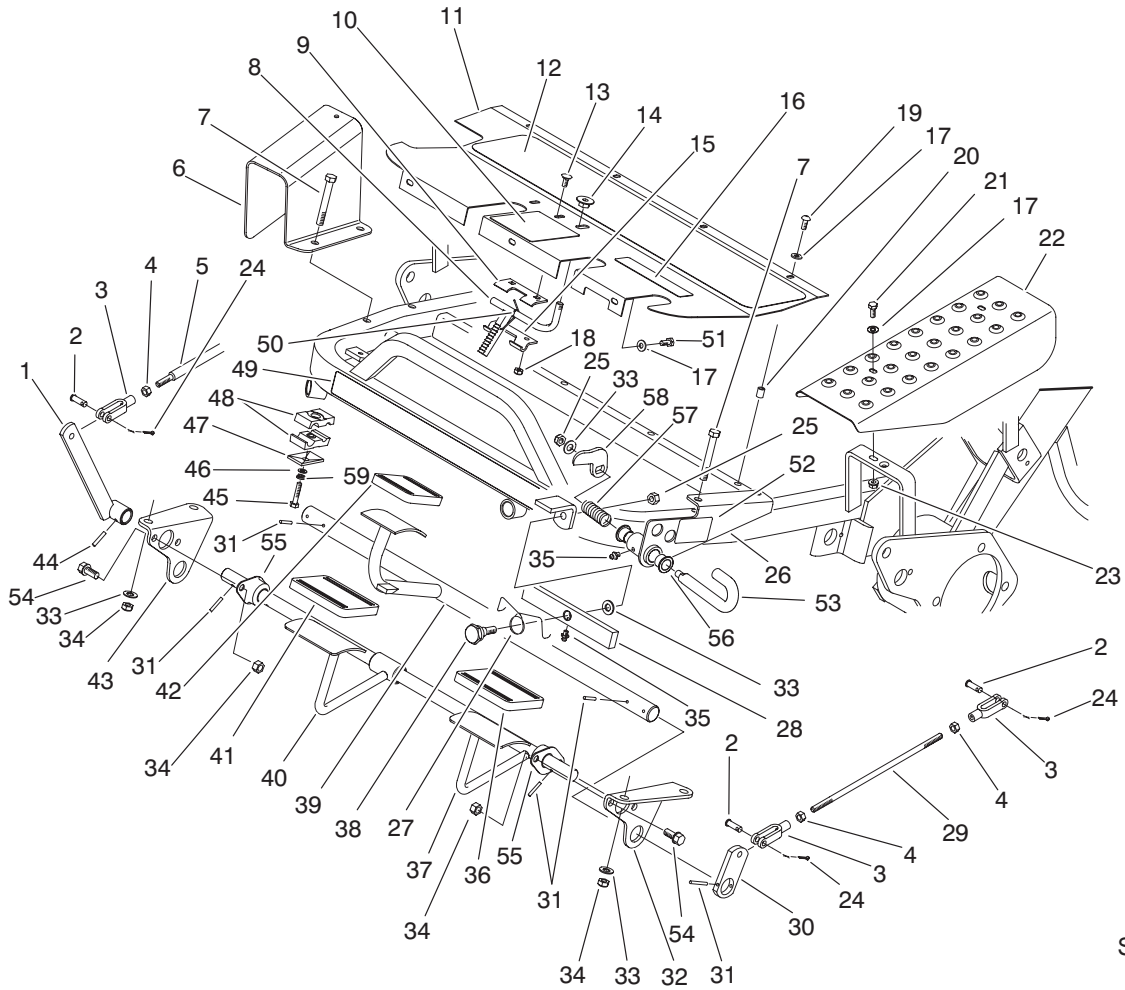

Sheet No.: 2

## Control Pedal Assembly

Ref. No.	Part No.	Qty.	Description
1	49-6200-01	1	Lever-Cutting
2	283-61	5	Pin-Yoke
3	282-2	5	Yoke
4	3220-2	5	Nut-Jam
5	49-5430	1	Control Rod
6	49-6110-01	1	Guard
7	323-13	4	Screw-HH
8	10-7850	1	Latch-Parking Brake
9	95-1628	1	Hinge - Upper
10	93-8062	1	Decal-Parking Brake
11	83-0640-01	1	Footrest Plate
12	49-6120	1	Footrest Pad
13	3229-11	2	Screw-CARR
14	32141-111	1	Nut-Adjusting
15	95-1629	1	Hinge - Lower
16	93-8075	1	Decal-Mow/Lift
17	3256-1	9	Washer-Flat
18	3296-16	2	Nut-Lock, NI
19	3274-31	4	Screw-HSBH
20	32148-6	8	Nut-Insert
21	321-4	2	Screw-HH
22	83-0200-01	1	L/H Cover Plate
23	32128-33	2	Nut-HF
24	3272-6	5	Pin-Cotter
25	3296-39	2	Nut-Lock, NI
26	93-9901-01	1	Bracket-Lockout, Mow

Ref. No.	Part No.	Qty.	Description
27	83-0080	1	Spring-Pivot, Lift
28	83-0060	1	Lift - Pivot
29	27-2270	2	Rod-Brake Adjustment
30	10-8100-01	2	Strap-Brake Shaft
31	32121-35	8	Pin-Roll
32	88-9640-01	1	Bracket-LH Lift Pivot
33	3256-38	6	Washer-Flat
34	3296-59	8	Nut-Lock, NI
35	302-5	2	Fitting-Lube
36	93-7631	1	Lift Foot Pad
37	88-9660	1	Shaft-Cut Control
38	83-2590	1	Shoulder Bolt-Pivot
39	83-0160	1	Shaft-Brake
40	83-0140	1	Pedal-Mow
41	93-7630	1	Pad-Foot
42	93-7629	1	Foot Pad - Brake
43	88-9630-01	1	Bracket-RH Lift Pivot
44	32121-6	1	Pin-Roll
45	321-11	1	Screw-HH
46	3256-22	1	Washer-Flat
47	69-9760	1	Coverplate
48	56-7970	2	Tube Clamp
49	88-9620	1	Decal-Gr 3100
50	10-8140	1	Bracket-Spring, Latch
51	321-3	3	Screw-HH



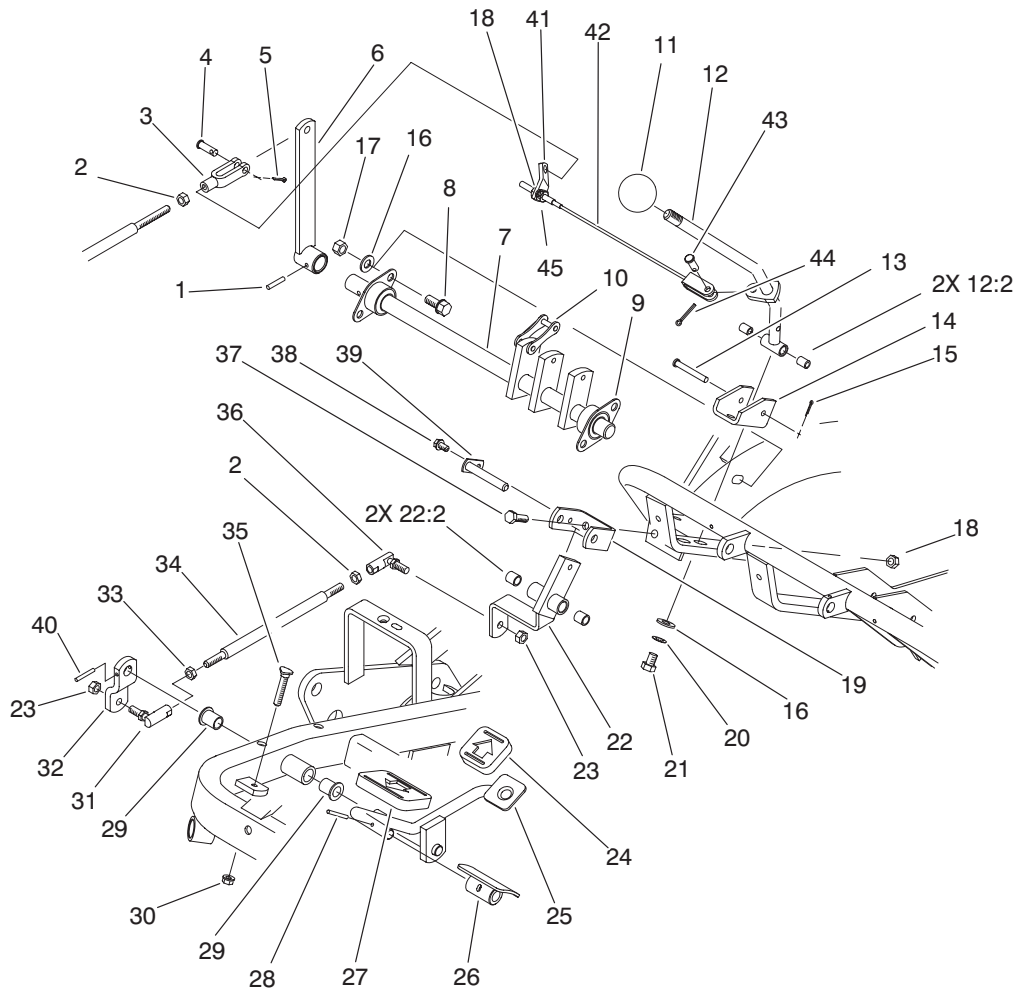

Sheet No.: 3

## Traction Controls Assembly

Ref. No.	Part No.	Qty.	Description
1	32121-6	1	Pin-Roll
2	3220-2	2	Nut-Jam
3	282-2	1	Yoke
4	283-61	1	Pin-Yoke
5	3272-6	1	Pin-Cotter
6	47-5320-01	1	Lever
7	44-0870	1	Cam Shaft ASM
8	3234-1	4	Screw-HHF
9	27-2320	2	Bearing ASM
10	57-6220	5	Link-Connecting
11	233-48	1	Knob
12	93-9934	1	Handle-Traction
12:2	256-251	2	Bushing
13	283-57	1	Pin
14	49-6220	1	Bracket-Control Arm
15	3272-4	1	Pin-Cotter
16	3256-24	6	Washer-Flat
17	3296-59	4	Nut-Lock, NI
18	3296-29	3	Nut-Lock, NI
19	49-6250	1	Bracket-Pivot
20	3254-6	2	Washer-Lock/Int
21	3211-2	2	Screw-HH
22	49-6260	1	Pivot ASM
22:2	256-2	2	Bushing
23	3296-4	2	Nut-Lock NI
24	74-9110	1	Pad-Pedal, Reverse

Ref. No.	Part No.	Qty.	Description
25	83-0540-01	1	Traction Pedal ASM
26	49-6440-03	1	Pedal-Forward
27	74-9100	1	Pad-Pedal, Forward
28	32121-45	1	Pin-Spring
29	256-155	2	Bushing-Flange
30	32128-20	1	Nut-HF
31	2411-42	1	Ball Joint, LH
32	83-0630	1	Traction Pivot Arm
33	3220-20	1	Nut-Jam LH
34	83-0580	1	Rod - Traction Control
35	17-9420	1	Screw - Handle
36	2411-43	1	Ball Joint
37	322-5	2	Screw-HH
38	12-3270	1	Screw
39	49-6290	1	Pivot Shaft ASM
40	32121-51	1	Pin-Roll
41	93-9936	1	Bracket - Traction Return
42	93-9937	1	Cable ASM - Traction
43	283-62	1	Pin-Clevis
44	3272-10	1	Pin-Cotter
45	3217-6	1	Nut-Hex

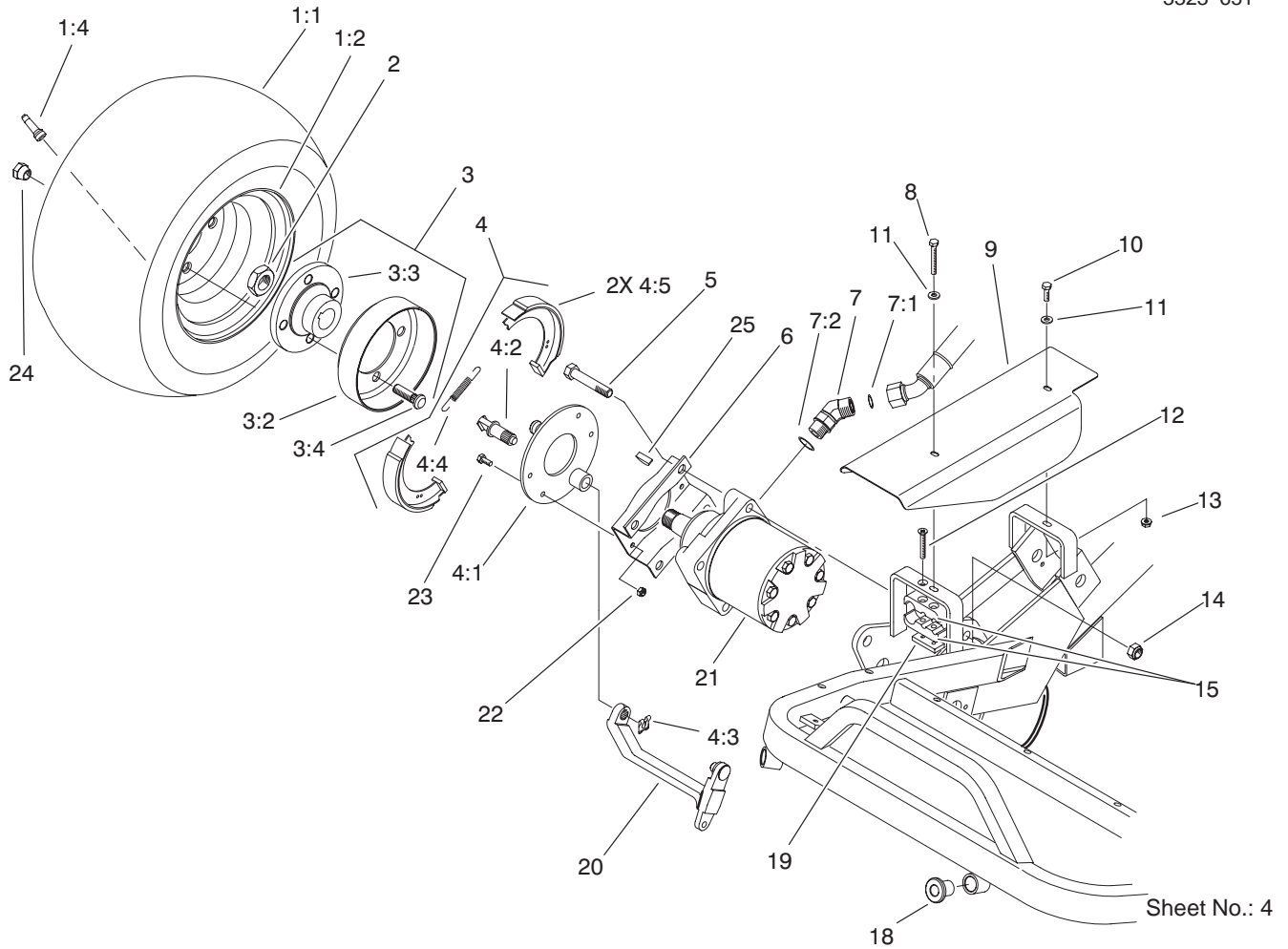

## Front Wheel and Brake Assembly

Ref. No.	Part No.	Qty.	Description
1		2	Wheel & Tire ASM
1:1	28-3680	1	Tire
1:2	217-60	1	Rim
1:4	232-24	1	Stem-Valve
*1:5	232-37	1	Tube
2	26-3790	2	Nut-Lock
3	10-6821	2	Brake Drum ASM
3:2	10-6850	1	Drum-Brake
3:3	10-6870-03	1	Wheel Hub
3:4	85-6540	4	Stud-Drive
4	71-1500	2	Brake Assembly
4:1	70-9870	1	Plate-Backing
4:2	70-9860	1	Cam-Brake
4:3	70-9850	1	Clip-Retaining
4:4	70-9880	2	Spring-Return
4:5	70-9840	2	Shoe-Brake
5	325-11	8	Screw-HH
6	84-2000-03	2	Bracket-Brake
7	340-14	4	Fitting-Hydraulic 45 DEG
7:1	237-65	1	O-Ring
7:2	237-80	1	O-Ring
8	321-11	1	Screw-HH
9	83-0190-01	1	Cover-RH
10	321-4	1	Screw-HH
11	3256-22	2	Washer-Flat

Ref. No.	Part No.	Qty.	Description
12	32108-100	1	Screw-FH
13	32128-33	1	Nut-HF
14	3296-23	8	Nut-Lock, NI
15	57-6140	2	Clamp Half-Tube
18	83-1700	2	Bushing - Flange
19	83-1220	1	Plate-Clamp
20	93-2096	2	Lever - Brake
21	92-9199	2	Motor-Hydraulic
22	3296-42	8	Nut-Lock
23	321-5	8	Screw-HH
24	242-50	8	Nut-Lug
25	3257-42	2	Key-Woodruff

\* Not illustrated



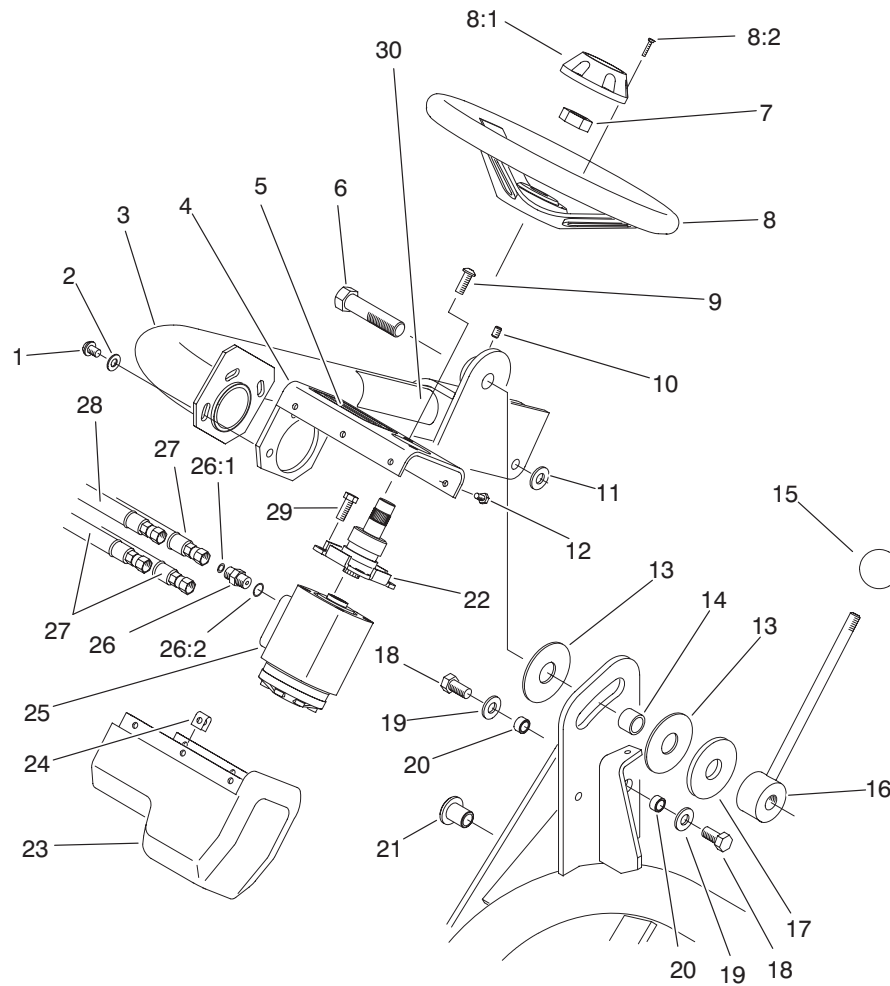

Sheet No.: 5

## Steering Arm Assembly

Ref. No.	Part No.	Qty.	Description	Ref. No.	Part No.	Qty.	Description
1	3274-80	3	Screw-HH	24	3290-277	6	Nut-Speed
2	3256-80	3	Washer-Flat	25	92-8690	1	Steering Control Valve
3	83-0650-01	1	Arm-Steering	26	340-1	4	Adapter
4	83-0780-03	1	Support-Steering Valve	26:1	237-35	1	O-Ring
5	93-8063	1	Decal-Warning	26:2	237-42	1	O-Ring
6	83-0750	1	Screw-HH LH	27	83-1350	3	Hose-Hydraulic
7	47-6990	1	Nut	28	83-1360	1	Hose-Hydraulic
8	68-5130	1	Steering Wheel	29	323-4	2	Screw-HH
8:1	68-5140	1	Cap-Steering Wheel	30	93-8068	1	Decal-Steering Arm
8:2	32144-21	1	Screw F/W				
9	3274-63	2	Screw-HSH				
10	3246-3	1	Screw-HS				
11	65-6390	1	Washer - Thrust, Plain				
12	3274-39	6	Screw-HSBH				
13	83-0740	2	Disc - Friction				
14	83-0730	1	Spacer - Lockup				
15	233-48	1	Knob				
16	83-0700-03	1	Handle-Lockup				
17	83-0760	1	Spacer - Lockup Plate				
18	325-4	2	Screw-HH				
19	3256-26	2	Washer-Flat				
20	47-2890	2	Bushing				
21	83-1700	1	Bushing - Flange				
22	83-1420	1	Column-Steering				
23	83-0810	1	Cover - Steering				



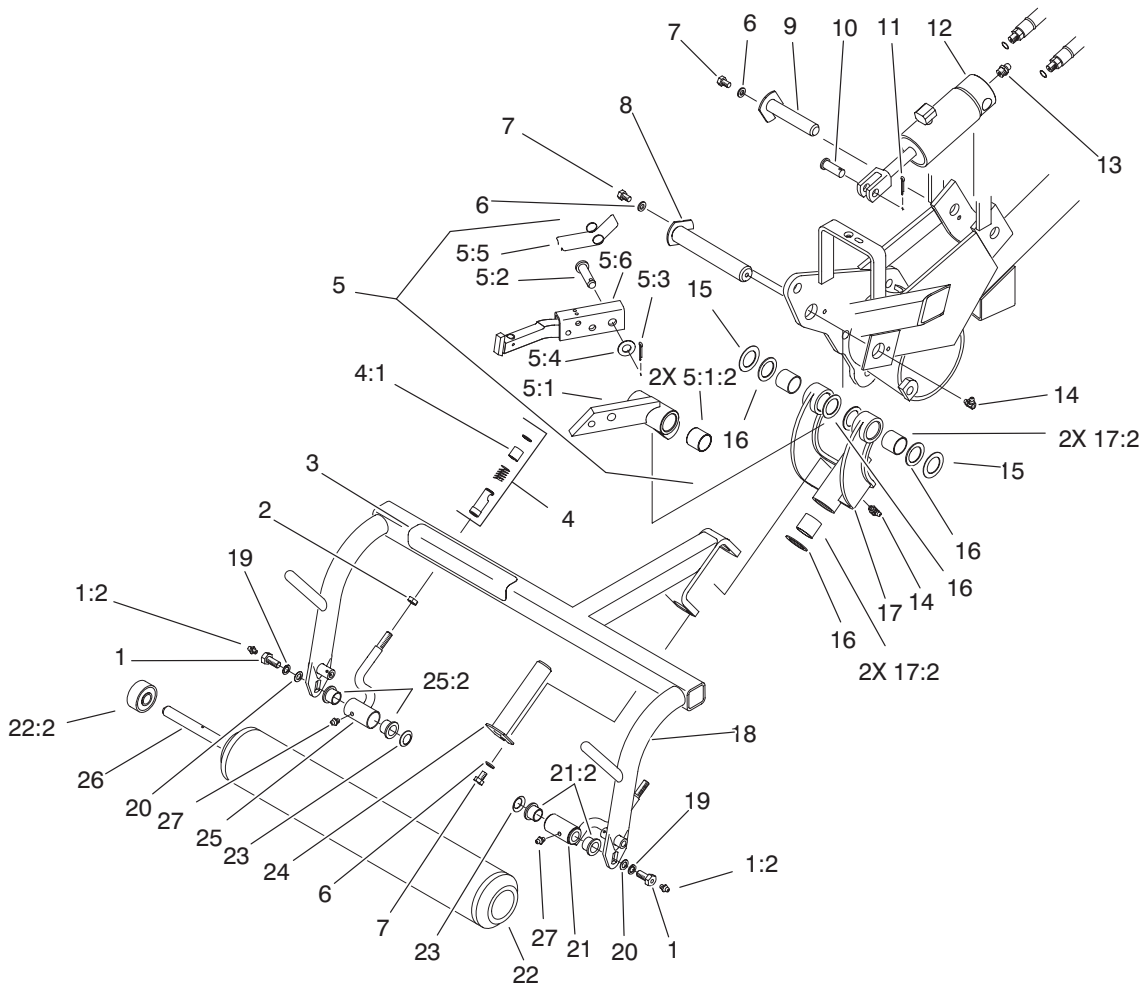

Sheet No.: 6

### Pull Frame Assembly R.H.

Ref. No.	Part No.	Qty.	Description
1	11-0160	2	Roller Shaft Screw ASM
1:2	302-5	1	Fitting-Lube
2	3220-3	2	Nut-Jam
3	93-8064	1	Decal-Danger
4	99-1460	2	Ball Joint Receiver ASM
4:1	99-1461	1	Sleeve - Ball Joint
5		1	RH Lift Arm ASM
5:1	62-2440	1	Lift Arm ASM
5:1:2	3-0348	2	Bushing
5:2	63-8750	1	Pivot Pin
5:3	3272-11	1	Pin-Cotter
5:4	3256-26	1	Washer-Flat
5:5	57-7650	1	Spring-Torsion
5:6	94-5588-01	1	Bar-Lift, R/H
6	3256-23	3	Washer-Flat
7	322-1	3	Screw-HH
8	10-6110	1	Pin-Hinge
9	10-6060	1	Pin-Pivot, Ram
10	283-8	1	Pin-Clevis
11	3272-11	1	Pin-Cotter
12	99-8159	1	Hydraulic Cylinder ASM
13	302-2	1	Fitting-Grease
14	302-60	2	Fitting-Lube

Ref. No.	Part No.	Qty.	Description
15	5-1226	2	Washer
16	10-8110	6	Washer-Thrust
17	10-7820	1	Pivot Hinge ASM
17:2	3-0348	4	Bushing
18	92-9177-01	1	Frame-Pull, RH
19	3253-21	2	Washer-Lock/Sp
20	3256-24	2	Washer-Flat
21	92-0586	1	Pull Arm ASM
21:2	3-1506	2	Bushing
22	52-2720	1	Roller ASM
22:2	251-141	2	Bearing-Ball
23	3290-317	2	Washer-Spring
24	10-6090	1	Pin-Pivot
25	92-0585	1	Pull Arm ASM
25:2	3-1506	2	Bushing
26	21-8470	1	Shaft-Roller
27	302-5	2	Fitting-Lube



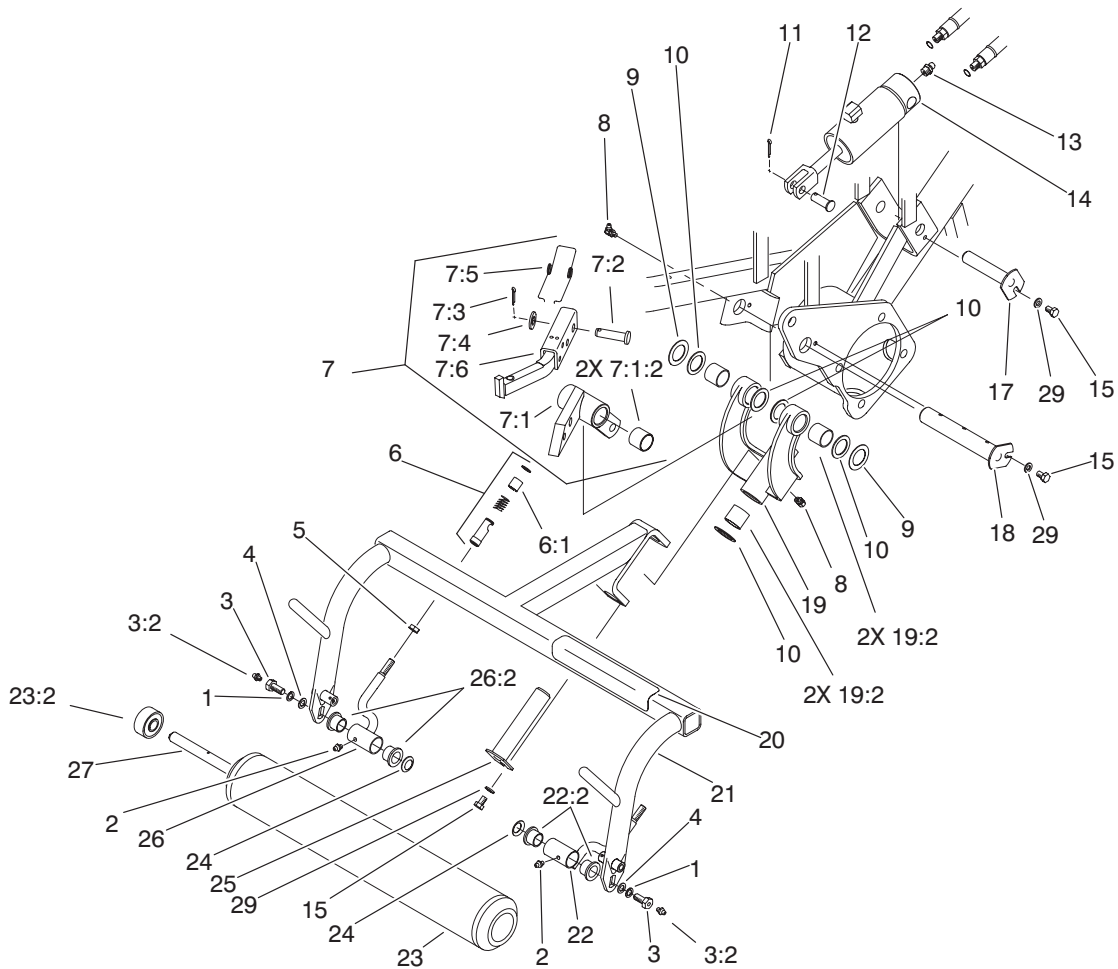

Sheet No.: 7

### Pull Frame Assembly L.H.

Ref. No.	Part No.	Qty.	Description
1	3253-21	2	Washer-Lock/Sp
2	302-5	2	Fitting-Lube
3	11-0160	2	Roller Shaft Screw
3:2	302-5	1	Fitting-Lube
4	3256-24	2	Washer-Flat
5	3220-3	2	Nut-Jam
6	99-1460	2	Ball Joint Receiver
6:1	99-1461	1	Sleeve - Ball Joint
7		1	LH Lift Arm ASM
7:1	62-2460	1	Lift Arm ASM
7:1:2	3-0348	2	Bushing
7:2	63-8750	1	Pivot Pin
7:3	3272-11	1	Pin-Cotter
7:4	3256-26	1	Washer-Flat
7:5	57-7650	1	Spring-Torsion
7:6	94-5586-01	1	Bar-Lift, LH
8	302-60	2	Fitting-Lube
9	5-1226	2	Washer
10	10-8110	6	Washer-Thrust
11	3272-11	1	Pin-Cotter
12	283-8	1	Pin-Clevis
13	302-2	1	Fitting-Grease
14	99-8159	1	Hydraulic Cylinder
			ASM

Ref. No.	Part No.	Qty.	Description
15	322-1	3	Screw-HH
17	10-6060	1	Pin-Pivot, Ram
18	10-6110	1	Pin-Hinge
19	10-7820	1	Pivot Hinge ASM
19:2	3-0348	4	Bushing
20	93-8064	1	Decal-Danger
21	92-9176-01	1	Frame-Pull, LH
22	92-0586	1	Pull Arm ASM
22:2	3-1506	2	Bushing
23	52-2720	1	Roller ASM
23:2	251-141	2	Bearing-Ball
24	3290-317	2	Washer-Spring
25	10-6090	1	Pin-Pivot
26	92-0585	1	Pull Arm ASM
26:2	3-1506	2	Bushing
27	21-8470	1	Shaft-Roller
29	3256-23	3	Washer-Flat

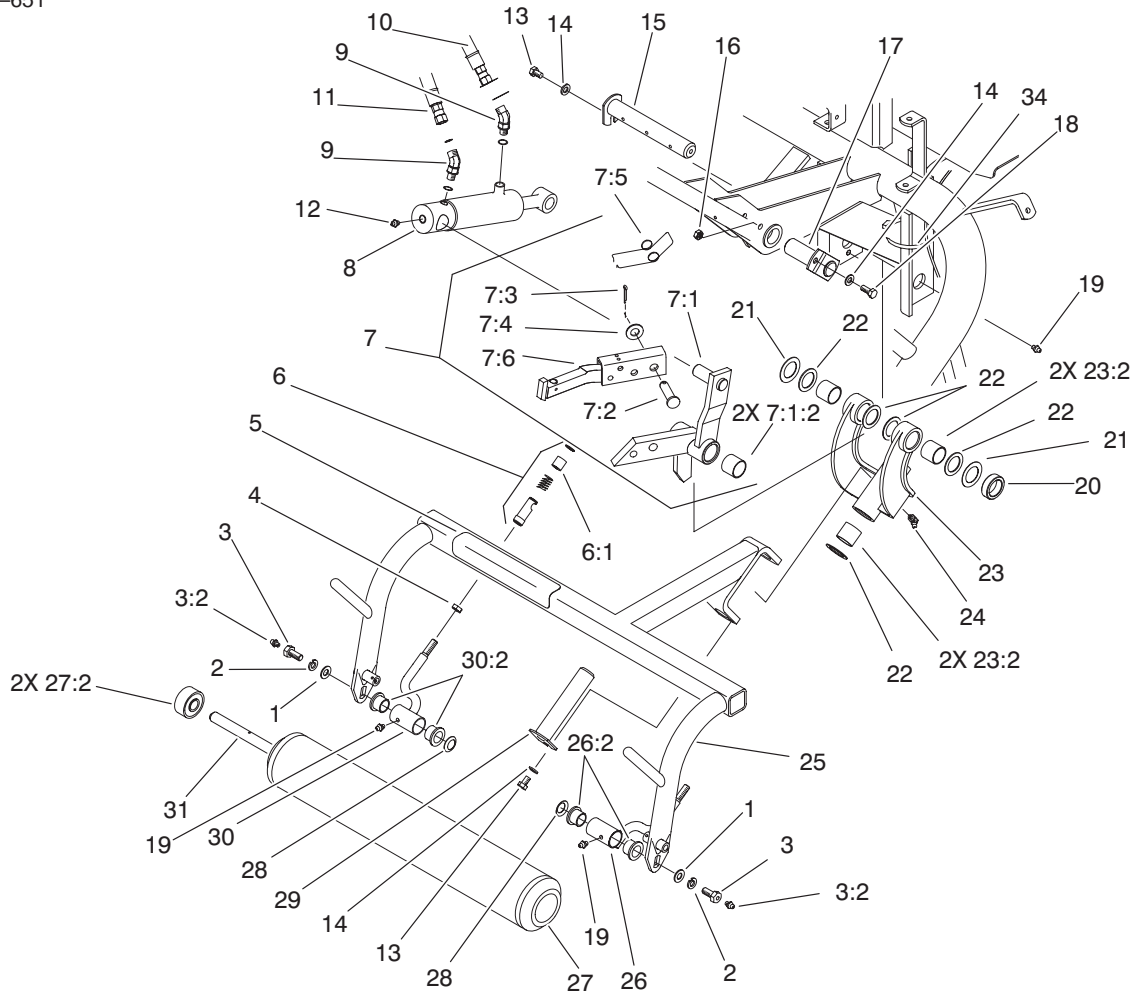

Sheet No.: 8

### Pull Frame Assembly Rear

Ref. No.	Part No.	Qty.	Description
1	3256-24	2	Washer-Flat
2	3253-21	2	Washer-Lock/Sp
3	11-0160	2	Roller Shaft Screw
3:2	302-5	1	Fitting-Lube
4	3220-3	2	Nut-Jam
5	93-8064	1	Decal-Danger
6	99-1460	2	Ball Joint Receiver
6:1	99-1461	1	Sleeve - Ball Joint
7		1	Center Lift Arm ASM
7:1	68-5380	1	Center Lift Arm ASM
7:1:2	3-0348	2	Bushing
7:2	63-8750	1	Pivot Pin
7:3	3272-11	1	Pin-Cotter
7:4	3256-26	1	Washer-Flat
7:5	57-7650	1	Spring-Torsion
7:6	62-2420-01	1	Bar-Lift
8	99-8160	1	Hydraulic Cylinder
9	340-103	2	Fitting
10	83-1680	1	Hose-Hydraulic
11	88-9700	1	Hose-Hydraulic
12	302-2	1	Fitting-Grease
13	322-1	2	Screw-HH
14	3256-23	3	Washer-Flat

Ref. No.	Part No.	Qty.	Description
15	27-2550	1	Pin-Hinge
16	3296-29	1	Nut-Lock,NI
17	68-5560	1	Pin-Cylinder,Pivot
18	322-3	1	Screw-HH
19	302-5	3	Fitting-Lube
20	93-2384	1	Spacer - Carrier
21	5-1226	2	Washer
22	10-8110	6	Washer-Thrust
23	10-7820	1	Pivot Hinge ASM
23:2	3-0348	4	Bushing
24	302-60	1	Fitting-Lube
25	86-9820-01	1	Frame-Pull, R/H & Rr
26	92-0586	1	Pull Arm ASM
26:2	3-1506	2	Bushing
27	52-2720	1	Roller ASM
27:2	251-141	2	Bearing-Ball
28	3290-317	2	Washer-Spring
29	10-6090	1	Pin-Pivot
30	92-0585	1	Pull Arm ASM
30:2	3-1506	2	Bushing
31	21-8470	1	Shaft-Roller
34	3290-379	1	Tie-Cable

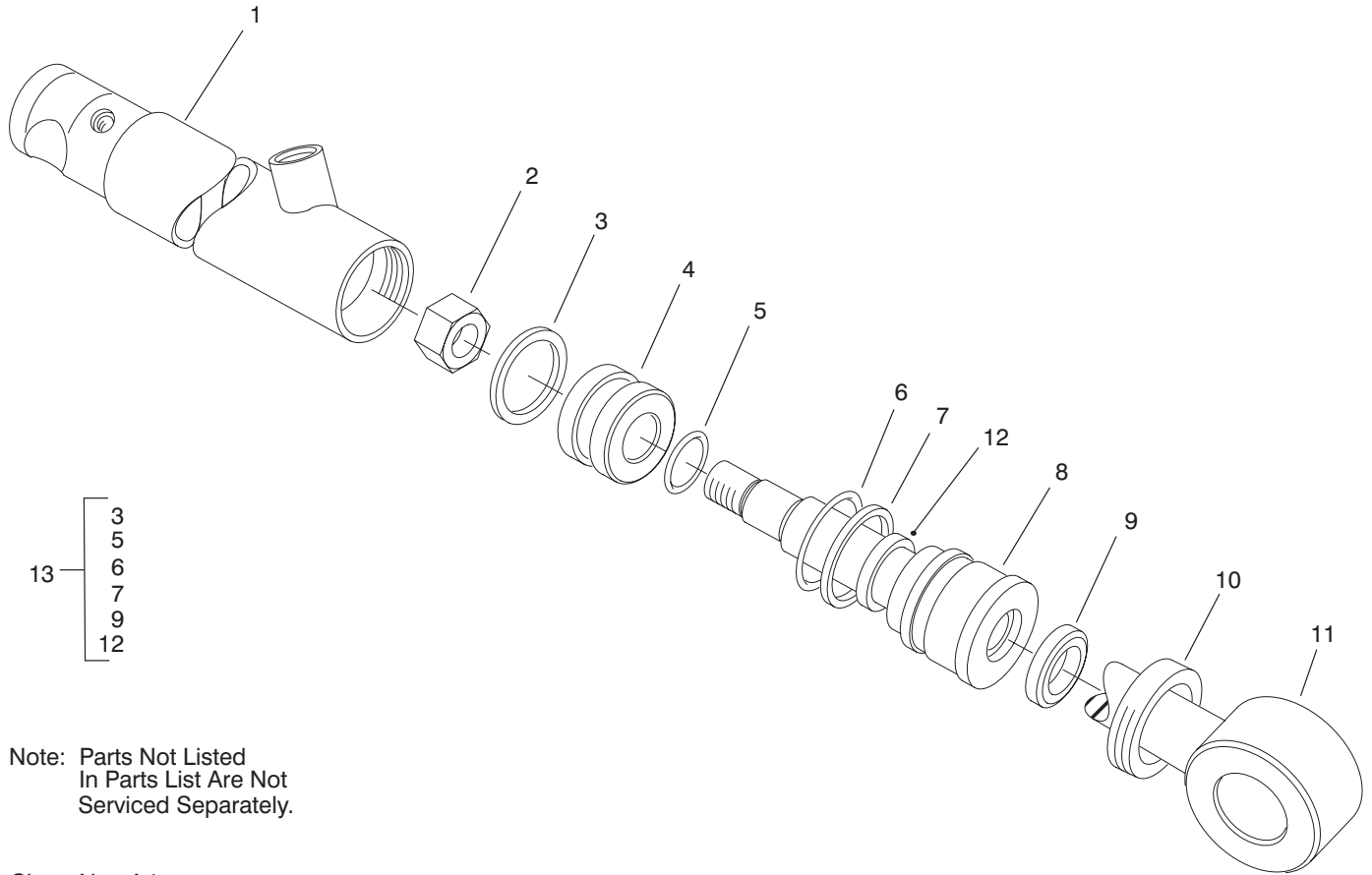

Note: Parts Not Listed  
In Parts List Are Not  
Serviced Separately.

Sheet No.: A4  
T-3155-1

## Hydraulic Cylinder No. 99-8160

Ref. No.	Part No.	Qty.	Description
2	32152-10	1	Locknut – Top Deform
4	70-2780	1	Piston
*13	99-8162	1	Kit – Seal Repair, 1.50

Ref. No.	Part No.	Qty.	Description

\* Not illustrated

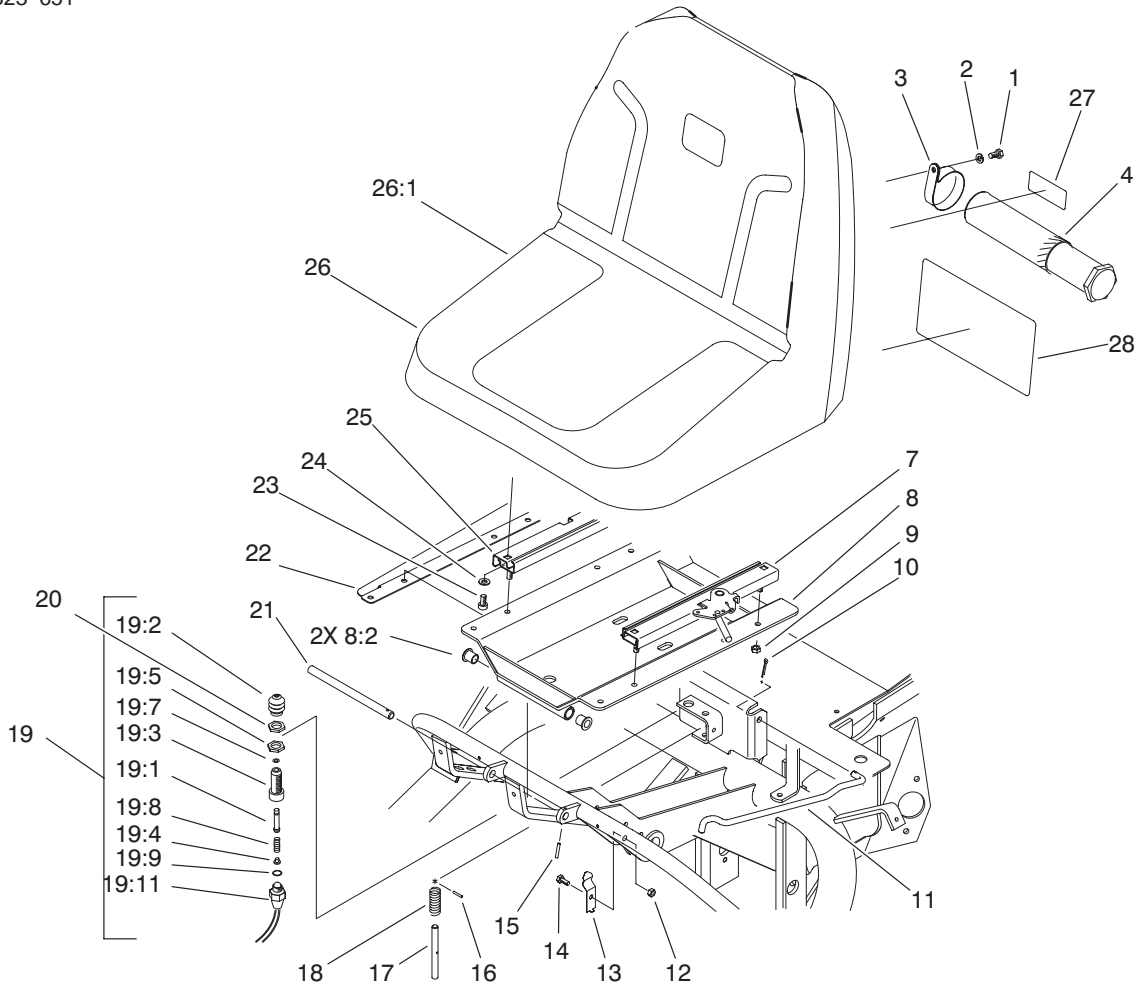

Sheet No.: 9

### Seat Assembly

Ref. No.	Part No.	Qty.	Description
1	322-2	2	Screw-HH
2	3253-4	2	Washer-Lock/Sp
3	2412-133	2	R-Clamp
4	74-0720	1	Tube-Manual
7	51-0790	1	L/H Seat Adjuster-4"
8	83-1270	1	Seat Support ASM
8:2	256-155	2	Bushing-Flange
9	3296-29	4	Nut-Lock,NI
10	3272-11	1	Pin-Cotter
11	68-5100	1	Prop Seat Rod
12	3296-16	1	Nut-Lock, NI
13	68-5310	1	Prop Rod Clip
14	321-3	1	Screw-HH
15	32121-45	1	Pin-Spring
16	3284-3	1	Groove Pin
17	51-0350	1	Seat Spring Pin
18	3-6685	1	Spring
19	43-9071	1	Limit Switch ASM
19:1	43-8860	1	Switch Plunger
19:2	43-8870	1	Switch Boot
19:3	43-8620	1	Guide-Pin,Switch
19:4	43-8610	1	Guide
19:5	218-461	1	Nut-HH
19:7	237-7	1	O Ring
19:8	43-8600	1	Spring-Compression
19:9	237-30	1	O-Ring

Ref. No.	Part No.	Qty.	Description
19:11	72-4320	1	Switch
20	218-461	1	Nut-HH
21	49-5880	1	Shaft-Support, Seat
22	83-1840-01	1	R/H Valve Cover
23	3274-12	4	Screw-HSH
24	3256-23	4	Washer-Flat
25	51-0780	1	Slider-Seat
26	100-3187	1	Seat ASM
26:1	92-6534	1	Shell
*26:2	351-80	1	Clip
*26:3	351-78	1	Edging
*26:4	100-6411	1	Cushion-Replacement
27	93-8067	1	Decal-Hydraulic Oil
*28	93-7257	1	Decal-Service, Portugese
*28	93-7258	1	Decal-Service, Norwegian
*28	93-7259	1	Decal-Service, Finnish
*28	93-7260	1	Decal-Service, Danish
*28	93-7261	1	Decal-Service, Dutch
28	94-8036	1	Decal - Service
*28	83-2490	1	Service Decal
*28	84-9240	1	Decal - Service
*28	84-9250	1	Decal - Service
*28	84-9280	1	Decal - Service

\* Not illustrated

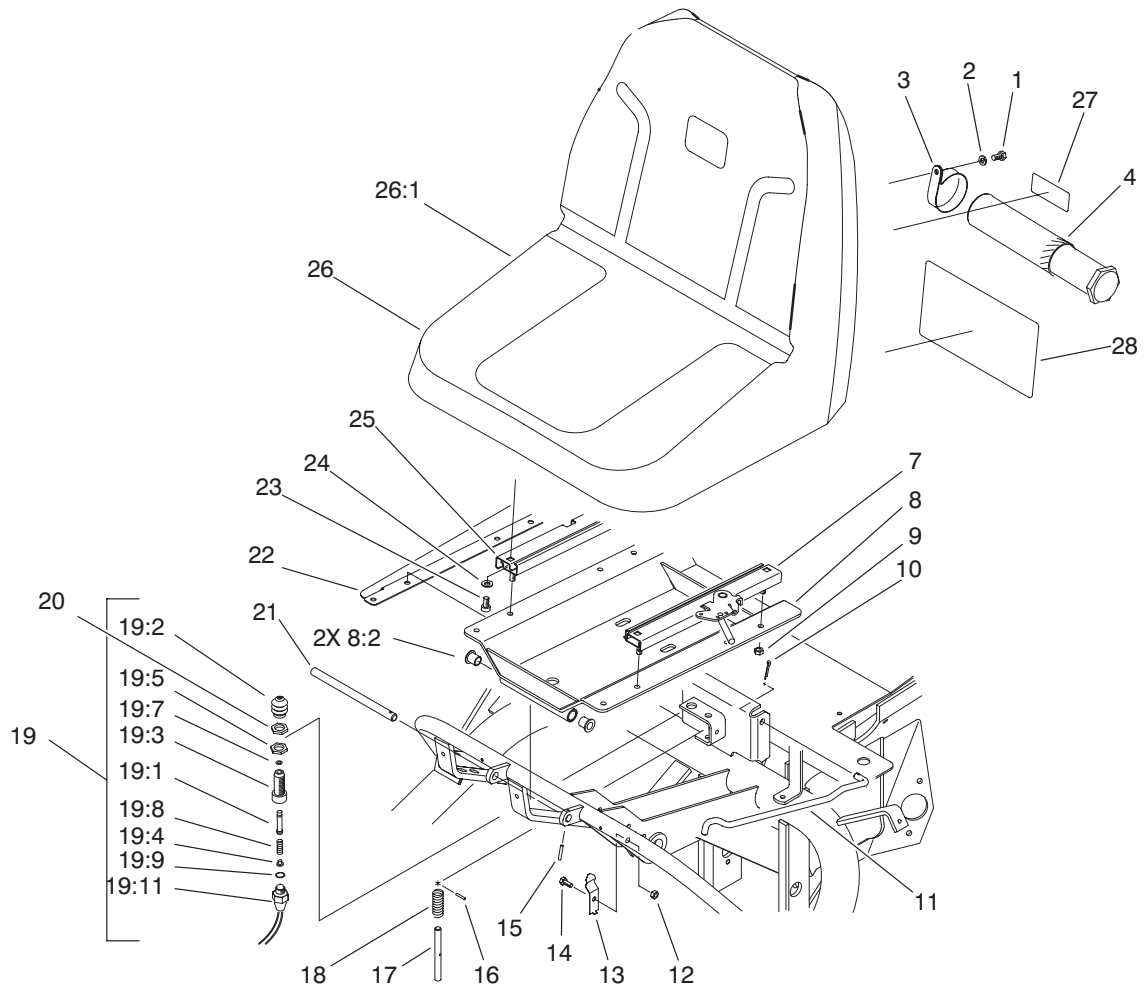

Sheet No.: 9

### Seat Assembly (Continued)

Ref. No.	Part No.	Qty.	Description
*28	84-9270	1	Decal – Service
*28	84-9260	1	Decal – Service

Ref. No.	Part No.	Qty.	Description

\* Not illustrated

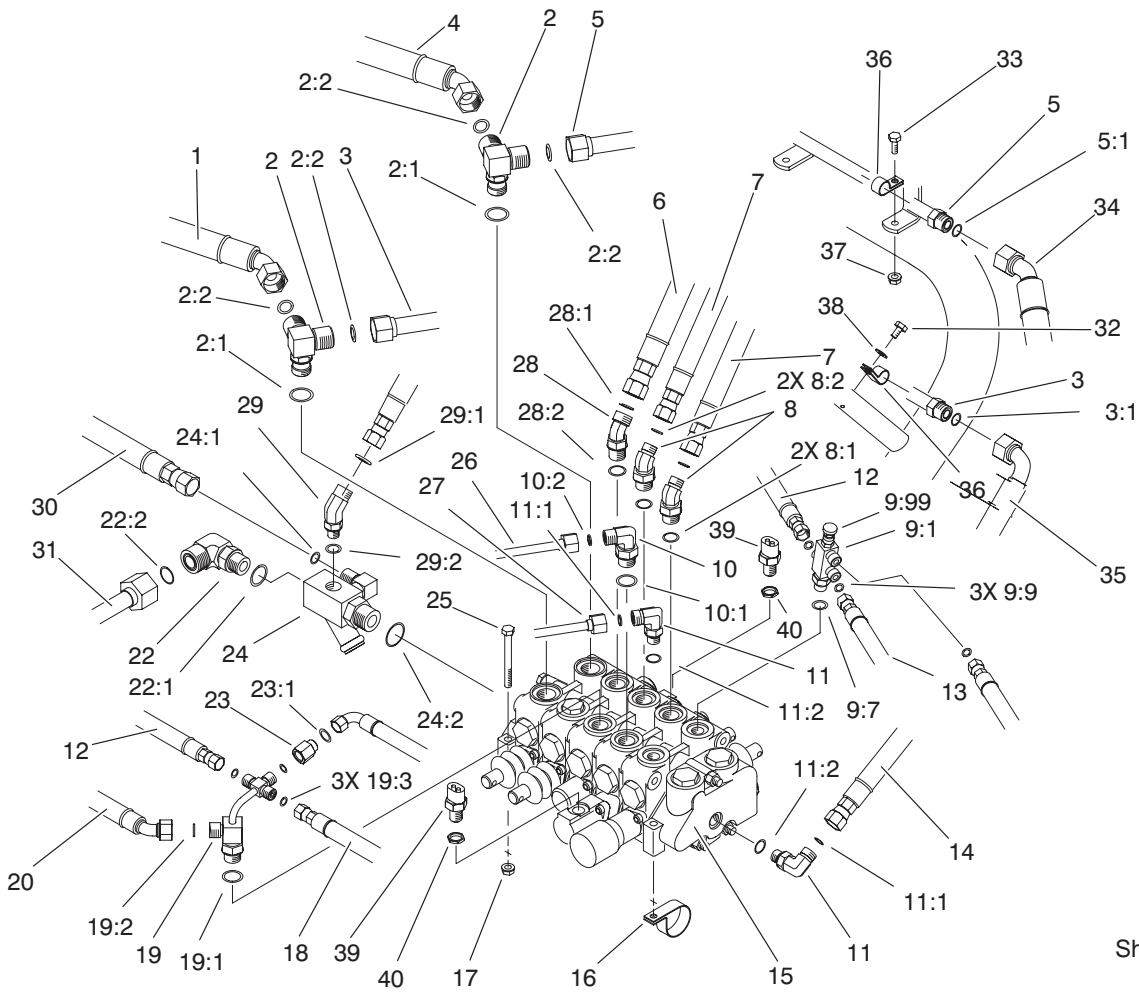

Sheet No.: 10

## Control Valve Installation Assembly

Ref. No.	Part No.	Qty.	Description
1	98-0647	1	Hose-Hydraulic
2	63-4050	2	Fitting
2:1	237-80	1	O-Ring
2:2	237-65	2	O-Ring
3	70-7130	1	Tube Line
3:1	237-65	2	O-Ring
4	98-0646	1	Hose-Hydraulic
5	83-1200	1	Tube-Traction, LH Lower
5:1	237-65	1	O-Ring
6	98-2151	1	Hose-Hydraulic
7	98-0649	2	Hose-Hydraulic
8	340-138	2	Fitting
8:1	237-79	1	O-Ring
8:2	237-22	1	O-Ring
9	93-2556	1	Needle Valve ASM
9:1	93-2555	1	Fitting - Body
9:7	237-42	1	O-Ring
9:9	237-21	3	O Ring
9:99	93-2554	1	Needle ASM
10	340-18	1	Fitting
10:1	237-79	1	O-Ring
10:2	237-22	1	O-Ring
11	340-77	2	Fitting-Hyd. 90°
11:1	237-22	1	O-Ring
11:2	237-42	1	O-Ring

Ref. No.	Part No.	Qty.	Description
12	92-9767	2	Hose
12:1	237-78	1	O-Ring
13	83-1690	1	Hose-Hydraulic
13:1	237-78	1	O-Ring
14	98-2150	1	Hose-Hydraulic
15	84-2203	1	Control Valve-5 Spool
16	304-61	1	Clamp-Hose
17	32128-20	3	Nut-HF
18	63-3850	1	Hose ASM
18:1	237-78	1	O-Ring
19	83-1670	1	Fitting - Tube Assy
19:1	237-79	1	O-Ring
19:2	237-22	1	O-Ring
19:3	237-21	3	O Ring
20	95-5986	1	Hose-Hydraulic
22	340-16	1	Fitting
22:1	237-80	1	O-Ring
22:2	237-58	1	O-Ring
23	71-0990	1	Orifice
23:1	237-21	1	O Ring
24	68-5260	1	Manifold-Tee
24:1	237-30	1	O-Ring
24:2	237-81	1	O-Ring
25	322-14	3	Screw-HH
26	63-4030	1	Hydraulic Tube
27	63-4020	1	Hydraulic Tube



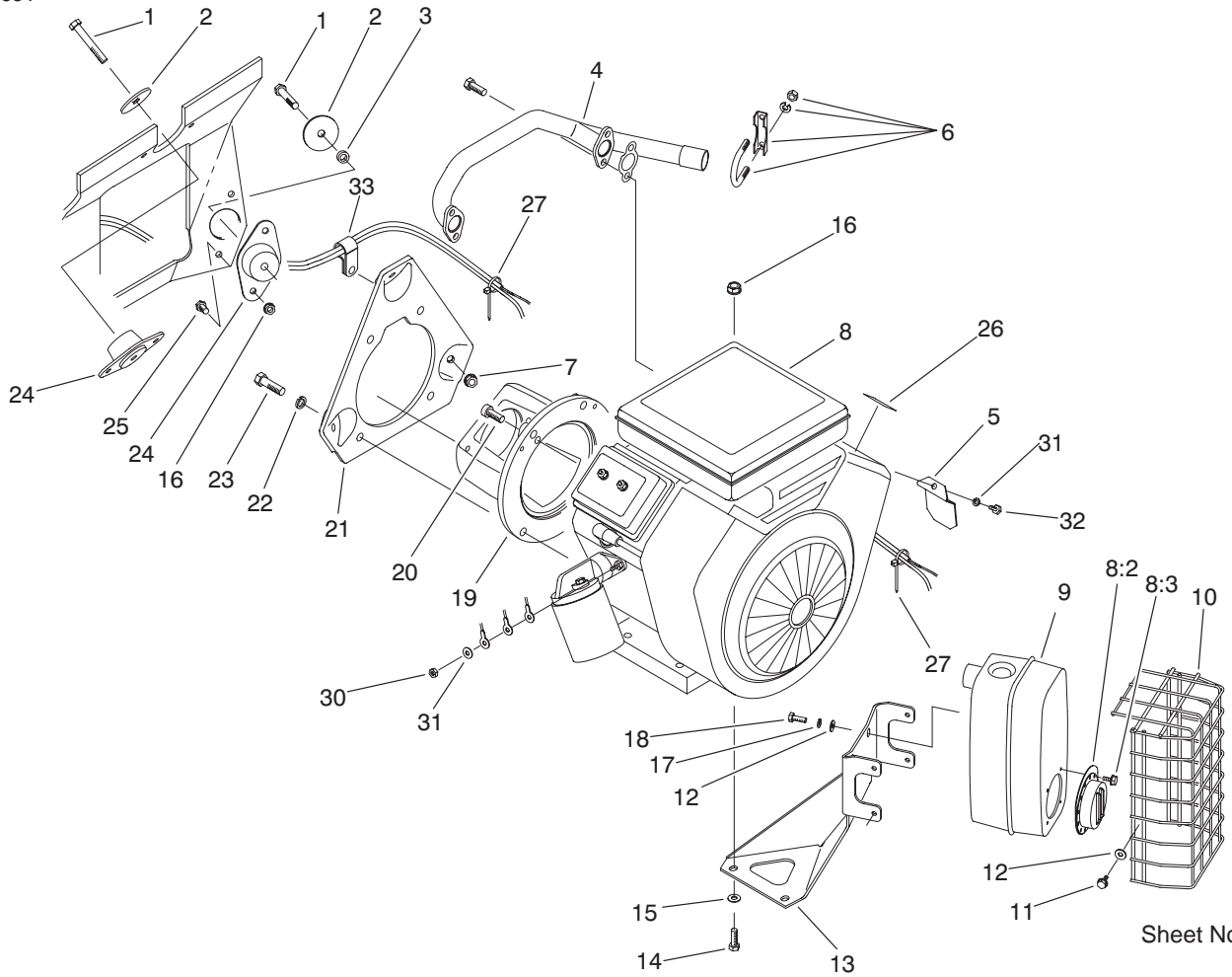

Sheet No.: 11  
T-xxxx

## Engine Installation Assembly

Ref. No.	Part No.	Qty.	Description
1	323-12	3	Screw-HH
2	83-1040	3	Washer - Flat
3	83-1050	2	Spacer
4	83-1080	1	Exhaust Manifold ASM
5	83-2310	1	Shield - Regulator
6	2112-11	1	Muffler Clamp
7	3290-357	3	Nut-Flange, Lock
8	98-0636	1	Engine ASM
8:2	83-2220	1	Deflector-Exhaust
8:3	83-2230	4	Screw-HH
9	98-0616	1	Muffler ASM
10	83-1400-03	1	Muffler Shield
11	12-3270	4	Screw
12	3256-1	8	Washer-Flat
13	83-1630-03	1	Bracket-Muffler Support
14	322-8	2	Screw-HH
15	3256-23	2	Washer-Flat
16	32128-20	8	Nut-HF
17	3253-3	4	Washer-Lock/Sp
18	49-2040	4	Screw-Taptite
19	83-1060-03	1	Adapter-Pump
20	3274-7	2	Screw-HSH
21	85-8120-03	1	Plate-Engine Mount
22	3253-6	4	Washer-Lock/Sp
23	324-7	4	Screw-HH

Ref. No.	Part No.	Qty.	Description
24	83-1030	3	Mount-Engine
25	322-3	6	Screw-HH
26	93-8069	1	Decal-Hot Surface
27	3290-379	2	Tie-Cable
30	43-2830	1	Hex Nut
31	43-5930	2	Spring Washer
32	33113-016	1	Screw-HH
33	2412-81	1	Clamp

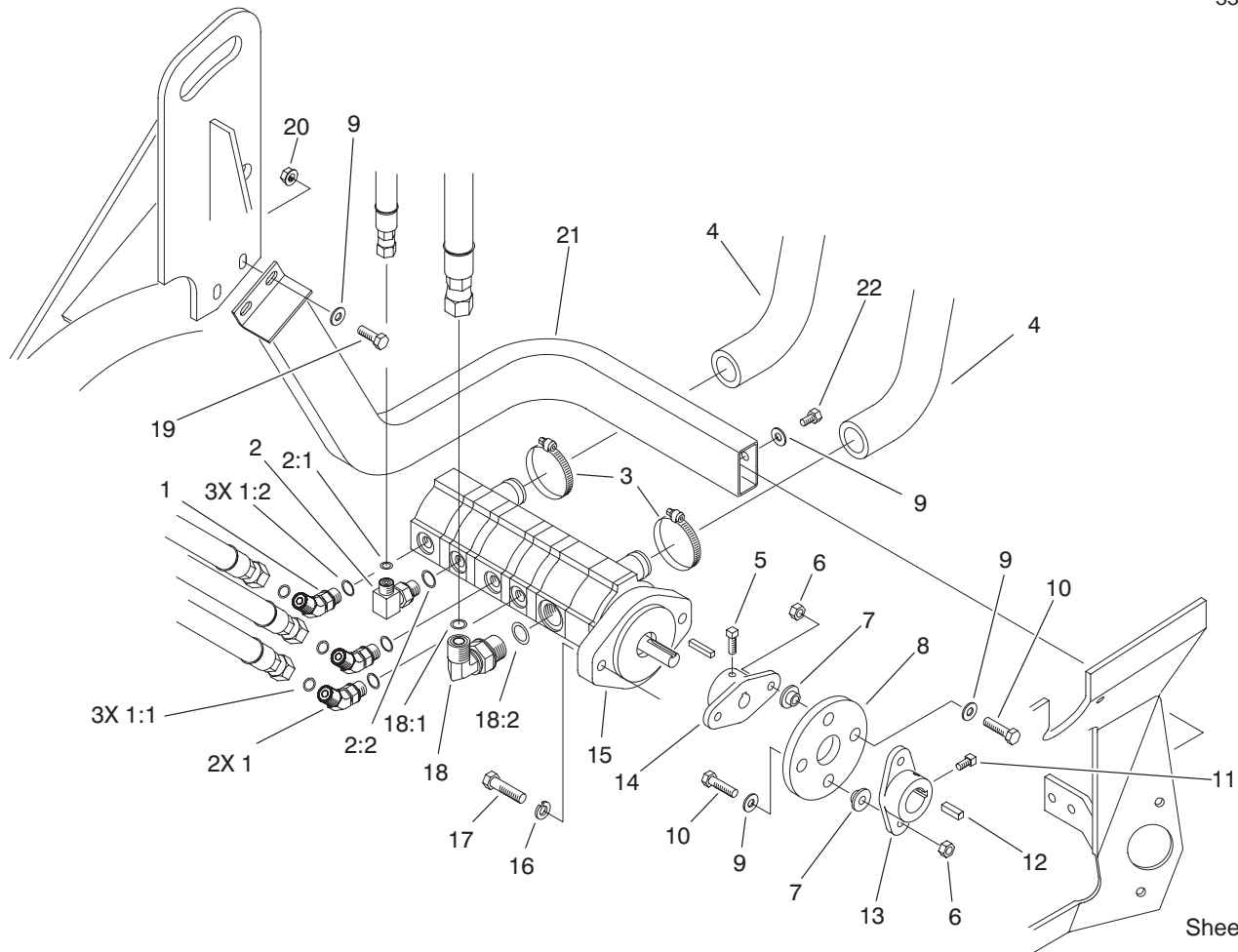

Sheet No.: 12

## Hydraulic Pump Installation Assembly

Ref. No.	Part No.	Qty.	Description
1	340-87	3	Fitting-Hyd., 45°
1:1	237-22	1	O-Ring
1:2	237-42	1	O-Ring
2	340-82	1	Adapter
2:1	237-42	1	O-Ring
2:2	237-35	1	O-Ring
3	2412-34	2	Clamp-Hose
4	83-0910	2	Hose-Inlet, Pump
5	3241-6	2	Screw, Sq Hd
6	3296-29	4	Nut-Lock, NI
7	27-6600	4	Spacer-Coupling
8	44-2230	1	Coupling-Rubber
9	3256-23	8	Washer-Flat
10	322-6	4	Screw-HH
11	3241-2	2	Screw-SQH
12	10-7070	1	Key-Square
13	27-1960	1	Hub-Engine
14	27-1970	1	Hub-Pump
15	92-9764	1	Hydraulic Pump ASM
16	3253-21	2	Washer-Lock/Sp
17	323-8	2	Screw-HH
18	340-105	1	Fitting-Hyd., 90°
18:1	237-30	1	O-Ring
18:2	237-80	1	O-Ring
19	322-4	2	Screw-HH
20	32128-20	2	Nut-HF

Ref. No.	Part No.	Qty.	Description
21	83-1940-01	1	Guard-Pump
22	322-1	2	Screw-HH

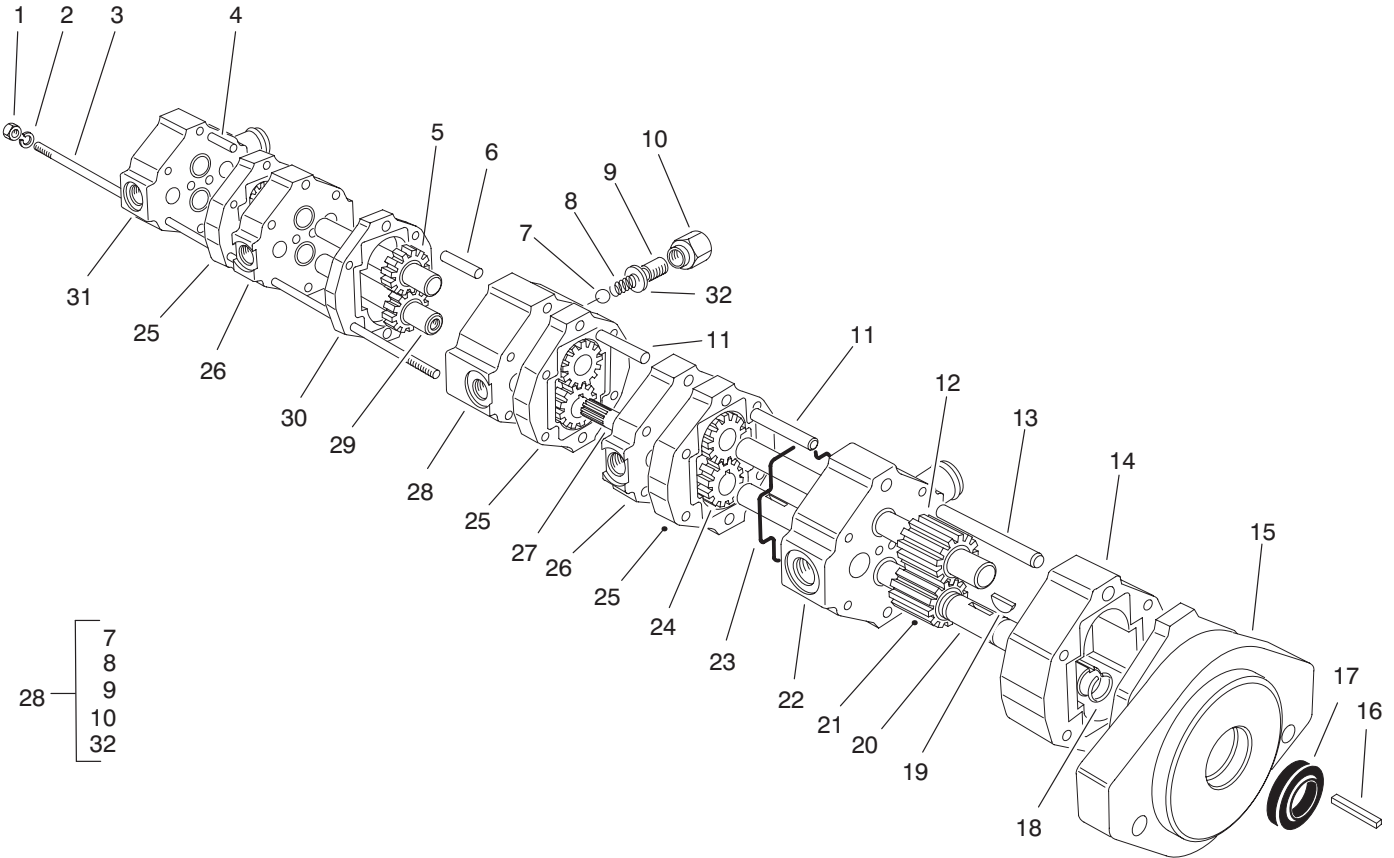

Note: Parts Not Listed  
In Parts List Are Not  
Serviced Separately.

Sheet No.: A6  
T-0645

## Hydraulic Pump 92-9764

Ref. No.	Part No.	Qty.	Description
1	3217-6	4	Nut-Hex
2	354-16	4	Washer
3	354-17	4	Stud
4	354-11	2	Dowel
5	354-9	1	Idler Shaft & Gear ASM
6	354-12	2	Dowel
11	354-13	4	Dowel
12	92-9774	1	Shaft & Gear ASM
13	354-14	2	Dowel Pin
14	92-9766	1	Plate-Gear
15	354-2	1	Body Assembly
16	5-0946	1	Key-Square
17	354-15	1	Seal-Oil
18	353-886	2	Ring-Retaining
19	353-884	4	Key
20	92-9772	1	Shaft-Drive
21	92-9773	1	Gear - 59b
22	354-3	1	Bearing Plate ASM
23	353-922	10	Ring-Seal
24	353-967	6	Gear
25	353-969	3	Plate-Gear
26	353-923	2	Plate
27	354-5	1	Adaptor-Splined
28	354-4	1	Bearing Plate ASM

Ref. No.	Part No.	Qty.	Description
29	354-8	1	Drive Shaft & Gear ASM
30	354-6	1	Plate-Gear
31	354-7	1	Pump Cover Assembly
32	354-35	1	Gasket

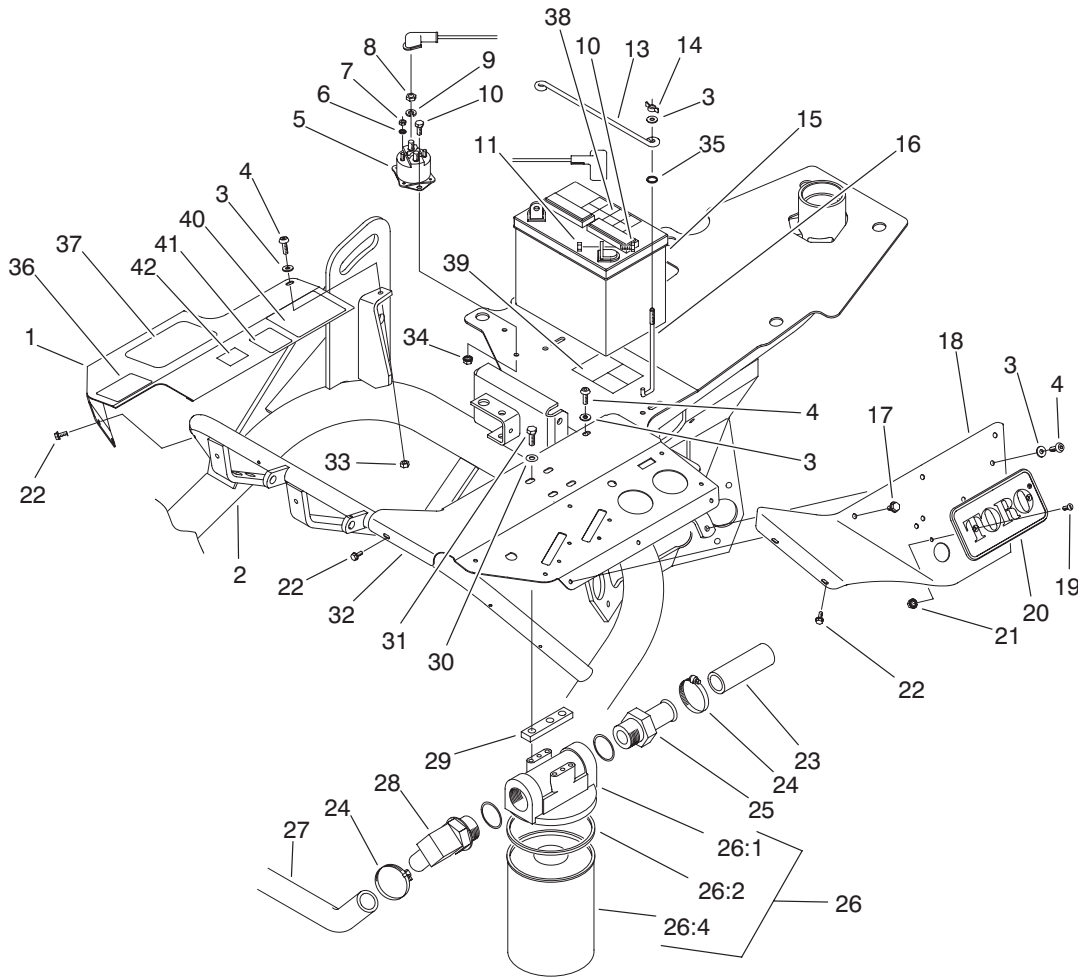

Sheet No.: 13

### Frame Assembly

Ref. No.	Part No.	Qty.	Description
1	94-2694-01	1	Cover-RH
2	92-9164-01	1	Frame ASM
3	3256-22	5	Washer-Flat
4	3274-69	3	Screw-HSBH
5	28-4210	1	Solenoid
6	3254-1	2	Washer-Lock/Int
7	3219-14	2	Nut-Hex
8	3218-13	2	Nut-Jam
9	3253-4	2	Washer-Lock/Sp
10	321-3	4	Screw-HH
11	3217-5	2	Nut-Hex
13	72-4790	1	Battery Hold Down
14	32103-12	2	Nut-Wing
15	92-1677	1	Battery-Dry
16	56-7720	2	Post-Battery
17	46-8560	3	Screw-Flange
18	83-0840-01	1	Valve Cover Shield
19	3290-470	2	Screw-HSFH
20	61-3310	1	Plate-Logo
21	32149-7	2	Nut-Keps
22	32104-76	5	Screw-Acorn Slot
23	83-1430	1	Hose - Return Line
24	2412-34	3	Clamp-Hose
25	353-563	1	Fitting-Hydraulic, Straight
26		1	Filter & Head ASM

Ref. No.	Part No.	Qty.	Description
26:1	44-5560	1	Head-Oil Filter
26:2	72-3850	1	Seal- Oil Filter
26:4	74-3570	1	Filter
27	68-5880	1	Hose-Hydraulic
28	353-564	1	Fitting-90°
29	27-2380	2	Spacer
30	3256-23	4	Washer-Flat
31	322-4	4	Screw-HH
32	83-0830-01	1	Upper Control Panel
33	3296-16	3	Nut-Lock, NI
34	32149-2	2	Nut-Keps
35	237-143	2	O-Ring
36	93-8065	1	Decal-Traction
37	67-1300	1	Decal - Toro
38	93-7276	1	Decal - Danger
39	93-6668	1	Decal - Battery
40	92-5524	1	Decal-Noise Rating
41	63-9920	1	Decal-Noise Level
42	93-7252	1	Decal-C.e. Mark

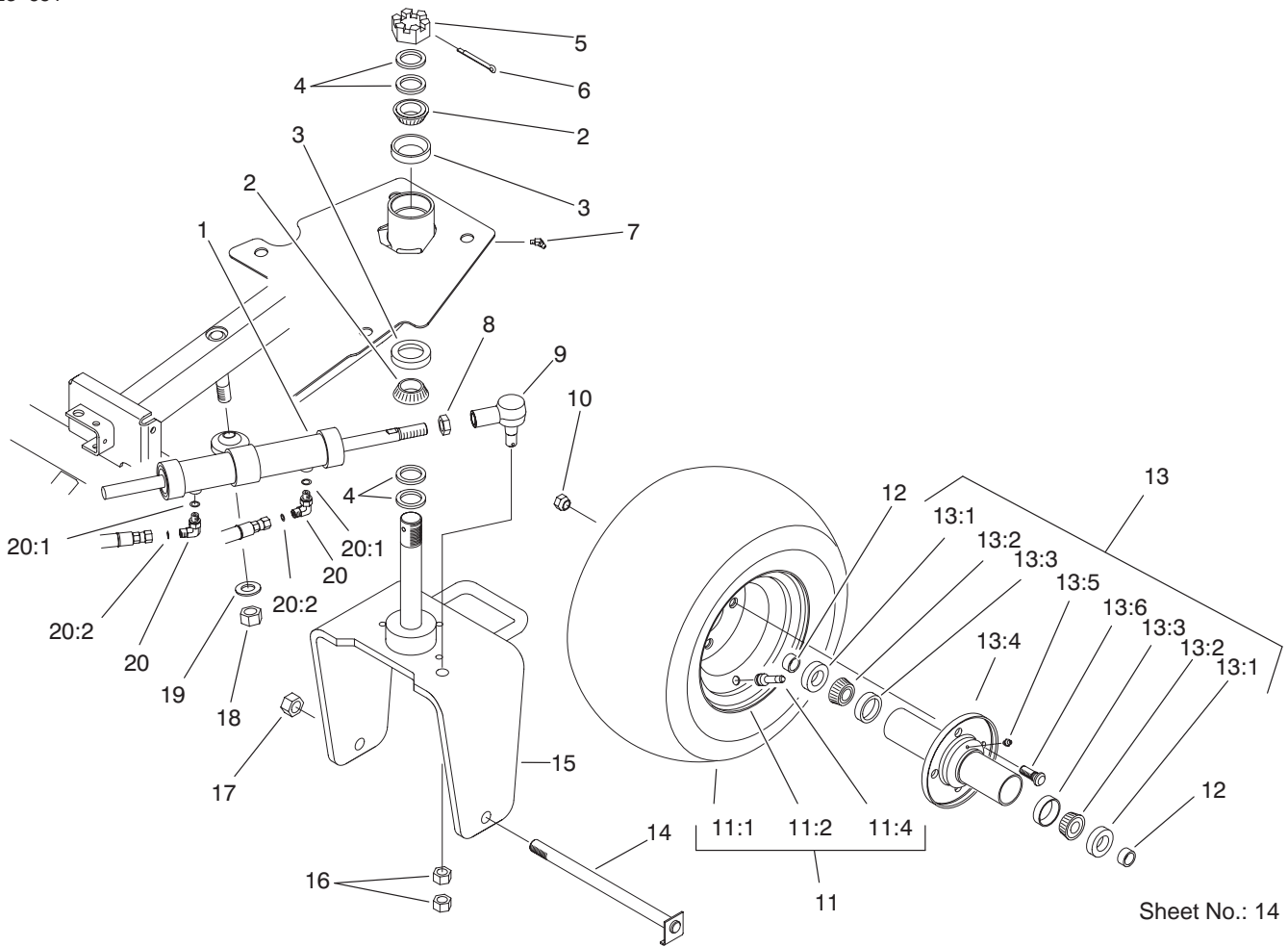

Sheet No.: 14

## Rear Wheel Assembly

Ref. No.	Part No.	Qty.	Description
1	83-2330	1	Cylinder – Steering
2	254-70	2	Cone-Bearing
3	254-61	2	Cup-Bearing
4	18-6320	4	Washer-Steering
5	32136-9	1	Nut Hex Slot
6	3272-37	1	Pin, Cotter
7	302-11	1	Fitting-Lube,45°
8	84-5300	1	Nut-Jam
9	83-1640-03	1	Rod End ASM
10	242-50	4	Nut-Lug
11		1	Wheel & Tire ASM
11:1	28-3680	1	Tire
11:2	217-60	1	Rim
11:4	232-24	1	Stem-Valve
*11:5	232-37	1	Tube
12	74-3730	2	Spacer – Rear Spindle
13		1	Hub – Sulky Tire
13:1	253-111	2	Oil Seal
13:2	254-78	2	Cone-Bearing
13:3	254-79	2	Bearing-Roller, Cup
13:4	75-9440	1	Hub ASM
13:5	302-55	1	Zerk
13:6	10-6830	4	Stud-Type, Drive
14	5-3934	1	Bolt-Caster
15	95-5952-01	1	Fork-Castor
16	3220-6	2	Nut-Jam

Ref. No.	Part No.	Qty.	Description
17	3296-67	1	Nut-Lock NI
18	3217-12	1	Nut-Hex
19	3256-28	1	Washer-Flat
20	340-132	2	90 Elbow
20:1	237-78	1	O-Ring
20:2	237-21	1	O Ring

\* Not illustrated



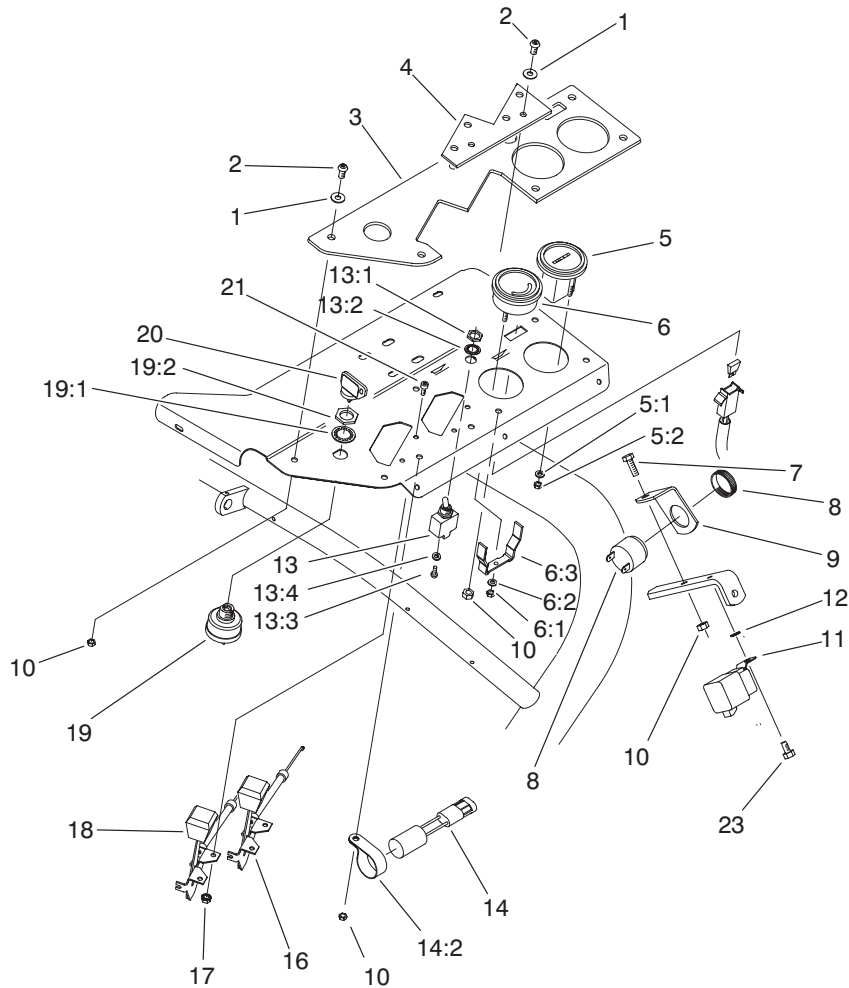

Sheet No.: 15

### Control Panel Assembly

Ref. No.	Part No.	Qty.	Description
1	3256-1	8	Washer-Flat
2	3274-69	8	Screw-HSBH
3	93-8061	1	Panel - Control
4	83-2030	1	Plate-Filler
5	66-2950	1	Guage-Hourmeter
5:1	3255-20	2	Washer-Lock, Ext. Tooth
5:2	3217-25	2	Nut-Hex
6	98-2160	1	Voltmeter
6:1	3217-27	1	Nut-Hex
6:2	3255-25	1	Washer-Lock/Ext
6:3	78-0080	1	Clamp-Mounting
7	321-4	1	Screw-HH
8	98-2159	1	Audio - Alarm
9	83-1530	1	Bracket- Buzzer Support
10	3296-16	9	Nut-Lock, NI
11	70-1480	1	Relay
12	3255-7	1	Washer-Lock/Ext
13	83-1660	1	Switch - 3 Position
13:1	218-498	2	Locknut-Hex.
13:2	218-589	1	Washer F/W
13:3	218-588	3	Screw F/W
13:4	3253-19	3	Washer-Lock/Sp
14	83-2280	1	Timer - Delay
14:1		1	Timer - Delay

Ref. No.	Part No.	Qty.	Description
14:2	98-4604	1	Clamp-R
16	83-0040	1	Control - Choke
17	3296-27	4	Nut-Lock NI
18	83-0030	1	Control - Throttle
19	88-9830	1	Switch-Ignition
19:1	3254-5	1	Washer-Lock/Int
19:2	218-461	1	Nut-HH
20	63-8360	2	Key-Ignition
21	3273-26	4	Hex Soc Screw
23	32104-95	1	Screw-HWH



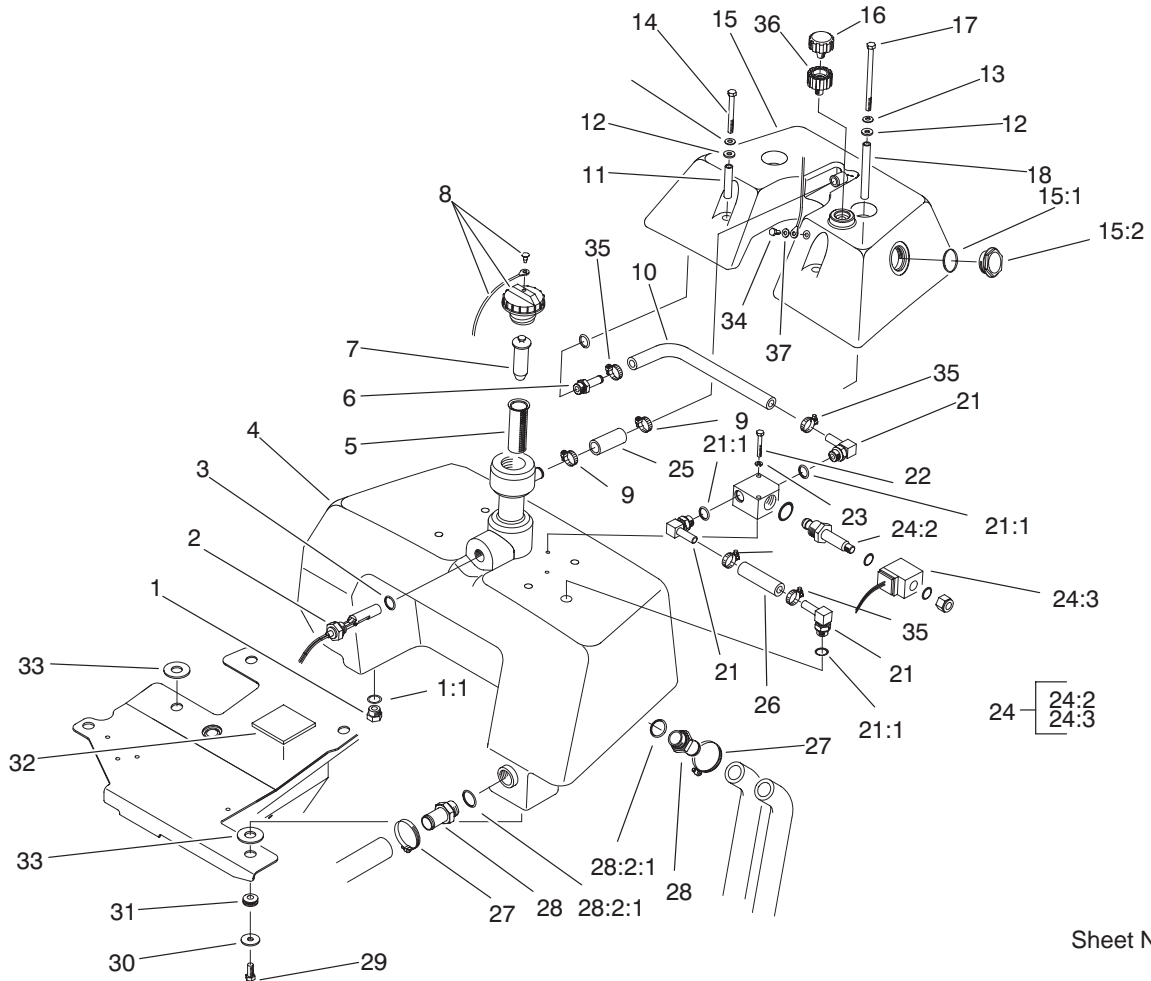

Sheet No.: 16

## Hydraulic Reservoir Assembly

Ref. No.	Part No.	Qty.	Description
1	353-550	1	Plug-Hydraulic
1:1	237-79	1	O-Ring
2	83-1450	1	Sensor-Oil Level
3	237-80	1	O-Ring
4	92-8966	1	Tank - Hyd
5	83-1520	1	Filler Screen
6	354-121	1	Fitting-Hydraulic, Straight
7	92-4063	1	Plug - Filler Cap
8	93-7160	1	Cap - Hyd Oil
9	2412-141	2	Clamp - Worm Drive
10	83-2070	1	Valve Hose
11	83-1550	2	Spacer - Tube, Short
12	83-1470	4	Washer - Neoprene
13	3256-71	4	Washer-Flat
14	322-14	2	Screw-HH
15	83-2100	1	Tank-Auxiliary, Hydraulic
15:1	94-8166	1	O-Ring
15:2	83-2250	1	Guage-Sight
16	68-6150	1	Breather-Air
17	322-29	2	Screw-HH
18	83-1560	2	Spacer - Tube, Long
21	354-120	3	Fitting-Hydraulic
21:1	237-79	2	O-Ring
22	321-11	2	Screw-HH

Ref. No.	Part No.	Qty.	Description
23	3253-3	2	Washer-Lock/Sp
24	83-1460	1	Solenoid Valve ASM
24:2	83-2000	1	Spool-Valve
24:3	83-2010	1	Coil - Valve
25	83-2090	1	Hose-Overflow
26	83-2080	1	Hose-Valve, Tank
27	2412-34	3	Clamp-Hose
28	83-0870-01	3	Fitting - Hose Barb
28:2		1	Fitting - Hose Barb
28:2:1	237-177	1	O-Ring
29	323-6	3	Screw-HH
30	63-8410	3	Washer
31	240-11	3	Grommet
32	83-2390	1	Pad - Tank
33	83-2400	2	Spacer/Washer; Tank
34	321-2	1	Screw-HH
35	2412-36	4	Clamp-Hose
36	92-8020	1	Adapter - Breather
37	3256-22	1	Washer-Flat



# Hydraulic Schematic

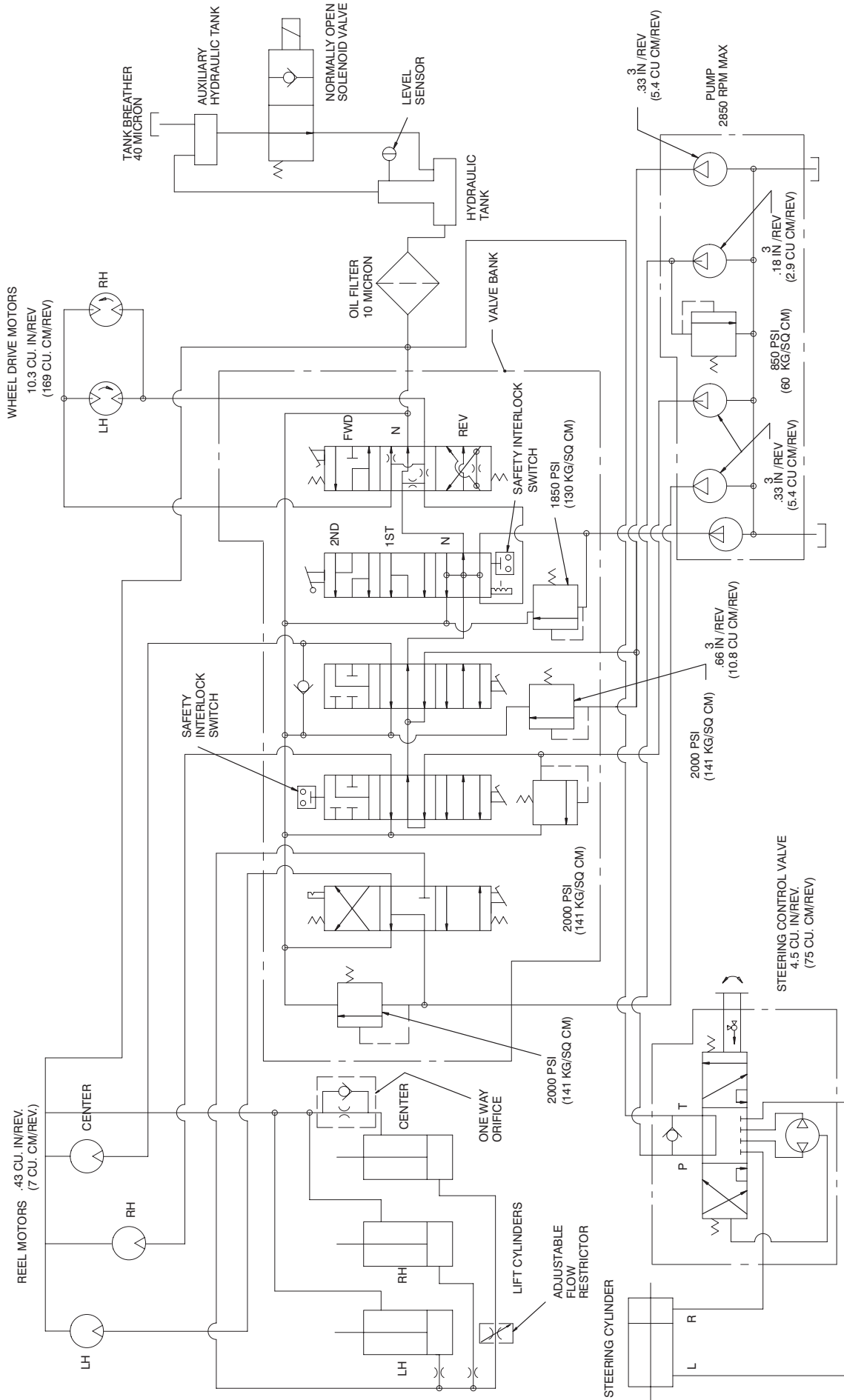





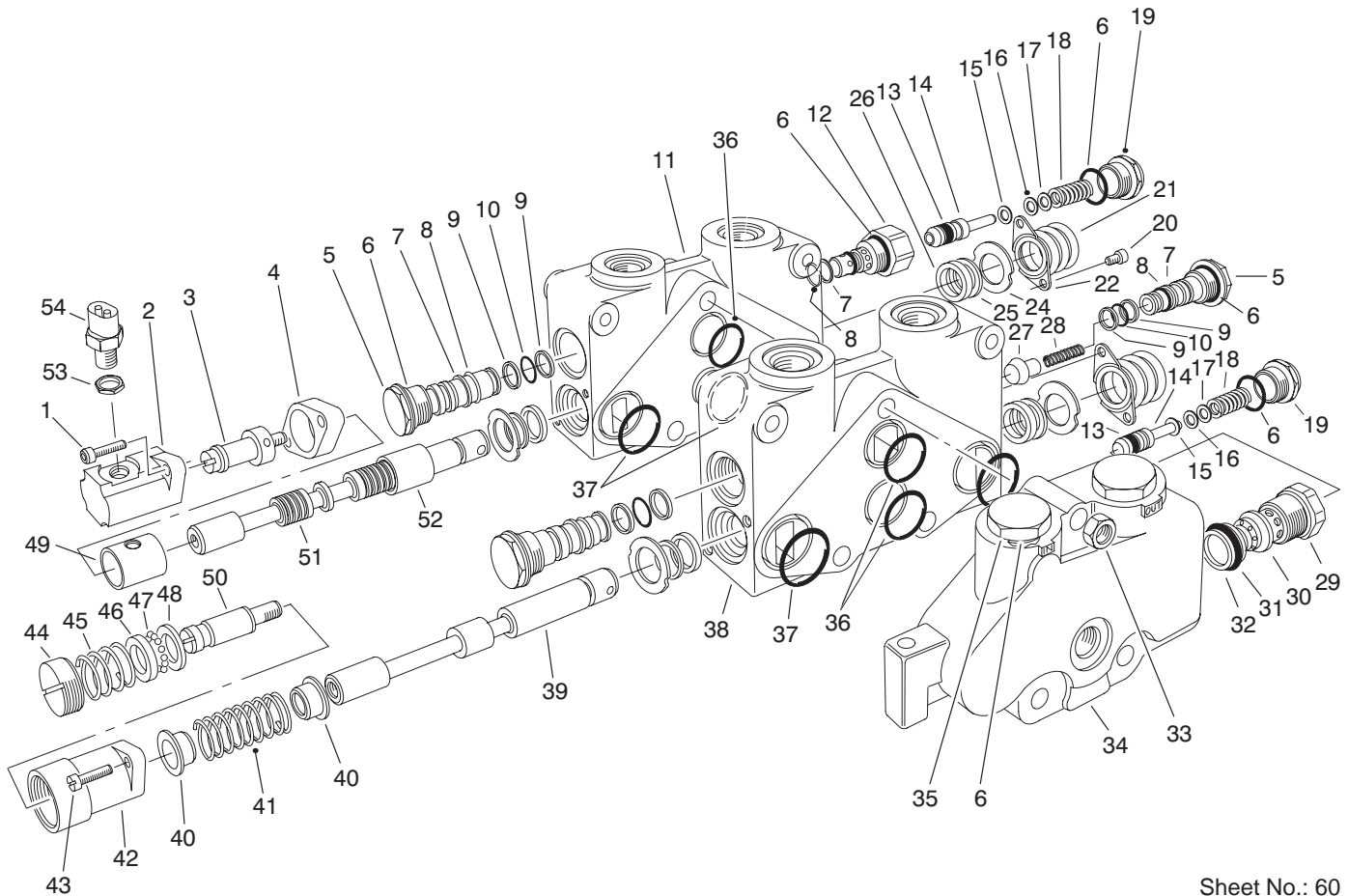

Sheet No.: 60

T-1318

## Control Valve Assembly No. 84-2203 (Sections 1&2)

Ref. No.	Part No.	Qty.	Description
1	3274-70	2	Screw-HSH
2	353-727	1	Special Bonnet
3	353-729	1	Detent Stud
4	353-733	1	Bonnet Spacer
5	353-481	3	Lift Check ASM
6	237-54	8	O Ring
7	353-306	4	Backup Washer
8	353-305	4	O Ring
9	353-303	6	Backup Washer
10	353-302	3	O Ring
12	353-851	1	Relief Body
13	353-392	2	Piston Ring
14	353-531	2	Poppet & Ring ASM
15	353-328	2	.040 Shim
16	353-329	2	.020 Shim
17	353-330	2	.010 Shim
18	353-855	2	Spring
19	353-334	2	Relief Cap
20	3274-52	4	Screw-HSH
21	353-575	2	Boot
22	93-3651	2	Retainer - Boot
24	92-2547	4	Seal - Retainer
25	92-2546	4	Wiper - Seal
26	353-957	4	Seal Cup
27	353-301	1	Poppet Lift Check
28	353-304	1	Lift Check Spring

Ref. No.	Part No.	Qty.	Description
29	353-331	1	O Ring Seal
30	353-760	1	Body Relief
31	353-758	1	O-Ring Seal
32	353-952	1	Back-Up Seal
33	3217-7	3	Nut-Hex
34	353-772	1	Left Cover
35	353-721	2	Plug
40	353-417	2	Stop Collar
41	99-6850	1	Spring-Compression
42	99-8181	1	Bonnet-R Det
43	3274-15	2	Screw-HSH
44	353-763	1	Adj Cap
45	99-1475	1	Spring - Compression
46	42-2680	1	Ball Race
47	52-5880	12	Detent Ball
48	354-29	1	Trust Plate
49	353-728	1	Sleeve
50	353-762	1	Spud - Det Out
52	353-732	1	Detent Sleeve
53	38-0410	1	Hex Nut
54	83-1890	1	Switch-Ball
55	353-766	1	Relief Cart
56	99-8182	1	Sec 1-V20c Spl ASM
57	353-837	1	Section #2
58	99-8180	1	Positioner-R Det O/Asy



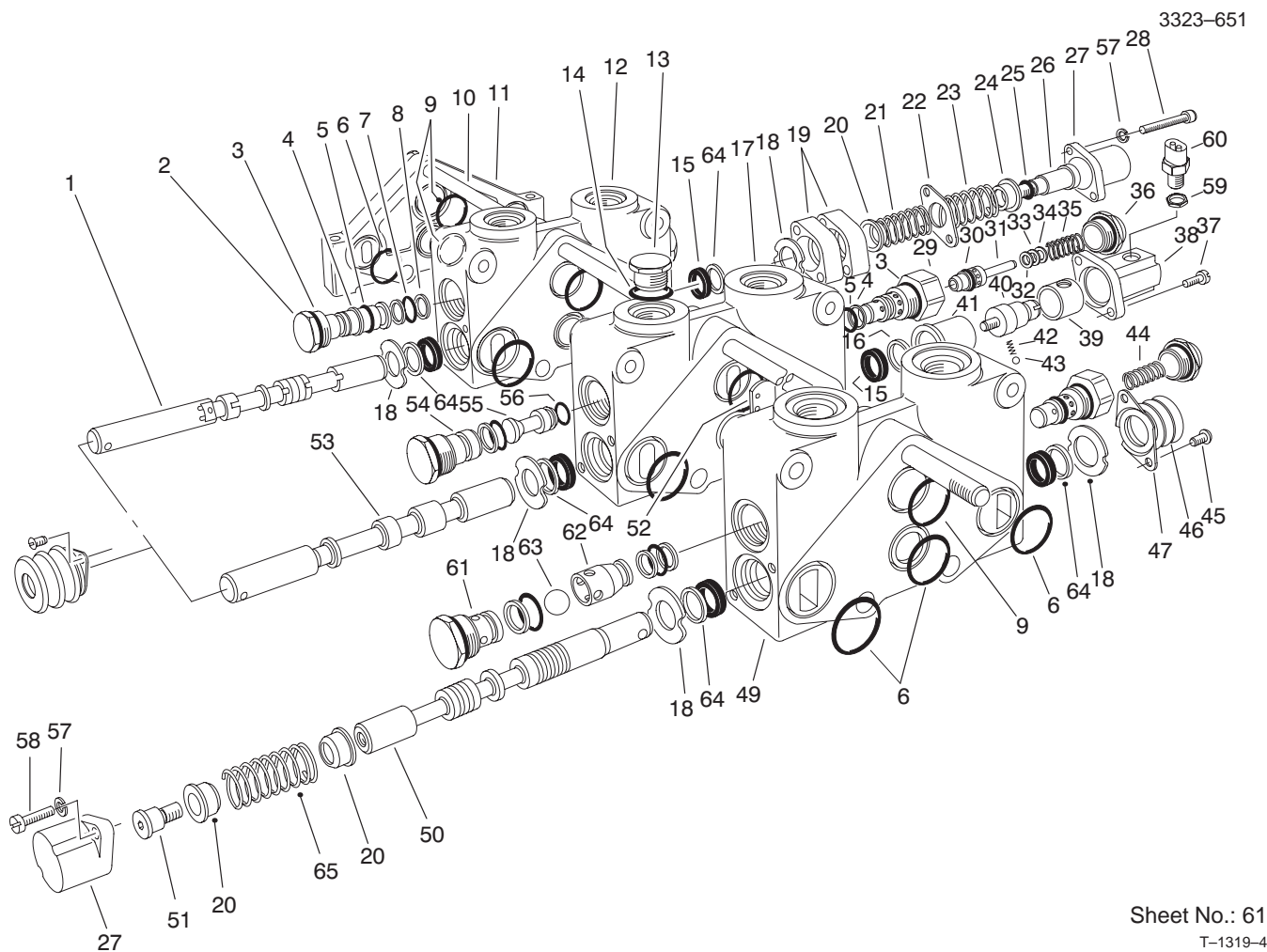

Sheet No.: 61  
T-1319-4

## Control Valve Assembly No. 84-2203 (Sections 3 Thru 5)

Ref. No.	Part No.	Qty.	Description
1	94-5434	1	Spool
2	353-481	3	Lift Check ASM
3	237-54	6	O Ring
4	353-306	5	Backup Washer
5	353-305	5	O Ring
7	353-302	3	O Ring
8	353-303	6	Backup Washer
10	353-853	3	Bolt
11	353-668	1	Cover Plate
13	353-550	1	Plug-Hydraulic
13:1	237-79	1	O-Ring
14	353-848	1	O-Ring
15	353-957	6	Seal Cup
16	353-958	1	Washer
18	92-2547	5	Seal - Retainer
19	353-733	2	Bonnet Spacer
20	353-417	3	Stop Collar
21	353-831	1	Spring
22	353-529	1	Plate - Seal Retainer
23	92-3148	1	Spring - Traction
24	353-808	1	Spring Collar
25	353-830	1	O-Ring Seal
26	94-4248	1	Spool Collar
27	99-6895	2	Bonnet
28	354-28	2	Hex Socket Screw
29	353-851	2	Relief Body

Ref. No.	Part No.	Qty.	Description
30	353-392	2	Piston Ring
31	353-531	2	Poppet & Ring ASM
32	353-328	2	.040 Shim
33	353-329	2	.020 Shim
34	353-330	2	.010 Shim
35	353-398	1	Spring
36	353-334	2	Relief Cap
37	52-5900	4	Screw
38	353-847	1	Bonnet
39	353-849	1	Sleeve
40	353-846	1	Spud
41	353-845	1	Detent Sleeve
42	353-730	1	Spring
43	353-731	1	1/4 Dia Ball
44	353-855	1	Spring
45	3274-52	6	Screw-HSH
46	353-575	3	Boot
47	93-3651	3	Retainer - Boot
51	52-5860	1	Spool Collar
52	354-122	1	Spool #4
54	353-953	1	Plug ASM
55	353-844	1	Plug
56	353-850	1	O-Ring Seal
57	3253-3	4	Washer-Lock/Sp
58	3274-84	4	Screw-HSH
59	38-0410	1	Hex Nut



# SPECIAL TOOLS

## REEL MOTOR SEAL INSTALLATION TOOLS

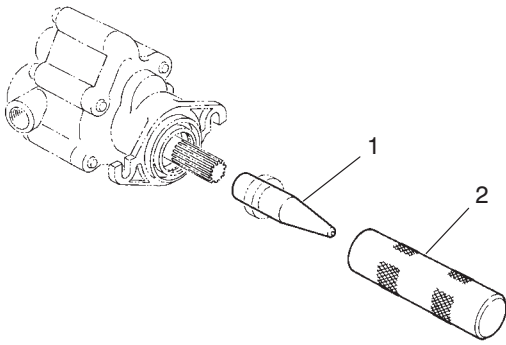

T-0727

Ref. No.	Part No.	Description	No. Used
1	TOR491430	Protector – Seal	1
2	TOR491450	Installer – Seal	1

## BED KNIFE SCREW TOOL NO. TOR510880

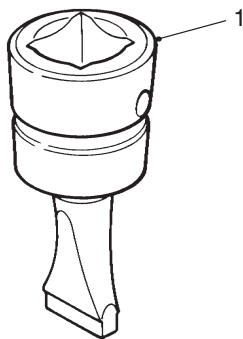

T-0729

Ref. No.	Part No.	Description	No. Used
1		Tool – Bed Knife Screw	1

## BEARING REPLACEMENT TOOL KIT NO. TOR238900

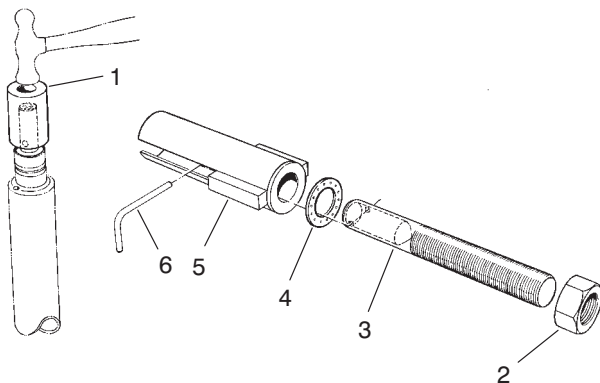

T-0730

Ref. No.	Part No.	Description	No. Used
1	23-8880	Driver – Bearing	2
2	3219-18	Nut – Hex.	1
3	23-8840	Puller – Bolt	1
4	22-6090	Washer – Thrust	1
5	23-8850	Tube – Support	1
6	23-8860	Pin – Bearing Rplcmnt.	1

## BACKLAPPING BRUSH ASSEMBLY NO. 29-9100

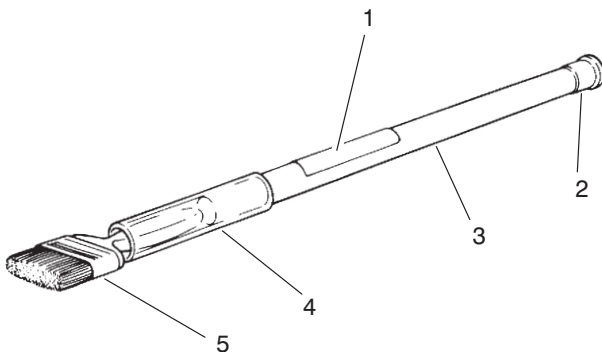

T-0731

Ref. No.	Part No.	Description	No. Used
1	12-9140	Decal	1
2	2410-18	Plug	1
3	29-9080	Handle	1
4	29-9090	Hose – Handle	1
5	36-4310	Brush	1

Note: Special tools may be ordered from: Owatonna Tool Company 2013 4th St. NW Owatonna, MN 55060

# SPECIAL TOOLS (Continued)

## ALIGNMENT TOOL NO. TOR200120

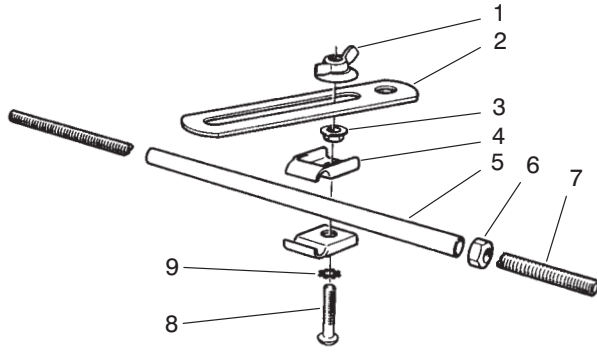

T-0732

Ref. No.	Part No.	Description	No. Used
1	3-4808	Nut - Wing	1
2	20-0110	Bracket - Alignment	1
3	32128-20	Nut - Lock, Flange	1
4	3-6657	Clip - Skid	2
5	20-0070	Tube	1
6	3219-2	Nut - Hex.	1
7	20-0080	Rod	1
8	32122-35	Screw - Truss Head	1
9	3255-8	Washer - Lock, Int. Tooth	1

**Note: Special tools may be ordered from: Owatonna Tool Company  
2013 4th St. NW  
Owatonna, MN 55060**

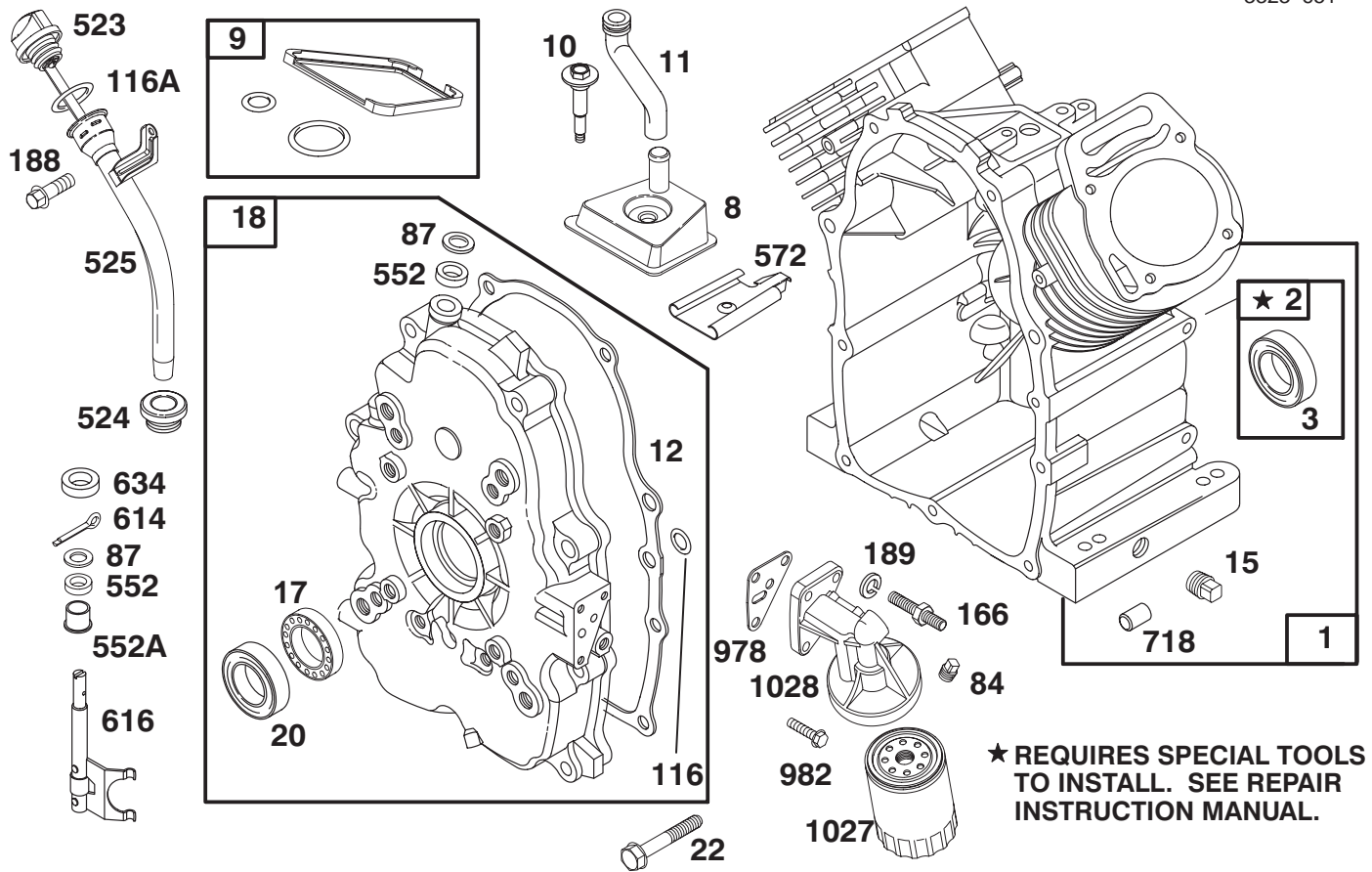

Assemblies include all parts shown in frames.

Sheet No.:  
T-xxxx

## Engine Briggs & Stratton Model 303447-1179-E1

Ref. No.	Part No.	Qty.	Description
1	808440	1	Cylinder Assembly
2	808534	1	Bearing-Cylinder
*3	805101	1	Seal - Oil
8	807795	1	Breather Assembly
*9	807688	1	Gasket - Breather
10	805751	1	Screw - Hex.Washer Head
11	806083	1	Tube - Breather
12	806190	1	Gasket - Crankcase Cover
15	805048	1	Plug - Oil Drain
17	805754	1	Bearing - Ball
18	808502	1	Cover Assy. - Crankcase
*20	805049	1	Seal - Oil
22	805696	1	Screw - Crankcase Cover
84	91488	1	Plug - Pipe
*87	805054	1	Seal - Governor Shaft
116	806191	1	O-Ring (Crankcase Cover)
*116A	805386	1	O Ring (Dipstick)
166	805073	1	Stud - Oil Filter Adapter
188	805247	1	Screw - Hex. Head
189	805449	1	Lockwasher

Ref. No.	Part No.	Qty.	Description
523	807977	1	Dipstick
*524	281370	1	Seal - Fill Tube
525	807584	1	Tube - Oil Fill
552	805412	1	Bushing - Governor Shaft
552A	805413	1	Bushing - Governor Shaft
572	805197	1	Baffle - Breather
614	806096	1	Pin - Cotter
616	807596	1	Fork - Governor
634	805416	1	Washer - Governor Shaft
718	805103	1	Dowel - Crankcase
*978	805250	1	Gasket - Oil Filter Adapter
982	805030	1	Screw
1027	492932	1	Filter - Oil
1028	808325	1	Adapter - Oil Filter
1058	273685	1	Owner's Manual

\*Included in Gasket Set - Part No. 808390.

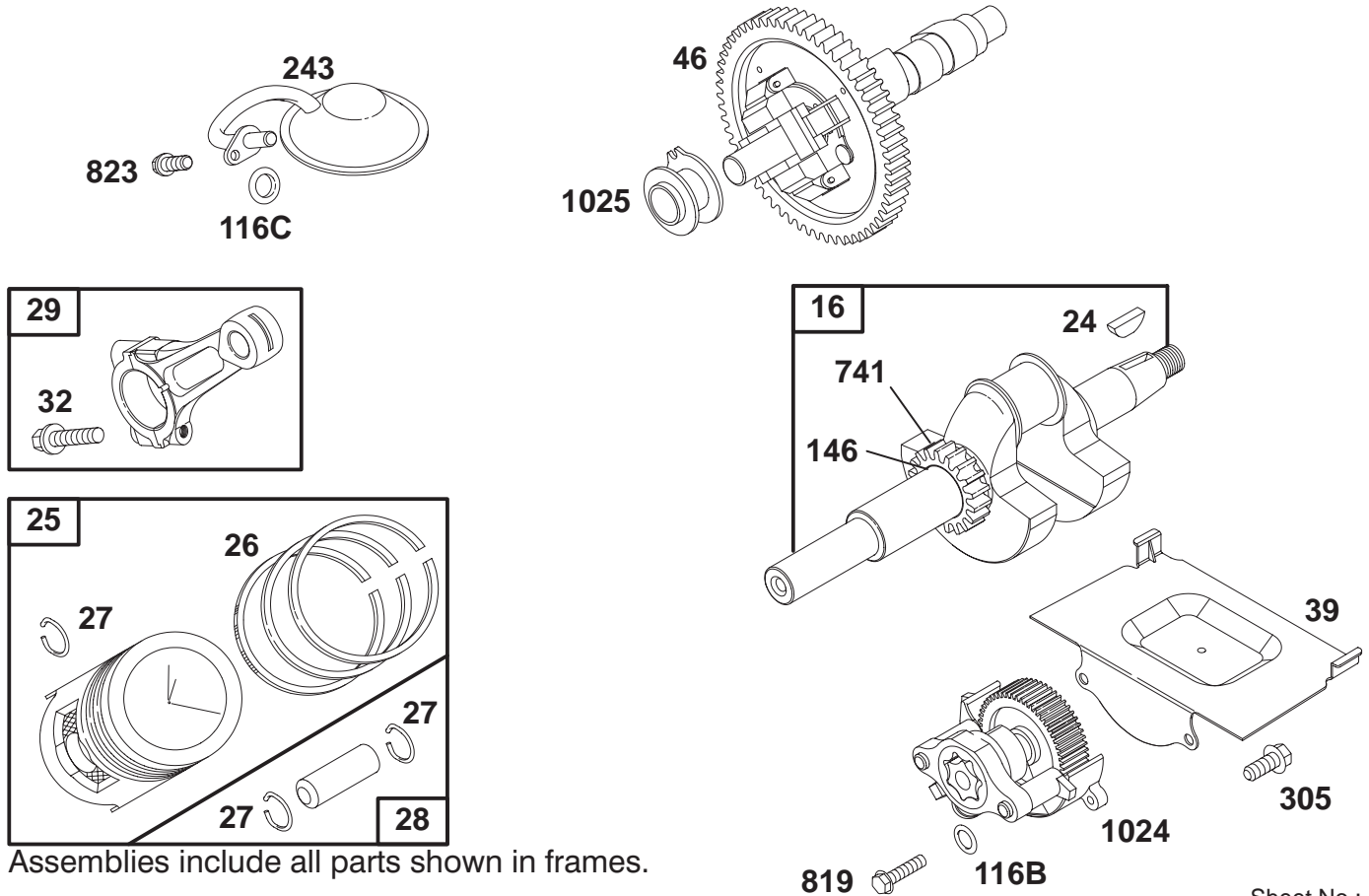

Sheet No.:  
T-xxxx

## Engine Briggs & Stratton Model 303447-1179-E1

Ref. No.	Part No.	Qty.	Description
16	808417	1	Crankshaft
24	806066	1	Key – Flywheel
25	807619	1	Piston Assembly (Standard)
	807807	1	Piston Assembly (.010 O.S.)
	807809	1	Piston Assembly (.020 O.S.)
	807811	1	Piston Assembly (.030 O.S.)
26	807620	1	Ring Set – Piston (Standard)
	807808	1	Ring Set – Piston (.010 O.S.)
	807810	1	Ring Set – Piston (.020 O.S.)
	807812	1	Ring Set – Piston (.030 O.S.)
27	805099	1	Lock – Piston Pin
28	807621	1	Piston Pin Assembly
29	807900	1	Connecting Rod Assembly
	807809	1	Rod – Connecting (.020 U.S.)
32	805395	1	Screw – Connecting Rod

Ref. No.	Part No.	Qty.	Description
39	805654	1	Deflector – Oil
46	807542	1	Gear – Cam
*116B	805058	1	O-Ring (Oil Pump)
*116C	805316	1	O-Ring (Pick – Up Tube)
146	94196	1	Key – Timing
243	807598	1	Screen – Oil Pump Pick-Up
305	805406	1	Screw
741	805984	1	Gear – Timing
819	805057	1	Screw
823	805317	1	Screw – Mounting
1024	807644	1	Oil Pump Assembly
1025	805313	1	Slider – Governor

\*Included in Gasket Set – Part No. 808390.

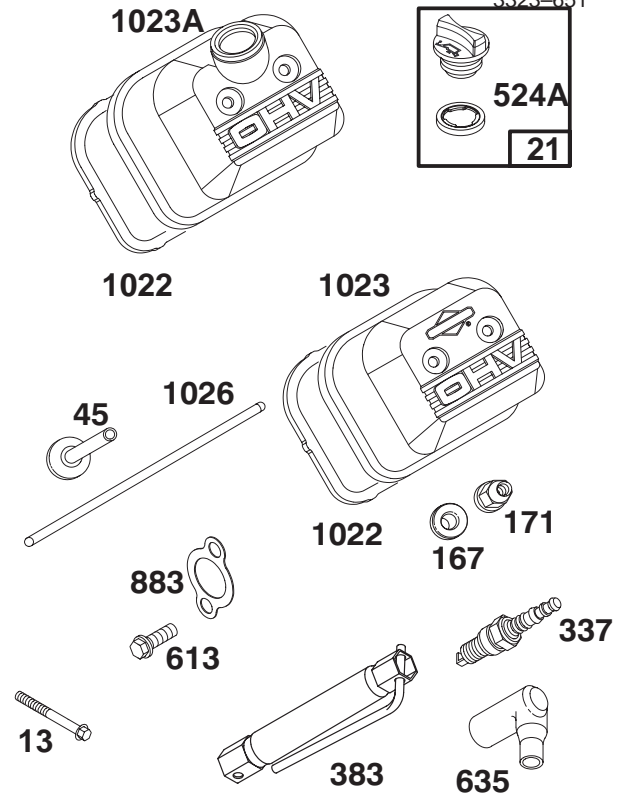
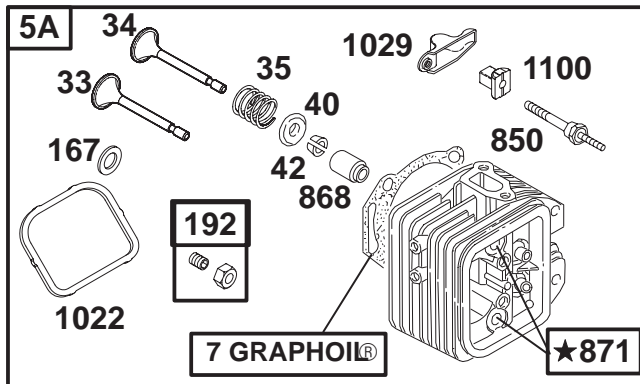
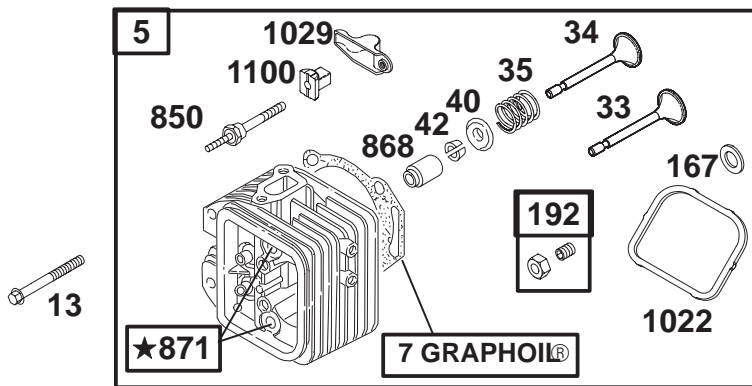

★ REQUIRES SPECIAL TOOLS TO INSTALL. SEE REPAIR INSTRUCTION MANUAL.

Assemblies include all parts shown in frames.

Sheet No.: T-xxxx

## Engine Briggs & Stratton Model 303447-1179-E1

Ref. No.	Part No.	Qty.	Description
5	808381	1	Head – Cylinder (Cyl. #1)
5A	808382	1	Head – Cylinder (Cyl. #2)
*‡7	806085	1	Gasket – Cylinder Head
13	805097	1	Screw – Cylinder Head
21	491832	1	Plug – Oil Filler
33	807681	1	Valve – Exhaust
34	807680	1	Valve – Intake
35	805937	1	Spring – Valve
40	805092	1	Retainer – Valve Spring
42	807683	1	Retainer – Valve
45	262679	1	Tappet – Valve
*‡167	805420	1	Washer – Valve Cover
‡171	805019	1	Nut – Nylock
192	807623	1	Screw – Valve Adjustment
337	496018	1	Plug – Spark
383	19374	1	Wrench – Spark Plug
*‡524A	271983	1	Seal – Filler Plug
613	805158	1	Screw – Hex.
635	805529	1	Elbow – Spark Plug
868	805094	1	Seal – Valve Guide
871	805084	1	Guide – Valve
*‡883	805024	1	Gasket – Exhaust

Ref. No.	Part No.	Qty.	Description
			Manifold
850	806037	1	Stud – Rocker Arm
*‡1022	806039	1	Gasket – Valve Cover
1023	805100	1	Cover – Valve
1023A	808032	1	Cover – Valve
1026	805352	1	Rod – Push (Intake Valve) Note: 805617 Rod – Push (Exhaust Valve)
1029	806036	1	Arm – Rocker
1100	806038	1	Pivot – Rocker Arm

\*Included in Gasket Set – Part No. 808390.

‡Included in Valve Overhaul Kit – Part No. 808392.

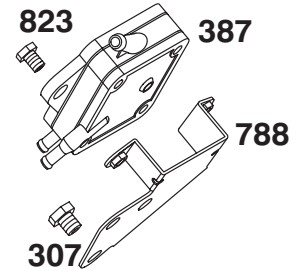
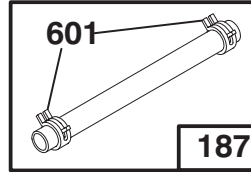
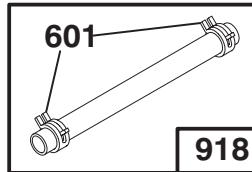
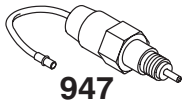
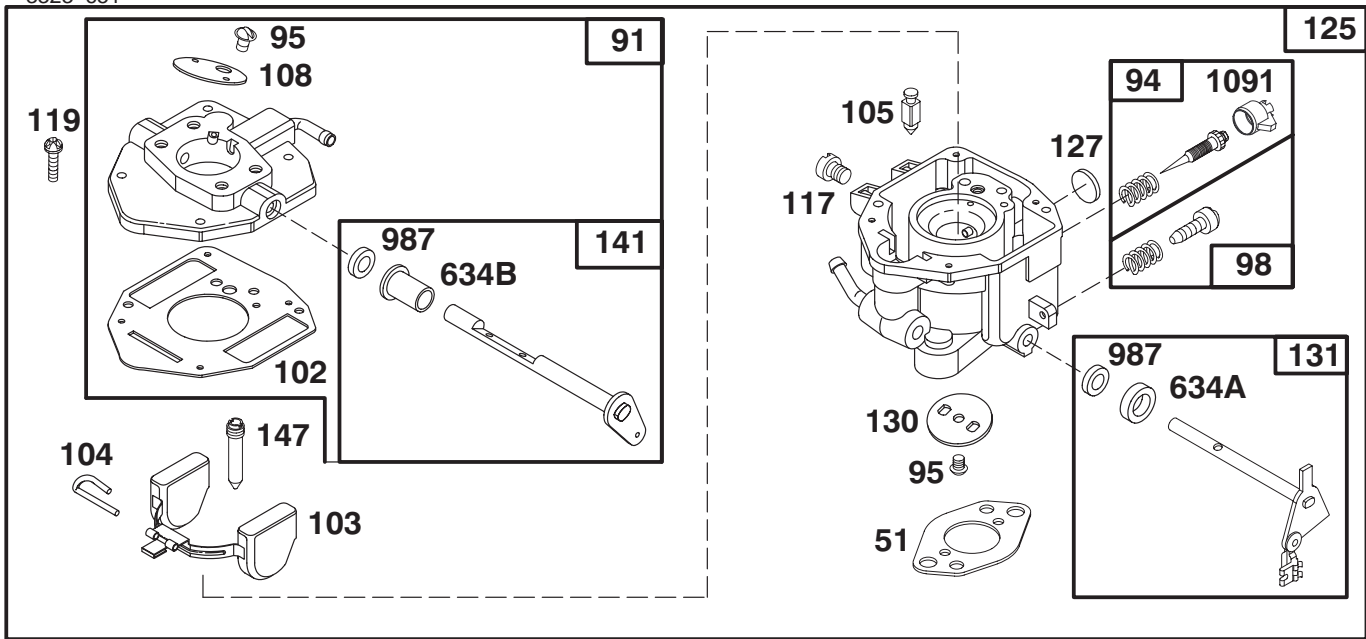

Assemblies include all parts shown in frames.

Sheet No.:  
T-xxxx

## Engine Briggs & Stratton Model 303447-1179-E1

Ref. No.	Part No.	Qty.	Description
*51	805700	1	Gasket – Carburetor Mtg.
91	807919	1	Body – Upper Carburetor
95	805538	1	Screw – Valve Mtg.
98	808177	1	Screw – Throttle Adj.
†102	805541	1	Gasket – Carburetor Body
103	805546	1	Float Assembly
†104	805545	1	Pin – Float Hinge
†105	805547	1	Valve – Fuel Inlet
108	805539	1	Valve – Choke
117	805852	1	Jet – Main
	805537	1	Jet – Main (High Altitude)
†94	808257	1	Valve – Idle Adjust
119	805540	1	Screw – Upper Body Mtg.
125	808251	1	Carburetor Assembly
†127	805559	1	Plug – Welch
130	805554	1	Valve – Throttle
131	807720	1	Shaft – Throttle
141	807722	1	Shaft – Choke
†147	805553	1	Jet – Slow Speed
187	296004	1	Line – Fuel (Cut to Required

Ref. No.	Part No.	Qty.	Description
			Length)
307	805025	1	Screw – Hex. Hd.
387	491922	1	Pump – Fuel
601	93053	1	Clamp – Hose
†634A	805557	1	Collar – Throttle
†634B	805543	1	Collar – Choke
788	807685	1	Bracket – Fuel Pump
823	805317	1	Screw – Mounting
918	393815	1	Line – Vacuum (Cut to Required Length)
947	807664	1	Solenoid
†987	805544	1	Seal – Shaft
1091	805862	1	Cap – Limiter

\*Included in Gasket Set – Part No. 808390.

†Included in Carburetor Kit – Part No. 808273.

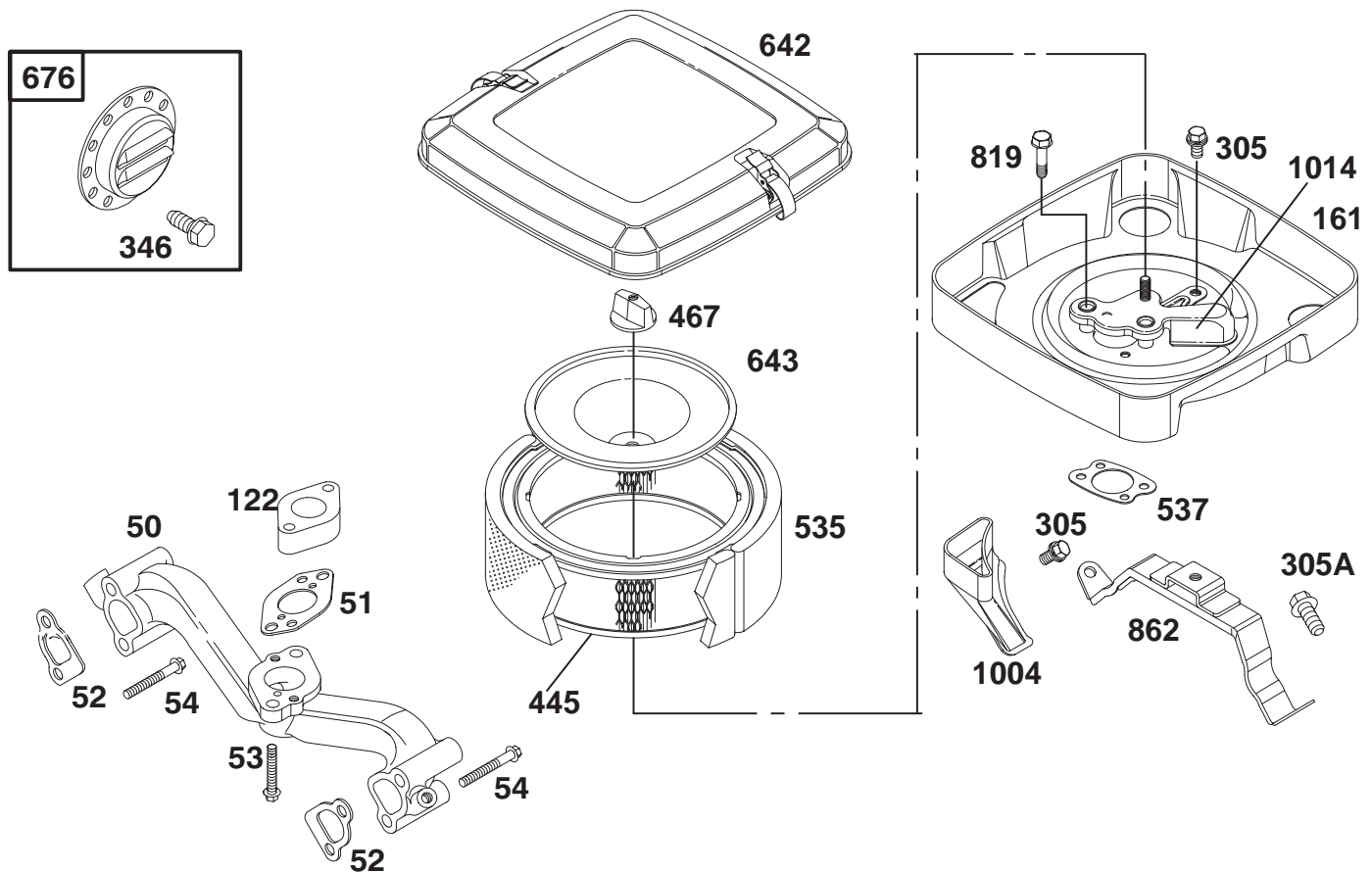

Sheet No.:

T-xxxx

## Engine Briggs & Stratton Model 303447-1179-E1

Ref. No.	Part No.	Qty.	Description	Ref. No.	Part No.	Qty.	Description
50	805772	1	Manifold – Intake	1014	807797	1	Shield – Carburetor
*51	805700	1	Gasket – Carburetor Mtg.				
*‡52	805023	1	Gasket – Intake Manifold				
53	805466	1	Screw				
54	805006	1	Screw				
122	805328	1	Spacer – Carburetor				
161	807857	1	Base – Air Cleaner				
305	805406	1	Screw – Hex. (M6 x 12mm)				
305A	805902	1	Screw – Hex. (M6 x 16mm)				
346	94896	1	Screw – Hex.				
445	394018	1	Filter– Air				
467	491875	1	Knob – Air Cleaner				
535	272490	1	Filter– Air				
*537	805655	1	Gasket – Air Cleaner				
642	807862	1	Cover – Air Cleaner				
643	805631	1	Plate – Air Cleaner				
676	397630	1	Deflector – Muffler				
819	805057	1	Screw – Hex. Hd.				
862	807796	1	Bracket – Air Cleaner				
1004	805632	1	Strap – Cleaner Mounting				

\*Included in Gasket Set – Part No. 808390.

‡Included in Valve Overhaul Kit – Part No. 808392.

















