



44" Two Stage Snowthrower

For Garden Tractors

Model No. 79366-20000001 and Up

Parts Catalog

Ordering Replacement Parts

To order replacement parts, please supply: the part number, the quantity, and the description of each part desired.

Understanding Reference Numbers

Each identified part in an illustration has a reference number. The reference number for a part also appears in the parts list, along with other information about the part.

This catalog uses two special reference number formats, one to indicate parts in a service assembly and another to indicate the quantity of a given part in an illustration.

Service Assembly Reference Numbers

Parts in service assemblies have reference numbers in the form **a:b**. The **a** represents the reference number of the entire service assembly and the **b** represents a sequential number unique to each part within the service assembly.

For example, a wheel assembly might be identified by reference number **6**, the tire by **6:1**, the valve by **6:2**, and the wheel by **6:3**. When you order the assembly identified by reference number **6**, you receive all parts identified by reference numbers **6:1**, **6:2**, and **6:3**. However, you may also order any part individually.

Reference numbers of this type appear in illustrations and in part lists.

Reference Numbers Indicating Quantity

In an illustration, if a reference number indicates more than one part, the reference number has the form **nX y**. The **n** represents the quantity of the part, the **X** is the multiplication symbol, and the **y** represents the reference number.

For example, in an illustration, the reference number **2X 37** means that two of the parts identified by reference number **37** are indicated.

Contents

Description	Page	Description	Page
Discharge Chute Assembly	3	Pully Box Assembly	6
Jack Shaft Assembly	4	Crank Assembly	7
Worm Gear Assembly	5		

Part Description Abbreviations

Part descriptions in this catalog may include the following abbreviations.

Abbreviation	Meaning	Abbreviation	Meaning
AR	as required	INC	incorporated
ASM	assembly	LH	left hand
CARR	carriage	NI	nylon insert
DEG	degrees	PPH	Phillips pan head
FH	flat head	PTH	Phillips truss head
GA	gauge	PTO	power take off
HF	hex flange	RH	right hand
HH	hex head	SFH	slotted fillister head
HHF	hex head flange	SHH	slotted hex head
HLH	hex lag head	SQH	square head
HJ	hex jam	SHWH	slotted hex washer head
HOC	height-of-cut	SPH	slotted pan head
HS	hex socket	SRH	slotted round head
HSBH	hex socket button head	STD	standard
HSFH	hex socket flat head	TAP	self tapping
HSH	hex socket head	TTH	Torx truss head
HWH	hex washer head	WH	wing head
HWHTF	hex washer head thread forming		

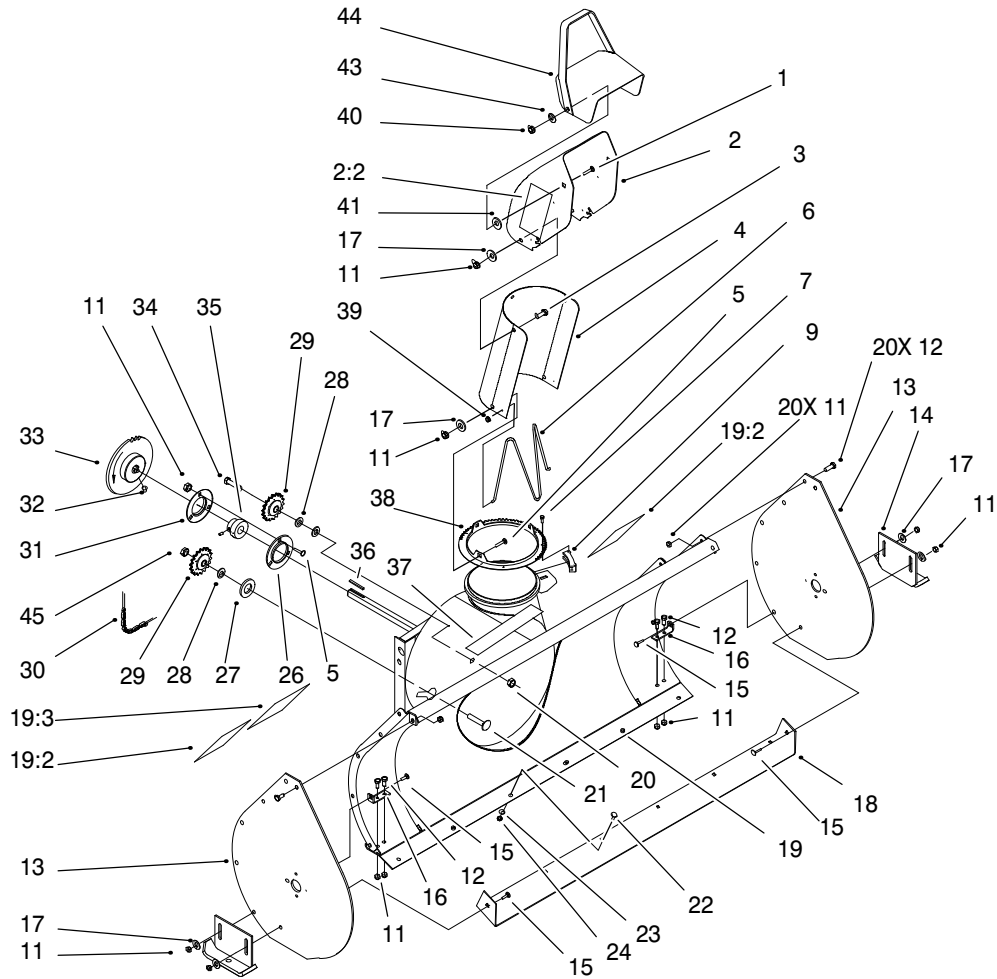

Sheet No.:2

Discharge Chute Assembly

Ref. No.	Part No.	Qty.	Description
1	3231-2	2	Screw-CARR
2	94-1832	1	Chute
2:2	94-8079	1	Decal-Danger
3	322-2	3	Screw-HH
4	26-1110-01	1	Extender-Chute, Upper
5	3230-1	3	Screw-CARR
6	12-2040	1	Wire-Chute
7	27-0220	6	Screw-Special
9	25-5450	3	Retainer-Chute
11	3296-29	37	Nut-Lock
12	322-3	24	Screw-HH
13	57-3510-01	2	Plate-Side
14	78-0800-01	2	Support-Skid
15	3230-2	4	Screw-CARR
16	99-2304	2	Bracket-Blade, Support
17	3256-23	10	Washer-Flat
18	99-2303-01	1	Blade-Scraper
19	100-8027	1	Auger Housing ASM
19:2	63-2380	2	Decal-Danger
19:3	92-8652	1	Decal-Warning
20	3218-5	1	Nut-Jam
21	3233-4	1	Screw-CARR
22	3229-25	6	Screw-CARR
23	3256-22	6	Washer-Flat

Ref. No.	Part No.	Qty.	Description
24	3296-42	6	Nut-Lock
26	110568	1	Flange
27	3256-28	1	Washer-Flat
28	3256-26	3	Washer-Flat
29	93-1614-01	2	Sprocket-Idler
30	98-3098	1	Chain-Drive
31	119020	1	Flange-Relube Zerk
32	909546	2	Screw-SQH Set
33	95-3867-01	1	Sprocket-38 T
34	325-7	1	Screw-HH
35	110569	1	Bearing & Collar
36	6366	1	Key
37	92-8748	1	Decal-Attachment
38	25-5290-01	1	Ring-Chute, Swivel
39	3290-326	2	Nut-Push
40	3296-39	2	Nut-Lock, NI
41	20-4320	2	Washer-Rubber
43	3290-340	2	Washer-Belleville
44	11-7120-01	1	Deflector
45	3296-23	1	Nut-Lock, NI

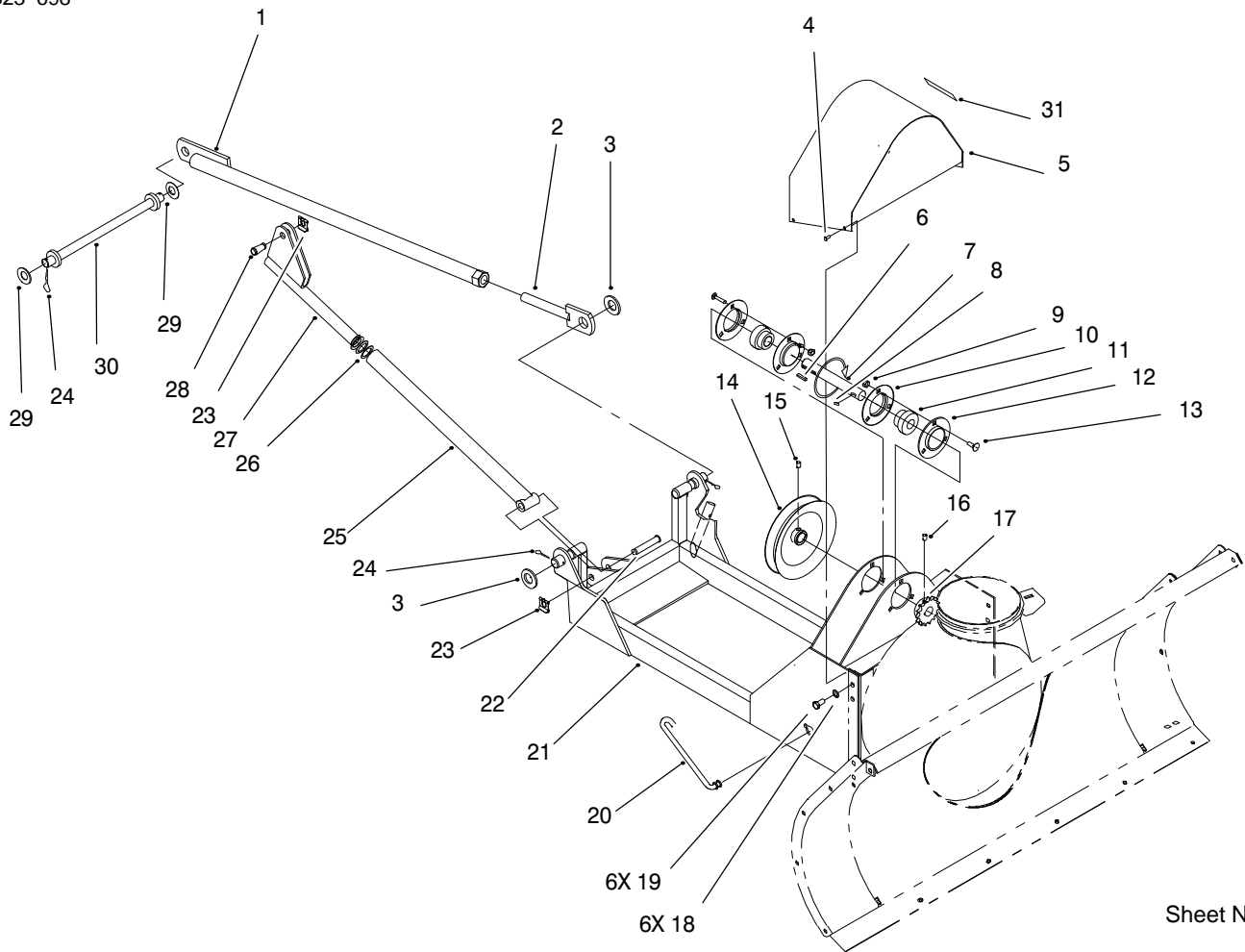

Sheet No.:3

Jack Shaft Assembly

Ref. No.	Part No.	Qty.	Description
1	95-3999-01	2	Brace ASM
2	95-4023-01	2	Adjuster ASM
3	3256-29	2	Washer-Flat
4	32144-1	4	Screw-Taptite
5	95-3859-01	1	Pulley Cover ASM
6	6366	1	Key
7	95-3836-01	1	Shaft-Jack
8	937221	1	Key-Hi Pro
9	3296-29	6	Nut-Lock
10	119020	2	Flange-Relube Zerk
11	110569	2	Bearing & Collar
12	110568	2	Flange
13	3230-1	6	Screw-CARR
14	94-7841	1	Pulley-Drive
15	3242-2	2	Screw-SQH
16	3241-5	2	Screw-Set
17	117338	1	Sprocket-15 T
18	3253-5	6	Washer-Lock/Sp
19	323-4	6	Screw-HH
20	99-6455	1	Link-Spring Tension
21	95-3848-01	1	Frame ASM
22	98-1640	1	Pin-Clevis
23	95-4064	2	Clip-Pin
24	9335064	4	Pin-Hair
25	100-5022-01	1	Rod-Lift
26	3256-62	3	Washer-Flat

Ref. No.	Part No.	Qty.	Description
27	94-7671-01	1	Yoke
28	98-1639	1	Pin-Clevis
29	3256-28	2	Washer-Flat
30	95-3993-01	1	Link ASM
31	98-8705	1	Decal-Important

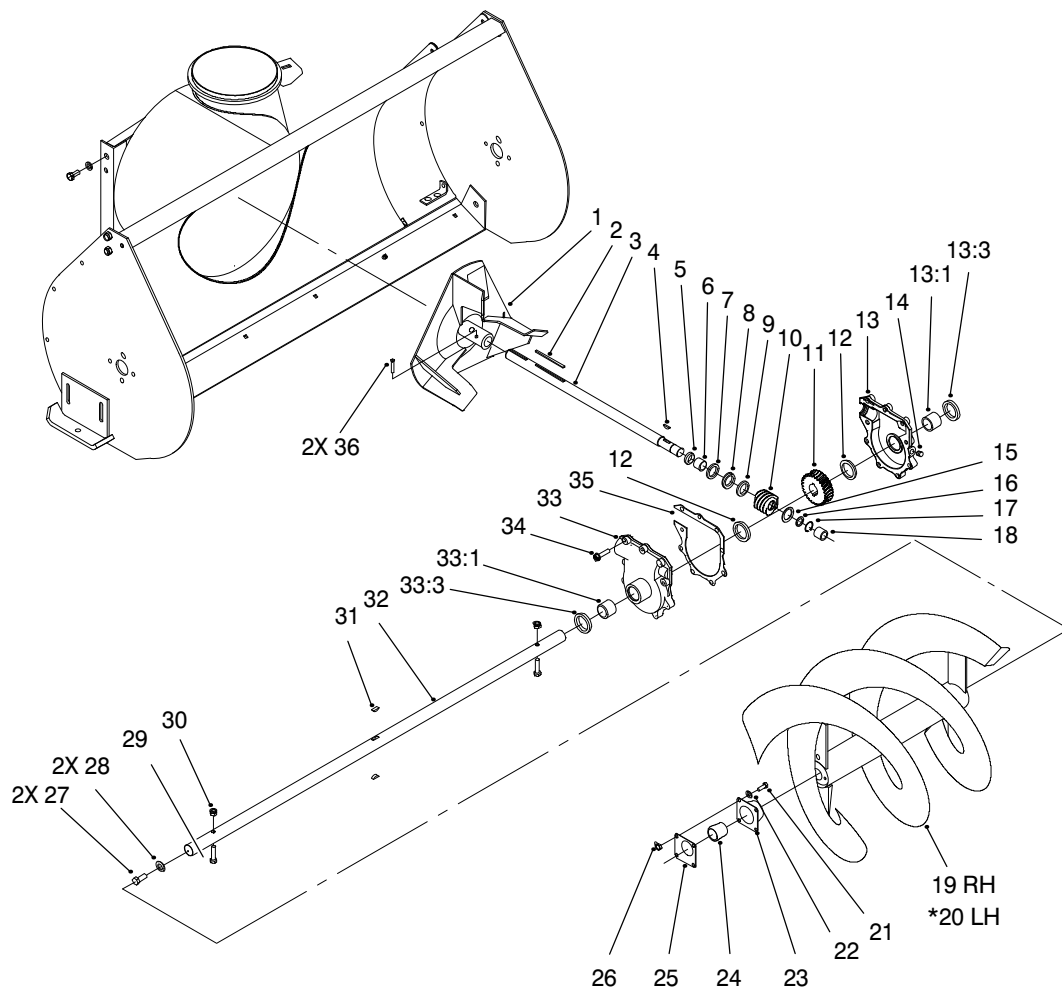

Sheet No.:4

Worm Gear Assembly

Ref. No.	Part No.	Qty.	Description
1	19-8890-01	1	Impeller
2	6-8590	1	Key
3	19-8540	1	Shaft-Impeller
4	3257-23	1	Key-Woodruff
5	237-87	1	Ring-Quad
6	20-3210	1	Bushing-Special
7	252-78	1	Bearing-Thrust
8	252-76	1	Bearing-Thrust
9	252-77	1	Thrust-Washer
10	5-7170	1	Gear
11	5-7180	1	Gear-Worm 21 T
12	252-71	2	Bearing-Thrust
13	37-8860	1	LH Gear Case/Bushing ASM
13:1	256-237	1	Bushing
13:3	7-0045	1	Seal-Oil
14	281-1	1	Plug-SQH Pipe
15	3-8664	1	Washer-Thrust
16	5210	1	Washer-Shim
17	32120-72	1	Ring-Snap
18	256-32	1	Bushing
19	57-3300-01	1	Auger, RH
*20	57-3370-01	1	Auger, LH
21	321-4	8	Screw-HH
22	3256-22	8	Washer-Flat
23	20-0990	2	Bearing-Flange, Front

Ref. No.	Part No.	Qty.	Description
24	20-0980	2	Bearing
25	20-1000	2	Bearing-Flange, Rear
26	3296-42	8	Nut-Lock
27	3235-22	2	Screw-HH
28	2844	2	Washer
29	322-14	2	Screw-HH
30	3296-29	2	Nut-Lock
31	3257-33	2	Key-Woodruff
32	57-3500	1	Shaft-Auger
33	37-8850	1	RH Gear Case/Bushing ASM
33:1	256-237	1	Bushing
33:3	7-0045	1	Seal-Oil
34	32144-41	8	Screw-Taptite
35	92-9839	1	Gasket-Gear Box
36	3242-6	2	Screw-SQH Set

* Not illustrated

