



ProLine Mid-Size

17 HP Traction Unit

30169—200000001 & Up

Operator's Manual

Introduction

Thank you for purchasing a Toro product.

All of us at Toro want you to be completely satisfied with your new product, so feel free to contact your local Authorized Service Dealer for help with service, genuine replacement parts, or other information you may require.

Whenever you contact your Authorized Service Dealer or the factory, always know the model and serial numbers of your product. These numbers will help the Service Dealer or Service Representative provide exact information about your specific product. You will find the model and serial number plate located in a unique place on the product as shown below.

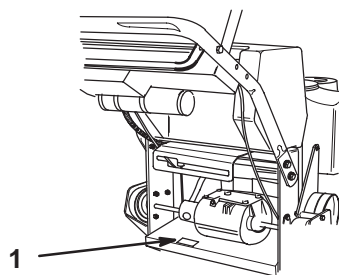

1. Model and Serial Number Plate

m-4189

For your convenience, write the product model and serial numbers in the space below.

Model No: _____
Serial No. _____

Read this manual carefully to learn how to operate and maintain your product correctly. Reading this manual will help you and others avoid personal injury and damage to the product. Although we design, produce and market safe, state-of-the-art products, you are responsible for using the product properly and safely. You are also responsible for training persons, who you allow to use the product, about safe operation.

The warning system in this manual identifies potential hazards and has special safety messages that help you and others avoid personal injury, even death. DANGER, WARNING and CAUTION are signal words used to identify the level of hazard. However, regardless of the hazard, be extremely careful.

DANGER signals an extreme hazard that will cause serious injury or death if the recommended precautions are not followed.

WARNING signals a hazard that may cause serious injury or death if the recommended precautions are not followed.

CAUTION signals a hazard that may cause minor or moderate injury if the recommended precautions are not followed.

Two other words are also used to highlight information. “Important” calls attention to special mechanical information and “Note” emphasizes general information worthy of special attention.

The left and right side of the machine is determined from the normal operator’s position.



WARNING:



The engine exhaust from this product contains chemicals known to the State of California to cause cancer, birth defects, or other reproductive harm.

IMPORTANT: This engine is not equipped with a spark arrester muffler. It is a violation of California Public Resource Code Section 4442 to use or operate this engine on any forest-covered, brush-covered or grass-covered land. Other states or federal areas may have similar laws.

Contents

	Page		Page
Safety	2	Operating Mower Blade Control (PTO) ..	21
Safe Operating Practices	2	The Safety Interlock System	21
Toro Mower Safety	4	Driving Forward or Backward	22
Slope Chart	7	Lower Control Bar Operation	23
Safety and Instruction Decals	9	Stopping the Machine	23
Gasoline and Oil	10	Maintenance	24
Recommended Gasoline	10	Service Interval Chart	24
Stabilizer/Conditioner	11	Air Cleaner	25
Filling the Fuel Tank	11	Engine Oil	26
Check Engine Oil Level	11	Spark Plug	28
Assembly	12	Greasing and Lubrication	29
Loose Parts	12	Cleaning the Cooling System	30
Mount Control Panel and Fuel Tank	13	Tire Pressure	30
Install Shift Lever	13	Brake	31
Install Upper Handle	14	Fuel Tank	32
Connect Throttle Cable	14	Fuel Filter	33
Choke Adjustment	15	Drive Belt	33
Connect Wire Harness	15	Replacing the Traction Belt	34
Install Control Rods	16	Adjust Electric Clutch	35
Operation	18	Wiring Diagram	36
Think Safety First	18	Cleaning and Storage	37
Controls	18	Troubleshooting	38
Parking Brake	19	Warranty	Back Cover
Starting and Stopping the Engine	20		

THE ENCLOSED ENGINE OWNER'S MANUAL IS SUPPLIED FOR CALIFORNIA EMISSION CONTROL REGULATION INFORMATION ON EMISSION SYSTEMS, MAINTENANCE AND WARRANTY.

KEEP THIS ENGINE OWNER'S MANUAL WITH YOUR UNIT. SHOULD THIS ENGINE OWNER'S MANUAL BECOME DAMAGED OR ILLEGIBLE, REPLACE IMMEDIATELY. REPLACEMENTS MAY BE ORDERED THROUGH THE ENGINE MANUFACTURER.

Safety

This machine meets or exceeds CPSC blade safety requirements for rotary mowers and the B71.4 1999 specifications of the American National Standards Institute, in effect at time of production.

Note: The addition of certain attachments that do not meet American National Standards Institute certification will cause noncertification of this machine.

Improper use or maintenance by the operator or owner can result in injury. To reduce the potential for injury, comply with these safety instructions and always pay attention to the safety alert  symbol, which means CAUTION, WARNING, or DANGER—“personal safety instruction.” Failure to comply with the instruction may result in personal injury or death.

Safe Operating Practices

The following instructions are from ANSI standard B71.4—1999.

Training

- Read the Operator’s Manual and other training material. If the operator(s) or mechanic(s) can not read English it is the owner’s responsibility to explain this material to them.
- Become familiar with the safe operation of the equipment, operator controls, and safety signs.
- All operators and mechanics should be trained. The owner is responsible for training the users.
- Never let children or untrained people operate or service the equipment. Local regulations may restrict the age of the operator.
- The owner/user can prevent and is responsible for accidents or injuries occurring to himself or herself, other people or property.

Preparation

- Evaluate the terrain to determine what accessories and attachments are needed to properly and safely perform the job. Only use accessories and attachments approved by the manufacturer.
- Wear appropriate clothing including hard hat, safety glasses and ear protection. Long hair, loose clothing or jewelry may get tangled in moving parts.
- Inspect the area where the equipment is to be used and remove all objects such as rocks, toys and wire which can be thrown by the machine.
- Use extra care when handling gasoline and other fuels. They are flammable and vapors are explosive.
 - Use only an approved container
 - Never remove gas cap or add fuel with engine running. Allow engine to cool before refueling. Do not smoke.
 - Never refuel or drain the machine indoors.
- Check that operator’s presence controls, safety switches and shields are attached and functioning properly. Do not operate unless they are functioning properly.

Operation

- Never run an engine in an enclosed area.
- Only operate in good light, keeping away from holes and hidden hazards.
- Be sure all drives are in neutral and parking brake is engaged before starting engine. Only start engine from the operator's position. Use seat belts if provided.
- Be sure of your footing while using pedestrian controlled equipment, especially when backing up. Walk, don't run. Never operate on wet grass. Reduced footing could cause slipping.
- Slow down and use extra care on hillsides. Be sure to travel in the recommended direction on hillsides. Turf conditions can affect the machine's stability. Use caution while operating near drop-offs.
- Slow down and use caution when making turns and when changing directions on slopes.
- Never raise deck with the blades running.
- Never operate with the PTO shield, or other guards not securely in place. Be sure all interlocks are attached, adjusted properly, and functioning property.
- Never operate with the discharge deflector raised, removed or altered, unless using a grass catcher.
- Do not change the engine governor setting or overspeed the engine.
- Stop on level ground, lower implements, disengage drives, engage parking brake (if provided), shut off engine before leaving the operator's position for any reason including emptying the catchers or unclogging the chute.
- Stop equipment and inspect blades after striking objects or if an abnormal vibration occurs. Make necessary repairs before resuming operations.
- Keep hands and feet away from the cutting units.
- Look behind and down before backing up to be sure of a clear path.
- Never carry passengers and keep pets and bystanders away.
- Slow down and use caution when making turns and crossing roads and sidewalks. Stop blades if not mowing.
- Be aware of the mower discharge direction and do not point it at anyone.
- Do not operate the mower under the influence of alcohol or drugs
- Use care when loading or unloading the machine into a trailer or truck
- Use care when approaching blind corners, shrubs, trees, or other objects that may obscure vision.

Maintenance and Storage

- Disengage drives, lower implement, set parking brake, stop engine and remove key or disconnect spark plug wire. Wait for all movement to stop before adjusting, cleaning or repairing.
- Clean grass and debris from cutting units, drives, mufflers, and engine to help prevent fires. Clean up oil or fuel spillage.
- Let engine cool before storing and do not store near flame.
- Shut off fuel while storing or transporting. Do not store fuel near flames or drain indoors.
- Park machine on level ground. Never allow untrained personnel to service machine.
- Use jack stands to support components when required.
- Carefully release pressure from components with stored energy.

- Disconnect battery or remove spark plug wire before making any repairs. Disconnect the negative terminal first and the positive last. Reconnect positive first and negative last.
- Use care when checking blades. Wrap the blade(s) or wear gloves, and use caution when servicing them. Only replace blades. Never straighten or weld them.
- Keep hands and feet away from moving parts. If possible, do not make adjustments with the engine running.
- Charge batteries in an open well ventilated area, away from spark and flames. Unplug charger before connecting or disconnecting from battery. Wear protective clothing and use insulated tools.
- Keep all parts in good working condition and all hardware tightened. Replace all worn or damaged decals.

Toro Mower Safety

The following list contains safety information specific to Toro products or other safety information that you must know that is not included in the ANSI standards.

This product is capable of amputating hands and feet and throwing objects. Always follow all safety instructions to avoid serious injury or death.

WARNING

POTENTIAL HAZARD

- **Engine exhaust contains carbon monoxide, which is an odorless, deadly poison.**

WHAT CAN HAPPEN

- **Carbon monoxide can kill you and is also known to the State of California to cause birth defects.**

HOW TO AVOID THE HAZARD

- **Do not run engine indoors or in an enclosed area.**

This product is designed for cutting and recycling grass or, when equipped with a grass bagger, for catching cut grass. Any use for purposes other than these could prove dangerous to user and bystanders.

Note: This engine is not equipped with a spark arrester muffler. It is a violation of California Public Resource Code Section 4442 to use or operate this engine on any forest-covered, brush-covered or grass-covered land. Other states or federal areas may have similar laws.

General Operation

- Allow only responsible adults who are familiar with the instructions to operate the machine.
- Be sure the area is clear of other people before mowing. Stop the machine if anyone enters the area.
- Do not mow in reverse unless absolutely necessary. Always look down and behind before and while backing.
- Be aware of the mower discharge direction and do not point it at anyone. Do not operate the mower without either the entire grass catcher or the guard in place.
- Slow down before turning. Sharp turns on any terrain may cause loss of control.
- Turn off blades when not mowing.
- Keep hands, feet, hair and loose clothing away from attachment discharge area, underside of mower and any moving parts while engine is running.
- Stop the engine before removing the grass catcher or unclogging the chute.
- Mow only in daylight or good artificial light.
- Watch for traffic when operating near or crossing roadways.

- Do not touch equipment or attachment parts which may be hot from operation. Allow to cool before attempting to maintain, adjust or service.
- Before operating a machine with ROPS (roll over protection) be certain the seat belts are attached to prevent the seat from pivoting forward.

Slope Operation

Slopes and ramps are a major factor related to loss-of-control and tip-over accidents, which can result in severe injury or death. All slopes and ramps require extra caution. If you cannot back up the slope or if you feel uneasy on it, do not mow it.

DO

- Mow up and down slopes greater than 5°, not across.
- Mow downhill only on slopes above 10°, never mow uphill. If a steep slope must be ascended, back up the hill, and drive forward down the hill, keeping the machine in gear.
- Remove obstacles such as rocks, tree limbs, etc. from the mowing area. Watch for holes, ruts or bumps, as uneven terrain could overturn the machine. Tall grass can hide obstacles.
- Use slow speed so that you will not have to stop while on the slope.
- Follow the manufacturer's recommendations for wheel weights or counterweights to improve stability.
- Use extra care with grass catchers or other attachments. These can change the stability of the machine.
- Keep all movement on slopes slow and gradual. Do not make sudden changes in speed or direction.
- Avoid starting or stopping on a slope. If tires lose traction, disengage the blades and proceed slowly straight down the slope.

- When operating machine on slopes, banks or near drop offs, always have ROPS (roll over protection) installed.
- When operating a machine with ROPS (roll over protection) always use seat belt.
- Be certain that the seat belt can be released quickly if the machine is driven or rolls into ponds or water.
- Check carefully for overhead clearances (i.e. branches, doorways, electrical wires) before driving under any objects and do not contact them.

DO NOT

- Do not operate machine on hillsides or slopes exceeding 15°.
- Avoid turning on slopes. If you must turn, turn slowly and gradually downhill, if possible.
- Do not mow near drop-offs, ditches, or embankments. The machine could suddenly turn over if a wheel goes over the edge of a cliff or ditch, or if an edge caves in.
- Do not mow on wet grass. Reduced traction could cause sliding.
- Do not try to stabilize the machine by putting your foot on the ground.
- Do not use a grass catcher on steep slopes. Heavy grass bags could cause loss of control or overturn the machine.

Service

- Never store the machine or fuel container inside where there is an open flame, such as near a water heater or furnace.
- Keep nuts and bolts tight, especially the blade attachment bolts. Keep equipment in good condition.
- Never tamper with safety devices. Check safety systems for proper operation before each use.

- Use only genuine replacement parts to ensure that original standards are maintained.
- Check brake operation frequently. Adjust and service as required.
- Battery acid is poisonous and can cause burns. Avoid contact with skin, eyes and clothing. Protect your face, eyes and clothing when working with a battery.
- Battery gases can explode. Keep cigarettes, sparks and flames away from battery.
- Hydraulic fluid escaping under pressure can penetrate the skin and cause injury. Use cardboard or paper to find hydraulic leaks.
- Never modify ROPS (roll over protection) frames or structures because they are specifically designed, sized, located and tested for injury reduction. If a rollover occurs, a modified ROPS will not provide adequate protection.

Slope Chart

Read all safety instructions on pages 2-9.

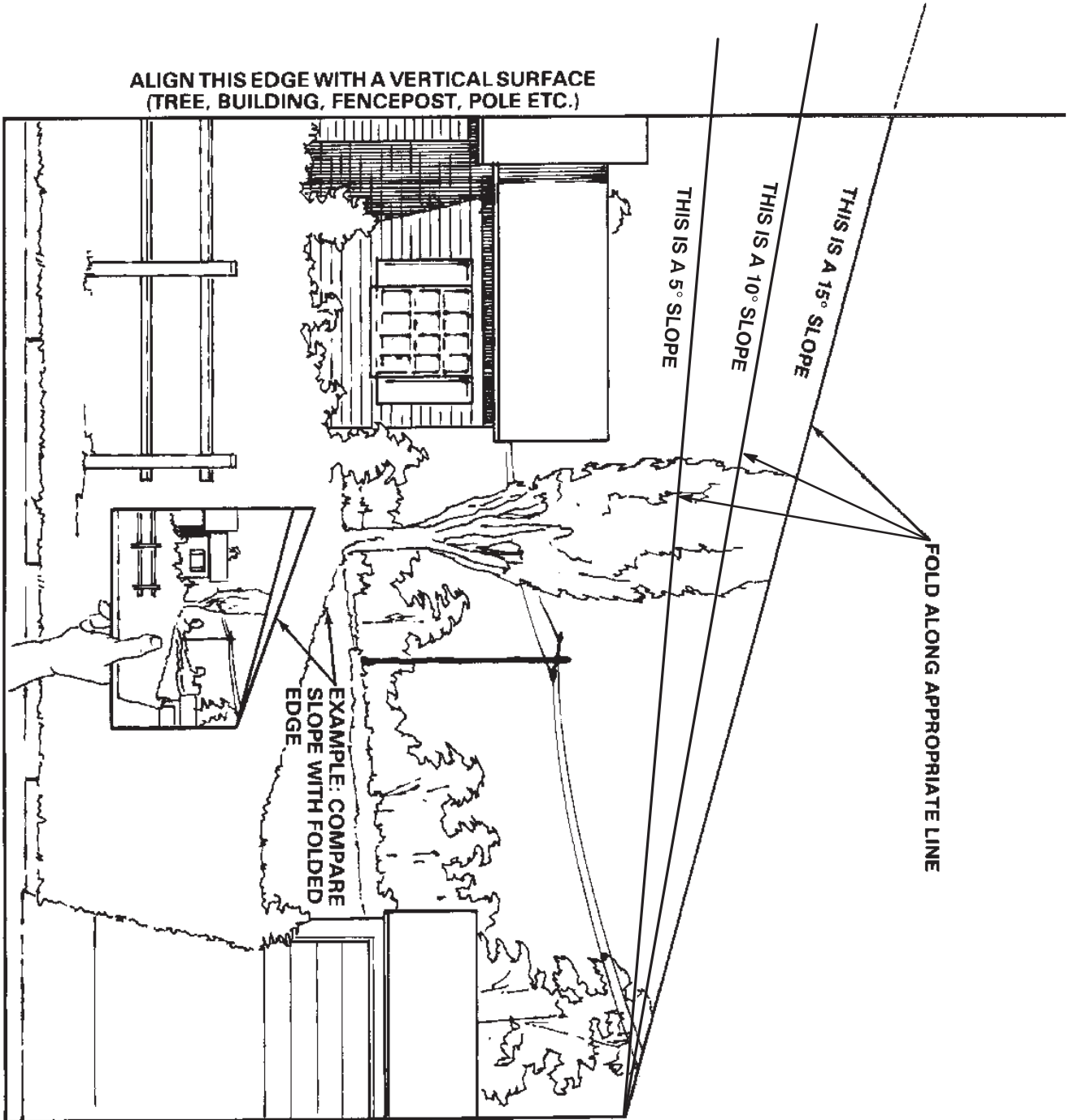

Safety and Instruction Decals



Safety decals and instructions are easily visible to the operator and are located near any area of potential danger. Replace any decal that is damaged or lost.



ON UPPER CONTROL BAR
(Part No. 82-2290)



ON LOWER CONTROL BAR
(Part No. 82-2280)

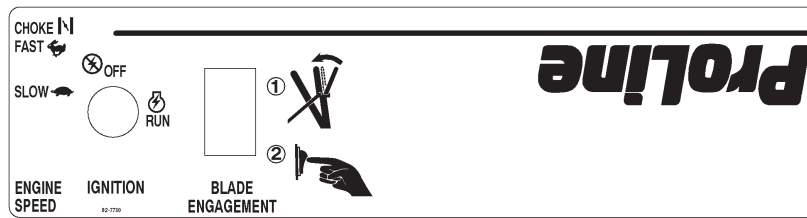

ON CONTROL PANEL
(Part No. 82-7730)



ON CONTROL PANEL
(Part No. 71-1280)



ON PARKING BRAKE LEVER
(Part No. 52-2010)

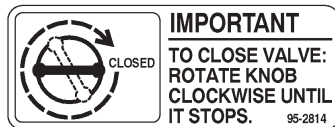

ON REAR FRAME
(Part No. 95-2814)

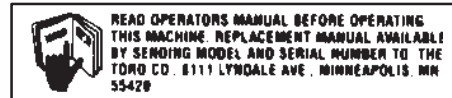

ON CONTROL PANEL
(Part No. 65-3090)



ON CONTROL PLATE
(Part No. 82-7750)



ON ENGINE NEAR MUFFLER
(Part No. 63-8440)

Gasoline and Oil

Recommended Gasoline

Use UNLEADED Regular Gasoline suitable for automotive use (85 pump octane minimum). Leaded regular gasoline may be used if unleaded regular is not available.

IMPORTANT: Never use methanol, gasoline containing methanol, or gasohol containing more than 10% ethanol because the fuel system could be damaged. Do not mix oil with gasoline.

DANGER

POTENTIAL HAZARD

- In certain conditions gasoline is extremely flammable and highly explosive.

WHAT CAN HAPPEN

- A fire or explosion from gasoline can burn you, others, and cause property damage.

HOW TO AVOID THE HAZARD

- Use a funnel and fill the fuel tank outdoors, in an open area, when the engine is cold. Wipe up any gasoline that spills.
- Do not fill the fuel tank completely full. Add gasoline to the fuel tank until the level is 1/4" to 1/2" (6 mm to 13 mm) below the bottom of the filler neck. This empty space in the tank allows gasoline to expand.
- Never smoke when handling gasoline, and stay away from an open flame or where gasoline fumes may be ignited by a spark.
- Store gasoline in an approved container and keep it out of the reach of children. Never buy more than a 30-day supply of gasoline.

DANGER

POTENTIAL HAZARD

- When fueling, under certain circumstances, a static charge can develop, igniting the gasoline.

WHAT CAN HAPPEN

- A fire or explosion from gasoline can burn you and others and cause property damage.

HOW TO AVOID THE HAZARD

- Always place gasoline containers on the ground away from your vehicle before filling.
- Do not fill gasoline containers inside a vehicle or on a truck or trailer bed because interior carpets or plastic truck bed liners may insulate the container and slow the loss of any static charge.
- When practical, remove gas-powered equipment from the truck or trailer and refuel the equipment with its wheels on the ground.
- If this is not possible, then refuel such equipment on a truck or trailer from a portable container, rather than from a gasoline dispenser nozzle.
- If a gasoline dispenser nozzle must be used, keep the nozzle in contact with the rim of the fuel tank or container opening at all times until fueling is complete.

Stabilizer/Conditioner

Use a fuel stabilizer/conditioner in the machine to provide the following benefits:

- Keeps gasoline fresh during storage of 90 days or less. For longer storage, drain the fuel tank.
- Cleans the engine while it runs
- Eliminates gum-like varnish buildup in the fuel system, which causes hard starting

IMPORTANT: Do not use fuel additives containing methanol or ethanol.

Add the correct amount of gas stabilizer/conditioner to the gas.

Note: A fuel stabilizer/conditioner is most effective when mixed with fresh gasoline. To minimize the chance of varnish deposits in the fuel system, use fuel stabilizer at all times.

Filling the Fuel Tank

1. Shut the engine off.
2. Clean around the fuel tank cap and remove the cap. Use a funnel and add unleaded regular gasoline to the fuel tank, until the level is 1/4 to 1/2 inch (6 mm to 13 mm) below the bottom of the filler neck. This space in the tank allows gasoline to expand. Do not fill the fuel tank completely full.
3. Install the fuel tank cap securely. Wipe up any gasoline that may have spilled.

Check Engine Oil Level

Before you start the engine and use the machine, check the oil level in the engine crankcase; refer to [Checking Oil Level](#), page 27.

Assembly

Loose Parts

Note: Use the chart below to verify all parts have been shipped.

DESCRIPTION	QTY.	USE
Fuel tank	1	Install fuel tank and control panel
Control panel	1	
Bolt 5/16–1/ x 7/8" (22.5 mm)	4	
Lock washer 5/16"	4	
Washer 5/16"	4	
Hose clamp	2	
Shift lever	1	Install shift lever to transmission
Shift lever mounting bracket	1	
Washer 1/4"	1	
Bolt 1/4–28 x 2" (51 mm)	1	
Upper handle	1	Install upper handle to frame
Flanged bolt 3/8–16 x 1" (26 mm)	4	
Flange nut 3/8–16	4	
Rod fitting	2	Install control rods
Clevis pin	2	
Washer 1/4"	2	
Hairpin cotter	2	
Clamp	1	Attach wire harness
Lock nut 5/16-18	2	
Wire Tie	1	
Operator's Manual	1	Read before operating machine
Engine Operator's Manual	1	
Parts Catalog	1	
Registration card	1	Fill out and return to Toro

Mount Control Panel and Fuel Tank

1. Slide control panel over shift lever and under bottom of rear frame (Fig. 1). Align fuel tank to top of rear frame (Fig. 1).

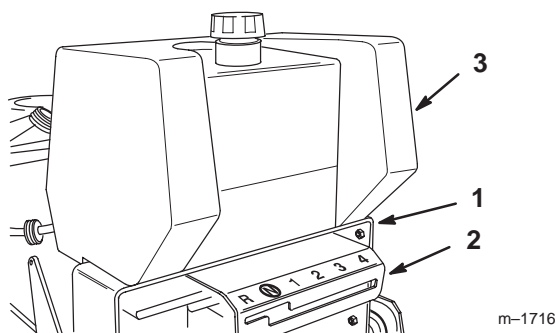

Figure 1

- | | |
|------------------|--------------|
| 1. Rear frame | 3. Fuel tank |
| 2. Control panel | |

2. Secure control panel and fuel tank to rear frame with (4) 7/8 in. (22.5 mm) bolts, lock washers and washers (Fig. 2).

Note: Place transmission in neutral. Align control panel so there is .060 in. (2 mm) space between panel and lever.

3. Slide hose clamp onto fuel line (Fig. 2). Push fuel line onto fuel tank fitting and secure with hose clamp (Fig. 2).

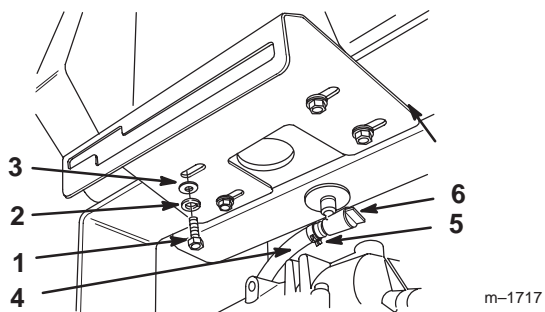

Figure 2

- | | |
|---------------------------------|-----------------|
| 1. Bolt 5/8–18 x 7/8" (22.5 mm) | 4. Fuel line |
| 2. Lock washer | 5. Hose clamp |
| 3. Washer | 6. Fuel fitting |

Install Shift Lever

1. Align mounting block with flats of shaft on top of transmission and slide onto shaft (Fig. 3).

Note: DO NOT remove rubber washer on transmission shaft.

2. Slide shift lever through control panel and align mounting hole in lever with mounting block on transmission. Secure lever to transmission with 2 in. (51 mm) bolt and washer. Torque bolt to 115 in. lb. (13 N•m).

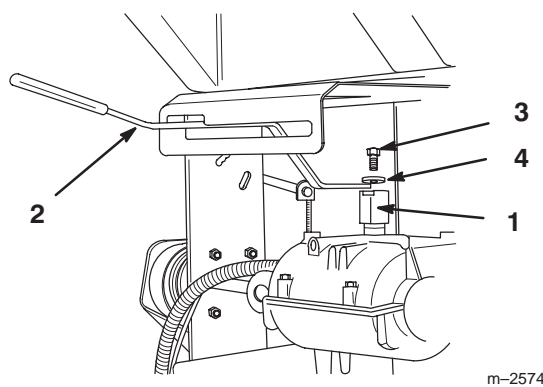

Figure 3

- | | |
|-------------------|-----------------------------|
| 1. Mounting block | 3. Bolt 1/4–28 x 2" (51 mm) |
| 2. Shift lever | 4. Washer |

Install Upper Handle

1. Align upper handle mounting holes with desired mounting holes in rear frame (upper or lower set of holes)
2. Secure each side with (2) 3/8 -16 x 1" (26mm) flange bolts and flange nuts (Fig. 4). Torque bolts to 25 ft. lbs. (34 N•m).
3. Route cables and wire harness inside of frame (Fig. 4). Secure wires and cable to handle with wire tie.

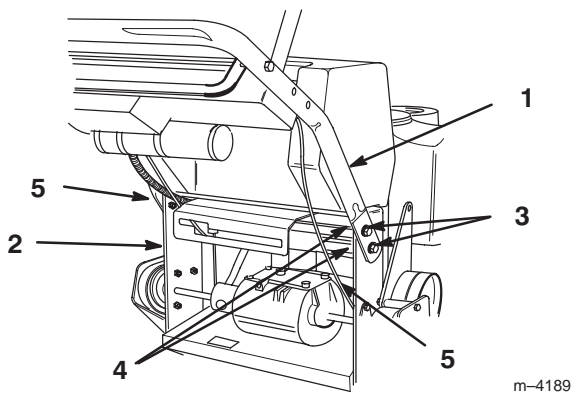

Figure 4

- | | |
|-----------------------------------|---------------------|
| 1. Upper handle | 4. Flange nut 3/8 |
| 2. Rear frame | 5. Wires and cables |
| 3. Flange bolt 3/8 x 16-1" (26mm) | |

Connect Throttle Cable

1. Route engine speed control cable around left side of engine.
2. Place throttle control in FAST position.
3. Hook wire Z-bend into speed control lever on engine (Fig. 5).
4. Loosen cable clamp bolt and insert cable, but do not tighten (Fig. 5).
5. Align the hole in the speed control lever with the hole in the base plate (Fig. 5) by moving the lever. Insert a 6 mm diameter pin or 6 mm bolt through two holes.
6. Pull up the outer housing of the throttle cable until the inner wire has almost no slack, and tighten the cable clamp bolt (Fig. 5). Remove the 6 mm diameter pin or bolt.

Note: Make sure that the carburetor choke valve (Fig. 6) is closed completely when the throttle lever is moved to CHOKE position. If not, perform Choke Adjustment, page 15.

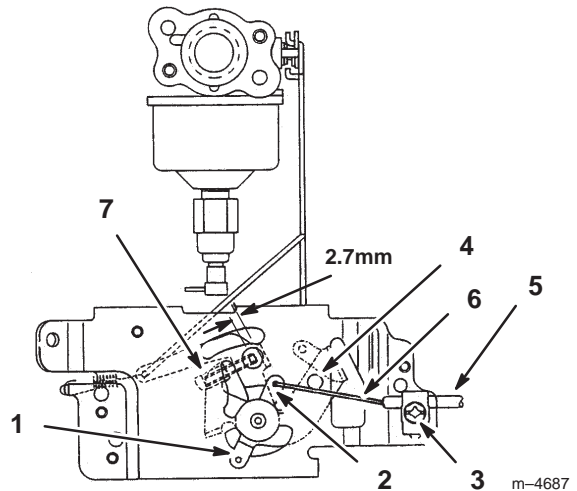
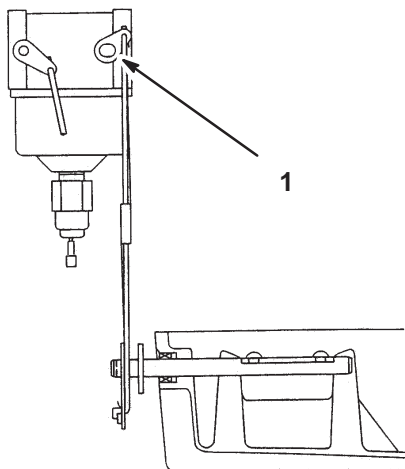

Figure 5

- | | |
|------------------------|---------------------------------|
| 1. Speed control lever | 5. Throttle cable outer housing |
| 2. Z-bend in wire | 6. Throttle cable inner wire |
| 3. Cable clamp bolt | 7. Choke setting screw |
| 4. Align holes | |



m-4712

Figure 6

1. Carburetor choke valve

Choke Adjustment

1. Place throttle control in CHOKE position.
2. Align the hole in the speed control lever with the hole in the base plate (Fig. 5) by moving the lever. Insert a 6 mm diameter pin or 6 mm bolt through two holes.
3. Turn the choke setting screw so that the clearance between the screw end and the tongue of the lever is 2.7 mm (Fig. 5). Remove the 6 mm diameter pin or bolt.

Note: Make sure that the choke valve turns from fully closed position to fully opened position when moving throttle control to FAST position.

Connect Wire Harness

1. Route wire harness along inside of left handle bracket.
2. Plug clutch wire into connector (Fig. 7).
3. Secure the black ground wire to engine mount with 5/16" nut (Fig. 7).
4. Secure wire harness to upper handle with cable tie.

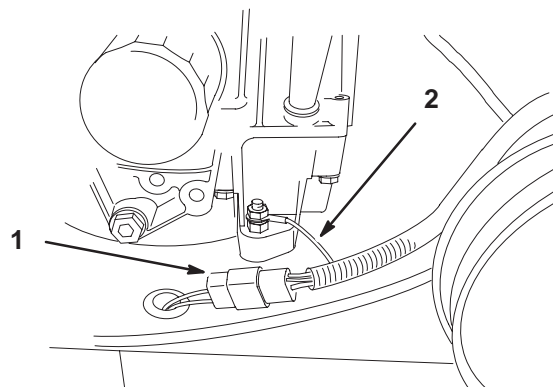

m-4713

Figure 7

1. Clutch wire connector
2. Ground wire

5. Route the other part of the wire harness around to the right side of the engine and secure with clamp and nut on engine base (Fig. 8).
6. Push the two wires together (Fig. 8).

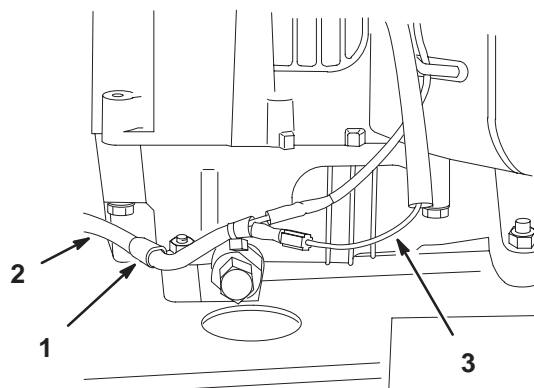

m-4688

Figure 8

1. Clamp and nut
2. Wire harness
3. Engine wire

Install Control Rods

1. Thread rod fittings equal distance onto each control rod. For a starting point thread on approximately 2 in. (51 mm) (Fig. 9).
2. Slide clevis pins through rod fittings and mounting holes in idler brackets (from outside) (Fig. 9). Secure with washers and hairpin cottes (Fig. 9).

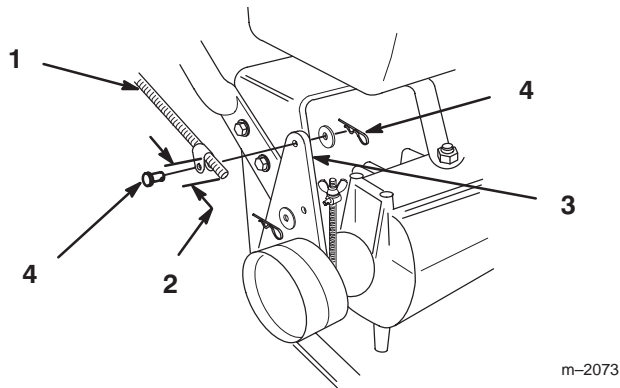

Figure 9

- | | |
|----------------------------|--|
| 1. Control rod and fitting | 4. Clevis pin, washer and hairpin cotter |
| 2. 2 in. (51 mm) | |
| 3. Idler bracket | |

3. Check the gap between upper control bar and fixed bar with wheel drive fully engaged. Gap should be approximately 1 to 1-1/4 in. (25–32 mm) (Fig. 10).

Note: The upper control bar and fixed bar must be parallel when in engaged, drive, relaxed and brake positions.

4. Check operation. If adjustment is required, remove hairpin cotter securing rod to upper control bar. Thread rod in or out of fitting for proper position and install into upper control bar with hairpin cotter.

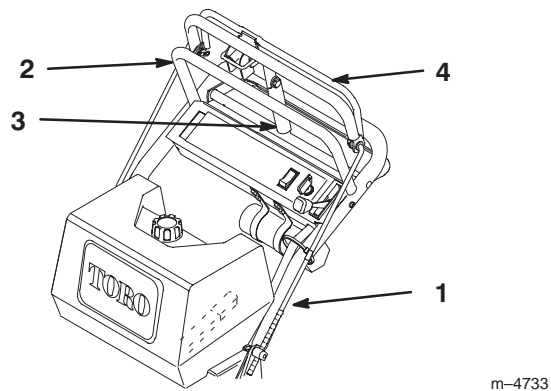

Figure 10

- | | |
|----------------------|------------------------|
| 1. Control rod | 3. Parking brake lever |
| 2. Fixed control bar | 4. Upper control bar |

5. Check parking brake adjustment. Brake rods should be adjusted so parking brake lever is snug when swung into position against the fixed bar while pulling back on upper control bar (Fig. 10).

6. If brake adjustment is required, remove hairpin cotter and washer securing brake rod fitting to idler bracket (Fig. 11).
7. Adjust wing nut up or down on brake rod and secure fitting to idler bracket (Fig. 11). Check adjustment and readjust if necessary.

Note: Make sure brake rod is installed in front (“F”) mounting hole in idler bracket.

8. Repeat procedure on opposite side if adjustment is required.

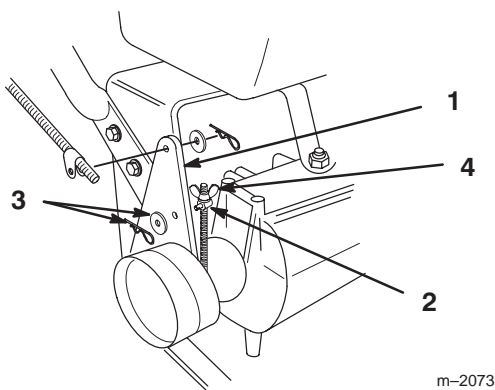

Figure 11

- | | |
|----------------------|------------------------------|
| 1. Idler bracket | 3. Hairpin cotter and washer |
| 2. Brake rod fitting | 4. Wing nut |

Operation

Think Safety First

Please carefully read all the safety instructions and symbols in the safety section. Knowing this information could help you, your family, pets or bystanders avoid injury.

Controls

Become familiar with all the controls (Fig. 12) before you start the engine and operate the machine.

Throttle Control – The throttle control has three positions: SLOW, FAST and CHOKE.

Deck Engagement Control Bail – Control bail used in conjunction with deck engagement switch (PTO) to release blade brake and engage clutch to drive mower blades. Release bail to disengage mower blades.

Blade Control Switch (PTO) – Rocker switch used in conjunction with control bail to release blade brake and engage clutch to drive mower blades.

Gear Shift Lever – Transmission has four forward speeds, neutral and reverse, and has an in-line shift pattern. Do not shift while unit is moving, as transmission damage may occur.

Upper Control Bar – Shift to desired gear and push forward on control bar to engage forward traction operation and pull back to brake. Pull right side of control bar to turn right and left side to turn left.

Lower Control Bar – Shift transmission to reverse and pull squeeze lower control bar to engage rearward traction operation.

Parking Brake Lever – Pull back on upper control bar and swing brake lever up against the upper handle to engage.

Ignition Switch – Key switch is used in conjunction with recoil starter. Switch has two positions: RUN and OFF.

Recoil Starter – Pull recoil Starter handle to start engine.

Fuel Shut-off Valve – (Under fuel tank) Close fuel shut-off valve when transporting or storing mower.

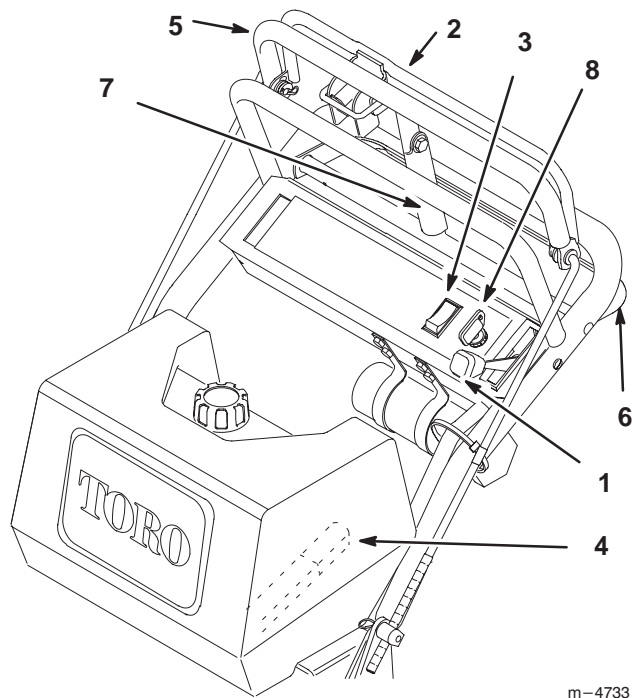

Figure 12

- | | |
|-------------------------------|------------------------|
| 1. Throttle control | 5. Upper control bar |
| 2. Blade control bail | 6. Lower control bar |
| 3. Blade control switch (PTO) | 7. Parking brake lever |
| 4. Gear shift lever | 8. Ignition switch |

Parking Brake

Always set the parking brake when you stop the machine or leave it unattended.

Setting the Parking Brake

1. Pull the upper control bar (Fig. 13) rearward and hold it in this position.
2. Lift the parking brake lock (Fig. 13) up and gradually release the upper control bar. The brake lock should stay in the set (locked) position.

Releasing the Parking Brake

1. Pull rearward on the upper control bar (Fig. 13). Lower the parking brake lock to the released position.
2. Gradually release the upper control bar.

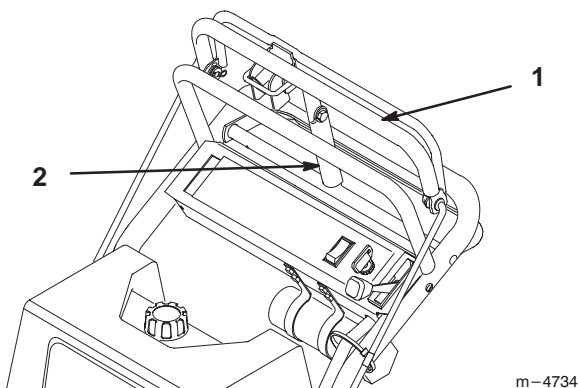

Figure 13

1. Upper control bar 2. Parking brake lock

Starting and Stopping the Engine

Starting

1. Make sure spark plug wire(s) are installed on spark plug(s) and fuel valve is open.
2. Move the shift lever to neutral, set the parking brake and turn ignition key to RUN (Fig. 14).
3. Move the throttle control to CHOKE position before starting a cold engine (Fig. 14).

Note: A warm or hot engine usually does not require any choking. To start a warm engine, move throttle control to FAST position.

4. Grasp recoil starter handle firmly and pull out until positive engagement results; then pull handle vigorously to start engine and allow rope to recoil slowly.

IMPORTANT: Do not pull recoil rope to its limit or let go of the starter handle when rope is pulled out because rope may break or recoil assembly may be damaged.

Stopping

1. Move the throttle lever to “SLOW” (Fig. 14).

Note: If the engine has been working hard or is hot, let it idle for a minute before turning the ignition key “OFF.” This helps cool the engine before it is stopped. In an emergency, the engine may be stopped by turning the ignition key to “OFF.”

2. Turn the ignition key to “OFF” (Fig. 14).

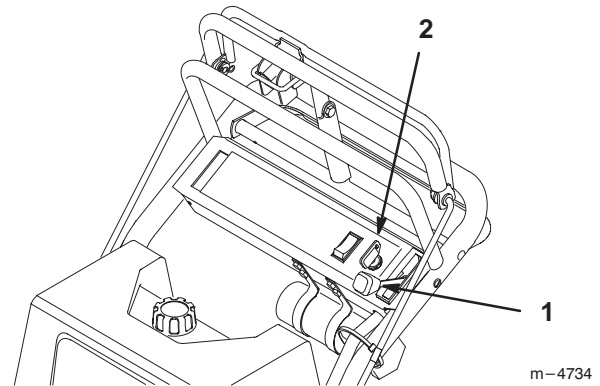

Figure 14

1. Throttle lever
2. Ignition key
3. Choke

3. Set the parking brake.
4. Pull wire off spark plug(s) to prevent possibility of accidental starting before storing machine.
5. Close fuel shut off valve before storing machine.

IMPORTANT: Make sure fuel shut off valve is closed before transporting or storing machine, as fuel leakage may occur.

Operating Mower Blade Control (PTO)

The blade control switch (PTO) in conjunction with the blade control bail engages and disengages power to the electric clutch and mower blades.

Engaging the Mower Blades (PTO)

1. Pull on the upper control bar to stop the machine (Fig. 15).
2. To engage blade, squeeze blade control bail against upper control bar
3. Press rocker switch forward “ON” and release. Hold blade control bail against control bar while operating.
4. Repeat procedure to engage mower blades if blade control bail is released.

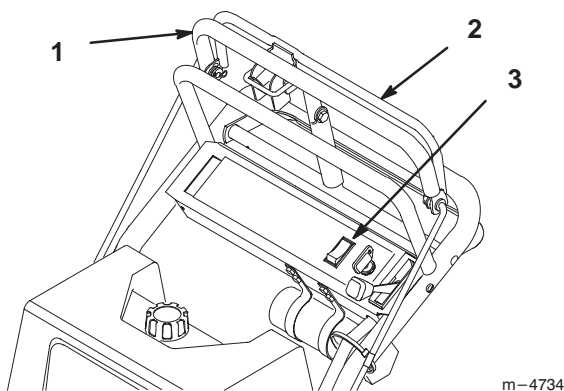

Figure 15

- | | |
|-----------------------|-------------------------------|
| 1. Upper control bar | 3. Blade control switch (PTO) |
| 2. Blade control bail | |

Disengaging the Mower Blades (PTO)

1. Releasing blade control bail to disengage blades (PTO) (Fig. 15).
2. Or push the blade control switch (PTO) to the “OFF” position (Fig. 15).

The Safety Interlock System

Understanding the Safety Interlock System

The safety interlock system is designed to prevent the mower blades from rotating unless:

- The control bail is depressed
- The blade control switch (PTO) is pressed “ON”

The safety interlock system is designed to stop the mower blades if you released the blade control bail.

Testing the Safety Interlock System

Test the safety interlock system before you use the machine each time. If the safety system does not operate as described below, have an Authorized Service Dealer repair the safety system immediately.

1. Set the parking brake and start the engine :refer to Starting and Stopping the Engine, page 20
2. Squeeze the blade control bail against upper control bar. The blades should not rotate.
3. Then continue holding the blade control bail and press the rocker switch forward “ON” and release. The clutch should engage and the mower blades begin rotating.
4. Release the blade control bail. The blades should stop rotating.
5. Without holding the blade control bail, push the blade control switch (PTO) to “ON” and release. The blades should not rotate.

Driving Forward or Backward

The throttle control regulates the engine speed as measured in rpm (revolutions per minute). Place the throttle control in the “FAST” position for best performance.

Forward

1. To go forward, move the shift lever to a forward gear.
2. Release the parking brake: refer to Releasing the Parking Brake, page 19.
3. Slowly press on the upper control bar to move forward (Fig. 16).

To go straight, apply equal pressure to both ends of the upper control bar (Fig. 16).

To turn, release pressure on the upper control bar side away from the direction you want to turn (Fig. 16).

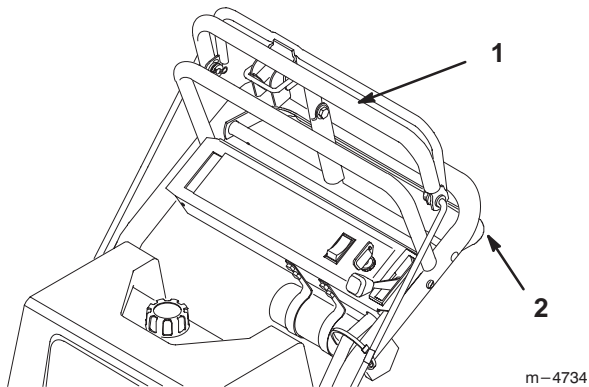

Figure 16

1. Upper control bar 2. Lower control bar

Backward

1. To go backward, move the shift lever to reverse gear.
2. Release the parking brake: refer to Releasing the Parking Brake, page 19.
3. Slowly squeeze on the lower control bar and handle together to move rearward (Fig. 16).

Lower Control Bar Operation

This procedure is for driving up a curb. This can be performed while driving forward or backward.

1. Disengage the mower blades.

WARNING

POTENTIAL HAZARD

- A blade can be bent or damaged when driving up a curb. Blades could break apart and pieces could be thrown at bystanders or at you as you use the mower.

WHAT CAN HAPPEN

- Pieces of blade that may be thrown could seriously injure or kill you or bystanders.

HOW TO AVOID THE HAZARD

- Do not run blades while driving up a curb forward or backward.

2. Select first gear or reverse to drive machine.
3. Drive machine until drive wheels contact curb (Fig. 18).

Note: Both drive wheels should contact the curb and castor wheels straight.

4. At the same time engage lower control bar and lift up on handle (Fig. 17 and 18).

Note: Lifting up on handle will assist driving the machine up a curb and not spin the drive wheels.

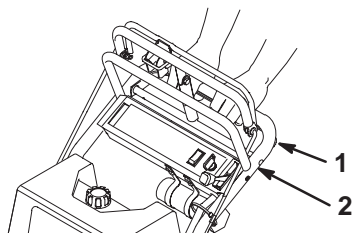
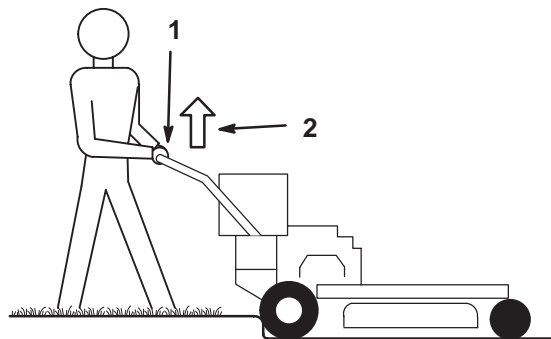

Figure 17

1. Lower Control Bar (Engaged)
2. Handle



m-4185

Figure 18

1. Lower Control Bar engaged and mower in reverse.
2. Pull up to assist machine

Stopping the Machine

To stop the machine, pull back on the upper control bar, release the blade control bail (PTO), and turn the ignition key to “OFF” to stop the engine. Also set the parking brake if you leave the machine unattended; refer to Setting the Parking Brake, page 19. Remember to remove the key from the ignition switch.

CAUTION

POTENTIAL HAZARD

- Someone could move or attempt to operate the machine while it is unattended.

WHAT CAN HAPPEN

- Children or bystanders may be injured if they use the machine.

HOW TO AVOID THE HAZARD

- Always remove the ignition key and set the parking brake when leaving the machine unattended, even if just for a few minutes.

Maintenance

Service Interval Chart

Service Operation	Each Use	8 Hours	25 Hours	50 Hours	100 Hours	200 Hours	Storage Service
Oil—check level	X						X
Oil—change*		Initial			X		X
Oil Filter—change (200 hours or every other oil change)						X	X
Safety System—check	X						X
Brake—check	X						X
Wheel Bearings—grease*		X					X
Transmission Couplings—grease*						X	X
Foam Air Cleaner—service*			X				X
Paper Air Cleaner—replace*						X	X
Spark Plug(s)—check					X		X
Belts—check for wear/cracks				X			X
Electric Clutch—Adjust					X		X
Gasoline—drain							X
Engine—clean cooling system	X				X		X
Fuel Filter—replace						X	X
Tires—check pressure				X			X
Chipped Surfaces—paint							X
* More often in dusty, dirty conditions							

CAUTION

POTENTIAL HAZARD

- If you leave the key in the ignition switch, someone could start the engine.

WHAT CAN HAPPEN

- Accidental starting of the engine could seriously injure you or other bystanders.

HOW TO AVOID THE HAZARD

- Remove the key from the ignition switch and pull the wire(s) off the spark plug(s) before you do any maintenance. Also push the wire(s) aside so it does not accidentally contact the spark plug(s).

Air Cleaner

Service Interval/Specification

Foam Element: Clean and re-oil after every 25 operating hours.

Paper Element: Replace after every 200 operating hours.

Note: Service the air cleaner more frequently (every few hours) if operating conditions are extremely dusty or sandy.

Removing the Foam and Paper Elements

1. Disengage the power take off (PTO), set the parking brake, and turn the ignition key to "OFF" to stop the engine. Remove the key.
2. Clean around the air cleaner to prevent dirt from getting into the engine and causing damage. Pull out on retaining latches and remove the air cleaner cover (Fig. 19).
3. Unscrew nut and remove the air cleaner assembly (Fig. 19).
4. Carefully pull the foam element off the paper element (Fig. 19).

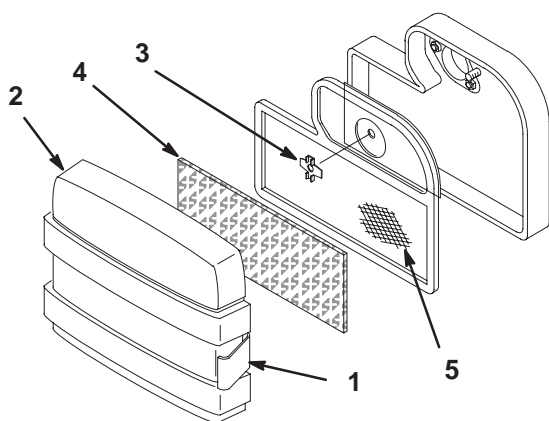

Figure 19

- | | |
|--------------------|------------------|
| 1. Retaining latch | 4. Foam element |
| 2. Cover | 5. Paper element |
| 3. Nut | |

Cleaning the Foam and Paper Elements

1. Foam Element
 - A. Wash the foam element in liquid soap and warm water. When the element is clean, rinse it thoroughly.
 - B. Dry the element by squeezing it in a clean cloth.
 - C. Put one or two ounces of oil on the element (Fig. 20). Squeeze the element to distribute the oil.

IMPORTANT: Replace the foam element if it is torn or worn.

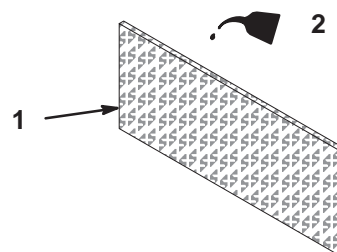

m-4694

Figure 20

- | | |
|-----------------|--------|
| 1. Foam element | 2. Oil |
|-----------------|--------|

Checking Oil Level

1. Park the machine on a level surface, disengage the power take off (PTO), set the parking brake, and turn the ignition key to “OFF” to stop the engine. Remove the key.
2. Clean around the oil dipstick (Fig. 22) so dirt cannot fall into the filler hole and damage the engine.
3. Unscrew the oil dipstick and wipe the metal end clean (Fig. 22).
4. Thread the oil dipstick fully onto the filler tube (Fig. 22). Pull the dipstick out and look at the metal end. If oil level is low, slowly pour only enough oil into the filler tube to raise the level to the “FULL” mark.

IMPORTANT: Do not overfill the crankcase with oil because the engine may be damaged.

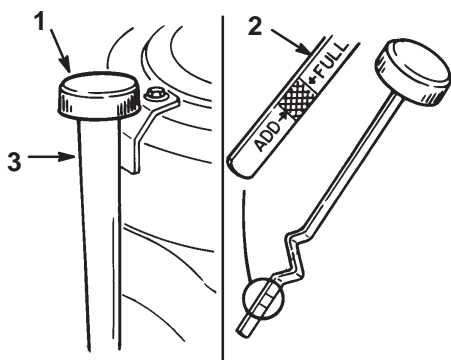

Figure 22

- | | |
|-----------------|----------------|
| 1. Oil dipstick | 3. Filler tube |
| 2. Metal end | |

Changing/Draining Oil

1. Start the engine and let it run five minutes. This warms the oil so it drains better.
2. Park the machine so that the drain side is slightly lower than the opposite side to assure the oil drains completely. Then disengage the power take off (PTO), set the parking brake, and turn the ignition key to “OFF” to stop the engine. Remove the key.
3. Place a pan below the oil drain. Remove the oil drain cap (Fig. 23).
4. When oil has drained completely, install the oil drain cap.

Note: Dispose of the used oil at a certified recycling center.

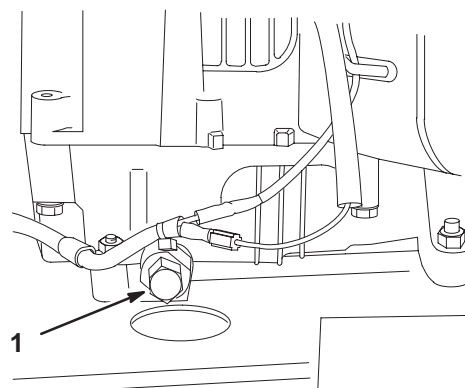

m-4688

Figure 23

1. Oil drain cap
5. Slowly pour approximately 80% of the specified amount of oil specified, page 26, into the filler tube (Fig. 22). Now check the oil level; refer to Checking Oil Level, page 27. Slowly add additional oil to bring to “FULL” mark on dipstick.

Change Oil Filter

Service Interval/Specification

Replace the oil filter every 200 hours or every other oil change.

Note: Change oil filter more frequently when operating conditions are extremely dusty or sandy.

1. Drain the oil from the engine; refer to Changing/Draining Oil, page 27.
2. Remove the old filter (Fig. 24).
3. Apply a thin coat of new oil to the rubber gasket on the replacement filter (Fig. 24).

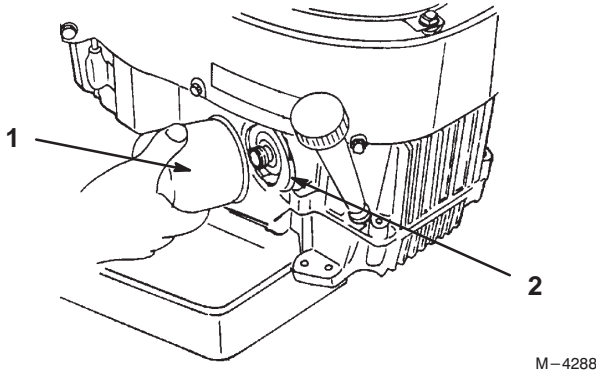

Figure 24

1. Oil filter
2. Adapter

4. Install the replacement oil filter to the filter adapter. Turn the oil filter clockwise until the rubber gasket contacts the filter adapter, then tighten the filter an additional 3/4 turn (Fig. 24).
5. Fill the crankcase with the proper type of new oil; refer to Changing/Draining Oil, page 27.

Spark Plug

Service Interval/Specification

Check the spark plug(s) after every 100 operating hours. Make sure the air gap between the center and side electrodes is correct before installing the spark plug. Use a spark plug wrench for removing and installing the spark plug(s) and a gapping tool/feeler gauge to check and adjust the air gap. Install a new spark plug(s) if necessary.

Type: Champion RCJ8Y (or equivalent)

Air Gap: 0.040 in. (1.02 mm)

Removing the Spark Plug(s)

1. Disengage the power take off (PTO), set the parking brake, and turn the ignition key to "OFF" to stop the engine. Remove the key.
2. Pull the wire(s) off the spark plug(s) (Fig. 25). Now clean around the spark plug(s) to prevent dirt from falling into the engine and potentially causing damage.
3. Remove the spark plug(s).

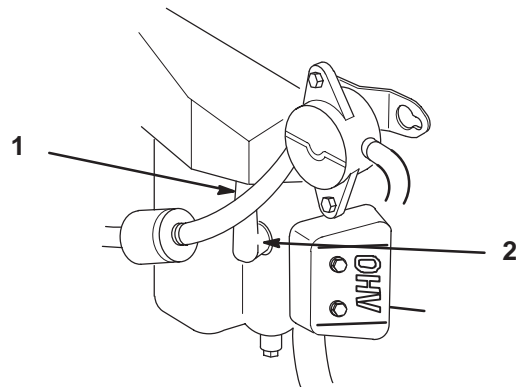

Figure 25

1. Spark plug wire installed
2. Spark plug

Checking the Spark Plug

1. Look at the center of the spark plug(s) (Fig. 26). If you see light brown or gray on the insulator, the engine is operating properly. A black coating on the insulator usually means the air cleaner is dirty.

IMPORTANT: Never clean the spark plug(s). Always replace the spark plug(s) when it has a black coating, worn electrodes, an oily film, or cracks.

2. Check the gap between the center and side electrodes (Fig. 26). Bend the side electrode (Fig. 26) if the gap is not correct.

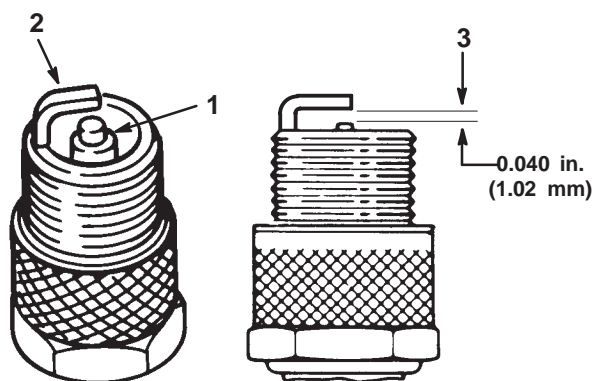

Figure 26

1. Center electrode insulator
2. Side electrode
3. Air gap (not to scale)

Installing the Spark Plug(s)

1. Install the spark plug(s). Make sure the air gap is set correctly.
2. Tighten the spark plug(s) to 11 ft-lb (15 N•m).
3. Push the wire(s) onto the spark plug(s) (Fig. 25).

Greasing and Lubrication

Service Interval/Specification

Grease the wheel bearings every 8 operating hours and the transmission couplers every 200 operating hours. Grease more frequently when operating conditions are extremely dusty or sandy.

Grease Type: General-purpose grease.

How to Grease

1. Disengage the power take off (PTO), set the parking brake, and turn the ignition key to “OFF” to stop the engine. Remove the key.
2. Clean the grease fittings with a rag. Make sure to scrape any paint off the front of the fitting(s).
3. Connect a grease gun to the fitting. Pump grease into the fittings until grease begins to ooze out of the bearings.
4. Wipe up any excess grease.

Where to Add Grease

1. Lubricate the wheel bearings and front spindles until grease begins to ooze out of the bearings (Fig. 27).

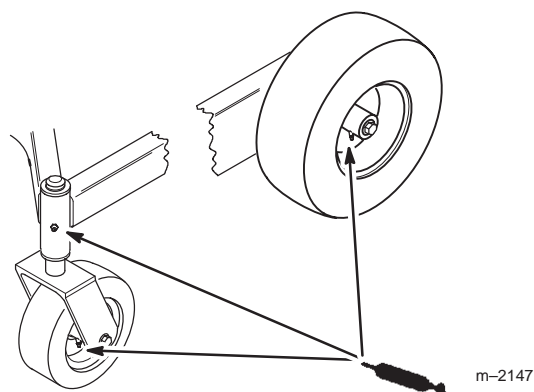
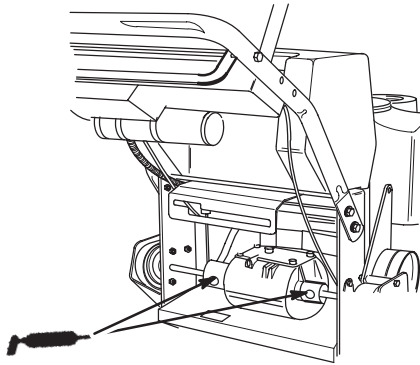

Figure 27

m-2147

2. Lubricate the transmission couplers (Fig. 28).



m-4189

Figure 28

Cleaning the Cooling System

Service Interval/Specification

Before each use, check and clean engine cooling system. Remove any build-up of grass, dirt or other debris from the cylinder and cylinder head cooling fins, air intake screen on flywheel end, and carburetor-governor levers and linkage. This will help insure adequate cooling and correct engine speed and will reduce the possibility of overheating and mechanical damage to the engine.

Tire Pressure

Service Interval/Specification

Maintain the air pressure in the front and rear tires as specified. Check the pressure at the valve stem after every 50 operating hours or monthly, whichever occurs first (Fig. 29). Check the tires when they are cold to get the most accurate pressure reading.

Pressure: 15 psi (103 kPa) rear tires
25–30 psi (172–207 kPa) castor tires

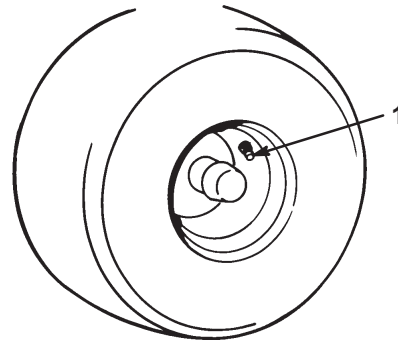

Figure 29

1. Valve stem

Brake

Service Interval/Specification

Before each use, check brakes for proper operation.

Always set the parking brake when you stop the machine or leave it unattended. If the parking brake does not hold securely, an adjustment is required.

Checking the Brake

1. Park the machine on a level surface, disengage the power take off (PTO), set the parking brake, and turn the ignition key to "OFF" to stop the engine. Remove the key.
2. Rear wheels must lock when you try to push the machine forward. Adjustment is required if the wheels turn and do not lock; refer to Adjusting the Brake, page 31.
3. Release the brake and press upper control bar very lightly, approximately 1/2 in. (13 mm), wheels should rotate freely.
4. If both conditions are met no adjustment is required.

Adjusting the Brake

The brake lever is on the upper control bar (Fig. 12). If the parking brake does not hold securely, an adjustment is required.

1. Check the brake before you adjust it; refer to Checking the Brake, page 31.
2. Release the parking brake; refer to Releasing the Parking Brake, page 19.
3. To adjust the brake remove the cotter pin and washer from the brake lever (Fig. 30).
4. Rotate the trunnion so it smoothly slides into brake lever (Fig. 30). Tighten wing nut.
5. Secure trunnion to brake lever with washer and cotter pin (Fig. 30).
6. Check the brake operation again; refer to Checking the Brake, page 31.

IMPORTANT: With the parking brake released, the rear wheels must rotate freely when you push the mower. If brake action and free wheel rotation cannot be achieved contact your service dealer immediately.

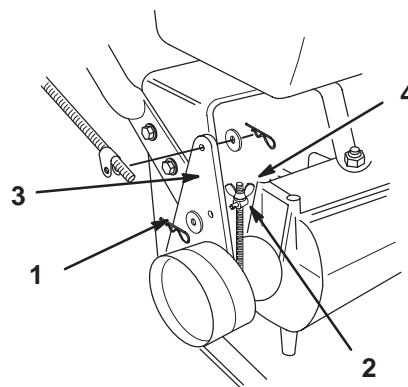

Figure 30

- | | |
|------------------------------|----------------|
| 1. Hairpin cotter and washer | 3. Brake lever |
| 2. Trunnion | 4. Wing nut |

m-2073

Fuel Tank

Draining The Fuel Tank

DANGER

POTENTIAL HAZARD

- In certain conditions gasoline is extremely flammable and highly explosive.

WHAT CAN HAPPEN

- A fire or explosion from gasoline can burn you, others, and cause property damage.

HOW TO AVOID THE HAZARD

- Drain gasoline from the fuel tank when the engine is cold. Do this outdoors in an open area. Wipe up any gasoline that spills.
- Never drain gasoline near an open flame or where gasoline fumes may be ignited by a spark.
- Never smoke a cigarette, cigar or pipe.

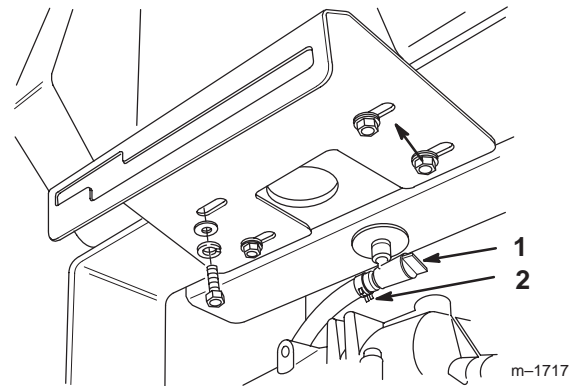

Figure 31

1. Fuel shut-off valve 2. Clamp

1. Park the machine on a level surface, to assure fuel tank drains completely. Then disengage the power take off (PTO), set the parking brake, and turn the ignition key to “OFF” to stop the engine. Remove the key.
2. Close fuel shut-off valve at fuel tank (Fig. 31).
3. Squeeze the ends of the hose clamp together and slide it up the fuel line away from valve (Fig. 31).
4. Pull the fuel line off the valve (Fig. 31). Open fuel shut-off valve and allow gasoline to drain into a gas can or drain pan.

Note: Now is the best time to install a new fuel filter because the fuel tank is empty. Refer to Replacing the Fuel Filter; page 33.

5. Install the fuel line onto the valve. Slide the hose clamp close to the valve to secure the fuel line.

Fuel Filter

Service Interval/Specification

Replace the fuel filter after every 200 operating hours or yearly, whichever occurs first.

Replacing the Fuel Filter

Never install a dirty filter if it is removed from the fuel line.

1. Disengage the power take off (PTO), set the parking brake, and turn the ignition key to "OFF" to stop the engine. Remove the key.
2. Close fuel shut-off valve at fuel tank (Fig. 31).
3. Squeeze the ends of the hose clamps together and slide them away from the filter (Fig. 32).
4. Remove the filter from the fuel lines.
5. Install a new filter and move the hose clamps close to the filter.
6. Open fuel shut-off valve at fuel tank (Fig. 31).

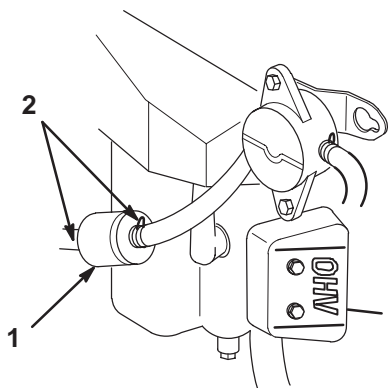

Figure 32

1. Filter
2. Hose clamp

M-4294

Drive Belt

Service Interval/Specification

Check all belts after every 50 operating hours or monthly, whichever occurs first. Look for dirt, wear, cracks, and signs of overheating.

Replacing the Drive Belt

1. Remove top capscrew securing idler support and idler bracket to rear frame (Fig. 33).
2. Loosen bottom two mounting screws enough to allow belt to pass between drive pulley and idler support (Fig. 33).
3. Raise wheel off ground enough to allow belt removal.

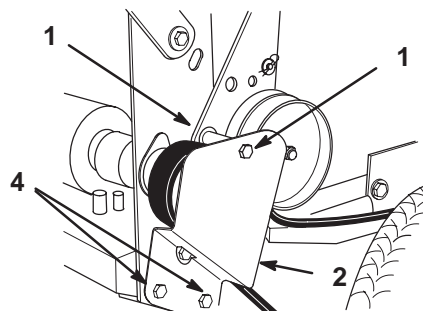

m-1722

Figure 33

1. Top capscrew
2. Idler bracket
3. Idler support
4. Bottom capscrew

Note: If the new belt slips, examine the pulley for wear. A good pulley will have gaps between the flat parts of the pulley and the belt (Fig. 34). If any of the gaps are missing, the pulley is worn out and the belt will not have good contact on the sides and will slip.

If the pulley is worn out, remove the two set screws and pulley, then replace the pulley with a new one.

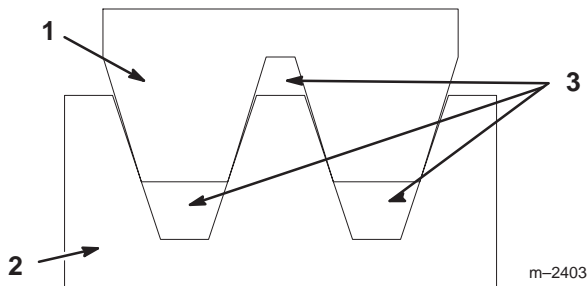

Figure 34

- | | |
|--------------------------------|--------|
| 1. Belt (cross section) | 3. Gap |
| 2. Good pulley (cross section) | |

8. Torque pivot bolt to 35–40 ft-lb. (47-54 N•m). Install tension spring between idler arm and frame bracket (Fig. 35).
9. Hook clutch retainer into clutch and secure to frame with engine mounting bolt. Torque engine mounting bolt to 170–220 in-lb. (19–24 N•m).
10. Connect clutch in-line wire connector to wire harness.

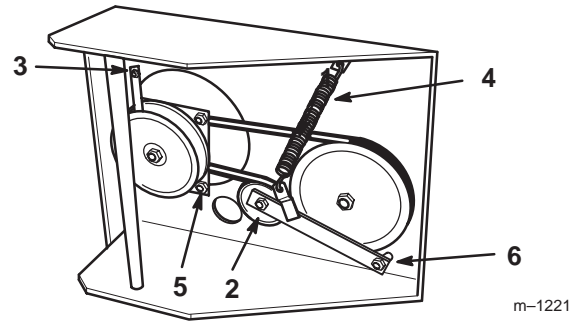

Figure 35

- | | |
|--------------------|-------------------|
| 1. Traction belt | 4. Tension spring |
| 2. Idler pulley | 5. Adjusting nut |
| 3. Clutch retainer | 6. Pivot bolt |

Replacing the Traction Belt

1. Raise the front of the machine and hold with jack stands.
2. Disconnect in-line wire connector from wire harness to electric clutch.
3. Remove mower drive belt; refer to mower Operator's Manual.
4. Remove left front engine mounting bolt securing clutch retainer to frame (Fig. 35). Unhook retainer from clutch and remove retainer.
5. Unhook tension spring from side of frame (Fig. 35).
6. Loosen pivot bolt enough to remove traction belt from the drive pulley and clutch.
7. Install new belt around clutch and drive pulley.

Adjust Electric Clutch

The clutch is adjustable to ensure proper engagement and proper braking. Check adjustment after every 100 hours of operation.

The electric clutch has three (3) adjustment nuts that all must be adjusted the same (Fig. 36).

1. Insert a 0.015 inch (.40 mm) feeler gauge into the slot (Fig. 36).
2. Turn the nut until light resistance is felt on the gauge.
3. Repeat for all three adjusting nuts.

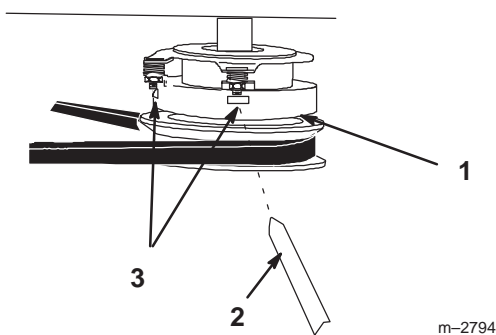
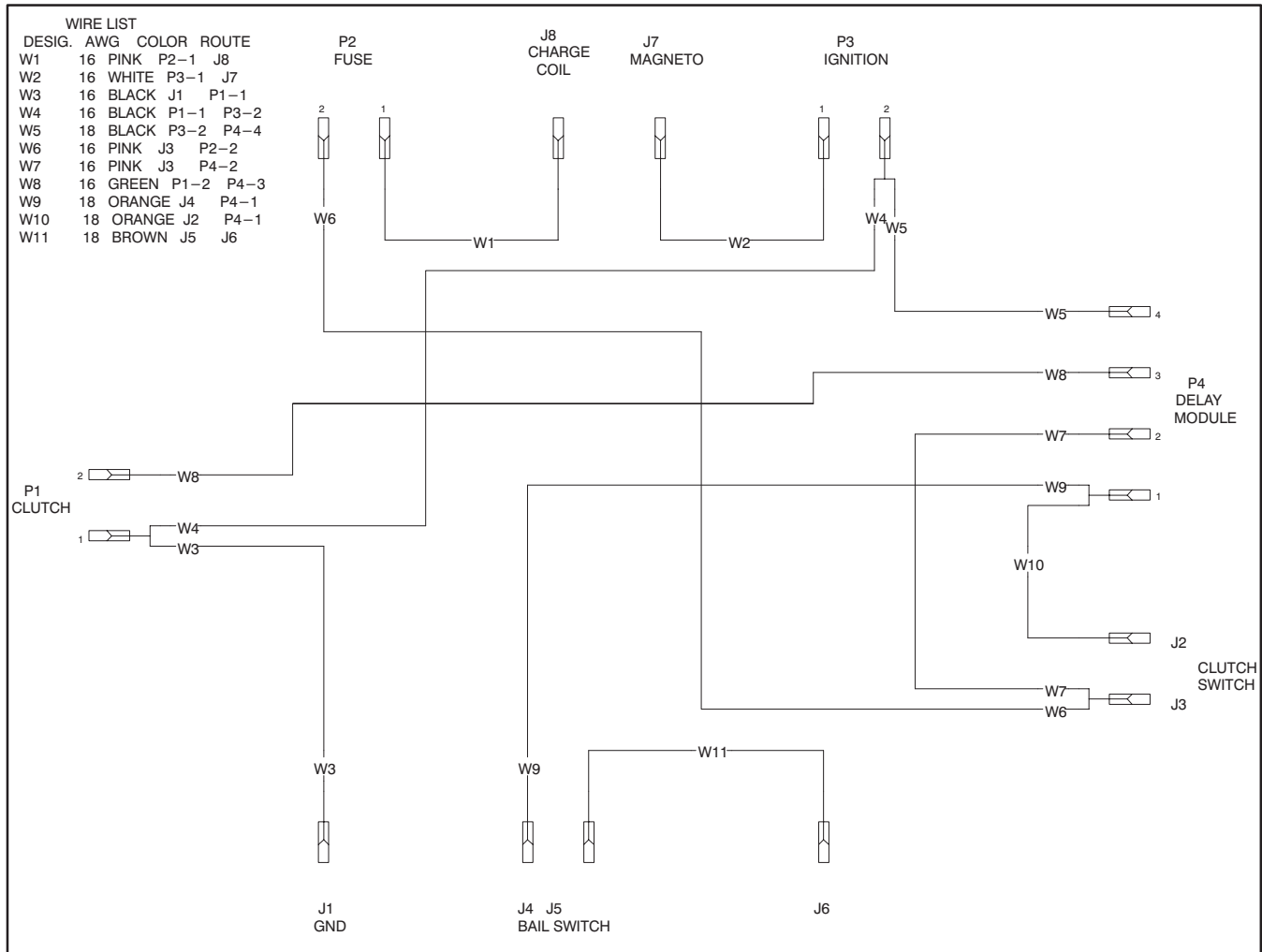

Figure 36

1. Slot
2. 0.015" (.40 mm) Feeler gauge
3. Adjusting nut

Wiring Diagram



Cleaning and Storage

1. Disengage the power take off (PTO), set the parking brake, and turn the ignition key to “OFF” to stop the engine. Remove the key.
2. Remove grass clippings, dirt, and grime from the external parts of the entire machine, especially the engine. Clean dirt and chaff from the outside of the engine’s cylinder head fins and blower housing.

IMPORTANT: You can wash the machine with mild detergent and water. Do not pressure wash the machine. Avoid excessive use of water, especially near the control panel, and engine.

3. Check the brake; refer to Brake, page 31.
4. Service the air cleaner; refer to Air Cleaner, page 25.
5. Grease the machine; refer to Greasing and Lubrication, page 29.
6. Change the crankcase oil; refer to Engine Oil, page 26.
7. Remove the spark plug(s) and check its condition; refer to Spark Plug, page 28. With the spark plug(s) removed from the engine, pour two tablespoons of engine oil into the spark plug hole. Now use the starter to crank the engine and distribute the oil inside the cylinder. Install the spark plug(s). Do not install the wire on the spark plug(s).
8. Check the tire pressure; refer to Tire Pressure, page 30.

9. For storage over 30 days, prepare the traction unit as follows.
 - A. Add a petroleum based stabilizer/conditioner to fuel in the tank. Follow mixing instructions from stabilizer manufacturer. (1 oz. per gallon). **Do not use an alcohol based stabilizer (ethanol or methanol).**

Note: A fuel stabilizer/conditioner is most effective when mixed with fresh gasoline and used at all times.

- B. Run the engine to distribute conditioned fuel through the fuel system (5 minutes).
- C. Stop the engine, allow it to cool and drain the fuel tank; refer to Draining Fuel Tank, page 32.
- D. Restart the engine and run it until it stops.
- E. Choke or prime the engine.
- F. Start and run the engine until it will not start again. Use the primer, if equipped on machine, several times to ensure no fuel remains in primer system.
- G. Dispose of fuel properly. Recycle as per local codes.

IMPORTANT: Do not store stabilizer/conditioned gasoline over 90 days.

10. Check and tighten all bolts, nuts, and screws. Repair or replace any part that is damaged or defective.
11. Paint all scratched or bare metal surfaces. Paint is available from your Authorized Service Dealer.
12. Store the machine in a clean, dry garage or storage area. Remove the key from the ignition switch and keep it in a memorable place. Cover the machine to protect it and keep it clean.

Troubleshooting

PROBLEM	POSSIBLE CAUSES	CORRECTIVE ACTION
Engine will not start, starts hard, or fails to keep running.	<ol style="list-style-type: none"> 1. Fuel tank is empty. 2. Choke is not ON. 3. Air cleaner is dirty. 4. Spark plug wire is loose or disconnected. 5. Spark plug is pitted, fouled, or gap is incorrect. 6. Dirt in fuel filter. 7. Dirt, water, or stale fuel is in fuel system. 	<ol style="list-style-type: none"> 1. Fill fuel tank with gasoline. 2. Move throttle lever to choke position. 3. Clean or replace air cleaner element. 4. Install wire on spark plug. 5. Install new, correctly gapped spark plug. 6. Replace fuel filter. 7. Contact Authorized Service Dealer.
Engine loses power.	<ol style="list-style-type: none"> 1. Engine load is excessive. 2. Air cleaner is dirty. 3. Oil level in crankcase is low. 4. Cooling fins and air passages under engine blower housing are plugged. 5. Spark plug is pitted, fouled, or gap is incorrect. 6. Vent hole in fuel cap is plugged. 7. Dirt in fuel filter. 8. Dirt, water, or stale fuel is in fuel system. 	<ol style="list-style-type: none"> 1. Reduce ground speed. 2. Clean air cleaner element. 3. Add oil to crankcase. 4. Remove obstruction from cooling fins and air passages. 5. Install new, correctly gapped spark plug. 6. Clean or replace the fuel cap. 7. Replace fuel filter. 8. Contact Authorized Service Dealer.
Engine overheats.	<ol style="list-style-type: none"> 1. Engine load is excessive. 2. Oil level in crankcase is low. 3. Cooling fins and air passages under engine blower housing are plugged. 	<ol style="list-style-type: none"> 1. Reduce ground speed. 2. Add oil to crankcase. 3. Remove obstruction from cooling fins and air passages.
Abnormal vibration.	<ol style="list-style-type: none"> 1. Engine mounting bolts are loose. 2. Loose engine pulley, idler pulley, or blade pulley. 3. Engine pulley is damaged. 	<ol style="list-style-type: none"> 1. Tighten engine mounting bolts. 2. Tighten the appropriate pulley. 3. Contact Authorized Service Dealer.

PROBLEM	POSSIBLE CAUSES	CORRECTIVE ACTION
Machine does not drive.	<ol style="list-style-type: none">1. Shift lever is in NEUTRAL.2. Traction belt is worn, loose or broken.3. Traction belt is off pulley.	<ol style="list-style-type: none">1. Move shift lever to a drive gear position.2. Change Belt.3. Change Belt.



LCE

THE TORO TOTAL COVERAGE GUARANTEE

A One-Year Limited Warranty (A Two-Year Full Warranty for Residential Use)

What Is Covered By This Express Warranty?

The Toro Company promises to repair any TORO Product used for commercial, institutional, or rental purposes if defective in materials or workmanship. The following time frames apply from the date of purchase:

<u>Product</u>	<u>Warranty Period</u>
All Products	1 year
All Spindles	2 years parts & labor, 3rd year parts only
Engines on the following:	2 years
Out Front and MidMount Zero Radius Tractors	
ProLine Mid-size Mowers	
Groundsmaster Riding Mowers	
ProLine Hand Held Gas Products (AE & LE engines only)	
Backpack Blowers	

The cost of parts and labor are included, but the customer pays the transportation cost. Transportation within a 15-mile radius of a TORO ProLine Service Dealer is covered under this warranty for Riding Products, Midsize Mowers and Turf Maintenance Equipment.

What Products Are Covered By This Warranty?

- Z-Master Zero Radius Tractors
- ProLine Mid-size Mowers
- Groundsmaster Riding Mowers
- ProLine Hand-held Gas Products
- Backpack Blowers
- Turf Maintenance Equipment
- Debris Management Equipment

How About Residential Use?

TORO Products used for residential use are covered by a full two-year warranty.

How Do You Get Warranty Service?

Should you feel your TORO Product contains a defect in materials or workmanship, contact the dealer who sold you the product or any TORO ProLine Service Dealer. The Yellow Pages of your telephone directory is a good reference source; look under TORO Commercial Service Dealers. The Service Dealer will either arrange service at his/her dealership or recommend another authorized Service Dealer who may be more convenient. You may need proof of purchase (copy of registration card, sales receipt, etc.) for warranty validation.

If for any reason you are dissatisfied with a Service Dealer's analysis of the defect in materials or workmanship or if you need a referral to a TORO ProLine Service Dealer, please feel free to contact us at the following address:

Toro Customer Service Department
8111 Lyndale Avenue South
Bloomington, MN 55420-1196
612-888-8801 or 800-348-2424

What Must You Do To Keep The Warranty In Effect?

You must maintain your TORO Product by following the maintenance procedures described in the operator's manual. Such routine maintenance, whether performed by a dealer or by you, is at your expense.

What Does This Warranty Not Cover? and

How Does Your State Law Relate To This Warranty?

There is no other express warranty except for special emission system coverage on some products and as described above. This express warranty does not cover:

- Cost of regular maintenance service or parts, such as filters, fuel, lubricants, tune-up parts, blade sharpening, brake and clutch adjustments.
- Any product or part which has been altered or misused or required replacement or repair due to normal wear, accidents, or lack of proper maintenance.
- Repairs necessary due to improper fuel, contaminants in the fuel system, or failure to properly prepare the fuel system prior to any period of non-use over three months.
- Pickup and delivery charges for distances beyond a 15-mile radius from a TORO ProLine Service Dealer.

All repairs covered by this warranty must be performed by a TORO Service Dealer using Toro approved replacement parts.

The Toro Company is not liable for indirect or consequential damages in connection with the use of the TORO Products covered by this warranty, including any cost or expense of providing substitute equipment or service during reasonable periods of malfunction or non-use pending completion of repairs under this warranty. Some states do not allow exclusions of incidental or consequential damages, so the above exclusion may not apply to you.

This warranty gives you specific legal rights, and you may also have other rights which vary from state to state.

COUNTRIES OTHER THAN THE UNITED STATES OR CANADA

Customers who have purchased TORO products exported from the United States or Canada should contact their TORO Distributor (Dealer) to obtain guarantee policies for your country, province, or state. If for any reason you are dissatisfied with your Distributor's service or have difficulty obtaining guarantee information, contact the TORO importer. If all other remedies fail, you may contact us at The Toro Company.