



Wheel Horse[®]

12-32 XL Lawn Tractor

71199—200000001 & Up

PROTOTYPE

Operator's Manual

Introduction

Thank you for purchasing a Toro product.

All of us at Toro want you to be completely satisfied with your new product, so feel free to contact your local Authorized Service Dealer for help with service, genuine replacement parts, or other information you may require.

Whenever you contact your Authorized Service Dealer or the factory, always know the model and serial numbers of your product. These numbers will help the Service Dealer or Service Representative provide exact information about your specific product. You will find the model and serial number plate located in a unique place on the product as shown below.

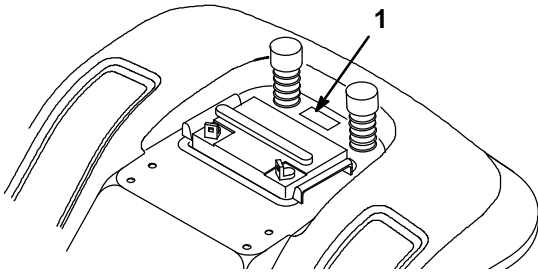

1. Model and Serial Number Plate (under the seat)

For your convenience, write the product model and serial numbers in the space below.

Model No:	_____
Serial No.	_____

Read this manual carefully to learn how to operate and maintain your product correctly. Reading this manual will help you and others avoid personal injury and damage to the product. Although we design, produce and market safe, state-of-the-art products, you are responsible for using the product properly and safely. You are also responsible for training persons, who you allow to use the product, about safe operation.

The warning system in this manual identifies potential hazards and has special safety messages that help you and others avoid personal injury, even death. DANGER, WARNING and CAUTION are signal words used to identify the level of hazard. However, regardless of the hazard, be extremely careful.

DANGER signals an extreme hazard that will cause serious injury or death if the recommended precautions are not followed.

WARNING signals a hazard that may cause serious injury or death if the recommended precautions are not followed.

CAUTION signals a hazard that may cause minor or moderate injury if the recommended precautions are not followed.

Two other words are also used to highlight information. “Important” calls attention to special mechanical information and “Note” emphasizes general information worthy of special attention.

The left and right side of the machine is determined by sitting on the seat in the normal operator’s position.

	WARNING:	
<p>The engine exhaust from this product contains chemicals known to the State of California to cause cancer, birth defects, or other reproductive harm.</p>		

IMPORTANT: This engine is not equipped with a spark arrester muffler. It is a violation of California Public Resource Code Section 4442 to use or operate this engine on any forest-covered, brush-covered or grass-covered land. Other states or federal areas may have similar laws.

Contents

	Page		Page
Safety	2	Installing the Discharge Cover	17
Safe Operating Practices	2	Tips for Mowing Grass	18
Toro Riding Mower Safety	4	Maintenance	19
Slope Chart	5	Service Interval Chart	19
Safety and Instruction Decals	7	Greasing and Lubrication	20
Gasoline and Oil	8	Tire Pressure	21
Recommended Gasoline	8	Brake	21
Stabilizer/Conditioner	9	Wiring Diagram	22
Filling the Fuel Tank	9	Fuse	23
Check Engine Oil Level	9	Headlights	23
Operation	10	Battery	24
Think Safety First	10	Spark Plug	26
Controls	10	Fuel Tank	27
Parking Brake	10	Fuel Filter	27
Positioning the Seat	11	Air Cleaner	28
Headlights	11	Engine Oil	30
Using the Blade Control (PTO)	11	Cutting Blade	31
Setting the Height-of-Cut	12	Removing the Mower	33
Starting and Stopping the Engine	12	Installing the Mower	35
The Safety System	13	Blade Drive Belt	36
Operating-in-Reverse	14	Side-to-Side Mower Leveling	37
Testing the Safety System	15	Front-to-Rear Blade Slope	38
Driving Forward or Backward	16	Washing Underside of Mower	40
Selecting Ground Speeds	16	Cleaning and Storage	41
Stopping the Machine	16	Troubleshooting	43
Side Discharge or Mulch Grass	17		

The enclosed Engine Owner's Manual is supplied for information regarding The U.S. Environmental Protection Agency (EPA) and the California Emission Control Regulation of emission systems, maintenance and warranty.

Keep this engine Owner's Manual with your unit. Should this engine Owner's Manual become damaged or illegible, replace immediately. Replacements may be ordered through the engine manufacturer.

Safety

This machine meets or exceeds the B71.1–1998 specifications of the American National Standards Institute, in effect at the time of production. However, improper use or maintenance by the operator or owner can result in injury. To reduce the potential for injury, comply with these safety instructions and always pay attention to the safety alert  symbol, which means CAUTION, WARNING, or DANGER—“personal safety instruction.” Failure to comply with the instruction may result in personal injury or death.

Safe Operating Practices

The following instructions are from ANSI standard B71.1—1998.

This product is capable of amputating hands and feet and throwing objects. Always follow all safety instructions to avoid serious injury or death.

General Operation

- Read, understand, and follow all instructions in the operator’s manual and on the machine before starting.
- Allow only responsible adults who are familiar with the instructions to operate the machine.
- Clear the area of objects such as rocks, toys, wire, etc., which could be picked up and thrown by the blade.
- Be sure the area is clear of other people before mowing. Stop the machine if anyone enters the area.
- Never carry passengers.
- Do not mow in reverse unless absolutely necessary. Always look down and behind before and while backing.
- Be aware of the mower discharge direction and do not point it at anyone. Do not operate the mower without either the entire grass catcher or the guard in place.
- Slow down before turning.
- Never leave a running machine unattended. Always turn off blades, set parking brake, stop engine, and remove keys before dismounting.
- Turn off blades when not mowing.
- Stop the engine before removing the grass catcher or unclogging the chute.
- Mow only in daylight or good artificial light.
- Do not operate the machine while under the influence of alcohol or drugs.
- Watch for traffic when operating near or crossing roadways.
- Use extra care when loading or unloading the machine into a trailer or truck.
- Always wear safety goggles or safety glasses with side shields when operating mower.
- Data indicates that operators, age 60 years and above, are involved in a large percentage of riding mower–related injuries. These operators should evaluate their ability to operate the riding mower safely enough to protect themselves and others from serious injury.

Slope Operation

Slopes are a major factor related to loss-of-control and tip-over accidents, which can result in severe injury or death. All slopes require extra caution. If you cannot back up the slope or if you feel uneasy on it, do not mow it.

- Mow up and down slopes, not across.
- Remove obstacles such as rocks, tree limbs, etc.
- Watch for holes, ruts or bumps. Uneven terrain could overturn the machine. Tall grass can hide obstacles.
- Use slow speed. Choose a low gear so that you will not have to stop or shift while on the slope.
- Follow Toro's recommendations for wheel weight or counterweights to improve stability.
- Use extra care with grass catchers or other attachments. These can change the stability of the machine.
- Keep all movement on slopes slow and gradual. Do not make sudden changes in speed or direction.
- Avoid starting or stopping on a slope. If tires lose traction, disengage the blades and proceed slowly straight down the slope.
- Do not turn on slopes unless necessary, and then, turn slowly and gradually downhill, if possible.
- Do not mow near drop-offs, ditches, or embankments. The machine could suddenly turn over if a wheel goes over the edge of a cliff or ditch, or if an edge caves in.
- Do not mow on wet grass. Reduced traction could cause sliding.
- Do not try to stabilize the machine by putting your foot on the ground.
- Do not use a grass catcher on steep slopes.

Children

Tragic accidents can occur if the operator is not alert to the presence of children. Children are often attracted to the machine and the mowing activity. Never assume that children will remain where you last saw them.

- Keep children out of the mowing area and under the watchful care of another responsible adult.
- Be alert and turn the machine off if children enter the area.
- Before and while backing, look behind and down for small children.
- Never carry children, even with the blades off. They may fall off and be seriously injured or interfere with safe machine operation.
- Never allow children to operate the machine.
- Use extra care when approaching blind corners, shrubs, trees, the end of a fence or other objects that may obscure vision.

Service

- Use extra care when handling gasoline and other fuels. They are flammable and vapors are explosive.
 - A. Use only an approved container.
 - B. Never remove the gas cap or add fuel when the engine is running. Allow the engine to cool before refueling. Do not smoke.
 - C. Never refuel the machine indoors.
 - D. Never store the machine or fuel container inside where there is an open flame, such as near a water heater or furnace.
- Never run a machine inside a closed area.
- Keep nuts and bolts tight, especially the blade attachment bolts. Keep equipment in good condition.

- Never tamper with safety devices. Check their proper operation regularly.
- Keep the machine free of grass, leaves, or other debris build-up. Clean up oil or fuel spillage. Allow the machine to cool before storing.
- Stop and inspect the equipment if you strike an object. Repair, if necessary, before restarting.
- Grass catcher components are subject to wear, damage and deterioration, which could expose moving parts or allow objects to be thrown. Frequently check components and replace with manufacturer's recommended parts, when necessary.
- Mower blades are sharp and can cut. Wrap the blade(s) or wear gloves, and use extra caution when servicing them.
- Use only genuine Toro replacement parts to ensure that original standards are maintained.
- Slow down before turning. Sharp turns on any terrain may cause loss of control.
- Never leave a running machine unattended. Always turn off blades, set parking brake, stop engine, and remove the ignition and "Key Choice" keys before dismounting.
- Keep hands, feet, hair and loose clothing away from attachment discharge area, underside of mower and any moving parts while engine is running.
- Do not touch equipment or attachment parts which may be hot from operation. Allow to cool before attempting to maintain, adjust or service.
- Remove obstacles such as rocks, tree limbs, etc. from the mowing area. Watch for holes, ruts or bumps, as uneven terrain could overturn the machine. Tall grass can hide obstacles.
- Battery acid is poisonous and can cause burns. Avoid contact with skin, eyes and clothing. Protect your face, eyes and clothing when working with a battery.
- Battery gases can explode. Keep cigarettes, sparks and flames away from battery.
- Use only genuine replacement parts to ensure that original standards are maintained.
- Mow up and down slopes greater than 5°, not across.
- Mow downhill only on slopes above 10°, never mow uphill. If a steep slope must be ascended, back up the hill, and drive forward down the hill, keeping the machine in gear.
- Do not operate machine on hillsides or slopes exceeding 15°.
- Avoid turning on slopes. If you must turn, turn slowly and gradually downhill, if possible.
- Do not use a grass catcher on steep slopes. Heavy grass bags could cause loss of control or overturn the machine.

Toro Riding Mower Safety

The following list contains safety information specific to Toro products or other safety information that you must know that is not included in the ANSI standards.

 **WARNING**

POTENTIAL HAZARD

- **Engine exhaust contains carbon monoxide, which is an odorless, deadly poison.**

WHAT CAN HAPPEN

- **Carbon monoxide can kill you and is also known to the State of California to cause birth defects.**

HOW TO AVOID THE HAZARD

- **Do not run engine indoors or in an enclosed area.**

- Stop the engine, disconnect spark plug wire(s) and remove key before performing any service, repairs, maintenance or adjustments.

Slope Chart

Read all safety instructions on pages 2-4.

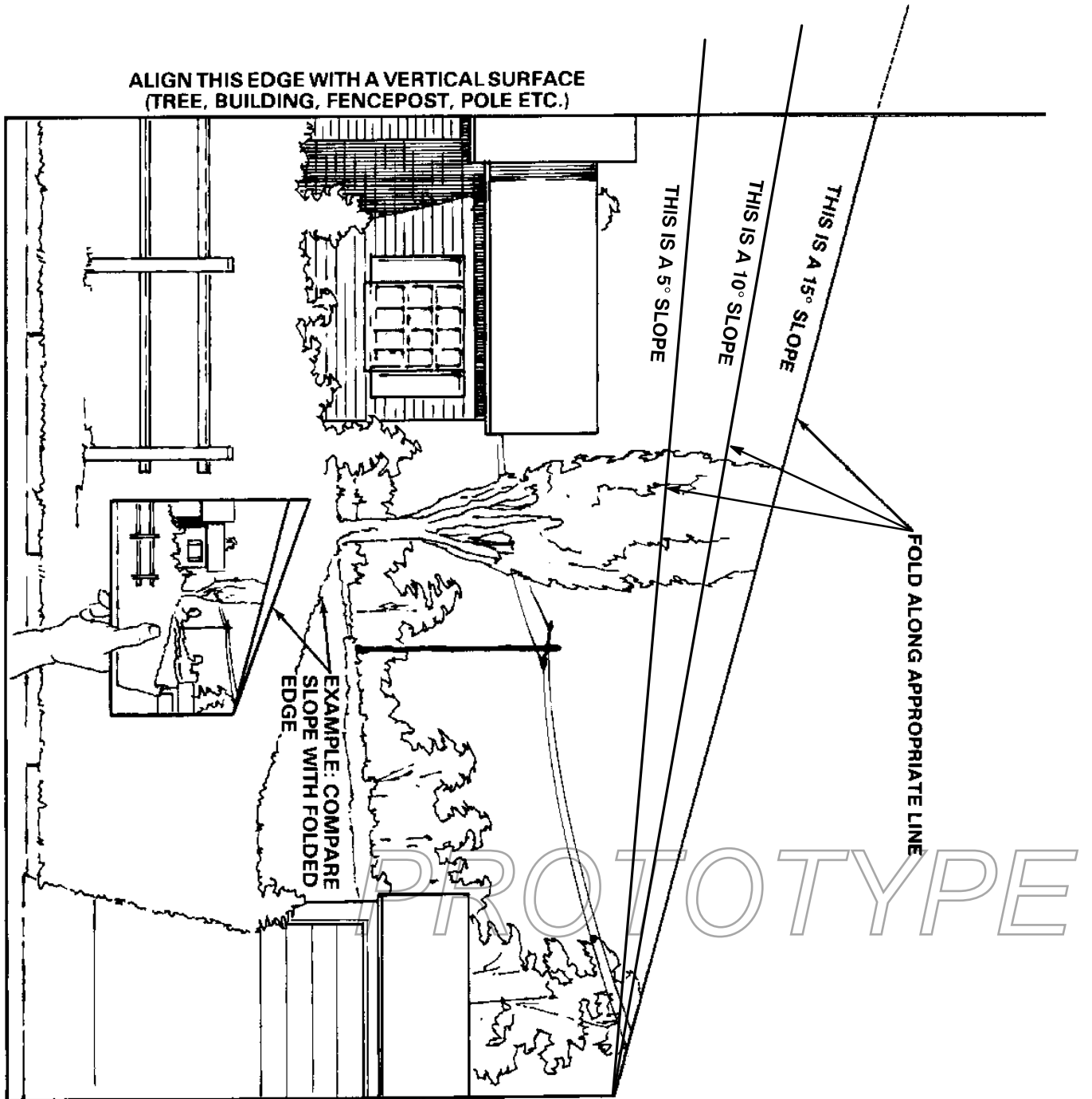

PROTOTYPE

Safety and Instruction Decals



Safety decals and instructions are easily visible to the operator and are located near any area of potential danger. Replace any decal that is damaged or lost.

ON GRASS DEFLECTOR AND ON MOWER RIGHT SIDE (Part No. 93-1122)



ON MOWER LEFT SIDE (Part No. 66-1340)



ALONGSIDE MOWER LIFT BRACKETS (Part No. 55-4300)

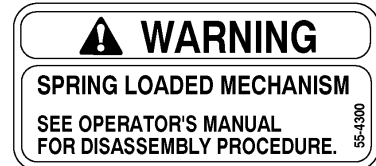

ON SEAT BRACKET (Part No. 99-5339)

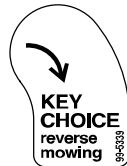

UNDER GRASS DEFLECTOR (Part No. 68-3650)



ON STEERING TOWER (Part No. 92-2462)

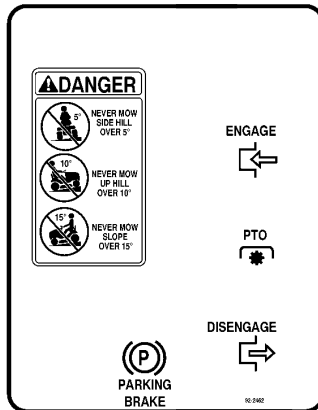

ON DASH RIGHT SIDE (Part No. 99-8140)

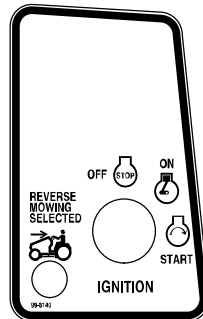

ON DASH LEFT SIDE (Part No. 92-2461)

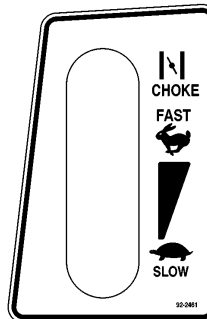

ON FRAME STEP (Part No. 99-6094)

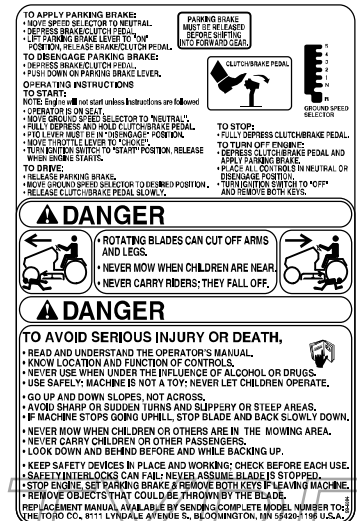

UNDER HOOD (Part No. 100-6220)

ON SEAT BRACKET (Part No. 99-2985)



XL SERIES QUICK REFERENCE AID SEE OPERATOR'S MANUAL

MODEL NUMBER	71199 / 12-32XL		
PART NUMBERS			
DRIVE/TRANS BELT	94-4291		
DECK BELT	88-6260		
OIL FILTER			
AIR ELEMENT	493903		
AIR PRE-CLEANER			
SPARK PLUG	802592		
SUGGESTED MAINTENANCE			
A. ENGINE OIL	CHECK EVERY 5 HOURS		CHANGE
B. GREASE CHASSIS	24HRS/STORAGE SERVICE		REPLACE
C. AIR CLEANER	FOAM SERVICE		PAPER/REPLACE
D. BATTERY	CHECK ELECTROLYTE	CHARGE SERVICE	

PERFORM ALL SCHEDULED MAINTENANCE WORKS OFF IN DUSTY, DIRTY CONDITIONS

For complete maintenance schedules refer to your Toro Wheel Horse Owners Manual. For dealer location and more information on Toro products, contact: www.toro.com

100-6220

Gasoline and Oil

Recommended Gasoline

Use UNLEADED Regular Gasoline suitable for automotive use (85 pump octane minimum). Leaded regular gasoline may be used if unleaded regular is not available.

IMPORTANT: Never use methanol, gasoline containing methanol, or gasohol containing more than 10% ethanol because the fuel system could be damaged. Do not mix oil with gasoline.

DANGER

POTENTIAL HAZARD

- In certain conditions gasoline is extremely flammable and highly explosive.

WHAT CAN HAPPEN

- A fire or explosion from gasoline can burn you, others, and cause property damage.

HOW TO AVOID THE HAZARD

- Use a funnel and fill the fuel tank outdoors, in an open area, when the engine is cold. Wipe up any gasoline that spills.
- Do not fill the fuel tank completely full. Add gasoline to the fuel tank until the level is 1/4" to 1/2" (6 mm to 13 mm) below the bottom of the filler neck. This empty space in the tank allows gasoline to expand.
- Never smoke when handling gasoline, and stay away from an open flame or where gasoline fumes may be ignited by a spark.
- Store gasoline in an approved container and keep it out of the reach of children. Never buy more than a 30-day supply of gasoline.

DANGER

POTENTIAL HAZARD

- In certain conditions gasoline is extremely flammable and highly explosive.

WHAT CAN HAPPEN

- A fire or explosion from gasoline can burn you, others, and cause property damage.

HOW TO AVOID THE HAZARD

- Always place gasoline containers on the ground away from your vehicle before filling.
- Do not fill gasoline containers inside a vehicle or on a truck or trailer bed because interior carpets or plastic truck bed liners may insulate the container and slow the loss of any static charge.
- When practical, remove gas-powered equipment from the truck or trailer and refuel the equipment with its wheels on the ground.
- If this is not possible, then refuel such equipment on a truck or trailer from a portable container, rather than from a gasoline dispenser nozzle.
- If a gasoline dispenser nozzle must be used, keep the nozzle in contact with the rim of the fuel tank or container opening at all times until fueling is complete.

PROTOTYPE

Stabilizer/Conditioner

Using a stabilizer/conditioner in the machine:

- Keeps gasoline fresh during storage of 90 days or less. For longer storage it is recommended that the fuel tank be drained.
- Cleans the engine while it runs
- Eliminates gum-like varnish buildup in the fuel system, which causes hard starting

IMPORTANT: Never use fuel additives containing methanol or ethanol.

Add the correct amount of gas stabilizer/conditioner to the gas.

Note: A fuel stabilizer/conditioner is most effective when mixed with fresh gasoline. To minimize the chance of varnish deposits in the fuel system, use fuel stabilizer at all times.

Filling the Fuel Tank

1. Shut the engine off and set the parking brake.
2. Clean around each fuel tank cap and remove the cap. Add unleaded regular gasoline to both fuel tanks, until the level is 1/4 to 1/2 inch (6 mm to 13 mm) below the bottom of the filler neck. This space in the tank allows gasoline to expand. Do not fill the fuel tanks completely full.
3. Install fuel tank caps securely. Wipe up any gasoline that may have spilled.
4. Fuel gauge is located in right side tank.

Check Engine Oil Level

Before you start the engine and use the machine, check the oil level in the engine crankcase; refer to Checking Oil Level, page 30.

PROTOTYPE

Operation

Think Safety First

Please carefully read all the safety instructions and symbols in the safety section. Knowing this information could help you, your family, pets or bystanders avoid injury.

Controls

Become familiar with all the controls (Fig. 1) before you start the engine and operate the machine.

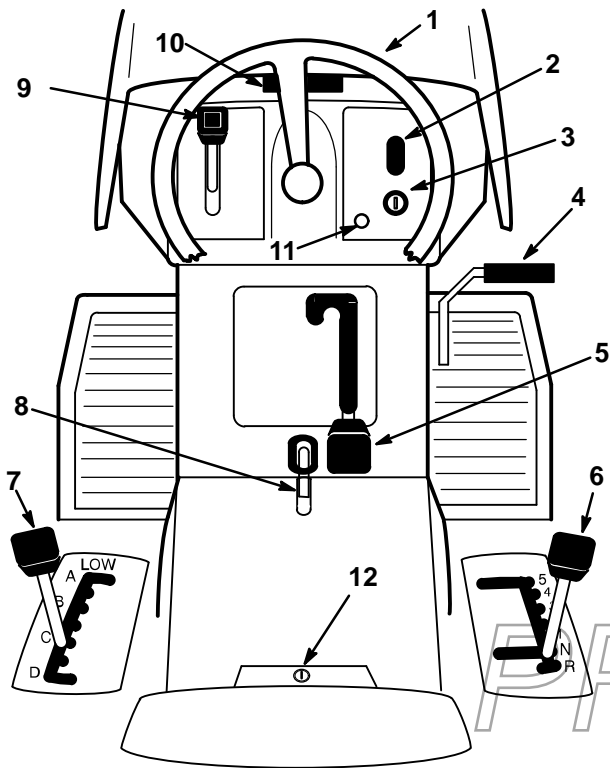

Figure 1

- | | |
|--|------------------------------------|
| 1. Steering wheel | 7. Height-of-cut lever (deck lift) |
| 2. Light switch—on/off (selected models) | 8. Parking brake lever |
| 3. Ignition switch | 9. Throttle lever |
| 4. Clutch/brake pedal | 10. Hood opening |
| 5. Blade control (PTO) | 11. Operating-in-Reverse light |
| 6. Ground speed selector | 12. Key Choice™ switch |

Parking Brake

Always set the parking brake when you stop the machine or leave it unattended.

Setting the Parking Brake

1. Push the clutch/brake pedal (Fig. 2) down and hold it in the depressed position.
2. Lift the parking brake lever (Fig. 2) up and gradually take your foot off the clutch/brake pedal. The clutch/brake pedal should stay in the depressed (locked) position.

Releasing the Parking Brake

1. Push down on the clutch/brake pedal (Fig. 2). The parking brake lever should release.
2. Gradually release the clutch/brake pedal.

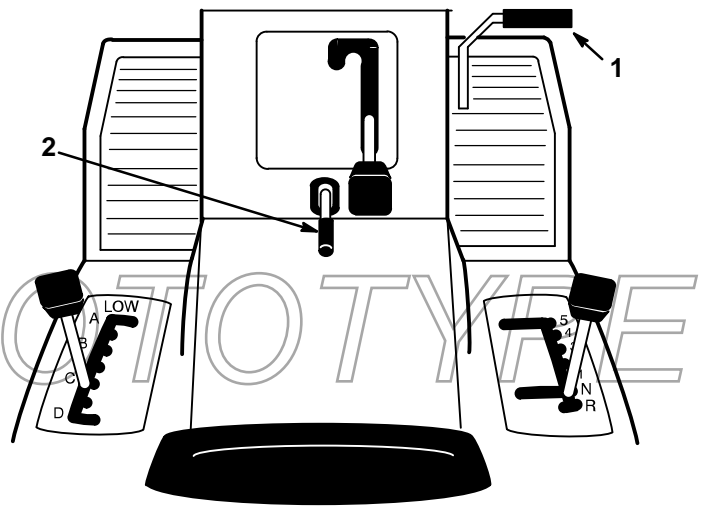

Figure 2

- | | |
|-----------------------|------------------------|
| 1. Clutch/brake pedal | 2. Parking brake lever |
|-----------------------|------------------------|

m-1880

Positioning the Seat

The seat can move forward and backward. Position the seat where you have the best control of the machine and are most comfortable.

1. Raise the seat and loosen the adjustment knob (Fig. 3).
2. Move the seat to the desired position and tighten the knob.

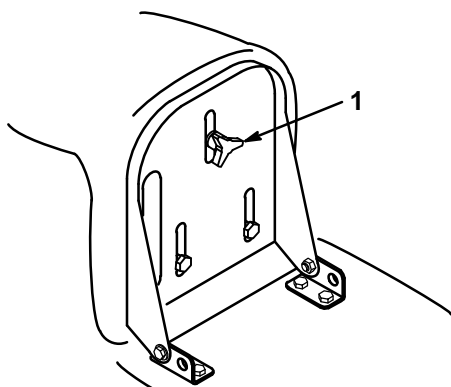

m-1862

Figure 3

1. Adjustment knob

Headlights

Headlights are optional on some models. A dash-mounted “ON/OFF” switch (Fig. 1) controls the headlights. The lights only shine while the engine is running and the switch is “ON.”

Using the Blade Control (PTO)

The blade control (PTO) engages and disengages power to the blade(s).

Engaging the Blade(s)

1. Depress the clutch/brake pedal to stop the machine.
2. Move the blade control (PTO) to “ENGAGED” (Fig. 4).

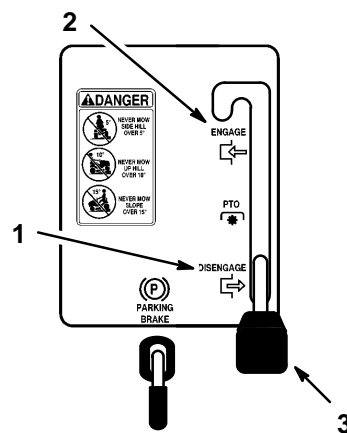

m-1852

Figure 4

1. Disengaged
2. Engaged
3. Blade control (PTO)

PROTOTYPE

Disengaging the Blade(s)

1. Depress the clutch/brake pedal to stop the machine.
2. Move the blade control (PTO) to “DISENGAGED” (Fig. 4).

Setting the Height-of-Cut

The height-of-cut lever (deck lift) is used to raise and lower the mower to the desired cutting height.

1. The cutting height may be set in one of seven positions from approximately 1 to 4 inches (25 to 102 mm).
2. Pull on the height-of-cut lever (deck lift) and move it to the desired position (Fig. 5).

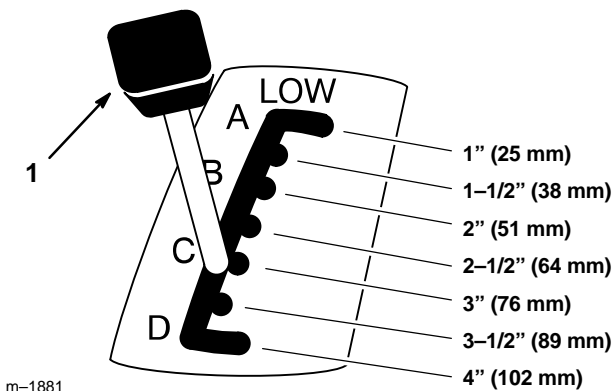

Figure 5

1. Height-of-cut lever (deck lift)

Starting and Stopping the Engine

Starting

1. Sit down on the seat.
2. Set the parking brake; refer to Setting the Parking Brake, page 10.

Note: The engine will not start unless you set the parking brake or fully depress the clutch/brake pedal.

3. Move the ground speed selector into neutral “N” (Fig. 6).
4. Move the blade control (PTO) to “DISENGAGED” (Fig. 7).
5. Move the throttle lever to “CHOKE” (Fig. 8).

Note: An engine that has been running and is warm may not require step 5.

6. Turn the ignition key clockwise and hold it in the “START” position (Fig. 9). When the engine starts, release the key.

IMPORTANT: If the engine does not start after 30 seconds of continuous cranking, turn the ignition key to “OFF” and let the starter motor cool; refer to Troubleshooting, page 43.

7. After the engine starts, slowly move the throttle lever to “FAST” (Fig. 8). If the engine stalls or hesitates, move the throttle lever back to “CHOKE” for a few seconds. Then move the throttle lever to “FAST.” Repeat this as required.

PROTOTYPE

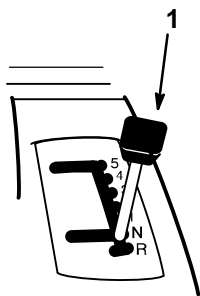

Figure 6

1. Ground speed selector

m-1893

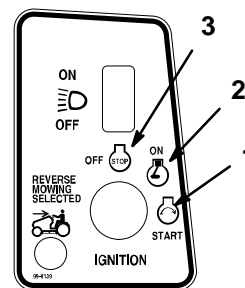

Figure 9

1. Start
2. On
3. Off

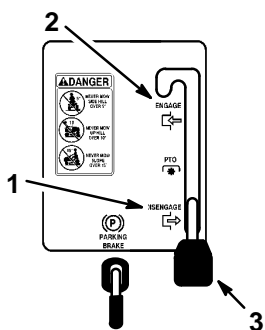

Figure 7

1. Disengaged
2. Engaged
3. Blade control (PTO)

m-1852

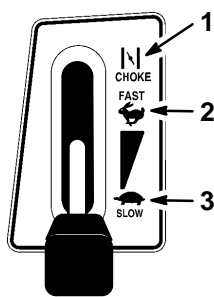

Figure 8

1. Choke
2. Fast
3. Slow

m-1859

Stopping

1. Move the throttle lever to “SLOW” (Fig. 8).
2. Turn the ignition key to “OFF” (Fig. 9).

Note: If the engine has been working hard or is hot, let it idle for a minute before turning the ignition key “OFF.” This helps cool the engine before it is stopped. In an emergency, the engine may be stopped by turning the ignition key to “OFF.”

The Safety System

Understanding the Safety System

The safety system is designed to prevent the engine from starting unless:

- The clutch/brake pedal is depressed
- The blade control (PTO) is “DISENGAGED”

The safety system is designed to stop the engine if:

- You rise from the seat when the clutch/brake pedal is released.
- You rise from the seat when the blade (PTO) is “ENGAGED.”
- You shift into reverse with the power take off (PTO) engaged and the operating-in-reverse interlock not deactivated.

Operating-in-Reverse

An interlock feature is provided that prevents the Power Take Off (PTO) from operating while the tractor is traveling in reverse. If the unit is shifted into reverse while the mower blade or other PTO driven attachment is engaged, the engine will stop.

Do not mow while backing up unless it is absolutely necessary. If you need to mow while in reverse gear or use other PTO driven attachments (such as a snowthrower or tiller), this no operating-in-reverse interlock may be temporarily deactivated.

Before deactivating this interlock, be sure there are no children present on or near the property where you are using the tractor, and that none are likely to appear while you are mowing or operating an attachment. Be extra observant after you have chosen to deactivate the interlock because the sound of the tractor's engine might prevent you from being aware that a child or a bystander has entered the area where you are operating the tractor.

If you are certain that you can safely mow in reverse or operate an attachment, deactivate the no operating-in-reverse interlock by turning the Key Choice™ switch (Fig. 10), located on the seat bracket on the right hand side just below the seat, after engaging the blade (PTO). A red light on the front console (Fig. 11) will turn on as a reminder that the no operating-in-reverse interlock has been deactivated. Once the interlock is deactivated it stays in this mode—with your mower blade or PTO-driven attachment operating whenever you back up—and the console light stays on until either the blade (PTO) is disengaged, or the engine is turned off.

Note: Do not insert the “Key Choice” key unless it is absolutely necessary to mow in reverse or operate an attachment. The “Key Choice” key should also be removed from the unit if it will be operated by someone other than a responsible, experienced operator. This will prevent the unit from operating in reverse with the mower blade or other PTO attachment engaged. Always remove both the ignition and the “Key Choice” keys and put them in a safe place out of the reach of children when leaving the unit unattended.

DANGER

POTENTIAL HAZARD

- **A child or bystander could be backed over by a riding mower with its blade(s) engaged.**

WHAT CAN HAPPEN

- **Blade contact will cause serious personal injury or death.**

HOW TO AVOID THE HAZARD

- **Do not mow in reverse unless absolutely necessary.**
- **Always look backward and down before backing up.**
- **Use “Key Choice” switch only if you are certain no children or other bystanders will appear in the mowing area.**
- **Always remove both the ignition and “Key Choice” keys and put them in a safe place out of the reach of children or unauthorized users when leaving the unit unattended.**

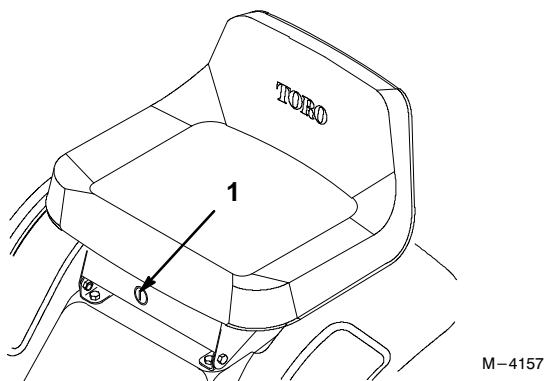

Figure 10

1. "Key Choice" switch

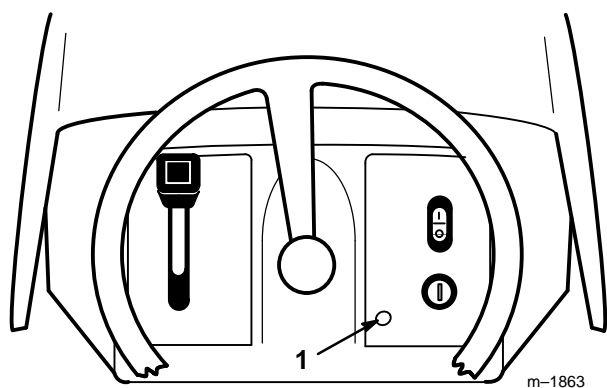

Figure 11

1. Operating-in-Reverse light

Testing the Safety System

Test the safety system before you use the machine each time. If the safety system does not operate as described below, have an Authorized Service Dealer repair the safety system immediately.

1. Move the ground speed selector into neutral "N." Set the parking brake. Move the blade control (PTO) to "ENGAGED." Now turn the ignition key to "START"; the engine should not crank.
2. With the ground speed selector in neutral "N," move the blade control (PTO) to "DISENGAGED" and release the parking brake. Now turn the ignition key to "START"; the engine should not crank.
3. With the ground speed selector in neutral "N," set the parking brake and move the blade control (PTO) to "DISENGAGED." Now start the engine. While the engine is running, release the parking brake and rise slightly from the seat; the engine should stop.
4. Put the PTO lever in the "disengage" position and the gear shifter in neutral. Now start the engine. While the engine is running, move the PTO lever to the "engage" position, push in the clutch and put the gear shifter in reverse. The engine should stop.
5. Put the PTO lever in the "disengage" position and the gear shifter in neutral. Now start the engine. Move the PTO lever to the "engage" position and turn the "Key Choice" key and release. The Operating-in-Reverse warning light should illuminate. Move the PTO lever to the "disengage" position and the Operating-in-Reverse warning light should turn off.

PROTOTYPE

Driving Forward or Backward

The throttle control regulates the engine speed as measured in rpm (revolutions per minute).

To go forward or backward, depress the clutch/brake pedal. Move the ground speed selector to the desired forward speed or reverse. As you slowly release the pedal, the machine will begin to move. Steer the machine with the steering wheel.

Note: For reverse motion, with the PTO engaged, the operating-in-reverse interlock must be deactivated by the key choice switch located in front of and below the seat.

CAUTION

POTENTIAL HAZARD

- If you release the clutch/brake pedal too quickly when the ground speed selector is in gear, you could suddenly put the machine in motion.

WHAT CAN HAPPEN

- Sudden engagement of the machine's drive system could cause you to lose control.

HOW TO AVOID THE HAZARD

- Always release the clutch/brake pedal slowly when starting the machine in motion (forward or reverse).

IMPORTANT: Do not shift on slopes. Choose a slow speed so that you will not have to stop or shift while on the slope.

Stopping the Machine

To stop the machine, depress the clutch/brake pedal, shift into neutral, disengage the blade control (PTO), and turn the ignition key to "OFF" to stop the engine. Also set the parking brake if you leave the machine unattended; refer to Setting the Parking Brake, page 10. Remember to remove the keys from the ignition and "key choice" switches.

CAUTION

POTENTIAL HAZARD

- Someone could move or attempt to operate the tractor while it is unattended.

WHAT CAN HAPPEN

- Children or bystanders may be injured if they use the tractor.

HOW TO AVOID THE HAZARD

- Always remove the ignition and "Key Choice" keys and set the parking brake when leaving the machine unattended, even if just for a few minutes.

IMPORTANT: To prevent excessive wear, do not "Ride the Brakes". Shift to a lower speed for slower ground speed. Choose a slow speed so that you will not have to stop or shift while on the slope.

Selecting Ground Speeds

IMPORTANT: To avoid transmission damage, always depress the clutch/brake pedal before shifting into or out of reverse.

Always start the machine in motion by depressing the clutch/brake pedal and shifting into the desired speed. Once the machine is in motion, you can shift into any forward speed without depressing the clutch/brake pedal. In most conditions, the machine is powerful enough to move out in any speed. If it will not move out in a selected speed (i.e., #5) due to a heavy load, use a lower speed (i.e., #2).

Side Discharge or Mulch Grass

DANGER

POTENTIAL HAZARD

- Without the grass deflector, discharge cover, or complete grass catcher assembly mounted in place, you and others are exposed to blade contact and thrown debris.

WHAT CAN HAPPEN

- Contact with rotating mower blade(s) and thrown debris will cause injury or death.

HOW TO AVOID THE HAZARD

- NEVER remove the grass deflector from the mower because the grass deflector routes material down toward the turf. If the grass deflector is ever damaged, replace it immediately.
- Never put your hands or feet under the mower.
- Never try to clear discharge area or mower blades unless you move the blade control (PTO) to “DISENGAGED” and rotate the ignition key to “OFF.” Also remove the key and pull the wire off the spark plug.

1. The mower has a hinged grass deflector that disperses clippings to the side and down toward the turf.
2. To mulch grass clippings you must install the discharge cover (optional on some models) into the opening in the side of the mower; refer to Installing the Discharge Cover, page 17.

Installing the Discharge Cover

To convert from side discharge to a mulching mower, install the discharge cover into the opening at the side of the mower.

1. Shut the engine off and remove the ignition key.
2. Lift the grass deflector and place the discharge cover over the opening onto the lower lip of the mower and slide into the front hinge (Fig. 12).
3. Slide the hinge pin through the hinge (Fig. 12).
4. Secure the discharge cover to the mower with the wing nut (Fig. 12).

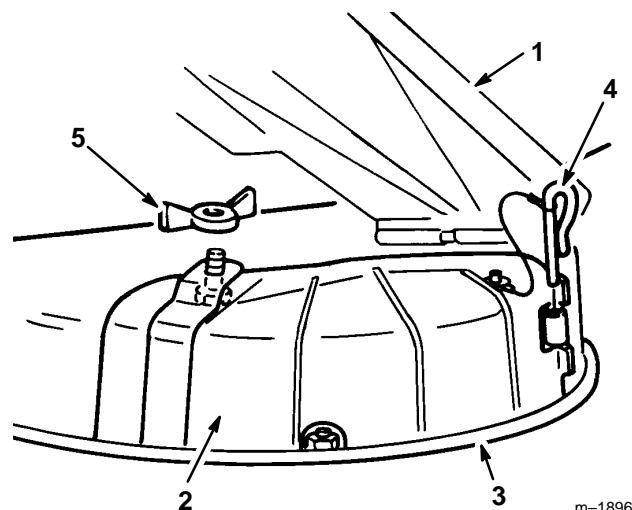

Figure 12

- | | |
|--------------------|--------------|
| 1. Grass deflector | 4. Hinge pin |
| 2. Discharge cover | 5. Wing nut |
| 3. Lower lip | |

5. To convert back to a side discharge mower, remove the discharge cover and lower the grass deflector over the discharge opening.

m-1896

Tips for Mowing Grass

Fast Throttle Setting

For best mowing and maximum air circulation, operate the engine at “FAST.” Air is required to thoroughly cut grass clippings, so do not set the height-of-cut too low or totally surround the mower by uncut grass. Always try to have one side of the mower free from uncut grass, which allows air to be drawn into the mower.

Using the mower for the First Time

Cut grass slightly longer than normal to ensure the cutting height of the mower does not scalp any uneven ground. However, the cutting height used in the past is generally the best one to use. When cutting grass longer than six inches tall, you may want to cut the lawn twice to assure an acceptable quality-of-cut.

Cut 1/3 of the Grass Blade

It is best to cut only about 1/3 of the grass blade. Cutting more than that is not recommended, unless grass is sparse or it is late fall when grass grows more slowly.

Mowing Direction

Alternate mowing direction to keep the grass standing straight. This also helps disperse clippings which enhances decomposition and fertilization.

Mow at Correct Intervals

Normally, mow every 4 days. But remember, grass grows at different rates at different times. So to maintain the same cutting height, which is a good practice, mow more often in early spring. As the grass growth rate slows in mid summer, mow less frequently. If you cannot mow for an extended period, first mow at a high cutting height; then mow again 2 days later at a lower height setting.

Avoid Cutting Too Low

If the cutting width of the mower is wider than the mower you previously used, raise the cutting height one notch to ensure uneven turf is not cut too short.

Long Grass

If the grass is ever allowed to grow slightly longer than normal, or if it contains a high degree of moisture, raise the cutting height higher than usual and cut the grass at this setting. Then cut the grass again using the lower, normal setting.

When Stopping

If the machine’s forward motion must be stopped while mowing, a clump of grass clippings may drop onto your lawn. To avoid this:

1. With the blade(s) “ENGAGED,” move onto a previously cut area.
2. To disperse the clippings evenly, raise the mower one or two height-of-cut settings while driving forward with the blade(s) “ENGAGED.”

Keep the Underside of the Mower Clean

Use the washout port to clean clippings and dirt from the underside of the mower after each use. If grass and dirt build up inside the mower, cutting quality will eventually become unsatisfactory.

Blade Maintenance

Maintain a sharp blade throughout the cutting season because a sharp blade cuts cleanly without tearing or shredding the grass blades. Tearing and shredding turns grass brown at the edges, which slows growth and increases the chance of disease. Every 30 days, check the cutter blade(s) for sharpness and file down any nicks.

PROTOTYPE

Maintenance

Service Interval Chart

Service Operation	Each Use	5 Hours	25 Hours	Storage Service	Spring Service	Notes
Oil—Initial change		X				
Oil—periodic change (50 hours or once each season)				X		
Oil—check level	X					
Safety System—check	X	X	X		X	
Cutter Blade—check		X	X	X		
Brake—check		X	X	X	X	
Chassis—grease			X	X		More often in dusty, dirty conditions
Foam Air Cleaner—service			X	X		
Paper Air Cleaner—replace				X		
Spark Plug—check			X	X	X	
Belts—check for wear/cracks				X		
Gasoline—drain				X		
Engine—clean outside			X	X		
Washing Underside of Mower	X			X		
Chipped Surfaces—paint				X		
Battery—check electrolyte		X		X	X	
Battery—charge, disconnect cables				X		
Fuel Filter—replace				X		
Tires—check pressure			X	X	X	

PROTOTYPE

⚠ CAUTION

POTENTIAL HAZARD

- If you leave the key in the ignition switch, someone could start the engine.

WHAT CAN HAPPEN

- Accidental starting of the engine could seriously injure you or other bystanders.

HOW TO AVOID THE HAZARD

- Remove the key from the ignition switch and pull the wire off the spark plug before you do any maintenance. Also push the wire aside so it does not accidentally contact the spark plug.

Greasing and Lubrication

Service Interval/Specification

Grease the machine after every 25 operating hours or once a year, whichever occurs first. Grease more frequently when operating conditions are extremely dusty or sandy.

Grease Type: General-purpose grease.

How to Grease

1. Disengage the blade control (PTO), shift into neutral, set the parking brake, and turn the ignition key to “OFF” to stop the engine.
2. Clean the grease fittings with a rag. Make sure to scrape any paint off the front of the fitting(s).
3. Connect a grease gun to the fitting. Pump grease into the fittings.
4. Wipe up any excess grease.

Where to Add Grease

1. Lubricate the front wheels and steering spindles until grease begins to ooze out the bearings (Fig. 13).

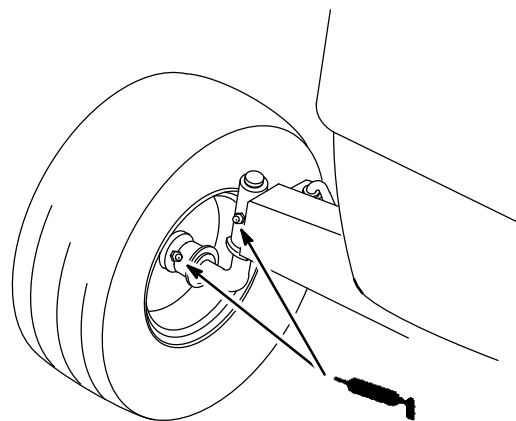

Figure 13

PROTOTYPE

Tire Pressure

Service Interval/Specification

Maintain the air pressure in the front and rear tires at 20 psi (138 kPa). Check the pressure at the valve stem after every 25 operating hours or yearly, whichever occurs first. Check the tires when they are cold to get the most accurate pressure reading.

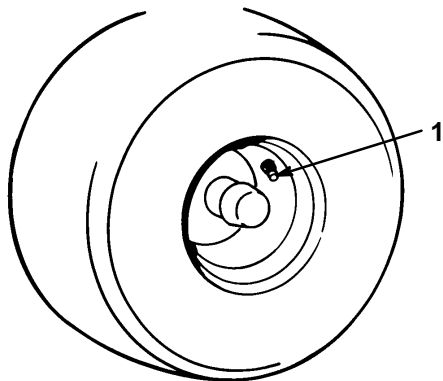

m-1872

Figure 14

1. Valve stem

Brake

The brake is on the right side of the rear axle, inside the rear tire (Fig. 15). If the brake does not hold securely or stopping power is insufficient, an adjustment is required.

Checking the Brake

1. Park the machine on a level surface, disengage the blade control (PTO), shift into neutral, set the parking brake, and turn the ignition key to "OFF" to stop the engine.
2. If the rear wheels lock and skid when you push the tractor forward, no adjustment is required. An adjustment is required if the wheels turn and do not lock; refer to Adjusting the Brake, page 21.

Adjusting the Brake

1. Check the brake before you adjust it; refer to Checking the Brake, page 21.
2. To increase braking resistance, tighten the brake adjusting nut (Fig. 15) 1/8 turn clockwise; then check the brake again. Continue this adjusting and checking process until the brake is set properly.
3. Push down on the clutch/brake pedal to release the parking brake.

IMPORTANT: With the parking brake released, the rear wheels must rotate freely when you push the tractor. If the brake seems to "drag," loosen the adjusting nut slightly until the wheels rotate freely. If both conditions cannot be achieved, contact an authorized service dealer immediately.

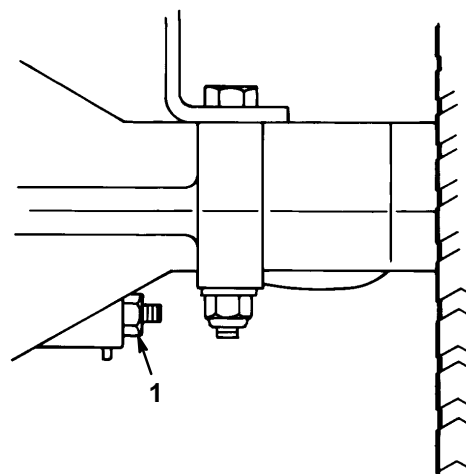

m-1895

Figure 15

1. Brake adjusting nut

Wiring Diagram

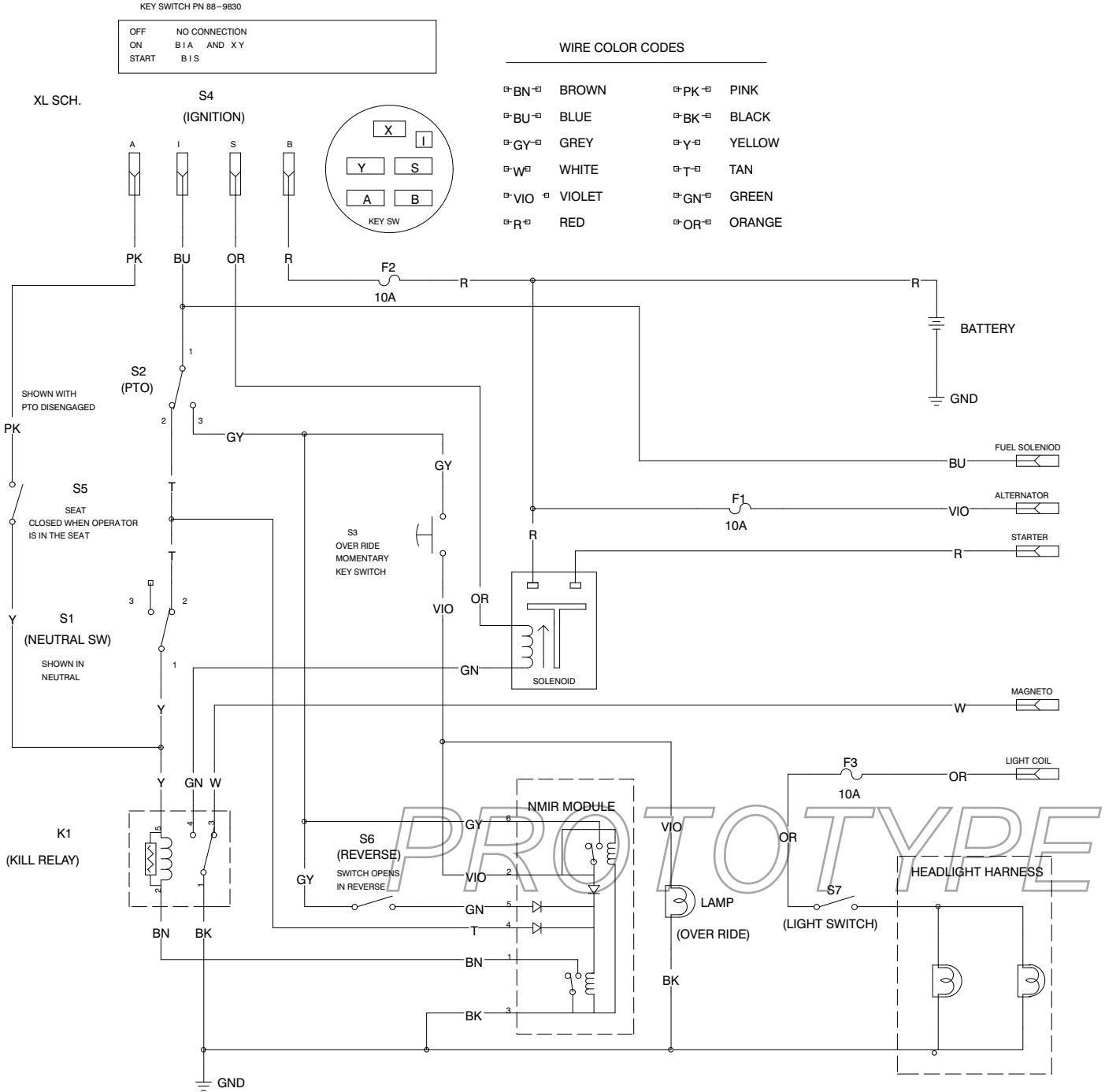

Fuse

Service Interval/Specification

The electrical system is protected by fuses. No maintenance is required, however, if a fuse blows check the circuit wiring for a short. To replace a fuse pull up (Fig. 16) to remove from socket. Push down to insert.

Fuses: 10 amp, blade-type.

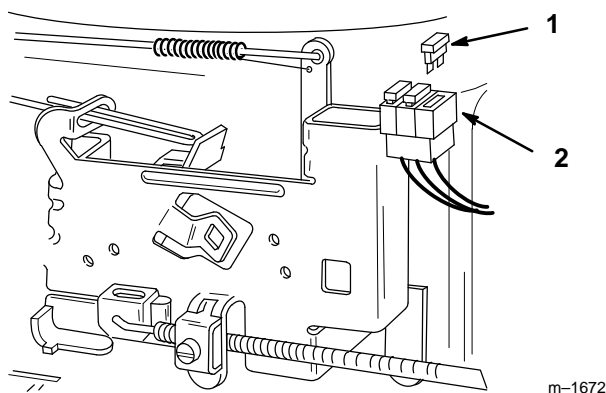

Figure 16

1. Fuse (removed) 2. Socket

Headlights

Specification: Bulb # 1156, automotive type.

Removing the Bulb

1. Disengage the blade control (PTO), shift into neutral, set the parking brake, and turn the ignition key to "OFF" to stop the engine.
2. Open the hood. Pull wire connectors off both bulb holder terminals.
3. Rotate the bulb holder 1/4 turn counterclockwise and remove it from the reflector (Fig. 17).
4. Push and rotate the bulb counterclockwise until it stops (approx. 1/4 turn) and remove bulb from the bulb holder (Fig. 18).

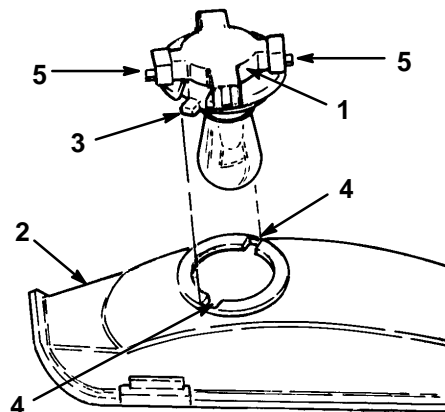

Figure 17

1. Bulb holder 4. Slots
2. Reflector 5. Terminals
3. Tabs

Installing the Bulb

1. The bulb has metal pins on the side of its base. Align the pins with the slots in the bulb holder and insert the base into the holder (Fig. 18). Push and rotate the bulb clockwise until it stops.

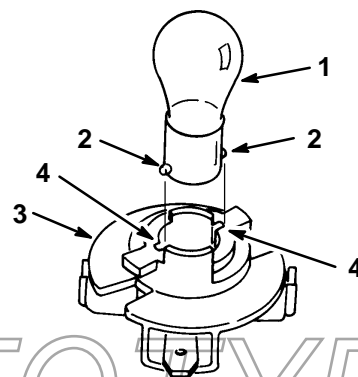

Figure 18

1. Bulb 3. Bulb holder
2. Metal pins 4. Slots

2. The bulb holder has two tabs (Fig. 17). Align the tabs with the slots in the reflector, insert the bulb holder into the reflector and rotate it 1/4 turn clockwise until it stops.
3. Push the wire connectors onto the terminals on the bulb holder.

Battery

Service Interval/Specification

Check the electrolyte level in the battery every 5 hours. Always keep the battery clean and fully charged. Use a paper towel to clean the battery and battery box. If the battery terminals are corroded, clean them with a solution of four parts water and one part baking soda. Apply a light coating of grease to the battery terminals to prevent corrosion.

Voltage: 12 v, 160 Cold Cranking Amps

Removing the Battery

1. Disengage the blade control (PTO), shift into neutral, set the parking brake, and turn the ignition key to "OFF" to stop the engine.
2. Tip the seat forward to see the battery.
3. Disconnect the negative (black) ground cable from the battery post (Fig. 19).
4. Slide the rubber cover up the positive (red) cable. Disconnect the positive (red) cable from the battery post (Fig. 19).
5. Remove the battery box, battery, and long vent tube from the chassis (Fig. 20).

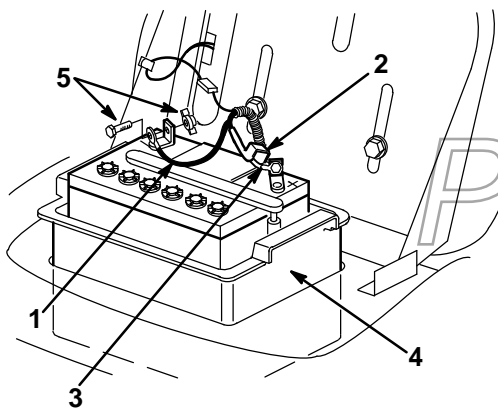

Figure 19

- | | |
|---------------------------|----------------------|
| 1. Negative cable (black) | 4. Battery box |
| 2. Rubber cover | 5. Bolt and wing nut |
| 3. Positive cable (red) | |

m-1876

Installing the Battery

1. Put the battery into the battery box and slide the vent tube into the channel and through the slot in the bottom of the box (Fig. 20).

IMPORTANT: Look down into the cut out area where the battery box fits into the chassis. Notice the hole at the end of the right frame member (Fig. 20). Always install the long battery vent tube through the hole to prevent battery acid from corroding the tractor and mower.

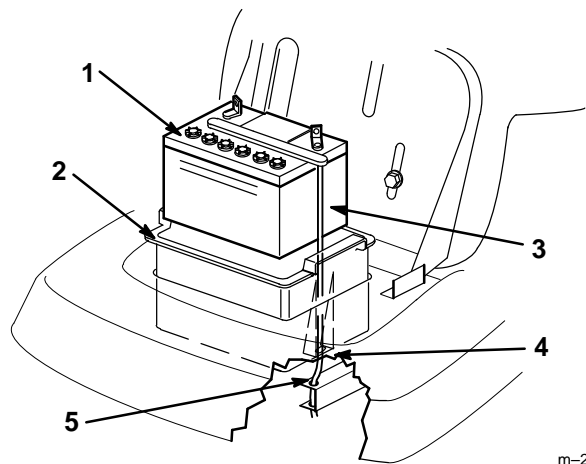

m-2347

Figure 20

- | | |
|----------------|------------------------|
| 1. Battery | 4. Slot in battery box |
| 2. Battery box | 5. Holes in frame |
| 3. Vent tube | |

2. Install the battery box and battery into the chassis (Fig. 20). Make sure to slide the end of the vent tube through the hole in the frame (Fig. 20).
3. Using the bolt and wing nut, connect the positive (red) cable to the positive (+) battery post (Fig. 19). Slide the rubber cover over the battery post.
4. Using the bolt and wing nut, connect the negative (black) cable to the negative (-) battery post (Fig. 19).

Checking Electrolyte Level

1. Tip the seat forward to see the battery.
2. Look at the side of the battery. The electrolyte must be up to the “UPPER” line (Fig. 21). Do not allow the electrolyte to get below the “LOWER” line (Fig. 21).
3. If the electrolyte is low, add the required amount of distilled water; refer to Adding Water to the Battery, page 25.

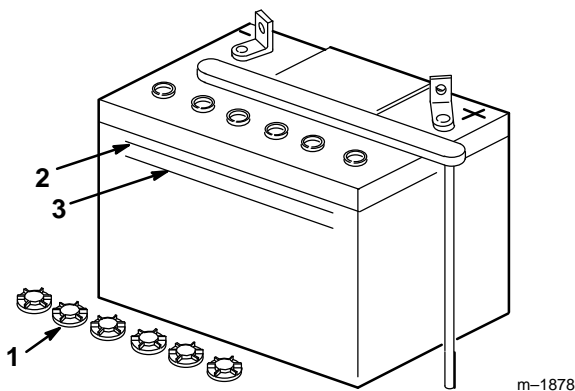

Figure 21

1. Filler caps
2. UPPER line
3. LOWER line

Adding Water to the Battery

The best time to add distilled water to the battery is just before you operate the machine. This lets the water mix thoroughly with the electrolyte solution.

1. Clean the top of the battery with a paper towel.
2. Unscrew the filler caps (Fig. 21).
3. Slowly pour distilled water into each battery cell until the level is up to the “UPPER” line (Fig. 21) on the battery case.

IMPORTANT: Do not overfill the battery because electrolyte (sulfuric acid) can cause severe corrosion and damage to the chassis.

4. Screw the filler caps onto the battery.

Charging the Battery

IMPORTANT: Always keep the battery fully charged (1.260 specific gravity). This is especially important to prevent battery damage when the temperature is below 32°F (0°C).

1. Remove the battery from the chassis; refer to Removing the Battery, page 24.
2. Check the electrolyte level; refer to Checking Electrolyte Level, page 25, steps 2–3.
3. Remove the filler caps from the battery and connect a 3 to 4 amp battery charger to the battery posts. Charge the battery at a rate of 4 amperes or less for 4 hours (12 volts). Do not overcharge the battery. Install the filler caps after the battery is fully charged.

! WARNING

POTENTIAL HAZARD

- Charging the battery produces gasses.

WHAT CAN HAPPEN

- Battery gasses can explode.

HOW TO AVOID THE HAZARD

- Keep cigarettes, sparks and flames away from battery.

4. Install the battery in the chassis; refer to Installing the Battery, page 24.

PROTOTYPE

Spark Plug

Service Interval/Specification

Install a new spark plug after every 100 operating hours. Check the spark plug after every 25 operating hours. Make sure the air gap between the center and side electrodes is correct before installing the spark plug. Use a spark plug wrench for removing and installing the spark plug and a gapping tool/feeler gauge to check and adjust the air gap.

Type: Champion RJ-19LM (or equivalent)

Air Gap: 0.030" (0.762 mm)

Removing the Spark Plug

1. Disengage the blade control (PTO), shift into neutral, set the parking brake, and turn the ignition key to "OFF" to stop the engine.
2. Open the hood.
3. Pull the wire off the spark plug (Fig. 22). Now clean around the spark plug to prevent dirt from falling into the engine and potentially causing damage.
4. Remove the spark plug and metal washer.

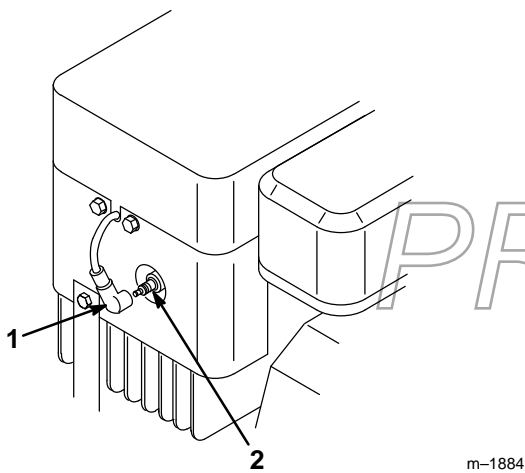

Figure 22

1. Spark plug wire
2. Spark plug

Checking the Spark Plug

1. Look at the center of the spark plug (Fig. 23). If you see light brown or gray on the insulator, the engine is operating properly. A black coating on the insulator usually means the air cleaner is dirty.

IMPORTANT: Never clean the spark plug. Always replace the spark plug when it has: a black coating, worn electrodes, an oily film, or cracks.

2. Check the gap between the center and side electrodes (Fig. 23). Bend the side electrode (Fig. 23) if the gap is not correct.

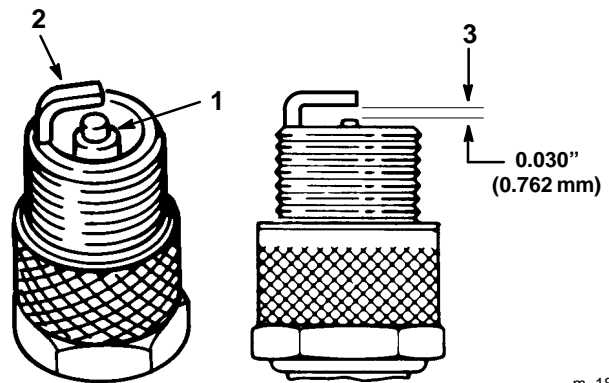

m-1870

Figure 23

1. Center electrode insulator
2. Side electrode
3. Air gap (not to scale)

Installing the Spark Plug

1. Install the spark plug and metal washer. Make sure the air gap is set correctly.
2. Tighten the spark plug to 15 ft-lb (20.4 Nm).
3. Push the wire onto the spark plug (Fig. 22).
4. Close the hood.

Fuel Tank

Draining The Fuel Tank

DANGER

POTENTIAL HAZARD

- In certain conditions gasoline is extremely flammable and highly explosive.

WHAT CAN HAPPEN

- A fire or explosion from gasoline can burn you, others, and cause property damage.

HOW TO AVOID THE HAZARD

- Drain gasoline from the fuel tank when the engine is cold. Do this outdoors in an open area. Wipe up any gasoline that spills.
- Never drain gasoline near an open flame or where gasoline fumes may be ignited by a spark.
- Never smoke a cigarette, cigar or pipe.

1. Park the machine so that the left front side is slightly lower than the right side to assure fuel tank drains completely. Then disengage the blade control (PTO), shift into neutral, set the parking brake, and turn the ignition key to "OFF" to stop the engine.
2. Open the hood.
3. Squeeze the ends of the hose clamp together and slide it up the fuel line toward the fuel tank (Fig. 24).
4. Pull the fuel line off the filter (Fig. 24) and allow gasoline to drain into a gas can or drain pan.

Note: Now is the best time to install a new fuel filter because the fuel tank is empty.

5. Install the fuel line onto the filter. Slide the hose clamp close to the filter to secure the fuel line and filter.

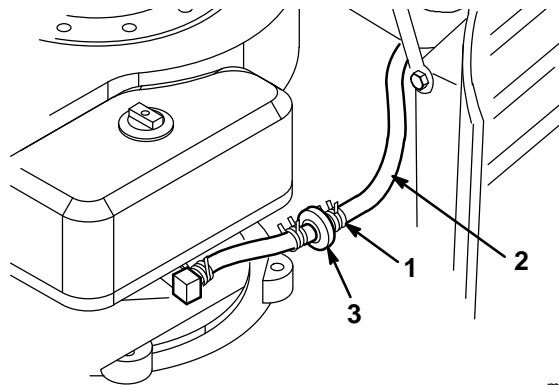

m-1873

Figure 24

1. Hose clamp
2. Fuel line
3. Filter

Fuel Filter

Service Interval/Specification

Replace the fuel filter after every 100 operating hours or yearly, whichever occurs first.

Replacing the Fuel Filter

The best time to replace the fuel filter (Fig. 24) is when the fuel tank is empty. Never install a dirty filter if it is removed from the fuel line.

1. Disengage the blade control (PTO), shift into neutral, set the parking brake, and turn the ignition key to "OFF" to stop the engine.
2. Open the hood.
3. Squeeze the ends of the hose clamps together and slide them away from the filter (Fig. 24).
4. Remove the filter from the fuel lines.
5. Install a new filter and move the hose clamps close to the filter.
6. Close the hood.

Air Cleaner

Service Interval/Specification

Foam Element: Clean and re-oil after every 25 operating hours.

Paper Element: Replace after every 100 operating hours or yearly, whichever occurs first.

Note: Service the air cleaner more frequently (every few hours) if operating conditions are extremely dusty or sandy.

Removing the Foam and Paper Elements

1. Disengage the blade control (PTO), shift into neutral, set the parking brake, and turn the ignition key to "OFF" to stop the engine.
2. Open the hood.
3. Clean around the air cleaner to prevent dirt from getting into the engine and causing damage. Unscrew the knob and remove the air cleaner cover (Fig. 25).

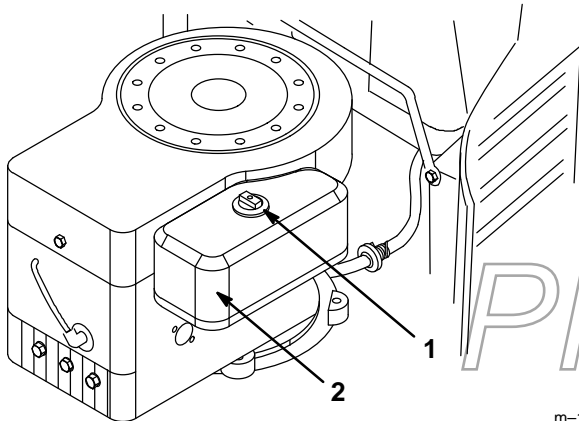

Figure 25

1. Knob
2. Air cleaner cover

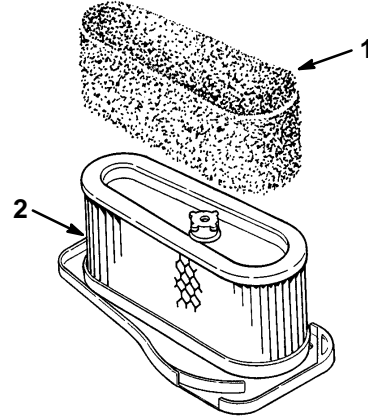

Figure 26

1. Foam element
2. Paper element

5. Unscrew the rubber nut and remove the paper element (Fig. 27).

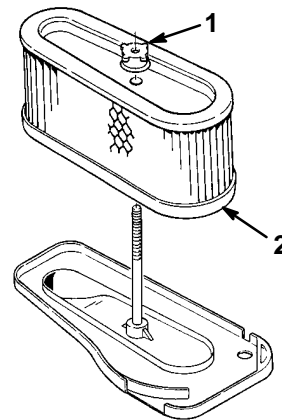

Figure 27

1. Rubber nut
2. Paper element

PROTOTYPE

Cleaning the Foam and Paper Elements

1. Foam Element

- A. Wash the foam element in liquid soap and warm water. When the element is clean, rinse it thoroughly.
- B. Dry the element by squeezing it in a clean cloth.
- C. Put one or two ounces of oil on the element (Fig. 28). Squeeze the element to distribute the oil.

IMPORTANT: Replace the foam element if it is torn or worn.

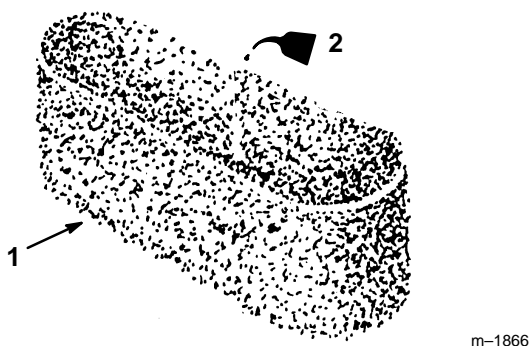

Figure 28

1. Foam element
2. Oil

2. Paper Element

- A. Lightly tap the element on a flat surface to remove dust and dirt (Fig. 29).
- B. Inspect the element for tears, an oily film, and damage to the rubber seal.

IMPORTANT: Never clean the paper element with pressurized air or liquids, such as solvent, gas, or kerosene. Replace the paper element if it is damaged or cannot be cleaned thoroughly.

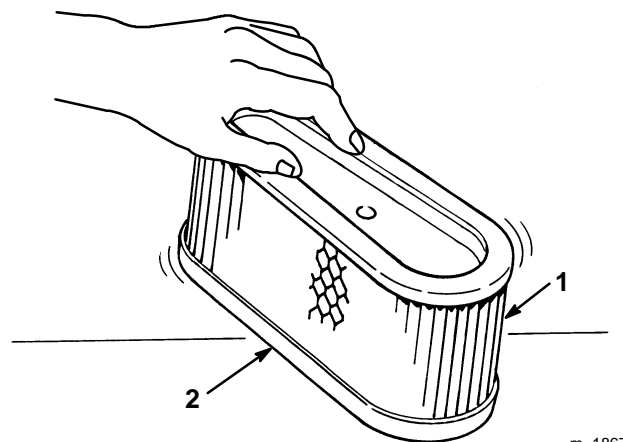

Figure 29

1. Paper element
2. Rubber seal

Installing the Foam and Paper Elements

IMPORTANT: To prevent engine damage, always operate the engine with the complete foam and paper air cleaner assembly installed.

1. Carefully slide the foam element onto the paper air cleaner element (Fig. 26).
2. Slide the air cleaner assembly onto the long rod. Now screw the rubber nut finger-tight against the air cleaner (Fig. 27).

Note: Make sure the rubber seal is flat against the air cleaner base.

3. Install the air cleaner cover and knob (Fig. 25). Tighten the knob snugly.
4. Close the hood.

Engine Oil

Service Interval/Specification

Change oil:

- After the first 5 operating hours.
- After every 50 operating hours.

Note: Change oil more frequently when operating conditions are extremely dusty or sandy.

Oil Type: Detergent oil (API service SF, SG or SH)

Crankcase Capacity: 48 oz/1-1/2 qt (1400 cc/1.4 l)

Viscosity: See table below

USE THESE SAE VISCOSITY OILS

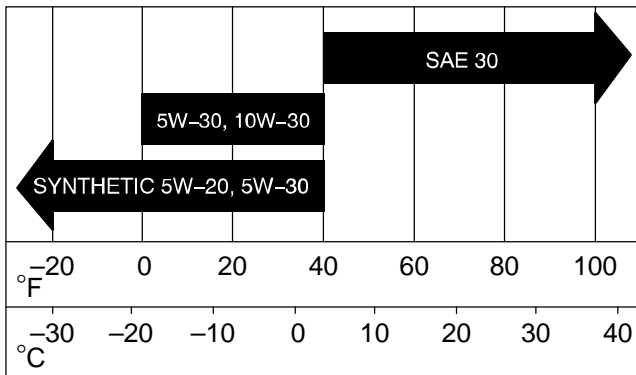

Checking Oil Level

1. Park the machine on a level surface, disengage the blade control (PTO), shift into neutral, set the parking brake, and turn the ignition key to "OFF" to stop the engine.
2. Open the hood.
3. Clean around the oil dipstick (Fig. 30) so dirt cannot fall into the filler hole and damage the engine.
4. Unscrew the oil dipstick and wipe the metal end clean (Fig. 30).

5. Screw the oil dipstick fully onto the filler tube (Fig. 30). Unscrew the dipstick again and look at the metal end. If oil level is low, slowly pour only enough oil into the filler tube to raise the level to the "FULL" mark.

IMPORTANT: Do not overfill the crankcase with oil because the engine may be damaged.

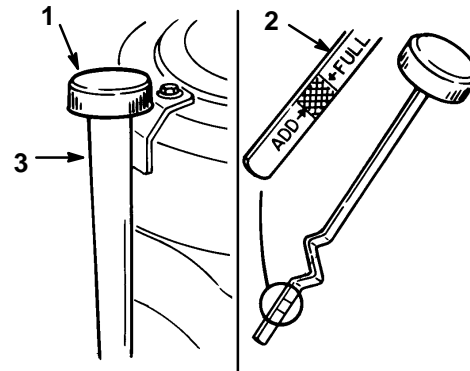

Figure 30

1. Oil dipstick
2. Metal end
3. Filler tube

m-1868

Changing/Draining Oil

1. Start the engine and let it run five minutes. This warms the oil so it drains better.
2. Park the machine so that the right front side is slightly lower than the left side to assure the oil drains completely. Then disengage the blade control (PTO), shift into neutral, set the parking brake, and turn the ignition key to "OFF" to stop the engine.
3. Open the hood.
4. Place a pan below the oil dipstick/fill tube and remove the drain plug (Fig. 31).
5. When oil has drained completely, install the drain plug.

Note: Dispose of the used oil at a certified recycling center.

- Slowly pour approximately 80% of the specified amount of oil into the filler tube (Fig. 30). Now check the oil level; refer to Checking Oil Level, page 30, steps 4–5.

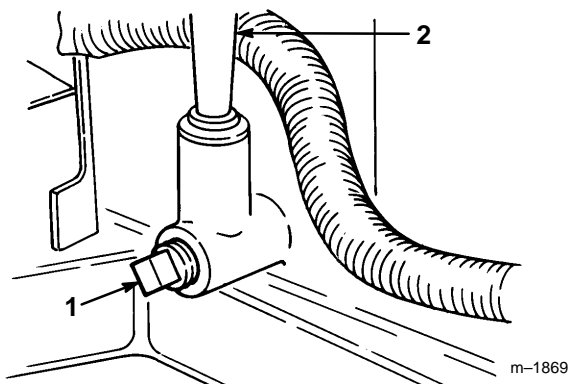

Figure 31

- Oil drain plug
- Oil dipstick/fill tube

Cutting Blade

To assure a superior quality of cut, keep the blade(s) sharp. For convenient sharpening and replacement, you may want to have an extra blade(s).

WARNING

POTENTIAL HAZARD

- A blade that is worn or damaged could break apart and pieces could be thrown at bystanders or at you as you use the mower.

WHAT CAN HAPPEN

- Pieces of blade that may be thrown could seriously injure or kill you or bystanders.

HOW TO AVOID THE HAZARD

- Periodically inspect the blade for wear and damage. Immediately install a new blade if it is worn or damaged.

Inspecting the Blade(s)

- Remove the mower; refer to Removing the Mower, page 33.
- Inspect the cutting edges (Fig. 32). If the edges are not sharp or have nicks, remove the blade(s) and sharpen them; refer to Sharpening the Blade(s), page 32.
- Inspect the blade(s), especially the curved area (Fig. 32). If you notice any damage, wear, or a slot forming in this area (Fig. 32), immediately install a new blade.

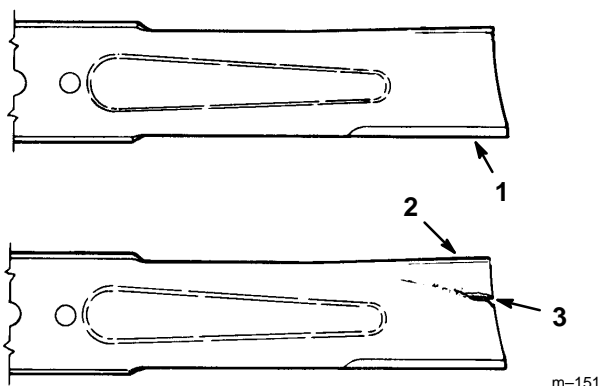
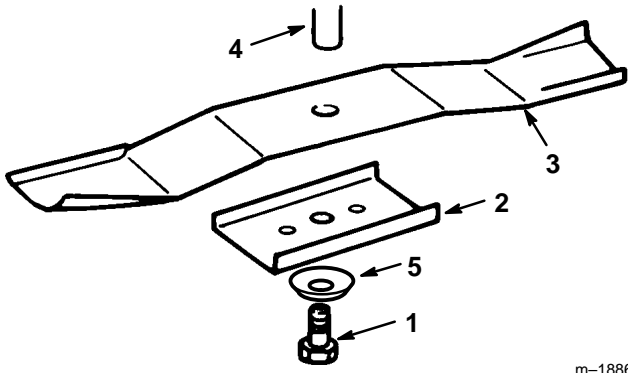

Figure 32

- Cutting edge
- Curved area
- Wear/slot forming

Removing the Blade

- Remove the mower; refer to Removing the Mower, page 33.
- Carefully tip the mower over.
- Remove the bolt (5/8" wrench), curved washer, retainer and blade (Fig. 33). A block of wood may be wedged between the blade and the mower to lock the blade when you are removing the bolt.
- Inspect all parts. If damage is noticed, install new parts.



m-1886

Figure 33

- | | |
|-------------|------------------|
| 1. Bolt | 4. Spindle |
| 2. Retainer | 5. Curved washer |
| 3. Blade | |

Sharpening the Blade(s)

1. Use a file to sharpen the cutting edge at both ends of the blade (Fig. 34). Maintain the original angle. The blade retains its balance if the same amount of material is removed from both cutting edges.

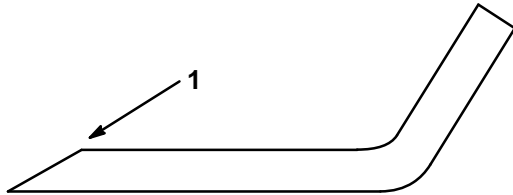

m-1854

Figure 34

1. Sharpen at original angle

2. Check the balance of the blade by putting it on a blade balancer (Fig. 35). If the blade stays in a horizontal position, the blade is balanced and can be used. If the blade is not balanced, file some metal off the back side of the blade. Repeat this procedure until the blade is balanced.

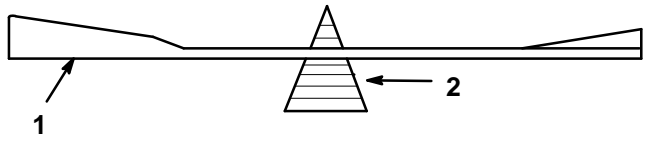

m-1855

Figure 35

- | | |
|----------|-------------|
| 1. Blade | 2. Balancer |
|----------|-------------|

Installing the Blade(s)

1. Install the blade, blade retainer, curved washer (cupped side toward blade), and the blade bolt (Fig. 33).

IMPORTANT: The curved part of the blade must be pointing toward the inside of the mower to assure proper cutting.

2. Tighten the blade bolt to 45–60 ft-lb (61–81 Nm).

Removing the Mower

1. Park the machine on a level surface, disengage the blade control (PTO), shift into neutral, set the parking brake, and turn the ignition key to "OFF" to stop the engine.
2. Remove the key from the ignition switch and pull the wire off the spark plug.
3. Move the height-of-cut lever (deck lift) into the "D" notch.
4. Remove the height-of-cut lift assist spring from the retaining bolt (Fig. 36), using the spring tool provided with the machine. The spring is between the frame and the right rear wheel.

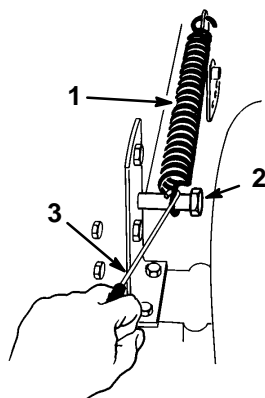

Figure 36

1. Spring
2. Bolt
3. Spring tool

m-1851

CAUTION

POTENTIAL HAZARD

- The height-of-cut lever (deck lift) is spring-tensioned.

WHAT CAN HAPPEN

- When the mower is being removed, this spring-loaded mechanism could suddenly release and injure you or someone else.

HOW TO AVOID THE HAZARD

- Move the height-of-cut lever (deck lift) to the "D" position and remove the height-of-cut lift assist spring to release the spring tension.

5. Move the height-of-cut lever (deck lift) into the "A" notch.

6. Remove the hair pin cotter and washer from the blade control arm on the left side of the mower (Fig. 37). Slide the rod off the arm.

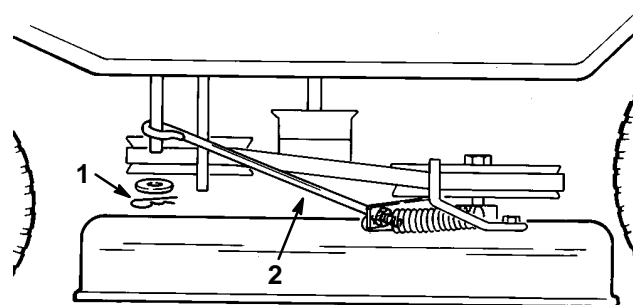

Figure 37

1. Hair pin cotter and washer
2. Rod

m-1897

7. Remove the bolts and lock nuts and pull the two mower pivot mount brackets down from the front axle (Fig. 38).

PROTOTYPE

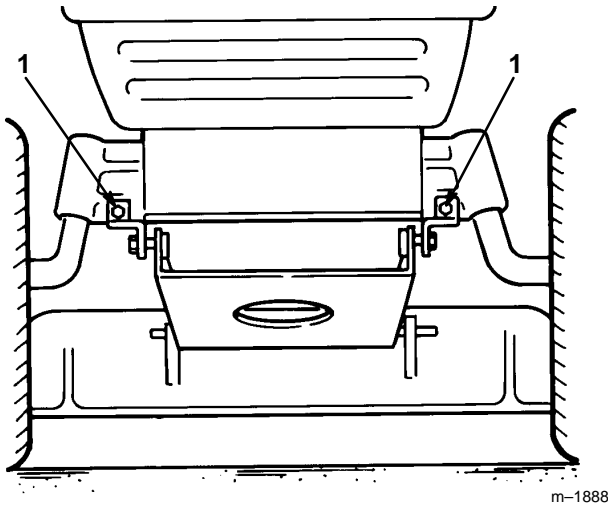

Figure 38

- 1. Pivot mount brackets

- 8. Remove the hair pin cotter and washer at the top of the mower leveling bracket (Fig. 39). Now slide the bracket off the mounting pin. Repeat this step on the opposite side of the mower.

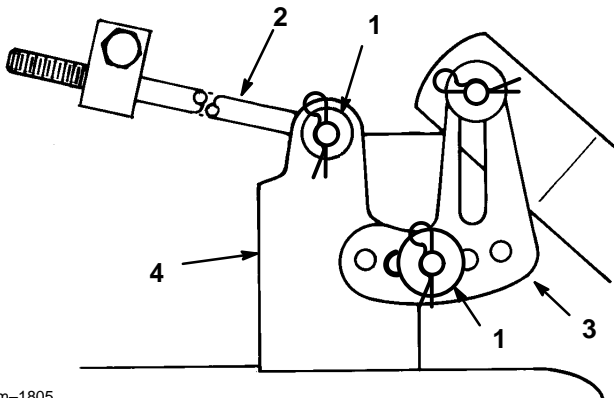

Figure 39

- 1. Hair pin cotter and washer
- 2. Long rod
- 3. Leveling bracket
- 4. Mower mount

- 9. Remove the hair pin cotter and washer from the end of the long rod (Fig. 39). Now slide the rod out of the mower mount. Repeat this step on the opposite side of the mower.

IMPORTANT: Tape or tie the long rods against the chassis to protect them from damage when you remove the mower.

- 10. Remove the mower belt from the lower engine pulley (Fig. 40). If you are careful, you can flex the belt guide(s) just far enough away from the pulley to remove the belt. If it is too difficult to remove the belt, loosen the bolts and nuts securing the belt guides.

IMPORTANT: Do not bend the belt guide(s) away from the pulley because the belt will not operate properly when the mower is installed later.

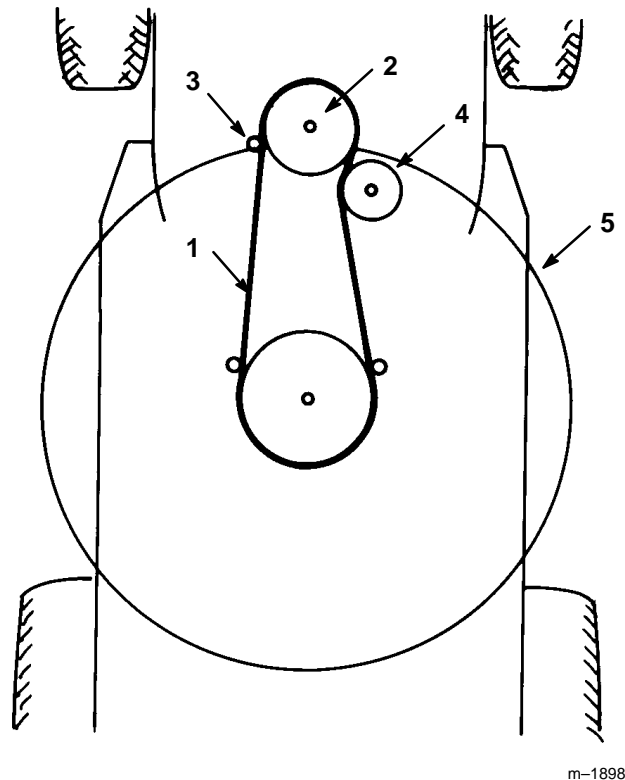

Figure 40

Top View

- 1. Mower belt
- 2. Engine pulley
- 3. Belt guide
- 4. Idler pulley
- 5. 32" mower

- 11. Turn the front wheels fully to the left. Slide the mower out to the right to complete removal.

Installing the Mower

1. Park the machine on a level surface, disengage the blade control (PTO), shift into neutral, set the parking brake, and turn the ignition key to "OFF" to stop the engine.
2. Remove the key from the ignition switch and pull the wire off the spark plug.
3. Turn the front wheels fully to the left. Slide the mower under the chassis from the right side.
4. Install mower belt onto the lower engine pulley (Fig. 40). If you are careful, you can flex the belt guide(s) just far enough away from the pulley to install the belt. If it is too difficult to install the belt, loosen the bolts and nuts securing the belt guides.

IMPORTANT: Do not bend the belt guide(s) away from the pulley. There must be a maximum 1/8" (3.175 mm) between the belt guide(s) and the edge of the pulley to keep the belt on the pulley during operation. If the space is more than 1/8" (3.175 mm), adjust the belt guide(s) and tighten them securely. The belt guide(s) must not contact the pulley.

5. Install the mower pivot mount brackets to the front axle with bolts and lock nuts (Fig. 41).

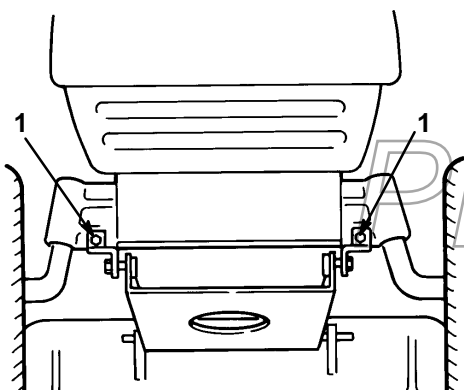

Figure 41

1. Pivot mount brackets

6. Move the height-of-cut lever (deck lift) into the "A" notch.

7. Slide the end of the long rod through the hole in the mower mount (Fig. 42). Install the washer and hair pin cotter to secure the rod in place. Repeat this step on the opposite side of the mower.
8. Mount the slotted mower leveling bracket onto the pin on the height-of-cut arm (Fig. 42). Install the washer and hair pin cotter to secure the mower. Repeat this step on the opposite side of the mower.

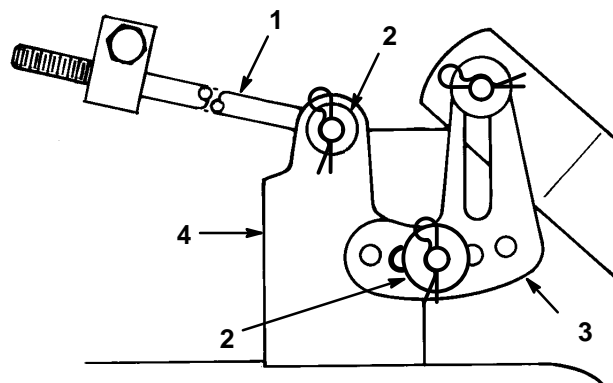

Figure 42

1. Rod
2. Hair pin cotter and washer
3. Leveling bracket
4. Mower mount

9. Install the blade control rod onto the blade control arm and secure it with the washer and hair pin cotter (Fig. 43).

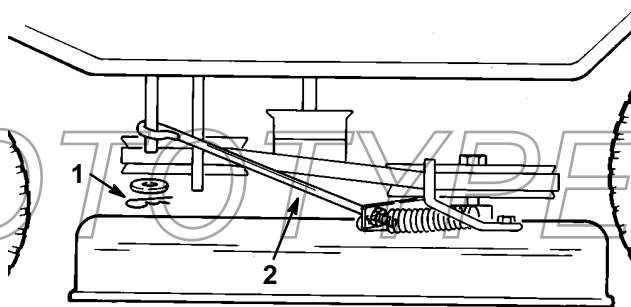
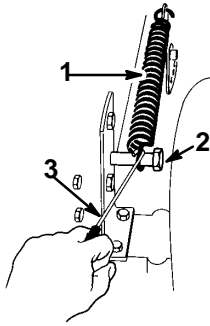

Figure 43

1. Hair pin cotter and washer
2. Rod

m-1897

10. Move the height-of-cut lever (deck lift) into the “D” notch to make it easier to install the height-of-cut lift assist spring.
11. Hook the height-of-cut lift assist spring onto the retaining bolt (Fig. 44), using the spring tool provided with the machine.



m-1851

Figure 44

1. Spring
2. Bolt
3. Spring tool

12. Check side-to-side blade level; refer to Side-to-Side Mower Leveling, page 37.

Blade Drive Belt

Removing the Blade Drive Belt

1. Remove the mower; refer to Removing the Mower, page 33.
2. Loosen the belt guide mounting bolts and move belt guides away from the pulley (Fig. 45).
3. Remove the belt from the pulley.

Installing the Blade Drive Belt

1. Install the new belt around the blade pulley and inside both belt guides (Fig. 45).
2. Adjust the belt guides so they are 1/8” (3 mm) away from the pulley and tighten mounting bolts (Fig. 45).

IMPORTANT: Make certain the left side belt guide is very tight so it does not move when the brake spring pulls against it.

3. Install the mower; refer to Installing the Mower, page 35.

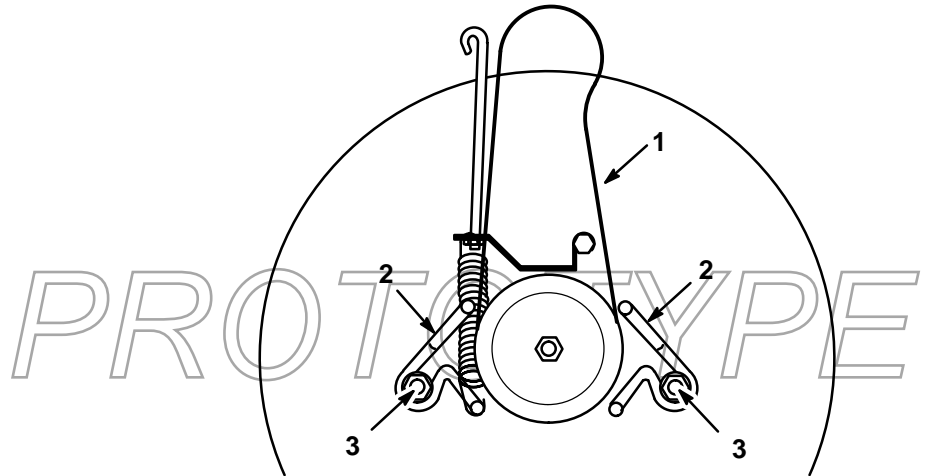

Figure 45

Top View

1. Mower belt
2. Belt guide
3. Mounting bolt

Side-to-Side Mower Leveling

The mower blades must be level from side to side. Check the side-to-side level any time you install the mower or when you see an uneven cut on your lawn. Before you level the mower, set the air pressure in the front and rear tires to the recommended inflation. Refer to "Tire Pressure" (page 21) in the Maintenance Section.

1. Park the machine on a level surface, disengage the blade control (PTO), shift into neutral, set the parking brake, and turn the ignition key to "OFF" to stop the engine.
2. Remove the key from the ignition switch and pull the wire off the spark plug.
3. Move the height-of-cut lever (deck lift) into the "C" notch.
4. Carefully rotate blade(s) side to side (Fig. 46). Measure between the outside cutting edges and the flat surface (Fig. 46). If both measurements are not within $3/16$ " (5 mm), an adjustment is required; refer to steps 5 and 6.

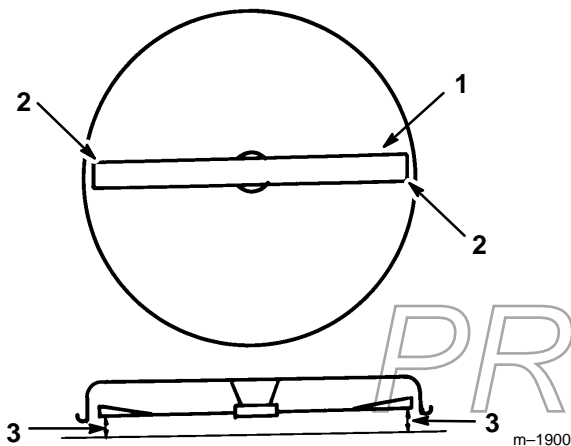

Figure 46

- | | |
|--------------------------|-----------------|
| 1. Blade side to side | 3. Measure here |
| 2. Outside cutting edges | |

5. Remove the hair pin cotter and washer from the leveling bracket (Fig. 47). To level the blade(s), reposition the leveling bracket in a different hole and install the washer and hair pin cotter.

(Fig. 47). A front hole lowers the blade height and a rear hole raises its height. Repeat this procedure on the opposite side.

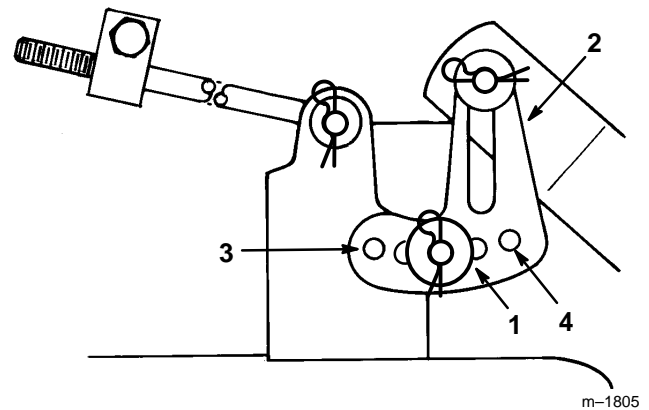

Figure 47

- | | |
|-------------------------------|---------------|
| 1. Hair pin cotter and washer | 3. Front hole |
| 2. Leveling bracket | 4. Rear hole |

6. Now check the front-to-rear blade slope; refer to Front-to-Rear Blade Slope, page 38.

Front-to-Rear Blade Slope

Check the front-to-rear blade slope any time you install the mower. Before you check the slope, set the air pressure in the front and rear tires to the recommended inflation. Refer to “Tire Pressure” (page 21) in the Maintenance Section. If the front of the mower is more than 5/8” (16 mm) lower than the rear of the mower, adjust the blade slope using the following instructions:

1. Park the machine on a level surface, disengage the blade control (PTO), shift into neutral, set the parking brake, and turn the ignition key to “OFF” to stop the engine.
2. Remove the key from the ignition switch and pull the wire off the spark plug.
3. Check and adjust side-to-side blade level if you have not checked the setting; refer to Side-to-Side Mower Leveling, page 37.
4. Move the height-of-cut lever (deck lift) into the “C” notch.
5. Check the front-to-rear blade slope by measuring between the bottom of the mower (front center and rear center) and the flat surface (Fig. 48). If the front of the mower is more than 5/8” (16 mm) lower than the rear of the mower, an adjustment is required; refer to steps 6–10.

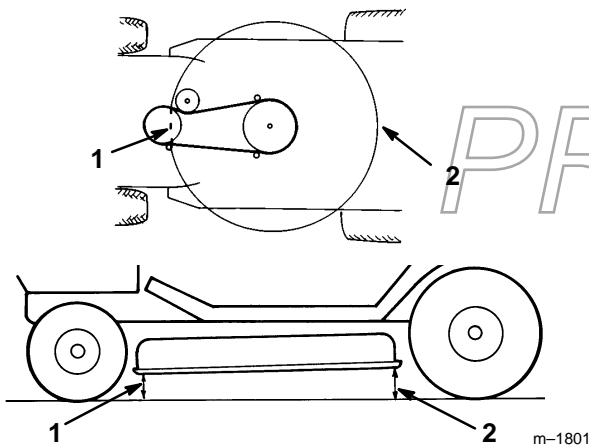

Figure 48

1. Measure front center
2. Measure rear center

6. Measure the length of the rod extending out the front of the adjusting block on the sides of the chassis (Fig. 49). If the rod length is not 5/8” (16 mm), remove the hair pin cotter and washer from the end of the rod (Fig. 49), and turn the rod until the 5/8” (16 mm) dimension is obtained. Then install the end of the rod into the hole in the mower mount and secure in place with washer and hair pin cotter. Repeat this procedure on the opposite side of the mower.

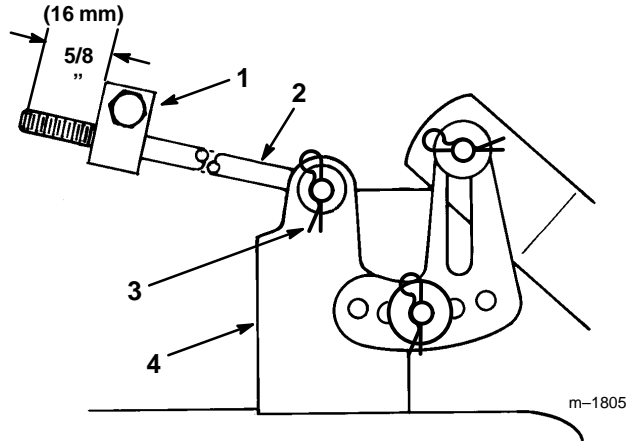

Figure 49

1. Adjusting block
2. Long rod
3. Hair pin cotter and washer
4. Mower mount

7. Check the front-to-rear slope again. If the front of the mower is more than 5/8” (16 mm) lower than the rear of the mower, proceed to step 8 for adjusting instructions. Otherwise, recheck the side-to-side level to assure it did not change.
8. Adjust the front-to-rear slope by rotating the special slope adjusting nuts on both sides of the mower pivot mount (Fig. 50).
9. Using a 1” wrench or socket slowly rotate the left side slope adjusting nut down to raise the front of the mower and up to lower it (Fig. 50). Rotate the slope adjusting nut until the front of the mower is 1/4” to 5/8” (6 mm to 16 mm) lower than the rear of the mower.
10. Now slowly rotate the right side slope adjusting nut until both adjusting nuts are in the same position.

IMPORTANT: If the slope adjustment does not stay in position after you adjust it, tighten the center bolt and lock nut and repeat step 9.

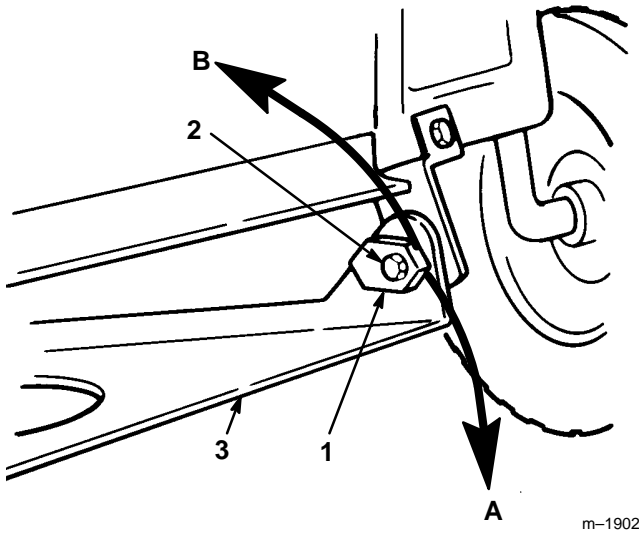

Figure 50

- | | |
|-------------------------------|----------------------|
| 1. Slope adjusting nut (left) | 2. Bolt and lock nut |
| A = Down to raise mower | 3. Mower pivot mount |
| B = Up to lower mower | |

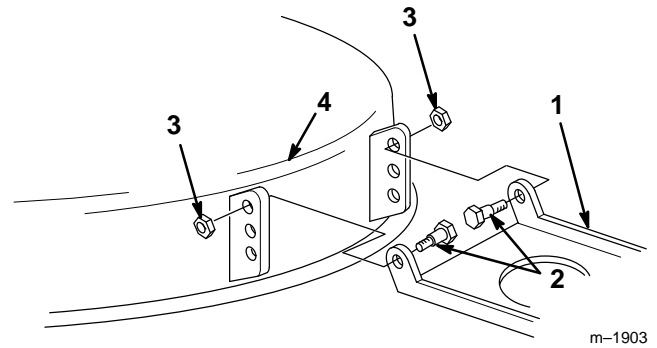

Figure 51

- | | |
|------------------|-------------|
| 1. Mower pivot | 3. Lock nut |
| 2. Shoulder bolt | 4. Mower |

11. If the 1/4" to 5/8" (6 mm to 16 mm) front slope cannot be achieved by rotating the slope adjusting nut, move the mower pivot mount at the mower (Fig. 51).
12. Remove the shoulder bolts and lock nuts from the mower (Fig. 51).
13. Lower the mower pivot one hole and install the shoulder bolts and lock nuts (Fig. 51).

Note: If your mower has only one hole, see an Authorized Service Dealer.
14. Repeat front-to-rear blade slope adjustment; refer to steps 8–10.

15. Recheck the front-to-rear slope again; refer to step 5.
16. When front-to-rear slope is correct, recheck the side-to-side level of the mower; refer to Side-to-Side Mower Leveling, page 37.
17. Push the wire onto the spark plug.

PROTOTYPE

Washing Underside of Mower

After each use wash the underside of the mower to prevent grass build-up for improved mulch action and clipping dispersal.

1. Park the machine on a hard level surface, disengage the power take off (PTO) and turn the ignition key to “OFF” to stop the engine.
2. Attach hose coupling to the end of the mower washout fitting, turn water on high (Fig. 52).
3. Lower the mower to the lowest height-of-cut.
4. Sit on the seat and start the engine. Engage power take off (PTO) and let mower run for one to three minutes.
5. Disengage the blade, power take off (PTO) and turn the ignition key to “OFF” to stop the engine. Wait for all moving parts to stop.
6. Turn the water off, remove hose coupling from the washout fitting.

Note: If the mower is not clean after one washing, soak and let stand for 30 minutes. Then repeat process again.

7. Run mower again for one to three minutes to remove excess water.

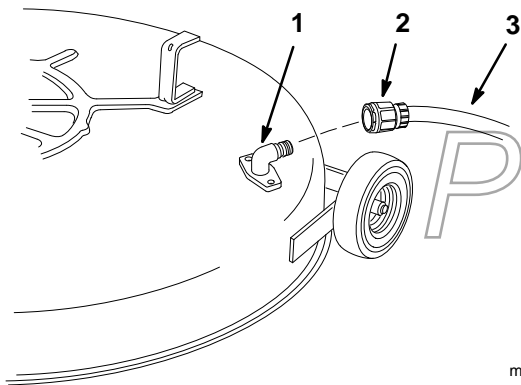

m-3118

Figure 52

1. Washout fitting
2. Coupling
3. Hose

WARNING

POTENTIAL HAZARD

- A broken or missing washout fitting could expose you and others to thrown objects or blade contact.

WHAT CAN HAPPEN

- Contact with thrown debris or blade contact will cause injury or death.

HOW TO AVOID THE HAZARD

- Replace broken or missing washout fitting immediately, before using mower again.
- Plug any hole(s) in mower with bolts and locknuts.
- Never put your hands or feet under the mower or through openings in the mower.

Cleaning and Storage

1. Disengage the power take off (PTO), set the parking brake, and turn the ignition key to “OFF” to stop the engine. Remove the key.
2. Remove grass clippings, dirt, and grime from the external parts of the entire machine, especially the engine. Clean dirt and chaff from the outside of the engine’s cylinder head fins and blower housing.

IMPORTANT: You can wash the machine with mild detergent and water. DO NOT PRESSURE WASH THE MACHINE.

Pressure washing may damage the electrical system or wash away necessary grease at friction points. Avoid excessive use of water, especially near the control panel, lights, engine, and the battery.

3. Check the brake; refer to Brake, page 21.
4. Service the air cleaner; refer to Air Cleaner, page 28.
5. Grease the chassis; refer to Greasing and Lubrication, page 20.
6. Change the crankcase oil; refer to Engine Oil, page 30.
7. Remove the spark plug(s) and check its condition; refer to Spark Plug, page 26. With the spark plug(s) removed from the engine, pour two tablespoons of engine oil into the spark plug hole. Now use the electric starter to crank the engine and distribute the oil inside the cylinder. Install the spark plug(s); refer to Spark Plug, page 26. Do not install the wire on the spark plug(s).
8. Remove the battery from the chassis, check the electrolyte level, and charge it fully; refer to Battery, page 24. Do not connect the battery cables to the battery posts during storage.

IMPORTANT: The battery must be fully charged to prevent it from freezing and being damaged at temperatures below 32°F (0°C). A fully charged battery maintains its charge for about 50 days at temperatures lower than 40°F (4°C). If the temperatures will be above 40°F (4°C), check the water level in the battery and charge it every 30 days.

9. Check the tire pressure; refer to Tire Pressure, page 21.
10. Prepare the machine for storage when non-use occurs over 30 days. Prepare machine for storage as follows.
 - A. Add a petroleum based stabilizer/conditioner to fuel in the tank. Follow mixing instructions from stabilizer manufacture. (1 oz. per gallon). **Do not use an alcohol based stabilizer (ethanol or methanol).**

Note: A fuel stabilizer/conditioner is most effective when mixed with fresh gasoline and used at all times.

 - B. Run engine to distribute conditioned fuel through the fuel system (5 minutes).
 - C. Stop engine, allow to cool and drain the fuel tank; refer to Fuel Tank, page 27.
 - D. Restart engine and run it until it stops.
 - E. Choke or prime the engine. Start and run engine until it will not start. Operate primer, if equipped on machine, several times to ensure fuel remains in primer system.
 - F. Dispose of fuel properly. Recycle as per local codes.

IMPORTANT: Do not store stabilizer/conditioned gasoline over 90 days.

11. Check and tighten all bolts, nuts, and screws. Repair or replace any part that is damaged or defective.

- 12.** Paint all scratched or bare metal surfaces. Paint is available from your Authorized Service Dealer.
- 13.** Store the machine in a clean, dry garage or storage area. Remove the key from the ignition switch and keep it in a memorable place. Cover the machine to protect it and keep it clean.

PROTOTYPE

Troubleshooting

PROBLEM	POSSIBLE CAUSES	CORRECTIVE ACTION
Starter does not crank	<ol style="list-style-type: none"> 1. Blade control (PTO) is ENGAGED. 2. Parking brake is not on. 3. Battery is dead. 4. Electrical connections are corroded or loose. 5. Fuse is blown. 6. Relay or switch is defective. 	<ol style="list-style-type: none"> 1. Move blade control (PTO) to DISENGAGED. 2. Set parking brake. 3. Charge the battery. 4. Check electrical connections for good contact. 5. Replace fuse. 6. Contact Authorized Service Dealer.
Engine will not start, starts hard, or fails to keep running.	<ol style="list-style-type: none"> 1. Operator is not seated. 2. Fuel tank is empty. 3. Air cleaner is dirty. 4. Spark plug wire is loose or disconnected. 5. Spark plug is pitted, fouled, or gap is incorrect. 6. Choke is not closing. 7. Dirt in fuel filter. 8. Idle speed is too low or mixture is incorrect. 9. Dirt, water, or stale fuel is in fuel system. 	<ol style="list-style-type: none"> 1. Sit on the seat. 2. Fill fuel tank with gasoline. 3. Clean or replace air cleaner element. 4. Install wire on spark plug. 5. Install new, correctly gapped spark plug. 6. Adjust throttle cable. 7. Replace fuel filter. 8. Adjust carburetor idle speed and idle mixture. 9. Contact Authorized Service Dealer.
Engine loses power.	<ol style="list-style-type: none"> 1. Engine load is excessive. 2. Air cleaner is dirty. 3. Oil level in crankcase is low. 4. Cooling fins and air passages under engine blower housing are plugged. 5. Spark plug is pitted, fouled, or gap is incorrect. 	<ol style="list-style-type: none"> 1. Shift into lower gear to reduce ground speed. 2. Clean air cleaner element. 3. Add oil to crankcase. 4. Remove obstruction from cooling fins and air passages. 5. Install new, correctly gapped spark plug.

PROBLEM	POSSIBLE CAUSES	CORRECTIVE ACTION
Engine loses power (continued).	<ol style="list-style-type: none"> 6. Vent hole in fuel cap is plugged. 7. Dirt in fuel filter. 8. Dirt, water, or stale fuel is in fuel system. 	<ol style="list-style-type: none"> 6. Clean or replace the fuel cap. 7. Replace fuel filter. 8. Contact Authorized Service Dealer.
Engine over heats.	<ol style="list-style-type: none"> 1. Engine load is excessive. 2. Oil level in crankcase is low. 3. Cooling fins and air passages under engine blower housing are plugged. 	<ol style="list-style-type: none"> 1. Shift into lower gear to reduce ground speed. 2. Add oil to crankcase. 3. Remove obstruction from cooling fins and air passages.
Abnormal vibration.	<ol style="list-style-type: none"> 1. Cutting blade(s) is bent or unbalanced. 2. Blade mounting bolt is loose. 3. Engine mounting bolts are loose. 4. Loose engine pulley, idler pulley, or blade pulley. 5. Engine pulley is damaged. 	<ol style="list-style-type: none"> 1. Install new cutting blade(s). 2. Tighten blade mounting bolt. 3. Tighten engine mounting bolts. 4. Tighten the appropriate pulley. 5. Contact Authorized Service Dealer.
Blade(s) does not rotate.	<ol style="list-style-type: none"> 1. Blade drive belt is worn, loose or broken. 2. Blade drive belt is off pulley. 	<ol style="list-style-type: none"> 1. Install new blade drive belt. 2. Install blade drive belt and check idler pulley and belt guides for correct position.
Machine does not drive.	<ol style="list-style-type: none"> 1. Traction belt is worn, loose or broken. 2. Traction belt is off pulley. 3. Transmission does not shift. 	<ol style="list-style-type: none"> 1. Contact Authorized Service Dealer. 2. Contact Authorized Service Dealer. 3. Contact Authorized Service Dealer.
Uneven cutting height.	<ol style="list-style-type: none"> 1. Tire pressure is incorrect. 2. Mower is not level. 3. Underside of mower is dirty. 	<ol style="list-style-type: none"> 1. Set tire pressure. 2. Level mower from side-to-side and front-to-rear. 3. Clean the underside of the mower.

PROTOTYPE



Consumer Riding Products

THE TORO TOTAL COVERAGE GUARANTEE

A Full Two-Year Warranty

(Limited Warranty For Commercial Use)

What Is Covered By This Express Warranty?

The Toro Company promises to repair any TORO Product used for normal residential purposes* if defective in materials or workmanship for a period of two years from the date of purchase with the following exceptions:

- Batteries are warranted for one year

This warranty covers the cost of parts and labor as well as transportation within a 15 mile radius of the servicing dealer.

What Products Are Covered By This Warranty?

This warranty applies to all consumer riding products and their attachments.

How About Commercial Use?

TORO Consumer Products and attachments used for commercial, institutional or rental use are covered by a limited warranty for the following time periods from the date of purchase:

Products	Warranty Period
• 300 and 5xi Series Tractors	
Chassis	1 year limited warranty
Liquid Cooled Gas Engines . . .	1 year limited warranty
Air Cooled Gas and Diesel Engines	2 year limited warranty
• All Others	90 day limited warranty

How Do You Get Warranty Service?

Should you feel your TORO Product contains a defect in material or workmanship, contact the dealer who sold you the product or any Authorized TORO Service Dealer or TORO Master Service Dealer. The Yellow Pages of your telephone directory is a good reference source. The dealer will either arrange service at his/her dealership or recommend another Authorized Service Dealer who may be more convenient. You may need proof of purchase (copy of registration card, sales receipt, etc.) for warranty validation.

If for any reason you are dissatisfied with the Service Dealer's analysis of the defect in materials or workmanship or if you need a referral to a TORO Service Dealer, please feel free to contact us at the following address:

Toro Customer Service Department
8111 Lyndale Avenue South
Bloomington, MN 55420-1196
612-888-8801
800-348-2424

What Must You Do To Keep The Warranty In Effect?

You must maintain your TORO Product by following the maintenance procedures described in the operator's manual. Such routine maintenance, whether performed by a dealer or by you, is at your expense.

What Does This Warranty Not Cover? and

How Does Your State Law Relate To This Warranty?

There is no other express warranty except for special emission system coverage on some products. This express warranty does not cover:

- Cost of regular maintenance service or parts, such as filters, fuel, lubricants, tune-up parts, blade sharpening, brake and clutch adjustments.
- Any product or part which has been altered or misused or required replacement or repair due to normal wear, accidents, or lack of proper maintenance.
- Repairs necessary due to improper fuel, contaminants in the fuel system, or failure to properly prepare the fuel system prior to any period of non-use over three months.
- Pickup and delivery charges for distances beyond a 15 mile radius from an Authorized TORO Service Dealer.

All repairs covered by this warranty must be performed by an Authorized TORO Service Dealer using Toro approved replacement parts.

Repair by an Authorized TORO Service Dealer is your sole remedy under this warranty.

The Toro Company is not liable for indirect, incidental or consequential damages in connection with the use of the TORO Products covered by this warranty, including any cost or expense of providing substitute equipment or service during reasonable periods of malfunction or non-use pending completion of repairs under this warranty. Some states do not allow exclusions of incidental or consequential damages, so the above exclusion may not apply to you.

This warranty gives you specific legal rights, and you may also have other rights which vary from state to state.

* Normal residential purposes means mowing the lawn on the same lot as your home. Use at more than one location is considered commercial use and the commercial use warranty would apply.

COUNTRIES OTHER THAN THE UNITED STATES OR CANADA

Customers who have purchased TORO Products exported from the United States or Canada should contact their TORO Distributor (Dealer) to obtain guarantee policies for your country, province, or state. If for any reason you are dissatisfied with your Distributor's service or have difficulty obtaining guarantee information, contact the TORO importer. If all other remedies fail, you may contact us at The Toro Company.