



ProLine Mid-Size
12.5 HP Traction Unit
30165—200000001 & Up

Operator's Manual

Introduction

Thank you for purchasing a Toro product.

All of us at Toro want you to be completely satisfied with your new product, so feel free to contact your local Authorized Service Dealer for help with service, genuine replacement parts, or other information you may require.

Whenever you contact your Authorized Service Dealer or the factory, always know the model and serial numbers of your product. These numbers will help the Service Dealer or Service Representative provide exact information about your specific product. You will find the model and serial number plate located in a unique place on the product as shown below.

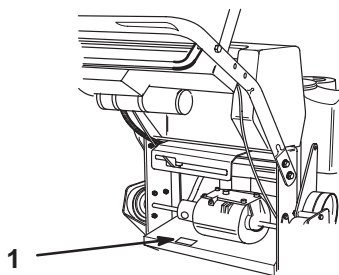

m-4189

1. Model and Serial Number Plate

For your convenience, write the product model and serial numbers in the space below.

Model No: _____
Serial No. _____

Read this manual carefully to learn how to operate and maintain your product correctly. Reading this manual will help you and others avoid personal injury and damage to the product. Although we design, produce and market safe, state-of-the-art products, you are responsible for using the product properly and safely. You are also responsible for training persons, who you allow to use the product, about safe operation.

The warning system in this manual identifies potential hazards and has special safety messages that help you and others avoid personal injury, even death. DANGER, WARNING and CAUTION are signal words used to identify the level of hazard. However, regardless of the hazard, be extremely careful.

DANGER signals an extreme hazard that will cause serious injury or death if the recommended precautions are not followed.

WARNING signals a hazard that may cause serious injury or death if the recommended precautions are not followed.

CAUTION signals a hazard that may cause minor or moderate injury if the recommended precautions are not followed.

Two other words are also used to highlight information. “Important” calls attention to special mechanical information and “Note” emphasizes general information worthy of special attention.

The left and right side of the machine is determined from the normal operator’s position.

!	WARNING:	!
The engine exhaust from this product contains chemicals known to the State of California to cause cancer, birth defects, or other reproductive harm.		

IMPORTANT: This engine is not equipped with a spark arrester muffler. It is a violation of California Public Resource Code Section 4442 to use or operate this engine on any forest-covered, brush-covered or grass-covered land. Other states or federal areas may have similar laws.

Contents

	Page		Page
Safety	2	Maintenance	21
Slope Chart	4	Service Interval Chart	21
Symbols Glossary	5	Air Cleaner	22
Symbols Glossary	6	Engine Oil	23
Symbols Glossary	7	Spark Plug	25
Gasoline and Oil	8	Greasing and Lubrication	26
Recommended Gasoline	8	Tire Pressure	26
Stabilizer/Conditioner	9	Brake	27
Filling the Fuel Tank	9	Fuel Tank	28
Check Engine Oil Level	9	Fuel Filter	29
Set-up	10	Replacing the Drive Belt	29
Loose Parts	10	Cleaning the Cooling System	29
Mount Control Panel and Fuel Tank	11	Replacing the Traction Belt	30
Install Shift Lever	11	Adjusting the Electric Clutch	30
Install Upper Handle	12	Wiring Diagram	31
Connect Throttle Cable	12	Cleaning and Storage	32
Connect Wire Harness	13	Troubleshooting	33
Install Control Rods	13		
Operation	15		
Think Safety First	15		
Controls	15		
Parking Brake	16		
Starting and Stopping the Engine	17		
Operating Mower Blade Control (PTO) ..	18		
The Safety Interlock System	18		
Driving Forward or Backward	19		
Lower Control Bar Operation	20		
Stopping the Machine	20		

Safety

Toro designed this lawn mower for cutting and mulching grass, or, when equipped with a grass bag, for catching cut grass. Any use for purposes other than these could prove dangerous to the operator or to bystanders.

Note: This engine is **not** equipped with a spark arrester muffler. Operating this mower on any forest-covered, brush-covered, or unimproved grass-covered land without an approved spark arrester muffler may violate your state law.

WARNING

POTENTIAL HAZARD

- **Engine exhaust contains carbon monoxide, which is an odorless, deadly poison.**

WHAT CAN HAPPEN

- **Carbon monoxide can kill you and is also known to the State of California to cause birth defects.**

HOW TO AVOID THE HAZARD

- **Do not run engine indoors or in an enclosed area.**

To ensure maximum safety, best performance, and to gain knowledge of the product, it is essential that you and any other operator of the lawn mower read and understand the contents of this manual before the motor is ever started. Pay particular attention to the safety alert symbol  which means CAUTION, WARNING, OR DANGER — “personal safety instruction.” Read and understand the instruction because it has to do with safety. Failure to comply with instruction may result in personal injury.

General Lawn Mower Safety

The following instructions have been adapted from the ANSI/OPEI standard B71.1—1998 and ISO standard 5395:1990(E). Information or terminology specific to Toro lawn mowers is enclosed in parenthesis.

This cutting machine is capable of amputating hands and feet and throwing objects. Failure to observe the following safety instructions could result in serious injury or death.

Training

- Read the instructions carefully. Be familiar with the controls and the proper use of the equipment before starting.
- See manufacturer’s instructions for proper operation and installation of accessories. Only use accessories approved by the manufacturer.
- Never allow children or people unfamiliar with these instructions to use the mower. Local regulations may restrict the age of the operator.
- Never mow while people, especially children, or pets are nearby. Stop mower if anyone enters the area.

Tragic accidents can occur if the operator is not alert to the presence of children. Children are often attracted to the mower and the mowing activity. **Never** assume that children will remain where you last saw them.

- Keep children out of the mowing area and under the watchful care of a responsible adult.
- Be alert and turn mower off if children enter the area.
- Use extra care when approaching blind corners, shrubs, trees, or other objects that may obscure vision.
- Keep in mind that the operator or user is responsible for accidents or hazards occurring to other people or their property.

Preparation

- While mowing, always wear substantial footwear and long trousers.
- Do not operate the equipment when barefoot or wearing open sandals.
- Always wear safety goggles or safety glasses with side shields when operating mower.
- Thoroughly inspect the area where the equipment is to be used and remove all stones, sticks, wires, bones, and other foreign objects.
- **Warning: Gasoline is highly flammable.** Take the following precautions:
 - Store fuel in containers specifically designed for this purpose.

- Refuel outdoors only and do not smoke while refuelling.
- Add fuel before starting the engine. Never remove the cap of the fuel tank or add gasoline while the engine is running or when the engine is hot.
- If gasoline is spilled, do not attempt to start the engine but move the machine away from the area of spillage and avoid creating any source of ignition until gasoline vapors have dissipated.
- Replace all fuel tank and container caps securely.
- If the fuel tank has to be drained, do this outdoors.
- Replace faulty mufflers.
- Before using, always visually inspect to see that the blades, blade bolts, and cutter assembly are not worn or damaged. Replace worn or damaged blades and bolts in sets to preserve balance.
- On multibladed machines, take care as rotating one blade can cause other blades to rotate.

Operation

- Do not operate the engine in a confined space where dangerous carbon monoxide fumes can collect.
- Mow only in daylight or in good artificial light.
- Always be sure of your footing on slopes.
- Walk; never run.
- Keep a firm hold on the handle.
- For wheeled rotary machines, mow across the face of slopes, never up and down.
- Exercise extreme caution when changing direction on slopes.
- Do not mow excessively steep slopes.
- Use extreme caution when reversing or pulling the mower towards you.
- Before and while moving backwards, look behind and down for small children.
- Stop the blade(s) if the mower has to be tilted for transportation when crossing surfaces other than grass and when transporting the mower to and from the area to be mowed.
- Never operate the mower with damaged or missing guards or shields, or without safety devices; for example, deflectors and/or grass catchers in place.
- Do not change the engine governor settings or overspeed the engine.
- Disengage all blade and drive clutches before starting the engine.
- Start the engine or switch on the motor carefully according to instructions and with feet well away from the blade(s).
- Do not tilt when starting the engine or switching on the motor, unless the mower has to be tilted for starting. In this case, do not tilt it more than absolutely necessary and lift only the part which is away from the operator.
- Do not start the engine when standing in front of the discharge chute.
- Do not put hands or feet near or under rotating parts. Keep clear of the discharge opening at all times.
- Never pick up or carry a mower while the engine is running.
- Stop the engine and disconnect the spark plug lead
 - before clearing blockages or unclogging chute;
 - before checking, cleaning, or working on the mower;
 - after striking a foreign object. Inspect the mower for damage and make repairs before restarting and operating the mower;
 - if mower starts to vibrate abnormally (check immediately).
- Stop the engine
 - whenever you leave the mower;
 - before refuelling.

- Reduce the throttle setting during engine run-out and, if the engine is provided with a shut-off valve, turn the fuel off at the conclusion of mowing.
- Stop the blade(s) when crossing gravel drives, walks, or roads.
- Shut the engine (motor) off and wait until the blade comes to complete stop before removing grass catcher.
- Do not operate the mower while under the influence of alcohol or drugs.
- If the equipment should start to vibrate abnormally, stop the engine (motor) and check immediately for the cause. Vibration is generally a warning of trouble.

Slopes are a major factor related to slip and fall accidents which can result in a severe injury. If you feel uneasy on a slope, do not mow it.

- Watch for holes, ruts, or bumps. Tall grass can hide obstacles.
- **Do not** mow near drop-offs, ditches, or embankments. The operator could lose footing or balance.
- **Do not** mow on wet grass. Reduced footing could cause slipping.

Maintenance and Storage

- Keep all nuts, bolts (especially blade attachment bolts), and screws tight to be sure the equipment is in safe working condition.
- Never store the equipment with gasoline in the tank inside a building where fumes may reach an open flame or spark.
- Allow the engine to cool before storing in any enclosure.
- To reduce the fire hazard, keep the engine, muffler, battery compartment, and gasoline storage area free of grass, leaves, or excessive grease.
- Check the grass catcher frequently for wear or deterioration.
- Replace worn or damaged parts for safety.
- Use extra care when handling gasoline; vapors are explosive.

- tamper with safety devices. Check their proper operation regularly.
- Keep the mower free of grass, leaves, or other debris build-up. Clean up oil or fuel spillage.
- Stop and inspect the equipment if you strike an object. Repair, if necessary, before restarting.
- Never attempt to make wheel height adjustments while the engine (motor) is running.
- Always disconnect electric mowers (live operated) before cleaning, repairing, or adjusting.
- Grass catcher components are subject to wear, damage, and deterioration, which could expose moving parts or allow objects to be thrown. Frequently check components and replace with manufacturer's recommended parts when necessary.
- Mower blades are sharp and can cut. Wrap the blade(s) or wear gloves, and use extra caution when servicing them.
- Do not change the engine governor setting or overspeed the engine.
- To ensure the best performance and safety, purchase only genuine Toro replacement parts and accessories. **Do not use "will fit" parts and accessories; they may cause a safety hazard.**

Slope Chart

Read all safety instructions on pages 2-9.

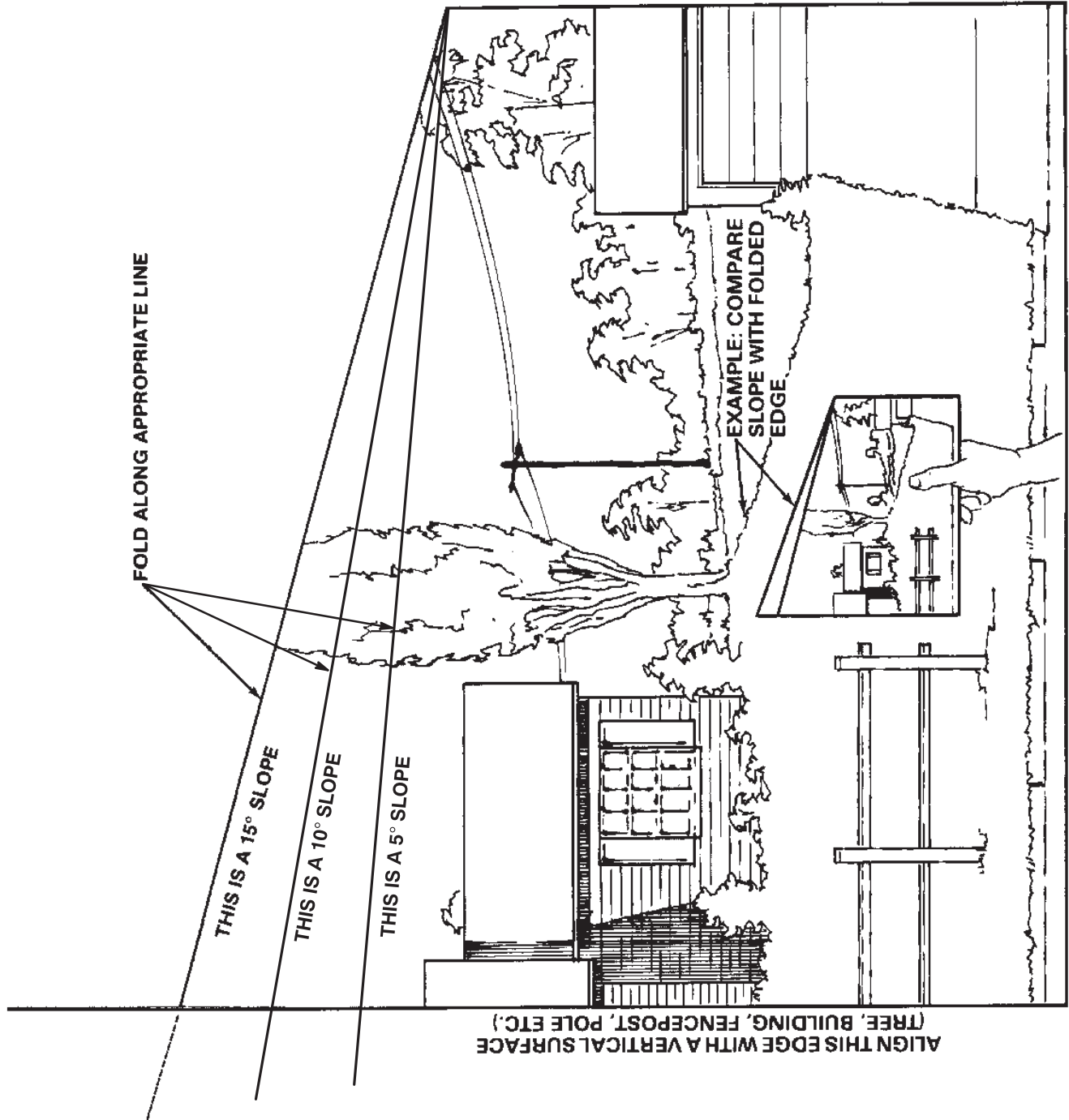

Symbols Glossary

Safety alert triangle—symbol within triangle indicates a hazard



Fire, open light & smoking prohibited



Safety alert symbol



Fire or open flame



Read operator's manual



Explosion



Consult technical manual for proper service procedures



Do not dispose of lead battery in garbage



Shut off engine & remove key before performing maintenance or repair work



Stay a safe distance from the machine

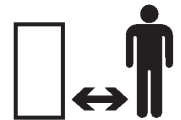

Caustic liquids, chemical burns to fingers or hand



Stay safe distance from machine

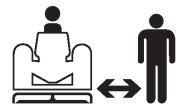

Caution, toxic risk



Stay safe distance from machine

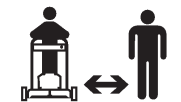

Eye protection must be worn



Stay safe distance from machine



First aid, flush with water



Keep children away from battery



Symbols Glossary

Do not open or remove safety shields while engine is running



Machine rollover, riding mower



Thrown or flying objects, whole body exposure



To operate machine on a slope, use with 16kg weight kit & operate with deck lowered



Thrown or flying objects, whole body exposure



Stop engine before leaving operator position



Keep guards and safety shields in place



Machine being transported

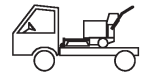

Severing of toes & fingers, rotary mower blade



Blade cutting element-height adjustment

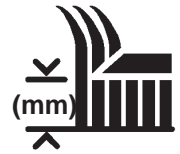

Severing of fingers or hand, mower blade



Blade engagement control operation



Severing of toes or foot, mower blade



Discharge door lever operation



Cutting of fingers or hand



Cutting of foot



Fuel shut off control operation









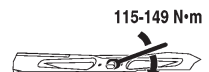









Hot surface, burns to fingers or hands



Blade retaining bolts must be Torqued to 115–149 N.m



Symbols Glossary

Fast		Power take off (PTO)	
Slow		Engage	
Decreasing/Increasing		Disengage	
On/Run		Traction drive	
Off/stop		Forward	F
Engine start		Reverse	R
Engine stop		Neutral	N
Choke		First gear	1
Brake system		Second gear	2
Parking brake		Third gear	3
Battery		Fourth gear	4
Fuel			

Gasoline and Oil

Recommended Gasoline

Use UNLEADED Regular Gasoline suitable for automotive use (85 pump octane minimum). Leaded regular gasoline may be used if unleaded regular is not available.

IMPORTANT: Never use methanol, gasoline containing methanol, or gasohol containing more than 10% ethanol because the fuel system could be damaged. Do not mix oil with gasoline.

DANGER

POTENTIAL HAZARD

- In certain conditions gasoline is extremely flammable and highly explosive.

WHAT CAN HAPPEN

- A fire or explosion from gasoline can burn you, others, and cause property damage.

HOW TO AVOID THE HAZARD

- Use a funnel and fill the fuel tank outdoors, in an open area, when the engine is cold. Wipe up any gasoline that spills.
- Do not fill the fuel tank completely full. Add gasoline to the fuel tank until the level is 1/4" to 1/2" (6 mm to 13 mm) below the bottom of the filler neck. This empty space in the tank allows gasoline to expand.
- Never smoke when handling gasoline, and stay away from an open flame or where gasoline fumes may be ignited by a spark.
- Store gasoline in an approved container and keep it out of the reach of children. Never buy more than a 30-day supply of gasoline.

DANGER

POTENTIAL HAZARD

- When fueling, under certain circumstances, a static charge can develop, igniting the gasoline.

WHAT CAN HAPPEN

- A fire or explosion from gasoline can burn you and others and cause property damage.

HOW TO AVOID THE HAZARD

- Always place gasoline containers on the ground away from your vehicle before filling.
- Do not fill gasoline containers inside a vehicle or on a truck or trailer bed because interior carpets or plastic truck bed liners may insulate the container and slow the loss of any static charge.
- When practical, remove gas-powered equipment from the truck or trailer and refuel the equipment with its wheels on the ground.
- If this is not possible, then refuel such equipment on a truck or trailer from a portable container, rather than from a gasoline dispenser nozzle.
- If a gasoline dispenser nozzle must be used, keep the nozzle in contact with the rim of the fuel tank or container opening at all times until fueling is complete.

 **WARNING**
POTENTIAL HAZARD

- Gasoline is harmful or fatal if swallowed. Long-term exposure to vapors has caused cancer to laboratory animals.

WHAT CAN HAPPEN

- Failure to use caution may result in serious injury or illness

HOW TO AVOID THE HAZARD

- Avoid prolonged breathing of vapors.
- Keep face away from nozzle and gas tank or conditioner opening.
- Keep gas away from eyes and skin.

Using Stabilizer/Conditioner

Use a fuel stabilizer/conditioner in the machine to provide the following benefits:

- Keeps gasoline fresh during storage of 90 days or less. For longer storage, drain the fuel tank.
- Cleans the engine while it runs
- Eliminates gum-like varnish buildup in the fuel system, which causes hard starting

IMPORTANT: Do not use fuel additives containing methanol or ethanol.

Add the correct amount of gas stabilizer/conditioner to the gas.

Note: A fuel stabilizer/conditioner is most effective when mixed with fresh gasoline. To minimize the chance of varnish deposits in the fuel system, use fuel stabilizer at all times.

Filling the Fuel Tank

1. Shut the engine off.
2. Clean around the fuel tank cap and remove the cap. Use a funnel and add unleaded regular gasoline to the fuel tank, until the level is 1/4 to 1/2 inch (6 mm to 13 mm) below the bottom of the filler neck. This space in the tank allows gasoline to expand. Do not fill the fuel tank completely full.
3. Install the fuel tank cap securely. Wipe up any gasoline that may have spilled.

Check Engine Oil Level

Before you start the engine and use the machine, check the oil level in the engine crankcase; refer to Checking Oil Level, page 26.

Set-up

Loose Parts

Note: Use the chart below to verify all parts have been shipped.

DESCRIPTION	QTY.	USE
Upper Handle	1	Install upper handle to frame
Flanged bolt 3/8–16 x 1" (26 mm)	4	
Flange nut 3/8–16	4	
Shift lever	1	Install shift lever to transmission
Shift lever mounting bracket	1	
Washer 1/4"	1	
Bolt 1/4–28 x 2" (51 mm)	1	
Rod fitting	2	Install control rods
Clevis pin	2	
Washer	2	
Hairpin cotter	2	
Fuel tank	1	Install fuel tank and control panel
Control panel	1	
Bolt 5/16–1/ x 7/8" (22.5 mm)	4	
Lock washer 5/16"	4	
Washer 5/16"	4	
Hose clamp	2	
Wire tie	1	Retain wire harness
Operator's Manual	1	Rear before operating machine
Parts catalog	1	
Registration card	1	Fill out and return to Toro

Mount Control Panel and Fuel Tank

1. Position control panel under bottom of rear frame (Fig. 1). Align fuel tank to top of rear frame (Fig. 1).

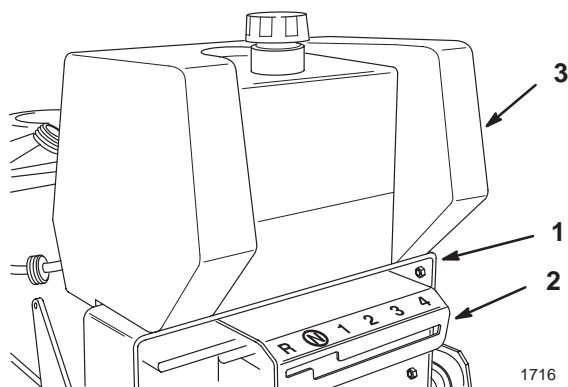

Figure 1

- | | |
|------------------|--------------|
| 1. Rear frame | 3. Fuel tank |
| 2. Control panel | |

2. Secure control panel and fuel tank to rear frame with (4) 7/8 in. (22.5 mm) bolts, lock washers and washers (Fig. 2).
3. Slide hose clamp onto fuel line (Fig. 2). Push fuel line onto fuel tank fitting and secure with hose clamp (Fig. 2).

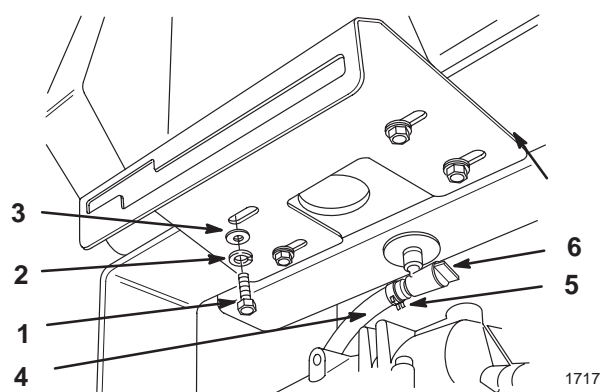

Figure 2

- | | |
|---------------------------------|-----------------|
| 1. Bolt 5/8-18 x 7/8" (22.5 mm) | 4. Fuel line |
| 2. Lock washer | 5. Hose clamp |
| 3. Washer | 6. Fuel fitting |

Install Shift Lever

1. Align mounting block with flats of shaft on top of transmission and slide onto shaft (Fig. 3).

Note: DO NOT remove rubber washer on transmission shaft.

2. Slide shift lever through control panel and align mounting hole in lever with mounting block on transmission. Secure lever to transmission with 51 mm bolt and washer. Torque bolt to 115 in. lb. (155 N.m).

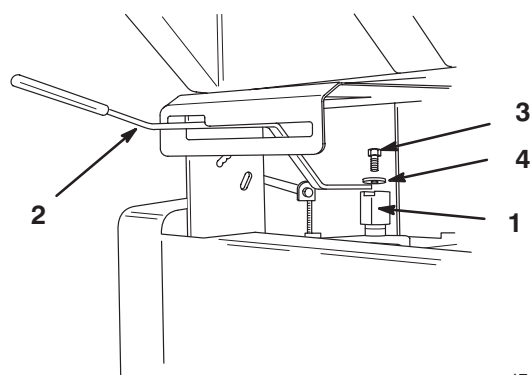

Figure 3

- | | |
|-------------------|-----------------------------|
| 1. Mounting block | 3. Bolt 1/4-28 x 2" (51 mm) |
| 2. Shift lever | 4. Washer |

3. Place transmission in neutral. Align control panel so there is .060 in. (2 mm) space between panel and lever.

Install Upper Handle

1. Align upper handle mounting holes with desired mounting holes in rear frame (upper or lower set of holes)
2. Secure each side with (2) 3/8 -16 x 1" (26mm) flange bolts and flange nuts (Fig. 4). Torque bolts to 25 ft. lbs. (34 N.m).
3. Route cables and wire harness inside of frame (Fig. 4)

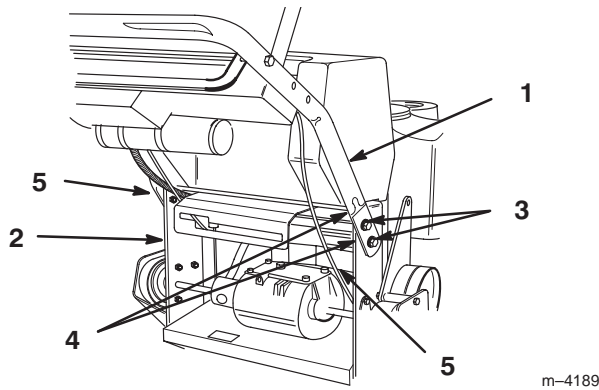

Figure 4

- | | |
|-----------------------------------|---------------------|
| 1. Upper handle | 4. Flange nut 3/8 |
| 2. Rear frame | 5. Wires and cables |
| 3. Flange bolt 3/8 x 16-1" (26mm) | |

Connect Throttle Cable

1. Place throttle control lever in FAST position.(Fig. 5).
2. Hook wire Z-bend into hole of speed control lever (Fig. 5).
3. Loosen cable clamp screw allowing cable installation, but do not tighten (Fig. 5).
4. Move control cable casing and wire until hole in speed control lever is aligned with hole in base plate. Insert a 1/4 in. (6.35 mm) diameter pin or bolt into aligned holes to hold adjustment.
5. Pull throttle cable slightly to remove any slack and tighten cable clamp screw to lock adjustment in place.
6. Remove alignment pin and check control operation.

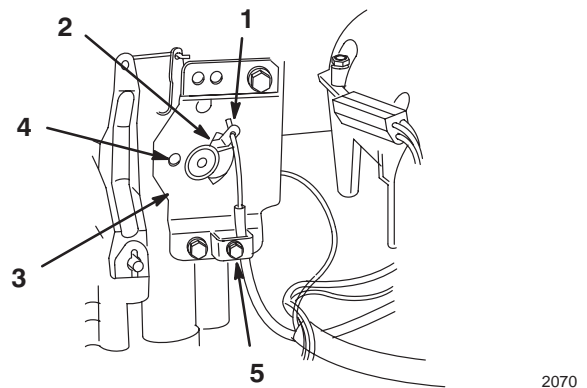

Figure 5

- | | |
|------------------------|-------------------------------------|
| 1. Wire Z-bend | 4. Alignment holes 1/4 in. (6.35mm) |
| 2. Speed control lever | 5. Cable clamp |
| 3. Base plate | |

Connect Wire Harness

1. Secure clutch and engine in-line wire connectors (Fig. 6).

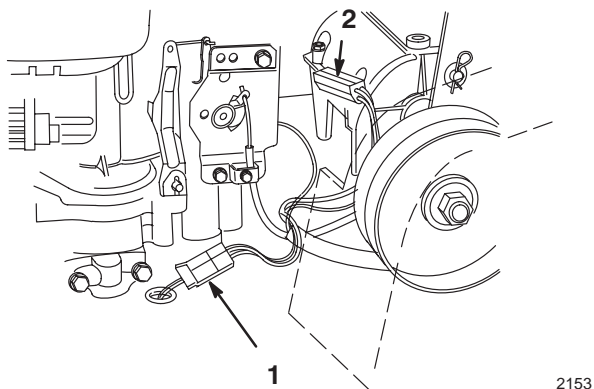

Figure 6

1. Clutch wire connector
2. Engine wire connector

2. Remove top jam nut from right rear engine mounting bolt located behind oil dipstick.
3. Mount remaining wire to engine bolt and secure with jam nut.

Install Control Rods

1. Thread a rod fitting onto each control rod approximately 2 in. (51 mm) (Fig. 7) or until upper control bar (Fig. 8) is approximately perpendicular to the ground.
2. Mount rod fitting ends to mounting holes in idler brackets (from outside) with clevis pins, washers and hairpin cotters (Fig. 7).

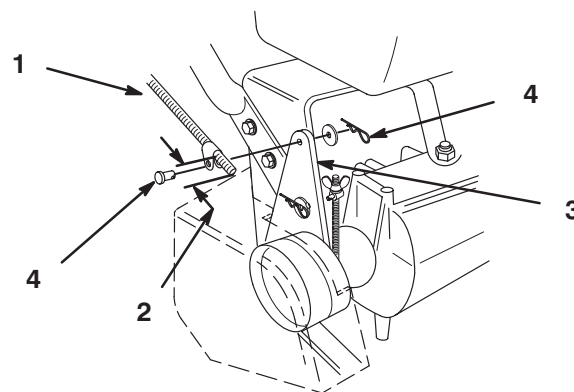

Figure 7

1. Control rod and fitting
2. 2 in. (51 mm)
3. Idler bracket
4. Clevis pin, washer and hairpin cotter

3. Check gap between upper control bar and upper handle when fully engaging wheel belts. Gap should be approximately 1 to 1-1/4 in. (25–32 mm) (Fig. 8).

Note: The control bar and upper handle must be parallel when in relaxed drive and brake positions.

4. Check operation. If adjustment is required, remove hairpin cotter and washer securing end of control rod to upper control bar, thread rod into or out of rod fitting to proper position and reinstall to upper control bar with washer and hairpin cotter.
5. Brake rods should be adjusted so parking brake lever can be swung into a snug position against the upper handle while pulling back on upper control bar (Fig. 8).

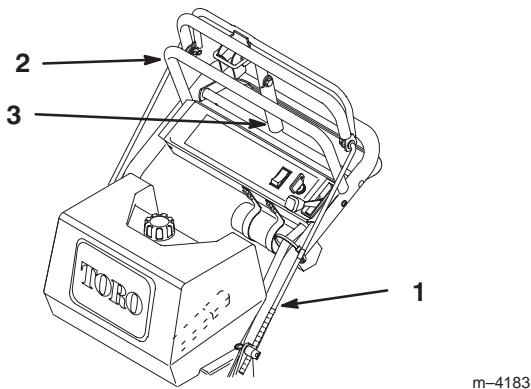

Figure 8

1. Control rod
2. Inside control bar
3. Parking brake lever

6. If an adjustment to brake rods is required, remove hairpin cotter and washer securing brake rod fitting to idler bracket (Fig. 9).

7. Adjust wing nut up or down on brake rod and resecure to idler bracket (Fig. 9). Check adjustment and readjust if necessary.

Note: Make sure brake rod is installed in forward (“F”) mounting hole in idler bracket.

8. Repeat procedure on opposite side if adjustment is required.

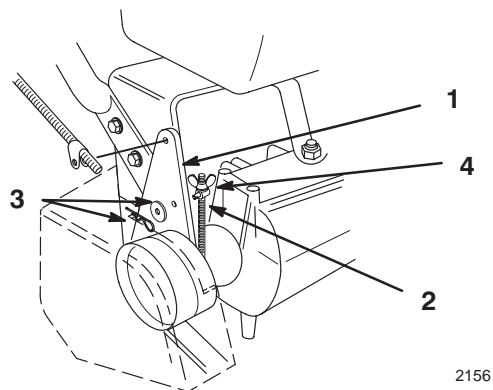

Figure 9

1. Idler bracket
2. Brake rod fitting
3. Hairpin cotter and washer
4. Wing nut

Operation

Think Safety First

Please carefully read all the safety instructions and symbols in the safety section. Knowing this information could help you, your family, pets or bystanders avoid injury.

Controls

Become familiar with all the controls (Fig. 10) before you start the engine and operate the machine.

Throttle Control – The throttle control has three positions: CHOKE, FAST and SLOW.

Deck Engagement Control Bail – Control bail used in conjunction with deck engagement switch (PTO) to release blade brake and engage clutch to drive mower blades. Release bail to disengage mower blades.

Blade Control Switch (PTO) – Rocker switch used in conjunction with control bail to release blade brake and engage clutch to drive mower blades.

Gear Shift Lever – Transmission has four forward speeds, neutral and reverse, and has an in-line shift pattern. Do not shift while unit is moving, as transmission damage may occur.

Upper Control Bar – Shift to desired gear and push forward on control bar to engage forward traction operation and pull back to brake. Pull right side of control bar to turn right and left side to turn left.

Lower Control Bar – Shift transmission to reverse and squeeze the lower control bar and handle together to engage rearward traction operation.

Parking Brake Lever – Pull back on upper control bar and swing brake lever up against the upper handle.

Ignition Switch – Key switch is used in conjunction with recoil starter. Switch has two positions: RUN and OFF.

Recoil Starter – Pull recoil Starter handle to start engine.

Fuel Shut-off Valve – (Under fuel tank) Close fuel shut-off valve when transporting or storing mower.

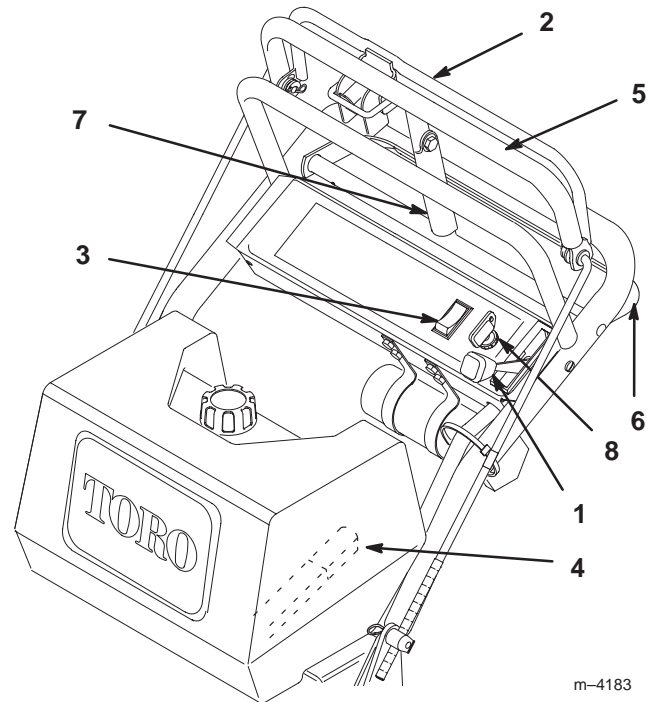

Figure 10

- | | |
|-------------------------------|------------------------|
| 1. Throttle control | 5. Upper control bar |
| 2. Blade control bail | 6. Lower control bar |
| 3. Blade control switch (PTO) | 7. Parking brake lever |
| 4. Gear shift lever | 8. Ignition switch |

Parking Brake

Always set the parking brake when you stop the machine or leave it unattended.

Setting the Parking Brake

1. Pull the upper control bar (Fig. 11) rearward and hold it in this position.
2. Lift the parking brake lock (Fig. 11) up and gradually release the upper control bar. The brake lock should stay in the set (locked) position.

Releasing the Parking Brake

1. Pull rearward on the upper control bar (Fig. 11). Lower the parking brake lock to the released position.
2. Gradually release the upper control bar.

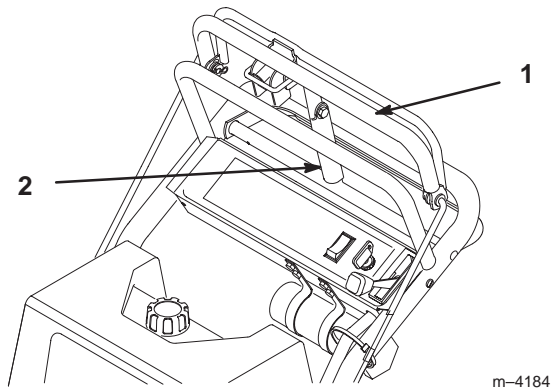

Figure 11

1. Upper control bar
2. Parking brake lock

Starting and Stopping the Engine

Starting

1. Make sure spark plug wire(s) are installed on spark plug(s) and fuel valve is open.
2. Move the shift lever to neutral, set the parking brake and turn ignition key to RUN.
3. Move the throttle control to CHOKE position before starting a cold engine.

Note: A warm or hot engine usually does not require any choking. To start a warm engine, move throttle control to FAST position.

4. Grasp recoil starter handle firmly and pull out until positive engagement results; then pull handle vigorously to start engine and allow rope to recoil slowly.

IMPORTANT: Do not pull recoil rope to its limit or let go of the starter handle when rope is pulled out because rope may break or recoil assembly may be damaged.

Stopping

1. Move the throttle lever to “SLOW” (Fig. 12).

Note: If the engine has been working hard or is hot, let it idle for a minute before turning the ignition key “OFF.” This helps cool the engine before it is stopped. In an emergency, the engine may be stopped by turning the ignition key to “OFF.”

2. Turn the ignition key to “OFF” (Fig. 12).

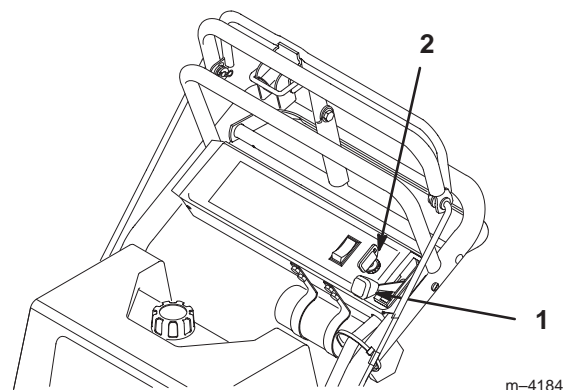

Figure 12

1. Throttle lever
2. Ignition key

3. Set the parking brake.
4. Pull wire off spark plug(s) to prevent possibility of accidental starting before storing machine.
5. Close fuel shut off valve before storing machine.

IMPORTANT: Make sure fuel shut off valve is closed before transporting or storing machine, as fuel leakage may occur.

Operating Mower Blade Control (PTO)

The blade control switch (PTO) in conjunction with the blade control bail engages and disengages power to the electric clutch and mower blades.

Engaging the Mower Blades (PTO)

1. Pull on the upper control bar to stop the machine (Fig. 13).
2. To engage blade, squeeze blade control bail against upper control bar
3. Press rocker switch forward “ON” and release. Hold blade control bail against control bar while operating.
4. Repeat procedure to engage mower blades if blade control bail is released.

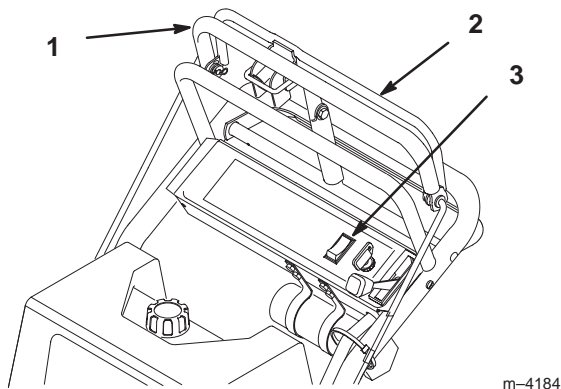

Figure 13

- | | |
|-----------------------|-------------------------------|
| 1. Upper control bar | 3. Blade control switch (PTO) |
| 2. Blade control bail | |

Disengaging the Mower Blades (PTO)

1. Releasing blade control bail to disengage blades (PTO) (Fig. 13).

The Safety Interlock System

Understanding the Safety Interlock System

The safety interlock system is designed to prevent the mower blades from rotating unless:

- The control bail is depressed
- The blade control switch (PTO) is pressed “ON”

The safety interlock system is designed to stop the mower blades if you released the blade control bail.

Testing the Safety Interlock System

Test the safety interlock system before you use the machine each time. If the safety system does not operate as described below, have an Authorized Service Dealer repair the safety system immediately.

1. Set the parking brake and start the engine :refer to Starting and Stopping the Engine, page 19
2. Squeeze the blade control bail against upper control bar. The blades should not rotate.
3. Then continue holding the blade control bail and press the rocker switch forward “ON” and release. The clutch should engage and the mower blades begin rotating.
4. Release the blade control bail. The blades should stop rotating.
5. Then push the blade control switch (PTO) to “ON” without holding the blade control bail. The blades should not rotate.

Driving Forward or Backward

The throttle control regulates the engine speed as measured in rpm (revolutions per minute). Place the throttle control in the “FAST” position for best performance.

Forward

1. To go forward, move the shift lever to a forward gear.
2. Release the parking brake: refer to Releasing the Parking Brake, page 18.
3. Slowly press on the upper control bar to move forward (Fig. 14).

To go straight, apply equal pressure to both ends of the upper control bar (Fig. 14).

To turn, release pressure on the upper control bar side away from the direction you want to turn (Fig. 14).

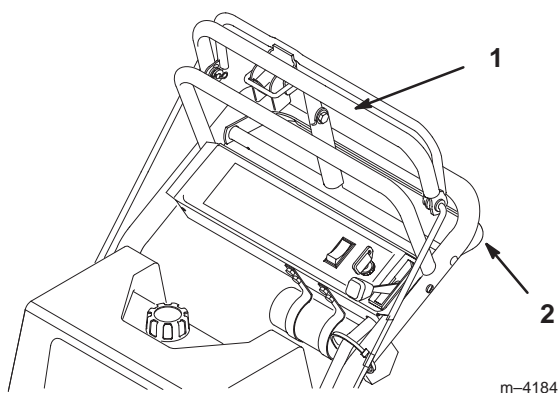

Figure 14

1. Upper control bar

2. Lower control bar

Backward

1. To go backward, move the shift lever to reverse gear.
2. Release the parking brake: refer to Releasing the Parking Brake, page 18.
3. Slowly squeeze the lower control bar and handle together to move rearward (Fig. 14).

To go straight, apply equal pressure to both ends of the lower control bar (Fig. 14).

To turn, release pressure on the lower control bar side in the direction you want to turn (Fig. 14).

Lower Control Bar Operation

This procedure is for driving up a curb. This can be performed while driving forward or backward.

1. Disengage the mower blades.

WARNING

POTENTIAL HAZARD

- A blade can be bent or damaged when driving up a curb. Blades could break apart and pieces could be thrown at bystanders or at you as you use the mower.

WHAT CAN HAPPEN

- Pieces of blade that may be thrown could seriously injure or kill you or bystanders.

HOW TO AVOID THE HAZARD

- Do not run blades while driving up a curb forward or backward.

2. Select first gear or reverse to drive machine.
3. Drive machine until drive wheels contact curb (Fig. 16).

Note: Both drive wheels should contact the curb and castor wheels straight.

4. At the same time engage lower control bar and lift up on handle (Fig. 15 and 16).

Note: Lifting up on handle will assist driving the machine up a curb and not spin the drive wheels.

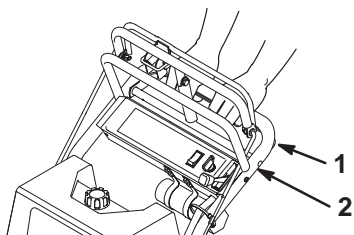
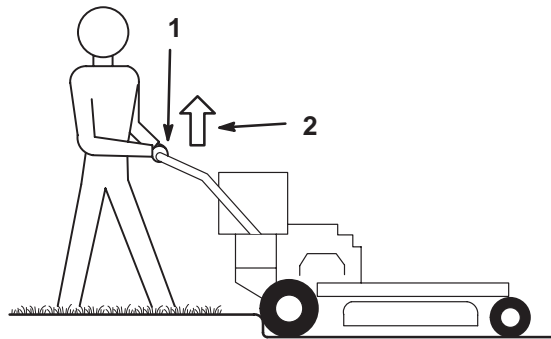

Figure 15

1. Lower Control Bar (Engaged)

1. Handle



m-4185

Figure 16

1. Lower Control Bar engaged and mower in reverse.

2. Pull up to assist machine

Stopping the Machine

To stop the machine, pull back on the upper control bar, release the blade control bail (PTO), and turn the ignition key to “OFF” to stop the engine. Also set the parking brake if you leave the machine unattended; refer to Setting the Parking Brake, page 18. Remember to remove the key from the ignition switch.

CAUTION

POTENTIAL HAZARD

- Someone could move or attempt to operate the machine while it is unattended.

WHAT CAN HAPPEN

- Children or bystanders may be injured if they use the machine.

HOW TO AVOID THE HAZARD

- Always remove the ignition key and set the parking brake when leaving the machine unattended, even if just for a few minutes.

m-4186

Maintenance

Service Interval Chart

Service Operation	Each Use	8 Hours	25 Hours	50 Hours	100 Hours	250 Hours	Storage Service
Oil—check level	X						X
Oil—change*		Initial			X		X
Safety System—check	X						X
Brake—check	X	X					X
Wheel Bearings—grease*		X					X
Transmission Couplings—grease*						X	X
Foam Air Cleaner—service*			X				X
Paper Air Cleaner—replace*					X		X
Spark Plug(s)—check			X		X		X
Belts—check for wear/cracks				X			X
Electric Clutch—Adjust					X		X
Gasoline—drain							X
Engine—clean outside	X				X		X
Fuel Filter—replace					X		X
Tires—check pressure			X				X
Chipped Surfaces—paint							X
* More often in dusty, dirty conditions							

CAUTION

POTENTIAL HAZARD

- If you leave the key in the ignition switch, someone could start the engine.

WHAT CAN HAPPEN

- Accidental starting of the engine could seriously injure you or other bystanders.

HOW TO AVOID THE HAZARD

- Remove the key from the ignition switch and pull the wire(s) off the spark plug(s) before you do any maintenance. Also push the wire(s) aside so it does not accidentally contact the spark plug(s).

Air Cleaner

Service Interval/Specification

Foam Element: Clean and re-oil after every 25 operating hours.

Paper Element: Replace after every 100 operating hours.

Note: Service the air cleaner more frequently (every few hours) if operating conditions are extremely dusty or sandy.

Removing the Foam and Paper Elements

1. Disengage the power take off (PTO), set the parking brake, and turn the ignition key to "OFF" to stop the engine. Remove the key.
2. Clean around the air cleaner to prevent dirt from getting into the engine and causing damage. Unscrew the cover nuts and remove the air cleaner cover (Fig. 17).
3. Remove the air cleaner assembly (Fig. 17).
4. Carefully slide the foam element off the paper element (Fig. 17).

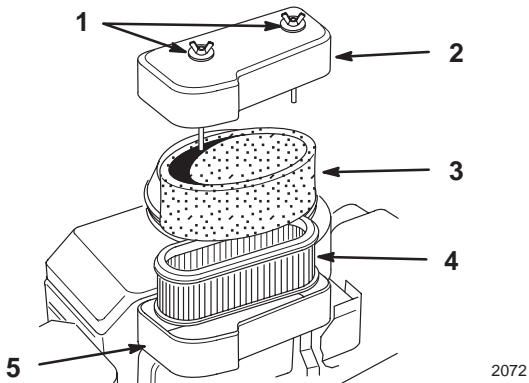

Figure 17

- | | |
|----------------------|---------------------|
| 1. Cover nut | 4. Paper element |
| 2. Air cleaner cover | 5. Air cleaner base |
| 3. Foam element | |

Cleaning the Foam and Paper Elements

1. Foam Element
 - A. Wash the foam element in liquid soap and warm water. When the element is clean, rinse it thoroughly.
 - B. Dry the element by squeezing it in a clean cloth.
 - C. Put one or two ounces of oil on the element (Fig. 18). Squeeze the element to distribute the oil.

IMPORTANT: Replace the foam element if it is torn or worn.

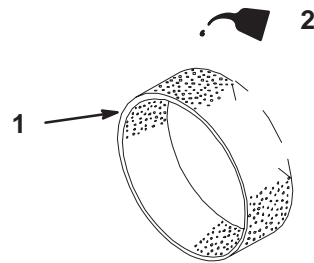

Figure 18

- | | |
|-----------------|--------|
| 1. Foam element | 2. Oil |
|-----------------|--------|

2. Paper Element

- A. Lightly tap the element on a flat surface to remove dust and dirt (Fig. 19).
- B. Inspect the element for tears, an oily film, and damage to the rubber seal.

IMPORTANT: Never clean the paper element with pressurized air or liquids, such as solvent, gas, or kerosene. Replace the paper element if it is damaged, defective, or cannot be cleaned thoroughly.

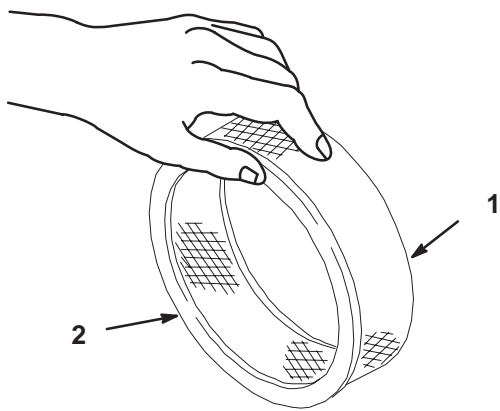

1213

Figure 19

1. Paper element
2. Rubber seal

Installing the Foam and Paper Elements

1. Installing the Foam and Paper Elements

IMPORTANT: To prevent engine damage, always operate the engine with the complete foam and paper air cleaner assembly installed.

1. Carefully slide the foam element onto the paper air cleaner element (Fig. 17).
2. Place the air cleaner assembly onto the air cleaner base (Fig. 17).
3. Install the air cleaner cover and secure with cover nuts (Fig. 17).

Engine Oil

Service Interval/Specification

Change oil:

- After the first 8 operating hours.
- After every 100 operating hours.

Note: Change oil more frequently when operating conditions are extremely dusty or sandy.

Oil Type: Detergent oil (API service SF, SE/CC, CD or SE)

Crankcase Capacity: w/filter, 1.1 l (48 oz.)

Viscosity: See table below

USE THESE SAE VISCOSITY OILS

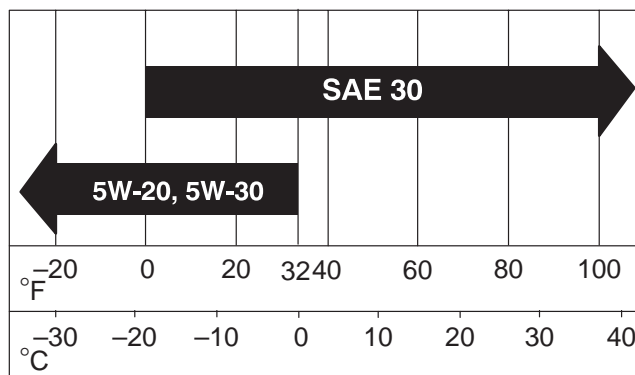

Checking Oil Level

1. Park the machine on a level surface, disengage the power take off (PTO), set the parking brake, and turn the ignition key to “OFF” to stop the engine. Remove the key.
2. Clean around the oil dipstick (Fig. 20) so dirt cannot fall into the filler hole and damage the engine.
3. Unscrew the oil dipstick and wipe the metal end clean (Fig. 20).
4. Slide the oil dipstick fully into the filler tube, do not thread onto tube (Fig. 20). Pull the dipstick out and look at the metal end. If oil level is low, slowly pour only enough oil into the filler tube to raise the level to the “FULL” mark.

IMPORTANT: Do not overfill the crankcase with oil because the engine may be damaged.

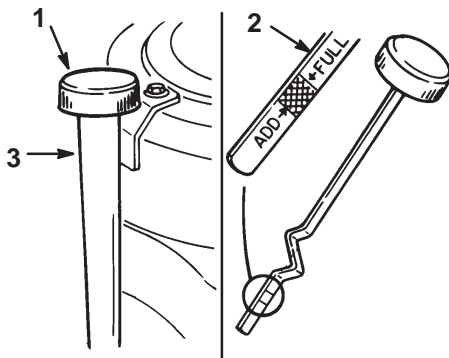

Figure 20

1. Oil dipstick
2. Metal end
3. Filler tube

Changing/Draining Oil

1. Start the engine and let it run five minutes. This warms the oil so it drains better.
2. Park the machine so that the drain side is slightly lower than the opposite side to assure the oil drains completely. Then disengage the power take off (PTO), set the parking brake, and turn the ignition key to “OFF” to stop the engine. Remove the key.
3. Place a pan below the oil drain. Remove the oil drain plug (Fig. 21).
4. When oil has drained completely, install the oil drain plug.

Note: Dispose of the used oil at a certified recycling center.

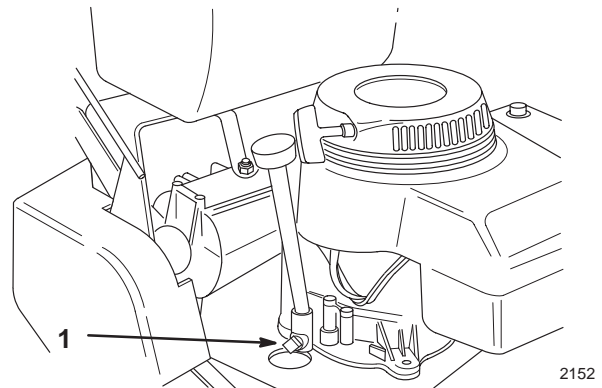

Figure 21

1. Oil drain plug

5. Slowly pour approximately 80% of the specified amount of oil specified, page 25, into the filler tube (Fig. 20). Now check the oil level; refer to Checking Oil Level, page 26. Slowly add additional oil to bring to “FULL” mark on dipstick.

Change Oil Filter

Service Interval/Specification

Replace the oil filter every 200 hours or every other oil change.

Note: Change oil filter more frequently when operating conditions are extremely dusty or sandy.

1. Drain the oil from the engine; refer to Changing/Draining Oil, page 26.
2. Remove the old filter and wipe the filter adapter (Fig. 22) gasket surface.
3. Apply a thin coat of new oil to the rubber gasket on the replacement filter (Fig. 22).

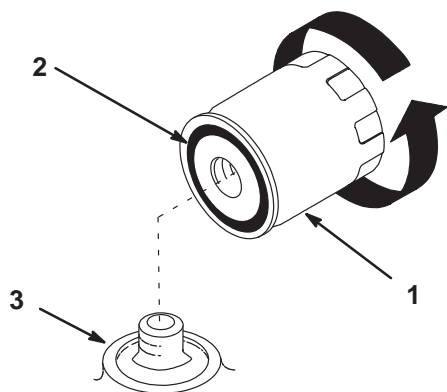

m-1256

Figure 22

1. Oil filter
2. Gasket
3. Adapter

4. Install the replacement oil filter to the filter adapter. Turn the oil filter clockwise until the rubber gasket contacts the filter adapter, then tighten the filter an additional 3/4 turn (Fig. 22).
5. Fill the crankcase with the proper type of new oil; refer to Changing/Draining Oil, page 26.

Spark Plug

Service Interval/Specification

Check the spark plug(s) after every 200 operating hours. Make sure the air gap between the center and side electrodes is correct before installing the spark plug. Use a spark plug wrench for removing and installing the spark plug(s) and a gapping tool/feeler gauge to check and adjust the air gap. Install a new spark plug(s) if necessary.

Type: NGK BMR-4A, Champion RCJ-8
(or equivalent) Air Gap: 0.65 mm (0.025 in.)

Removing the Spark Plug(s)

1. Disengage the power take off (PTO), set the parking brake, and turn the ignition key to "OFF" to stop the engine. Remove the key.
2. Pull the wire(s) off the spark plug(s) (Fig. 23). Now clean around the spark plug(s) to prevent dirt from falling into the engine and potentially causing damage.
3. Remove the spark plug(s) and metal washer.

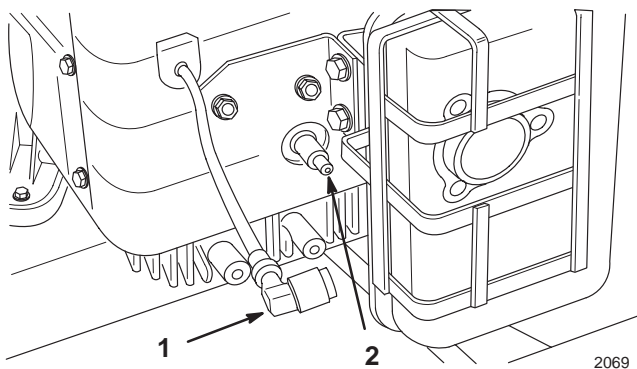

Figure 23

1. Spark plug wire
2. Spark plug

Checking the Spark Plug

1. Look at the center of the spark plug(s) (Fig. 24). If you see light brown or gray on the insulator, the engine is operating properly. A black coating on the insulator usually means the air cleaner is dirty.

IMPORTANT: Never clean the spark plug(s). Always replace the spark plug(s) when it has: a black coating, worn electrodes, an oily film, or cracks.

2. Check the gap between the center and side electrodes (Fig. 24). Bend the side electrode (Fig. 24) if the gap is not correct.

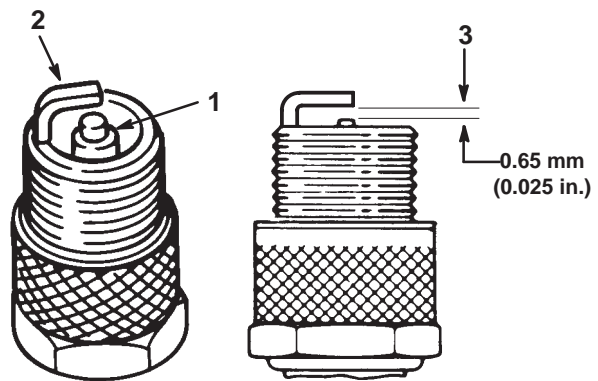

Figure 24

1. Center electrode insulator
2. Side electrode
3. Air gap (not to scale)

Installing the Spark Plug(s)

1. Install the spark plug(s) and metal washer. Make sure the air gap is set correctly.
2. Tighten the spark plug(s) to 24 N.m (18 ft-lb).
3. Push the wire(s) onto the spark plug(s) (Fig. 23).

Greasing and Lubrication

Service Interval/Specification

Grease the wheel bearings every 8 operating hours and the transmission couplers every 250 operating hours. Grease more frequently when operating conditions are extremely dusty or sandy.

Grease Type: General-purpose grease.

How to Grease

1. Disengage the power take off (PTO), set the parking brake, and turn the ignition key to "OFF" to stop the engine. Remove the key.
2. Clean the grease fittings with a rag. Make sure to scrape any paint off the front of the fitting(s).
3. Connect a grease gun to the fitting. Pump grease into the fittings until grease begins to ooze out of the bearings.
4. Wipe up any excess grease.

Where to Add Grease

1. Lubricate the wheel bearings and front spindles until grease begins to ooze out of the bearings (Fig. 25).

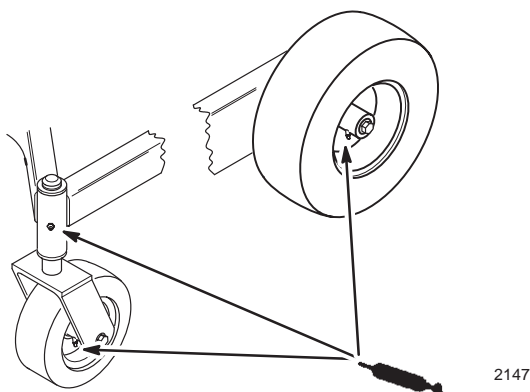
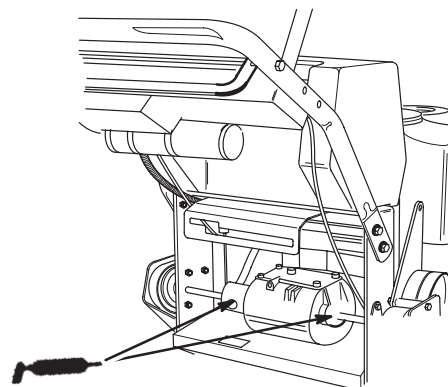

Figure 25

2. Lubricate the transmission couplers (Fig. 26). Guard does not have to be removed if you go in from the front, next to engine.



m-4189

Figure 26

Tire Pressure

Service Interval/Specification

Maintain the air pressure in the front and rear tires as specified. Check the pressure at the valve stem after every 50 operating hours or monthly, whichever occurs first (Fig. 27). Check the tires when they are cold to get the most accurate pressure reading.

Pressure: 103 kPa (15 psi) rear tires
172–207 kPa (25–30 psi) castor tires

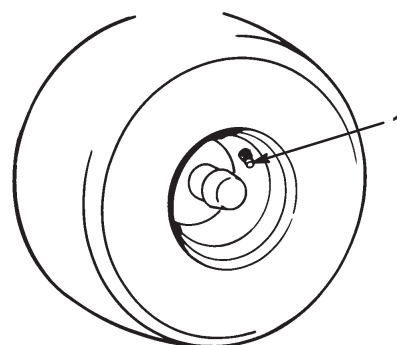

Figure 27

1. Valve stem

Brake

Always set the parking brake when you stop the machine or leave it unattended. If the parking brake does not hold securely, an adjustment is required.

Checking the Brake

1. Park the machine on a level surface, disengage the power take off (PTO), set the parking brake, and turn the ignition key to “OFF” to stop the engine. Remove the key.
2. Rear wheels must lock when you try to push the machine forward. Adjustment is required if the wheels turn and do not lock; refer to Adjusting the Brake, page 30.
3. Release the brake and press upper control bar very lightly, approximately 13 mm (1/2 in.), wheels should rotate freely.
4. If both conditions are met no adjustment is required.

Adjusting the Brake

The brake lever is on the upper control bar (Fig. 10). If the parking brake does not hold securely, an adjustment is required.

1. Check the brake before you adjust it; refer to Checking the Brake, page 30.
2. Release the parking brake; refer to Releasing the Parking Brake, page 18.
3. Remove the belt cover (Fig. 28) (3) bolts.
4. To adjust the brake remove the cotter pin and washer from the brake lever (Fig. 28).
5. Rotate the trunnion so it smoothly slides into brake lever (Fig. 28). Tighten wing nut.
6. Secure trunnion to brake lever with washer and cotter pin (Fig. 28). Replace the belt cover.
7. Check the brake operation again; refer to Checking the Brake, page 30.

IMPORTANT: With the parking brake released, the rear wheels must rotate freely when you push the mower. If brake action and free wheel rotation cannot be achieved contact your service dealer immediately.

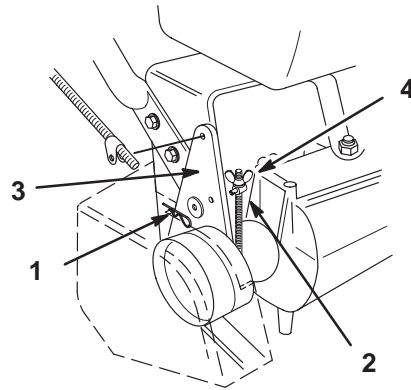

2156

Figure 28

- | | |
|------------------------------|----------------|
| 1. Hairpin cotter and washer | 3. Brake lever |
| 2. Trunnion | 4. Wing nut |

Fuel Tank

Draining The Fuel Tank

DANGER

POTENTIAL HAZARD

- In certain conditions gasoline is extremely flammable and highly explosive.

WHAT CAN HAPPEN

- A fire or explosion from gasoline can burn you, others, and cause property damage.

HOW TO AVOID THE HAZARD

- Drain gasoline from the fuel tank when the engine is cold. Do this outdoors in an open area. Wipe up any gasoline that spills.
- Never drain gasoline near an open flame or where gasoline fumes may be ignited by a spark.
- Never smoke a cigarette, cigar or pipe.

1. Park the machine on a level surface, to assure fuel tank drains completely. Then disengage the power take off (PTO), set the parking brake, and turn the ignition key to "OFF" to stop the engine. Remove the key.
2. Close fuel shut-off valve at fuel tank (Fig. 29).
3. Squeeze the ends of the hose clamp together and slide it up the fuel line away from valve (Fig. 29).
4. Pull the fuel line off the valve (Fig. 29). Open fuel shut-off valve and allow gasoline to drain into a gas can or drain pan.

Note: Now is the best time to install a new fuel filter because the fuel tank is empty. Refer to Replacing the Fuel Filter; page 32.

5. Install the fuel line onto the valve. Slide the hose clamp close to the valve to secure the fuel line.

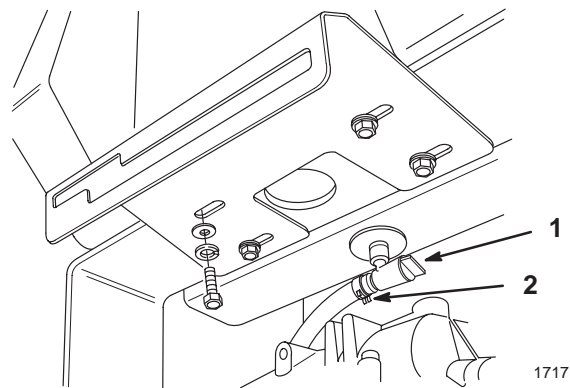

Figure 29

1. Fuel shut-off valve 2. Clamp

Fuel Filter

Service Interval/Specification

Replace the fuel filter after every 100 operating hours or yearly, whichever occurs first.

Replacing the Fuel Filter

Never install a dirty filter if it is removed from the fuel line.

1. Disengage the power take off (PTO), set the parking brake, and turn the ignition key to “OFF” to stop the engine. Remove the key.
2. Close fuel shut-off valve at fuel tank (Fig. 29).
3. Squeeze the ends of the hose clamps together and slide them away from the filter (Fig. 30).
4. Remove the filter from the fuel lines.
5. Install a new filter and move the hose clamps close to the filter.
6. Open fuel shut-off valve at fuel tank (Fig. 29).

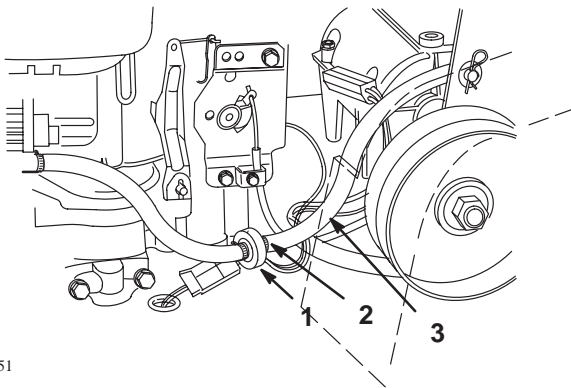

2151

Figure 30

- | | |
|---------------|-----------|
| 1. Hose clamp | 3. Filter |
| 2. Fuel line | |

Replacing the Drive Belt

1. Remove belt guard, not shown for clarity.
2. Remove top capscrew securing idler support and idler bracket to rear frame (Fig. 31).
3. Loosen bottom two mounting screws enough to allow belt to pass between drive pulley and idler support (Fig. 31).
4. Raise wheel off ground enough to allow belt removal.

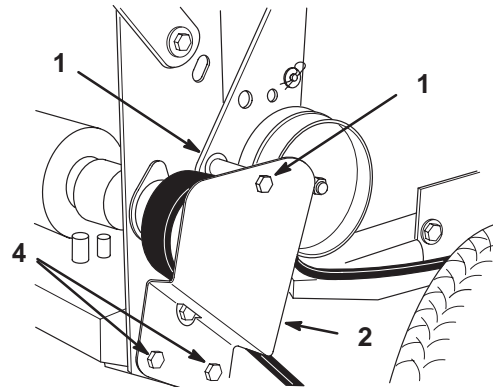

1722

Figure 31

- | | |
|------------------|--------------------|
| 1. Top capscrew | 3. Idler support |
| 2. Idler bracket | 4. Bottom capscrew |

Cleaning the Cooling System

Service Interval/Specification

Before each use, check and clean engine cooling system. Remove any build-up of grass, dirt or other debris from the cylinder and cylinder head cooling fins, air intake screen on flywheel end, and carburetor-governor levers and linkage. This will help insure adequate cooling and correct engine speed and will reduce the possibility of overheating and mechanical damage to the engine.

Replacing the Traction Belt

1. Raise the front of the machine and hold with jack stands. Remove lower shield (4) bolts.
2. Disconnect in-line wire connector from wire harness to electric clutch.
3. Remove left front engine mounting bolt securing clutch retainer to frame (Fig. 32). Unhook retainer from clutch and remove retainer.
4. Unhook tension spring from side of frame (Fig. 32).
5. Loosen pivot bolt enough to remove traction belt from the drive pulley and clutch.
6. Install new belt around clutch and drive pulley.
7. Torque pivot bolt to 47-54 N.m (35-40 ft. lb.) Install tension spring between idler arm and frame bracket (Fig. 32).
8. Hook clutch retainer into clutch and secure to frame with engine mounting bolt. Torque engine mounting bolt to 19-24 N.m (170-220 in. lb.)
9. Connect clutch in-line wire connector to wire harness.
10. Install lower shield.

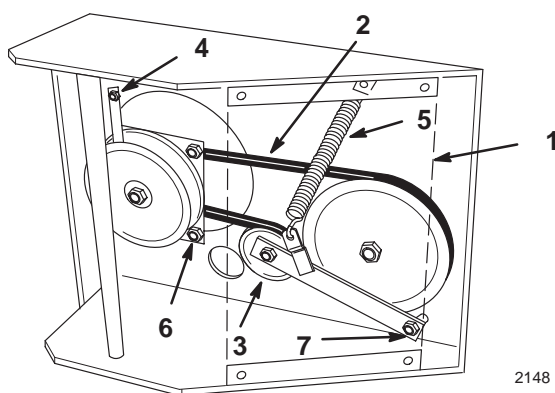

Figure 32

- | | |
|--------------------|-------------------|
| 1. Lower Shield | 5. Tension spring |
| 2. Traction belt | 6. Adjusting nut |
| 3. Idler pulley | 7. Pivot bolt |
| 4. Clutch retainer | |

Adjusting the Electric Clutch

The clutch is adjustable to ensure proper engagement and proper braking. Check adjustment after every 100 hours of operation.

1. To adjust clutch, tighten or loosen lock nuts on flange studs (Fig. 33).
2. Check adjustment by inserting feeler gauge thru slots next to studs (Fig. 33).
3. The proper disengaged clearance between the clutch plates is 0.30-0.45 mm (.012-.018 in.). It will be necessary to check this clearance at each of the three slots to ensure the plates are parallel to each other.

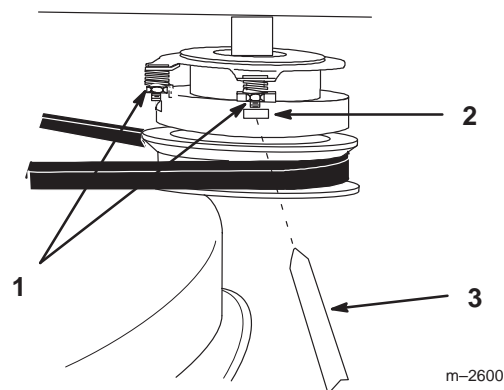
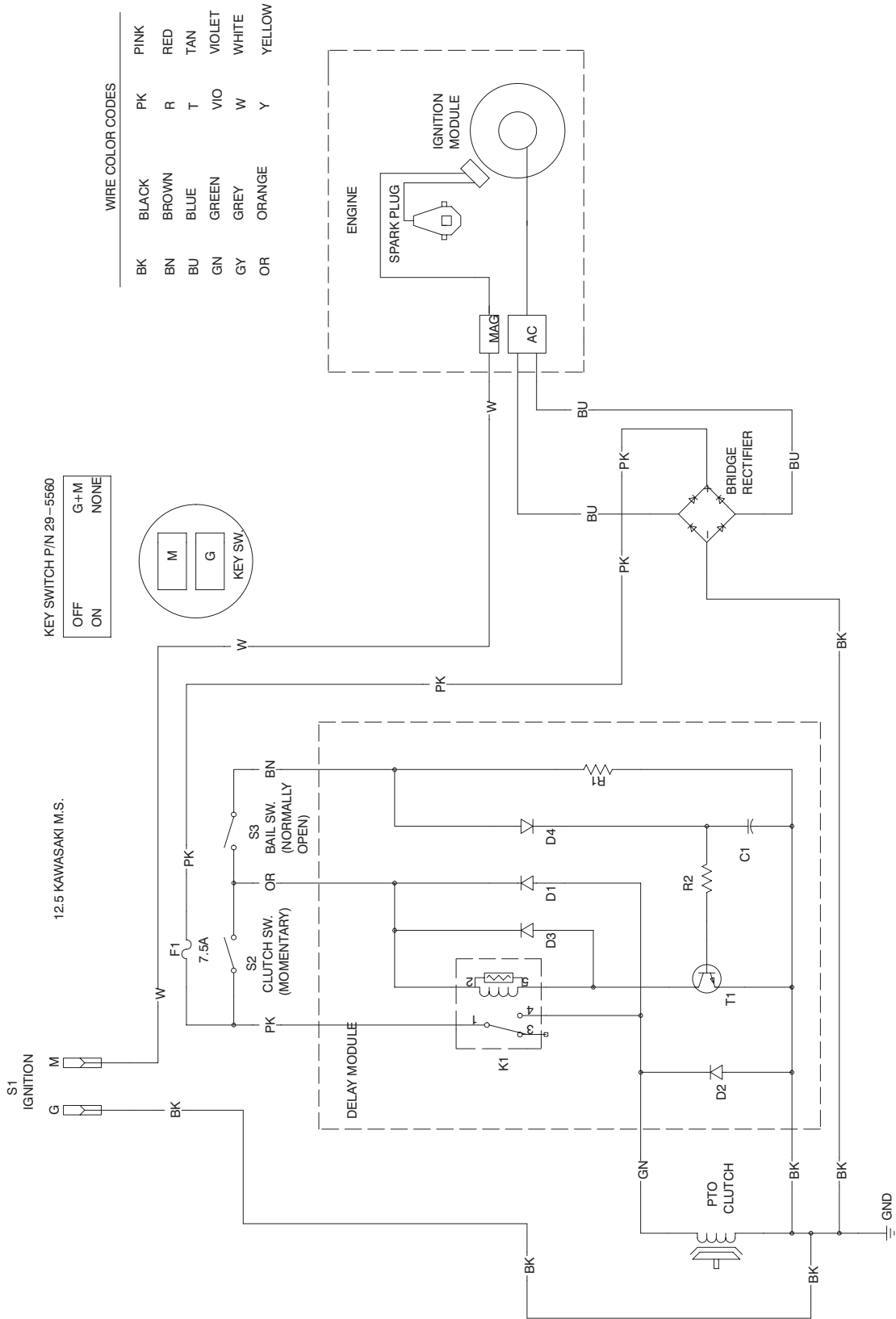

Figure 33

- | | |
|------------------|-----------------|
| 1. Adjusting nut | 3. Feeler gauge |
| 2. Slot | |

Wiring Diagram



Cleaning and Storage

1. Disengage the power take off (PTO), set the parking brake, and turn the ignition key to “OFF” to stop the engine. Remove the key.
2. Remove grass clippings, dirt, and grime from the external parts of the entire machine, especially the engine. Clean dirt and chaff from the outside of the engine’s cylinder head fins and blower housing.

IMPORTANT: You can wash the machine with mild detergent and water. Do not pressure wash the machine. Avoid excessive use of water, especially near the control panel, and engine.

3. Check the brake; refer to Brake, page 30.
4. Service the air cleaner; refer to Air Cleaner, page 24.
5. Grease the machine; refer to Greasing and Lubrication, page 29.
6. Change the crankcase oil; refer to Engine Oil, page 25.
7. Remove the spark plug(s) and check its condition; refer to Spark Plug, page 28. With the spark plug(s) removed from the engine, pour two tablespoons of engine oil into the spark plug hole. Now use the starter to crank the engine and distribute the oil inside the cylinder. Install the spark plug(s). Do not install the wire on the spark plug(s).
8. Check the tire pressure; refer to Tire Pressure, page 29.

9. For storage over 30 days, prepare the traction unit as follows.
 - A. Add a petroleum based stabilizer/conditioner to fuel in the tank. Follow mixing instructions from stabilizer manufacturer. (1 oz. per gallon). **Do not use an alcohol based stabilizer (ethanol or methanol).**

Note: A fuel stabilizer/conditioner is most effective when mixed with fresh gasoline and used at all times.

- B. Run the engine to distribute conditioned fuel through the fuel system (5 minutes).
- C. Stop the engine, allow it to cool and drain the fuel tank; refer to Draining Fuel Tank, page 31.
- D. Restart the engine and run it until it stops.
- E. Choke or prime the engine.
- F. Start and run the engine until it will not start again. Use the primer, if equipped on machine, several times to ensure no fuel remains in primer system.
- G. Dispose of fuel properly. Recycle as per local codes.

IMPORTANT: Do not store stabilizer/conditioned gasoline over 90 days.

10. Check and tighten all bolts, nuts, and screws. Repair or replace any part that is damaged or defective.
11. Paint all scratched or bare metal surfaces. Paint is available from your Authorized Service Dealer.
12. Store the machine in a clean, dry garage or storage area. Remove the key from the ignition switch and keep it in a memorable place. Cover the machine to protect it and keep it clean.

Troubleshooting

PROBLEM	POSSIBLE CAUSES	CORRECTIVE ACTION
Engine will not start, starts hard, or fails to keep running.	<ol style="list-style-type: none"> 1. Fuel tank is empty. 2. Choke is not ON. 3. Air cleaner is dirty. 4. Spark plug wire is loose or disconnected. 5. Spark plug is pitted, fouled, or gap is incorrect. 6. Dirt in fuel filter. 7. Dirt, water, or stale fuel is in fuel system. 	<ol style="list-style-type: none"> 1. Fill fuel tank with gasoline. 2. Move choke lever to ON. 3. Clean or replace air cleaner element. 4. Install wire on spark plug. 5. Install new, correctly gapped spark plug. 6. Replace fuel filter. 7. Contact Authorized Service Dealer.
Engine loses power.	<ol style="list-style-type: none"> 1. Engine load is excessive. 2. Air cleaner is dirty. 3. Oil level in crankcase is low. 4. Cooling fins and air passages under engine blower housing are plugged. 5. Spark plug is pitted, fouled, or gap is incorrect. 6. Vent hole in fuel cap is plugged. 7. Dirt in fuel filter. 8. Dirt, water, or stale fuel is in fuel system. 	<ol style="list-style-type: none"> 1. Reduce ground speed. 2. Clean air cleaner element. 3. Add oil to crankcase. 4. Remove obstruction from cooling fins and air passages. 5. Install new, correctly gapped spark plug. 6. Clean or replace the fuel cap. 7. Replace fuel filter. 8. Contact Authorized Service Dealer.
Engine over heats.	<ol style="list-style-type: none"> 1. Engine load is excessive. 2. Oil level in crankcase is low. 3. Cooling fins and air passages under engine blower housing are plugged. 	<ol style="list-style-type: none"> 1. Reduce ground speed. 2. Add oil to crankcase. 3. Remove obstruction from cooling fins and air passages.
Abnormal vibration.	<ol style="list-style-type: none"> 1. Engine mounting bolts are loose. 2. Loose engine pulley, idler pulley, or blade pulley. 3. Engine pulley is damaged. 	<ol style="list-style-type: none"> 1. Tighten engine mounting bolts. 2. Tighten the appropriate pulley. 3. Contact Authorized Service Dealer.

PROBLEM	POSSIBLE CAUSES	CORRECTIVE ACTION
Machine does not drive.	<ol style="list-style-type: none">1. Shift lever is in NEUTRAL.2. Traction belt is worn, loose or broken.3. Traction belt is off pulley.	<ol style="list-style-type: none">1. Move shift lever to a drive gear position.2. Contact Authorized Service Dealer.3. Contact Authorized Service Dealer.

