



38" Side Discharge Cutting Unit

Model No. 78216-20000001 and Up

Parts Catalog

Ordering Replacement Parts

To order replacement parts, please supply: the part number, the quantity, and the description of each part desired.

Understanding Reference Numbers

Each identified part in an illustration has a reference number. The reference number for a part also appears in the parts list, along with other information about the part.

This catalog uses two special reference number formats, one to indicate parts in a service assembly and another to indicate the quantity of a given part in an illustration.

Service Assembly Reference Numbers

Parts in service assemblies have reference numbers in the form **a:b**. The **a** represents the reference number of the entire service assembly and the **b** represents a sequential number unique to each part within the service assembly.

For example, a wheel assembly might be identified by reference number **6**, the tire by **6:1**, the valve by **6:2**, and the wheel by **6:3**. When you order the assembly identified by reference number **6**, you receive all parts identified by reference numbers **6:1**, **6:2**, and **6:3**. However, you may also order any part individually.

Reference numbers of this type appear in illustrations and in part lists.

Reference Numbers Indicating Quantity

In an illustration, if a reference number indicates more than one part, the reference number has the form **nX y**. The **n** represents the quantity of the part, the **X** is the multiplication symbol, and the **y** represents the reference number.

For example, in an illustration, the reference number **2X 37** means that two of the parts identified by reference number **37** are indicated.

Contents

Description	Page	Description	Page
Blade, Spindle And Pulley Assembly	3	Covers Assembly	5
Cutting Unit Assembly	4		

Part Description Abbreviations

Part descriptions in this catalog may include the following abbreviations.

Abbreviation	Meaning	Abbreviation	Meaning
AR	as required	INC	incorporated
ASM	assembly	LH	left hand
CARR	carriage	NI	nylon insert
DEG	degrees	PPH	Phillips pan head
FH	flat head	PTH	Phillips truss head
GA	gauge	PTO	power take off
HF	hex flange	RH	right hand
HH	hex head	SFH	slotted fillister head
HHF	hex head flange	SHH	slotted hex head
HLH	hex lag head	SQH	square head
HJ	hex jam	SHWH	slotted hex washer head
HOC	height-of-cut	SPH	slotted pan head
HS	hex socket	SRH	slotted round head
HSBH	hex socket button head	STD	standard
HSFH	hex socket flat head	TAP	self tapping
HSH	hex socket head	TTH	Torx truss head
HWH	hex washer head	WH	wing head
HWHTF	hex washer head thread forming		

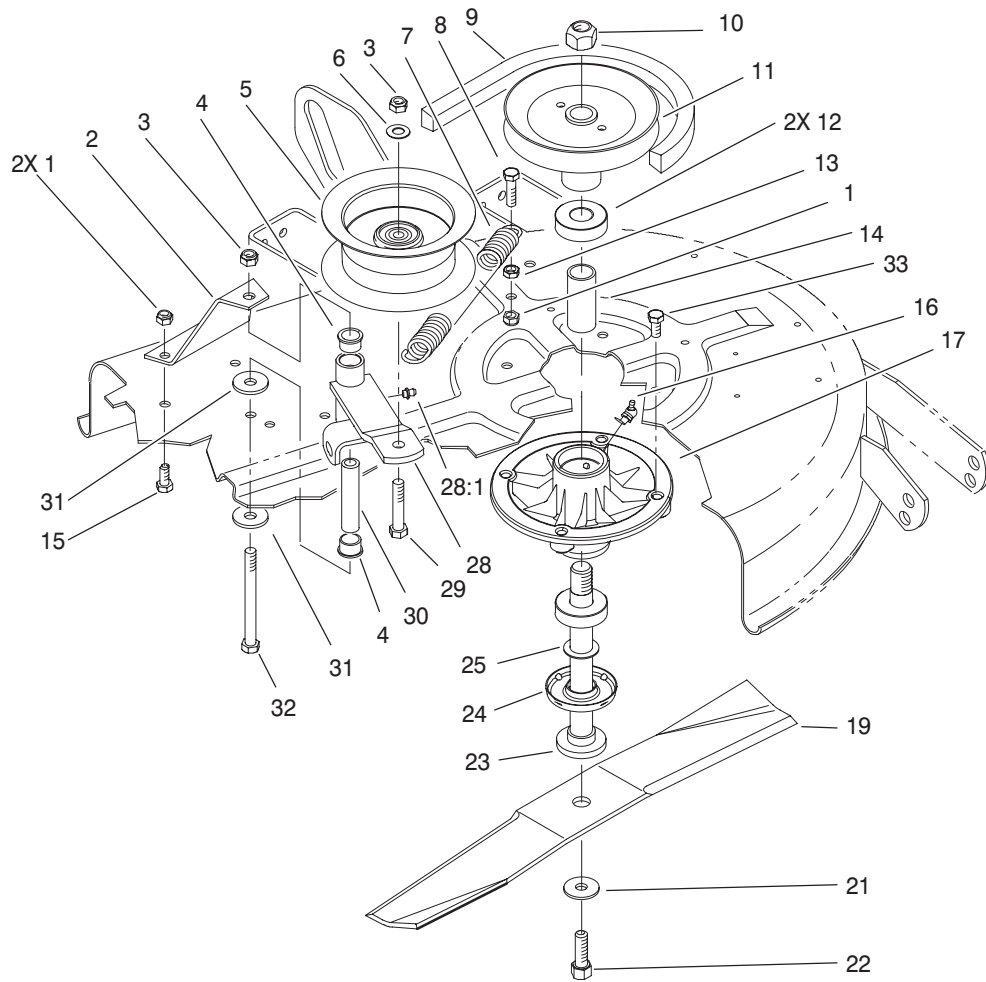

Sheet No.:2

Blade, Spindle And Pulley Assembly

Ref. No.	Part No.	Qty.	Description
1	3296-29	3	Nut-Lock, NI
2	78-8091-03	1	Brace
3	3296-39	2	Nut-Lock, NI
4	109859	2	Bushing
5	92-7082	1	Pulley - Idler
6	3256-24	1	Washer-Flat
7	78-6210	1	Spring-Extension
8	322-6	1	Screw-HH
9	92-7066	1	Belt - V
10	3219-6	2	Nut-Hex
11	100-3546	2	Pulley
12	109966	4	Bearing-Ball
13	3217-6	1	Nut-Hex
14	62-3661	2	Spacer-Bearing
15	322-3	2	Screw-HH
16	302-11	2	Fitting-Lube,45°
17	100-3547	2	Housing-Spindle
19	57-4700	2	Blade
21	112843	2	Washer
22	26-0671	2	Screw-Blade
23	100-3548	2	Shaft-Spindle
24	80-4370	2	Shield - Bearing
25	80-4380	2	Spacer
28	94-9795	1	Arm-Idler
28:1	302-5	1	Fitting-Lube
29	323-10	1	Screw-HH

Ref. No.	Part No.	Qty.	Description
30	109950	1	Spacer
31	2844	2	Washer
32	323-16	1	Screw-HH
33	32144-41	8	Screw-Taptite

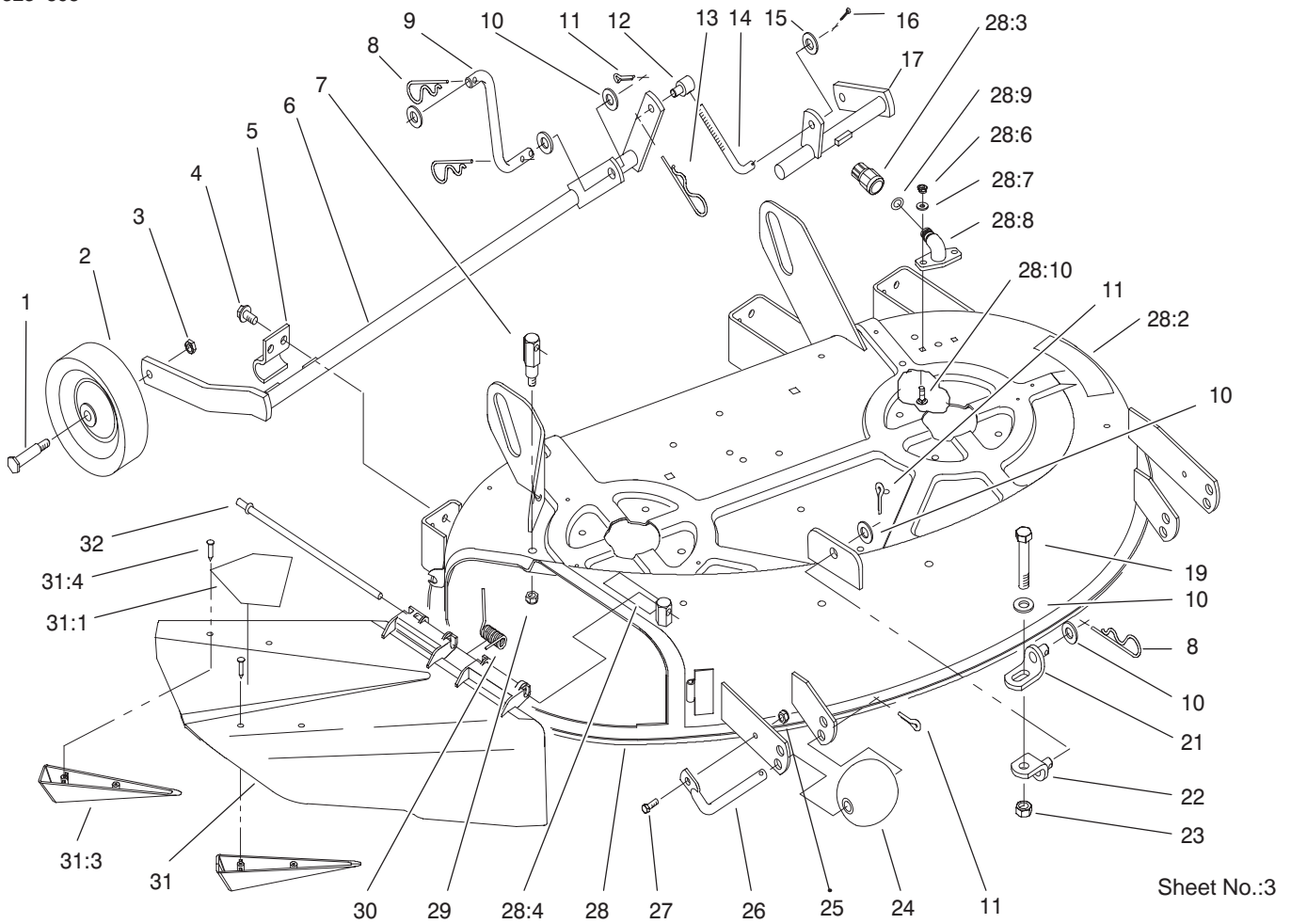

Sheet No.:3

Cutting Unit Assembly

Ref. No.	Part No.	Qty.	Description
1	92-1057	2	Bolt-Shoulder
2	92-6959	2	Wheel
3	32146-2	2	Nut-Lock, NI
4	9267154	6	Screw
5	78-6400-03	3	Clamp
6	78-8011-03	1	Shaft - RH
7	92-7063	1	Pivot Post - Rear
8	9335064	3	Pin-Hair
9	78-8071	1	Link-Rear
10	3256-26	6	Washer-Flat
11	3272-21	4	Pin-Cotter
12	101161	1	Trunion
13	9335044	1	Pin-Hair
14	121010	1	Rod-Lift
15	3256-24	1	Washer-Flat
16	3272-6	1	Pin-Cotter
17	92-7073-03	1	Shaft - LH
19	325-13	1	Screw-HH
21	86-9240	1	Bracket-Lift, Lower
22	86-9250	1	Bracket-Lift, Upper
23	3218-5	1	Nut-Jam
24	29-4820	2	Roller
25	3296-42	2	Nut-Lock
26	118960-03	2	Shaft-Roller
27	321-4	2	Screw-HH
28	92-6834	1	Deck ASM

Ref. No.	Part No.	Qty.	Description
28:2	92-7110	1	Decal - Danger
28:3	95-3270	1	Connector-Hose
28:4	92-7109	1	Decal - Caution
28:6	3296-16	2	Nut-Lock, NI
28:7	3256-1	2	Washer-Flat
28:8	95-2747	1	Fitting-Washout
28:9	46-6290	1	O-Ring
28:10	3229-1	2	Screw-CARR
29	3296-39	1	Nut-Lock, NI
30	57-6950	1	Spring
31	100-6201	1	Deflector ASM
31:1	93-1122	1	Decal-Danger
31:3	93-7696	2	Kicker
31:4	93-0231	4	Screw - PPH
32	57-4380	1	Rod-Hinge Deflector

