



ProLine
20 HP Hydro Mid-Size Traction Unit
30192—200000001 & Up

Operator's Manual

Introduction

Thank you for purchasing a Toro product.

All of us at Toro want you to be completely satisfied with your new product, so feel free to contact your local Authorized Service Dealer for help with service, genuine replacement parts, or other information you may require.

Whenever you contact your Authorized Service Dealer or the factory, always know the model and serial numbers of your product. These numbers will help the Service Dealer or Service Representative provide exact information about your specific product. You will find the model and serial number plate located in a unique place on the product as shown below.

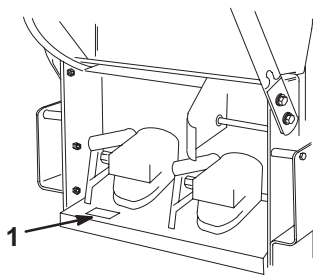

m-3097

1. Model and Serial Number Plate

For your convenience, write the product model and serial numbers in the space below.

Model No: _____
Serial No. _____

Read this manual carefully to learn how to operate and maintain your product correctly. Reading this manual will help you and others avoid personal injury and damage to the product. Although we design, produce and market safe, state-of-the-art products, you are responsible for using the product properly and safely. You are also responsible for training persons, who you allow to use the product, about safe operation.

The warning system in this manual identifies potential hazards and has special safety messages that help you and others avoid personal injury, even death. DANGER, WARNING and CAUTION are signal words used to identify the level of hazard. However, regardless of the hazard, be extremely careful.



DANGER signals an extreme hazard that will cause serious injury or death if the recommended precautions are not followed.

WARNING signals a hazard that may cause serious injury or death if the recommended precautions are not followed.

CAUTION signals a hazard that may cause minor or moderate injury if the recommended precautions are not followed.

Two other words are also used to highlight information. “Important” calls attention to special mechanical information and “Note” emphasizes general information worthy of special attention.

The left and right side of the machine is determined by sitting on the seat in the normal operator’s position.

	WARNING:	
The engine exhaust from this product contains chemicals known to the State of California to cause cancer, birth defects, or other reproductive harm.		

IMPORTANT: The engine in this product is not equipped with a spark arrester muffler. It is a violation of California Public Resource Code Section 4442 to use or operate this engine on any forest-covered, brush-covered or grass-covered land as defined in CPRC 4126. Other states or federal areas may have similar laws.

Contents

	Page		Page
Safety	2	Neutral	21
Safe Operating Practices	2	Stopping the Machine	21
Toro Mower Safety	4	Pushing the Machine by Hand	22
Slope Chart	7	Maintenance	23
Safety and Instruction Decals	9	Service Interval Chart	23
Gasoline and Oil	10	Air Cleaner	24
Recommended Gasoline	10	Engine Oil	25
Using Stabilizer/Conditioner	11	Spark Plug	27
Filling the Fuel Tank	11	Cleaning the Cooling Systems	28
Check Engine Oil Level	11	Tire Pressure	29
Assembly	12	Fuse	29
Loose Parts	12	Fuel Tank	30
Install Wheels	13	Fuel Filter	31
Install Upper Handle	13	Hydraulic System	31
Install Control Rods	13	Adjusting By-pass Valve	33
Activate the Battery	15	Replacing the Traction Belt	35
Install Battery	16	Adjusting the Electric Clutch	35
Operation	17	Adjusting Neutral	36
Think Safety First	17	Battery	37
Controls	17	Wiring Diagram	38
Starting and Stopping the Engine	18	Hydraulic Diagram	39
Operating Mower Blade Control (PTO) ..	19	Cleaning and Storage	40
The Safety Interlock System	19	Troubleshooting	41
Driving Forward or Backward	20	Warranty	Back Cover

THE ENCLOSED ENGINE OWNER'S MANUAL IS SUPPLIED FOR CALIFORNIA EMISSION CONTROL REGULATION INFORMATION ON EMISSION SYSTEMS, MAINTENANCE AND WARRANTY.

KEEP THIS ENGINE OWNER'S MANUAL WITH YOUR UNIT. SHOULD THIS ENGINE OWNER'S MANUAL BECOME DAMAGED OR ILLEGIBLE, REPLACE IMMEDIATELY. REPLACEMENTS MAY BE ORDERED THROUGH THE ENGINE MANUFACTURER.

Safety

This machine meets or exceeds CPSC blade safety requirements for rotary mowers and the B71.4 1999 specifications of the American National Standards Institute, in effect at time of production.

Note: The addition of certain attachments that do not meet American National Standards Institute certification will cause noncertification of this machine.

Improper use or maintenance by the operator or owner can result in injury. To reduce the potential for injury, comply with these safety instructions and always pay attention to the safety alert ▲ symbol, which means CAUTION, WARNING, or DANGER—“personal safety instruction.” Failure to comply with the instruction may result in personal injury or death.

Safe Operating Practices

The following instructions are from ANSI standard B71.4—1999.

Training

- Read the Operator’s Manual and other training material. If the operator(s) or mechanic(s) can not read English it is the owner’s responsibility to explain this material to them.
- Become familiar with the safe operation of the equipment, operator controls, and safety signs.
- All operators and mechanics should be trained. The owner is responsible for training the users.
- Never let children or untrained people operate or service the equipment. Local regulations may restrict the age of the operator.
- The owner/user can prevent and is responsible for accidents or injuries occurring to himself or herself, other people or property.

Preparation

- Evaluate the terrain to determine what accessories and attachments are needed to properly and safely perform the job. Only use accessories and attachments approved by the manufacturer.
- Wear appropriate clothing including hard hat, safety glasses and ear protection. Long hair, loose clothing or jewelry may get tangled in moving parts.
- Inspect the area where the equipment is to be used and remove all objects such as rocks, toys and wire which can be thrown by the machine.
- Use extra care when handling gasoline and other fuels. They are flammable and vapors are explosive.
 - Use only an approved container
 - Never remove gas cap or add fuel with engine running. Allow engine to cool before refueling. Do not smoke.
 - Never refuel or drain the machine indoors.
- Check that operator’s presence controls, safety switches and shields are attached and functioning properly. Do not operate unless they are functioning properly.

Operation

- Never run an engine in an enclosed area.
- Only operate in good light, keeping away from holes and hidden hazards.
- Be sure all drives are in neutral and parking brake is engaged before starting engine. Only start engine from the operator's position. Use seat belts if provided.
- Be sure of your footing while using pedestrian controlled equipment, especially when backing up. Walk, don't run. Never operate on wet grass. Reduced footing could cause slipping.
- Slow down and use extra care on hillsides. Be sure to travel in the recommended direction on hillsides. Turf conditions can affect the machine's stability. Use caution while operating near drop-offs.
- Slow down and use caution when making turns and when changing directions on slopes.
- Never raise deck with the blades running.
- Never operate with the PTO shield, or other guards not securely in place. Be sure all interlocks are attached, adjusted properly, and functioning property.
- Never operate with the discharge deflector raised, removed or altered, unless using a grass catcher.
- Do not change the engine governor setting or overspeed the engine.
- Stop on level ground, lower implements, disengage drives, engage parking brake (if provided), shut off engine before leaving the operator's position for any reason including emptying the catchers or unclogging the chute.
- Stop equipment and inspect blades after striking objects or if an abnormal vibration occurs. Make necessary repairs before resuming operations.
- Keep hands and feet away from the cutting units.
- Look behind and down before backing up to be sure of a clear path.
- Never carry passengers and keep pets and bystanders away.
- Slow down and use caution when making turns and crossing roads and sidewalks. Stop blades if not mowing.
- Be aware of the mower discharge direction and do not point it at anyone.
- Do not operate the mower under the influence of alcohol or drugs
- Use care when loading or unloading the machine into a trailer or truck
- Use care when approaching blind corners, shrubs, trees, or other objects that may obscure vision.

Maintenance and Storage

- Disengage drives, lower implement, set parking brake, stop engine and remove key or disconnect spark plug wire. Wait for all movement to stop before adjusting, cleaning or repairing.
- Clean grass and debris from cutting units, drives, mufflers, and engine to help prevent fires. Clean up oil or fuel spillage.
- Let engine cool before storing and do not store near flame.
- Shut off fuel while storing or transporting. Do not store fuel near flames or drain indoors.
- Park machine on level ground. Never allow untrained personnel to service machine.
- Use jack stands to support components when required.
- Carefully release pressure from components with stored energy.

- Disconnect battery or remove spark plug wire before making any repairs. Disconnect the negative terminal first and the positive last. Reconnect positive first and negative last.
- Use care when checking blades. Wrap the blade(s) or wear gloves, and use caution when servicing them. Only replace blades. Never straighten or weld them.
- Keep hands and feet away from moving parts. If possible, do not make adjustments with the engine running.
- Charge batteries in an open well ventilated area, away from spark and flames. Unplug charger before connecting or disconnecting from battery. Wear protective clothing and use insulated tools.
- Keep all parts in good working condition and all hardware tightened. Replace all worn or damaged decals.

Toro Mower Safety

The following list contains safety information specific to Toro products or other safety information that you must know that is not included in the ANSI standards.

This product is capable of amputating hands and feet and throwing objects. Always follow all safety instructions to avoid serious injury or death.

WARNING

POTENTIAL HAZARD

- **Engine exhaust contains carbon monoxide, which is an odorless, deadly poison.**

WHAT CAN HAPPEN

- **Carbon monoxide can kill you and is also known to the State of California to cause birth defects.**

HOW TO AVOID THE HAZARD

- **Do not run engine indoors or in an enclosed area.**

This product is designed for cutting and recycling grass or, when equipped with a grass bagger, for catching cut grass. Any use for purposes other than these could prove dangerous to user and bystanders.

Note: This engine is not equipped with a spark arrester muffler. It is a violation of California Public Resource Code Section 4442 to use or operate this engine on any forest-covered, brush-covered or grass-covered land. Other states or federal areas may have similar laws.

General Operation

- Allow only responsible adults who are familiar with the instructions to operate the machine.
- Be sure the area is clear of other people before mowing. Stop the machine if anyone enters the area.
- Do not mow in reverse unless absolutely necessary. Always look down and behind before and while backing.
- Be aware of the mower discharge direction and do not point it at anyone. Do not operate the mower without either the entire grass catcher or the guard in place.
- Slow down before turning. Sharp turns on any terrain may cause loss of control.
- Turn off blades when not mowing.
- Keep hands, feet, hair and loose clothing away from attachment discharge area, underside of mower and any moving parts while engine is running.
- Stop the engine before removing the grass catcher or unclogging the chute.
- Mow only in daylight or good artificial light.
- Watch for traffic when operating near or crossing roadways.

- Do not touch equipment or attachment parts which may be hot from operation. Allow to cool before attempting to maintain, adjust or service.
- Before operating a machine with ROPS (roll over protection) be certain the seat belts are attached to prevent the seat from pivoting forward.

Slope Operation

Slopes and ramps are a major factor related to loss-of-control and tip-over accidents, which can result in severe injury or death. All slopes and ramps require extra caution. If you cannot back up the slope or if you feel uneasy on it, do not mow it.

DO

- Mow up and down slopes greater than 5°, not across.
- Mow downhill only on slopes above 10°, never mow uphill. If a steep slope must be ascended, back up the hill, and drive forward down the hill, keeping the machine in gear.
- Remove obstacles such as rocks, tree limbs, etc. from the mowing area. Watch for holes, ruts or bumps, as uneven terrain could overturn the machine. Tall grass can hide obstacles.
- Use slow speed so that you will not have to stop while on the slope.
- Follow the manufacturer's recommendations for wheel weights or counterweights to improve stability.
- Use extra care with grass catchers or other attachments. These can change the stability of the machine.
- Keep all movement on slopes slow and gradual. Do not make sudden changes in speed or direction.
- Avoid starting or stopping on a slope. If tires lose traction, disengage the blades and proceed slowly straight down the slope.

- When operating machine on slopes, banks or near drop offs, always have ROPS (roll over protection) installed.
- When operating a machine with ROPS (roll over protection) always use seat belt.
- Be certain that the seat belt can be released quickly if the machine is driven or rolls into ponds or water.
- Check carefully for overhead clearances (i.e. branches, doorways, electrical wires) before driving under any objects and do not contact them.

DO NOT

- Do not operate machine on hillsides or slopes exceeding 15°.
- Avoid turning on slopes. If you must turn, turn slowly and gradually downhill, if possible.
- Do not mow near drop-offs, ditches, or embankments. The machine could suddenly turn over if a wheel goes over the edge of a cliff or ditch, or if an edge caves in.
- Do not mow on wet grass. Reduced traction could cause sliding.
- Do not try to stabilize the machine by putting your foot on the ground.
- Do not use a grass catcher on steep slopes. Heavy grass bags could cause loss of control or overturn the machine.

Service

- Never store the machine or fuel container inside where there is an open flame, such as near a water heater or furnace.
- Keep nuts and bolts tight, especially the blade attachment bolts. Keep equipment in good condition.
- Never tamper with safety devices. Check safety systems for proper operation before each use.

- Use only genuine replacement parts to ensure that original standards are maintained.
- Check brake operation frequently. Adjust and service as required.
- Battery acid is poisonous and can cause burns. Avoid contact with skin, eyes and clothing. Protect your face, eyes and clothing when working with a battery.
- Battery gases can explode. Keep cigarettes, sparks and flames away from battery.
- Hydraulic fluid escaping under pressure can penetrate the skin and cause injury. Use cardboard or paper to find hydraulic leaks.
- Never modify ROPS (roll over protection) frames or structures because they are specifically designed, sized, located and tested for injury reduction. If a rollover occurs, a modified ROPS will not provide adequate protection.

Slope Chart

Read all safety instructions on pages 2-9.

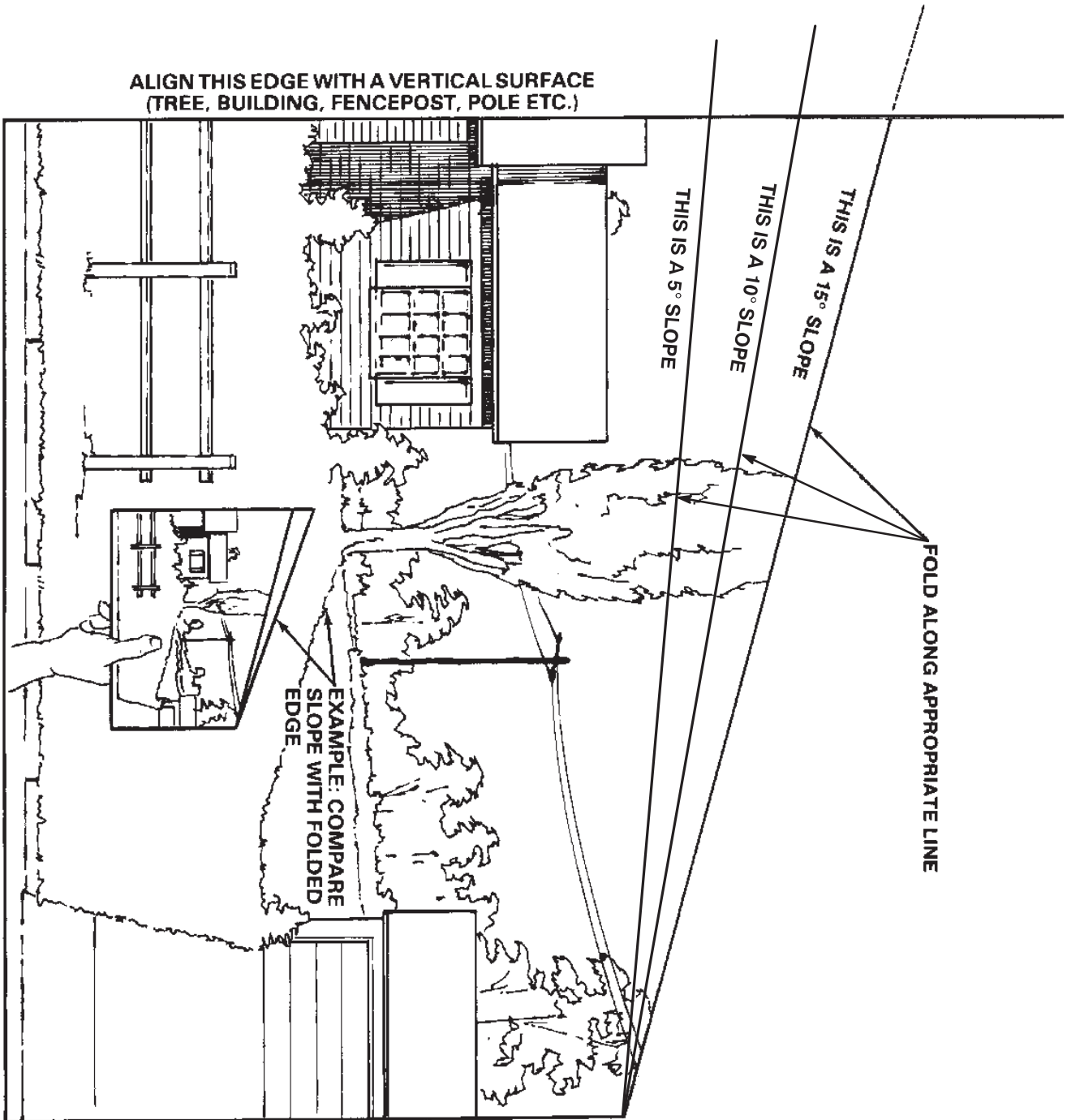

Safety and Instruction Decals



Safety decals and instructions are easily visible to the operator and are located near any area of potential danger. Replace any decal that is damaged or lost.

**ON CONTROL PANEL
(Part No. 95-1544)**

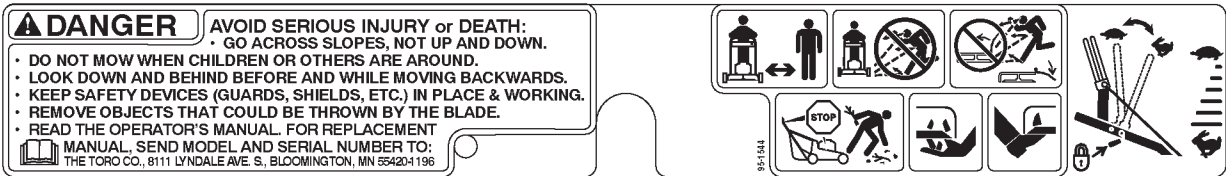

**ON CONTROL PANEL
(Part No. 95-5857)**



**ON SIDE OF HANDLE
(Part No. 95-5862)**

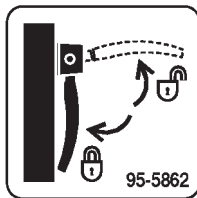

**ON OIL COOLER
(Part No. 95-2814)**

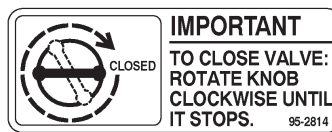

**ON SWITCH PLATE
(Part No. 95-1523)**

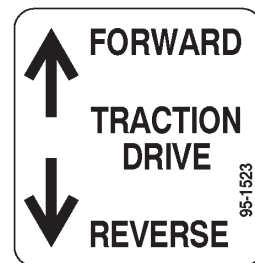

**ON FRAME NEXT TO HYDRO PUMPS
(Part No. 95-1543)**

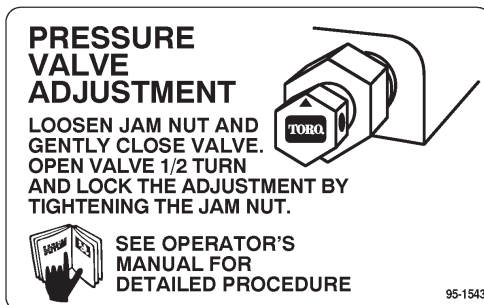

**ON UPPER HANDLE
(Part No. 82-4590)**



**ON OIL COOLER
(Part No. 54-0890)**



Gasoline and Oil

Recommended Gasoline

Use UNLEADED Regular Gasoline suitable for automotive use (85 pump octane minimum). Leaded regular gasoline may be used if unleaded regular is not available.

IMPORTANT: Never use methanol, gasoline containing methanol, or gasohol containing more than 10% ethanol because the fuel system could be damaged. Do not mix oil with gasoline.

DANGER

POTENTIAL HAZARD

- In certain conditions gasoline is extremely flammable and highly explosive.

WHAT CAN HAPPEN

- A fire or explosion from gasoline can burn you, others, and cause property damage.

HOW TO AVOID THE HAZARD

- Use a funnel and fill the fuel tank outdoors, in an open area, when the engine is cold. Wipe up any gasoline that spills.
- Do not fill the fuel tank completely full. Add gasoline to the fuel tank until the level is 1/4" to 1/2" (6 mm to 13 mm) below the bottom of the filler neck. This empty space in the tank allows gasoline to expand.
- Never smoke when handling gasoline, and stay away from an open flame or where gasoline fumes may be ignited by a spark.
- Store gasoline in an approved container and keep it out of the reach of children. Never buy more than a 30-day supply of gasoline.

DANGER

POTENTIAL HAZARD

- In certain conditions gasoline is extremely flammable and highly explosive.

WHAT CAN HAPPEN

- A fire or explosion from gasoline can burn you, others, and cause property damage.

HOW TO AVOID THE HAZARD

- Always place gasoline containers on the ground away from your vehicle before filling.
- Do not fill gasoline containers inside a vehicle or on a truck or trailer bed because interior carpets or plastic truck bed liners may insulate the container and slow the loss of any static charge.
- When practical, remove gas-powered equipment from the truck or trailer and refuel the equipment with its wheels on the ground.
- If this is not possible, then refuel such equipment on a truck or trailer from a portable container, rather than from a gasoline dispenser nozzle.
- If a gasoline dispenser nozzle must be used, keep the nozzle in contact with the rim of the fuel tank or container opening at all times until fueling is complete.

Using Stabilizer/Conditioner

Use a fuel stabilizer/conditioner in the machine to provide the following benefits:

- Keeps gasoline fresh during storage of 90 days or less. For longer storage it is recommended that the fuel tank be drained.
- Cleans the engine while it runs
- Eliminates gum-like varnish buildup in the fuel system, which causes hard starting

IMPORTANT: Do not use fuel additives containing methanol or ethanol.

Add the correct amount of gas stabilizer/conditioner to the gas.

Note: A fuel stabilizer/conditioner is most effective when mixed with fresh gasoline. To minimize the chance of varnish deposits in the fuel system, use fuel stabilizer at all times.

Filling the Fuel Tank

1. Shut the engine off.
2. Clean around the fuel tank cap and remove the cap. Use a funnel and add unleaded regular gasoline to the fuel tank, until the level is 1/4 to 1/2 inch (6 mm to 13 mm) below the bottom of the filler neck. This space in the tank allows gasoline to expand. Do not fill the fuel tank completely full.
3. Install the fuel tank cap securely. Wipe up any gasoline that may have spilled.

Check Engine Oil Level

Before you start the engine and use the machine, check the oil level in the engine crankcase; refer to *Checking Oil Level*, page 26.

Assembly

Loose Parts

Note: Use the chart below to verify all parts have been shipped.

DESCRIPTION	QTY.	USE
Wheel Nut	2 8	Install drive wheels
Upper handle Flanged bolt 3/8–16 x 1" (26 mm) Flange nut 3/8–16	1 4 4	Install upper handle to frame
Clevis pin Washer Hairpin cotter	1 1 2	Install control rods
Battery Battery holder Battery pad Bolt 3/8–16 x 1-3/4" (44 mm) Locknut 3/8–16 Battery strap Battery support rod Locknut 1/4–20 Carriage bolt 1/4–20 x 3/4" (19 mm) Nut 1/4–20 Terminal boot	1 2 2 2 2 1 2 2 2 2 2	Install battery
Flange bolt 1/2–13 x 1-1/4" (32 mm) Flange bolt 1/2–13 x 1-3/4" (44 mm)	4 2	Replace (6) 1/2–13 x 1" (26 mm) flange bolts supplied with mowers
Hydraulic filter	1	Use for initial hydraulic filter change
Operator's Manual Engine Operator's Manual Parts Catalog Registration card	1 1 1 1	Read before operating machine Fill out and return to Toro

Install Wheels

1. Mount wheels to wheel motor hubs with (8) lug nuts (Fig. 1). Torque bolts to 55 ft. lbs. (75 N·m).

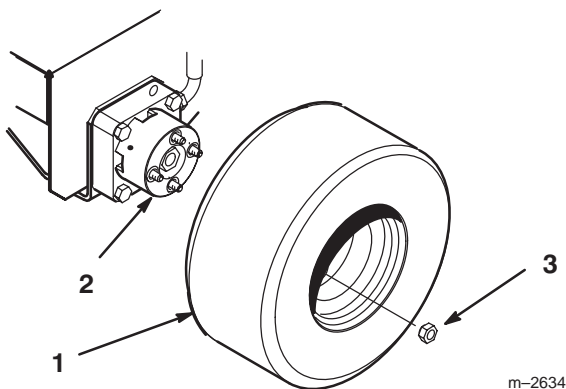

Figure 1

- | | |
|----------|------------|
| 1. Wheel | 3. Lug nut |
| 2. Hub | |

Install Upper Handle

1. Align upper handle with mounting holes in rear frame (Fig. 2). Select high, medium or low position for lower mounting hole.
2. Secure each side with (2) 3/8–16 x 1" (26mm) flange bolts and flange nuts (Fig. 2). Torque bolts to 25 ft. lbs. (34 N·m).

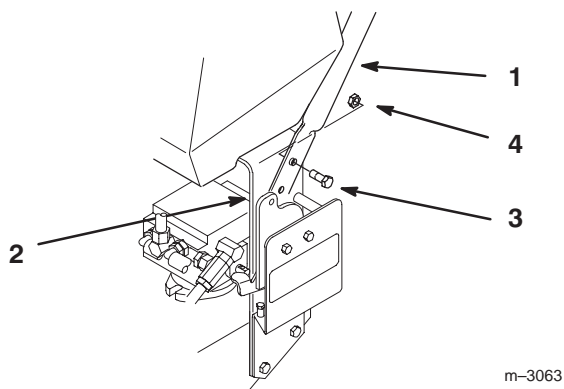

Figure 2

- | | |
|-----------------|-----------------------------------|
| 1. Upper handle | 3. Flange bolt 3/8–16 x 1" (26mm) |
| 2. Rear frame | 4. Flange nut 3/8" |

Install Control Rods

Before installing and adjusting control rods loosen quick release levers and move reference control bar all the way forward.

Left Control Rod

1. Slide clevis pin through rod fitting and mounting hole in control bracket (from outside). Secure with washer and hairpin cotter (Fig. 3).
2. Remove hairpin cotter and rod from upper control bars.
3. Press and hold upper control bars against reference bar, so stop hits.
4. Push rod full forward until bearing is against control bracket stop. Thread rod in or out of fitting on control bracket until rod aligns with holes in upper control bars (Fig. 3).
5. When rod and holes in upper control bars line up, turn rod one (1) additional turn, so rod is shorter.

Note: Upper control bar stop must hit reference bar before roller hits control bracket stop.

6. Connect rod to upper control bars with previously removed hairpin cotter.

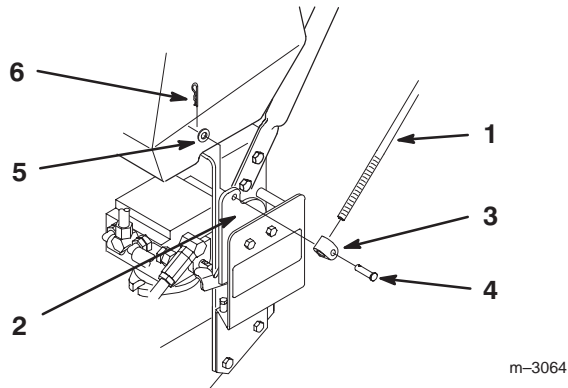

Figure 3

- | | |
|---------------------|-------------------|
| 1. Control rod-left | 4. Clevis pin |
| 2. Control bracket | 5. washer |
| 3. Rod fitting | 6. Hairpin cotter |

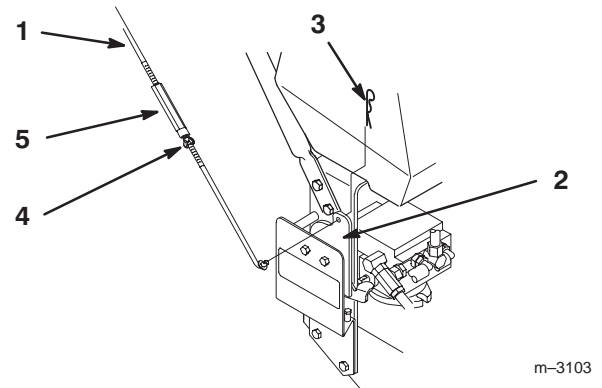

Figure 4

- | | |
|----------------------|---------------|
| 1. Control rod-right | 4. Wing nut |
| 2. Control bracket | 5. Turnbuckle |
| 3. Hairpin cotter | |

Right Control Rod

1. Slide rod into control bracket and secure with hairpin cotter (Fig. 4).
2. Remove hairpin cotter and rod from upper control bars.
3. Press and hold upper control bars against reference bar, so stop hits.
4. Push rod full forward until bearing is against control bracket stop. Loosen wing nut and thread turnbuckle in or out until rod aligns with holes in upper control bars (Fig. 3).
5. When rod and holes in upper control bars line up, rotate turnbuckle one (1) additional turn, so rod is shorter.

Note: Upper control bar stop must hit reference bar before roller hits control bracket stop.

6. Connect rod to upper control bars with previously removed hairpin cotter, tighten wing nut and turnbuckle.

Adjust Tracking

1. After completing assembly check machine tracking. Operate machine by holding upper control bar against reference bar with wheel drive engaged.
2. If machine does not track straight, moves more right or left, adjustment is required.
3. Loosen wing nut on right control rod and rotate turnbuckle in or out to change tracking. Secure turnbuckle in position with wing nut (Fig. 4).
4. Check for proper tracking.

Note: Control rods must be adjusted if handle height position is changed.

Activate the Battery

Bulk electrolyte with 1.260 specific gravity must be purchased from a local battery supply outlet.

1. Remove the battery from the machine.

IMPORTANT: Be careful not to damage the long vent tube when removing the battery.

DANGER

POTENTIAL HAZARD

- Battery electrolyte contains sulfuric acid which is a deadly poison and it causes severe burns.

WHAT CAN HAPPEN

- If you carelessly drink electrolyte you could die or if it gets onto your skin you will be burned.

HOW TO AVOID THE HAZARD

- Do not drink electrolyte and avoid contact with skin, eyes or clothing. Wear safety glasses to shield your eyes and rubber gloves to protect your hands.
- Fill the battery where clean water is always available for flushing the skin.
- Follow all instructions and comply with all safety messages on the electrolyte container.

2. Remove filler caps from the battery. Slowly pour electrolyte into each cell until the electrolyte level is up to the lower part of the tube (Fig. 5).

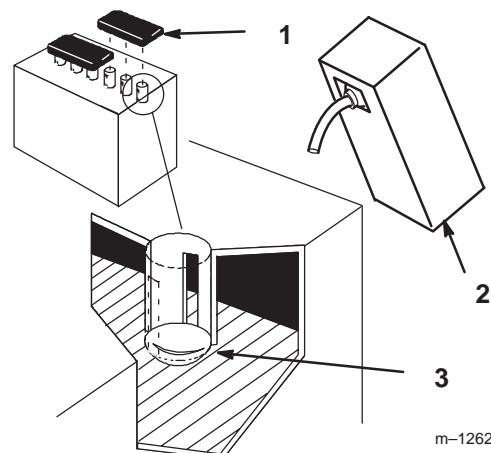

Figure 5

- | | |
|----------------|---------------------------|
| 1. Filler caps | 3. Lower part of the tube |
| 2. Electrolyte | |

3. Leave the covers off and connect a 3 to 4 amp battery charger to the battery posts (Fig. 6). Charge the battery at a rate of 4 amperes or less for 4 hours (12 volts).

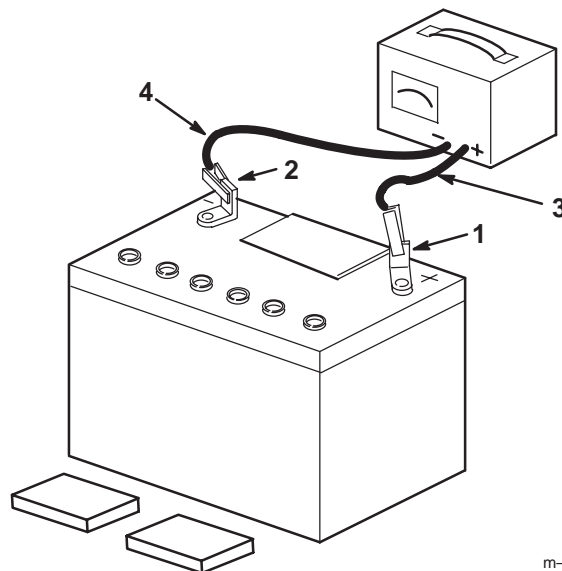

Figure 6

- | | |
|------------------|---------------------------|
| 1. Positive post | 3. Charger red (+) wire |
| 2. Negative post | 4. Charger black (-) wire |

WARNING

POTENTIAL HAZARD

- Charging battery produces gasses.

WHAT CAN HAPPEN

- Battery gasses can explode.

HOW TO AVOID THE HAZARD

- Keep cigarettes, sparks and flames away from battery.

4. When the battery is fully charged, disconnect the charger from the electrical outlet then from the negative and positive battery posts (Fig. 6).
5. Slowly pour electrolyte into each cell until the level is once again up to the "UPPER" line on the battery case (Fig. 5) and install covers.

Install Battery

1. Mount battery holder and cutting unit carrier frame at the same time to upper holes on right side of traction unit. Use (2) 1/2 x 1-3/4" (32 mm) flange head capscrews and (2) 1/2" locknuts (Fig. 7).
2. Fill battery with electrolyte and charge, refer to Battery, page 37.

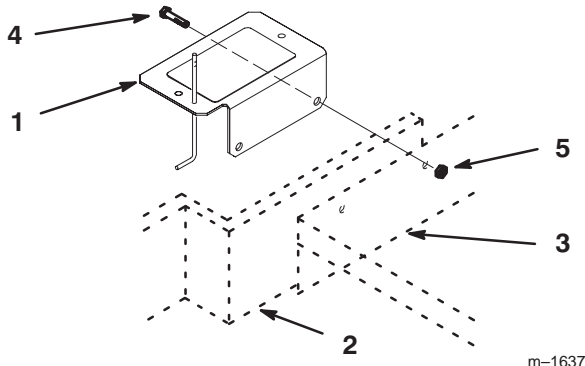

Figure 7

- | | |
|-------------------|---------------------------------|
| 1. Battery holder | 4. Bolt 1/2-13 x 1-3/4" (32 mm) |
| 2. Carrier frame | 5. Locknut 1/2" |
| 3. Traction frame | |

3. Position battery onto holder with terminal posts away from the engine (Fig. 8).
4. Slide the red terminal boot onto the red battery cable and the black terminal boot onto the the black battery cable.
5. Install the positive (red) battery cable to positive (+) battery terminal and the negative battery cable to the negative (-) battery terminal. Secure cables with (2) 1/4 x 3/4" (19 mm) carriage bolts and 1/4" nuts.
6. Mount battery to holder with (2) support rods, a battery clamp and (2) 1/4" locknuts. Position support rods in mounting holes (Fig. 8). Tighten locknuts so battery is held securely in position and will not slide. **Do not overtighten.**
7. Slide vent tube through hole, next to support rod, in battery holder.

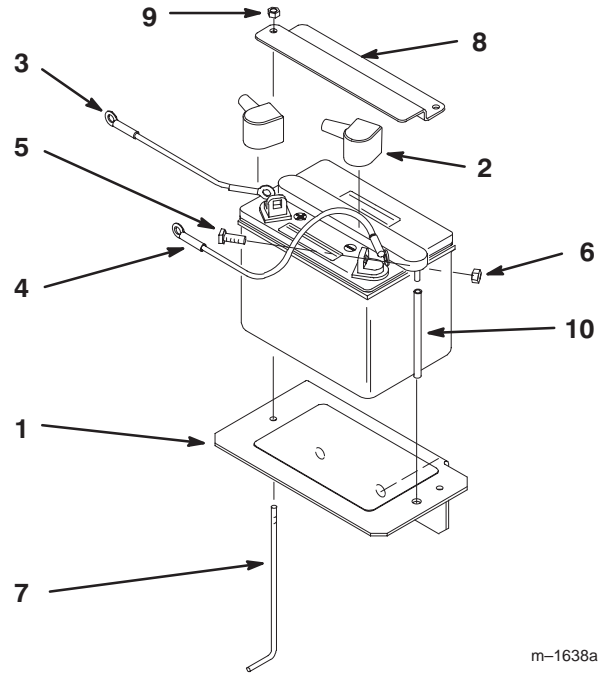

Figure 8

- | | |
|--|------------------------|
| 1. Battery holder | 6. Nut 1/4" |
| 2. Terminal boot | 7. Battery support rod |
| 3. Positive battery cable | 8. Battery clamp |
| 4. Negative battery cable | 9. Locknut 1/4" |
| 5. Carriage bolt 1/4-20 x 3/4" (19 mm) | 10. vent tube |

Operation

Think Safety First

Please carefully read all the safety instructions and symbols in the safety section. Knowing this information could help you, your family, pets or bystanders avoid injury.

Controls

Become familiar with all the controls (Fig. 9) before you start the engine and operate the machine.

Throttle Control – The throttle control has two positions: “FAST” and “SLOW”.

Choke Control – The choke control has two positions: “CHOKE” and “RUN”.

Blade Control Bail – Control bail used in conjunction with deck engagement switch (PTO) to release blade brake and engage clutch to drive mower blades. Release bail to disengage mower blades.

Blade Control Switch (PTO) – Rocker switch used in conjunction with control bail to release blade brake and engage clutch to drive mower blades.

Upper Control Bar – Push forward on control bar to engage forward traction operation, release to stop. Pull back on control bar to go backwards. Release either side of control bar to turn right or left.

Reference Handle – Limits forward travel of control bar to pre-set position to help maintain desired ground speed and direction of travel. It is locked in position with quick release levers.

Ignition Switch – Key switch is used with the electric starter. Switch has three positions: “START”, “RUN” and “OFF”.

Fuel Shut-off Valve – (Under fuel tank) Close fuel shut-off valve when transporting or storing mower.

Hour Meter – Shows total hours that machine has been operated. Only operates with ignition key in “ON” position.

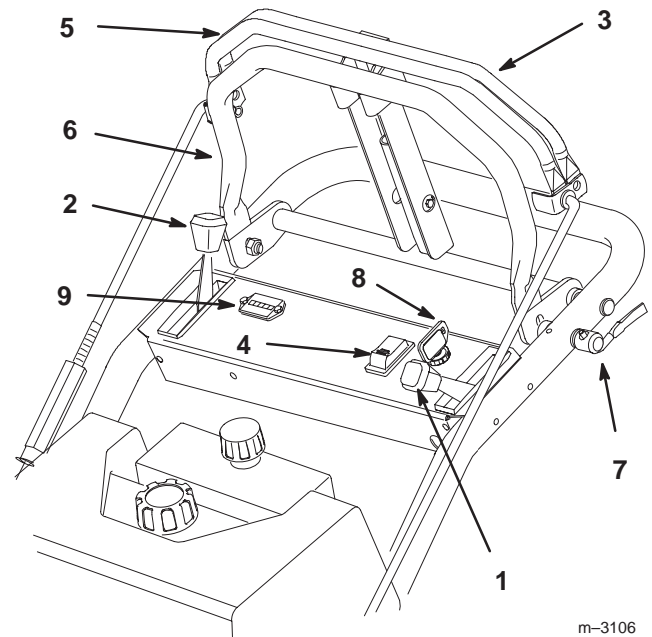

Figure 9

- | | |
|-------------------------------|------------------------|
| 1. Throttle control | 5. Upper control bar |
| 2. Choke control | 6. Reference handle |
| 3. Blade control bail | 7. Quick release lever |
| 4. Blade control switch (PTO) | 8. Ignition switch |
| | 9. Hourmeter |

Starting and Stopping the Engine

Starting

1. Make sure spark plug wire(s) are installed on spark plug(s) and fuel valve is open.
2. Move the choke control to “CHOKE” position before starting a cold engine.

Note: A warm or hot engine may require choking. After engine starts, move choke control to “RUN” position.
3. Move the throttle control to the “FAST” position before starting a cold engine.
4. Turn ignition key “START” to energize starter. When engine starts, release key.

IMPORTANT: Do not engage starter for more than 10 seconds at a time. If engine fails to start allow 30 second cool-down period between attempts. Failure to follow these instructions can burn out starter motor.

5. When engine starts move the choke control to “RUN” position.

Stopping

1. Move the throttle lever to “FAST” (Fig. 10).

Note: If the engine has been working hard or is hot, let it run for a minute before turning the ignition key “OFF.” This helps cool the engine before it is stopped. In an emergency, the engine may be stopped by turning the ignition key to “OFF.”

2. Turn the ignition key to “OFF” and remove the key (Fig. 10).

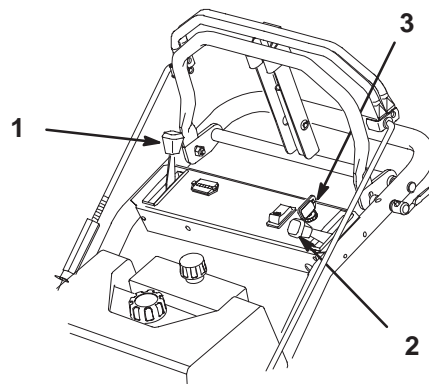

m-3106

Figure 10

- | | |
|-------------------|-----------------|
| 1. Choke lever | 3. Ignition key |
| 2. Throttle lever | |

3. Pull wire off spark plug(s) to prevent possibility of accidental starting before transporting or storing machine.
4. Close fuel shut off valve, under fuel tank, before transporting or storing machine.

IMPORTANT: Make sure fuel shut off valve is closed before transporting or storing machine, as fuel leakage may occur.

Operating Mower Blade Control (PTO)

The blade control switch (PTO) in conjunction with the blade control bail engages and disengages power to the electric clutch and mower blades.

Engaging the Mower Blades (PTO)

1. Release the upper control bar to stop the machine (Fig. 11).
2. To engage blade, squeeze blade control bail against upper control bar (Fig. 11).
3. Press blade control (PTO) rocker switch forward and release. Hold blade control bail against control bar while operating.
4. Repeat procedure to engage mower blades if blade control bail is released.

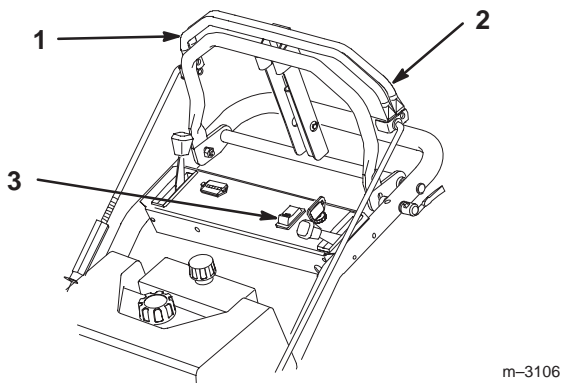

Figure 11

- | | |
|-----------------------|-------------------------------|
| 1. Upper control bar | 3. Blade control switch (PTO) |
| 2. Blade control bail | |

Disengaging the Mower Blades (PTO)

1. Releasing blade control bail to disengage blades (Fig. 11).

The Safety Interlock System

Understanding the Safety Interlock System

The safety interlock system is designed to prevent the mower from starting unless the control bar is in the neutral position and to prevent the blades from rotating when the blade control is released.

Testing the Safety Interlock System

Test the safety interlock system before you use the machine each time. If the safety system does not operate as described below, have an Authorized Service Dealer repair the safety system immediately.

1. Set the machine on a flat, open area.
2. Push the control bar full forward.
3. Rotate the ignition key to "START" and slowly move control bar back to neutral. Engine should not crank until control bar is within 5° of neutral position.
4. Start the engine: refer to Starting and Stopping the Engine, page 18. With engine running and control bar in neutral position, squeeze control bail against control bar (Do not press deck engagement switch), clutch should not engage and blades must not rotate.
5. Continue holding the blade control bail and press the rocker switch forward "ON" and release. The clutch should engage and the mower blades begin rotating.
6. Release the blade control bail. The clutch must disengage and the blades stop rotating.
7. Release the blade control bail (PTO), then push the blade control switch (PTO) to "ON" without holding the blade control bail. The clutch must not engage and the blades must not rotate.
8. If all the above conditions are not met have an Authorized Service Dealer repair the safety system immediately.

Driving Forward or Backward

The Enhanced T-Bar control system is designed to provide easy and comfortable operation of the hydrostatic drive. The control regulates ground speed, as well as forward, reverse and neutral functions, as well as steering direction.

The throttle control regulates the engine speed as measured in rpm (revolutions per minute). Place the throttle control in the “FAST” position for best performance.

Operate the machine with the engine speed set at slow or medium when learning how to use the controls. Practice driving the machine in a level open area.

Ground Speed

1. Place the quick release levers in the unlock position (Fig. 12).
2. Move the reference bar forward or backward to desired forward speed. The pointer indicates approximate ground speed (Fig. 12). When the bar is in the full forward position the ground speed is approximately 6 mph. When the bar is in the middle position the ground speed is approximately 3 mph.

Note: In normal conditions, a 2.5 to 3.0 mph ground speed (middle position of the reference bar) is best for cutting performance. Use a faster ground speed for light cutting or transport. Use a slower ground speed in heavy cutting loads.

3. Place the quick release levers in the lock position (Fig. 12).

Forward

1. To go forward, slowly press on the upper control bar against the reference bar (Fig. 12).
2. To go straight, apply equal pressure to both ends of the upper control bar (Fig. 12).
3. To turn, release pressure on the upper control bar side toward the direction you want to turn (Fig. 12).
4. To go straight, apply equal pressure to both sides of the upper control bar.
5. Adjust reference handle to maintain a comfortable pre-set ground speed (Fig. 12).
6. To stop, release the upper control bar to stop both wheels (Fig. 12).

Note: If the front of the deck lifts off the ground when the upper control bar is quickly pushed forward or the machine is unable to drive uphill, an adjustment may be needed. Refer to: Adjusting By-pass Valve.

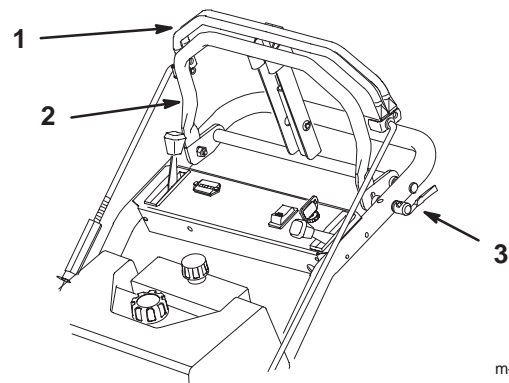

m-3106

Figure 12

1. Upper control bar
2. Reference control bar
3. Quick release lever

Backward

1. To go backward, slowly pull the control bar rearward (Fig. 12).
2. To go straight, apply equal pressure to both ends of the upper control bar (Fig. 12).
3. To turn, release pressure on the upper control bar side away from the direction you want to turn (Fig. 12).
4. To stop, release the upper control bar to stop both wheels (Fig. 12).

Neutral

Release the upper control bar to stop. The machine will automatically return to neutral. When in neutral, the hydrostatic drive system will provide dynamic braking so the machine will not roll.

Note: Very slow drive motion with engine running and the control in neutral is normal. Excessive drive motion when the control is in neutral may indicate adjustment is needed. Refer to: Adjusting Neutral procedure.

Stopping the Machine

1. To stop, release the upper control bar to stop both wheels (Fig. 12).
2. Release the blade control bail (PTO), to stop the mower blades. Move the engine speed throttle control to "FAST".
3. Turn the ignition key to "OFF" to stop the engine. Remember to remove the key from the ignition switch.

IMPORTANT: If the machine is on a slope, block the wheels to prevent the machine from slowly rolling.

IMPORTANT: If the machine will be left unattended, close the fuel shut off valve and disconnect the wire(s) from the spark plug(s).

CAUTION

POTENTIAL HAZARD

- Someone could move or attempt to operate the machine while it is unattended.

WHAT CAN HAPPEN

- Children or bystanders may be injured if they use the machine.

HOW TO AVOID THE HAZARD

- Always remove the ignition key and set the parking brake when leaving the machine unattended, even if just for a few minutes.

IMPORTANT: If the machine is loaded on a truck or trailer for transport, securely restrain the machine to prevent movement.

CAUTION

POTENTIAL HAZARD

- Stopping, starting and turning may cause the machine to move or shift position during transport.
- Rough roads may cause the machine to fall off vehicle or trailer during transport.

WHAT CAN HAPPEN

- Children or bystanders may be injured.
- The machine may be damaged.
- Other property may be damaged.

HOW TO AVOID THE HAZARD

- Always restrain the machine securely before transporting.

Pushing the Machine by Hand

The by-pass valve also allows the machine to be pushed by hand with the engine not running for easier servicing. If the by-pass valve is opened to push the machine by hand, adjustment is required for operation.

IMPORTANT: Always push the machine by hand. Never tow the machine because hydraulic damage may occur.

To Push the Machine

1. Disengage the power take off (PTO) and turn the ignition key to “OFF” to stop the engine.
2. Loosen jam nuts and rotate by-pass valves open 5 turns to push. This allows hydraulic fluid to by-pass the pump and the wheels to turn (Fig. 13).

IMPORTANT: Rotate by-pass valve a maximum of 5 turns so the valve does not come out of the body causing fluid to run out.

To Operate the Machine

If the by-pass valve is opened to push the machine by hand, adjustment is required for operation. Refer to: “Adjusting By-pass Valve”.

Note: The machine will not drive unless by-pass valves are properly adjusted.

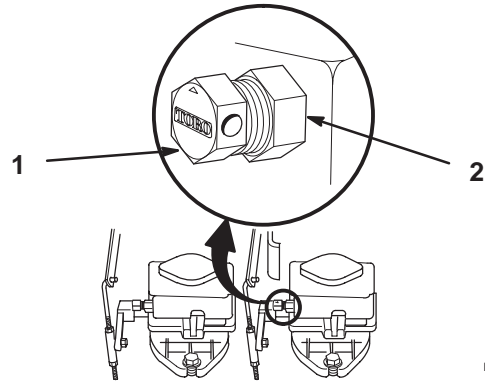

m-3098

Figure 13

1. By-pass valve

2. Jam nut

Maintenance

Service Interval Chart

Service Operation	Each Use	8 Hours	25 Hours	50 Hours	100 Hours	200 Hours	Storage Service
Hydraulic fluid—check level	Initial	X					X
Oil—check level	X						X
Oil—change*		Initial			X		X
Oil Filter—change (200 hours or every other oil change)						X	X
Hydraulic filter—change		Initial				X	X
Safety System—check	X						X
Foam Air Cleaner—service*			X				X
Paper Air Cleaner—replace*					X		X
Spark Plug(s)—check						X	X
Belts—check for wear/cracks				X			X
Electric Clutch—adjust					X		X
Gasoline—drain							X
Cooling systems—clean	X				X		X
Hydraulic lines—check					X		X
Battery—check electrolyte		X					X
Battery—charge, Disconnect cables							X
Fuel Filter—replace						X	X
Tires—check pressure				X			X
Chipped Surfaces—paint							X
* More often in dusty, dirty conditions							

CAUTION

POTENTIAL HAZARD

- If you leave the key in the ignition switch, someone could start the engine.

WHAT CAN HAPPEN

- Accidental starting of the engine could seriously injure you or other bystanders.

HOW TO AVOID THE HAZARD

- Remove the key from the ignition switch and pull the wire(s) off the spark plug(s) before you do any maintenance. Also push the wire(s) aside so it does not accidentally contact the spark plug(s).

Air Cleaner

Foam Element: Clean and re-oil after every 25 operating hours.

Paper Element: Replace after every 100 operating hours.

Note: Service the air cleaner more frequently (every few hours) if operating conditions are extremely dusty or sandy.

Removing the Foam and Paper Elements

1. Disengage the power take off (PTO) and turn the ignition key to "OFF" to stop the engine. Remove the key.
2. Clean around the air cleaner cover to prevent dirt from getting into the engine and causing damage (Fig. 14).
3. Carefully slide the foam element off the paper element (Fig. 14).
4. Unscrew the cover nut and remove the cover and paper element (Fig. 14).

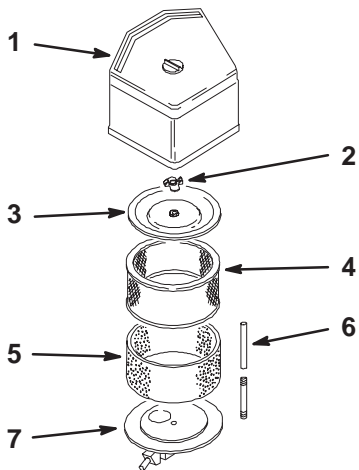

Figure 14

- | | |
|-------------------------------|---------------------|
| 1. Air cleaner cover and knob | 4. Foam element |
| 2. Wing nut | 5. Paper element |
| 3. Cover | 6. Rubber seal |
| | 7. Air cleaner base |

Cleaning the Foam and Paper Elements

1. Foam Element
 - A. Wash the foam element in liquid soap and warm water. When the element is clean, rinse it thoroughly.
 - B. Dry the element by squeezing it in a clean cloth.
 - C. Put one or two ounces of oil on the element (Fig. 15). Squeeze the element to distribute the oil.

IMPORTANT: Replace the foam element if it is torn or worn.

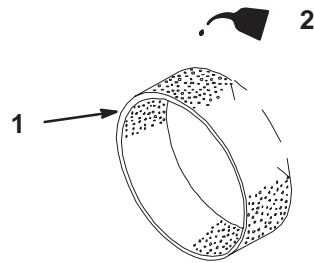

Figure 15

- | | |
|-----------------|--------|
| 1. Foam element | 2. Oil |
|-----------------|--------|

m-1213

m-1214

2. Paper Element

- A. Lightly tap the element on a flat surface to remove dust and dirt (Fig. 16).
- B. Inspect the element for tears, an oily film, and damage to the rubber seal.

IMPORTANT: Never clean the paper element with pressurized air or liquids, such as solvent, gas, or kerosene. Replace the paper element if it is damaged, defective, or cannot be cleaned thoroughly.

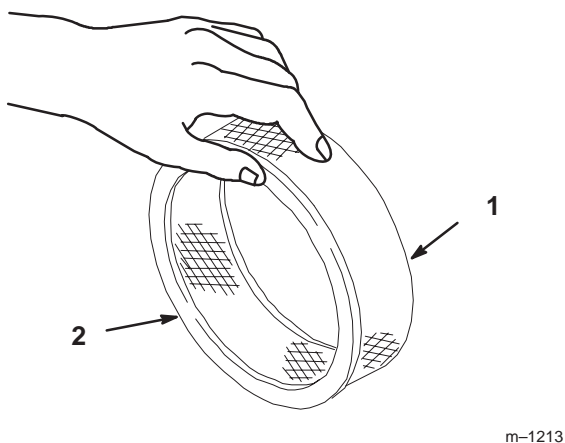

Figure 16

1. Paper element
2. Rubber seal

Engine Oil

Change oil:

- After the first 8 operating hours.
- After every 100 operating hours.

Note: Change oil more frequently when operating conditions are extremely dusty or sandy.

Oil Type: Detergent oil (API service SF, SG or SH)

Crankcase Capacity: w/filter, 2.1 qt. (2 l)

Viscosity: See table below

USE THESE SAE VISCOSITY OILS

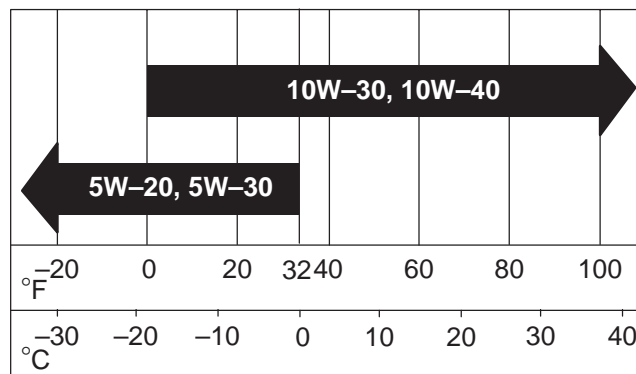

Installing the Foam and Paper Elements

1. Installing the Foam and Paper Elements

IMPORTANT: To prevent engine damage, always operate the engine with the complete foam and paper air cleaner assembly installed.

1. Carefully slide the foam element onto the paper air cleaner element (Fig. 14).
2. Place the air cleaner assembly onto the air cleaner base (Fig. 14).
3. Install the air cleaner cover and secure with cover nuts (Fig. 14).

Checking Oil Level

1. Park the machine on a level surface, disengage the power take off (PTO) and turn the ignition key to “OFF” to stop the engine. Remove the key.
2. Clean around the oil dipstick (Fig. 17) so dirt cannot fall into the filler hole and damage the engine.
3. Unscrew the oil dipstick and wipe the metal end clean (Fig. 17).
4. Slide the oil dipstick fully into the filler tube, do not thread onto tube (Fig. 17). Pull the dipstick out and look at the metal end. If oil level is low, slowly pour only enough oil into the filler tube to raise the level to the “FULL” mark.

IMPORTANT: Do not overfill the crankcase with oil because the engine may be damaged.

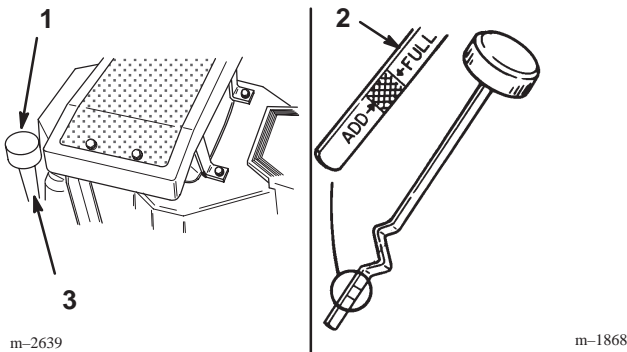

Figure 17

1. Oil dipstick
2. Metal end
3. Filler tube

Changing/Draining Oil

1. Start the engine and let it run five minutes. This warms the oil so it drains better.
2. Park the machine so that the drain side is slightly lower than the opposite side to assure the oil drains completely. Then disengage the power take off (PTO) and turn the ignition key to “OFF” to stop the engine. Remove the key.
3. Place a pan below the oil drain. Remove the oil drain cap (Fig. 18).
4. When oil has drained completely, install the oil drain cap.

Note: Dispose of the used oil at a certified recycling center.

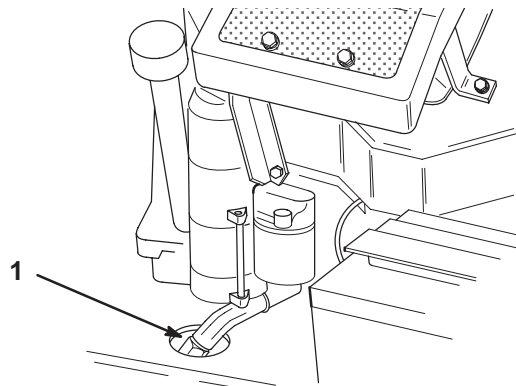

Figure 18

1. Oil drain cap

5. Slowly pour approximately 80% of the specified amount of oil specified, page 25, into the filler tube (Fig. 17). Now check the oil level; refer to Checking Oil Level, page 26. Slowly add additional oil to bring to “FULL” mark on dipstick.

Change Oil Filter

Replace the oil filter every 200 hours or every other oil change.

Note: Change oil filter more frequently when operating conditions are extremely dusty or sandy.

1. Drain the oil from the engine; refer to Changing/Draining Oil, page 26.
2. Remove the old filter and wipe the filter adapter (Fig. 19) gasket surface.
3. Apply a thin coat of new oil to the rubber gasket on the replacement filter (Fig. 19).

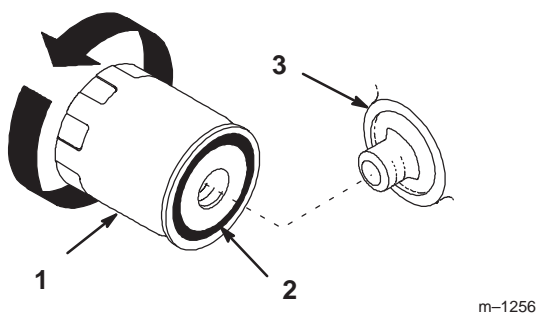

Figure 19

- | | |
|---------------|------------|
| 1. Oil filter | 3. Adapter |
| 2. Gasket | |

4. Install the replacement oil filter to the filter adapter. Turn the oil filter clockwise until the rubber gasket contacts the filter adapter, then tighten the filter an additional 1/2 turn (Fig. 19).
5. Fill the crankcase with the proper type of new oil; refer to Changing/Draining Oil, page 26.

Spark Plug

Check the spark plug(s) after every 200 operating hours. Make sure the air gap between the center and side electrodes is correct before installing the spark plug. Use a spark plug wrench for removing and installing the spark plug(s) and a gapping tool/feeler gauge to check and adjust the air gap. Install a new spark plug(s) if necessary.

Type: Champion RC12YC (or equivalent) Air Gap: 0.040 in. (1.02 mm)

Removing the Spark Plug(s)

1. Disengage the power take off (PTO), set the parking brake, and turn the ignition key to "OFF" to stop the engine. Remove the key.
2. Pull the wire(s) off the spark plug(s) (Fig. 20). Now clean around the spark plug(s) to prevent dirt from falling into the engine and potentially causing damage.
3. Remove the spark plug(s) and metal washer.

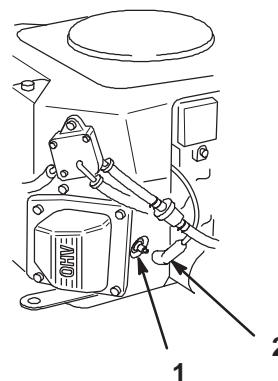

Figure 20

- | | |
|--------------------|---------------|
| 1. Spark plug wire | 2. Spark plug |
|--------------------|---------------|

Checking the Spark Plug

1. Look at the center of the spark plug(s) (Fig. 21). If you see light brown or gray on the insulator, the engine is operating properly. A black coating on the insulator usually means the air cleaner is dirty.

IMPORTANT: Never clean the spark plug(s). Always replace the spark plug(s) when it has: a black coating, worn electrodes, an oily film, or cracks.

2. Check the gap between the center and side electrodes (Fig. 21). Bend the side electrode (Fig. 21) if the gap is not correct.

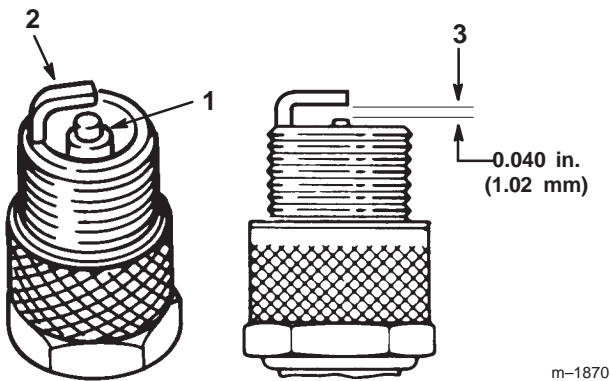

Figure 21

1. Center electrode insulator
2. Side electrode
3. Air gap (not to scale)

Installing the Spark Plug(s)

1. Install the spark plug(s) and metal washer. Make sure the air gap is set correctly.
2. Tighten the spark plug(s) to 20 ft-lb (27 N.m).
3. Push the wire(s) onto the spark plug(s) (Fig. 20).

Cleaning the Cooling Systems

Before each use, check and clean hydraulic and engine cooling systems. Remove any build-up of grass, dirt or other debris from the oil cooler screen and engine air intake. Every 100 hours clean oil cooler, engine cylinder and cylinder head cooling fins. Also clean around carburetor, governor levers and linkage. This will help insure adequate cooling to hydraulic pumps, motors and engine and will reduce the possibility of overheating and mechanical damage.

1. Remove oil cooler from the engine (Fig. 22). Save all mounting hardware.
2. Blow out fins of oil cooler and area between fins and screen with compressed air. If area between screen and fins is tightly packed, remove oil cooler from screen. Removing two retaining screws (Fig. 22). Save all mounting hardware.
3. Clean off engine air intake (Fig. 22).
4. Install oil cooler onto engine with previously removed hardware (Fig. 22).

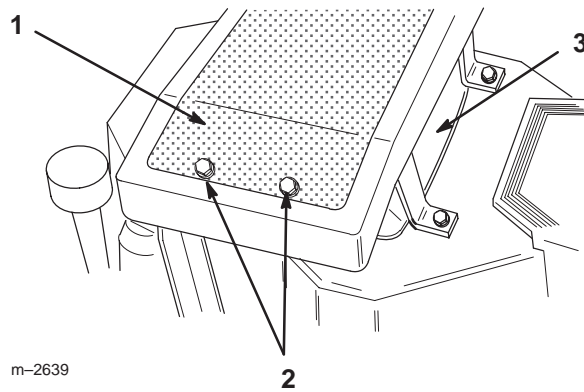

Figure 22

1. Oil cooler screen
2. Oil cooler retaining screw
3. Engine air intake

Tire Pressure

Maintain the air pressure in the front and rear tires as specified. Uneven tire pressure can cause uneven cut. Check the pressure at the valve stem after every 50 operating hours or monthly, whichever occurs first (Fig. 23). Check the tires when they are cold to get the most accurate pressure reading.

Pressure: 15 psi (.103 kPa) rear and castor tires

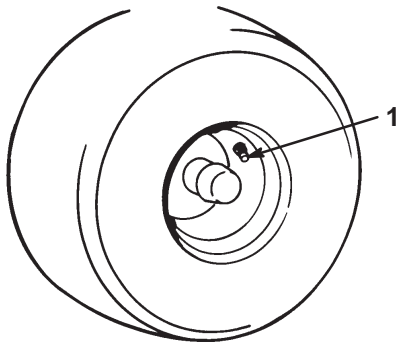

m-1872

Figure 23

1. Valve stem

Fuse

Service Interval/Specification

The electrical system is protected by a fuse. It requires no maintenance, however, if the fuse blows check component/circuit for malfunction or short. To replace fuse pull out on the fuse (Fig. 24) to remove or replace it.

Fuse: F1 Main-7.5 amp, blade-type
F2 Starter-30 amp, blade-type

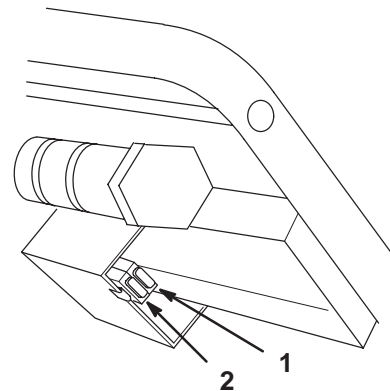

m-3100

Figure 24

1. Fuse 7.5 amp

2. Fuse 30 amp

Fuel Tank

DANGER

POTENTIAL HAZARD

- In certain conditions gasoline is extremely flammable and highly explosive.

WHAT CAN HAPPEN

- A fire or explosion from gasoline can burn you, others, and cause property damage.

HOW TO AVOID THE HAZARD

- Drain gasoline from the fuel tank when the engine is cold. Do this outdoors in an open area. Wipe up any gasoline that spills.
- Never drain gasoline near an open flame or where gasoline fumes may be ignited by a spark.
- Never smoke a cigarette, cigar or pipe.

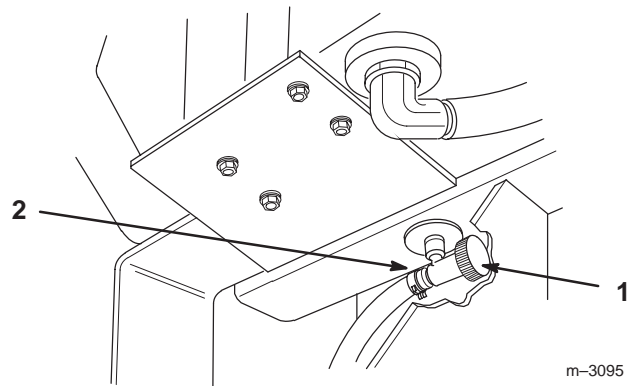

Figure 25

1. Fuel shut-off valve 2. Clamp

Draining The Fuel Tank

1. Park the machine on a level surface, to assure fuel tank drains completely. Then disengage the power take off (PTO) and turn the ignition key to "OFF" to stop the engine. Remove the key.
2. Close fuel shut-off valve at fuel tank (Fig. 25).
3. Squeeze the ends of the hose clamp together and slide it up the fuel line away from valve (Fig. 25).
4. Pull the fuel line off the valve (Fig. 25). Open fuel shut-off valve and allow gasoline to drain into a gas can or drain pan.

Note: Now is the best time to install a new fuel filter because the fuel tank is empty. Refer to Replacing the Fuel Filter; page 31.

5. Install the fuel line onto the valve. Slide the hose clamp close to the valve to secure the fuel line.

Fuel Filter

Replace the fuel filter after every 200 operating hours or yearly, whichever occurs first.

Replacing the Fuel Filter

Never install a dirty filter if it is removed from the fuel line.

1. Disengage the power take off (PTO) and turn the ignition key to "OFF" to stop the engine. Remove the key.
2. Close fuel shut-off valve at fuel tank (Fig. 25).
3. Squeeze the ends of the hose clamps together and slide them away from the filter (Fig. 26).
4. Remove the filter from the fuel lines.
5. Install a new filter and move the hose clamps close to the filter.
6. Open fuel shut-off valve at fuel tank (Fig. 25).

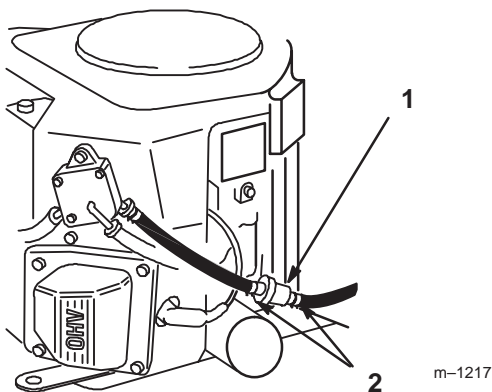

Figure 26

1. Hose clamp
2. Fuel line
3. Filter

Hydraulic System

Checking the Hydraulic Fluid

Check the hydraulic fluid level before engine is first started and after every 8 operating hours.

Fluid Type: Mobilube 424 (ISO 68) or equivalent anti-wear hydraulic fluid.

IMPORTANT: Use only hydraulic oils specified. Other fluids could cause system damage.

Tank Capacity: 1-3/4 qt. (1.6 l)

1. Position machine on a level surface and stop the engine.
2. Clean area around filler neck and cap/dipstick of hydraulic tank (Fig. 27).
3. Remove cap/dipstick from filler neck and wipe with a clean rag. Insert cap/dipstick and seat cap all the way into filler neck; then remove and check fluid level. Fluid level should be in between marks on dipstick.
4. If level is low, add fluid to raise level to full mark.
5. Install cap/dipstick onto filler neck.

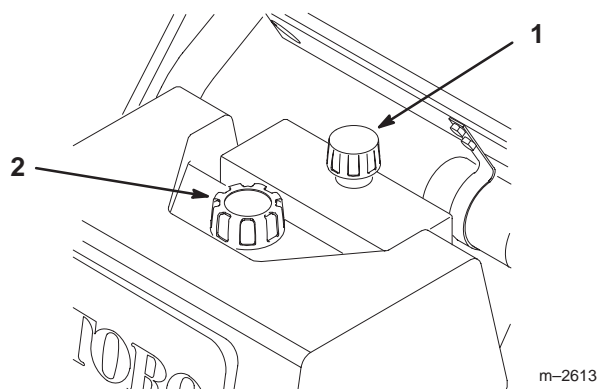

Figure 27

1. Hydraulic tank cap
2. Fuel tank cap/dipstick

Replacing the Hydraulic Filter

Change the hydraulic filter:

- After the first 8 operating hours.
 - After every 200 operating hours.
1. Position machine on a level surface, stop the engine, and remove key from ignition switch.

IMPORTANT: Do not substitute automotive oil filter or severe hydraulic system damage may result.

2. Place drain pan under filter, remove the old filter and wipe the filter adapter gasket surface (Fig. 28).

Note: Make sure fluid is completely drained before installing new filter.

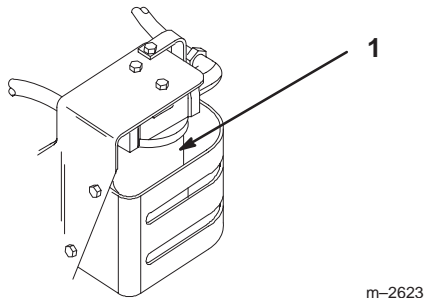

Figure 28

1. Hydraulic filter

3. Apply a thin coat of new oil to the rubber gasket on the replacement filter (Fig. 29).
4. Install replacement hydraulic filter onto the filter adapter. Turn the oil filter clockwise until the rubber gasket contacts the filter adapter, then tighten the filter an additional 1/2 turn (Fig. 29).
5. Start engine and let run for about two minutes to purge air from the system. Stop the engine and check for leaks. If one or both wheels will not drive, refer Bleeding Hydraulic System, page 32.

6. Check fluid level in hydraulic tank and add to raise level to FULL mark on dipstick. **Do not overfill.**

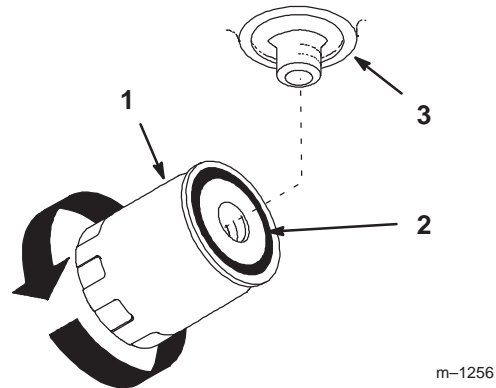

Figure 29

1. Hydraulic filter
2. Gasket
3. Adapter

Bleeding Hydraulic System

The traction system is self bleeding, however, it may be necessary to bleed the system if fluid is changed or after work is performed on the system.

1. Raise the rear of machine until wheels are off the floor and support with jack stands.
2. Start the engine and run at idle speed. Engage traction on one side and spin the wheel by hand.
3. When the wheel begins to spin on its own, keep it engaged until wheel drives smoothly. (minimum 2 minute)
4. Check hydraulic fluid level as it drops and add as required to maintain level.
5. Repeat procedure on opposite wheel.

Check Hydraulic Lines

After every 100 operating hours, check hydraulic lines and hoses for leaks, loose fittings, kinked lines, loose mounting supports, wear, weather and chemical deterioration. Make necessary repairs before operating.

WARNING

POTENTIAL HAZARD

- Hydraulic fluid escaping under pressure can penetrate skin and cause injury.

WHAT CAN HAPPEN

- Fluid accidentally injected into the skin must be surgically removed within a few hours by a doctor familiar with this form of injury or gangrene may result.

HOW TO AVOID THE HAZARD

- Keep body and hands away from pin hole leaks or nozzles that eject high pressure hydraulic fluid.
- Use cardboard or paper to find hydraulic leaks.

Adjusting By-pass Valve

The by-pass valve is adjustable to ensure easy operation with a variety of deck sizes. If the front of the deck lifts off the ground when the upper control bar is quickly pushed forward or the machine is unable to drive up hills, an adjustment may be needed.

Test Procedure

1. Start engine and run for 5 minutes at 3/4 throttle, to warm hydraulic fluid.
2. Drive the machine to a clear and level open area such as a driveway.

IMPORTANT: There should be at least 10 feet of clear area in front of the machine.

3. Loosen the quick release levers and push the reference bar forward to the “FAST” position. Lock the quick release levers to secure the reference bar.
4. Move throttle control to 3/4 throttle.
5. Quickly push the upper control bar against the reference bar. The front caster wheels should almost lift off the ground. If front caster wheels lift the off the ground , the machine is too aggressive and adjustment is required.
6. Move the engine throttle to the “FAST” position.
7. Quickly push the upper control bar against the reference bar. The front caster wheels should lift 1 to 3 inches off the ground. If front caster wheels lift the off the ground more than 3 inches, the machine is too aggressive. Adjustment is required.
8. If the machine accelerates slowly, and the front caster wheels do not lift off the ground, the machine is too un-responsive. Adjustment is required.

Adjustment Procedure

The by-pass valve should be adjusted to deliver best performance for the size (weight) mower you have. The by-pass valve factory setting is 1/2 turn out.

The following values can be used as initial settings for different size mowers:

- 62" 1/6 turn out
- 52" 1/2 turn out
- 44" 1 turn out
- 36" 1 turn out

9. Loosen large jam nut several turns (Fig. 30).
10. Gently close by-pass valve (Fig. 30).

IMPORTANT: Do not over-tighten valve or needle and seat may be damaged. Do not exceed 50 inch pounds to close valve.

11. Open by-pass valve 1/2 turn (Fig. 30).
12. Tighten jam nut to lock the adjustment (Fig. 30).
13. Repeat "Test Procedure" to check for proper operation.

IMPORTANT: By-pass valve adjustment is very sensitive, do not adjust more than 1/6 turn (one flat) at a time.

14. If the machine is too aggressive, the valve needs to be open further.
15. If the machine is un-responsive, the valve needs to be closed further.
16. Repeat "Test Procedure" to check for proper operation. Re-adjust the by-pass valves until proper performance is achieved.

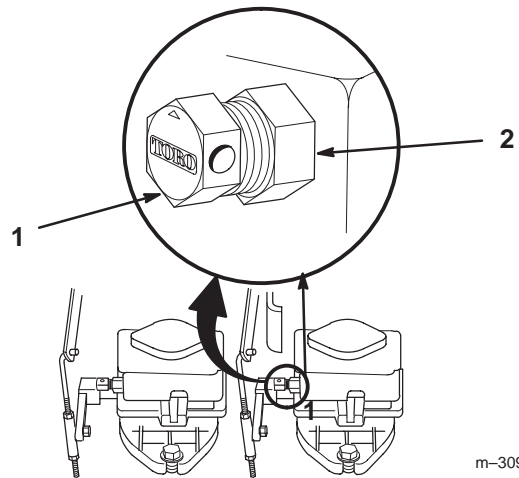

m-3098

Figure 30

1. By-pass valve
 2. Jam nut
-

Replacing the Traction Belt

Check traction drive belt for wear after every 50 hours of operation.

1. Raise the front of the machine and hold with jack stands.
2. Disconnect in-line wire connector from wire harness to electric clutch.
3. Remove mower drive belt; refer to mower Operator's Manual.
4. Remove left front engine mounting bolt securing clutch retainer to frame (Fig. 31). Unhook retainer from clutch and remove retainer.
5. Move idler pulley and remove traction belt from the drive pulleys and clutch.
6. Install new belt around clutch and drive pulleys.
7. Hook clutch retainer into clutch and secure to frame with engine mounting bolt. Torque engine mounting bolt to 170–220 in. lb. (19–24 N.m).
8. Connect clutch in-line wire connector to wire harness.

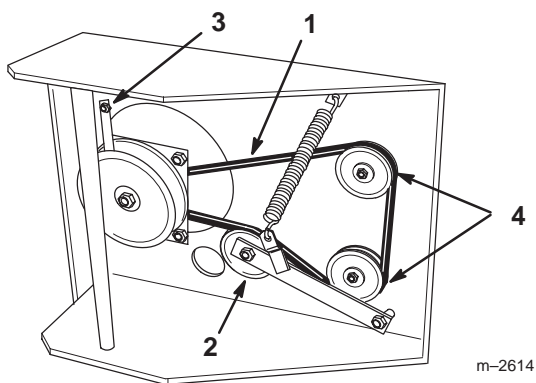

Figure 31

- | | |
|------------------|--------------------|
| 1. Traction belt | 3. Clutch retainer |
| 2. Idler pulley | 4. Drive pulley |

Adjusting the Electric Clutch

The clutch is adjustable to ensure proper engagement and proper braking. Check adjustment after every 100 hours of operation.

1. To adjust clutch, tighten or loosen lock nuts on flange studs (Fig. 32).
2. Check adjustment by inserting feeler gauge through slots next to studs (Fig. 32).
3. The proper disengaged clearance between the clutch plates is .012–.018 in. (0.30–0.45 mm). It will be necessary to check this clearance at each of the three slots to ensure the plates are parallel to each other.

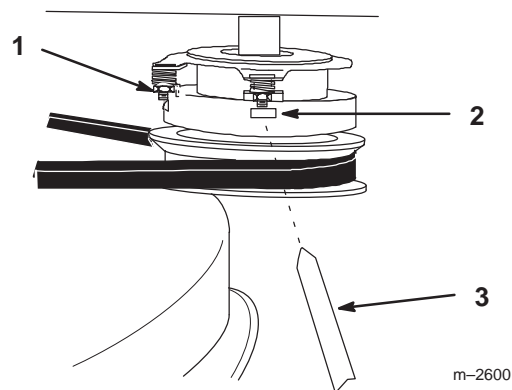

Figure 32

- | | |
|------------------|-----------------|
| 1. Adjusting nut | 3. Feeler gauge |
| 2. Slot | |

Adjusting Neutral

If wheels turn when control bar is in neutral, adjustment is required

1. Raise rear of the machine so wheels are off the ground and support with jack stands.

CAUTION

POTENTIAL HAZARD

- Someone could move or attempt to operate the machine while it is unattended.

WHAT CAN HAPPEN

- Children or bystanders may be injured if they use the machine.

HOW TO AVOID THE HAZARD

- Always remove the ignition key when leaving the machine unattended, even if just for a few minutes.

2. Start engine and run for 5 minutes at 3/4 throttle, to warm hydraulic fluid.
3. Move control bar rearward and forward then release. If wheels rotate when control bar is in neutral, adjustment is required.
4. Loosen top and bottom jam nuts at pump arm neutral adjustment sleeve (Fig. 33).
5. Push down on Pump Arm until Sleeve contacts bottom nut (Fig. 33). Wheel should now be rotating slowly in reverse.
6. Turn bottom nut up slowly, moving sleeve and pump arm up, until wheel stops rotating (Fig. 33).
7. Turn top nut down against sleeve and tighten to lock the adjustment (Fig. 33).
8. Repeat step 3 above to check adjustment. Repeat adjustment procedure if necessary.
9. Repeat on other wheel, if necessary.

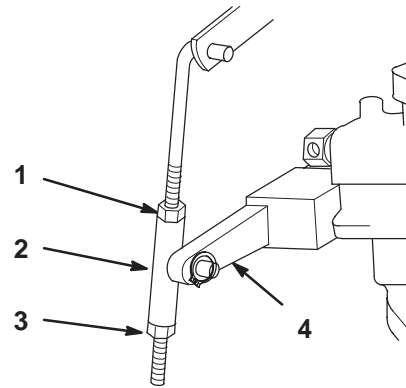

m-3071

Figure 33

- | | |
|----------------|-------------------|
| 1. Top jam nut | 3. Bottom jam nut |
| 2. Sleeve | 4. Pump arm |

Battery

Check the electrolyte level in the battery every eight (8) hours. Always keep the battery clean and fully charged. Use a paper towel to clean the battery case. If the battery terminals are corroded, clean them with a solution of four parts water and one part baking soda. Apply a light coating of grease to the battery terminals to prevent corrosion.

Voltage: 12 v, 280 Cold Cranking Amps

Checking Electrolyte Level

1. Open covers to see into the cells. The electrolyte must be up to the lower part of the tube (Fig. 34). Do not allow the electrolyte to get below the plates. (Fig. 34).
2. If the electrolyte is low, add the required amount of distilled water; refer to Adding Water to the Battery, page 37.

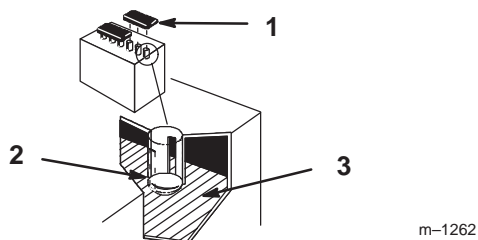

Figure 34

1. Filler caps
2. Lower part of tube
3. Plates

m-1262

Adding Water to the Battery

The best time to add distilled water to the battery is just before you operate the machine. This lets the water mix thoroughly with the electrolyte solution.

1. Clean the top of the battery with a paper towel.
2. Lift off the filler caps (Fig. 34).
3. Slowly pour distilled water into each battery cell until the level is up to the lower part of the tube (Fig. 34).

IMPORTANT: Do not overfill the battery because electrolyte (sulfuric acid) can cause severe corrosion and damage to the chassis.

4. Press the filler caps onto the battery.

Charging the Battery

IMPORTANT: Always keep the battery fully charged (1.260 specific gravity). This is especially important to prevent battery damage when the temperature is below 32°F (0°C).

1. Check the electrolyte level; refer to Checking Electrolyte Level, page 37.
2. Remove the filler caps from the battery and connect a 3 to 4 amp battery charger to the battery posts. Charge the battery at a rate of 4 amperes or less for 4 hours (12 volts). Do not overcharge the battery. Install the filler caps after the battery is fully charged.

WARNING

POTENTIAL HAZARD

- Charging the battery produces gasses.

WHAT CAN HAPPEN

- Battery gasses can explode.

HOW TO AVOID THE HAZARD

- Keep cigarettes, sparks and flames away from battery.

Wiring Diagram

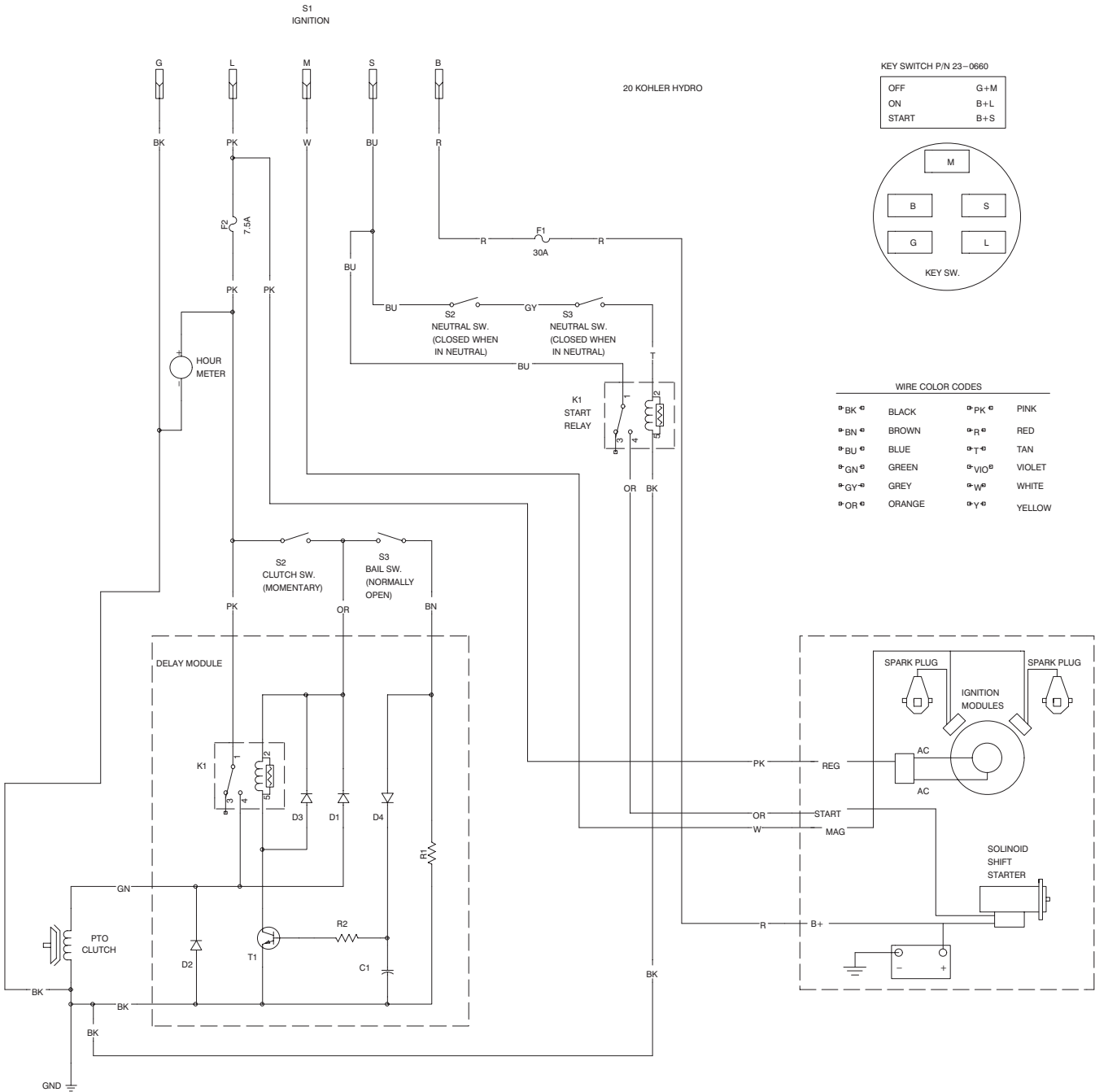

Hydraulic Diagram

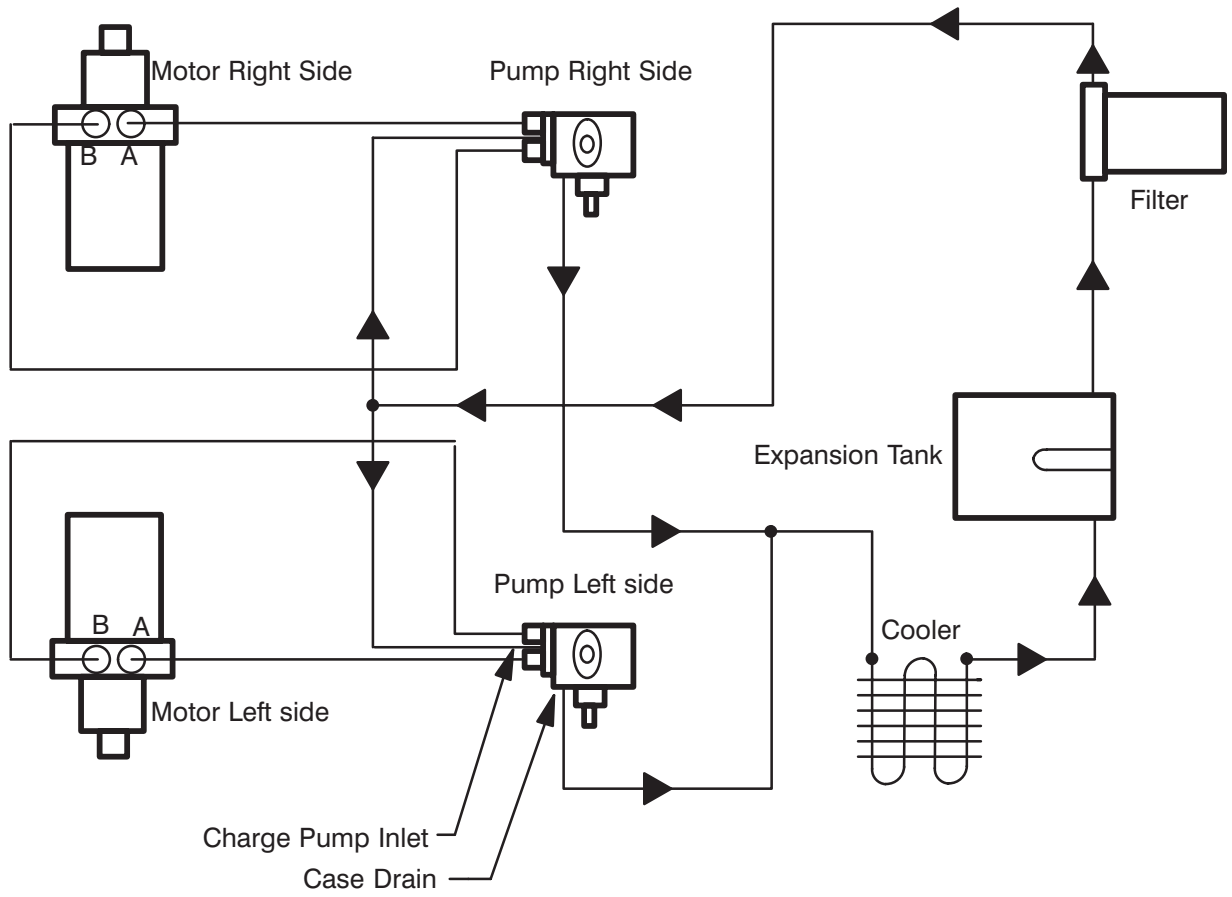

Cleaning and Storage

1. Disengage the power take off (PTO) and turn the ignition key to “OFF” to stop the engine. Remove the key.
2. Remove grass clippings, dirt, and grime from the external parts of the entire machine, especially the engine. Clean dirt and chaff from the outside of the engine’s cylinder head fins and blower housing.

IMPORTANT: You can wash the machine with mild detergent and water. Do not pressure wash the machine. Avoid excessive use of water, especially near the control panel, engine, hydraulic pumps and motors.

3. Service the air cleaner; refer to Air Cleaner, page 24.
4. Change the crankcase oil; refer to Engine Oil, page 25.
5. Change the hydraulic fluid; refer to Hydraulic System, page 31.
6. Remove the spark plug(s) and check its condition; refer to Spark Plug, page 27. With the spark plug(s) removed from the engine, pour two tablespoons of engine oil into the spark plug hole. Now use the starter to crank the engine and distribute the oil inside the cylinder. Install the spark plug(s). Do not install the wire on the spark plug(s).
7. Check the tire pressure; refer to Tire Pressure, page 29.

8. For storage over 30 days, prepare the traction unit as follows.
 - A. Add a petroleum based stabilizer/conditioner to fuel in the tank. Follow mixing instructions from stabilizer manufacturer. (1 oz. per gallon). **Do not use an alcohol based stabilizer (ethanol or methanol).**

Note: A fuel stabilizer/conditioner is most effective when mixed with fresh gasoline and used at all times.

- B. Run the engine to distribute conditioned fuel through the fuel system (5 minutes).
- C. Stop the engine, allow it to cool and drain the fuel tank; refer to Draining Fuel Tank, page 30.
- D. Restart the engine and run it until it stops.
- E. Choke or prime the engine.
- F. Start and run the engine until it will not start again. Use the primer, if equipped on machine, several times to ensure no fuel remains in primer system.
- G. Dispose of fuel properly. Recycle as per local codes.

IMPORTANT: Do not store stabilizer/conditioned gasoline over 90 days.

9. Check and tighten all bolts, nuts, and screws. Repair or replace any part that is damaged or defective.
10. Paint all scratched or bare metal surfaces. Paint is available from your Authorized Service Dealer.
11. Store the machine in a clean, dry garage or storage area. Remove the key from the ignition switch and keep it in a memorable place. Cover the machine to protect it and keep it clean.

Troubleshooting

PROBLEM	POSSIBLE CAUSES	CORRECTIVE ACTION
Engine will not start, starts hard, or fails to keep running.	<ol style="list-style-type: none"> 1. Fuel tank is empty. 2. Choke is not ON. 3. Air cleaner is dirty. 4. Spark plug wire is loose or disconnected. 5. Spark plug is pitted, fouled, or gap is incorrect. 6. Dirt in fuel filter. 7. Dirt, water, or stale fuel is in fuel system. 8. Battery is dead. 	<ol style="list-style-type: none"> 1. Fill fuel tank with gasoline. 2. Move choke lever to ON. 3. Clean or replace air cleaner element. 4. Install wire on spark plug. 5. Install new, correctly gapped spark plug. 6. Replace fuel filter. 7. Contact Authorized Service Dealer. 8. Charge battery.
Engine loses power.	<ol style="list-style-type: none"> 1. Engine load is excessive. 2. Air cleaner is dirty. 3. Oil level in crankcase is low. 4. Cooling fins and air passages under engine blower housing are plugged. 5. Spark plug is pitted, fouled, or gap is incorrect. 6. Vent hole in fuel cap is plugged. 7. Dirt in fuel filter. 8. Dirt, water, or stale fuel is in fuel system. 	<ol style="list-style-type: none"> 1. Reduce ground speed. 2. Clean air cleaner element. 3. Add oil to crankcase. 4. Remove obstruction from cooling fins and air passages. 5. Install new, correctly gapped spark plug. 6. Clean or replace the fuel cap. 7. Replace fuel filter. 8. Contact Authorized Service Dealer.
Engine overheats.	<ol style="list-style-type: none"> 1. Engine load is excessive. 2. Oil level in crankcase is low. 3. Cooling fins and air passages under engine blower housing are plugged. 	<ol style="list-style-type: none"> 1. Reduce ground speed. 2. Add oil to crankcase. 3. Remove obstruction from cooling fins and air passages.
Abnormal vibration.	<ol style="list-style-type: none"> 1. Engine mounting bolts are loose. 2. Loose engine pulley, idler pulley, or blade pulley. 3. Engine pulley is damaged. 	<ol style="list-style-type: none"> 1. Tighten engine mounting bolts. 2. Tighten the appropriate pulley. 3. Contact Authorized Service Dealer.

PROBLEM	POSSIBLE CAUSES	CORRECTIVE ACTION
Machine does not drive.	<ol style="list-style-type: none"> 1. Hydrostatic fluid level low. 2. Traction belt is worn, loose or broken. 3. Traction belt is off pulley. 	<ol style="list-style-type: none"> 1. Fill hydrostatic fluid tank. 2. Change Belt. 3. Change Belt.
Machine does not drive up hills or inclines.	<ol style="list-style-type: none"> 1. By-pass valve is adjusted too far open. 	<ol style="list-style-type: none"> 1. Adjust by-pass valve
Machine moves slowly in neutral.	<ol style="list-style-type: none"> 1. Neutral is mis-adjusted. 2. Return spring is broken or missing. 3. Linkage is dirty or bent. 	<ol style="list-style-type: none"> 1. Adjust hydro pump neutral. 2. Replace return spring. 3. Clean and lubricate linkage. Replace bent or worn parts.
Machine drive is too aggressive. Mower lifts when drive is engaged.	<ol style="list-style-type: none"> 1. By-pass valve is adjusted too far closed. 	<ol style="list-style-type: none"> 1. Adjust by-pass valve



THE TORO TOTAL COVERAGE GUARANTEE

A One-Year Limited Warranty (A Two-Year Full Warranty for Residential Use)

What Is Covered By This Express Warranty?

The Toro Company promises to repair any TORO Product used for commercial, institutional, or rental purposes if defective in materials or workmanship. The following time frames apply from the date of purchase:

<u>Product</u>	<u>Warranty Period</u>
All Products	1 year
All Spindles	2 years parts & labor, 3rd year parts only
Engines on the following:	2 years
Out Front and MidMount Zero Radius Tractors	
ProLine Mid-size Mowers	
Groundsmaster Riding Mowers	
ProLine Hand Held Gas Products (AE & LE engines only)	
Backpack Blowers	

The cost of parts and labor are included, but the customer pays the transportation cost. Transportation within a 15-mile radius of a TORO ProLine Service Dealer is covered under this warranty for Riding Products, Midsize Mowers and Turf Maintenance Equipment.

What Products Are Covered By This Warranty?

- Z-Master Zero Radius Tractors
- ProLine Mid-size Mowers
- Groundsmaster Riding Mowers
- ProLine Hand-held Gas Products
- Backpack Blowers
- Turf Maintenance Equipment
- Debris Management Equipment

How About Residential Use?

TORO Products used for residential use are covered by a full two-year warranty.

How Do You Get Warranty Service?

Should you feel your TORO Product contains a defect in materials or workmanship, contact the dealer who sold you the product or any TORO ProLine Service Dealer. The Yellow Pages of your telephone directory is a good reference source; look under TORO Commercial Service Dealers. The Service Dealer will either arrange service at his/her dealership or recommend another authorized Service Dealer who may be more convenient. You may need proof of purchase (copy of registration card, sales receipt, etc.) for warranty validation.

If for any reason you are dissatisfied with a Service Dealer's analysis of the defect in materials or workmanship or if you need a referral to a TORO ProLine Service Dealer, please feel free to contact us at the following address:

Toro Customer Service Department
8111 Lyndale Avenue South
Bloomington, MN 55420-1196
612-888-8801 or 800-348-2424

What Must You Do To Keep The Warranty In Effect?

You must maintain your TORO Product by following the maintenance procedures described in the operator's manual. Such routine maintenance, whether performed by a dealer or by you, is at your expense.

What Does This Warranty Not Cover? and

How Does Your State Law Relate To This Warranty?

There is no other express warranty except for special emission system coverage on some products and as described above. This express warranty does not cover:

- Cost of regular maintenance service or parts, such as filters, fuel, lubricants, tune-up parts, blade sharpening, brake and clutch adjustments.
- Any product or part which has been altered or misused or required replacement or repair due to normal wear, accidents, or lack of proper maintenance.
- Repairs necessary due to improper fuel, contaminants in the fuel system, or failure to properly prepare the fuel system prior to any period of non-use over three months.
- Pickup and delivery charges for distances beyond a 15-mile radius from a TORO ProLine Service Dealer.

All repairs covered by this warranty must be performed by a TORO Service Dealer using Toro approved replacement parts.

The Toro Company is not liable for indirect or consequential damages in connection with the use of the TORO Products covered by this warranty, including any cost or expense of providing substitute equipment or service during reasonable periods of malfunction or non-use pending completion of repairs under this warranty. Some states do not allow exclusions of incidental or consequential damages, so the above exclusion may not apply to you.

This warranty gives you specific legal rights, and you may also have other rights which vary from state to state.

COUNTRIES OTHER THAN THE UNITED STATES OR CANADA

Customers who have purchased TORO products exported from the United States or Canada should contact their TORO Distributor (Dealer) to obtain guarantee policies for your country, province, or state. If for any reason you are dissatisfied with your Distributor's service or have difficulty obtaining guarantee information, contact the TORO importer. If all other remedies fail, you may contact us at The Toro Company.