



Dingo[®] 320–D

Compact Utility Loader

Model No. 22303TE—210000001 and Up

Parts Catalog

Ordering Replacement Parts

To order replacement parts, please supply: the part number, the quantity, and the description of each part desired.

Understanding Reference Numbers

Each identified part in an illustration has a reference number. The reference number for a part also appears in the parts list, along with other information about the part.

This catalog uses two special reference number formats, one to indicate parts in a service assembly and another to indicate the quantity of a given part in an illustration.

Service Assembly Reference Numbers

Parts in service assemblies have reference numbers in the form **a:b**. The **a** represents the reference number of the entire service assembly and the **b** represents a sequential number unique to each part within the service assembly.

For example, a wheel assembly might be identified by reference number **6**, the tire by **6:1**, the valve by **6:2**, and the wheel by **6:3**. When you order the assembly identified by reference number **6**, you receive all parts identified by reference numbers **6:1**, **6:2**, and **6:3**. However, you may also order any part individually.

Reference numbers of this type appear in illustrations and in part lists.

Reference Numbers Indicating Quantity

In an illustration, if a reference number indicates more than one part, the reference number has the form **nX y**. The **n** represents the quantity of the part, the **X** is the multiplication symbol, and the **y** represents the reference number.

For example, in an illustration, the reference number **2X 37** means that two of the parts identified by reference number **37** are indicated.

Contents

Description	Page	Description	Page
Frame and Loader Arm Assembly	4	Gear Case Assembly	33
Hood and Screen Assembly	5	Head Cover Assembly	34
Wheel and Motor Assembly	6	Dipstick and Guide Assembly	35
One Line Title	7	Main Bearing Case Assembly	36
Engine Assembly	8	Camshaft Assembly	37
Engine Mount Assembly	9	Piston and Crankshaft Assembly	38
Fuel Tank and Air Filter Assembly	10	Flywheel Assembly	39
Air Cleaner Assembly No. 99–3160	11	Fuel Camshaft Assembly	40
Radiator Mount Assembly	12	Engine Stop Lever Assembly	41
Hydraulic Tank and Filter Assembly	13	Injection Pump Assembly	42
Auxiliary Control Lever Assembly	14	Injection Pump (Complete Parts)	43
Hydraulic Valve Assembly	15	Governor Assembly	44
One Line Title	16	Speed Control Plate Assembly	45
One Line Title	17	Nozzle Holder and Glow Plugs Assembly	46
One Line Title	18	Nozzle Holder (Complete Parts)	47
4–Spool Valve Assembly	19	Fuel Pump (Mechanical)	49
One Line Title	20	Dynamo and Pulley Assembly	50
Hydraulic Motor Assembly	21	Dynamo (Complete Parts)	51
Hydraulic Cylinder Assembly	22	Starter Assembly	52
One Line Title	23	Starter (Complete Parts)	53
Parking Brake Assembly	24	Oil Switch and Thermoswitch Assembly	54
Rear Cover Assembly	25	Water Flange and Thermostat Assembly	55
Battery Mount Assembly	26	Water Pump Assembly	56
Electrical Components Assembly	27	Water Pipe Assembly	57
Electrical Schematic	28	Valve and Rocker Arm Assembly	58
Hydraulic Schematic	29	Inlet Manifold Assembly	59
Crankcase Assembly	30	Exhaust Manifold Assembly	60
Oil Pan Assembly	31	Gasket Kit	61
Cylinder Head Assembly	32		

Part Description Abbreviations

Part descriptions in this catalog may include the following abbreviations.

Abbreviation	Meaning	Abbreviation	Meaning
AR	as required	HYD	hydraulic
ASM	assembly	INC	incorporated
CARR	carriage	LH	left hand
DEG	degrees	NI	nylon insert
FH	flat head	PPH	Phillips pan head
GA	gauge	PTH	Phillips truss head
HF	hex flange	PTO	power take off
HH	hex head	RH	right hand
HHF	hex head flange	SFH	slotted fillister head
HLH	hex lag head	SHH	slotted hex head
HJ	hex jam	SQH	square head
HOC	height-of-cut	SHWH	slotted hex washer head
HS	hex socket	SPH	slotted pan head
HSBH	hex socket button head	SRH	slotted round head
HSFH	hex socket flat head	STD	standard
HSH	hex socket head	TAP	self tapping
HWH	hex washer head	TTH	Torx truss head
HWHTF	hex washer head thread forming	WH	wing head

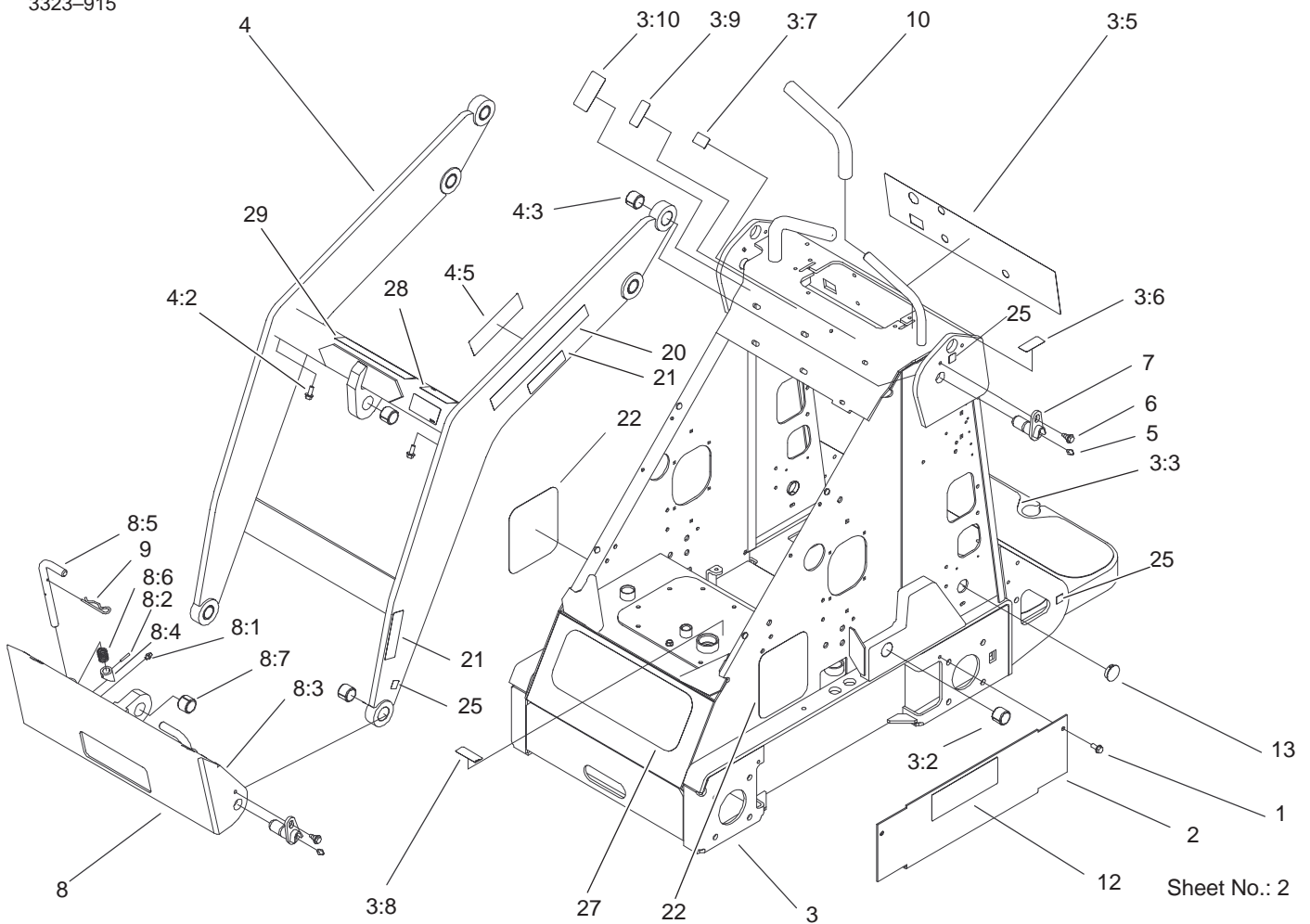

Sheet No.: 2

Frame and Loader Arm Assembly

Ref. No.	Part No.	Qty.	Description
1	32144-70	6	Screw-HH
2	99-3020-01	2	Cover-Hose
3	104-7416	1	Frame ASM
3:2	98-4871	2	Bushing-Tension
3:3	98-9947	2	Tread-Foot
3:5	100-1706	1	Decal-Panel, Control
3:6	98-8219	1	Decal-Throttle
3:7	100-1703	1	Decal-Limiter, Speed
3:8	93-6686	1	Decal-Oil, Hydraulic
3:9	98-8235	1	Decal-Selector
3:10	100-1704	1	Decal-Power, Auxiliary
4	100-8814	1	Loader ASM
4:2	32144-70	2	Screw-HH
4:3	98-4871	7	Bushing-Tension
4:5	100-1701	1	Decal-Danger
5	302-5	4	Fitting-Grease
6	99-5105	4	Bolt-Shoulder
7	99-1414	4	Pin-Pivot
8	98-4690	1	Quick Attach ASM
8:1	302-5	2	Fitting-Grease
8:2	32121-94	2	Pin-Special
8:3	98-4691-03	1	Mount-Attach, Quick
8:4	98-4692	2	Cam-Attach, Quick
8:5	100-3373	2	Pin
8:6	98-4694	2	Spring-Compression

Ref. No.	Part No.	Qty.	Description
8:7	98-4871	1	Bushing-Tension
9	3290-468	2	Pin-Cotter
10	98-4845	2	Grip-Cushion
12	99-3068	2	Decal-4-Paw
13	94-1402	2	Plug-Hole
20	99-3167	2	Decal-Dingo 320d
21	100-8821	4	Decal-Pinch
22	100-8827	2	Decal-Dingo, Side
25	93-9084	6	Decal-Point, Lift
27	100-8828	1	Decal-Dingo, Front
28	100-8822	2	Decal-No Rider
29	100-1702	1	Decal-Caution

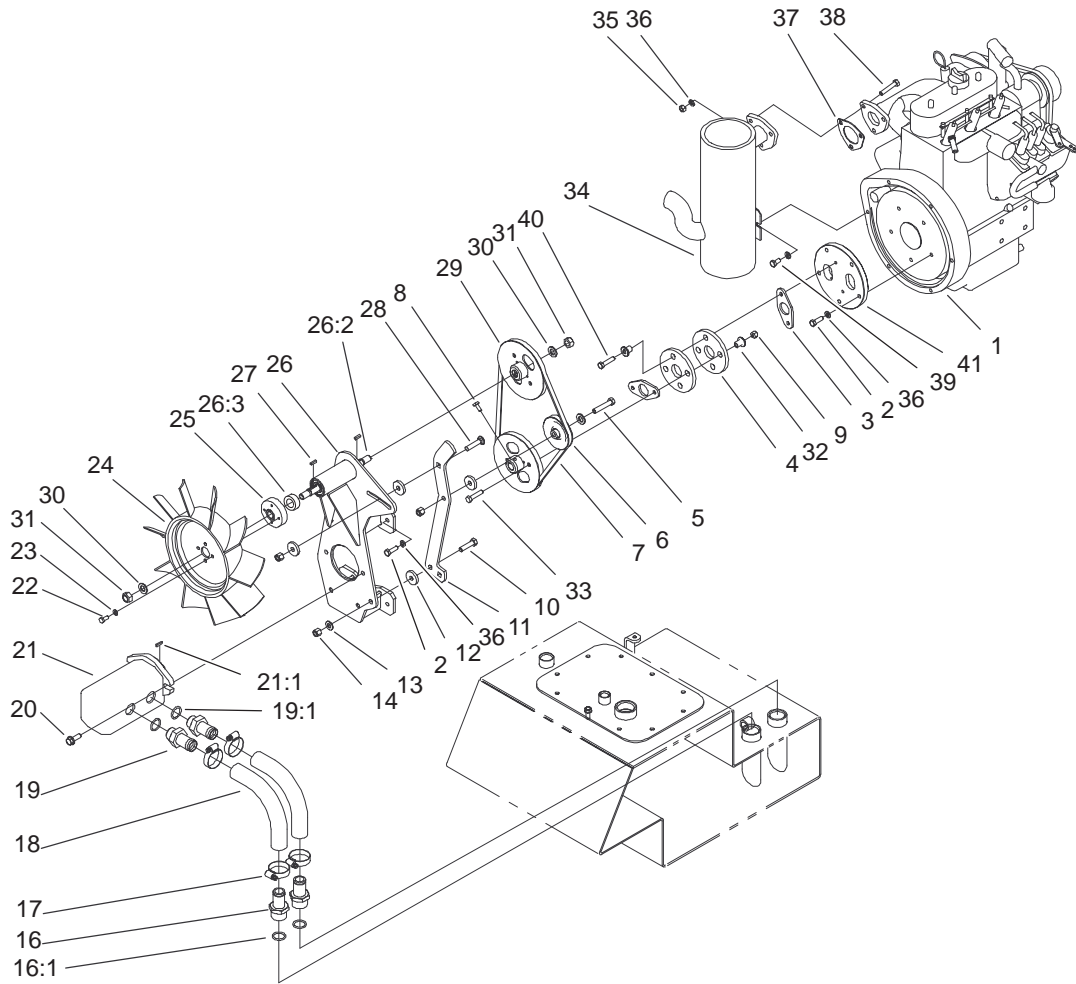

Sheet No.: 5

Engine Assembly

Ref. No.	Part No.	Qty.	Description
1		1	Engine-D722-E, Kubota
2	99-5131	9	Bolt
3	99-1430	1	Spacer-Coupler
4	44-2230	2	Coupling-Rubber
5	323-10	1	Screw-HH
6	63-8140	1	Pulley-Idler
7	92-8876	1	V-Belt
8	3241-5	2	Screw-Set
9	104-9469	2	Nut-Lock
10	323-8	1	Screw-HH
11	100-1727-01	1	Mount-Tensioner
12	99-5121	4	Spacer
13	3256-24	2	Washer-Flat
14	3296-39	3	Nut-Lock, NI
16	354-78	2	Connector-Hose
16:1	237-146	1	O-Ring
17	2412-111	4	Clamp
18	99-3046	2	Hose-Suction, Formed
19	99-3017	2	Fitting
19:1	237-81	1	O-Ring
20	66-9300	2	Screw-HF
21	98-4702	1	Pump - Gear, Tandem
21:1	98-4700	1	Key-Square
*21:2	99-1353	1	Kit-Seal, Pump

Ref. No.	Part No.	Qty.	Description
22	321-3	4	Screw-HH
23	3253-3	4	Washer-Lock
24	99-5119	1	Fan
25	99-1439	1	Adapter-Fan
26	99-1449	1	Pump Mount ASM
26:2	98-0068	1	Shaft-Fan
26:3	38-7820	2	Bearing-Ball
27	100-1715	2	Key-Square
28	3231-5	1	Screw-CARR
29	99-5111	1	Pulley-Keyed
30	33096-00	2	Washer-Flat
31	98-8089	2	Nut-Lock
32	71-4411	2	Spacer
33	5-1470	2	Capscrew
34	104-2548	1	Muffler-Diesel
35	3217-6	3	Nut-Hex
36	3253-4	13	Washer-Lock
37	100-2238	1	Gasket-Muffler
38	322-9	3	Screw-HH
39	99-5132	1	Bolt
40	99-5133	2	Bolt
41	99-1431	1	Adapter-Flywheel

* Not illustrated

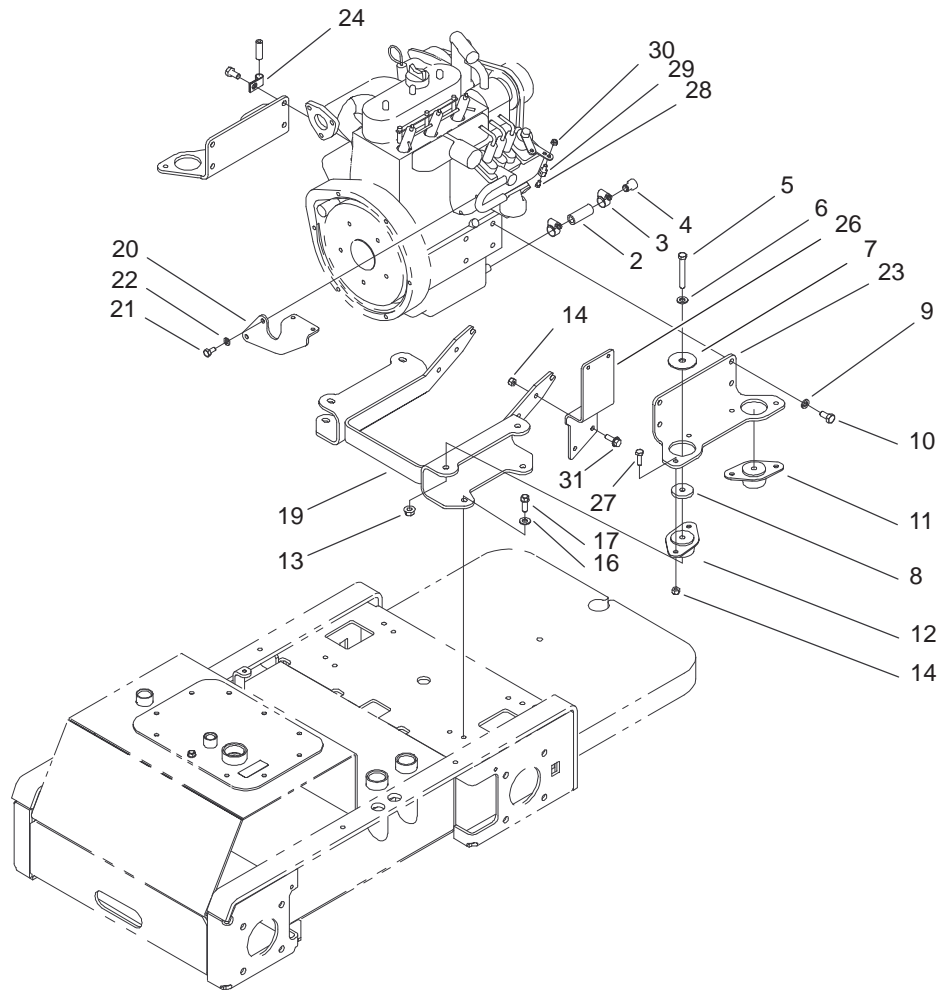

Sheet No.: 6

Engine Mount Assembly

Ref. No.	Part No.	Qty.	Description	Ref. No.	Part No.	Qty.	Description
2	56-2230	1	Hose-Fuel	29	93-0021	1	Swivel-Cable, Throttle
3	2412-36	2	Clamp-Hose	30	3296-13	1	Nut-Lock NI
4	99-1445	1	Plug-Oil, Diesel	31	3234-29	2	Screw-HHF
5	323-13	4	Screw-HH				
6	3256-24	4	Washer-Flat				
7	87-5100	4	Washer-Snubbing				
8	98-4596	4	Washer-Mount, Engine				
9	42-9600	6	Lockwasher-Spring				
10	99-5130	7	Bolt				
11	83-1030	2	Mount-Engine				
12	93-5265	2	Mount-Engine				
13	32128-29	4	Locknut-Flange				
14	3296-29	10	Nut-Lock				
16	3256-80	4	Washer-Flat				
17	95-1726	4	Screw-Taptite W/Patch				
19	98-0066-01	1	Engine Mount Wa				
20	99-5007-01	1	Mount-Solenoid				
21	99-5132	2	Bolt				
22	3253-4	2	Washer-Lock				
23	98-0055-01	2	Plate-Mount, Engine				
24	2412-138	1	R-Clamp				
26	98-0059-01	1	Mount-Filter, Fuel				
27	322-5	8	Screw-HH				
28	25-8640	1	Screw-HH				

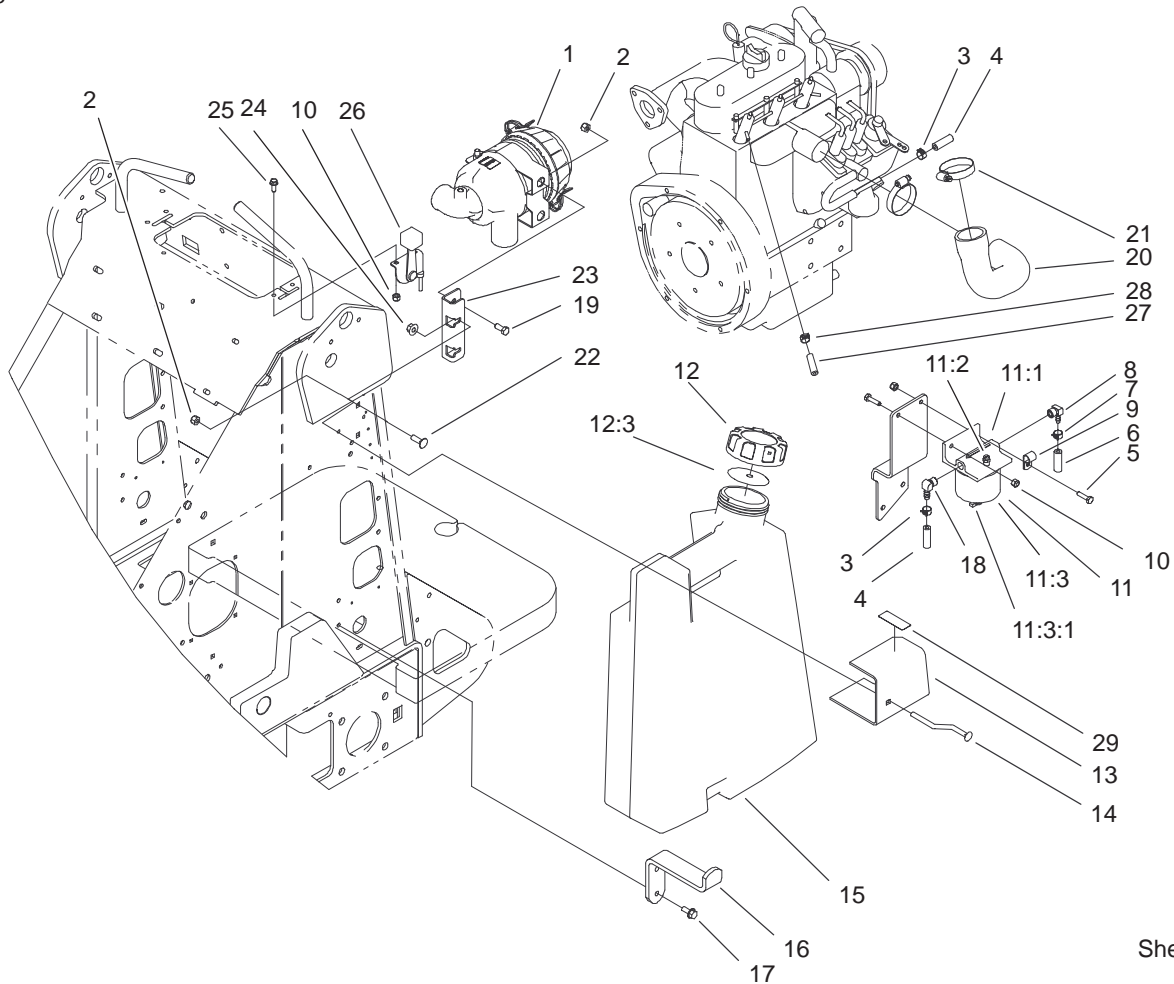

Sheet No.: 7

Fuel Tank and Air Filter Assembly

Ref. No.	Part No.	Qty.	Description
1	99-3160	1	Air Cleaner ASM
2	3296-29	3	Nut-Lock
3	92-2379	1	Clamp-Hose
4	63-7627	1	Hose-Fuel
5	321-6	2	Screw-HH
6	99-1438	1	Hose-Fuel
7	2412-98	2	Clamp
8	304-96	1	Elbow
9	2412-73	1	Clamp-R
10	3296-42	4	Nut-Lock, NI
11	63-7650	1	Separator-Filter/Water
11:1	63-8280	1	Head ASM
11:2	63-8290	1	Vent-Air
11:3	63-8300	1	Element-Spin-On
11:3:1	63-8310	1	Valve-Drain
12	104-7419	1	Cap-Fuel, Diesel
12:3	104-7420	1	Gasket-Vented
13	99-1444-03	1	Plate-Mount, Left
14	98-4657	1	Bolt-Mount
15	105-4050	1	Fuel Tank ASM, Diesel LH
*15:1	46-6560	2	Bushing
*15:2	100-1596	1	Fitting-90°
*15:3	104048	1	Valve-Fuel
16	98-4656-03	1	Mount-Bottom, Tank
17	32144-70	2	Screw-HH

Ref. No.	Part No.	Qty.	Description
18	353-781	1	Fitting
19	322-3	2	Screw-HH
20	99-5041	1	Hose-Cleaner, Air
21	2412-92	1	Clamp-Hose
22	3230-2	2	Screw-CARR
23	99-3080-03	1	Mount-Cleaner, Air
24	32128-20	2	Nut-HF
25	3234-33	2	Screw-HHF
26	99-1422	1	Control-Throttle
27	76-4420	1	Hose-Line, Fuel
28	2412-80	2	Fuel Line Clamp
29	93-6680	1	Decal-Diesel Only

* Not illustrated

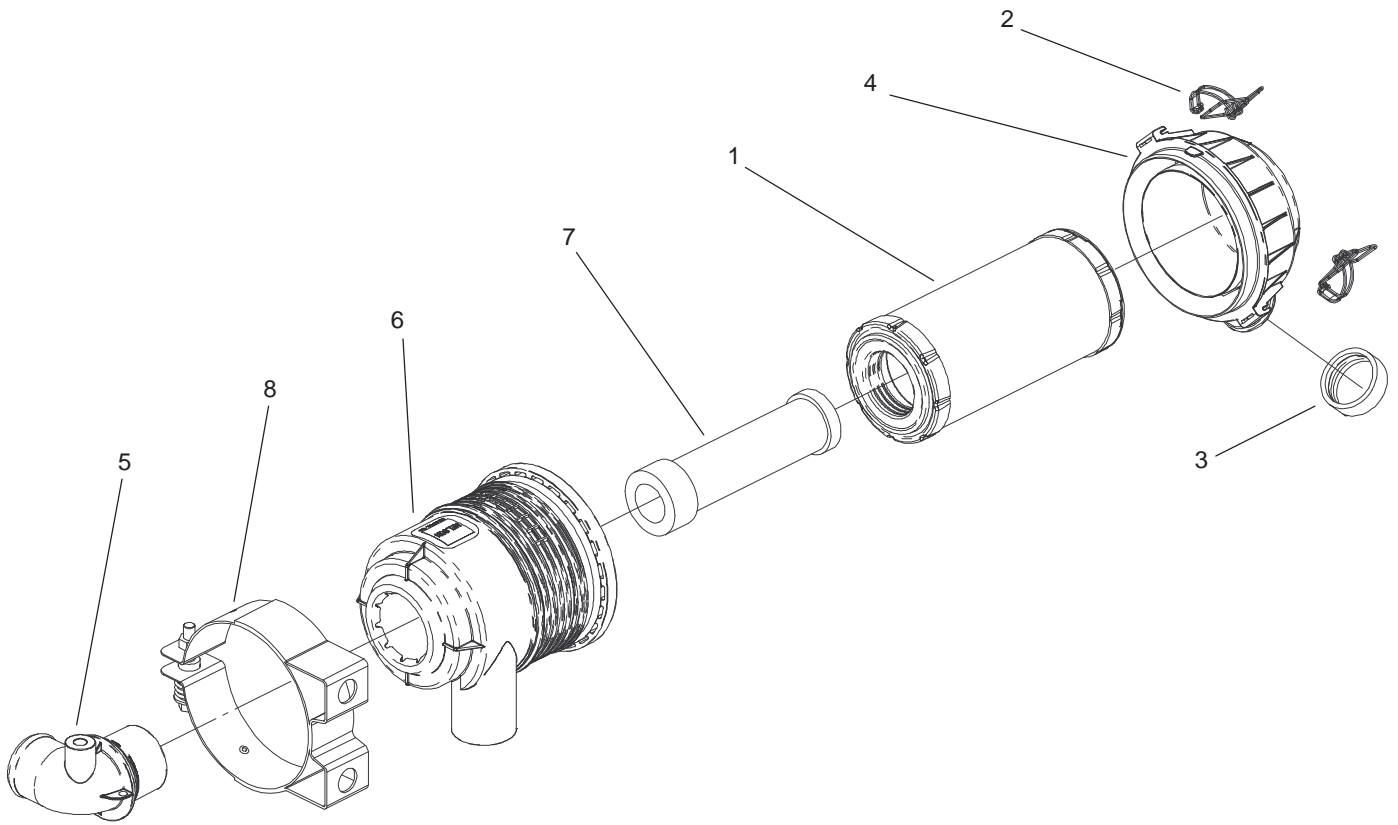

Sheet No.: A3
C-3006

Air Cleaner Assembly No. 99-3160

Ref. No.	Part No.	Qty.	Description
1	99-3173	1	Element-Filter, Air
2	99-3174	2	Clip-Cleaner, Air
3	99-3175	1	Valve-Ejector, Dust
4	99-3176	1	Cover-Air Cleaner
5	99-3183	1	Tube ASM
6	99-3184	1	Housing-Air Cleaner
7	99-3198	1	Filter-Safety
8	99-3197	1	Filter Mount Bracket ASM

Ref. No.	Part No.	Qty.	Description

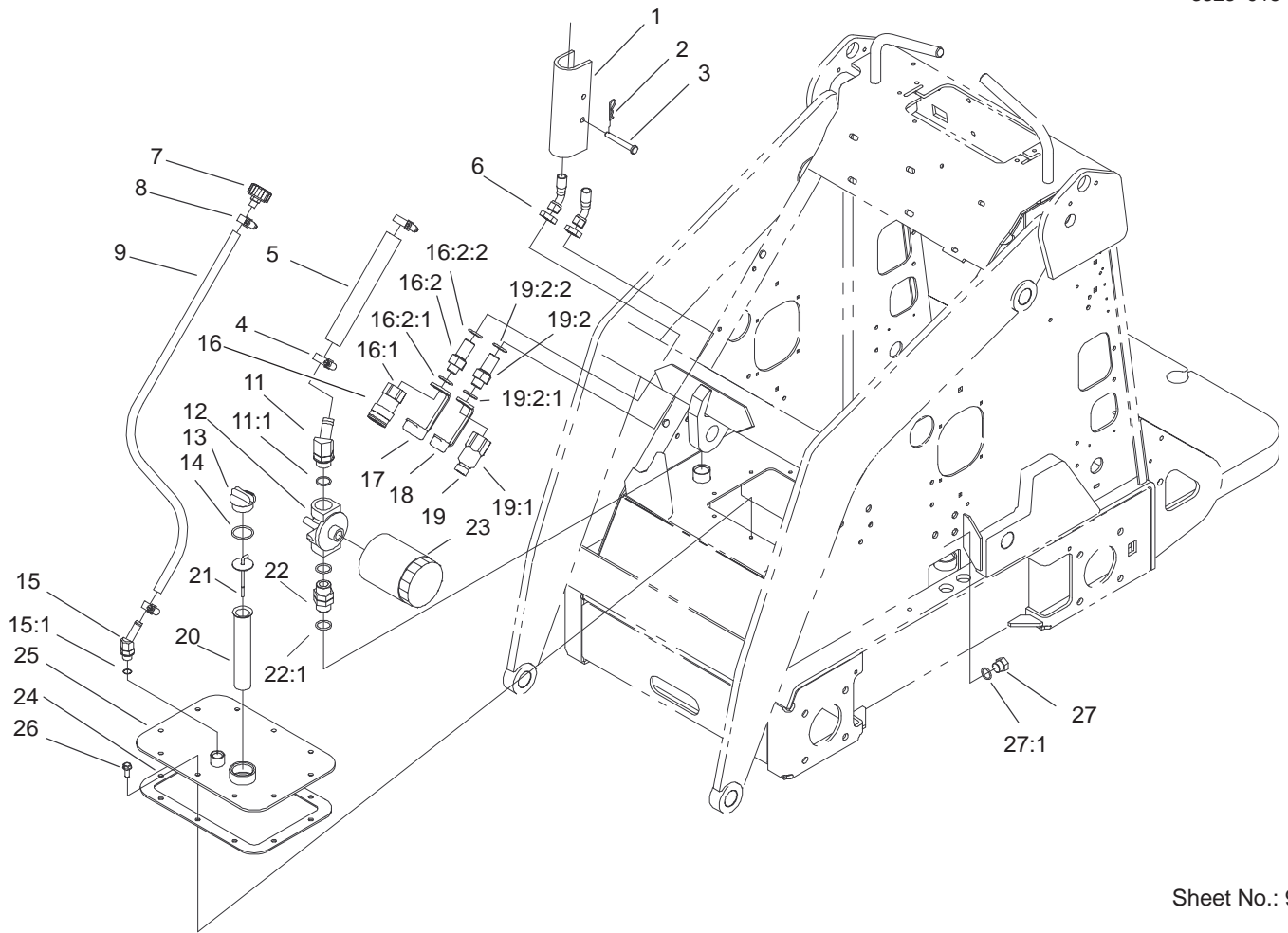

Sheet No.: 9

Hydraulic Tank and Filter Assembly

Ref. No.	Part No.	Qty.	Description
1	98-4675-01	2	Lock-Cylinder
2	3290-467	2	Pin-Hair
3	283-52	2	Pin-Clevis
4	2412-129	2	Clamp-Hose
5	98-2713	1	Hose-Suction, Hydraulic
6	340-74	2	Locknut-Bulkhead
7	68-6150	1	Breather-Air
8	2412-36	2	Clamp-Hose
9	100-1748	1	Hose-Vent
11	354-127	1	Elbow-45°
11:1	237-81	1	O-Ring
12	92-5821	1	Filter Head ASM
13	93-7498	1	Plug-Plastic
14	237-123	1	O-Ring
15	354-126	1	Fitting-HYD, 45
15:1	237-79	1	O-Ring
16		1	Bulkhead Coupler ASM
16:1	96-1275	1	Coupler-Face, Flush
16:2	100-4236	1	Fitting-Adapter, Bulkhead
16:2:1	237-65	1	O-Ring
16:2:2	237-80	1	O-Ring
17	100-8815	1	Cap-Dust, Nipple
18	100-8816	1	Cap-Dust, Coupler

Ref. No.	Part No.	Qty.	Description
19	100-4748	1	Bulkhead Nipple ASM
19:1	96-1276	1	Nipple-Face, Flush
19:2	100-4236	1	Fitting-Adapter, Bulkhead
19:2:1	237-65	1	O-Ring
19:2:2	237-80	1	O-Ring
20	61-2790	1	Filter-Screen
21	100-2097	1	Dipstick-Oil
22	98-9906	1	Fitting-Thread, Straight
22:1	237-81	2	O-Ring
23	54-0110	1	Filter-Oil, Transmission
24	98-9927	1	Gasket-Cover
25	100-1713-01	1	Cover ASM
26	98-9940	10	Screw
27	353-988	1	Plug-Hex, Hollow
27:1	237-79	1	O-Ring

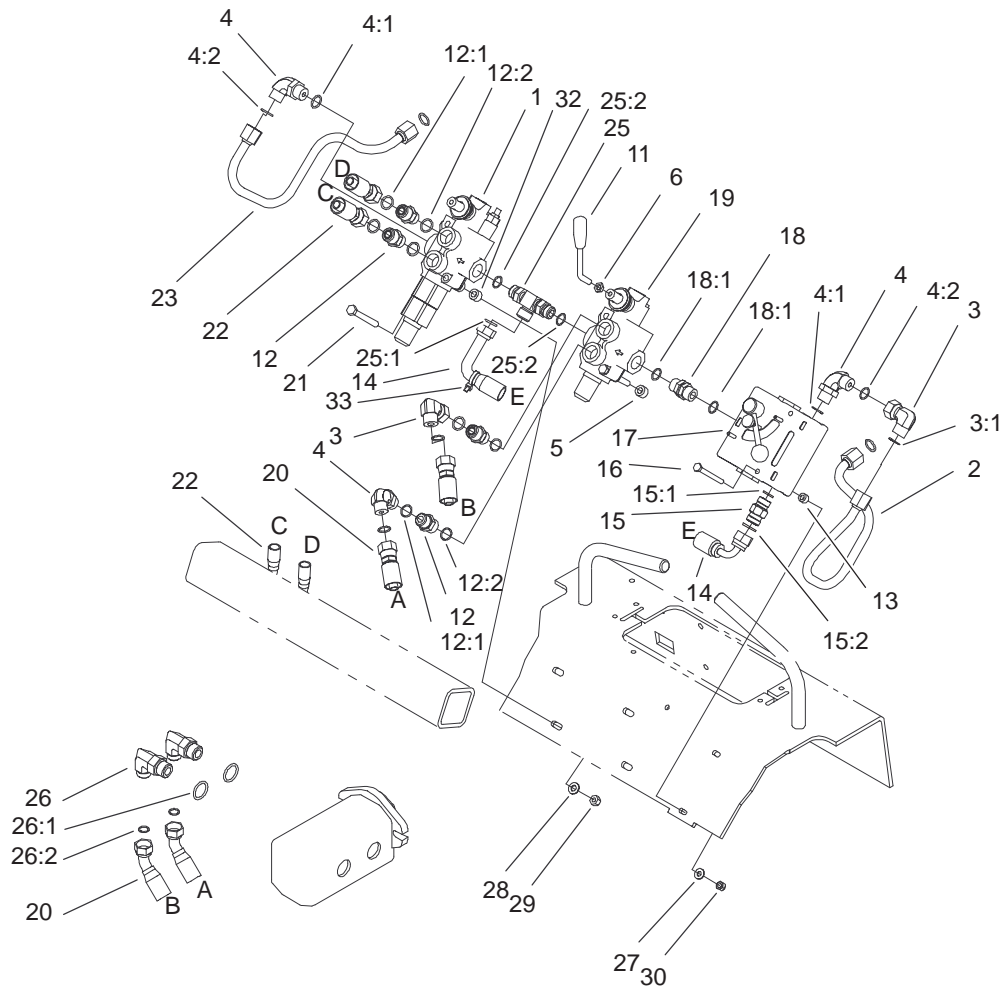

Sheet No.: 11

Hydraulic Valve Assembly

Ref. No.	Part No.	Qty.	Description
1	99-3077	1	Valve-Aux, Hydraulic
2	99-3030	1	Line-Hydraulic, Cf
3	94-6031	2	Fitting-HYD
3:1	237-30	1	O-Ring
4	340-98	3	Fitting-HYD, 90°
4:1	237-79	1	O-Ring
4:2	237-30	1	O-Ring
5	98-4695	2	Tube-Spacer
6	42-9580	1	Nut-Hex
11	98-4729	1	Lever-Valve
12		3	Adapter
12:1	237-30	2	O-Ring
12:2	237-79	2	O-Ring
13	98-4799	2	Tube-Spacer
14	100-2245	1	Hose ASM
15	98-4735	1	Valve-Check, HYD
15:1	237-30	1	O-Ring
15:2	237-79	1	O-Ring
16	321-14	2	Screw-HH
17	104-4221	1	Kit-Valve, Hydraulic
18	95-3209	1	Fitting-Thread, Straight
18:1	237-79	2	O-Ring
19	99-3072	1	Valve-Selector, Hydraulic
20	100-1730	2	Hose-Pump, HYD

Ref. No.	Part No.	Qty.	Description
21	322-13	4	Screw-HH
22	100-8817	2	Hose-Aux
23	98-4724	1	Line-Aux, Hydraulic
25	98-9079	1	Adapter - Tee, Adjustable
25:1	237-30	1	O-Ring
25:2	237-79	2	O-Ring
26	340-105	2	Fitting-90°
26:1	237-80	1	O-Ring
26:2	237-30	1	O-Ring
27	3256-22	2	Washer-Flat
28	3256-23	4	Washer-Flat
29	3296-29	4	Nut-Lock
30	3296-42	2	Nut-Lock, NI
32	100-2085	2	Tube-Spacer
33	3290-379	10	Tie-Cable

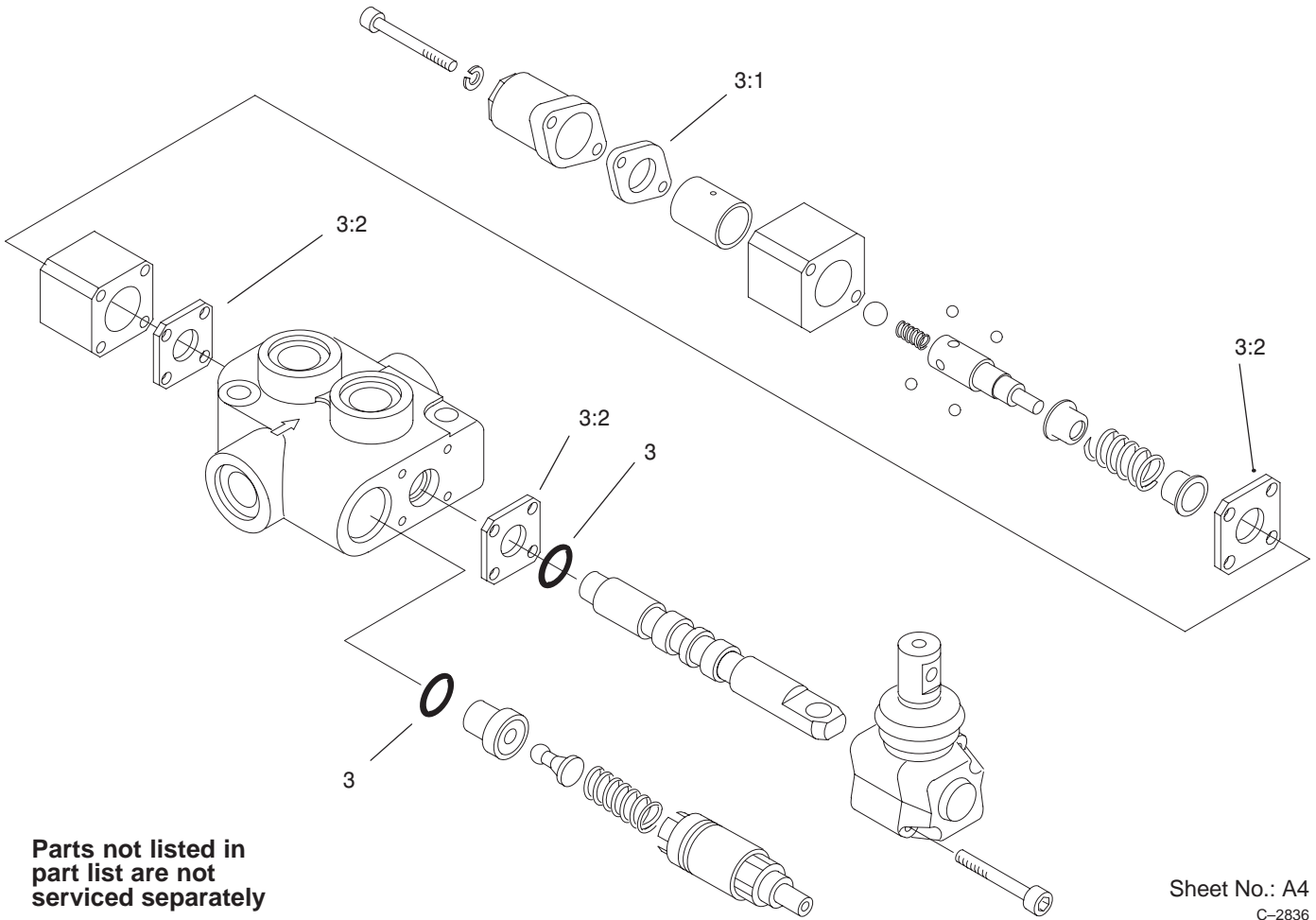

Parts not listed in
part list are not
serviced separately

Sheet No.: A4
C-2836

Hydraulic Valve Assembly No. 99-3077

Ref. No.	Part No.	Qty.	Description
3	99-4391	1	Kit-Seal
3:1	99-3074	1	Gasket
3:2	99-3075	3	Gasket

Ref. No.	Part No.	Qty.	Description

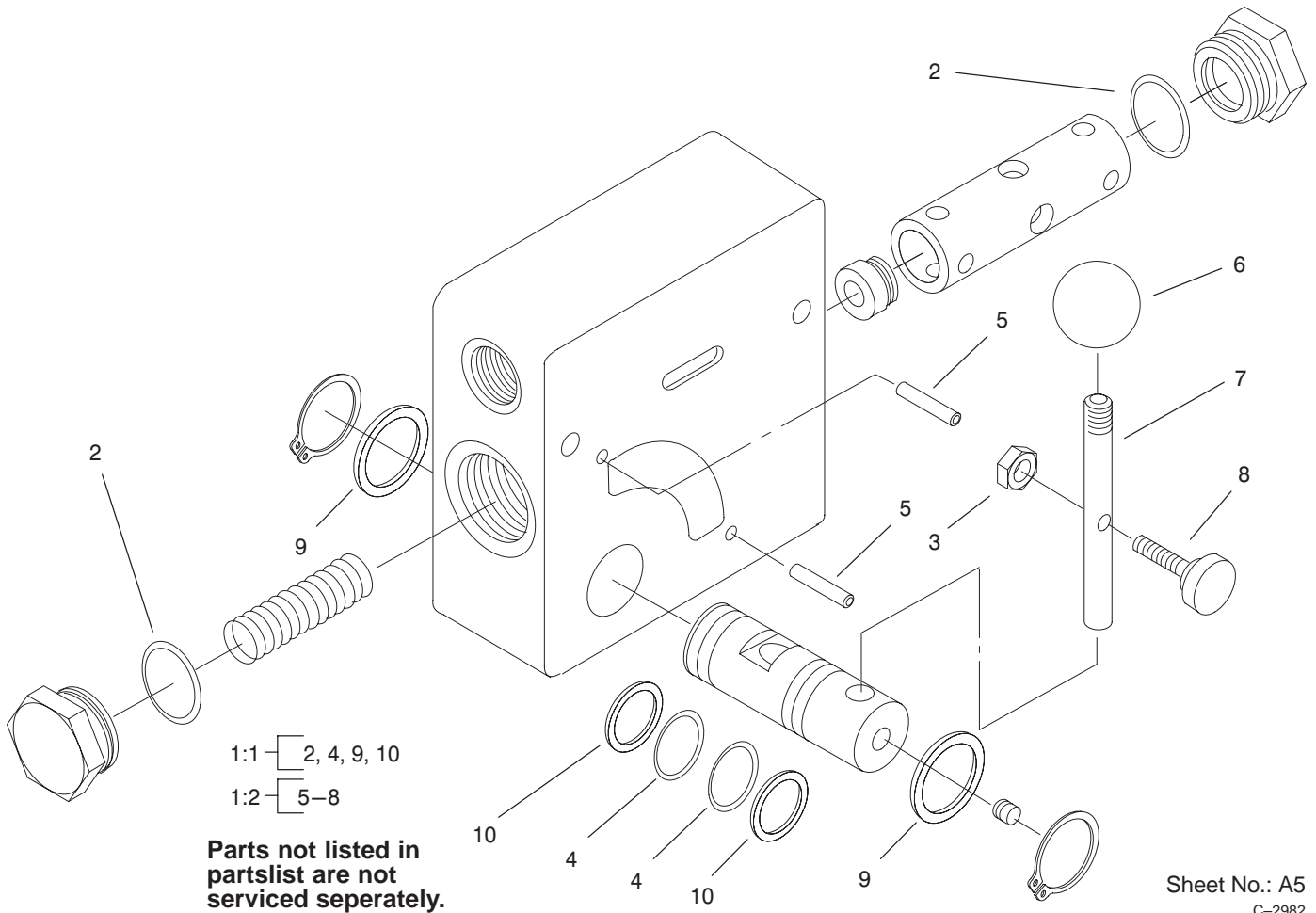

Sheet No.: A5
 C-2982

Hydraulic Valve Assembly No. 104-4221

Ref. No.	Part No.	Qty.	Description
☆1		1	Valve-Flow, Hydraulic
1:1	104-4231	1	Kit-Seal, Valve
1:2	98-9098	1	Kit-Hardware, Handle
3	3296-27	1	Nut-Lock NI

Ref. No.	Part No.	Qty.	Description

☆ Not serviced

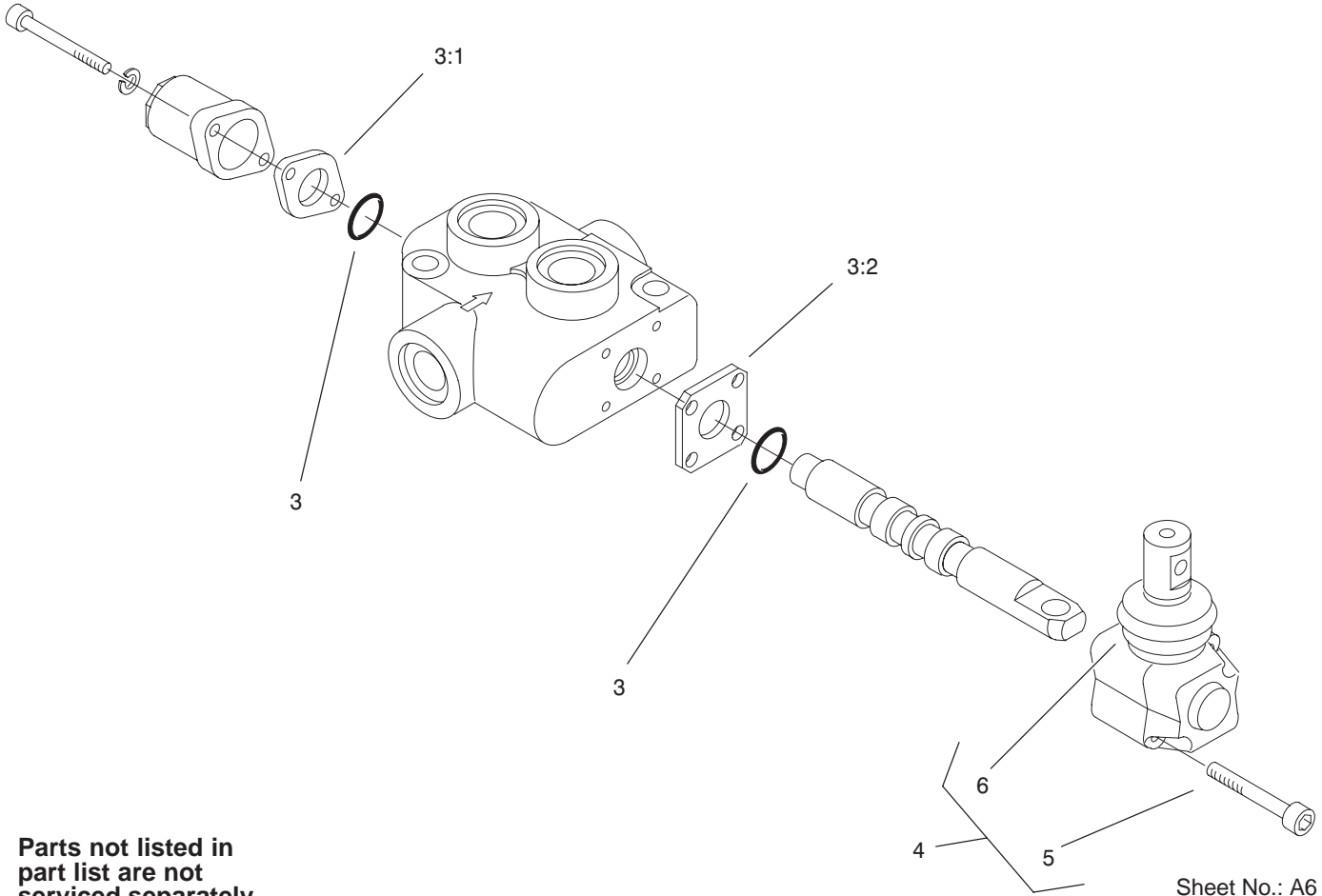

Parts not listed in part list are not serviced separately

Sheet No.: A6
C-2983

Hydraulic Valve Assembly No. 99-3072

Ref. No.	Part No.	Qty.	Description
3	99-4391	1	Kit-Seal
3:1	99-3074	1	Gasket
3:2	99-3075	3	Gasket

Ref. No.	Part No.	Qty.	Description

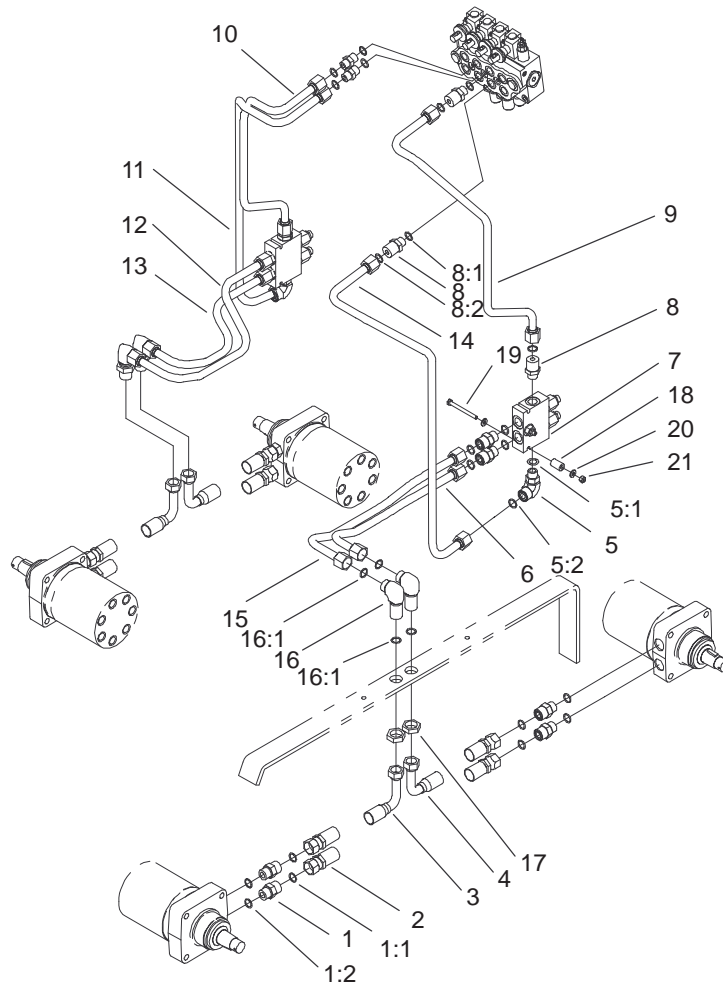

Sheet No.: 14

Hydraulic Motor Assembly

Ref. No.	Part No.	Qty.	Description
1	340-7	8	Adapter
1:1	237-65	1	O-Ring
1:2	237-80	1	O-Ring
2	99-3012	2	Hose-Motor, HYD
3	99-3010	2	Hose-Motor, Front HYD
4	99-3011	2	Hose-Motor, Rear HYD
5	340-153	2	Fitting-HYD
5:1	237-79	1	O-Ring
5:2	237-151	1	O-Ring
6	99-3022	1	Line-Hydraulic
7	99-3040	2	Valve-Counterbalance
8	340-155	10	Fitting-HYD
8:1	237-79	1	O-Ring
8:2	237-151	1	O-Ring
9	99-3027	1	Line-Hydraulic
10	99-3024	1	Line-Hydraulic
11	99-3029	1	Line-Hydraulic
12	99-3025	1	Line-Hydraulic
13	99-3028	1	Line-Hydraulic
14	99-3023	1	Line-Hydraulic
15	99-3026	1	Line-Hydraulic
16	340-72	4	Elbow-Bulkhead Union, 90°
16:1	237-65	2	O-Ring

Ref. No.	Part No.	Qty.	Description
17	340-74	4	Locknut-Bulkhead
18	99-3057	2	Spacer-Valve
19	321-23	2	Screw-HH
20	3256-22	4	Washer-Flat
21	3296-42	2	Nut-Lock, NI

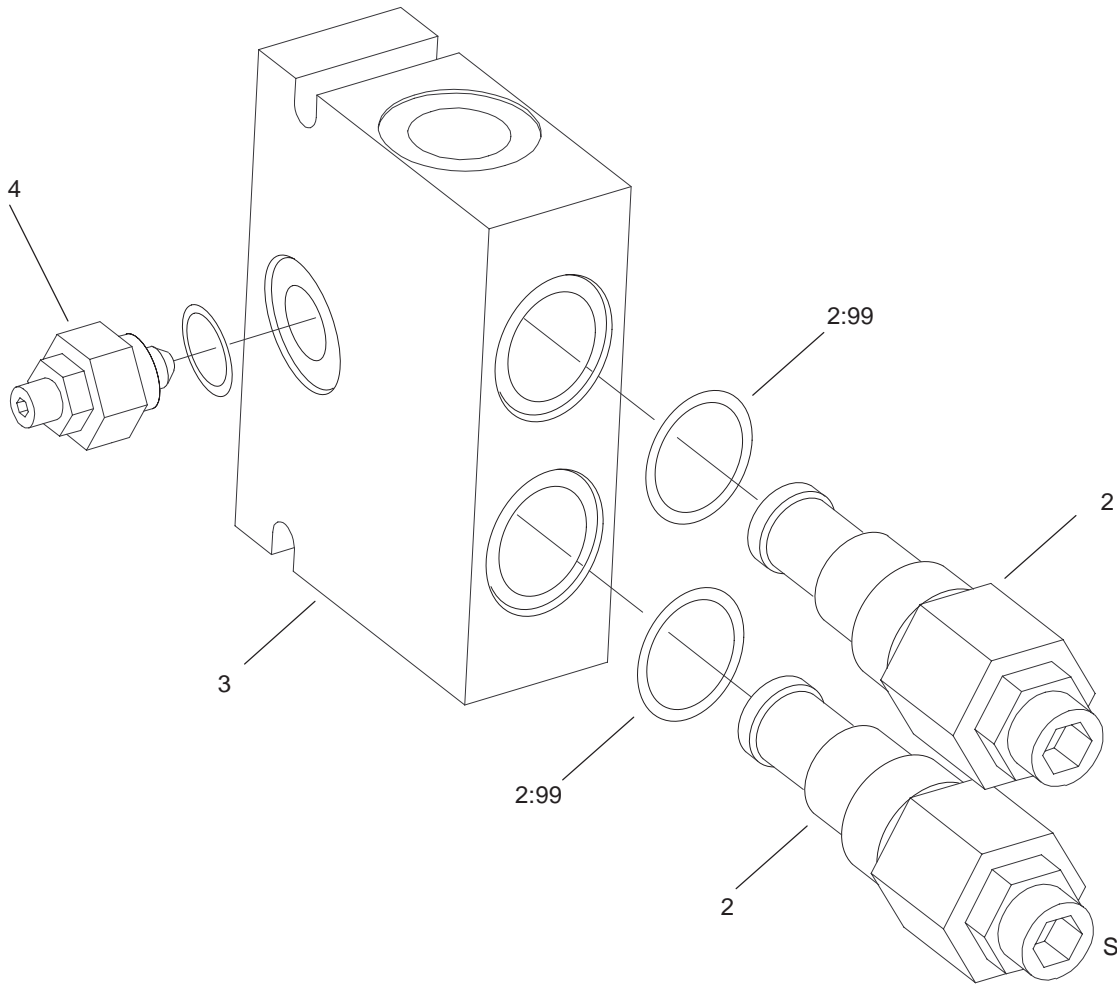

Sheet No.: A8
C-3005

Counterbalance Valve Assembly No. 99-3040

Ref. No.	Part No.	Qty.	Description
2	99-3271	2	Valve – Cartridge
2:99	98-2712	1	Kit-Seal, Valve
3	100-8864	1	Manifold ASM
4	100-8865	1	Needle Valve ASM

Ref. No.	Part No.	Qty.	Description

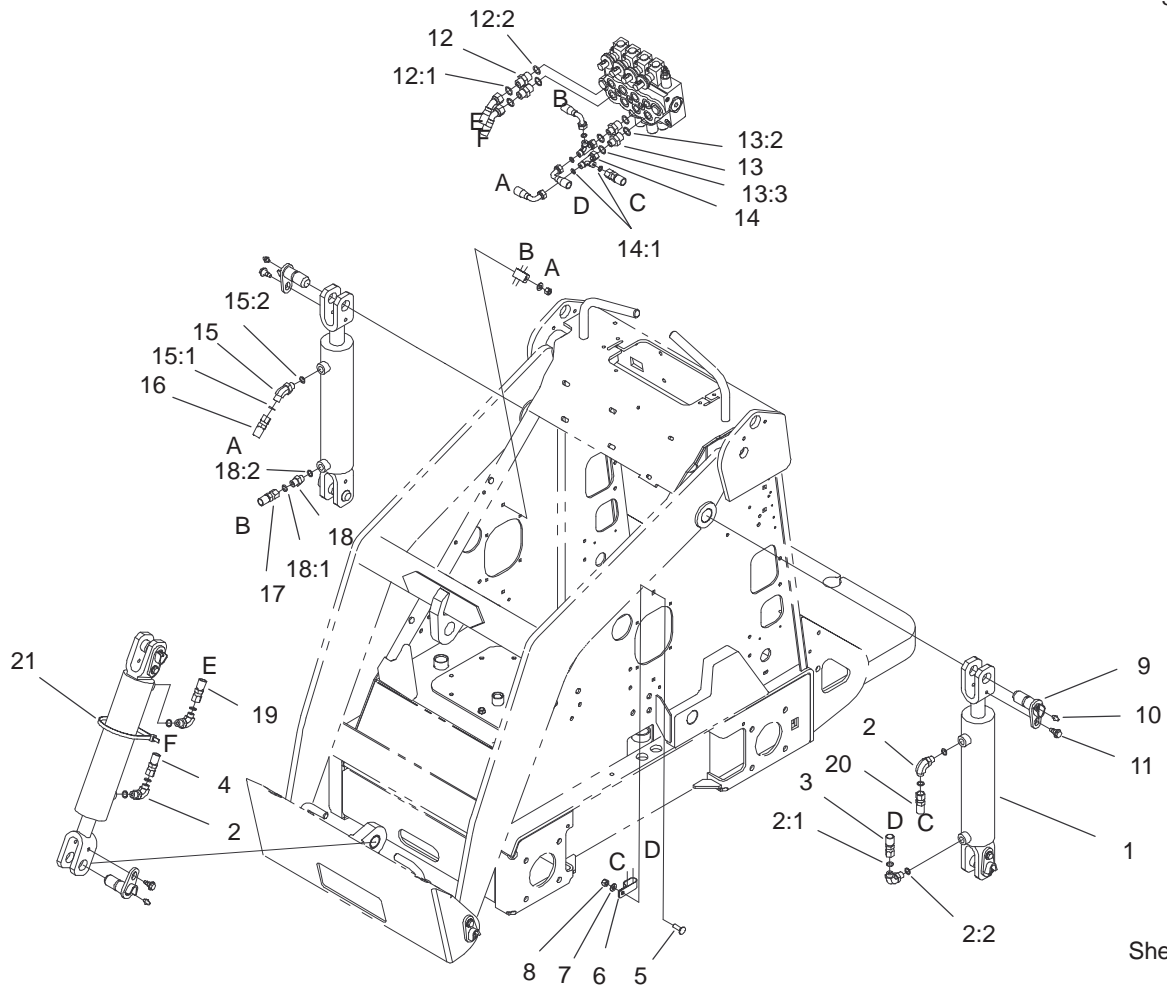

Sheet No.: 15

Hydraulic Cylinder Assembly

Ref. No.	Part No.	Qty.	Description
1	100-4163	3	Kit-Cylinder, Hydraulic
2	340-82	4	Adapter
2:1	237-42	2	O-Ring
2:2	237-21	2	O-Ring
3	98-4748	1	Hose-HYD, Lo Pressure
4	98-4726	1	Hose-HYD
5	3230-2	2	Screw-CARR
6	2412-137	2	Clamp-Tube
7	3256-23	2	Washer-Flat
8	3296-29	2	Nut-Lock
9	99-1414	2	Pin-Pivot
10	302-5	6	Fitting-Grease
11	99-5105	2	Bolt-Shoulder
12	340-3	2	Adapter
12:1	237-22	1	O-Ring
12:2	237-79	1	O-Ring
13	340-133	2	Adapter
13:2	237-79	1	O-Ring
13:3	237-21	1	O-Ring
14	340-151	2	Fitting
14:1	237-75	3	O-Ring
15	340-137	1	Fitting
15:1	237-21	1	O-Ring
15:2	237-42	1	O-Ring

Ref. No.	Part No.	Qty.	Description
16	98-4725	1	Hose-Loader, Hydraulic
17	100-1731	1	Hose-HYD, Right
18	340-1	1	Adapter
18:1	237-35	1	O-Ring
18:2	237-42	1	O-Ring
19	98-4727	1	Hose-HYD
20	99-3109	1	Hose-Loader, HYD
21	3334-945	1	Tie-Cable

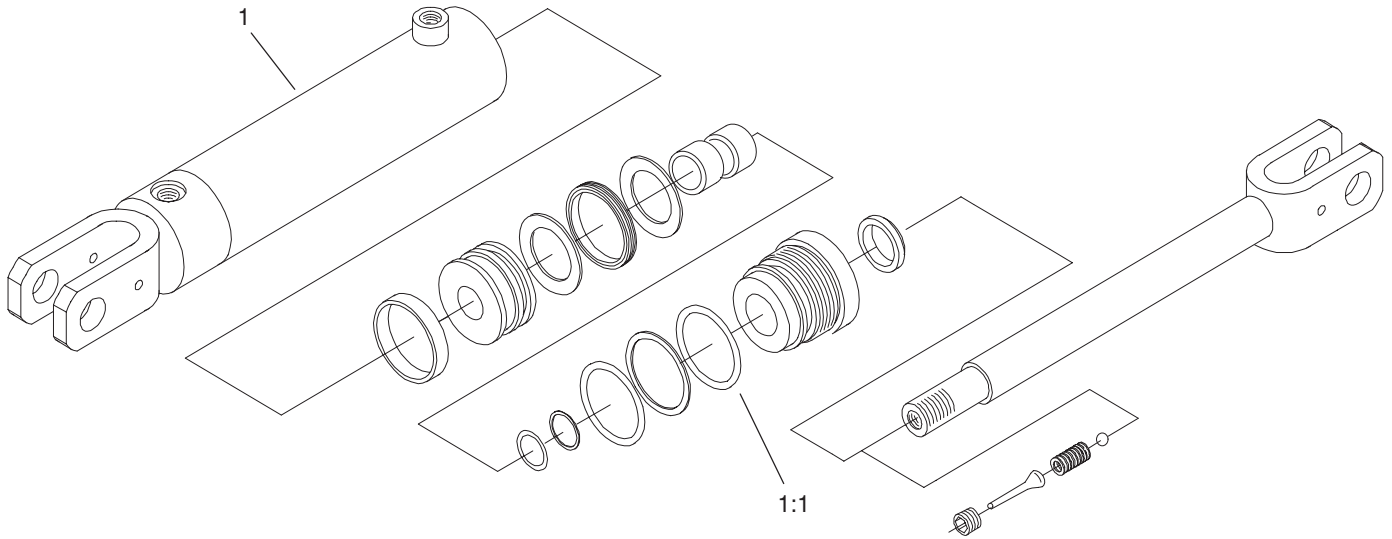

Parts not listed in
part list are not
serviced separately

Sheet No.: A9
C-2824

Hydraulic Cylinder Assembly No. 100-4163

Ref. No.	Part No.	Qty.	Description
1		1	Cylinder-Hydraulic
1:1	99-3065	1	Kit-Seal, Hydraulic Cylinder

Ref. No.	Part No.	Qty.	Description

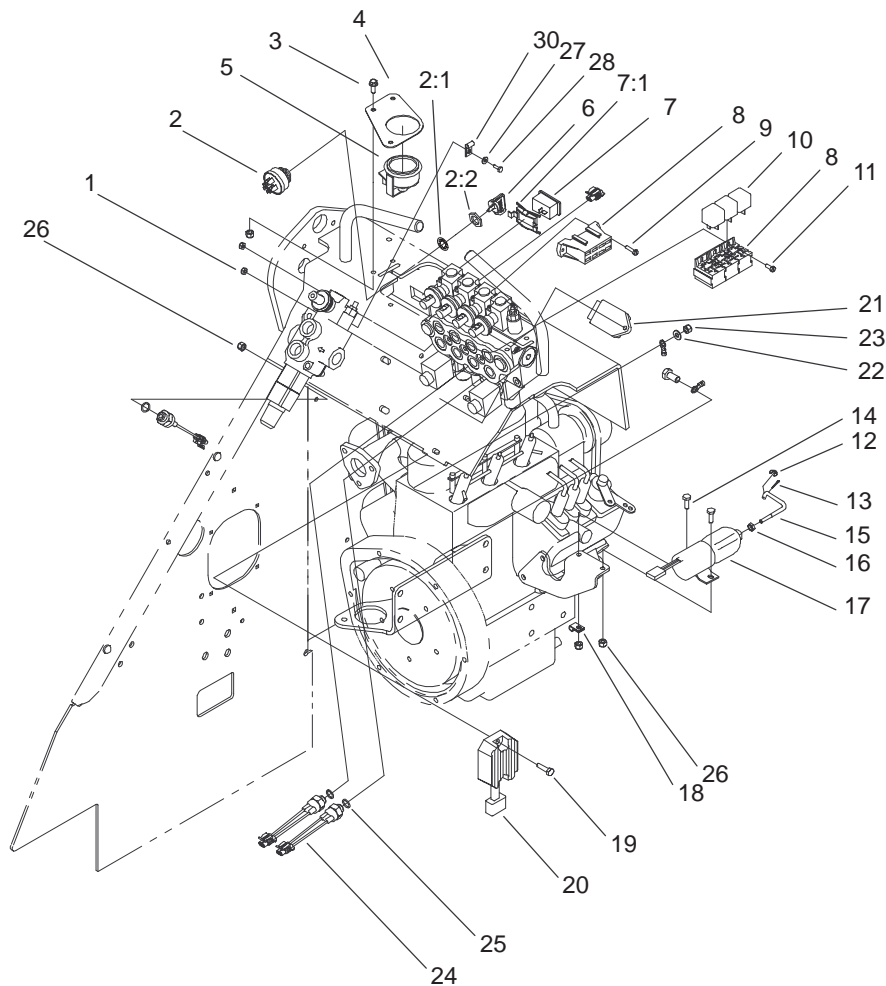

Sheet No.: 20

Electrical Components Assembly

Ref. No.	Part No.	Qty.	Description
1	3296-12	4	Nut-Lock
2	111216	1	Ignition Switch ASM
2:1	9201604	1	Lockwasher
2:2	101884	1	Nut
3	3234-33	3	Screw-HHF
4	100-1707-01	1	Mount-Lamp, Warning
5	100-1732	1	Cluster-Lamp
6	63-8360	2	Key-Ignition
7	104-7429	1	Hour Meter-Dc, Mini
7:1	104-4234	1	Clip-Mounting, Hourmeter
8	104-7410	1	Wire Harness, Dingo Kubota
9	32105-13	2	Screw-SHH
10	98-7249	3	Relay
11	32105-8	2	Screw
12	52-5910	1	Ring-Retaining
13	3272-1	1	Pin-Cotter
14	321-4	2	Screw-HH
15	99-1423	1	Rod-Linkage, Threaded
16	3220-1	1	Nut-Jam
17	99-5006	1	Solenoid-Kubota
18	2412-31	1	Clamp-Boden
19	321-6	1	Screw-HH
20	100-2057	1	Regulator ASM

Ref. No.	Part No.	Qty.	Description
21	98-7611	1	Controller-Glow
22	100-2215	1	Washer-Spring
23	100-2171	1	Nut-Hexagon
24	72-4310	2	Switch
25	237-42	2	O-Ring
26	3296-42	8	Nut-Lock, NI
27	3256-21	1	Washer-Flat
28	32144-87	1	Screw-Forming, Thread
30	2412-72	1	Clip-Closed, Insulated

Electrical Schematic

KUBOTA DINGO SCHEMATIC

KEY SWITCH P/N 111216

OFF NO CONNECTION
ON B+R+I+A
START B+R+I+S

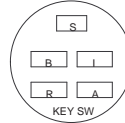

WIRE COLOR CODES

BK	BLACK	PK	PINK
BN	BROWN	R	RED
BU	BLUE	T	TAN
GN	GREEN	VIO	VIOLET
GY	GREY	W	WHITE
OR	ORANGE	Y	YELLOW

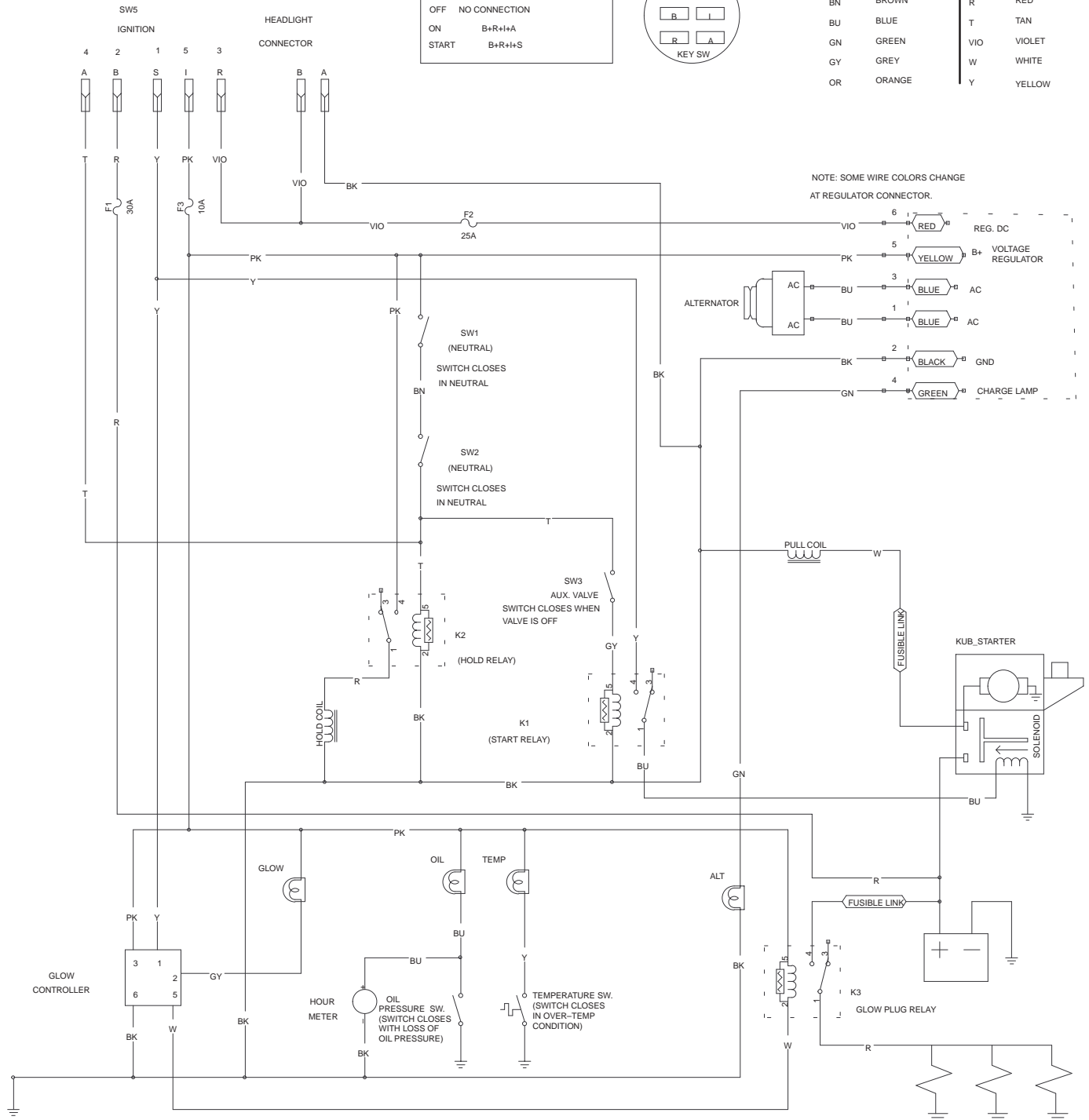

NOTE: SOME WIRE COLORS CHANGE AT REGULATOR CONNECTOR.

Hydraulic Schematic

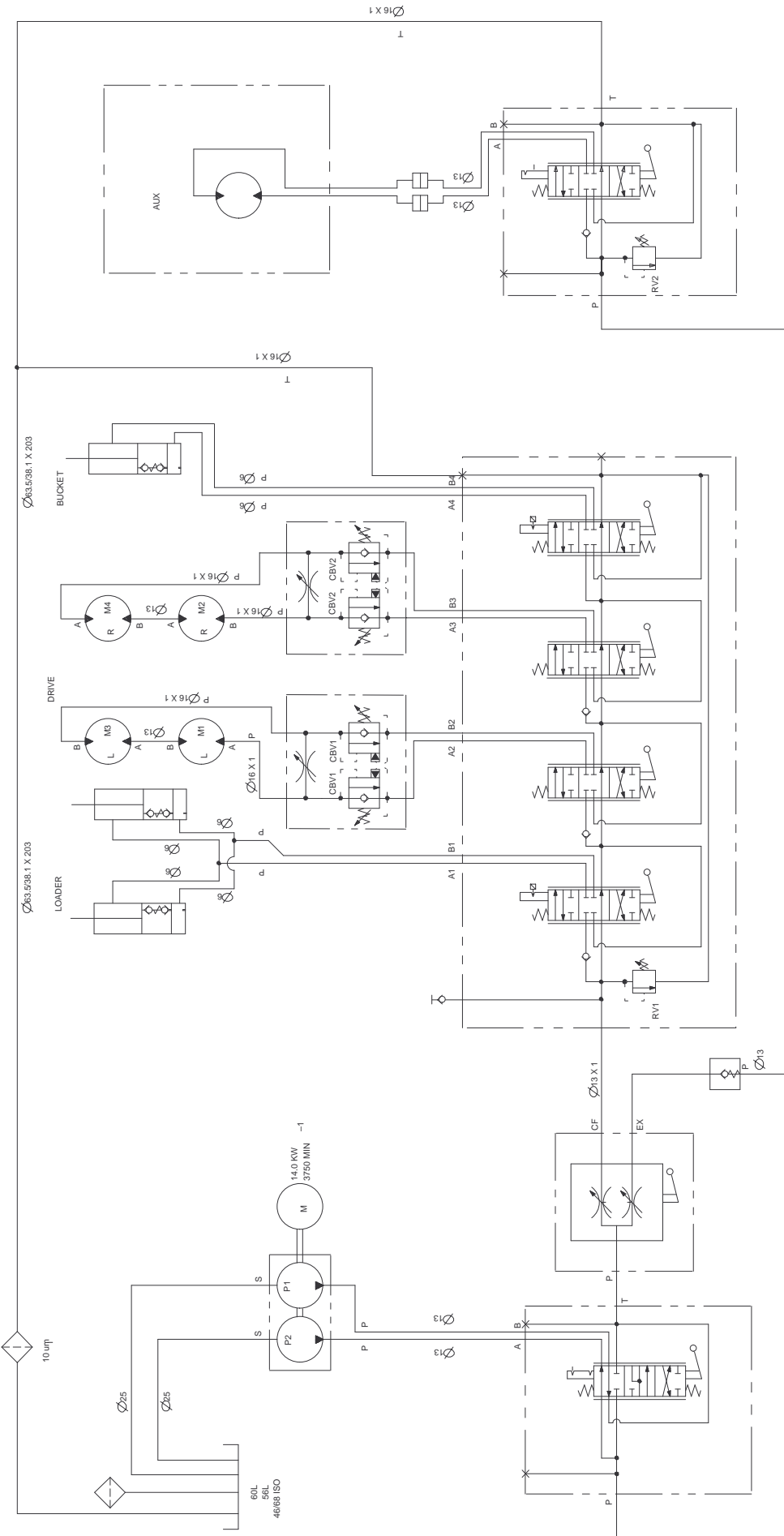

DISPLACEMENT A		ND PRESSURE CHART	
COMPONENT	DISPLACEMENT	PRESSURE	FLOWRATE*
COMPONENT	CU IN/REV	CU CM/REV	GPM
P1	0.55 CU IN	8 CC	8.5
P2	0.24 CU IN	4 CC	3.7
M1, M3	28.1 CU IN	476 CC	
M2, M4	28.1 CU IN	476 CC	
RV1		3225 PSI	222 BARS
RV2		3000 PSI	207 BARS
CBV1		1000 PSI	69 BARS
CBV2		1000 PSI	69 BARS

* FLOWRATE CALCULATED AT 3750 RPM AN D 95% EFFICIENCY.

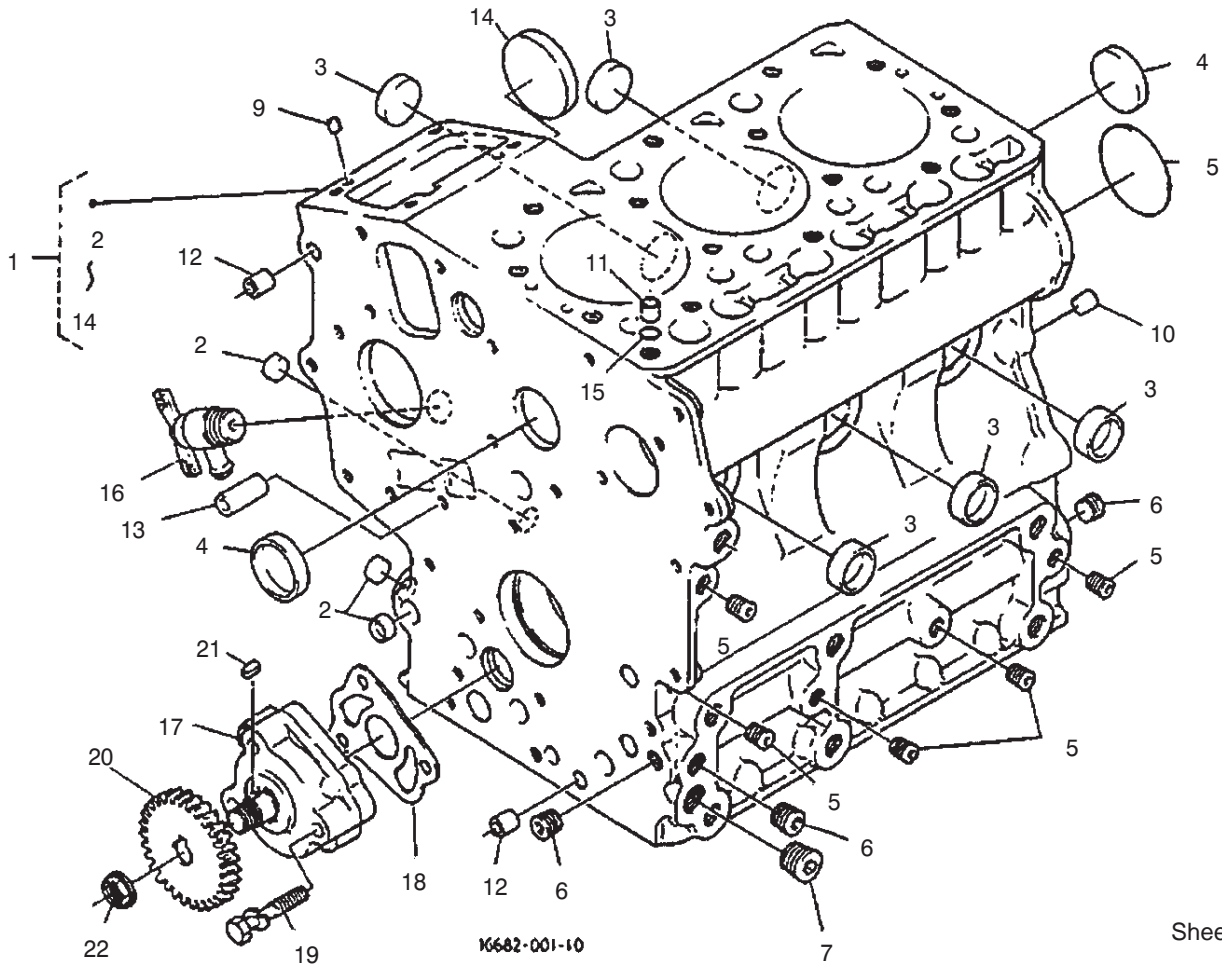

Sheet No.:2

Crankcase Assembly

Ref. No.	Part No.	Qty.	Description
1	100-2167	1	Crankcase-Comp.
2	100-2019	3	Cap-Sealing
3	100-2020	5	Cap-Sealing
4	98-9398	2	Cap-Sealing
5	98-7540	5	Cap-Sealing
6	98-7487	3	Plug
7	98-7488	1	Plug
8	100-1851	1	Plug
9	98-9375	2	Pin-Straight
10	98-9377	2	Pin-Straight
11	98-7506	1	Pin-Pipe
12	98-9387	2	Pin-Pipe
13	100-2051	2	Pin-Pipe
14	100-1991	1	Cover-Fuel, Camshaft
15	98-7509	1	O-Ring
16	98-9436	1	Drain Cock ASM
17	100-2002	1	Oil Pump ASM
18	100-2003	1	Gasket-Pump, Oil
19	100-1923	3	Bolt
20	100-1893	1	Gear-Drive, Oil Pump
21	98-7658	1	Key-Feather
22	100-1779	1	Nut-Flange

Ref. No.	Part No.	Qty.	Description

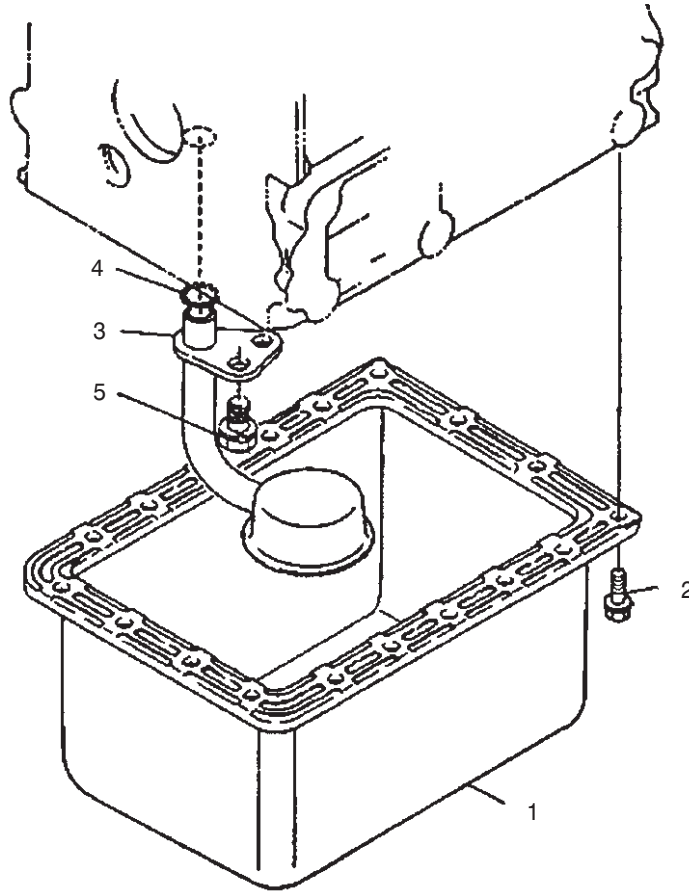

16602-002-10

Sheet No.:3

Oil Pan Assembly

Ref. No.	Part No.	Qty.	Description
1	100-2239	1	Pan-Oil, Comp.
2	98-9350	18	Bolt
3	100-2001	1	Filter-Oil
4	100-2205	1	O-Ring
5	98-7585	1	Bolt

Ref. No.	Part No.	Qty.	Description

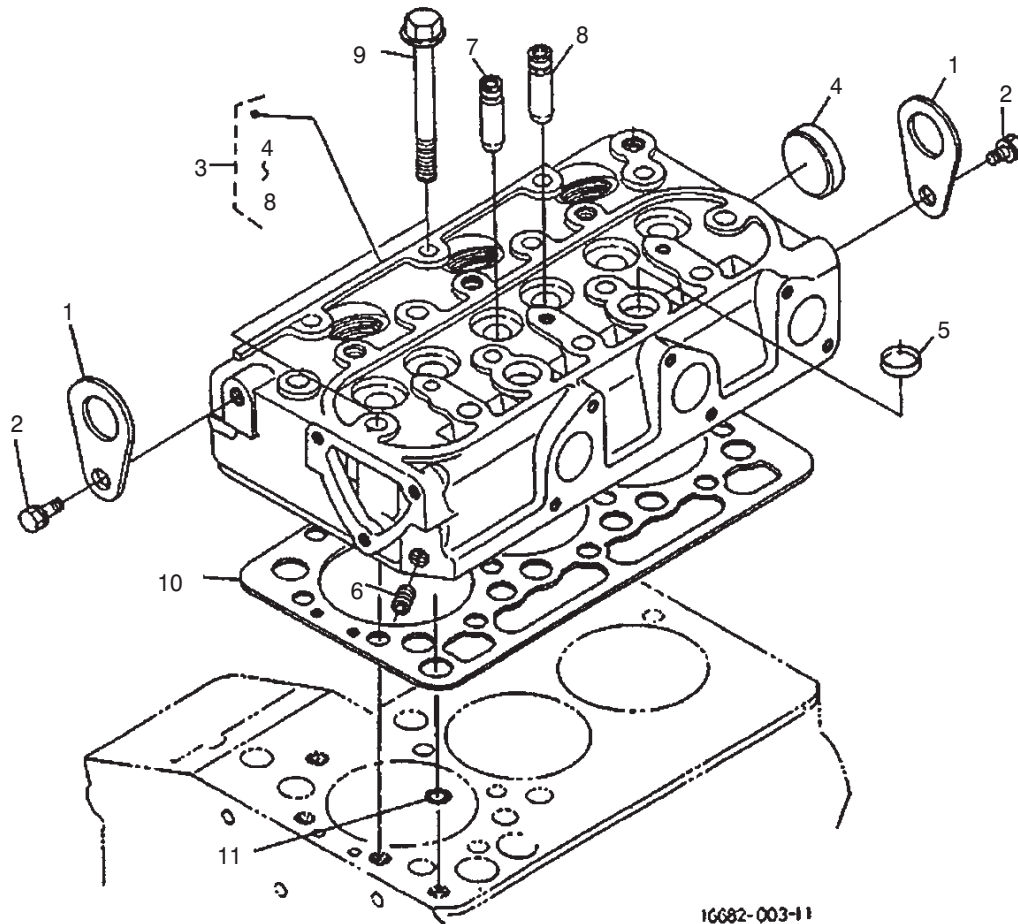

16682-003-11

Sheet No.:4

Cylinder Head Assembly

Ref. No.	Part No.	Qty.	Description	Ref. No.	Part No.	Qty.	Description
1	98-7531	2	Hook-Engine				
2	98-7526	2	Bolt				
3	100-2246	1	Head-Cylinder, Comp.				
4	98-9395	1	Cap-Sealing				
5	98-9389	2	Cap-Sealing				
6	98-7540	1	Cap-Sealing				
7	100-1882	3	Guide-Valve, Inlet				
8	100-1883	3	Guide-Valve, Exhaust				
9	100-1820	14	Bolt-Head, Cylinder				
10	100-2043	1	Gasket-Head, Cylinder				
11	98-7509	1	O-Ring				
*99	98-2651	1	Heater-Cylinder Head				

* Not illustrated

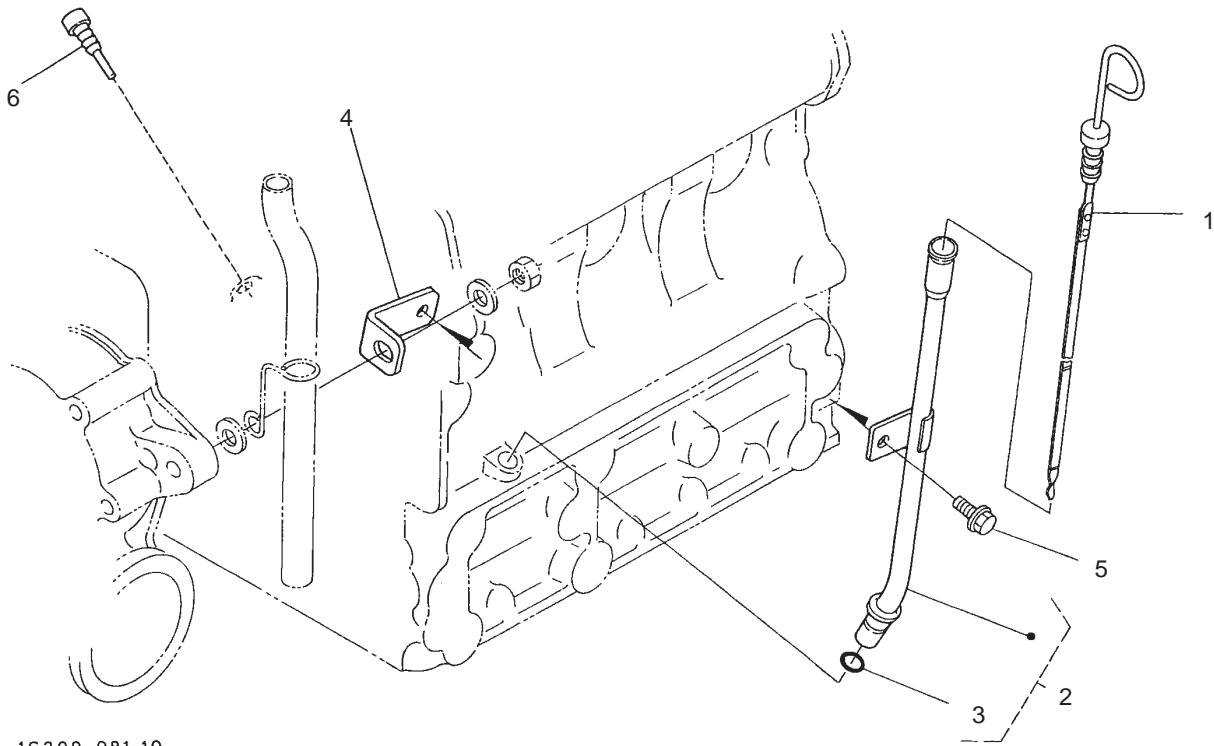

1G299-081-10

Sheet No.:7

Dipstick and Guide Assembly

Ref. No.	Part No.	Qty.	Description
1	100-2247	1	Gauge-Oil
2	100-2249	1	Oil Gauge Guide ASM
3	98-9374	1	O-Ring
4	100-2248	1	Support-Guide, Gauge
5	100-1774	1	Bolt-Flange
6	100-2229	1	Plug-Rubber

Ref. No.	Part No.	Qty.	Description

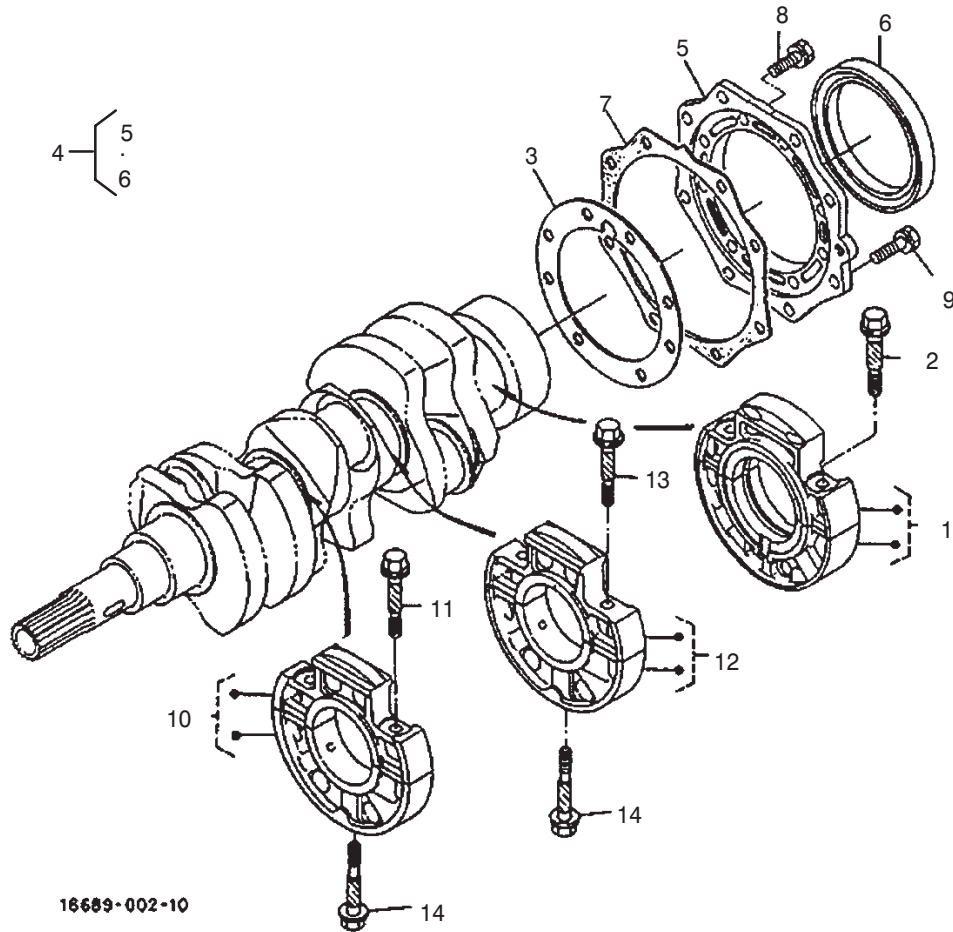

Sheet No.:8

Main Bearing Case Assembly

Ref. No.	Part No.	Qty.	Description
1	100-1988	1	Main Brg. Case ASM
2	100-1757	2	Bolt-Case, Bearing
3	100-1929	1	Gasket-Case, Bearing
4	100-2233	1	Bearing Case Cover ASM
5	100-1875	1	Cover-Case, Bearing
6	100-2055	1	Seal-Oil
7	100-1876	1	Gasket-Case, Bearing
8	98-7568	8	Bolt
9	100-1750	8	Bolt
10	100-1987	1	Main Bearing Case ASM
11	100-1757	2	Bolt-Case, Bearing
12	100-2027	1	Main Bearing Case ASM
13	100-1757	2	Bolt-Case, Bearing
14	100-1874	2	Bolt-Case, Bearing

Ref. No.	Part No.	Qty.	Description

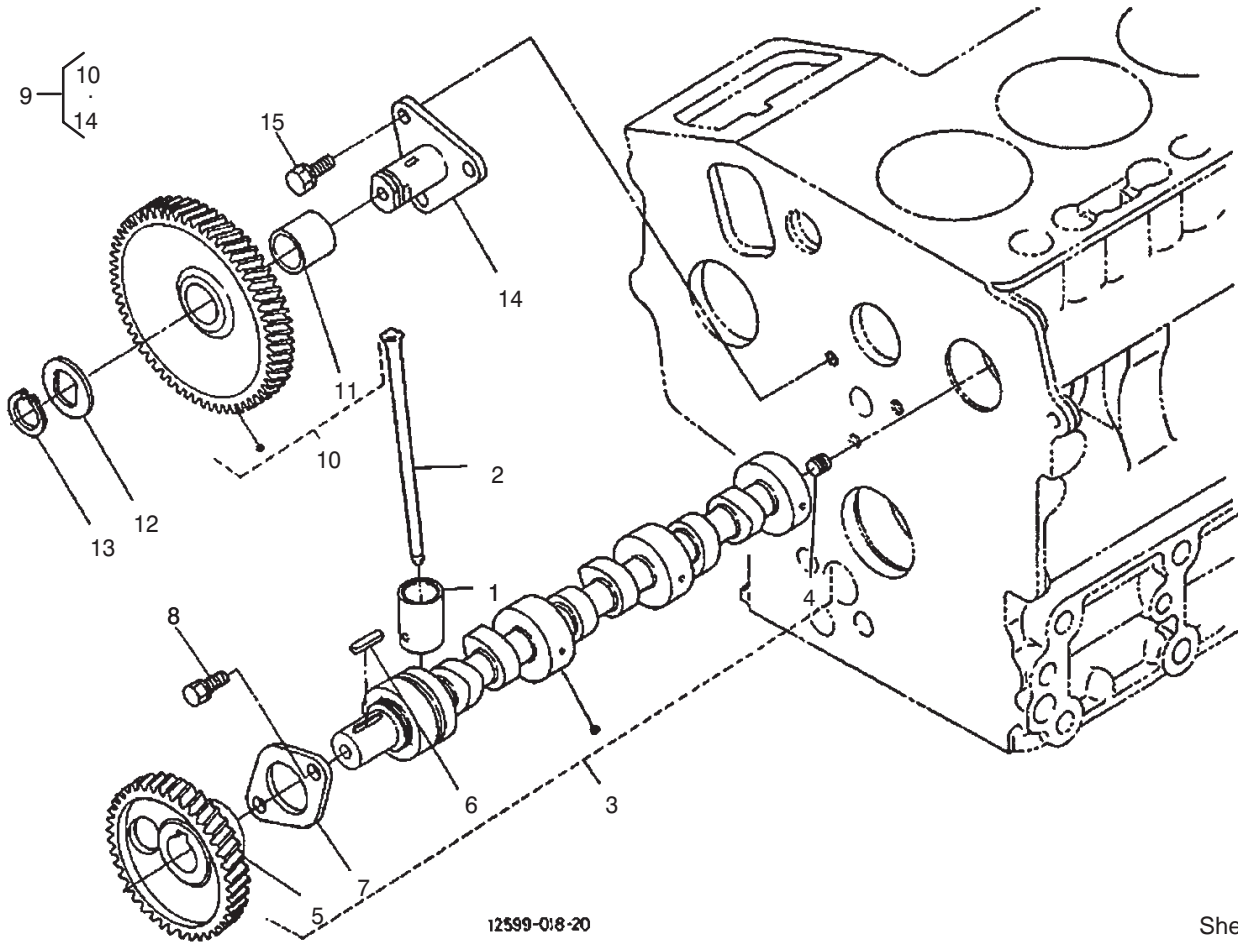

12599-018-20

Sheet No.:9

Camshaft Assembly

Ref. No.	Part No.	Qty.	Description
1	100-1990	6	Tappet
2	100-1989	6	Rod-Push
3	100-2162	1	Camshaft ASM
4	98-7449	1	Screw-Set
5	100-2163	1	Gear-Cam
6	98-9378	1	Key-Feather
7	100-1887	1	Camshaft-Stopper
8	98-9350	2	Bolt
9	100-2240	1	Ser/V Idle Gear ASM
10	100-1966	1	Gear-Idle, Comp.
11	100-1968	1	Bush
12	100-1970	1	Collar-Gear, Idle
13	100-1969	1	Ring-Snap
14	100-1967	1	Shaft-Gear, Idle
15	98-9351	3	Bolt

Ref. No.	Part No.	Qty.	Description

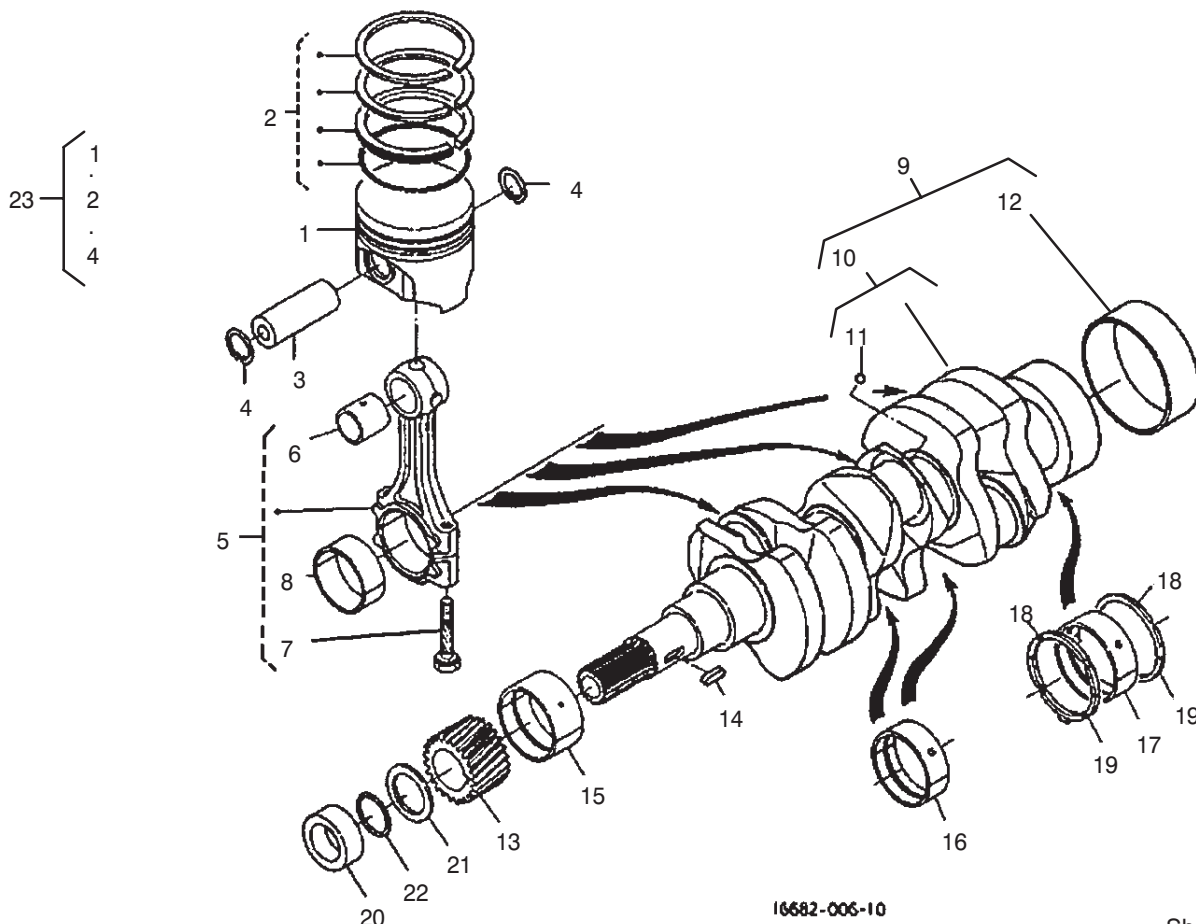

16682-006-10

Sheet No.:10

Piston and Crankshaft Assembly

Ref. No.	Part No.	Qty.	Description
1	100-1994	3	Piston (STD.)
1	100-1996	3	Piston (+0.25 Mm)
2	100-2158	3	Piston Ring ASM
2	100-2159	3	Piston Ring ASM
3	100-1995	3	Pin-Piston
4	100-1835	6	Cir-Cup, Piston Pin
5	100-1998	3	Connecting Rod ASM
6	100-1997	3	Bush-Pin, Piston
7	100-1999	6	Bolt-Rod, Connecting
8	100-1942	3	Crankpin-Metal (-0.2 Mm)
8	100-1943	3	Crankpin-Metal (-0.4 Mm)
8	100-2000	3	Crankpin-Metal (STD.)
9	100-2161	1	Crankshaft ASM
10	100-2160	1	Crankshaft-Comp.
11	100-1791	3	Ball
12	100-2054	1	Sleeve-Crankshaft
13	100-1891	1	Gear-Crankshaft
14	100-1752	1	Key-Feather
15	100-1944	1	Crankshaft-Metal (STD.)
15	100-1947	1	Crankshaft-Metal (-0.2 Mm)
15	100-1948	1	Crankshaft-Metal (-0.4 Mm)

Ref. No.	Part No.	Qty.	Description
16	100-1945	2	Crankshaft-Metal (-0.2 Mm Set)
16	100-1946	2	Crankshaft-Metal (-0.4 Mm Set)
16	100-2033	2	Crankshaft-Metal (STD. Set)
17	100-1870	1	Crankshaft-Metal (-0.2 Mm Set)
17	100-1871	1	Crankshaft-Metal (-0.4 Mm Set)
17	100-2032	1	Crankshaft-Metal (STD. Set)
18	100-1836	2	Metal-Side (STD.)
18	100-1838	2	Metal-Side (+0.2 Mm)
18	100-1839	2	Metal-Side (+0.4 Mm)
19	100-1837	2	Metal-Side (STD.)
19	100-1840	2	Metal-Side (+0.2 Mm)
19	100-1841	2	Metal-Side (+0.4 Mm)
20	100-1890	1	Collar-Crankshaft
21	100-1974	1	Slinger-Oil
22	100-2209	1	O-Ring
23	100-2164	1	Kit-Piston

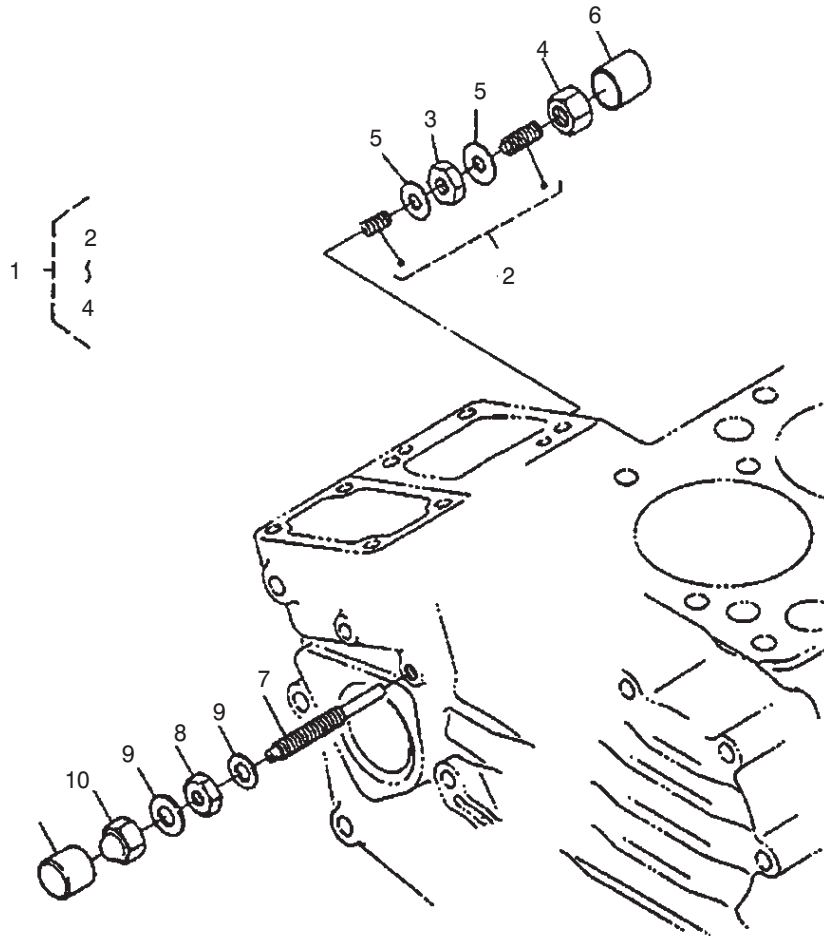

Sheet No.:13

Engine Stop Lever Assembly

Ref. No.	Part No.	Qty.	Description
1	100-1898	1	Idle Appartus ASM
2	100-1899	1	Adjusting Bolt ASM
3	100-1846	1	Nut
4	100-1901	1	Nut-Cap
5	98-7428	2	Gasket
6	100-1902	1	Cap
7	100-1900	1	Bolt-Adjusting
8	100-2175	1	Nut-Lock
9	98-7654	2	Gasket
10	98-9441	1	Nut-Cap

Ref. No.	Part No.	Qty.	Description

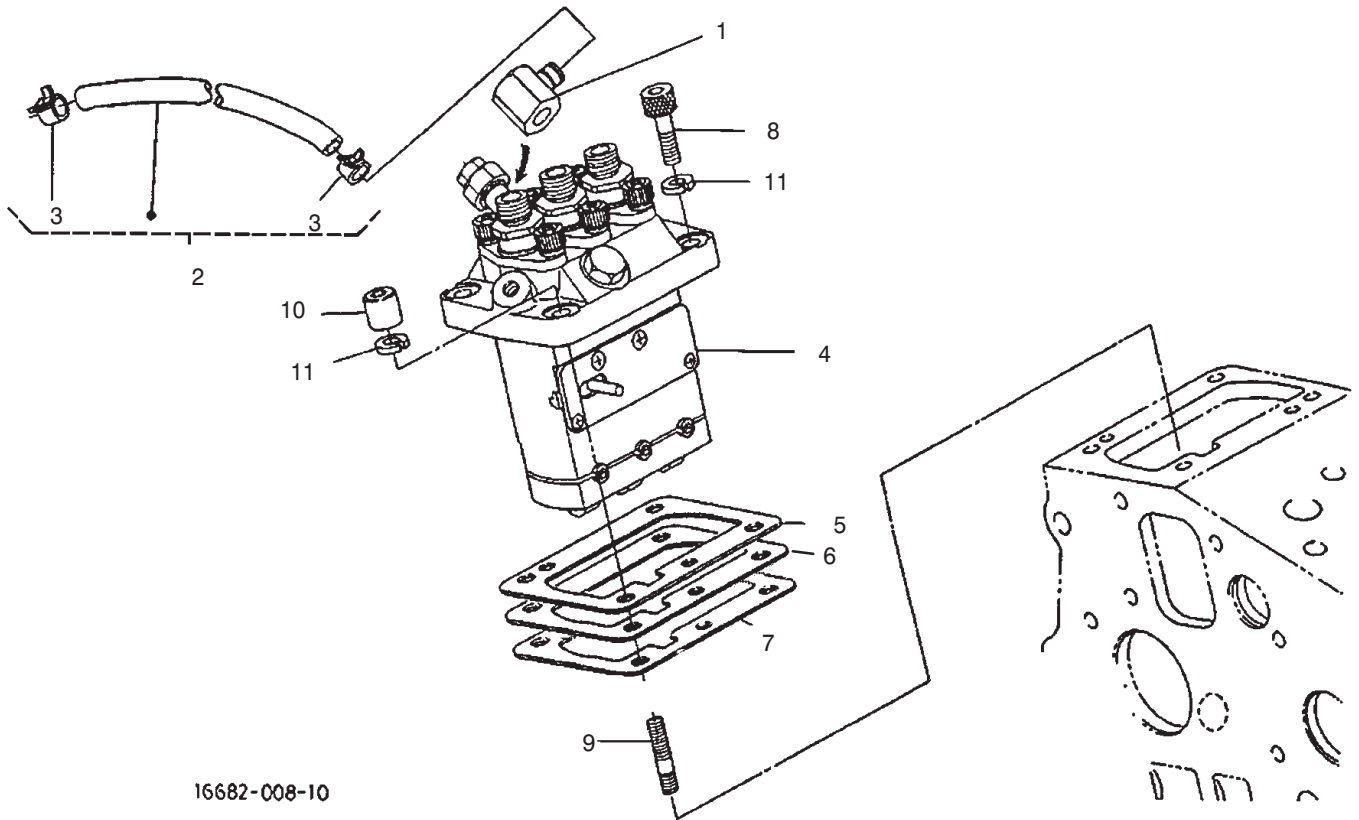

16682-008-10

Sheet No.:14

Injection Pump Assembly

Ref. No.	Part No.	Qty.	Description	Ref. No.	Part No.	Qty.	Description
1	100-1928	1	Joint-Eye				
2	100-1842	1	Fuel Pipe ASM				
3	100-2217	2	Clip-Pipe				
4	100-1759	1	Inj. Pump ASM				
5	98-9456	1	Shim (0.2mm)				
6	98-9457	1	Shim-Injection (0.25mm)				
7	98-9458	1	Shim-Injection (0.30mm)				
8	98-9361	2	Bolt-HSH				
9	98-9438	2	Stud				
10	98-9440	2	Nut-Cap				
11	98-9367	4	Washer-Spring				

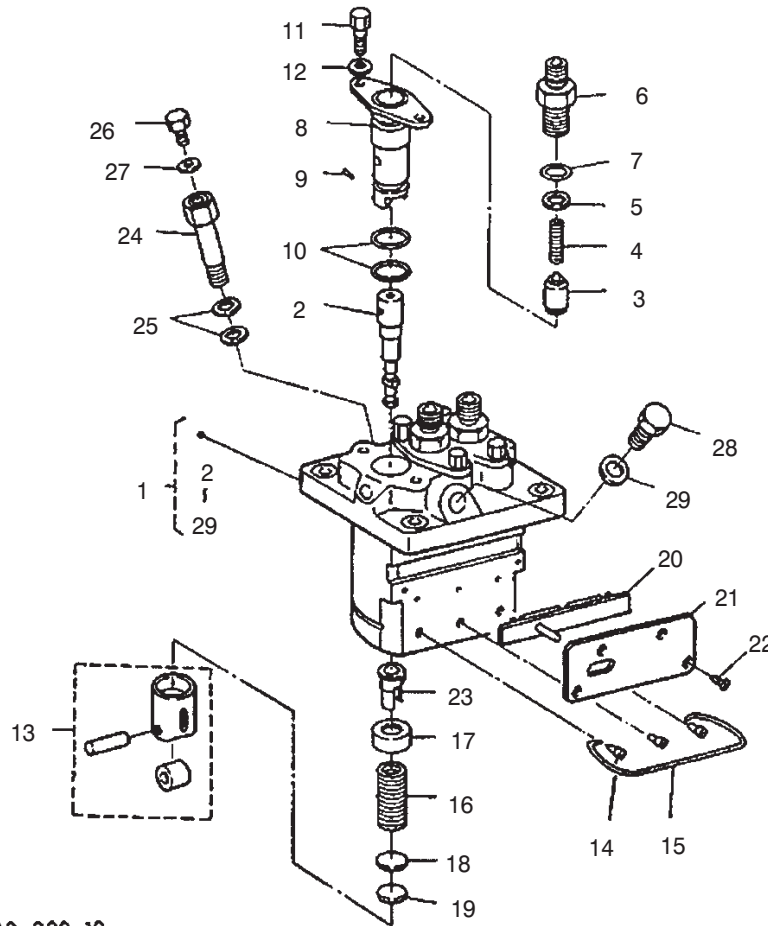

16689-009-10

Sheet No.:15

Injection Pump (Complete Parts)

Ref. No.	Part No.	Qty.	Description
1	100-1759	1	Inj. Pump ASM
2	100-2005	3	Plunger-Pump
3	98-9421	3	Valve-Delivery
4	98-9424	3	Spring-Valve, Delivery
5	98-9425	3	Gasket-Valve, Delivery
6	100-2007	3	Holder-Valve, Deliv.
7	98-9447	3	O-Ring
8	98-9434	3	Flange-Sleeve
9	98-9443	3	Pin-Joint
10	100-1895	6	O-Ring
11	98-9452	6	Screw
12	100-1931	6	Washer
13	98-9422	3	Tappet ASM
14	98-9426	3	Pin-Guide, Tappet
15	98-9450	1	Pin-Clamp
16	98-9428	3	Spring-Plunger
17	98-9427	3	Seat-Spring, Upper
18	98-9429	3	Seat-Spring, Lower
19	98-9433	3	Shim
20	100-1949	1	Rack-Control
21	100-1950	1	Plate
22	98-9442	4	Screw
23	98-9432	3	Sleeve-Control
24	100-1896	1	Screw-Hollow
25	98-9445	2	Gasket

Ref. No.	Part No.	Qty.	Description
26	98-9430	1	Screw
27	98-9446	1	Gasket
28	100-1953	1	Bolt
29	98-9451	1	Gasket

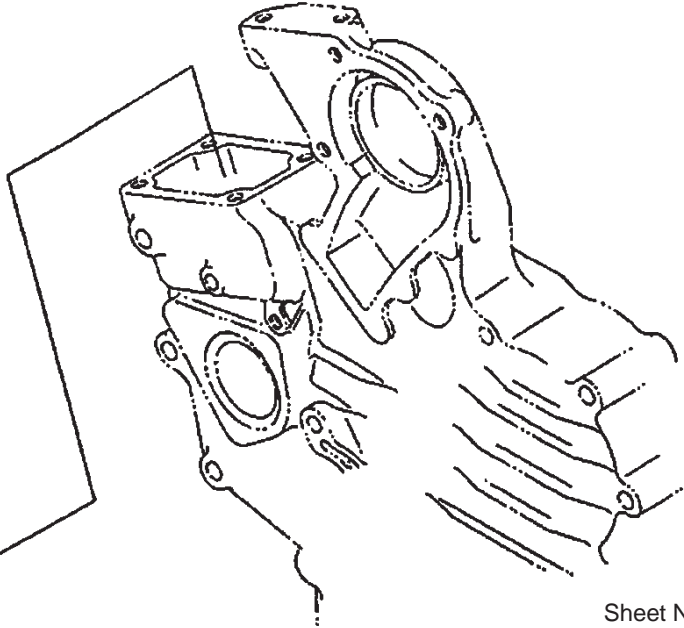
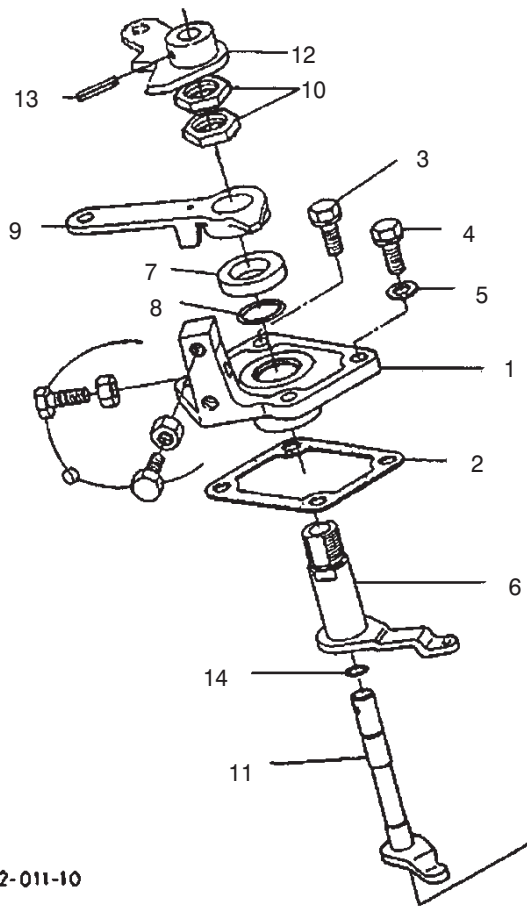

16682-011-10

Sheet No.:17

Speed Control Plate Assembly

Ref. No.	Part No.	Qty.	Description
1	100-1912	1	Plate-Speed, Cont.
2	100-1914	1	Gasket
3	98-7605	2	Bolt
4	100-1769	2	Bolt
5	98-7654	2	Gasket
6	100-2172	1	Lever-Governor
7	100-1915	1	Collar
8	100-2208	1	O-Ring
9	100-1986	1	Lever-Cont., Speed
10	100-1925	2	Nut
11	100-2050	1	Shaft-Lever
12	100-2173	1	Lever-Stop, Engine
13	100-1751	1	Pin-Spring
14	100-2207	1	O-Ring

Ref. No.	Part No.	Qty.	Description

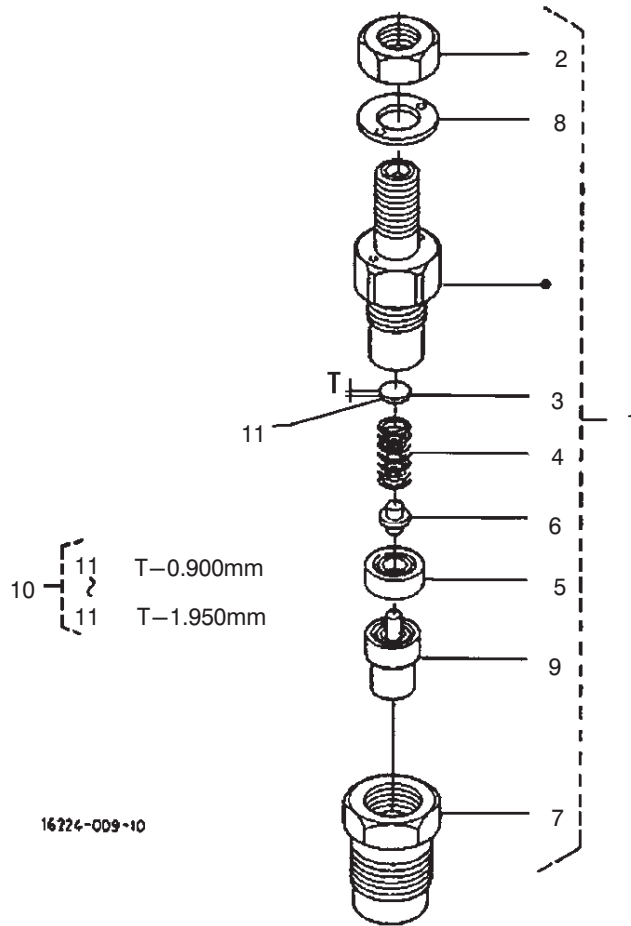

Sheet No.:19

Nozzle Holder (Complete Parts)

Ref. No.	Part No.	Qty.	Description
1	100-1758	3	Nozzle Holder ASM
2	98-7613	3	Nut
3	98-7642	3	Washer-Adjusting
4	98-7647	3	Spring-Nozzle
5	98-7665	3	Piece-Distant
6	98-7666	3	Rod-Push
7	100-2242	3	Nut-Nozzle
8	98-7668	3	Washer
9	100-2009	3	Piece-Nozzle
10	98-9448	3	Adj Washer ASM
11	98-7642	3	Washer-Adjusting
11	98-7841	3	Washer-Adjusting
11	98-7842	3	Washer-Adjusting
11	98-7843	3	Washer-Adjusting
11	98-7844	3	Washer-Adjusting
11	98-7845	3	Washer-Adjusting
11	98-7846	3	Washer-Adjusting
11	98-7847	3	Washer-Adjusting
11	98-7848	3	Washer-Adjusting
11	98-7849	3	Washer-Adjusting
11	98-7850	3	Washer-Adjusting
11	98-7851	3	Washer-Adjusting
11	98-7852	3	Washer-Adjusting
11	98-7853	3	Washer-Adjusting
11	98-7854	3	Washer-Adjusting
11	98-7855	3	Washer-Adjusting

Ref. No.	Part No.	Qty.	Description
11	98-7856	3	Washer-Adjusting
11	98-7857	3	Washer-Adjusting
11	98-7858	3	Washer-Adjusting
11	98-7859	3	Washer-Adjusting
11	98-7860	3	Washer-Adjusting
11	98-7861	3	Washer-Adjusting
11	98-7862	3	Washer-Adjusting
11	98-7863	3	Washer-Adjusting
11	98-7864	3	Washer-Adjusting
11	98-7865	3	Washer-Adjusting
11	98-7866	3	Washer-Adjusting
11	98-7867	3	Washer-Adjusting
11	98-7868	3	Washer-Adjusting
11	98-7869	3	Washer-Adjusting
11	98-7870	3	Washer-Adjusting
11	98-7871	3	Washer-Adjusting
11	98-7872	3	Washer-Adjusting
11	98-7873	3	Washer-Adjusting
11	98-7874	3	Washer-Adjusting
11	98-7875	3	Washer-Adjusting
11	98-7876	3	Washer-Adjusting
11	98-7877	3	Washer-Adjusting
11	98-7878	3	Washer-Adjusting
11	98-7879	3	Washer-Adjusting
11	98-7880	3	Washer-Adjusting
11	98-7881	3	Washer-Adjusting

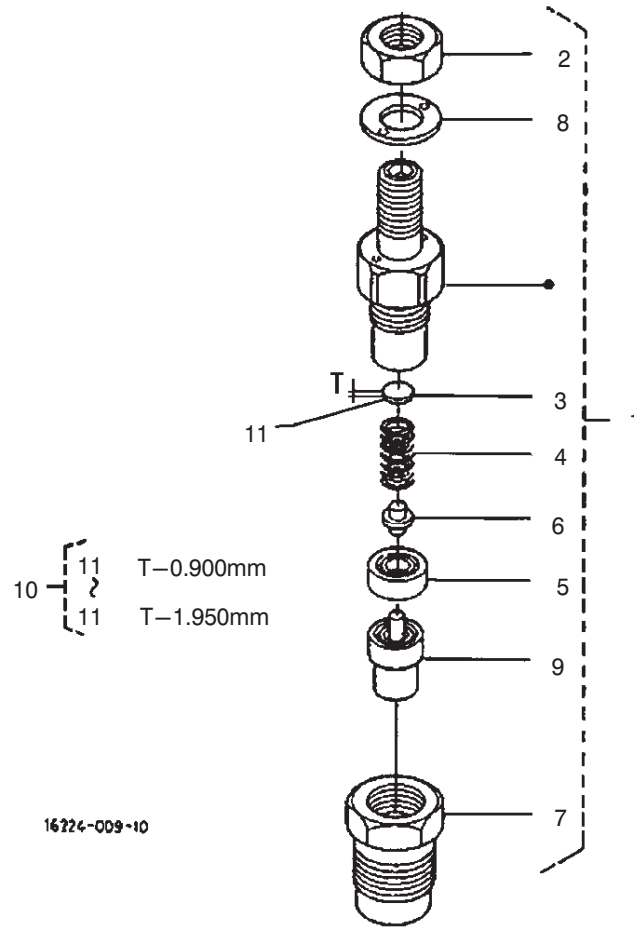

Sheet No.:19

Nozzle Holder (Complete Parts Continued)

Ref. No.	Part No.	Qty.	Description
11	98-7882	3	Washer-Adjusting

Ref. No.	Part No.	Qty.	Description

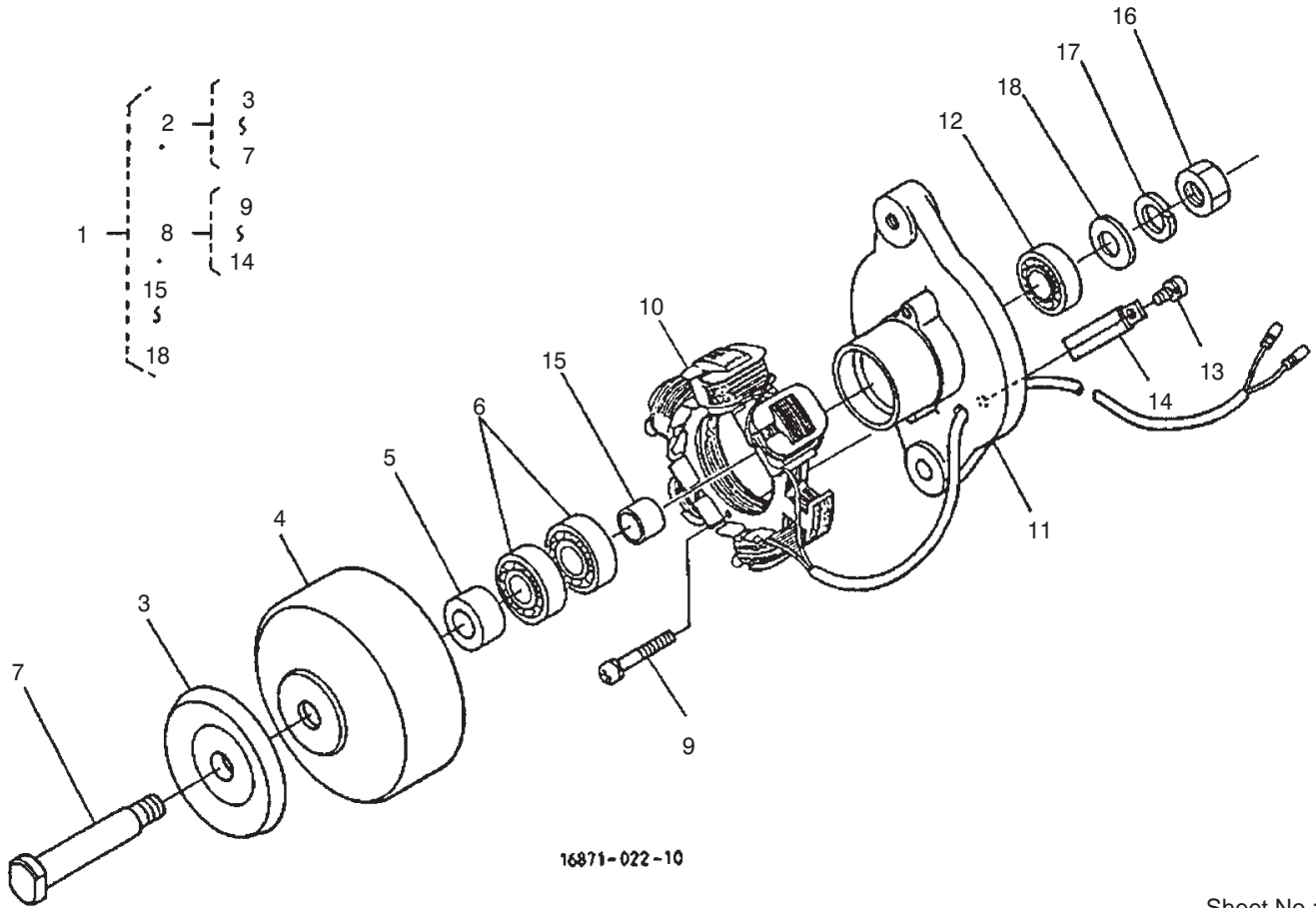

16871-022-10

Sheet No.:22

Dynamo (Complete Parts)

Ref. No.	Part No.	Qty.	Description
1	100-2168	1	Dynamo ASM
2	100-1862	1	Rotor-Comp.
3	100-2228	1	Pulley
4	100-1860	1	Rotor
5	100-2184	1	Collar
6	100-1756	2	Bearing-Ball
7	100-1867	1	Shaft-Fan
8	100-1866	1	Stator-Comp.
9	100-1848	2	Screw-Head, Round
10	100-1865	1	Stator
11	100-1861	1	Plate
12	100-1756	1	Bearing-Ball
13	100-1868	1	Screw-Head, Round
14	100-1864	1	Clamp-Cord
15	100-1844	1	Collar
16	100-1847	1	Nut
17	100-1850	1	Washer-Spring
18	100-1849	1	Washer-Plain

Ref. No.	Part No.	Qty.	Description

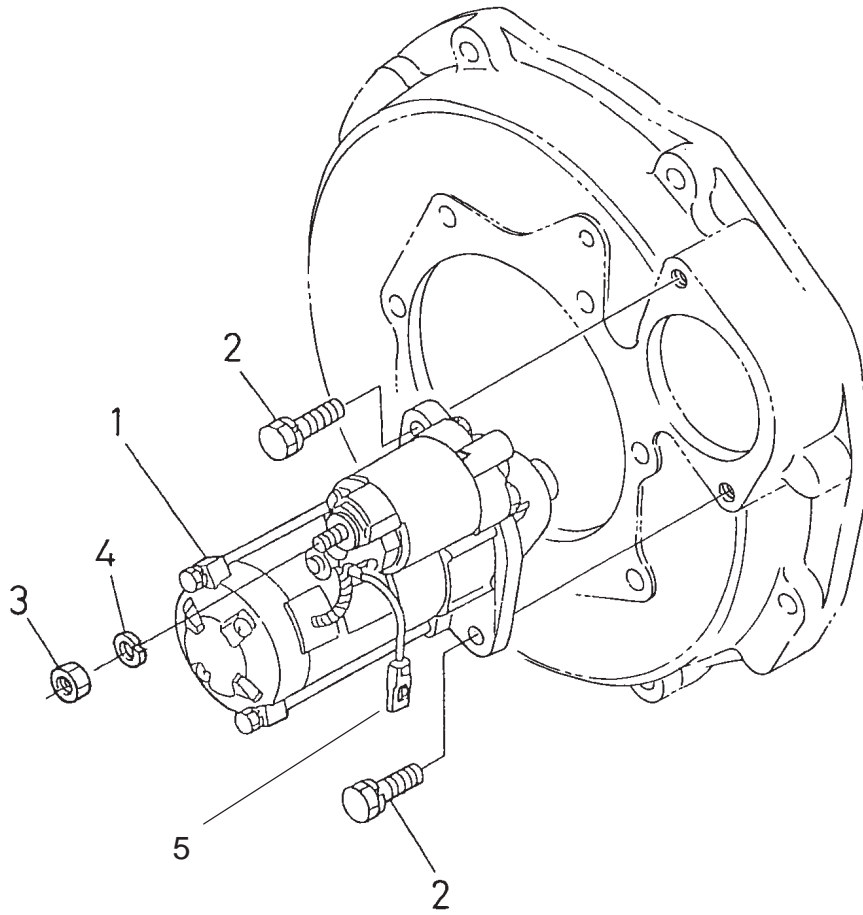

1G299-085-10

Sheet No.:23

Starter Assembly

Ref. No.	Part No.	Qty.	Description
1	100-2179	1	Starter ASM
2	98-7438	2	Bolt
3	98-7739	1	Nut
4	98-7535	1	Washer-Spring
5	99-1434	1	Wire-Lead

Ref. No.	Part No.	Qty.	Description

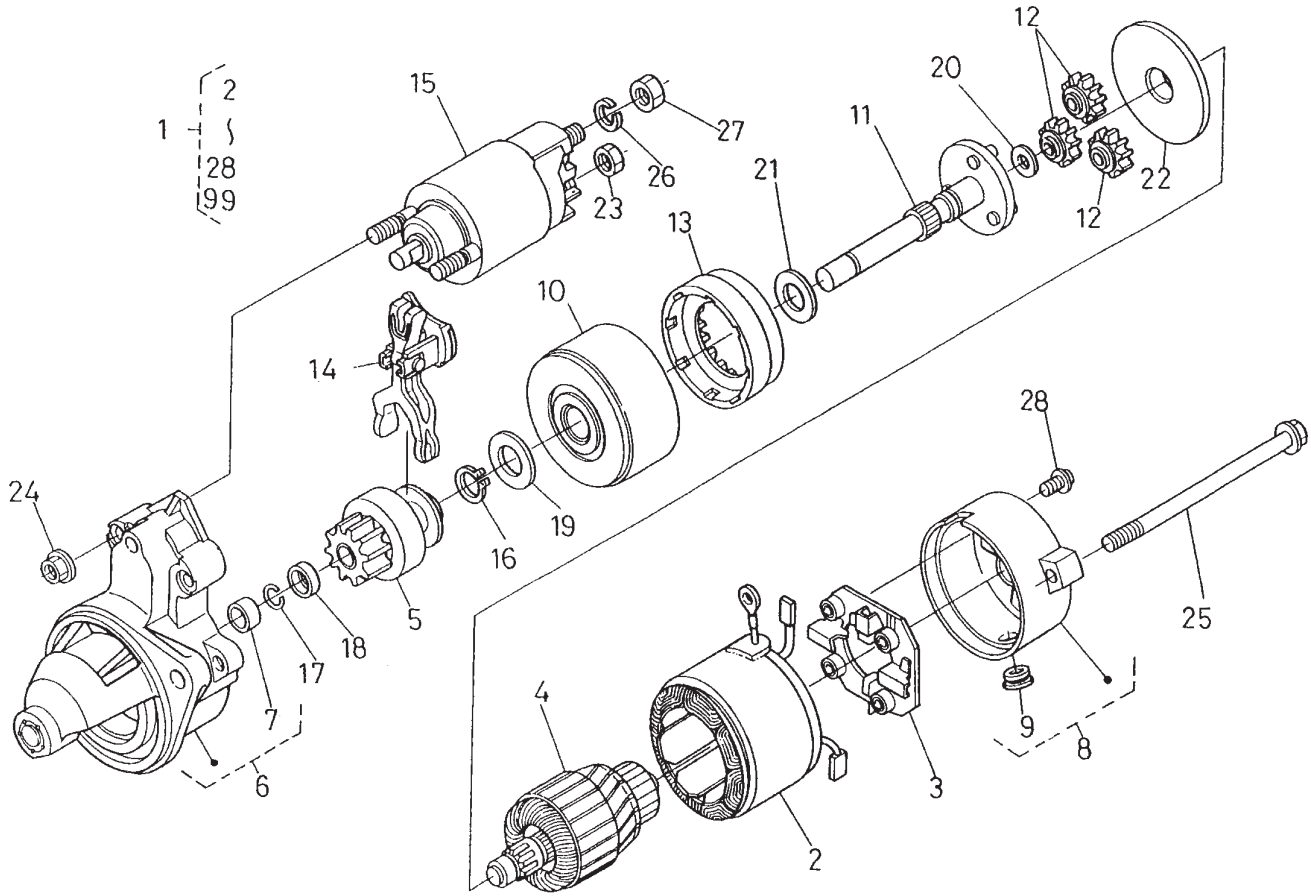

67992-001-10

Sheet No.:24

Starter (Complete Parts)

Ref. No.	Part No.	Qty.	Description
1	100-2179	1	Starter ASM
2	100-2181	1	Starter Yoke ASM
3	100-2222	1	Holder ASM
4	100-2182	1	Armature ASM
5	100-2185	1	Starter Clutch ASM
6	100-2180	1	Starter Housing ASM
7	100-2183	1	Bearing
8	100-2186	1	Frame ASM
9	100-2213	1	Cover
10	100-2223	1	Bearing ASM
11	100-2187	1	Starter Shaft ASM
12	100-2220	3	Gear
13	100-2221	1	Gear
14	100-2218	1	Lever
15	100-2211	1	Magnetic Switch ASM
16	100-2219	1	Ring-Snap
17	100-2212	1	Ring-Snap
18	100-2216	1	Collar
19	100-2224	1	Washer-Plain
20	100-2225	1	Washer-Plain
21	100-2226	1	Washer-Plain
22	100-2227	1	Plate
23	100-2243	1	Nut-Hexagon
24	100-1813	2	Nut
25	100-2210	2	Bolt-Through
26	100-2215	1	Washer-Spring

Ref. No.	Part No.	Qty.	Description
27	100-2171	1	Nut-Hexagon
28	100-2188	2	Screw
99	99-1434	1	Wire-Lead

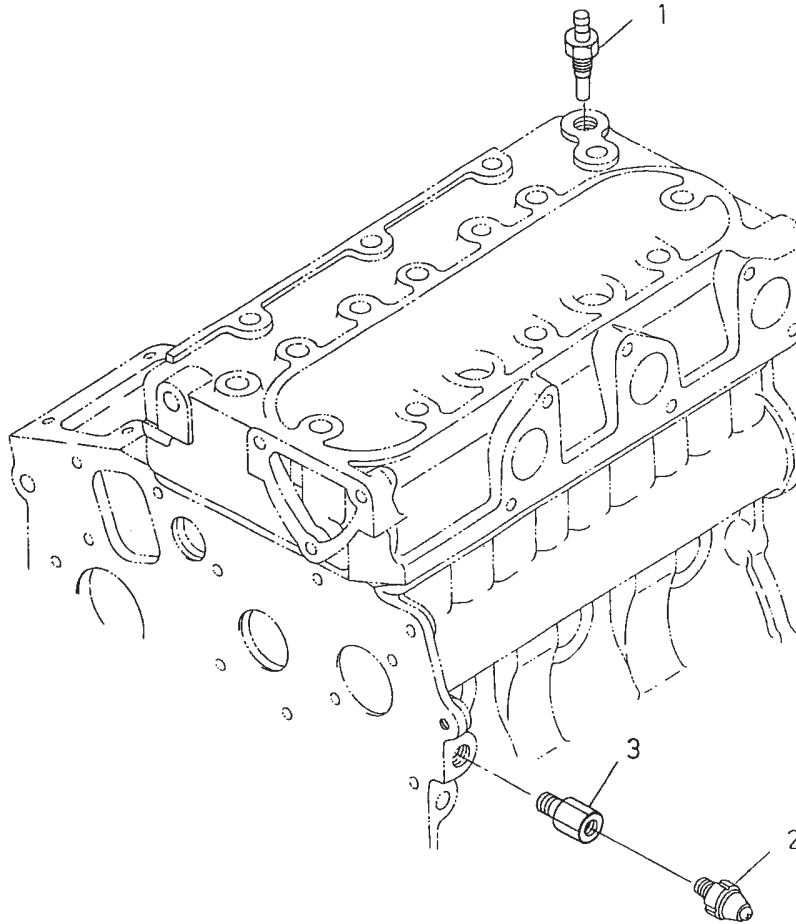

1G299-086-10

Sheet No.:25

Oil Switch and Thermostat Assembly

Ref. No.	Part No.	Qty.	Description
1	99-3582	1	Thermostat
2	98-7764	1	Switch-Oil
3	100-2170	1	Holder-Signal, Oil

Ref. No.	Part No.	Qty.	Description

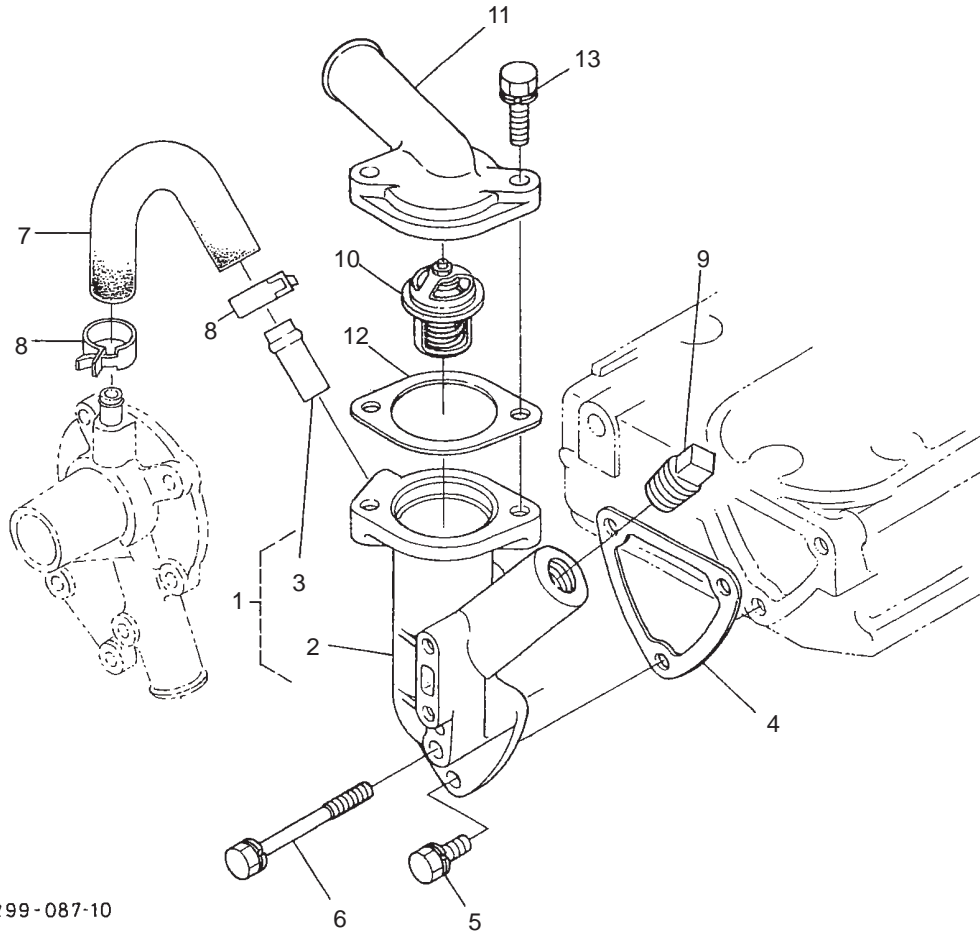

1G299-087-10

Sheet No.:26

Water Flange and Thermostat Assembly

Ref. No.	Part No.	Qty.	Description
1	100-2165	1	Flange-Water, Comp.
2	100-2166	1	Flang-Water
3	98-9580	1	Pipe-Return, Water
4	100-1919	1	Gasket-Flange, Water
5	98-7692	2	Bolt
6	100-2201	1	Bolt
7	100-2017	1	Pipe-Return, Water
8	98-9579	2	Band-Pipe
9	100-2169	1	Plug
10	100-2053	1	Thermostat ASM
11	100-2231	1	Cover-Thermostat
12	100-2157	1	Gasket-Thermostat
13	98-9353	2	Bolt

Ref. No.	Part No.	Qty.	Description

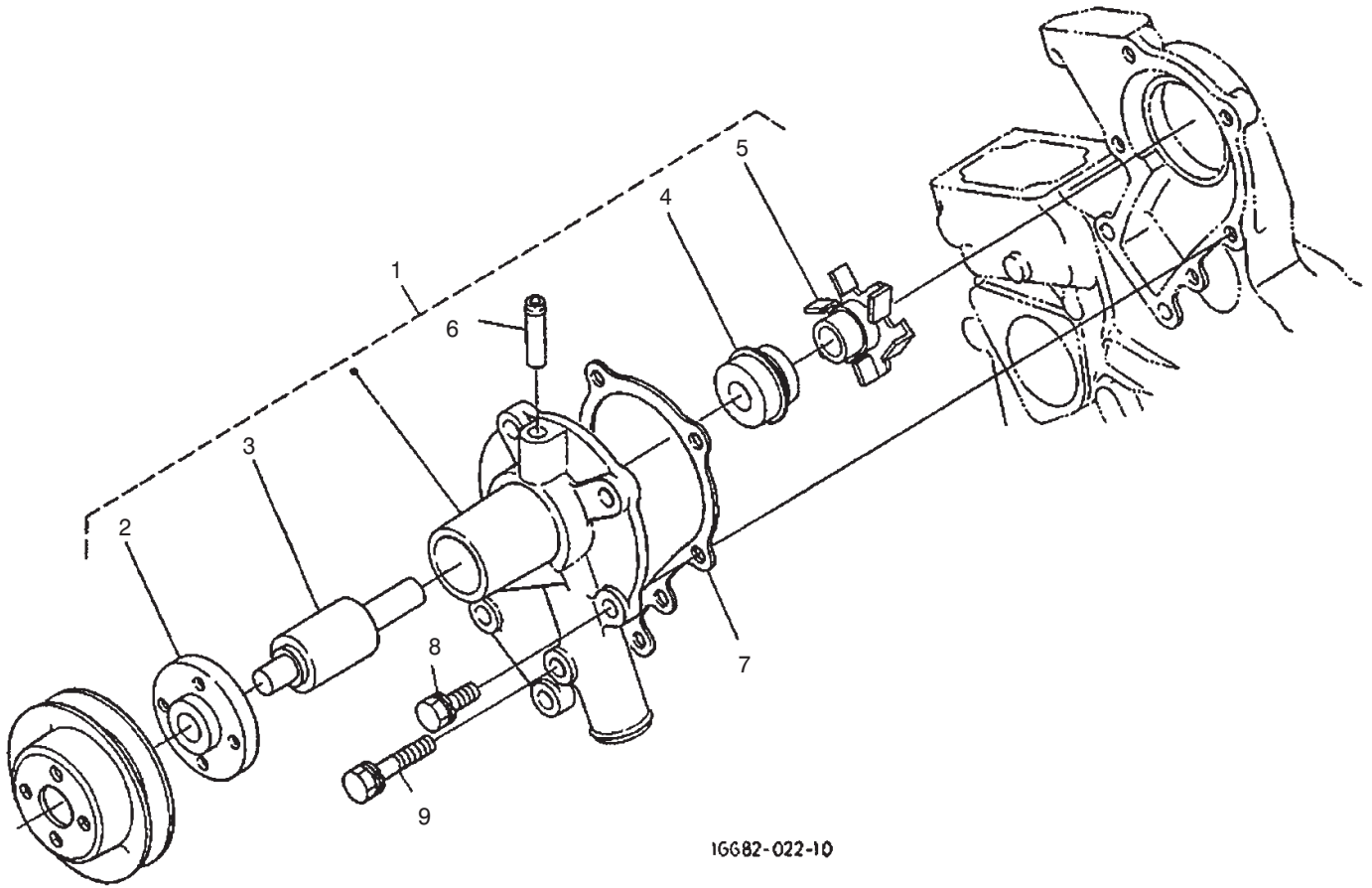

16682-022-10

Sheet No.:27

Water Pump Assembly

Ref. No.	Part No.	Qty.	Description
1	100-2065	1	Water Pump ASM
2	100-1933	1	Flange-Pump, Water
3	100-1934	1	Bearing-Ball
4	99-3518	1	Water Pump Seal ASM
5	100-2067	1	Impeller-Pump, Water
6	100-1932	1	Pipe-Return, Water
7	100-1976	1	Gasket-Pump, Water
8	100-1750	4	Bolt
9	100-1764	1	Bolt

Ref. No.	Part No.	Qty.	Description

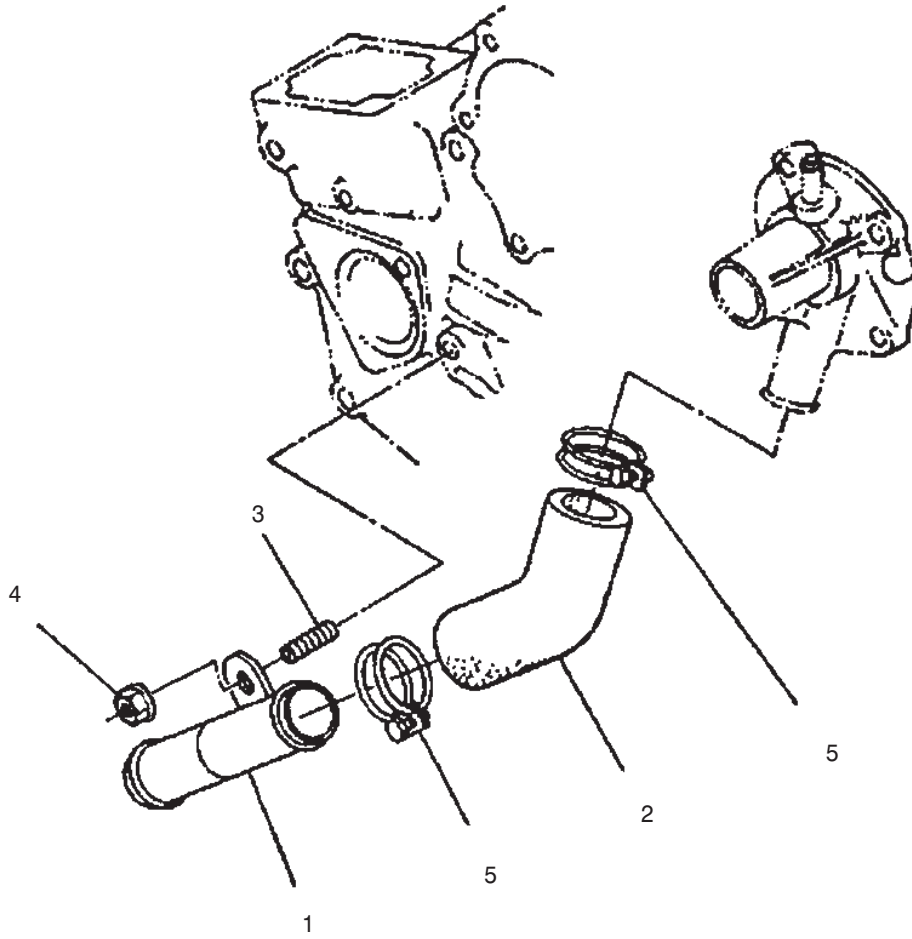

Sheet No.:28

Water Pipe Assembly

Ref. No.	Part No.	Qty.	Description
1	100-1918	1	Pipe-Water
2	100-1975	1	Pipe-Water
3	100-1924	1	Stud
4	100-2203	1	Nut-Flange
5	100-1753	2	Clamp-Hose

Ref. No.	Part No.	Qty.	Description

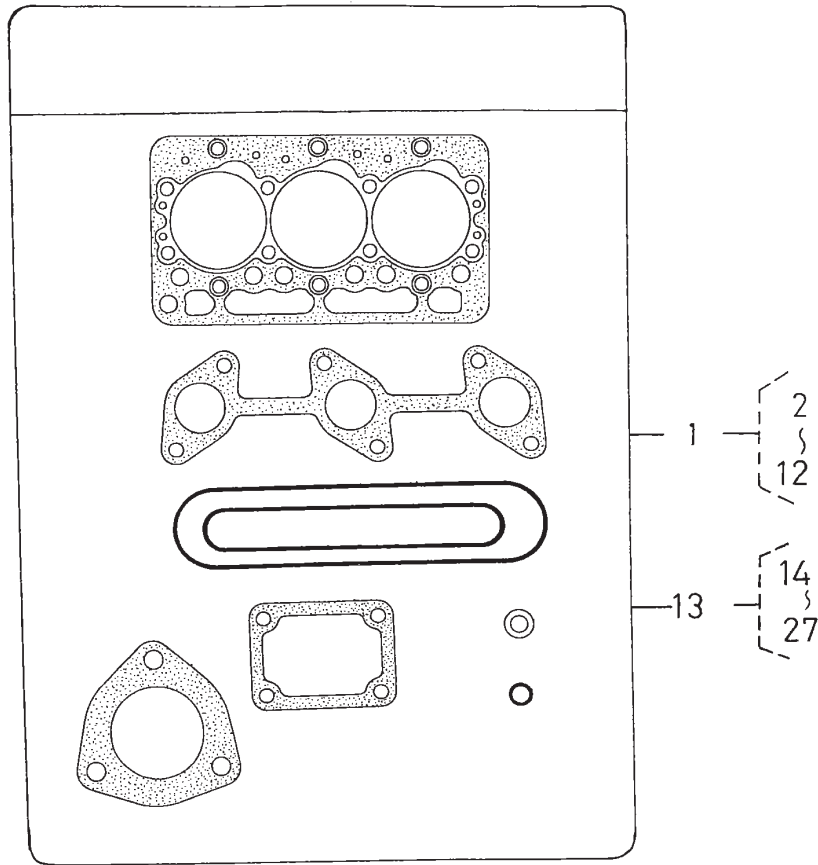

19449-018-10

Sheet No.:32

Gasket Kit

Ref. No.	Part No.	Qty.	Description
1	100-2176	1	Kit-Gasket, Upper
2	98-7509	1	O-Ring
3	100-2043	1	Gasket-Head, Cylinder
4	100-1937	1	Gasket-In-Manifold
5	100-1957	1	Gasket
6	100-1797	6	Seal-Stem, Valve
7	100-2030	1	Gasket-Cover, Head
8	98-7654	3	Gasket
9	99-3446	1	O-Ring
10	100-1919	1	Gasket-Flange, Water
11	100-2157	1	Gasket-Thermostat
12	100-2238	1	Gasket-Muffler
13	100-2174	1	Kit-Gasket, Lower
14	100-1976	1	Gasket-Pump, Water
15	100-1954	1	Gasket-Case, Gear
16	100-2206	3	O-Ring
17	100-1929	1	Gasket-Case, Bearing
18	100-1876	1	Gasket-Case, Bearing
19	100-2209	1	O-Ring
20	100-2205	1	O-Ring
21	100-2003	1	Gasket-Pump, Oil
22	98-9636	1	Gasket-Pump, Fuel
23	100-2061	1	Gasket-Gearcase, H/M
24	100-1914	1	Gasket

Ref. No.	Part No.	Qty.	Description
25	98-7428	2	Gasket
26	100-2208	1	O-Ring
27	100-2207	1	O-Ring

