



1800 Power Curve[®]

Snowthrower

Model No. 38025—200000001 and Up

Operator's Manual

Contents

	Page
Introduction	2
Safety	2
Safe Operating Practices	3
Safety and Instruction Decals	5
Assembly	5
Installing the Upper Handle and Chute Crank	5
Installing the Discharge Chute	6
Before Starting	7
Unlocking the Snowthrower	7
Securing the Power Supply Cord	7
Operation	8
Before Operating	8
Starting and Stopping	8
Operating Tips	8
Maintenance	10
Lubricating the Snowthrower	10
Replacing the Scraper	10
Replacing the Rotor	10
Replacing the Large Belt	11
Replacing the Small Belt	12
Storage	13
Toro Service Support	13
Warranty	Back Cover

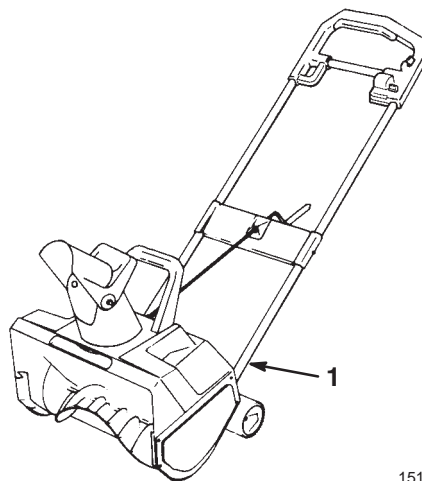

1516

Figure 1

1. Model number and serial number decal

Write the product model number and serial number in the space below:

<p>Model No. _____</p> <p>Serial No. _____</p>
--

Introduction

Thank you for choosing a Toro product. We want you to be completely satisfied with your new purchase.

Read this manual carefully to learn how to operate and maintain your product properly. The information in this manual can help you and others avoid injury and product damage. Although Toro designs and produces safe products, you are responsible for operating the product properly and safely.

Whenever you contact your Authorized Service Dealer or the factory for help with service, genuine Toro parts, or additional information, have the model number and the serial number of your product handy. You will find the model number and serial number decal on the product as illustrated in Figure 1.

This manual identifies potential hazards and has special safety messages that help you and others avoid personal injury and even death. **DANGER**, **WARNING**, and **CAUTION** are words used to identify the level of hazard.

DANGER signals an extreme hazard that will cause serious injury or death if you do not follow the recommended precautions.

WARNING signals a hazard that may cause serious injury or death if you do not follow the recommended precautions.

CAUTION signals a hazard that may cause minor or moderate injury if you do not follow the recommended precautions.

This manual uses two other words to highlight information. **Important** calls attention to special mechanical information and **Note** emphasizes general information worthy of special attention.

Safety

To assure maximum safety, best performance, and to gain knowledge of the product, it is essential that you or any other operator of the snowthrower read and understand the contents of this manual before the motor

is ever started. Pay particular attention to the safety alert symbol  which means CAUTION, WARNING OR DANGER — “personal safety instruction.” Read and understand the instruction because it has to do with safety. FAILURE TO COMPLY WITH INSTRUCTION MAY RESULT IN PERSONAL INJURY.

Safe Operating Practices

IMPORTANT: Always follow all safety instructions to avoid serious injury or death.

General Operation

- Read this manual carefully before operating the snowthrower. Become familiar with the controls and proper use of the snowthrower. Never allow children under 16 years of age to operate the snowthrower. Never allow adults to operate snowthrower without proper instructions.
- The operator of the snowthrower is responsible for keeping everyone, especially children and pets, away from area of operation. The operator is responsible for accidents or hazards occurring to other people or their property. Always direct discharge chute away from people.
- Thoroughly inspect area where snowthrower will be used and remove doormats, sleds, boards, sticks, stones, wire and debris. Watch for foreign objects while snowthrowing.
- Wear adequate winter clothing and rubber boots that will ensure proper footing on slippery surfaces. Do not wear loose-fitting clothing that could possibly get caught in moving parts.
- Keep all shields and safety devices in place. If a shield, safety device or decal is illegible, damaged or lost, repair or replace it before beginning operation. Also, tighten any loose nuts, bolts or screws.
- Do not use snowthrower on gravel or crushed rock surfaces. Flying debris may cause damage or personal injury.
- **WARNING** - To prevent electric shock, use only a UL-approved extension cord suitable for outdoor use in cold temperatures (refer to page 7 for proper size and use). Replace a damaged extension cord immediately.
- To reduce the risk of electric shock, this appliance has a polarized plug (one blade is wider than the other) (Fig. 8) and will require the use of a polarized extension cord. The appliance plug will fit into a polarized extension cord only one way. If the plug does not fit fully into the extension cord, reverse the plug. If the plug still does not fit, obtain a correct polarized extension cord. A polarized extension cord will require the use of a polarized wall outlet. This plug will fit into the polarized wall outlet only one way. If the plug does not fit fully into the wall outlet, reverse the plug. If the plug still does not fit, contact a qualified electrician to install the proper wall outlet. Do not change the equipment plug, extension cord receptacle, or extension cord plug in any way.

- To prevent disconnection of snowthrower cord from extension cord during operation, tie extension cord to loop in upper handle before connecting to snowthrower; refer to Figure 7 on page 7 for proper procedures.

While Operating

- Keep people and pets a safe distance away from the snowthrower and area of operation.
- Avoid accidental starting. Don't carry plugged in snowthrower with hand on control bar. Keep away from control bar while plugging in cord.
- If the extension cord is damaged in any manner while plugged in, remove extension cord from wall receptacle.
- Do not abuse extension cord. Never carry snowthrower by cord or pull sharply on cord to disconnect from receptacle. Keep cord away from heat, oil and sharp edges.
- Always keep extension cord away from rotating parts to prevent damage and electric shock.
- Operate the snowthrower only when there is good visibility or light. Always maintain secure footing and balance, and keep a firm grip on the handle. Do not overreach.
- Do not use snowthrower on a roof.
- Be attentive when using the snowthrower, and stay alert for holes in the terrain and other hidden hazards.
- **Stay away from discharge opening while operating the snowthrower.** Keep face, hands, feet, and any other part of your body or clothing away from concealed, moving or rotating parts.
- Never operate snowthrower near bystanders, glass enclosures, automobiles, trucks, window wells or a drop-off without proper adjustment of the snow discharge angle; refer *Operating Tips* on page 8 for correct operating procedure.
- Clear snow from slopes by going up and down, never across the face. Use caution when changing directions. Never clear snow from steep slopes.

- Operation of the snowthrower in the hand-held position (wheels off the ground) is unsafe except when used in accordance with special instructions in the *Operator's Manual*. Refer to *Operating Tips* on page 8.
- When using the secondary handle, always turn chute in the opposite direction from where you are standing.
- Do not force chute deflector too far forward. A gap will occur between chute and chute deflector which will allow snow and anything that may be picked up by snowthrower to fly in the direction of the operator.
- Do not overload the snowthrower by clearing snow at too fast a rate. Let the snowthrower do the work.
- If a solid object is hit or snowthrower vibrates abnormally, stop snowthrower and wait for all movement to stop. Disconnect extension cord and check snowthrower immediately for possible damage, an obstruction, debris in rotor or loose parts. Vibration is generally a sign of trouble. Repair any damage before operating snowthrower again.
- Before adjusting, cleaning, repairing or inspecting the snowthrower, or before unclogging the discharge chute, stop snowthrower by releasing the control bar and wait for all moving parts to stop. Also, disconnect cord from receptacle to prevent accidental starting.
- When through using snowthrower, let it run for a few minutes so ice does not freeze moving parts.
- Disconnect extension cord from cord receptacle, turn key clockwise and remove key from handle if snowthrower will be left unattended.

replacement parts and accessories to keep your Toro all Toro. **Never use “will fit” replacement parts and accessories.**

Maintenance

- Perform only those maintenance instructions described in this manual. Disconnect cord from receptacle before performing maintenance procedures to prevent the possibility of accidental starting. If major repairs are ever needed, contact your local Authorized Service Dealer or Toro Service Center for assistance.
- Keep the snowthrower in safe operating condition by keeping nuts, bolts and screws tight. Check all fasteners frequently to assure they are tight.
- Store snowthrower indoors when not in use in a dry, locked-up place out of reach of children. Remove extension cord from snowthrower and store with snowthrower to prevent misplacement. Lock snowthrower and remove key from handle. Store key in a memorable place.
- At the time of manufacture, the snowthrower conformed to and exceeded safety standards in effect for snowthrowers. Therefore, to assure best performance and safety, purchase genuine Toro

Safety and Instruction Decals



Safety decals and instructions are easily visible to the operator and are located near any area of potential danger. Replace any decal that is damaged or lost.

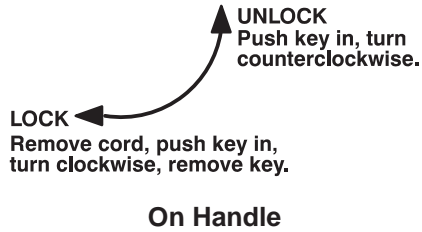

On Rear of Shroud

 **DOUBLE INSULATED** — When servicing, use only identical replacement parts.

Read operator's manual for operating and safety instructions. Replacement manual available by sending model and serial numbers to the TORO CO. 8111 Lyndale Av. S., Mpls, MN 55420

! DANGER

AVOID INJURY! FROM ROTOR/IMPELLER.
 KEEP HANDS, FEET AND CLOTHING AWAY FROM DISCHARGE AREA.
 DO NOT STEP IN FRONT OF MACHINE, OR USE HANDS TO UNBLOCK CHUTE.
 STOP MOTOR AND UNPLUG CORD BEFORE UNBLOCKING SNOW OR DEBRIS.
 DO NOT DIRECT DISCHARGE AT OTHERS. USE FOR SNOW REMOVAL ONLY.
 TO PREVENT ELECTRIC SHOCK, REPLACE DAMAGED CORD IMMEDIATELY.

 LISTED SNOW MOVER 546X

TORO 1800

MODEL 38025

120 VAC 60 HZ 12 AMP

**On Rear of Shroud
(Part No. 73-0450)**

Assembly

Note: Determine the left and right hand sides of the snowthrower by standing in the normal operating position.

Installing the Upper Handle and Chute Crank

1. Stand the snowthrower on its wheels and position the upper handle. Inspect the open internal wiring. If it is damaged, do not assemble. Contact your Authorized Service Dealer.

! CAUTION

POTENTIAL HAZARD

- Internal wiring could be damaged during assembly.

WHAT CAN HAPPEN

- Damaged wiring can cause serious personal injury when operating the snowthrower.

HOW TO AVOID THE HAZARD

- Use care so that the electrical wiring will not be damaged during assembly.
- If wiring is damaged, do not assemble the snowthrower. Contact your Authorized Service Dealer.

- Carefully insert the right side of the upper tubing **over** the end of the lower right side tubing (Fig. 2).
- Carefully insert the left side of the upper tubing **into** the end of the lower left side tubing (Fig. 2).
- Squeeze the upper tubes together, and wiggle the upper tubes down until the mounting holes in the upper and lower tubing line up (Fig. 2).

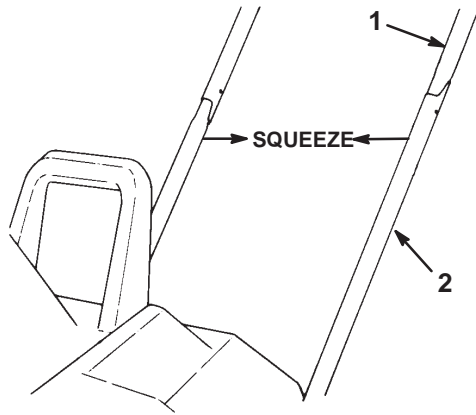

1531

Figure 2

- Upper tubing
- Lower tubing

- Place the mounting plate over the tubes (Fig. 3). Align the mounting plate holes with the upper and lower tubing holes.

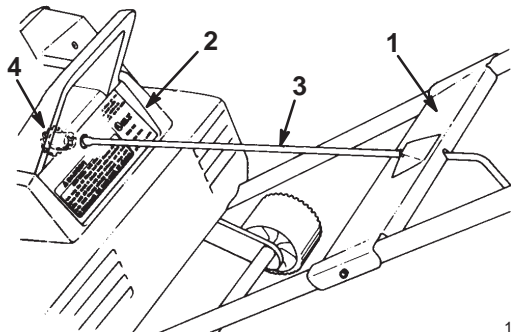

1532

Figure 3

- Mounting plate
- Shroud
- Chute crank
- Gear

- Insert the end of the chute crank through the hole in the shroud. Turn the chute crank rod **lightly** until the flattened end drops into the slot in the gear. Firmly push the chute crank into the gear until it snaps into place (Figs. 3 and 4).

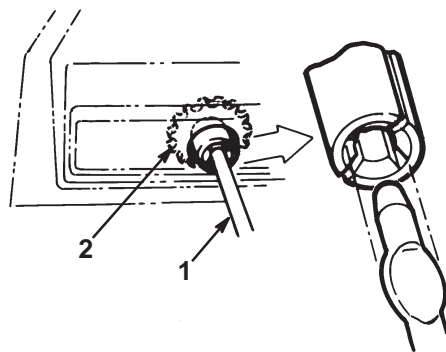

1533

Figure 4

- Chute crank
- Chute crank gear

- Secure the upper and lower tubing and the mounting plate together with two #10–24 machine screws and locknuts.

Note: Position the screw heads on the outside of the mounting plate. **Be careful not to damage the internal electrical wiring when inserting the screws.** If the wiring blocks the hole, use a blunt 1/8-in. punch to carefully route the electrical wiring away from the aligned holes.

Installing the Discharge Chute

- Position the deflector onto the discharge chute and align the mounting holes (Fig. 5).

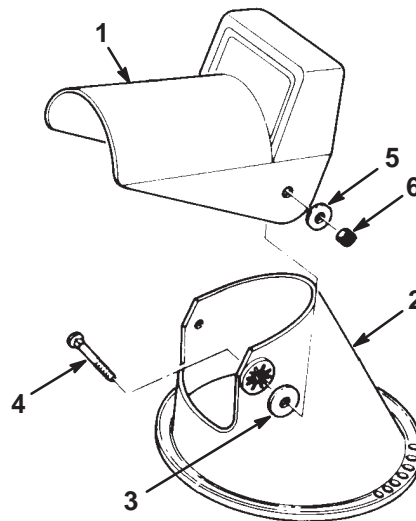

1534

Figure 5

- Chute deflector
- Chute
- Rubber washer
- Carriage bolt
- Metal washer
- Locknut

2. Insert a rubber washer between the deflector and the discharge chute while maintaining the hole alignment (Fig. 5).
3. Secure the deflector to the discharge chute with two 5/16–18 carriage bolts, metal washers, and locknuts.

Note: Make sure the square shoulders on the carriage bolts align with the inside square on the discharge chute. Position the metal washers to the outside of the deflector as shown in Figure 4. **Do not overtighten the bolts.**

Before Starting

Unlocking the Snowthrower

1. To unlock the snowthrower, push the key into the hole (Fig. 6). While holding the key down, turn the key counterclockwise. The interlock tab rotates away from the prongs, allowing the extension cord to be plugged in (Fig. 6). Do not attempt to remove the key when it is in the unlocked position.

Note: The interlock tab is a safety device that prevents an unauthorized person from using the snowthrower.

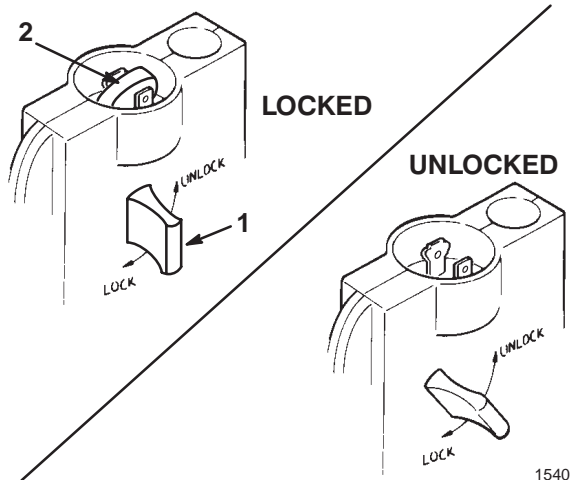

Figure 6

1. Key
2. Interlock tab

Securing the Power Supply Cord

For safe and efficient use of your appliance, use only a UL-listed extension cord recommended for outdoor use. Refer to the *Extension Cord Chart* that follows.

Extension Cord Chart		
If length of extension cord is less than or equal to:	100 ft.	150 ft.
Assure wire size gauge (A.W.G.) in cord is:	16	14

Note: Do not use an extension cord longer than 150 feet.

WARNING

POTENTIAL HAZARD

- Contact with water while operating the snowthrower can cause electric shock.

WHAT CAN HAPPEN

- Electric shock can cause injury or death.

HOW TO AVOID THE HAZARD

- Don't handle the plug or the appliance with wet hands or while standing in water.
- Use only a UL-listed extension cord recommended for outdoor cold weather use. Refer to the *Extension Cord Chart* on page 7.

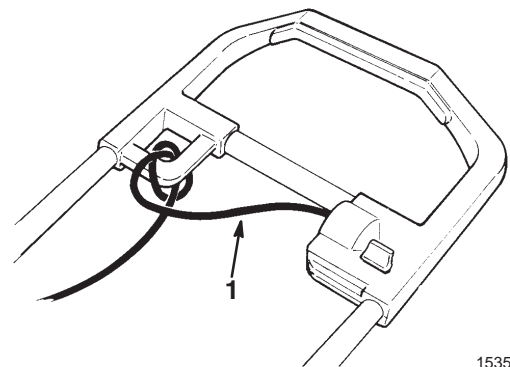

Figure 7

1. Extension cord

WARNING

POTENTIAL HAZARD

- The electrical cord can get damaged.

WHAT CAN HAPPEN

- A damaged electrical cord can cause a shock or fire.

HOW TO AVOID THE HAZARD

- Thoroughly inspect electrical cord before using the snowthrower. If the cord is damaged, do not operate the snowthrower. Replace or repair the damaged cord immediately. Contact your Authorized Service Dealer for assistance.

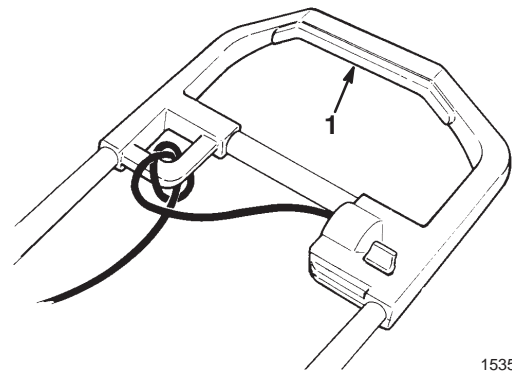

Figure 9

1. Control bar

Your snowthrower has a polarized plug, with one prong in the handle socket being larger than the other (Fig. 8). When you insert the end of a suitable extension cord into the handle socket, insert the enlarged prong into the wide slot in the extension cord end. Refer to *Safety* on page 2 for additional information.

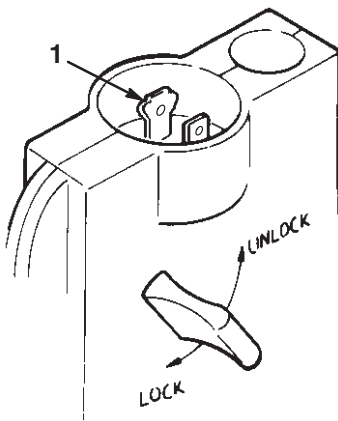

Figure 8

1. Enlarged prong

Operation

Before Operating

1. Check the condition of the snowthrower. Make sure the rotor turns freely.

Starting and Stopping

1. To start the rotor, squeeze the control bar (Fig. 9).

2. To stop the rotor, release the control bar.

Operating Tips

WARNING

POTENTIAL HAZARD

- If snowthrower hits a foreign object while in operation, the object could be thrown in operator's or bystander's direction.

WHAT CAN HAPPEN

- Thrown objects can cause serious personal injury.
- Snowthrower could be damaged.

HOW TO AVOID THE HAZARD

- Keep the area to be cleared free of all foreign objects which may be picked up and thrown by the rotor blades.

- Always keep children and pets away from the area of operation.
- Keep the area to be cleared free of stones, toys, or other foreign objects which the rotor blades can throw. Such items could be covered by snowfall and go unnoticed. If the snowthrower strikes an obstruction or a foreign object during operation, stop the snowthrower, unplug the extension cord, remove the obstruction, and check the snowthrower for damage.
- To adjust the discharge chute, rotate the chute crank clockwise to move the discharge chute to the left; counterclockwise to move the chute to the right.

Note: The chute crank makes a noise as you turn the crank. This is normal.

The deflector handle on top of the discharge chute controls the height of the snow stream (Fig. 10). Adjust the height of the snow stream by raising or lowering the chute deflector.

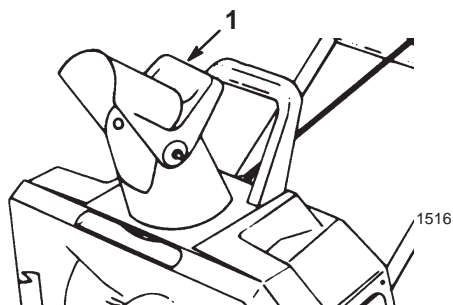

Figure 10

1. Chute deflector handle

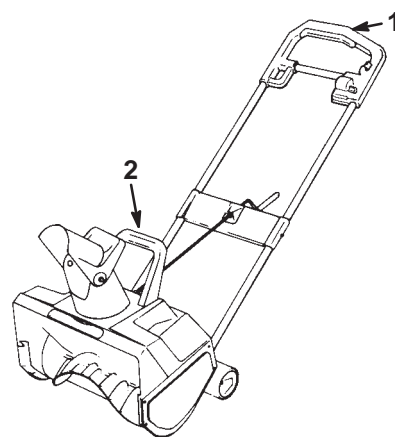

Figure 11

1. Primary handle 2. Secondary handle

! WARNING

POTENTIAL HAZARD

- A gap between the chute and the chute deflector will allow snow and anything that may be picked up by snowthrower to fly in the direction of the operator.

WHAT CAN HAPPEN

- Thrown objects could cause serious personal injury.

HOW TO AVOID THE HAZARD

- Do not force the chute deflector too far forward so that a gap appears between the chute and chute deflector.
- Do not overtighten the deflector mounting nuts so that you need to use excessive force to adjust the deflector.

- Begin removing snow near the electrical outlet and work outward. Blow back and forth, not away from and toward the outlet.
- When turning at the end of a swath, step over the cord and turn the snowthrower.
- Always overlap each swath and discharge the snow downwind when possible.
- Shave down large banks of snow by placing the snowthrower on the bank. Lift the snowthrower by the primary and secondary handles only (Fig. 11). Let the snowthrower's weight shave down the bank in a back-and-forth motion.

! WARNING

POTENTIAL HAZARD

- When using the secondary handle, never direct the snow discharge chute at the operator or at bystanders. Foreign objects could be thrown by snowthrower.

WHAT CAN HAPPEN

- Thrown objects could cause serious personal injury.

HOW TO AVOID THE HAZARD

- When using the secondary handle, always turn the discharge chute in the opposite direction from where you or bystanders are standing.

- Keep the extension cord clear of obstructions, sharp objects, and all moving parts. Do not pull sharply on cord or abuse it in any manner. Frequently inspect the extension cord for damage which can result in an electric shock. If the extension cord becomes damaged in any way, replace it.
- In some cold and snowy weather conditions, some controls and moving parts may freeze. Therefore, when any control becomes hard to operate, stop the motor, disconnect the extension cord and check for frozen parts. **Do not use excessive force when trying to operate frozen controls.** Free all the controls and moving parts before operating.
- When operating the snowthrower, keep the wheels one inch off the pavement by tipping the snowthrower forward. This helps prevent the snow from building up on the wheels.

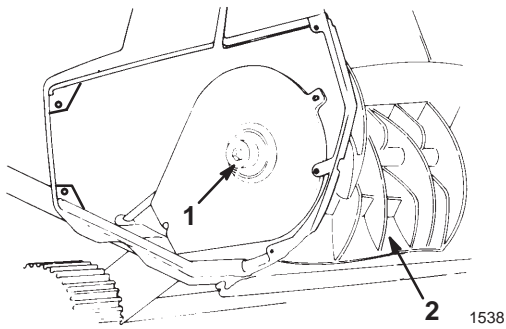

Figure 14

1. Rotor shaft 2. Rotor

Note: If you cannot remove the rotor shaft by holding the rotor, remove the left side cover and the skid (Fig. 15). Hold the hex nut with a 7/8-in. wrench while unscrewing the rotor shaft (Fig. 16).

3. Hold the rotor and pull out the rotor shaft.

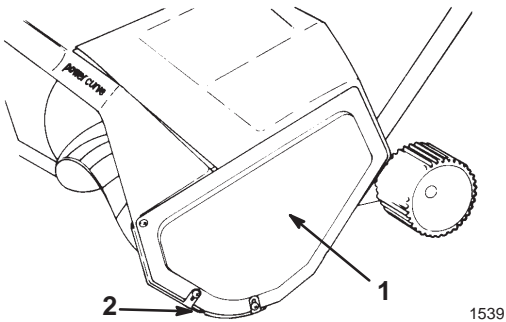

Figure 15

1. Left side cover 2. Skid

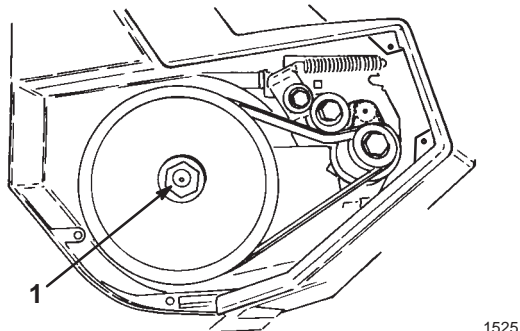

Figure 16

1. Hex nut

4. Remove the rotor. Keep the washer on the right side of the rotor for assembly. Replace the washer if it is worn.

5. If necessary, insert a new washer into the right side of the new rotor.
6. Align the left side of the new rotor with the coupler. The three bosses on the rotor end must align with the slots on the coupler (Fig. 17).

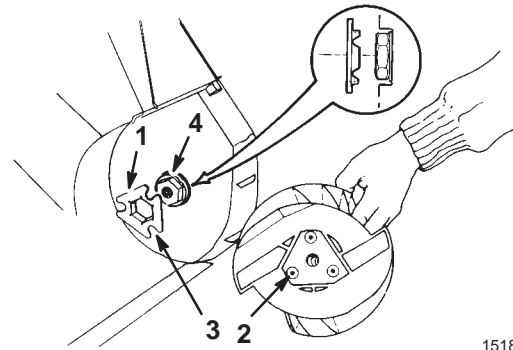

Figure 17

1. Coupler 3. Slot
2. Boss 4. Drive hex

Note: When mounting the coupler to the drive hex, align the coupler tabs to the inside.

7. Slide the right side of the rotor into the mounting position.
8. Insert the rotor shaft through the rotor. Make sure that the shaft fits into the bearing on the right side. Torque it to at least 10 ft-lb.
9. Install the cover and the skid.

Replacing the Large Belt

1. Remove the three screws that secure the left side plate to the snowthrower frame (Fig. 15). Remove the side plate and the skid.

CAUTION

POTENTIAL HAZARD

- The idler spring could fly in your face while you remove it.

WHAT CAN HAPPEN

- Contact with the flying spring can cause personal injury.

HOW TO AVOID THE HAZARD

- Wear safety goggles when working with the idler spring.

2. Remove the idler spring from the idler arm (Fig. 18).

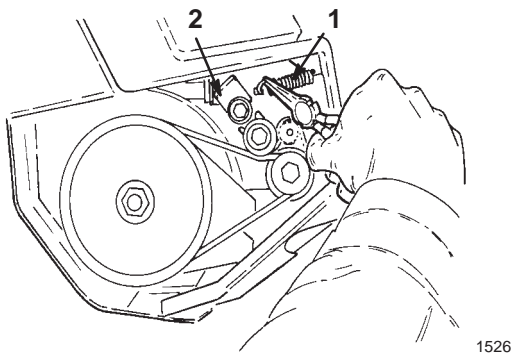

Figure 18

1. Idler spring
2. Idler arm

3. Rotate the rotor with your left hand while sliding the belt off the large pulley with your right hand (Fig. 19).

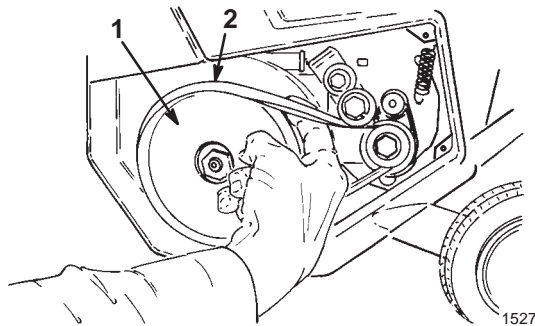

Figure 19

1. Large pulley
2. Belt

4. Slip the new belt over the small pulley. Lift up the idler arm and slip the belt under the idler pulley (Fig. 20). Rotate the rotor with your left hand while sliding the belt onto the large pulley with your right hand (Fig. 21).

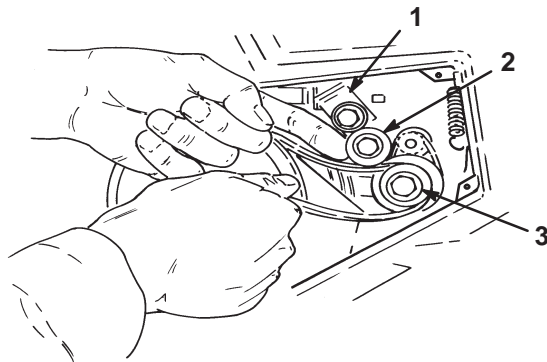

Figure 20

1. Idler arm
2. Idler pulley
3. Small pulley

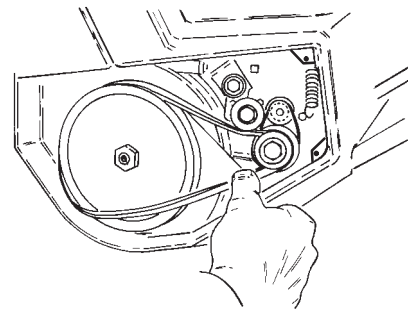

Figure 21

5. Assemble the idler spring, making sure the idler pulley rides on the belt.
6. Install the left side cover and the skid with the three screws.

Replacing the Small Belt

1. Remove the screws that secure the left side plate and the skid to the snowthrower frame (Fig. 15). Remove the side plate and the skid.
2. Remove the large belt by slowly sliding it off the small pulley (Fig. 19). Refer to steps 2 and 3 of *Replacing the Large Belt* on page 11.
3. Remove the small pulley bolt (left hand thread) by turning the bolt clockwise.
4. Remove the two washers and the small pulley (Fig. 22).

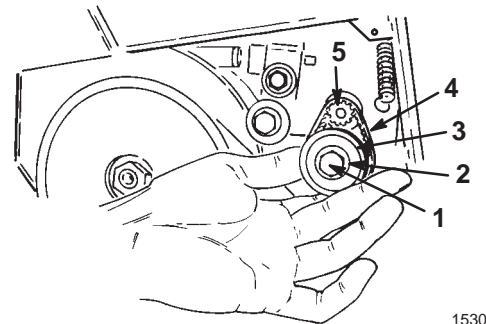

Figure 22

1. Bolt (left hand thread)
2. Washers
3. Small pulley
4. Small belt
5. Motor shaft pulley

5. Remove and discard the small belt (Fig. 22).
6. Slide two washers onto the bolt and insert the bolt through the small pulley.

Note: The bolt must ride on bearings in the small pulley.

7. Place the new belt on the small pulley.

8. Slide the belt over the motor shaft pulley (Fig. 22).
 9. When tightening the bolt, the bolt head and the washers must be flush against the small pulley. Torque the bolt to 25 to 30 in-lb. **Do not overtighten the bolt.**
 10. Slip the large belt over the small pulley (Fig. 21).
Refer to step 4 through 6 of *Replacing the Large Belt* on page 11.
2. Disconnect the extension cord from the snowthrower.
 3. Examine the extension cord thoroughly for signs of wear or damage. Replace it if it is worn or damaged.
 4. Examine the snowthrower thoroughly for worn, loose, or damaged parts. For repairing or replacing parts, contact your local Authorized Service Dealer for assistance.
 5. Store the extension cord with the snowthrower.
 6. Store the snowthrower in a clean, dry place. Cover it to provide protection.

Storage

1. Run the snowthrower for a few minutes to melt away any snow on the snowthrower.

Toro Service Support

If your snowthrower requires service or maintenance, your nearest Toro Master Service Dealer is the best dealer to assist you. Refer to the “Yellow Pages” of your local telephone directory in the section titled “Lawn Mowers.” Toro Master Service Dealers are listed under the Toro trademark. If you need help locating a Toro Master Service Dealer near you, call 1-800-421-9684 for assistance.

The Toro Promise

A Full Two Year Residential Use Warranty

The Toro Company warrants this TORO Product for two years against defects in material or workmanship. To receive a replacement or repair, at Toro's option, just return the complete unit, postage prepaid, to the seller or any TORO Electric Service Dealer or the TORO Service Center, 5300 Shoreline Blvd., Mound, MN 55364, along with proof of purchase. This warranty covers product defects only. It does not cover incidental or consequential damages. Some states do not allow the exclusion or limitation of incidental or consequential damages, so the above limitation may not apply to you. This warranty gives you specific rights, and you may have other rights which vary from state to state. If all other remedies fail, you may contact us at The Toro Company, Customer Service Department, 8111 Lyndale Ave S, Bloomington, MN, 55420-1196. (Do not return defective product to this address.)

COUNTRIES OTHER THAN THE UNITED STATES, CANADA OR MEXICO

Customers who have purchased TORO products exported from the United States or Canada should contact their TORO Distributor (Dealer) to obtain guarantee policies for your country, province, or state. If for any reason you are dissatisfied with your Distributor's service or have difficulty obtaining guarantee information, contact the TORO importer. If all other remedies fail, you may contact us at The Toro Company.