



Wheel Horse®

268H

Lawn and Garden Tractor

Model No. 72087 – 200000001 & Up

Operator's Manual

Introduction

Thank you for purchasing a Toro product.

All of us at Toro want you to be completely satisfied with your new product, so feel free to contact your local Authorized Service Dealer for help with service, genuine replacement parts, or other information you may require.

Whenever you contact your Authorized Service Dealer or the factory, always know the model and serial numbers of your product. These numbers will help the Service Dealer or Service Representative provide exact information about your specific product. You will find the model and serial number plate located in a unique place on the product as shown below.

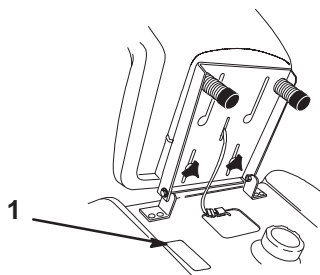

1202

1. Model and Serial Number Plate (under the seat)

For your convenience, write the product model and serial numbers in the space below.

Model No: _____
Serial No. _____

Read this manual carefully to learn how to operate and maintain your product correctly. Reading this manual will help you and others avoid personal injury and damage to the product. Although we design, produce and market safe, state-of-the-art products, you are responsible for using the product properly and safely. You are also responsible for training persons, who you allow to use the product, about safe operation.

The warning system in this manual identifies potential hazards and has special safety messages that help you and others avoid personal injury, even death. DANGER, WARNING and CAUTION are signal words used to identify the level of hazard. However, regardless of the hazard, be extremely careful.



DANGER signals an extreme hazard that will cause serious injury or death if the recommended precautions are not followed.

WARNING signals a hazard that may cause serious injury or death if the recommended precautions are not followed.

CAUTION signals a hazard that may cause minor or moderate injury if the recommended precautions are not followed.

Two other words are also used to highlight information. “Important” calls attention to special mechanical information and “Note” emphasizes general information worthy of special attention.

The left and right side of the machine is determined by sitting on the seat in the normal operator’s position.

	WARNING:	
The engine exhaust from this product contains chemicals known to the State of California to cause cancer, birth defects, or other reproductive harm.		

IMPORTANT: The engine in this product is not equipped with a spark arrester muffler. It is a violation of California Public Resource Code Section 4442 to use or operate this engine on any forest-covered, brush-covered or grass-covered land as defined in CPRC 4126. Other states or federal areas may have similar laws.

Contents

	Page		Page
Safety	2	Positioning the Seat	18
Safe Operating Practices	2	Headlights	18
Slope Chart	5	Positioning the Tilt Steering Wheel	18
Safety and Instruction Decals	7	Using the Cruise Control	19
Gasoline and Oil	8	Pushing the Machine by Hand	19
Recommended Gasoline	8	Maintenance	20
Stabilizer/Conditioner	9	Service Interval Chart	20
Filling the Fuel Tank	9	Air Cleaner	21
Check Engine Oil Level	9	Engine Oil	23
Operation	10	Spark Plug	25
Think Safety First	10	Greasing and Lubrication	26
Controls	10	Tire Pressure	26
Key Choice Switch	10	Brake	27
Parking Brake	10	Fuel Tank	28
Starting and Stopping		Fuel Filter	29
the Engine	11	Front Wheel Toe-In	30
Operating the Power Take Off (PTO)	12	Transaxle Fluid	31
The Safety Interlock System	13	Fuse	31
Operating–in–Reverse	13	Headlights	31
Indicator Control Module	15	Battery	33
Driving Forward or Backward	16	Wiring Diagram	36
Stopping the Machine	16	Cleaning and Storage	38
Attachment Lift Lever	17	Troubleshooting	39
Adjusting Dial-A-Height	17	Warranty	Back Cover

The enclosed Engine Owner’s Manual is supplied for information regarding The U.S. Environmental Protection Agency (EPA) and the California Emission Control Regulation of emission systems, maintenance and warranty.

Keep this engine Owner’s Manual with your unit. Should this engine Owner’s Manual become damaged or illegible, replace immediately. Replacements may be ordered through the engine manufacturer.

Safety

This machine meets or exceeds the B71.1–1996 specifications of the American National Standards Institute, in effect at the time of production. However, improper use or maintenance by the operator or owner can result in injury. To reduce the potential for injury, comply with these safety instructions and always pay attention to the safety alert  symbol, which means CAUTION, WARNING, or DANGER—“personal safety instruction.” Failure to comply with the instruction may result in personal injury or death.

Safe Operating Practices

This product is capable of amputating hands and feet and throwing objects. Always follow all safety instructions to avoid serious injury or death.

 WARNING
POTENTIAL HAZARD <ul style="list-style-type: none">• Engine exhaust contains carbon monoxide, which is an odorless, deadly poison.
WHAT CAN HAPPEN <ul style="list-style-type: none">• Carbon monoxide can kill you and is also known to the State of California to cause birth defects.
HOW TO AVOID THE HAZARD <ul style="list-style-type: none">• Do not run engine indoors or in an enclosed area.

General Operation

1. Read, understand, and follow all instructions in the operator’s manual and on the machine before starting.
2. Allow only responsible adults who are familiar with the instructions to operate the machine.
3. Clear the area of objects such as rocks, toys, wire, etc., which could be picked up and thrown by the blade.
4. Be sure the area is clear of other people before mowing. Stop the machine if anyone enters the area.
5. Never carry passengers.
6. Do not mow in reverse unless absolutely necessary. Always look down and behind before and while backing.
7. Be aware of the mower discharge direction and do not point it at anyone. Do not operate the mower without either the entire grass catcher or the guard in place.
8. Slow down before turning. Sharp turns on any terrain may cause loss of control.
9. Never leave a running machine unattended. Always turn off blades, set parking brake, stop engine, and remove the ignition and “Key Choice” keys before dismounting.
10. Turn off blades when not mowing.
11. Keep hands, feet, hair and loose clothing away from attachment discharge area, underside of mower and any moving parts while engine is running.
12. Stop the engine before removing the grass catcher or unclogging the chute.
13. Mow only in daylight or good artificial light.
14. Do not operate the machine while under the influence of alcohol or drugs.
15. Watch for traffic when operating near or crossing roadways.

16. Use extra care when loading or unloading the machine onto a trailer or truck.
17. Do not touch equipment or attachment parts which may be hot from operation. Allow to cool before attempting to maintain, adjust or service.

Slope Operation

Slopes are a major factor related to loss-of-control and tip-over accidents, which can result in severe injury or death. All slopes require extra caution. If you cannot back up the slope or if you feel uneasy on it, do not mow it.

DO

- Mow up and down slopes greater than 5°, not across.
- Mow downhill only on slopes above 10°, never mow uphill. If a steep slope must be ascended, back up the hill, and drive forward down the hill, keeping the machine in gear.
- Remove obstacles such as rocks, tree limbs, etc. from the mowing area. Watch for holes, ruts or bumps, as uneven terrain could overturn the machine. Tall grass can hide obstacles.
- Use slow speed. Choose a low gear so that you will not have to stop or shift while on the slope.
- Follow the manufacturer's recommendations for wheel weight or counterweights to improve stability.
- Use extra care with grass catchers or other attachments. These can change the stability of the machine.
- Keep all movement on slopes slow and gradual. Do not make sudden changes in speed or direction.
- Avoid starting or stopping on a slope. If tires lose traction, disengage the blades and proceed slowly straight down the slope.

DO NOT

- Do not operate machine on hillsides or slopes exceeding 15°.
- Avoid turning on slopes. If you must turn, turn slowly and gradually downhill, if possible.
- Do not mow near drop-offs, ditches, or embankments. The machine could suddenly turn over if a wheel goes over the edge of a cliff or ditch, or if an edge caves in.
- Do not mow on wet grass. Reduced traction could cause sliding.
- Do not try to stabilize the machine by putting your foot on the ground.
- Do not use a grass catcher on steep slopes. Heavy grass bags could cause loss of control or overturn the machine.

Children

Tragic accidents can occur if the operator is not alert to the presence of children. Children are often attracted to the machine and the mowing activity. Never assume that children will remain where you last saw them. The following requirements must be followed to prevent injury to children.

1. Keep children out of the mowing area and under the watchful care of another responsible adult.
2. Be alert and turn the machine off if children enter the area.
3. Before and while backing, look behind and down for small children.
4. Never carry children. They may fall off and be seriously injured or interfere with safe machine operation.
5. Never allow children to operate the machine.
6. Use extra care when approaching blind corners, shrubs, trees, the end of a fence or other objects that may obscure vision.

Service

1. Stop the engine, disconnect spark plug wire(s) and remove key before performing any service, repairs, maintenance or adjustments.
2. Use extra care when handling gasoline and other fuels. They are flammable and vapors are explosive.
 - A. Use only an approved container.
 - B. Never remove the gas cap or add fuel when the engine is running. Allow the engine to cool before refueling. Do not smoke.
 - C. Never refuel the machine indoors.
 - D. Never store the machine or fuel container inside where there is an open flame, such as near a water heater or furnace.
3. Never run a machine inside a closed area.

4. Keep nuts and bolts tight, especially the blade attachment bolts. Keep equipment in good condition.
5. Never tamper with safety devices. Check safety systems for proper operation before each use.
6. Keep the machine free of grass, leaves, or other debris build-up. Clean up oil or fuel spillage. Allow the machine to cool before storing.
7. Stop and inspect the equipment if you strike an object. Repair, if necessary, before restarting.
8. Grass catcher components are subject to wear, damage and deterioration, which could expose moving parts or allow objects to be thrown. Frequently check components and replace with manufacturer's recommended parts, when necessary.
9. Mower blades are sharp and can cut. Wrap the blade(s) or wear gloves, and use extra caution when servicing them.
10. Use only genuine replacement parts to ensure that original standards are maintained.
11. Check brake operation frequently. Adjust and service as required.
12. Battery acid is poisonous and can cause burns. Avoid contact with skin, eyes and clothing. Protect your face, eyes and clothing when working with a battery.
13. Battery gases can explode. Keep cigarettes, sparks and flames away from battery.

Slope Chart

Read all safety instructions on pages 2-4.

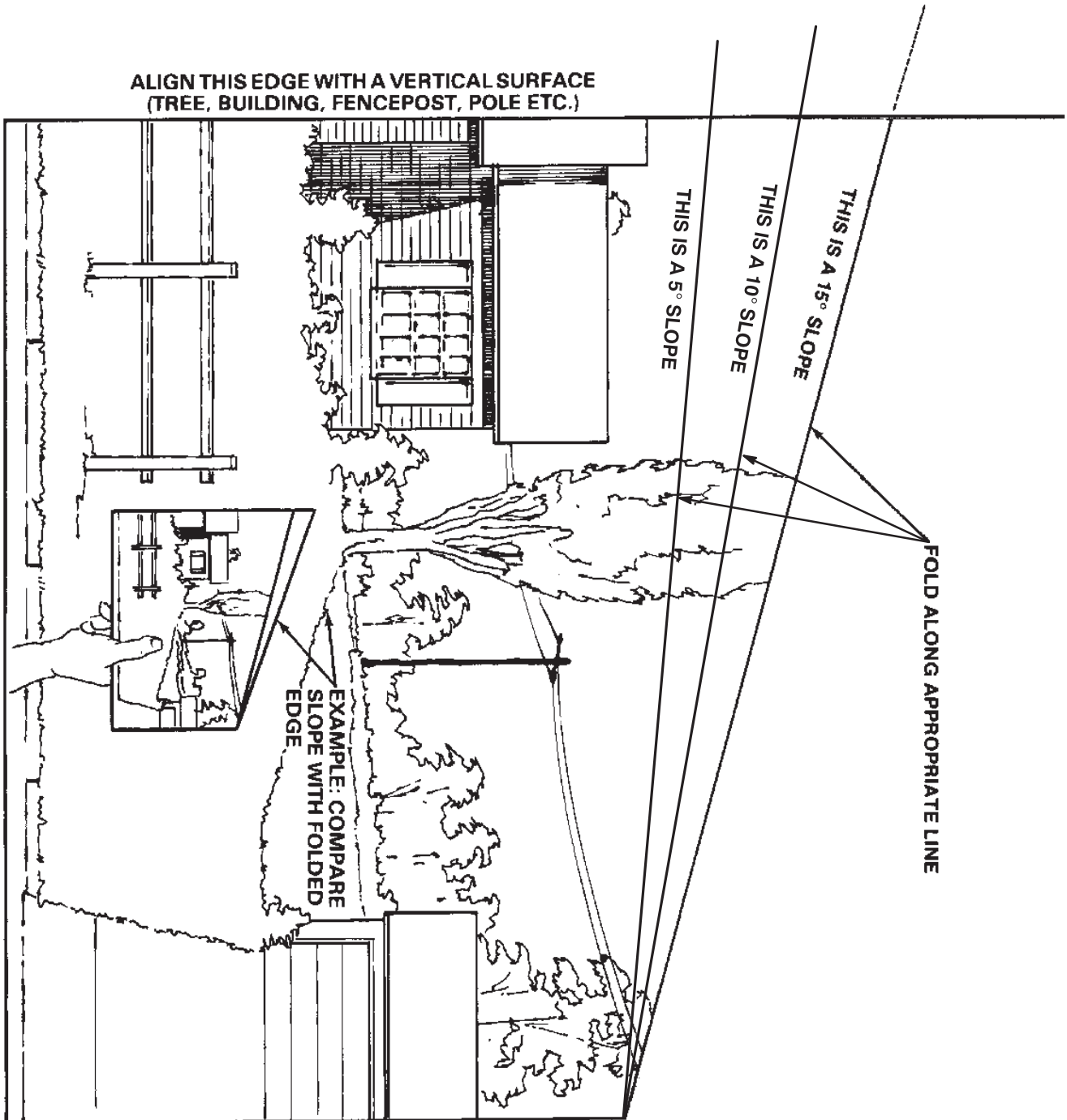

Safety and Instruction Decals



Safety decals and instructions are easily visible to the operator and are located near any area of potential danger. Replace any decal that is damaged or lost.

**ON STEERING TOWER
(Part No. 93-0302)**

⚠ DANGER

TO AVOID SERIOUS INJURY OR DEATH,

- READ AND UNDERSTAND THE OPERATOR'S MANUAL.
- KNOW LOCATION AND FUNCTION OF CONTROLS.
- NEVER USE WHEN UNDER THE INFLUENCE OF ALCOHOL OR DRUGS.
- USE SAFELY: MACHINE IS NOT A TOY; NEVER LET CHILDREN OPERATE.
- GO UP AND DOWN SLOPES, NOT ACROSS.
- AVOID SHARP OR SUDDEN TURNS AND SLIPPERY OR STEEP AREAS.
- IF MACHINE STOPS GOING UPHILL, STOP BLADE AND BACK SLOWLY DOWN.
- NEVER MOW WHEN CHILDREN OR OTHERS ARE IN THE MOWING AREA.
- NEVER CARRY CHILDREN OR OTHER PASSENGERS.
- LOOK DOWN AND BEHIND BEFORE AND WHILE BACKING UP.
- KEEP SAFETY DEVICES IN PLACE AND WORKING; CHECK BEFORE EACH USE.
- SAFETY INTERLOCKS CAN FAIL; NEVER ASSUME BLADE IS STOPPED.
- STOP ENGINE, SET PARKING BRAKE AND REMOVE KEY BEFORE LEAVING MACHINE.
- REMOVE OBJECTS THAT COULD BE THROWN BY THE BLADE.

NEVER MOW UP HILL OVER 15°

NEVER MOW DOWN HILL OVER 15°

HYDRO DRIVE PEDAL

BRAKE PEDAL

PARKING BRAKE

TO SET: DEPRESS BRAKE PEDAL AND LIFT LEVER

TO RELEASE: DEPRESS BRAKE PEDAL

**ON FRAME STEP
(Part No. 92-8946)**

⚠ DANGER

**DASH INDICATOR PANEL
(Part No. 99-8036)**

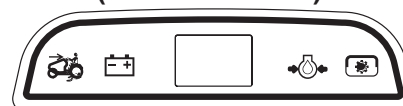

**ON FRAME CENTER REAR
(Part No. 92-6727)**

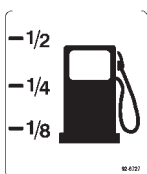

**ON FRAME RIGHT REAR
(Part No. 92-6726)**

TO OPERATE TRACTOR
MOVE LEVER FORWARD

↑

TO PUSH TRACTOR
LEVER MUST BE IN REARWARD POSITION

↓

DO NOT TOW

**ON DASH LEFT SIDE
(Part No. 92-6720)**

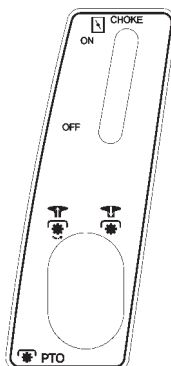

**ON DASH RIGHT SIDE
(Part No. 92-6721)**

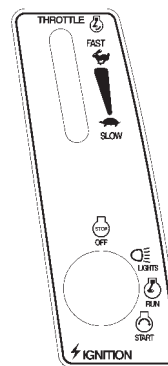

**ON LIFT LEVER
(Part No. 112168)**

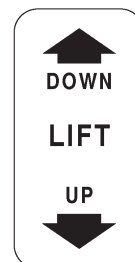

**ON STEERING TOWER
(Part No. 83-6620)**

READ YOUR OPERATOR'S MANUAL FOR OPERATING AND SAFETY INSTRUCTIONS. TO GET A REPLACEMENT MANUAL, SEND MODEL AND SERIAL NUMBERS TO: THE TORO CO., 8111 LYNDALE AVE. S., BLOOMINGTON, MN 55420-1196 83-6620

**ON FRAME STEP
(Part No. 92-6725)**

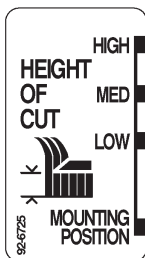

**ON DIAL-A-HEIGHT KNOB
(Part No. 78-9740)**

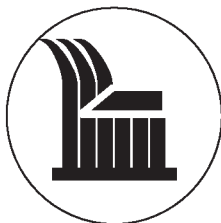

**ON SEAT BRACKET
(Part No. 99-2985)**

⚠ DANGER

NEVER MOW IN REVERSE IF THERE IS ANY POSSIBILITY OF CHILDREN APPEARING IN THE MOWING AREA. 99-2985

**ON SEAT BRACKET
(Part No. 99-5339A)**

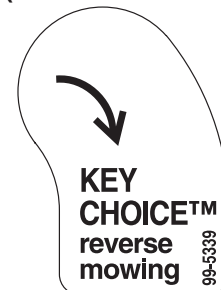

Gasoline and Oil

Recommended Gasoline

Use UNLEADED Regular Gasoline suitable for automotive use (85 pump octane minimum). Leaded regular gasoline may be used if unleaded regular is not available.

IMPORTANT: Never use methanol, gasoline containing methanol, or gasohol containing more than 10% ethanol because the fuel system could be damaged. Do not mix oil with gasoline.

DANGER

POTENTIAL HAZARD

- In certain conditions gasoline is extremely flammable and highly explosive.

WHAT CAN HAPPEN

- A fire or explosion from gasoline can burn you, others, and cause property damage.

HOW TO AVOID THE HAZARD

- Fill the fuel tank outdoors, in an open area, when the engine is cold. Wipe up any gasoline that spills.
- Do not fill the fuel tank completely full. Add gasoline to the fuel tank until the level is 1/4" to 1/2" (6 mm to 13 mm) below the bottom of the filler neck. This empty space in the tank allows gasoline to expand.
- Never smoke when handling gasoline, and stay away from an open flame or where gasoline fumes may be ignited by a spark.
- Store gasoline in an approved container and keep it out of the reach of children. Never buy more than a 30-day supply of gasoline.

DANGER

POTENTIAL HAZARD

- In certain conditions gasoline is extremely flammable and highly explosive.

WHAT CAN HAPPEN

- A fire or explosion from gasoline can burn you, others, and cause property damage.

HOW TO AVOID THE HAZARD

- Always place gasoline containers on the ground away from your vehicle before filling.
- Do not fill gasoline containers inside a vehicle or on a truck or trailer bed because interior carpets or plastic truck bed liners may insulate the container and slow the loss of any static charge.
- When practical, remove gas-powered equipment from the truck or trailer and refuel the equipment with its wheels on the ground.
- If this is not possible, then refuel such equipment on a truck or trailer from a portable container, rather than from a gasoline dispenser nozzle.
- If a gasoline dispenser nozzle must be used, keep the nozzle in contact with the rim of the fuel tank or container opening at all times until fueling is complete.

Using Stabilizer/Conditioner

Use a fuel stabilizer/conditioner in the machine to provide the following benefits:

- Keeps gasoline fresh during storage of 90 days or less. For longer storage it is recommended that the fuel tank be drained.
- Cleans the engine while it runs
- Eliminates gum-like varnish buildup in the fuel system, which causes hard starting

IMPORTANT: Do not use fuel additives containing methanol or ethanol.

Add the correct amount of gas stabilizer/conditioner to the gas.

Note: A fuel stabilizer/conditioner is most effective when mixed with fresh gasoline. To minimize the chance of varnish deposits in the fuel system, use fuel stabilizer at all times.

Filling the Fuel Tank

1. Shut the engine off and set the parking brake.
2. Clean around each fuel tank cap and remove the cap. Add unleaded regular gasoline to both fuel tanks, until the level is 1/4 to 1/2 inch (6 mm to 13 mm) below the bottom of the filler neck. This space in the tank allows gasoline to expand. Do not fill the fuel tanks completely full.
3. Install fuel tank caps securely. Wipe up any gasoline that may have spilled.
4. Fuel gauge is located in right side tank.

Check Engine Oil Level

Before you start the engine and use the machine, check the oil level in the engine crankcase; refer to Checking Oil Level, page 24.

Operation

Think Safety First

Please carefully read all the safety instructions on pages 2–7. Knowing this information could help you, your family, pets or bystanders avoid injury.

Controls

Become familiar with all the controls (Fig. 1) before you start the engine and operate the machine.

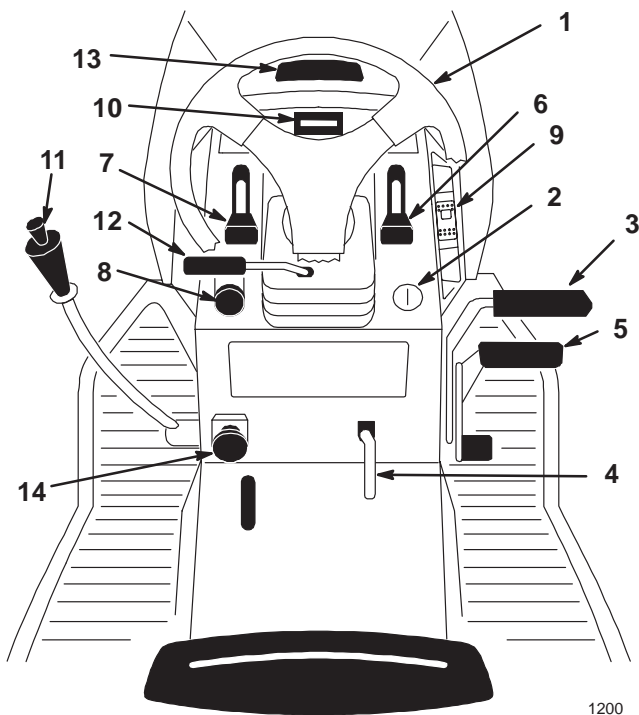

Figure 1

- | | |
|---------------------------|--|
| 1. Steering wheel | 9. Cruise control switch |
| 2. Ignition switch | 10. Indicator control module/Hourmeter |
| 3. Brake pedal | 11. Attachment lift lever |
| 4. Parking brake lever | 12. Tilt wheel lever |
| 5. Traction control pedal | 13. Hood opening |
| 6. Throttle lever | 14. Dial-a-height knob |
| 7. Choke lever | |
| 8. Power take off (PTO) | |

Key Choice Switch

A turn and release switch used for deactivating the “Operating–In–Reverse” interlock feature. Located on the seat bracket on the right hand just below the seat (Fig. 2).

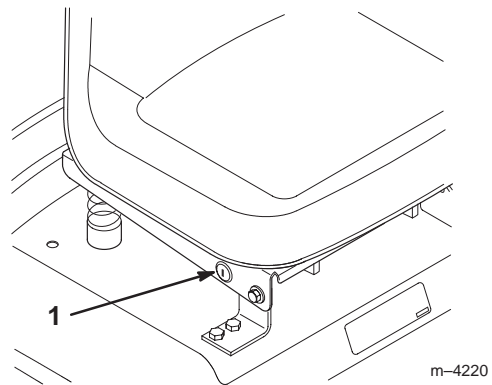

Figure 2

1. “Key Choice” switch

Parking Brake

Always set the parking brake when you stop the machine or leave it unattended.

Setting the Parking Brake

1. Push the brake pedal (Fig. 3) down and hold it in the depressed position.
2. Lift the parking brake lever (Fig. 3) up and gradually take your foot off the brake pedal. The brake pedal should stay in the depressed (locked) position.

Releasing the Parking Brake

1. Push down on the brake pedal (Fig. 3). The parking brake lever should release.
2. Gradually release the brake pedal.

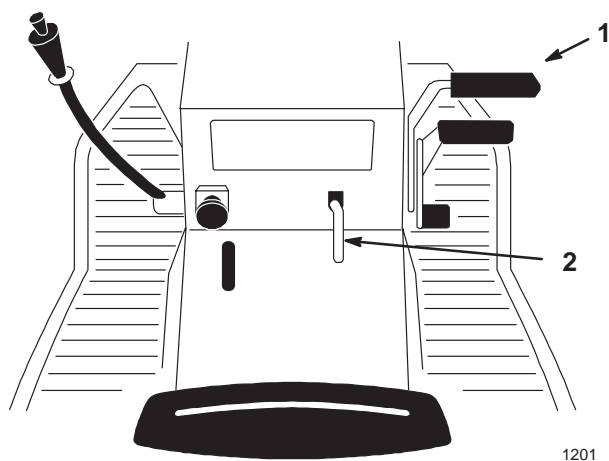

Figure 3

1. Brake pedal 2. Parking brake lever

Starting and Stopping the Engine

Starting

1. Sit down on the seat.
2. Set the parking brake; refer to Setting the Parking Brake, page 10.

Note: The engine will not start unless you set the parking brake or fully depress the brake pedal and are seated.

3. Push the PTO (power take off) to “OFF” (Fig. 4).
4. Move the choke lever to “ON” (Fig. 4).

Note: An engine that has been running and is warm may not require step 4.

5. Move throttle lever to “FAST” (Fig. 5).
6. Turn the ignition key clockwise and hold it in the “START” position (Fig. 6). When the engine starts, release the key.

IMPORTANT: If the engine does not start after 30 seconds of continuous cranking, turn the ignition key to “OFF” and let the starter motor cool; refer to Troubleshooting, page 40.

7. After the engine starts, move the choke lever to “OFF” and slowly move the throttle to the desired setting (Fig. 5). If the engine stalls or hesitates, move the choke lever back to “ON” for a few seconds. Then move the throttle lever to desired setting. Repeat this as required.

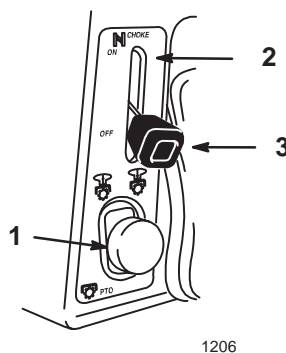

Figure 4

1. PTO—Off
2. Choke—On
3. Choke—Off

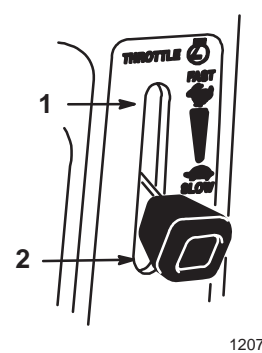

Figure 5

1. Fast
2. Slow

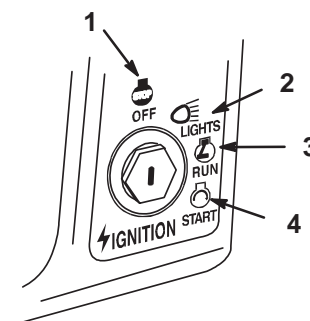

Figure 6

1. Off
2. Lights
3. Run
4. Start

Stopping

1. Move the throttle lever to “SLOW” (Fig. 5).
2. Turn the ignition key to “OFF” (Fig. 6).

Note: If the engine has been working hard or is hot, let it idle for a minute before turning the ignition key “OFF.” This helps cool the engine before it is stopped. In an emergency, the engine may be stopped by turning the ignition key to “OFF.”

Operating the Power Take Off (PTO)

The power take off (PTO) engages and disengages power to the electric clutch.

While the ignition key is in “RUN” or “LIGHTS” position and the power take off (PTO) is engaged “ON”, the PTO light, in the Indicator Module, will be “ON”. When this light is “ON” it is a reminder the starter will not crank and to turn the off PTO before getting off the tractor.

Engaging the Power Take Off (PTO)

1. Depress the brake pedal to stop the machine.
2. Pull the power take off (PTO) to “ON” (Fig. 7).

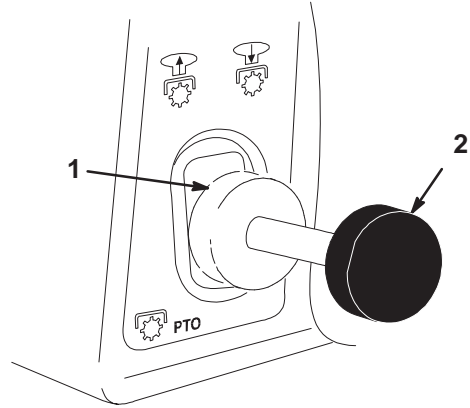

1206

Figure 7

1. Off-Disengaged
2. On-Engaged

Disengaging the Power Take Off (PTO)

1. Depress the brake pedal to stop the machine.
2. Push the power take off (PTO) to “OFF” (Fig. 7).

The Safety Interlock System

Understanding the Safety Interlock System

The safety interlock system is designed to prevent the engine from starting unless:

- You are sitting on the seat
- The brake pedal is depressed
- The power take off (PTO) is “OFF”
- The hydro control pedal is in the neutral position.

The safety interlock system is designed to stop the engine if:

- You rise from the seat when the brake pedal is released
- You rise from the seat when the power take off (PTO) is “ON” or gear selector is not in “N” neutral.
- You move the hydro control pedal out of the neutral position when the parking brake is engaged.

The safety interlock system is designed to stop the power take off (PTO) if:

- You shift into reverse with the power take off (PTO) engaged.

Operating–in–Reverse

An interlock feature is provided that prevents the Power Take Off (PTO) from operating while the tractor is traveling in reverse. If the unit is shifted into reverse while the mower blade or other PTO driven attachment is engaged, the PTO will stop.

Do not mow while backing up unless it is absolutely necessary. If you need to mow while in reverse gear or use other PTO driven attachments

(such as a snowthrower or tiller), this no operating–in–reverse interlock may be temporarily deactivated.

Before deactivating this interlock, be sure there are no children present on or near the property where you are using the tractor, and that none are likely to appear while you are mowing or operating an attachment. Be extra observant after you have chosen to deactivate the interlock because the sound of the tractor’s engine might prevent you from being aware that a child or a bystander has entered the area where you are operating the tractor.

If you are certain that you can safely mow in reverse or operate an attachment, deactivate the no operating–in–reverse interlock by turning the “Key Choice” switch (Fig. 8), located on the seat bracket on the right hand side just below the seat, after engaging the blade (PTO). A red light on the front console (Fig. 9) will turn on as a reminder that the no operating–in–reverse interlock has been deactivated. Once the interlock is deactivated it stays in this mode—with your mower blade or PTO–driven attachment operating whenever you back up— and the console light stays on until either the blade (PTO) is disengaged, or the engine is turned off.

Note: Do not insert the “Key Choice” key unless it is absolutely necessary to mow in reverse or operate an attachment. The “Key Choice” key should also be removed from the unit if it will be operated by someone other than a responsible, experienced operator. This will prevent the unit from operating in reverse with the mower blade or other PTO attachment engaged. Always remove both the ignition and the “Key Choice” keys and put them in a safe place out of the reach of children when leaving the unit unattended.

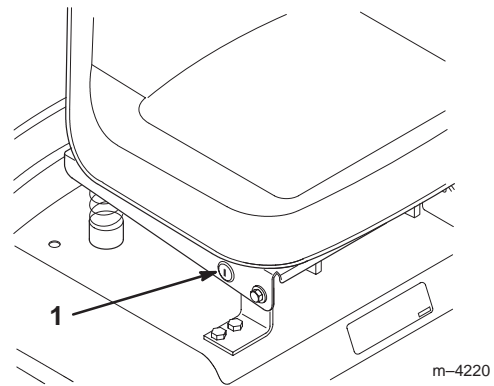

Figure 8

1. “Key Choice” switch

⚠ DANGER

POTENTIAL HAZARD

- A child or bystander could be backed over by a riding mower with its blade(s) engaged.

WHAT CAN HAPPEN

- Blade contact will cause serious personal injury or death.

HOW TO AVOID THE HAZARD

- Do not mow in reverse unless absolutely necessary.
- Always look backward and down before backing up.
- Use “Key Choice” switch only if you are certain no children or other bystanders will appear in the mowing area.
- Always remove both the ignition and “Key Choice” keys and put them in a safe place out of the reach of children or unauthorized users when leaving the unit unattended.

Testing the Safety Interlock System

Test the safety interlock system before you use the machine each time. If the safety system does not operate as described below, have an Authorized Service Dealer repair the safety system immediately.

1. Set the parking brake. Move the power take off (PTO) to “ON”. Now turn the ignition key to “START”; the engine should not crank.
2. Push the power take off (PTO) to “OFF” and release the parking brake. Now turn the ignition key to “START”; the engine should not crank.
3. Set the parking brake, move the power take off (PTO) to “OFF” and move the hydro control pedal forward from the neutral; the engine should not crank.
4. Set the parking brake and move the power take off (PTO) to “OFF”(On gear drive models the speed selector lever must be in “N” neutral). Now start the engine. While the engine is running, release the parking brake and rise slightly from the seat; the engine should stop.
5. Set the parking brake and restart the engine. While the engine is running, and the parking brake is engaged, move the hydro pedal forward; the engine should stop.

6. With the parking brake released, turn the ignition key to RUN without starting the engine. Pull the PTO switch to ON. You should hear an audible click indicating the PTO is activated and the PTO light will illuminate. Move the foot pedal to reverse. You should hear an audible click indicating the PTO is deactivated and the PTO light should turn off.
7. With the parking brake released, turn the ignition switch to RUN without starting the engine. Pull the PTO switch to ON. Turn the “Key Choice” key and release. The Operating-in-Reverse warning light should illuminate. Move the foot pedal to reverse. The PTO and PTO light on the dash should remain on. Push the PTO switch to OFF. The PTO light and the Operating-in-Reverse warning light should turn off.

Indicator Control Module

The indicator control module (optional on some models) (Fig. 9) lights when the parking brake or power take off (PTO), is actuated and when there is a problem of low oil pressure or alternator output, that needs immediate attention.

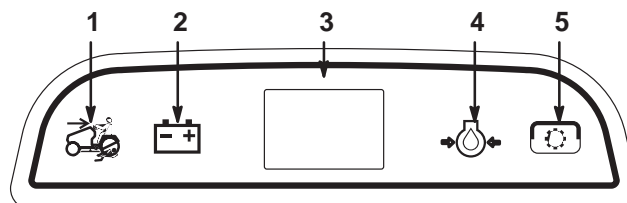

Figure 9

- | | |
|-------------------------|-------------------------|
| 1. Operating-in-Reverse | 4. Oil |
| 2. Battery | 5. PTO (power take off) |
| 3. Hourmeter | |

Following are the conditions when indicator lights will be “ON”. At other times the lights should be off.

Operating-in-Reverse

The Operating-in-Reverse light will illuminate whenever the “Key Choice” switch is used to deactivate the operating-in-reverse interlock. It is a reminder that the interlock system is deactivated. The light goes out whenever the power take off (PTO) is disengaged or the engine is shut off.

Battery

The battery light will be “ON” when the key is in the “RUN” or “LIGHTS” positions if the battery voltage is below 12.6 volts or when the engine is running and the alternator output is above 14.8 volts. When this light comes on it is important to have your battery and electrical system checked and the problem corrected.

Hourmeter

The hourmeter (optional on some models) records the number of hours the engine has operated (Fig. 9). It is turned on when the ignition switch is in the “RUN” or “LIGHTS” positions. Use the times for scheduling regular maintenance.

Oil

The oil light will be “ON” when the key is in the “RUN” or “LIGHTS” positions and the engine is not running, after the engine is started the light should go out. When the engine is running if the oil pressure drops below a safe operating level the light comes “ON”. When the light comes on while the engine is running, **Stop engine immediately and correct the cause of low oil pressure.**

PTO (Power Take Off)

The PTO (power take off) light will be “ON” when the key is in the “RUN” or “LIGHTS” positions and the PTO (power take off) is engaged “ON”. When this light is “ON” it is a reminder; the starter will not crank and turn off the PTO before getting off.

Driving Forward or Backward

The throttle control regulates the engine speed as measured in rpm (revolutions per minute). Place the throttle control in the “FAST” position for best performance.

To go forward or backward, release the parking brake: refer to Releasing the Parking Brake, page 10. Place your foot on the traction control pedal and slowly press on the top of the traction control pedal to move forward or on the bottom of the traction control pedal to move backward (Fig. 10). The farther you move the traction control pedal in either direction, the faster the machine will move in that direction.

Note: For reverse motion, with the PTO engaged, the operating-in-reverse interlock must be deactivated by the “Key Choice” switch located on the seat bracket on the right hand side just below the seat.

To slow down, release the pressure on the traction control pedal.

IMPORTANT: To avoid transmission damage, always release the parking brake before moving the traction control pedal.

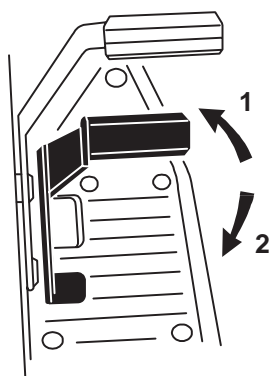

Figure 10

1. Forward

2. Backward

Stopping the Machine

To stop the machine, release the traction control pedal, disengage the power take off (PTO), and turn the ignition key to “OFF” to stop the engine. Also set the parking brake if you leave the machine unattended; refer to Setting the Parking Brake, page 10. Remember to remove the ignition and “Key Choice” keys from the switches.

CAUTION

POTENTIAL HAZARD

- Someone could move or attempt to operate the tractor while it is unattended.

WHAT CAN HAPPEN

- Children or bystanders may be injured if they use the tractor.

HOW TO AVOID THE HAZARD

- Always remove the ignition and “Key Choice” keys and set the parking brake when leaving the machine unattended, even if just for a few minutes.

1210

Attachment Lift Lever

The attachment lift lever (Fig. 11) is used to raise and lower various attachments.

Raising Attachments

1. Depress the brake pedal to stop the machine.
2. Pull attachment lift lever rearward until latch locks. In this position the lift will hold the attachment in the up, or raised position.

Lowering Attachments

1. Depress the brake pedal to stop the machine.
2. Pull attachment lift lever rearward, to release lift pressure, and push the button on top to release the latch. Move lift lever forward to lower attachment.

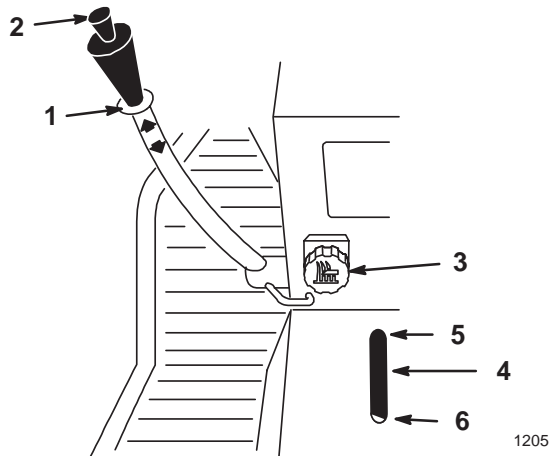

Figure 11

- | | |
|------------------|----------------------|
| 1. Lift lever | 4. Indicator |
| 2. Button | 5. High |
| 3. Dial-A-Height | 6. Mounting position |

Adjusting Dial-A-Height

The Dial-A-Height control (Fig. 11) is used to limit the downward travel of the attachment. The Dial-A-Height knob is rotated to change the location of this stop, up or down.

1. Raise the attachment lift lever: Refer to Raising Attachments. In the raised position the Dial-A-Height knob (Fig. 11) can be rotated to change the stop location. Turn clockwise to raise and counterclockwise to lower the height of the attachment.
2. The Dial-A-Height indicator (Fig. 11) will show the change, high to low, in attachment lift height as adjustment is made.

Positioning the Seat

The seat can move forward and backward. Position the seat where you have the best control of the machine and are most comfortable.

1. Raise the seat and loosen the adjustment knobs (Fig. 12).
2. Slide the seat to the desired position and tighten the knobs.

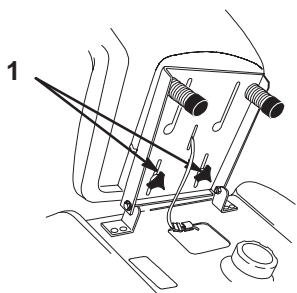

1202

Figure 12

1. Adjustment knob

Positioning the Tilt Steering Wheel

The steering wheel has four tilt locations. Position the steering wheel where you have the best control of the machine and are most comfortable.

1. Lift the tilt lever to release the lock (Fig. 14).
2. Move the steering wheel to a comfortable position; then release the lever to lock.

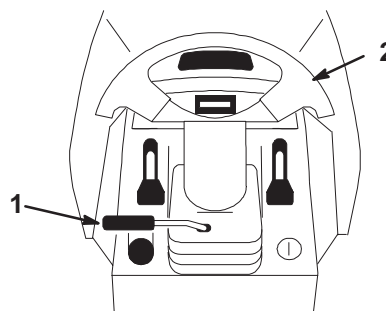

1203b

Figure 14

1. Tilt lever
2. Steering wheel

Headlights

The headlights are turned on with a separate position, “LIGHTS”, of the ignition switch (Fig. 13). The lights are on while the ignition switch is in the “LIGHTS” position even with the engine off. Remove the key when the machine is left unattended so lights can not be turned on discharging the battery.

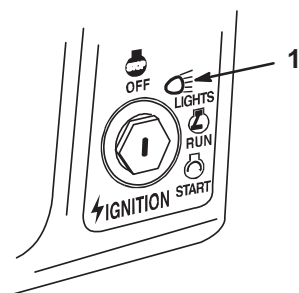

1208

Figure 13

1. Lights

Using the Cruise Control

The cruise control is optional on some models. A 3 position: Set-Lock (spring loaded), On and Off-Unlock dash switch (Fig. 15) controls the engagement. Cruise control maintains the traction control position without foot pressure. Cruise control is intended for operation in the forward direction only. Do not use cruise control in reverse.

Engaging the Cruise Control

1. Begin driving tractor: Refer to Driving Forward or Backward, Page 17. While holding your foot steady on the traction control, push the cruise control switch (Fig. 15) to the “SET”–“LOCK” position.

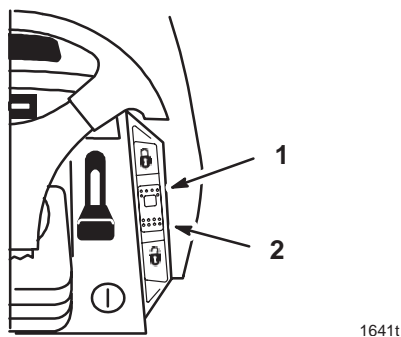

Figure 15

1. Lock-Set
2. Unlock-Off

2. This locks the traction control in position and your foot can then be removed from the traction control. A constant ground speed will be maintained.

Disengaging the Cruise Control

1. While holding your foot steady on the traction control, move the cruise control switch (Fig. 15) to the “UNLOCK”–“OFF” position.
2. This unlocks the traction control and your foot then operates the traction control.
3. For quick stops, just press on the brake pedal. This automatically disengages the cruise control and applies the brake at the same time.

Pushing the Machine by Hand

IMPORTANT: Always push the machine by hand. Never tow the machine because transaxle damage may occur.

To Push the Machine

1. Disengage the power take off (PTO) and turn the ignition key to “OFF” to stop the engine.
2. Move the drive control rod to the “PUSH” position. This disengages the drive system and allows the wheels to turn freely (Fig. 16).

To Operate the Machine

1. Move the drive control rod to the “OPERATE” position (Fig. 16).

Note: The machine will not drive unless the drive control rod is in the “OPERATE” position.

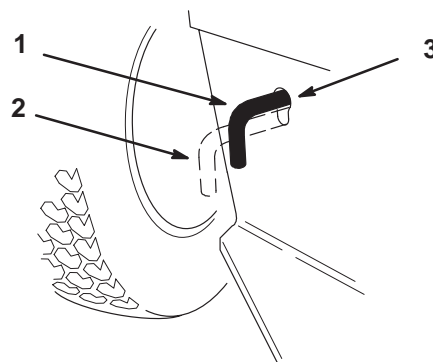

Figure 16

1. Operate position
2. Push position
3. Drive Control Rod

Maintenance

Service Interval Chart

Service Operation	Each Use	5 Hours	25 Hours	50 Hours	100 Hours	Storage Service	Spring Service
Oil—check level	X						
Oil—change*		Initial			X		
Oil Filter—change* (200 hours, every other oil change or yearly)					X	X	
Safety System—check	X						X
Brake—check	X	X				X	X
Chassis—grease*				X		X	
Foam Air Cleaner—service*			X			X	
Paper Air Cleaner—replace*					X	X	
Spark Plug(s)—check			X			X	X
Belts—check for wear/cracks				X		X	
Gasoline—drain						X	
Engine—clean outside	X		X			X	
Chipped Surfaces—paint						X	
Battery—check electrolyte		X				X	X
Battery—charge, disconnect cables						X	
Fuel Filter—replace					X	X	
Tires—check pressure			X			X	X
Front Wheels—check toe-in			X			X	
* More often in dusty, dirty conditions							

CAUTION

POTENTIAL HAZARD

- If you leave the key in the ignition switch, someone could start the engine.

WHAT CAN HAPPEN

- Accidental starting of the engine could seriously injure you or other bystanders.

HOW TO AVOID THE HAZARD

- Remove the key from the ignition switch and pull the wire(s) off the spark plug(s) before you do any maintenance. Also push the wire(s) aside so it does not accidentally contact the spark plug(s).

Air Cleaner

Service Interval/Specification

Foam Element: Clean and re-oil after every 25 operating hours, or yearly, whichever occurs first.

Paper Element: Replace after every 100 operating hours or yearly, whichever occurs first.

Note: Service the air cleaner more frequently (every few hours) if operating conditions are extremely dusty or sandy.

Removing the Foam and Paper Elements

1. Disengage the power take off (PTO), set the parking brake, and turn the ignition key to "OFF" to stop the engine. Remove the ignition key.
2. Open the hood.
3. Clean around the air cleaner to prevent dirt from getting into the engine and causing damage. Remove knob and the air cleaner cover (Fig. 17).

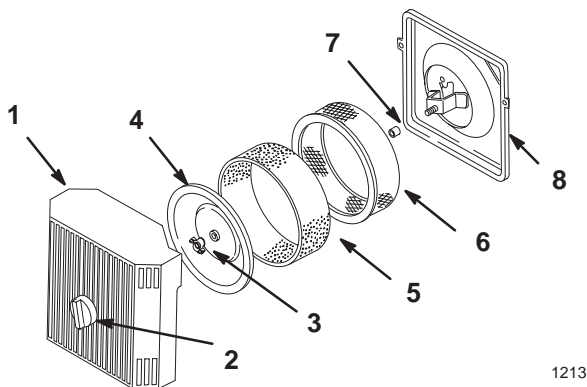

Figure 17

- | | |
|----------------------|---------------------|
| 1. Air cleaner cover | 5. Foam element |
| 2. Knob | 6. Paper element |
| 3. Cover nut | 7. Rubber seal |
| 4. Cover | 8. Air cleaner base |

4. Carefully slide the foam element off the paper element (Fig. 17).
5. Unscrew the cover nut and remove the cover and paper element (Fig. 17).

Cleaning the Foam and Paper Elements

1. Foam Element
 - A. Wash the foam element in liquid soap and warm water. When the element is clean, rinse it thoroughly.
 - B. Dry the element by squeezing it in a clean cloth.
 - C. Put one or two ounces of oil on the element (Fig. 18). Squeeze the element to distribute the oil.

IMPORTANT: Replace the foam element if it is torn or worn.

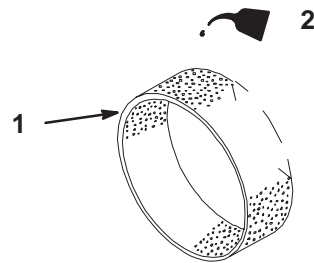

Figure 18

- | | |
|-----------------|--------|
| 1. Foam element | 2. Oil |
|-----------------|--------|

2. Paper Element

- A. Lightly tap the element on a flat surface to remove dust and dirt (Fig. 19).
- B. Inspect the element for tears, an oily film, and damage to the rubber seal.

IMPORTANT: Never clean the paper element with pressurized air or liquids, such as solvent, gas, or kerosene. Replace the paper element if it is damaged or cannot be cleaned thoroughly.

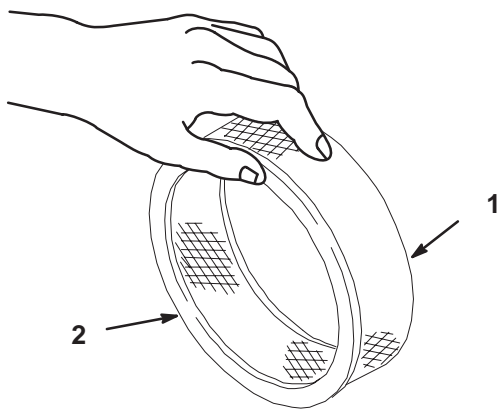

1213

Figure 19

1. Paper element
2. Rubber seal

Installing the Foam and Paper Elements

IMPORTANT: To prevent engine damage, always operate the engine with the complete foam and paper air cleaner assembly installed.

1. Carefully slide the foam element onto the paper air cleaner element (Fig. 17).
2. Slide the air cleaner assembly and cover onto the long rod. Now screw the cover nut finger-tight against the cover (Fig. 17).

Note: Make sure the rubber seal is flat against the air cleaner base and cover.

3. Install the air cleaner cover (Fig. 17).
4. Close the hood.

Engine Oil

Service Interval/Specification

Change oil:

- After the first 5 operating hours.
- After every 100 operating hours.

Note: Change oil more frequently when operating conditions are extremely dusty or sandy.

Oil Type: Detergent oil (API service SF or SG)

Crankcase Capacity: w/filter, 4 pints (1.9 l)

Viscosity: See table below

USE THESE SAE VISCOSITY OILS

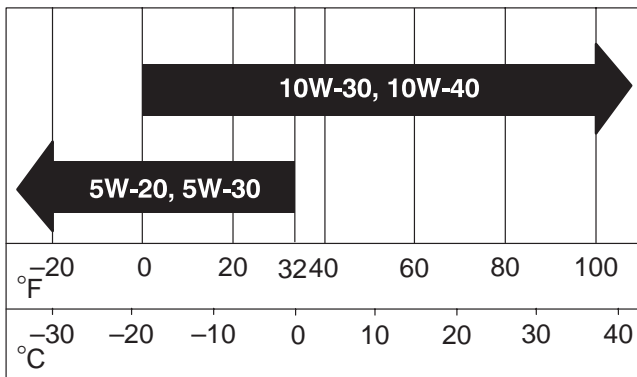

Checking Oil Level

1. Park the machine on a level surface, disengage the power take off (PTO), set the parking brake, and turn the ignition key to “OFF” to stop the engine. Remove the ignition key.
2. Open the hood.
3. Clean around the oil dipstick (Fig. 20) so dirt cannot fall into the filler hole and damage the engine.
4. Unscrew the oil dipstick and wipe the metal end clean (Fig. 20).
5. Slide the oil dipstick fully into the filler tube, do not thread onto tube (Fig. 20). Pull the dipstick out and look at the metal end. If oil level is low, slowly pour only enough oil into the filler tube to raise the level to the “FULL” mark.

IMPORTANT: Do not overfill the crankcase with oil because the engine may be damaged.

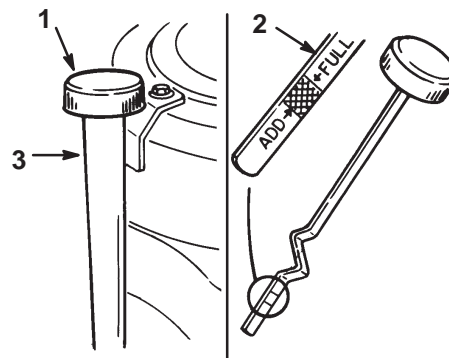

Figure 20

1. Oil dipstick
2. Metal end
3. Filler tube

Changing/Draining Oil

1. Start the engine and let it run five minutes. This warms the oil so it drains better.
2. Park the machine so that the drain side is slightly lower than the opposite side to assure the oil drains completely. Then disengage the power take off (PTO), set the parking brake, and turn the ignition key to "OFF" to stop the engine. Remove the ignition key.
3. Open the hood.
4. Slide a piece of hose over oil drain to direct oil.
5. Place a pan below the oil drain. Open the drain by turning counterclockwise, 1/8 turn and pull out (Fig. 21).
6. When oil has drained completely, close the drain by pushing in and turning clockwise, 1/8 turn.

Note: Dispose of the used oil at a certified recycling center.

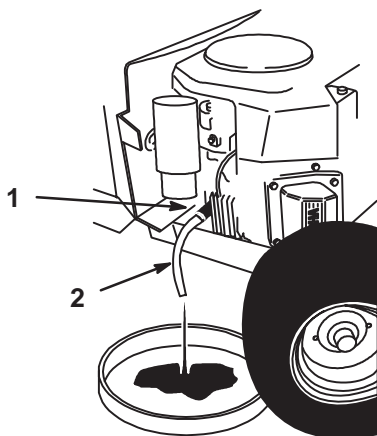

Figure 21

1. Oil drain 2. Hose

7. Slowly pour approximately 80% of the specified amount of oil into the filler tube (Fig. 20). Now check the oil level; refer to Checking Oil Level, page 24. Slowly add additional oil to bring to "FULL" mark on dipstick.

Change Oil Filter

Service Interval/Specification

Replace the oil filter every 200 hours or every other oil change.

Note: Change oil filter more frequently when operating conditions are extremely dusty or sandy.

1. Drain the oil from the engine; refer to Changing/Draining Oil, page 25.
2. Remove the old filter and wipe the filter adapter (Fig. 22) gasket surface.
3. Apply a thin coat of new oil to the rubber gasket on the replacement filter (Fig. 22).

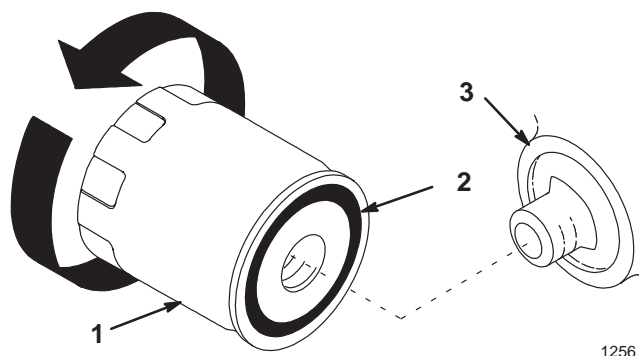

Figure 22

1. Oil filter 3. Adapter
2. Gasket

4. Install the replacement oil filter to the filter adapter. Turn the oil filter clockwise until the rubber gasket contacts the filter adapter, then tighten the filter an additional 1/2 turn (Fig. 22).
5. Fill the crankcase with the proper type of new oil; refer to Changing/Draining Oil, page 25.

Spark Plug

Service Interval/Specification

Check the spark plug(s) after every 200 operating hours. Make sure the air gap between the center and side electrodes is correct before installing the spark plug. Use a spark plug wrench for removing and installing the spark plug(s) and a gapping tool/feeler gauge to check and adjust the air gap.

Type: Champion RC-12YC (or equivalent)

Air Gap: 0.040" (1.02 mm)

Removing the Spark Plug(s)

1. Disengage the power take off (PTO), set the parking brake, and turn the ignition key to "OFF" to stop the engine. Remove the ignition key.
2. Open the hood.
3. Pull the wire(s) off the spark plug(s) (Fig. 23). Now clean around the spark plug(s) to prevent dirt from falling into the engine and potentially causing damage.
4. Remove the spark plug(s).

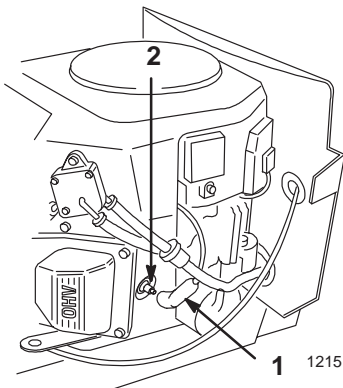

Figure 23

1. Spark plug wire
2. Spark plug

Checking the Spark Plug

1. Look at the center of the spark plug(s) (Fig. 24). If you see light brown or gray on the insulator, the engine is operating properly. A black coating on the insulator usually means the air cleaner is dirty.

IMPORTANT: Never clean the spark plug(s). Always replace the spark plug(s) when it has: a black coating, worn electrodes, an oily film, or cracks.

2. Check the gap between the center and side electrodes (Fig. 24). Bend the side electrode (Fig. 24) if the gap is not correct.

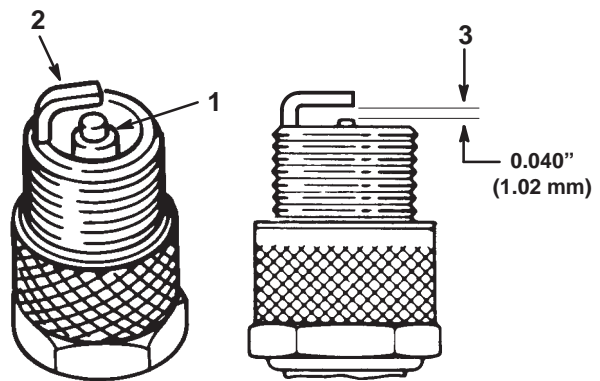

Figure 24

1. Center electrode insulator
2. Side electrode
3. Air gap (not to scale)

Installing the Spark Plug(s)

1. Install the spark plug(s). Make sure the air gap is set correctly.
2. Tighten the spark plug(s) to 20 ft-lb (27 Nm).
3. Push the wire(s) onto the spark plug(s) (Fig. 23).
4. Close the hood.

Greasing and Lubrication

Service Interval/Specification

Grease the machine after every 50 operating hours or yearly, whichever occurs first. Grease more frequently when operating conditions are extremely dusty or sandy.

Grease Type: General-purpose grease.

How to Grease

1. Disengage the power take off (PTO), set the parking brake, and turn the ignition key to “OFF” to stop the engine. Remove the ignition key.
2. Clean the grease fittings with a rag. Make sure to scrape any paint off the front of the fitting(s).
3. Connect a grease gun to the fitting. Pump grease into the fittings until grease begins to ooze out of the bearings.
4. Wipe up any excess grease.

Where to Add Grease

1. Lubricate the front wheels and spindles until grease begins to ooze out of the bearings (Fig. 25).
2. Lubricate the front axle pivot (Fig. 25).

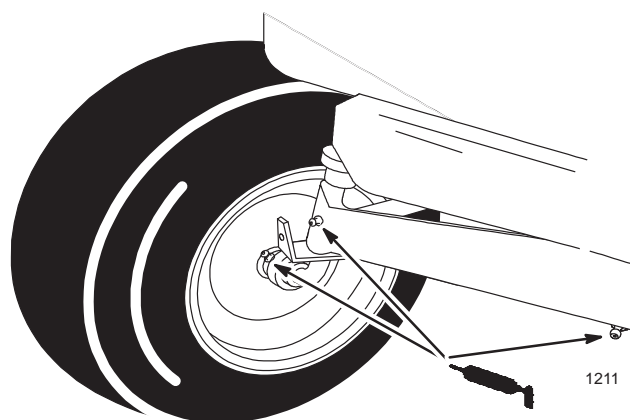

Figure 25

3. Lubricate the traction control pedal on hydrostatic models (or brake and clutch pedals on gear drive models) where they pivot on mounting shaft (Fig. 26).

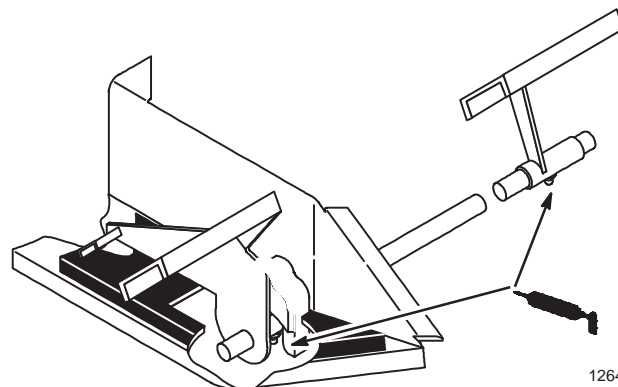

Figure 26

Tire Pressure

Service Interval/Specification

Maintain the air pressure in the front and rear tires as specified. Check the pressure at the valve stem after every 25 operating hours or monthly, whichever occurs first (Fig. 27). Check the tires when they are cold to get the most accurate pressure reading.

Pressure: 20 psi (138 kPa) front and rear

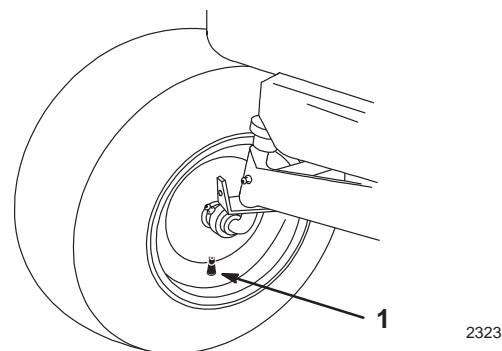

Figure 27

1. Valve stem

Brake

Always set the parking brake when you stop the machine or leave it unattended. If the parking brake does not hold securely, an adjustment is required.

Checking the Brake

1. Park the machine on a level surface, disengage the power take off (PTO), set the parking brake, and turn the ignition key to "OFF" to stop the engine. Remove the ignition key.
2. Rear wheels must lock and skid when you try to push the tractor forward. Adjustment is required if the wheels turn and do not lock; refer to Adjusting the Brake, page 28.
3. Release the brake and move the drive control rod to the "PUSH" position; refer to Pushing the Machine by Hand, page 20. Wheels should rotate freely.
4. If both conditions are met no adjustment is required.

Adjusting the Brake

1. Check the brake before you adjust it; refer to Checking the Brake, page 28.
2. Release the parking brake; refer to Releasing the Parking Brake, page 10.
3. To adjust the brake remove the cotter pin and loosen the brake adjusting nut slightly (Fig. 28).
4. Carefully insert a 0.020" (.51 mm) feeler gauge between the outer brake pad and rotor disk (Fig. 28).
5. Tighten the brake adjusting nut until slight resistance is felt on the feeler gauge when sliding it in and out. Install cotter pin.
6. Check the brake operation again; refer to Checking the Brake, page 28.

IMPORTANT: With the parking brake released, the rear wheels must rotate freely when you push the mower. If the 0.020" (.51 mm) clearance and free wheel rotation cannot be achieved contact your service dealer immediately.

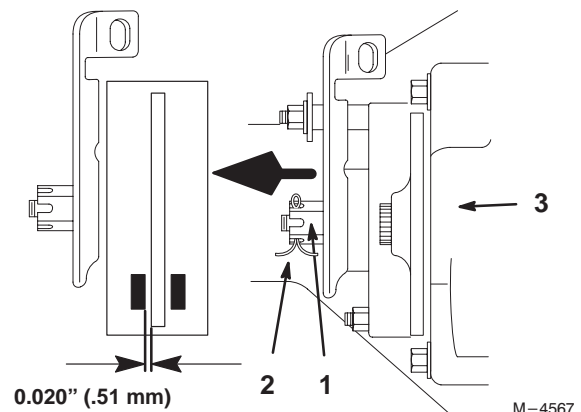

Figure 28

1. Brake adjusting nut
2. Cotter pin
3. Right Front of Transaxle

Fuel Tank

Draining The Fuel Tank

DANGER

POTENTIAL HAZARD

- In certain conditions gasoline is extremely flammable and highly explosive.

WHAT CAN HAPPEN

- A fire or explosion from gasoline can burn you, others, and cause property damage.

HOW TO AVOID THE HAZARD

- Drain gasoline from the fuel tank when the engine is cold. Do this outdoors in an open area. Wipe up any gasoline that spills.
- Never drain gasoline near an open flame or where gasoline fumes may be ignited by a spark.
- Never smoke a cigarette, cigar or pipe.

1. Park the machine on a level surface, to assure fuel tank drains completely. Then disengage the power take off (PTO), set the parking brake, and turn the ignition key to "OFF" to stop the engine. Remove the ignition key.
2. Close fuel shut-off valve at fuel tank (Fig. 29).

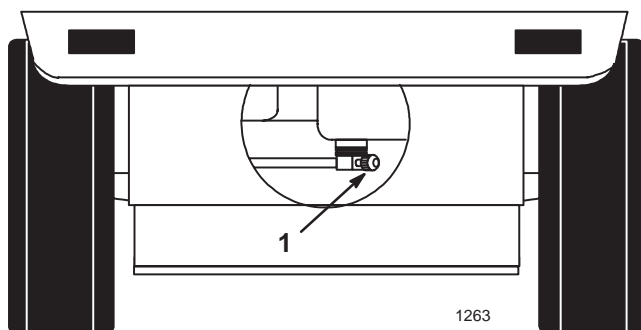

Figure 29

1. Fuel shut-off valve

3. Open the hood.
4. Squeeze the ends of the hose clamp together and slide it up the fuel line toward the fuel tank (Fig. 30).

5. Pull the fuel line off the filter (Fig. 30). Open fuel shut-off valve and allow gasoline to drain into an approved gas can.

Note: Now is the best time to install a new fuel filter because the fuel tank is empty.

6. Install the fuel line onto the filter. Slide the hose clamp close to the filter to secure the fuel line and filter. Refer to Replacing the Fuel Filter; page 30.

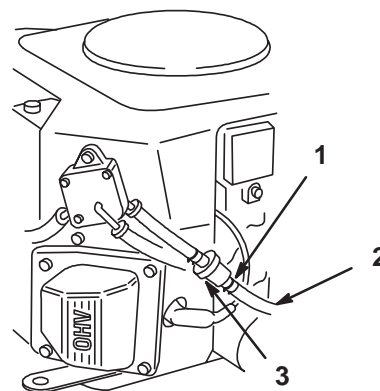

Figure 30

1. Hose clamp
2. Fuel line
3. Filter

1217

Fuel Filter

Service Interval/Specification

Replace the fuel filter after every 100 operating hours or yearly, whichever occurs first.

Replacing the Fuel Filter

Never install a dirty filter if it is removed from the fuel line.

1. Disengage the power take off (PTO), set the parking brake, and turn the ignition key to “OFF” to stop the engine. Remove the ignition key.
2. Close fuel shut-off valve at fuel tank (Fig. 29).
3. Open the hood.
4. Squeeze the ends of the hose clamps together and slide them away from the filter (Fig. 31).
5. Remove the filter from the fuel lines.

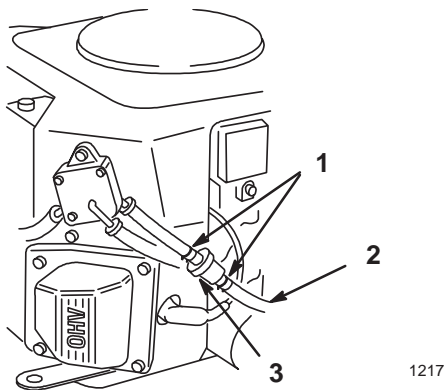

Figure 31

- | | |
|---------------|-----------|
| 1. Hose clamp | 3. Filter |
| 2. Fuel line | |

-
6. Install a new filter and move the hose clamps close to the filter.
 7. Open fuel shut-off valve at fuel tank (Fig. 29).
 8. Close the hood.

Front Wheel Toe-In

Service Interval/Specification

Maintain toe-in of the front wheels as specified. If uneven tire wear, lawn scuffing or hard steering develop adjustment may be required. Check the toe-in after every 100 operating hours or yearly, whichever occurs first (Fig. 32).

Specification: 1/8–1/4 inch toe-in on front wheels.

Measuring Toe-in

1. Disengage the power take off (PTO), set the parking brake, and turn the ignition key to “OFF” to stop the engine. Remove the ignition key.
2. Push front tires out, at front, to remove normal looseness in the linkage.
3. Measure, between the rims, at spindle level, in the front and rear of the wheels (Fig. 32).
4. The front measurement should be less than the rear, as specified.

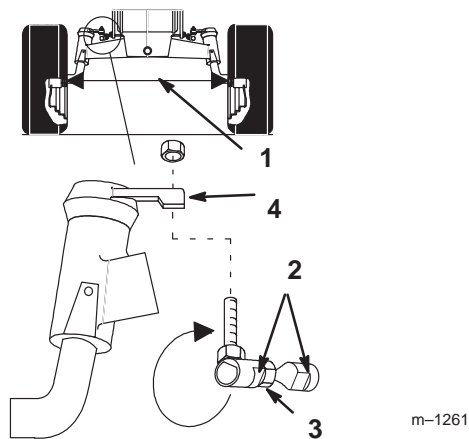

Figure 32

- | | |
|-----------------|-------------------|
| 1. Measure here | 3. Jam nut |
| 2. Flats | 4. Steering lever |

Adjusting Toe-In

1. Check the toe-in before you adjust it; refer to Measuring Toe-In, Page 31.
2. Remove ball joint from one steering lever (Fig. 32).
3. Loosen jam nut securing ball joint to steering rod. Rotate ball joint one turn, clockwise to increase or counter clockwise to decrease toe-in.
4. Hold flats on ball joint to align with flats on tie rod and tighten jam nut (Fig. 32).
5. Install ball joint to steering lever and check the toe-in; refer to Measuring Toe-In, Page 32.

IMPORTANT: If more than one turn is required to meet specifications, alternate between left and right steering rods to maintain steering wheel alignment.

Transaxle Fluid

Service Interval/Specification

The transaxle is a sealed system and no checking or changing of the fluid is required.

IMPORTANT: If any transaxle problems arise, contact your local Authorized Service Dealer for help and service.

Fuse

Service Interval/Specification

The electrical system is protected by fuses. It requires no maintenance, however, if a fuse blows check component/circuit for malfunction or short. To replace fuses pull up on the fuse (Fig. 33) to remove or replace it.

Fuse: Main/Starter F1–30 amp, blade-type
Regulator F2–25 amp, blade-type
Dash F3–10 amp, blade-type
Head lights F4–10 amp, blade-type

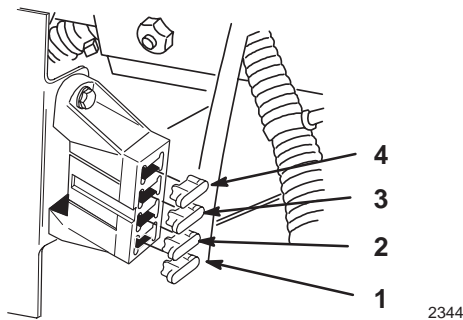

Figure 33

- | | |
|-----------------------|---------------------|
| 1. Dash-10 Amp | 3. Regulator-25 amp |
| 2. Head lights-10 amp | 4. Main-30 amp |

Headlights

Specification: Bulb # 1156 Automotive Type

Removing the Bulb

1. Disengage the power take off (PTO), set the parking brake, and turn the ignition key to “OFF” to stop the engine. Remove the ignition key.
2. Open the hood. Pull wire connectors off both bulb holder terminals.
3. Rotate the bulb holder 1/4 turn counterclockwise and remove it from the reflector (Fig. 34).
4. Push and rotate the bulb counterclockwise until it stops (approx. 1/4 turn) and remove bulb from the bulb holder (Fig. 35).

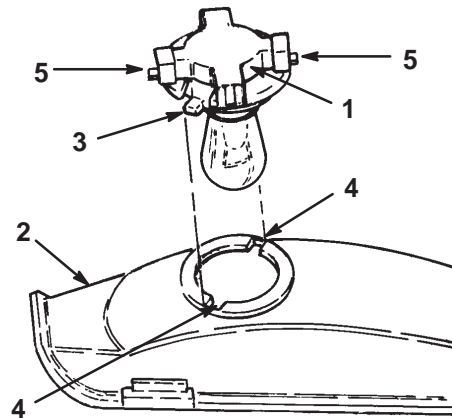

Figure 34

- | | |
|----------------|--------------|
| 1. Bulb holder | 4. Slots |
| 2. Reflector | 5. Terminals |
| 3. Tabs | |

Installing the Bulb

1. The bulb has metal pins on the side of its base. Align the pins with the slots in the bulb holder and insert the base into the holder (Fig. 35). Push and rotate the bulb clockwise until it stops.

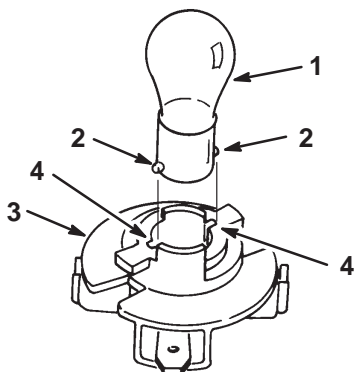

Figure 35

- | | |
|---------------|----------------|
| 1. Bulb | 3. Bulb holder |
| 2. Metal pins | 4. Slots |

2. The bulb holder has two tabs (Fig. 34). Align the tabs with the slots in the reflector, insert the bulb holder into the reflector and rotate it 1/4 turn clockwise until it stops.
3. Push the wire connectors onto the terminals on the bulb holder.

Battery

Service Interval/Specification

Check the electrolyte level in the battery every 5 hours. Always keep the battery clean and fully charged. Use a paper towel to clean the battery case. If the battery terminals are corroded, clean them with a solution of four parts water and one part baking soda. Apply a light coating of grease to the battery terminals to prevent corrosion.

Voltage: 12 v, 180 Cold Cranking Amps

Removing the Battery

1. Disengage the power take off (PTO), set the parking brake, and turn the ignition key to "OFF" to stop the engine. Remove the ignition key.
2. Open the hood to see the battery.
3. Remove side panels for clearance when removing battery (Fig. 37). Remove the wing nuts and screws and lift up to clear pin and slide panel tabs out from steering tower.
4. Disconnect the negative (black) ground cable from the battery post (Fig. 36).
5. Lift the rubber cover up on the positive (red) cable. Disconnect the positive (red) cable from the battery post (Fig. 36).
6. Remove the battery hold down rods (Fig. 36).

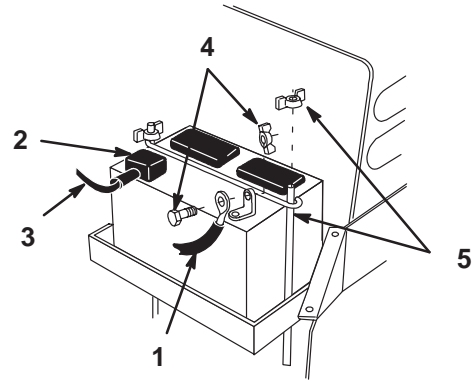

1219

Figure 36

- | | |
|---------------------------|-------------------------------|
| 1. Negative cable (black) | 4. Bolt and wing nut |
| 2. Rubber cover | 5. Hold down rod and wing nut |
| 3. Positive cable (red) | |

Installing the Battery

7. Install the battery into the chassis (Fig. 37).
8. Secure battery in chassis with hold down rods.
9. Using the bolt and wing nut, connect the positive (red) cable to the positive (+) battery post (Fig. 36). Slide the rubber cover over the battery post.
10. Using the bolt and wing nut, connect the negative (black) cable to the negative (-) battery post (Fig. 36).
11. Install side panels by sliding tabs into steering tower and inserting pin into flange of footrest. Secure with screws and wing nuts (Fig. 37).

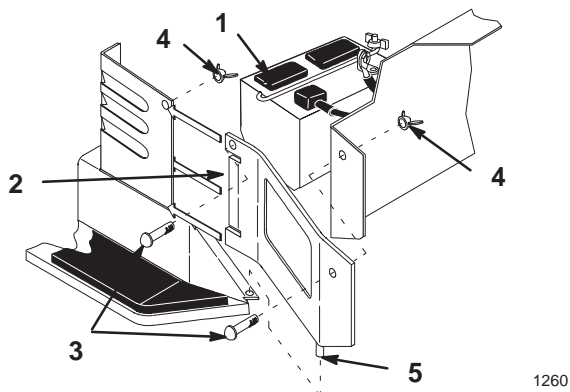

Figure 37

- | | |
|--------------------|-------------|
| 1. Battery | 4. Wing nut |
| 2. Side panel tabs | 5. Pin |
| 3. Screw | |

Checking Electrolyte Level

1. With the engine off, open the hood to see the battery.
2. Open covers to see into the cells. The electrolyte must be up to the lower part of the tube (Fig. 38). Do not allow the electrolyte to get below the plates. (Fig. 38).
3. If the electrolyte is low, add the required amount of distilled water; refer to Adding Water to the Battery, page 35.

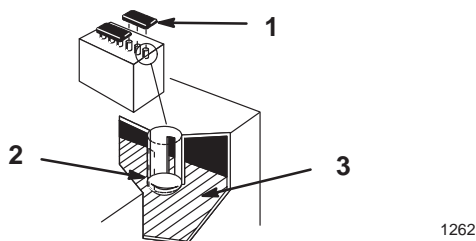

Figure 38

- | | |
|-----------------------|-----------|
| 1. Filler caps | 3. Plates |
| 2. Lower part of tube | |

Adding Water to the Battery

The best time to add distilled water to the battery is just before you operate the machine. This lets the water mix thoroughly with the electrolyte solution.

1. Clean the top of the battery with a paper towel.
 2. Lift off the filler caps (Fig. 38).
 3. Slowly pour distilled water into each battery cell until the level is up to the lower part of the tube (Fig. 38).
- IMPORTANT: Do not overfill the battery because electrolyte (sulfuric acid) can cause severe corrosion and damage to the chassis.**
4. Press the filler caps onto the battery.

Charging the Battery

IMPORTANT: Always keep the battery fully charged (1.260 specific gravity). This is especially important to prevent battery damage when the temperature is below 32°F (0°C).

1. Remove the battery from the chassis; refer to Removing the Battery, page 34.
2. Check the electrolyte level; refer to Checking Electrolyte Level, page 35, steps 2–3.
3. Remove the filler caps from the battery and connect a 3 to 4 amp battery charger to the battery posts. Charge the battery at a rate of 4 amperes or less for 4 hours (12 volts). Do not overcharge the battery. Install the filler caps after the battery is fully charged.

WARNING

POTENTIAL HAZARD

- Charging the battery produces gasses.

WHAT CAN HAPPEN

- Battery gasses can explode.

HOW TO AVOID THE HAZARD

- Keep cigarettes, sparks and flames away from battery.

4. Install the battery in the chassis; refer to Installing the Battery, page 34.

Wiring Diagram

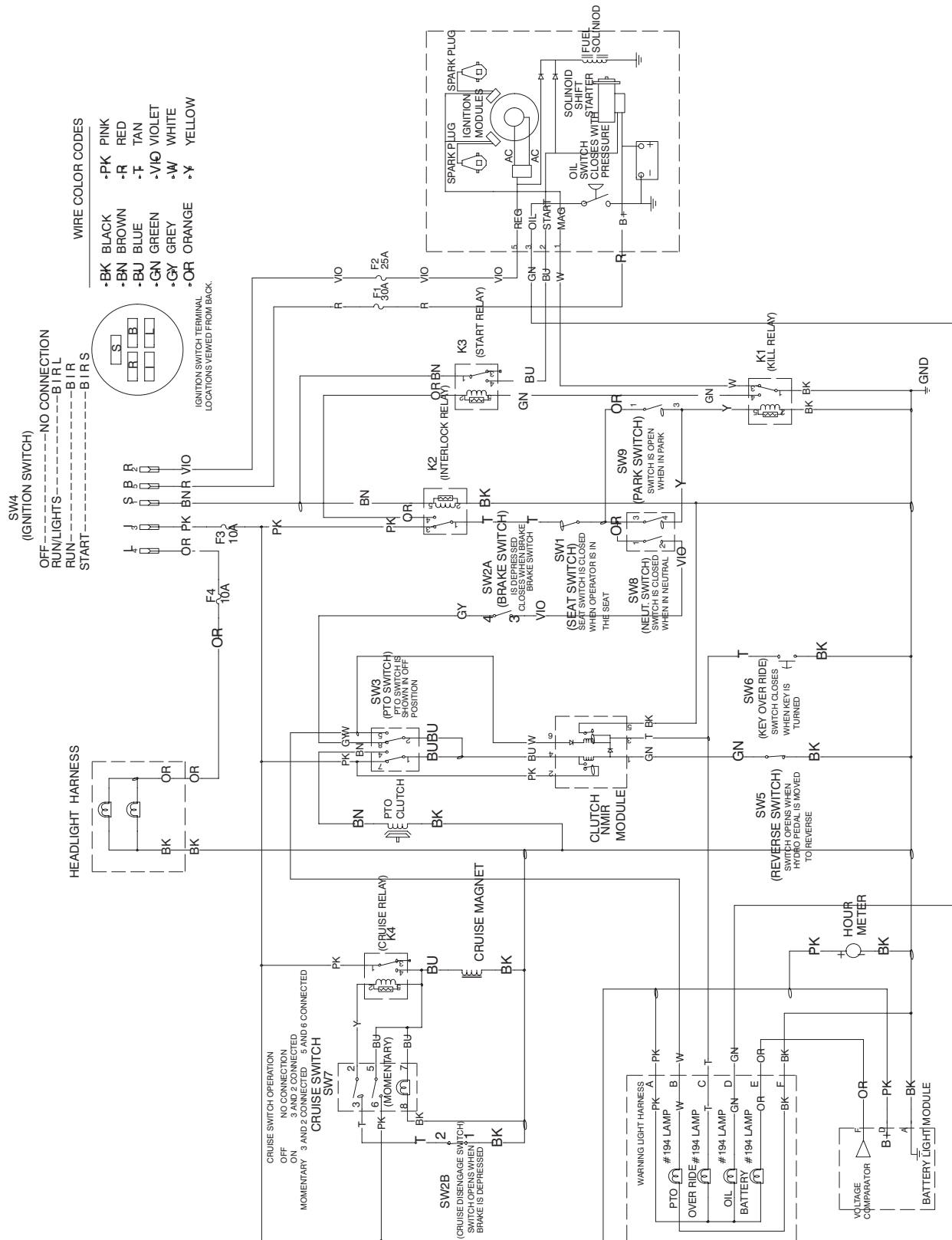

Cleaning and Storage

1. Disengage the power take off (PTO), set the parking brake, and turn the ignition key to “OFF” to stop the engine. Remove the ignition and “Key Choice” keys.
2. Remove grass clippings, dirt, and grime from the external parts of the entire machine, especially the engine. Clean dirt and chaff from the outside of the engine’s cylinder head fins and blower housing.
IMPORTANT: You can wash the machine with mild detergent and water. Do not pressure wash the machine. Avoid excessive use of water, especially near the control panel, lights, engine, and the battery.
3. Check the brake; refer to Brake, page 27.
4. Service the air cleaner; refer to Air Cleaner, page 22.
5. Grease the chassis; refer to Greasing and Lubrication, page 27.
6. Change the crankcase oil; refer to Engine Oil, page 24.
7. Remove the spark plug(s) and check its condition; refer to Spark Plug, page 26. With the spark plug(s) removed from the engine, pour two tablespoons of engine oil into the spark plug hole. Now use the electric starter to crank the engine and distribute the oil inside the cylinder. Install the spark plug(s) and tighten it to 30 ft–lb (40 Nm). Do not install the wire on the spark plug(s).

8. Remove the battery from the chassis, check the electrolyte level, and charge it fully; refer to Battery, page 34. Do not connect the battery cables to the battery posts during storage.

IMPORTANT: The battery must be fully charged to prevent it from freezing and being damaged at temperatures below 32°F (0°C). A fully charged battery maintains its charge for about 50 days at temperatures lower than 40°F (4°C). If the temperatures will be above 40°F (4°C), check the water level in the battery and charge it every 30 days.

9. Check the tire pressure; refer to Tire Pressure, page 27.
10. Prepare the machine for storage when non-use occurs over 30 days. Prepare machine for storage as follows.
 - A. Add a petroleum based stabilizer/conditioner to fuel in the tank. Follow mixing instructions from stabilizer manufacture. **Do not use an alcohol based stabilizer (ethanol or methanol).**

Note: A fuel stabilizer/conditioner is most effective when mixed with fresh gasoline and used at all times.

 - B. Run engine to distribute conditioned fuel through the fuel system (5 minutes).
 - C. Stop engine, allow to cool and drain the fuel tank; refer to Fuel Tank, page 29.
 - D. Restart engine and run it until it stops.
 - E. Choke or prime the engine. Start and run engine until it will not start. Operate primer, if equipped on machine, several times to ensure no fuel remains in primer system.
 - F. Dispose of fuel properly. Recycle as per local codes.

IMPORTANT: Do not store stabilizer/conditioned gasoline over 90 days.

- 11.** Check and tighten all bolts, nuts, and screws. Repair or replace any part that is damaged or defective.
- 12.** Paint all scratched or bare metal surfaces. Paint is available from your Authorized Service Dealer.
- 13.** Store the machine in a clean, dry garage or storage area. Remove the keys from the ignition and “Key Choice” switches and keep it in a memorable place. Cover the machine to protect it and keep it clean.

Troubleshooting

PROBLEM	POSSIBLE CAUSES	CORRECTIVE ACTION
Starter does not crank	<ol style="list-style-type: none"> 1. Blade control (PTO) is ENGAGED. 2. Parking brake is not on. 3. Operator is not seated. 4. Battery is dead. 5. Electrical connections are corroded or loose. 6. Fuse is blown. 7. Relay or switch is defective. 	<ol style="list-style-type: none"> 1. Move blade control (PTO) to DISENGAGED. 2. Set parking brake. 3. Sit on the seat. 4. Charge the battery. 5. Check electrical connections for good contact. 6. Replace fuse. 7. Contact Authorized Service Dealer.
Engine will not start, starts hard, or fails to keep running.	<ol style="list-style-type: none"> 1. Fuel tank is empty. 2. Choke is not ON. 3. Air cleaner is dirty. 4. Spark plug wire is loose or disconnected. 5. Spark plug is pitted, fouled, or gap is incorrect. 6. Dirt in fuel filter. 7. Dirt, water, or stale fuel is in fuel system. 	<ol style="list-style-type: none"> 1. Fill fuel tank with gasoline. 2. Move choke lever to ON. 3. Clean or replace air cleaner element. 4. Install wire on spark plug. 5. Install new, correctly gapped spark plug. 6. Replace fuel filter. 7. Contact Authorized Service Dealer.
Engine loses power.	<ol style="list-style-type: none"> 1. Engine load is excessive. 2. Air cleaner is dirty. 3. Oil level in crankcase is low. 4. Cooling fins and air passages under engine blower housing are plugged. 5. Spark plug is pitted, fouled, or gap is incorrect. 6. Vent hole in fuel cap is plugged. 7. Dirt in fuel filter. 8. Dirt, water, or stale fuel is in fuel system. 	<ol style="list-style-type: none"> 1. Reduce ground speed. 2. Clean air cleaner element. 3. Add oil to crankcase. 4. Remove obstruction from cooling fins and air passages. 5. Install new, correctly gapped spark plug. 6. Clean or replace the fuel cap. 7. Replace fuel filter. 8. Contact Authorized Service Dealer.

PROBLEM	POSSIBLE CAUSES	CORRECTIVE ACTION
Engine overheats.	<ol style="list-style-type: none"> 1. Engine load is excessive. 2. Oil level in crankcase is low. 3. Cooling fins and air passages under engine blower housing are plugged. 	<ol style="list-style-type: none"> 1. Reduce ground speed. 2. Add oil to crankcase. 3. Remove obstruction from cooling fins and air passages.
Abnormal vibration.	<ol style="list-style-type: none"> 1. Engine mounting bolts are loose. 2. Loose engine pulley, idler pulley, or blade pulley. 3. Engine pulley is damaged. 	<ol style="list-style-type: none"> 1. Tighten engine mounting bolts. 2. Tighten the appropriate pulley. 3. Contact Authorized Service Dealer.
Machine does not drive.	<ol style="list-style-type: none"> 1. Drive control is in "PUSH" position. 2. Traction belt is worn, loose or broken. 3. Traction belt is off pulley. 	<ol style="list-style-type: none"> 1. Move drive control to "OPERATE" position. 2. Contact Authorized Service Dealer. 3. Contact Authorized Service Dealer.



Consumer Riding Products

THE TORO TOTAL COVERAGE GUARANTEE

A Full Two-Year Warranty

(Limited Warranty For Commercial Use)

What Is Covered By This Express Warranty?

The Toro Company promises to repair any TORO Product used for normal residential purposes* if defective in materials or workmanship for a period of two years from the date of purchase with the following exceptions:

- Batteries are warranted for one year

This warranty covers the cost of parts and labor as well as transportation within a 15 mile radius of the servicing dealer.

What Products Are Covered By This Warranty?

This warranty applies to all consumer riding products and their attachments.

How About Commercial Use?

TORO Consumer Products and attachments used for commercial, institutional or rental use are covered by a limited warranty for the following time periods from the date of purchase:

Products	Warranty Period
• 300 and 5xi Series Tractors	
Chassis	1 year limited warranty
Liquid Cooled Gas Engines .	1 year limited warranty
Air Cooled Gas and Diesel Engines	2 year limited warranty
• All Others	90 day limited warranty

How Do You Get Warranty Service?

Should you feel your TORO Product contains a defect in material or workmanship, contact the dealer who sold you the product or any Authorized TORO Service Dealer or TORO Master Service Dealer. The Yellow Pages of your telephone directory is a good reference source. The dealer will either arrange service at his/her dealership or recommend another Authorized Service Dealer who may be more convenient. You may need proof of purchase (copy of registration card, sales receipt, etc.) for warranty validation.

If for any reason you are dissatisfied with the Service Dealer's analysis of the defect in materials or workmanship or if you need a referral to a TORO Service Dealer, please feel free to contact us at the following address:

Toro Customer Service Department
8111 Lyndale Avenue South
Bloomington, MN 55420-1196
612-888-8801
800-348-2424

What Must You Do To Keep The Warranty In Effect?

You must maintain your TORO Product by following the maintenance procedures described in the operator's manual. Such routine maintenance, whether performed by a dealer or by you, is at your expense.

What Does This Warranty Not Cover? and

How Does Your State Law Relate To This Warranty?

There is no other express warranty except for special emission system coverage on some products. This express warranty does not cover:

- Cost of regular maintenance service or parts, such as filters, fuel, lubricants, tune-up parts, blade sharpening, brake and clutch adjustments.
- Any product or part which has been altered or misused or required replacement or repair due to normal wear, accidents, or lack of proper maintenance.
- Repairs necessary due to improper fuel, contaminants in the fuel system, or failure to properly prepare the fuel system prior to any period of non-use over three months.
- Pickup and delivery charges for distances beyond a 15 mile radius from an Authorized TORO Service Dealer.

All repairs covered by this warranty must be performed by an Authorized TORO Service Dealer using Toro approved replacement parts.

Repair by an Authorized TORO Service Dealer is your sole remedy under this warranty.

The Toro Company is not liable for indirect, incidental or consequential damages in connection with the use of the TORO Products covered by this warranty, including any cost or expense of providing substitute equipment or service during reasonable periods of malfunction or non-use pending completion of repairs under this warranty. Some states do not allow exclusions of incidental or consequential damages, so the above exclusion may not apply to you.

This warranty gives you specific legal rights, and you may also have other rights which vary from state to state.

* Normal residential purposes means mowing the lawn on the same lot as your home. Use at more than one location is considered commercial use and the commercial use warranty would apply.

COUNTRIES OTHER THAN THE UNITED STATES OR CANADA

Customers who have purchased TORO Products exported from the United States or Canada should contact their TORO Distributor (Dealer) to obtain guarantee policies for your country, province, or state. If for any reason you are dissatisfied with your Distributor's service or have difficulty obtaining guarantee information, contact the TORO importer. If all other remedies fail, you may contact us at The Toro Company.