



Dingo 222
Compact Utility Loader
Model No. 22304—200000001 and Up

Parts Catalog

Ordering Replacement Parts

To order replacement parts, please supply: the part number, the quantity, and the description of each part desired.

Understanding Reference Numbers

Each identified part in an illustration has a reference number. The reference number for a part also appears in the parts list, along with other information about the part.

This catalog uses two special reference number formats, one to indicate parts in a service assembly and another to indicate the quantity of a given part in an illustration.

Service Assembly Reference Numbers

Parts in service assemblies have reference numbers in the form **a:b**. The **a** represents the reference number of the entire service assembly and the **b** represents a sequential number unique to each part within the service assembly.

For example, a wheel assembly might be identified by reference number **6**, the tire by **6:1**, the valve by **6:2**, and the wheel by **6:3**. When you order the assembly identified by reference number **6**, you receive all parts identified by reference numbers **6:1**, **6:2**, and **6:3**. However, you may also order any part individually.

Reference numbers of this type appear in illustrations and in part lists.

Reference Numbers Indicating Quantity

In an illustration, if a reference number indicates more than one part, the reference number has the form **nX y**. The **n** represents the quantity of the part, the **X** is the multiplication symbol, and the **y** represents the reference number.

For example, in an illustration, the reference number **2X 37** means that two of the parts identified by reference number **37** are indicated.

Contents

Description	Page	Description	Page
Frame and Loader Arm Assembly	3	Hydraulic Valve Assembly No. 99-3077	14
Front Wheel Assembly	4	Hydraulic Cylinder Assembly	15
Rear Wheel Assembly	5	Kit-Hydraulic Cylinder No. 100-4163	16
Hydraulic Motor Assembly No. 99-3052	6	Hydraulic Assembly	17
Engine Assembly	7	Decal Locations	18
Hydraulic Assembly	8-10	Electrical Assembly	19
Hydraulic Valve Assembly No. 99-3073	11	Electrical Schematic	20
Hydraulic Valve Assembly No. 99-3072	12	Hydraulic Schematic	21
Hydraulic Valve Assembly No. 98-4732	13	Engine Assembly	22-32

Part Description Abbreviations

Part descriptions in this catalog may include the following abbreviations.

Abbreviation	Meaning	Abbreviation	Meaning
AR	as required	INC	incorporated
ASM	assembly	LH	left hand
CARR	carriage	NI	nylon insert
DEG	degrees	PPH	Phillips pan head
FH	flat head	PTH	Phillips truss head
GA	gauge	PTO	power take off
HF	hex flange	RH	right hand
HH	hex head	SFH	slotted fillister head
HHF	hex head flange	SHH	slotted hex head
HLH	hex lag head	SQH	square head
HJ	hex jam	SHWH	slotted hex washer head
HOC	height-of-cut	SPH	slotted pan head
HS	hex socket	SRH	slotted round head
HSBH	hex socket button head	STD	standard
HSFH	hex socket flat head	TAP	self tapping
HSH	hex socket head	TTH	Torx truss head
HWH	hex washer head	WH	wing head
HWHTF	hex washer head thread forming		

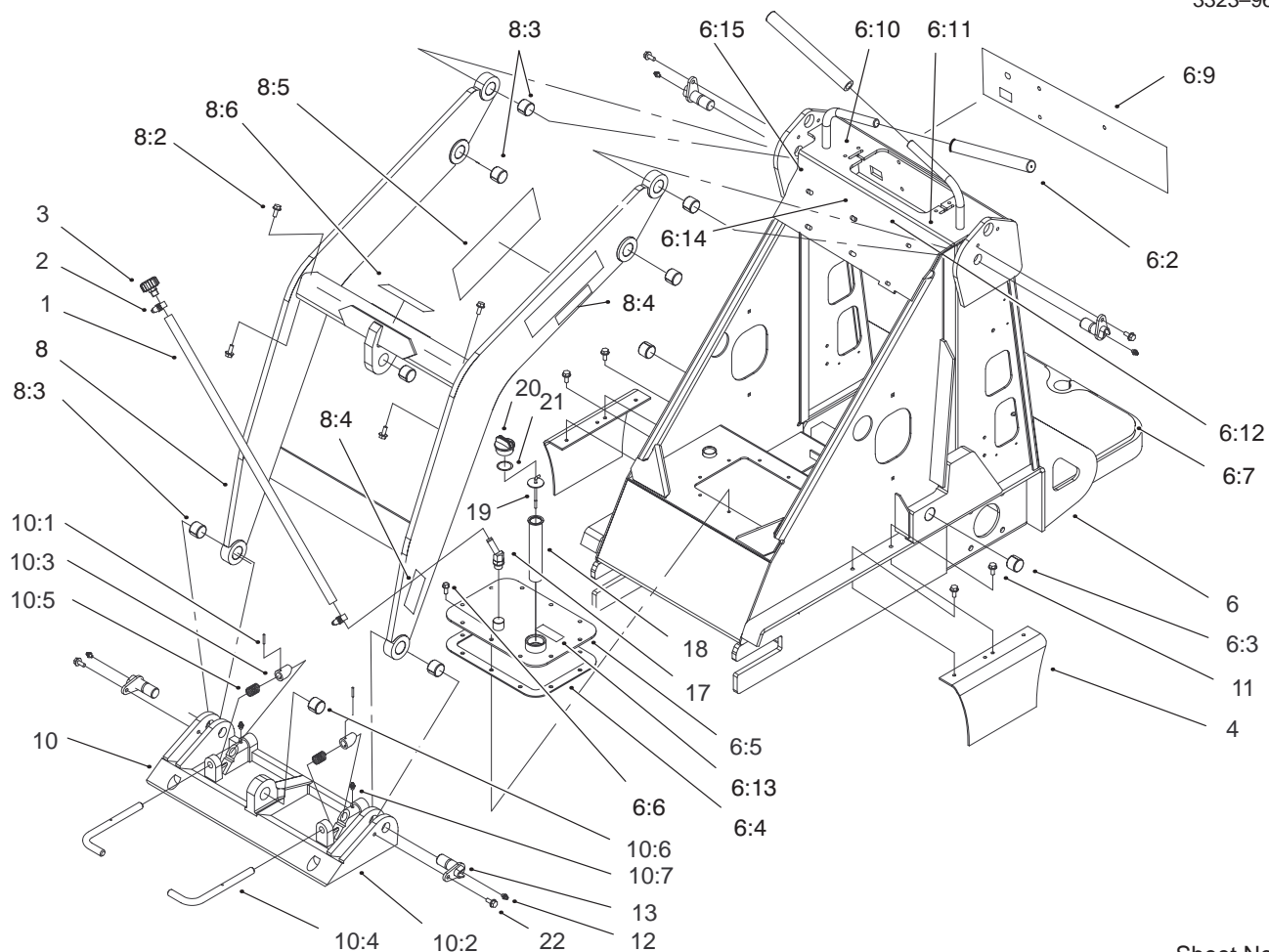

Sheet No.: 2

Frame and Loader Arm Assembly

Ref. No.	Part No.	Qty.	Description	Ref. No.	Part No.	Qty.	Description
1	98-2708	1	Hose-Vent	10:2	98-4691	1	Mount-Quick Attach
2	2412-36	2	Clamp-Hose	10:3	98-4692	2	Cam-Quick Attach
3	68-6150	1	Breather-Air	10:4	100-3373	2	Pin-Quick Attach
4	98-4669	2	Cover-Chain	10:5	98-4694	2	Spring-Compression
6	99-1355	1	Frame ASM	10:6	98-4871	1	Bushing-Tension
6:2	98-4845	2	Grip-Cushion	10:7	302-5	2	Fitting-Grease
6:3	98-4871	2	Bushing-Tension	11	32144-70	8	Screw-TAP
6:4	98-9927	1	Gasket-Cover	12	302-5	10	Fitting-Grease
6:5	98-2709	1	Cover	13	99-1414	10	Pivot Pin
6:6	98-9940	10	Screw	17	354-126	1	Fitting-Barb
6:7	98-9947	2	Tread	18	61-2790	1	Filler-Screen
6:9	99-1385	1	Decal-Control Panel	19	99-1351	1	Dipstick-Oil
6:10	94-2551	1	Decal-Choke	20	93-7498	1	Plug-Plastic
6:11	98-8219	1	Decal-Throttle	21	237-123	1	O-Ring
6:12	98-8220	1	Decal-Speed Limiter	22	99-5105	10	Bolt-Shoulder
6:13	85-4730	1	Decal-Hyd. Oil Only				
6:14	98-8235	1	Decal-Selector				
6:15	98-4677	1	Decal-Aux. Power				
8	100-8814	1	Loader ASM				
8:2	32144-70	2	Screw-TAP				
8:3	98-4871	7	Bushing-Tension				
8:4	100-6141	4	Decal-Warning				
8:5	98-9051	1	Decal-Danger				
8:6	98-4682	1	Decal-Caution				
10	98-4690	1	Quick Attach ASM				
10:1	32121-94	2	Pin-Spirol				

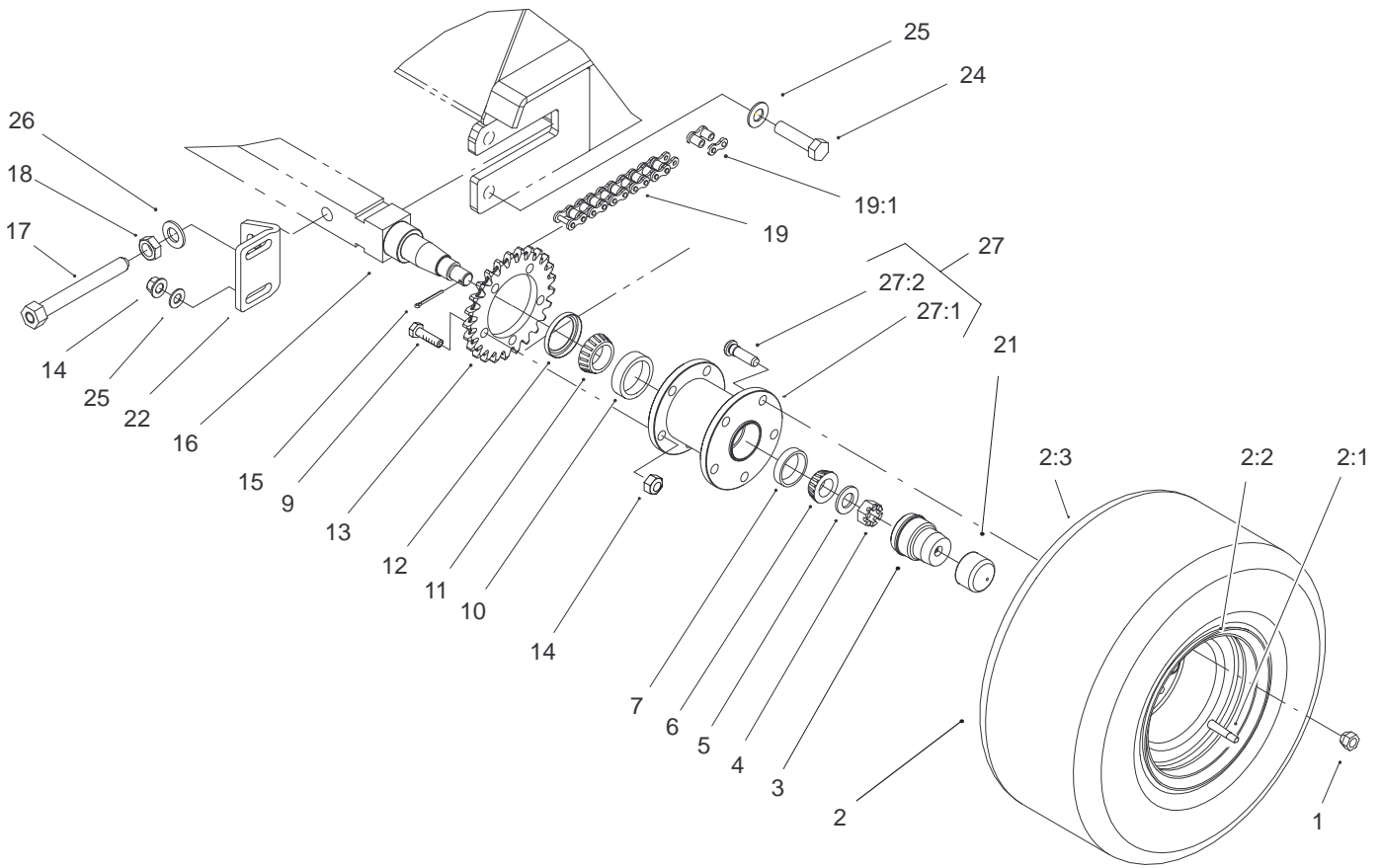

Sheet No.:3

Front Wheel Assembly

Ref. No.	Part No.	Qty.	Description
1	242-50	20	Nut-Lug
2	98-4709	4	Tire And Wheel ASM
2:1	106396	4	Tube
2:2	98-4753	4	Wheel
2:3	98-4757	4	Tire
3	95-7152	2	Protector-Bearing
4	32136-5	2	Nut-Hex Slot
5	3256-28	2	Washer-Flat
6	254-94	2	Cone-Bearing
7	254-72	2	Cup-Bearing
9	325-7	20	Screw-HH
10	254-107	2	Inner Bearing Cup
11	254-106	2	Inner Bearing Cone
12	98-4705	2	Seal-Wheel Bearing
13	98-9937-01	4	Sprocket-25 Tooth
14	3296-23	24	Nut-Lock
15	3272-12	2	Pin-Cotter
16	98-4825	1	Axle-Front
17	98-4706	2	Tension Bolt
18	3218-7	2	Jam Nut
19	98-4906	2	Chain-Roller
19:1	98-9089	2	Link-Connecting
21	99-1384	2	Boot-Protector
22	99-5106-03	2	Bracket-Axle
24	325-8	4	Screw-HH
25	3256-26	8	Washer-Flat

Ref. No.	Part No.	Qty.	Description
26	3256-28	2	Washer-Flat
27	100-9989	2	Hub ASM-Front
27:1	98-4823-03	2	Hub-Front
27:2	10-6830	20	Stud-Drive Type

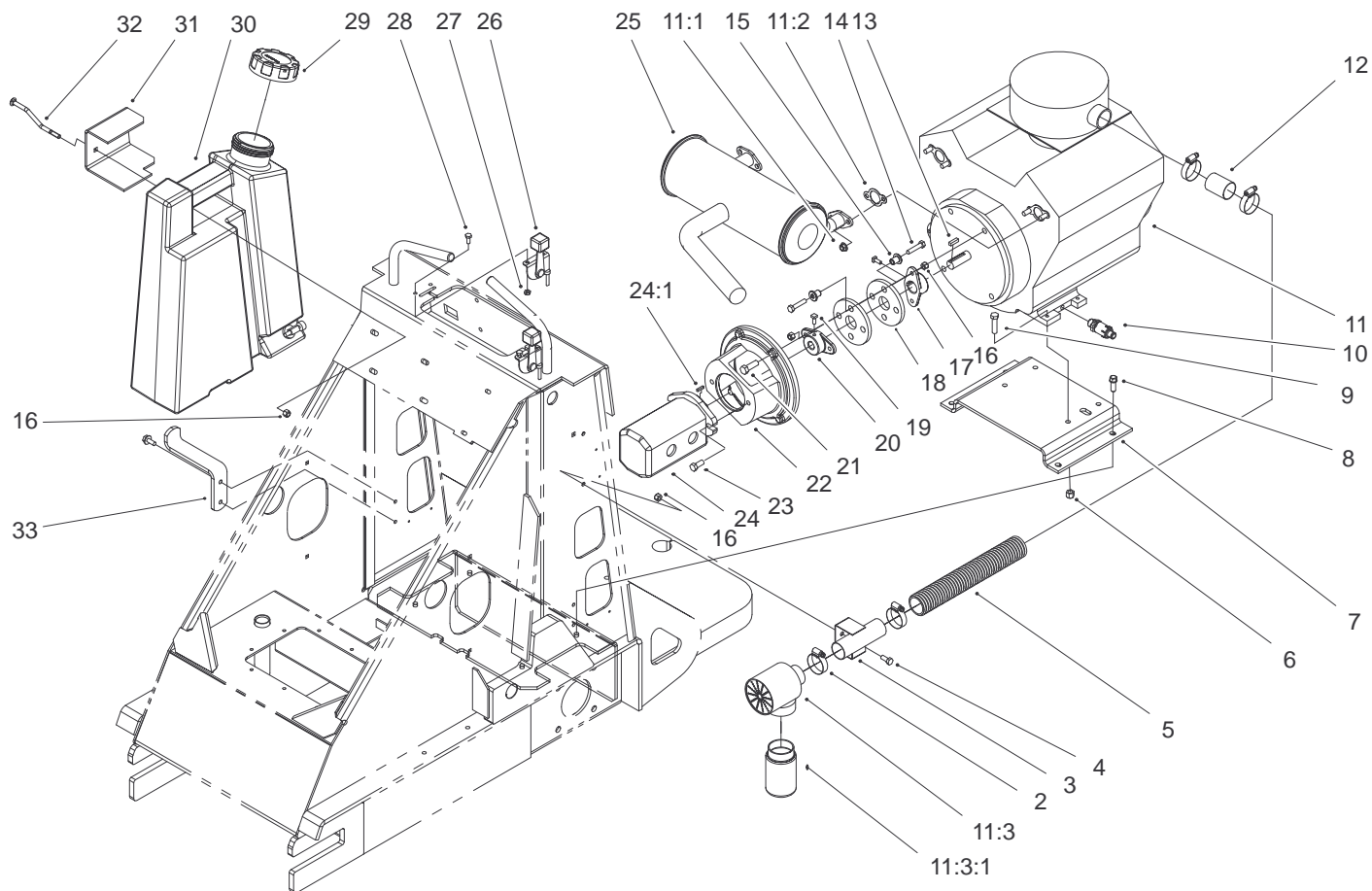

Sheet No.:5

Engine Assembly

Ref. No.	Part No.	Qty.	Description
2	2412-111	4	Clamp
3	98-9945	1	Tube ASM
4	322-3	1	Screw-HH
5	98-9073	1	Hose-Air
6	3296-39	4	Nut-Lock
7	98-4666	1	Mount-Engine
8	95-1726	4	Screw-Engine Mount
9	323-9	4	Screw-HH
10	92-6877	1	Valve-Oil Drain
11		1	Engine (CH22S 66551) Kohler 22 Hp.
11:1	92-6780	4	Nut-HHF
11:2	93-0350	2	Gasket-Exhaust
11:3	98-9903	1	Precleaner-Kohler
11:3:1	98-9904	1	Jar-Precleaner
12	98-9075	1	Tube-Air
13	10-7070	1	Key-Square
14	322-7	4	Screw-HH
15	71-4411	4	Spacer-Coupling
16	3296-29	17	Nut-Lock
17	27-1960	1	Hub-Engine
18	44-2230	2	Coupling-Rubber
19	3241-6	4	Set Screw
20	98-4701	1	Hub-Pump
21	324-6	4	Screw-HH
22	98-2751	1	Mount-Pump

Ref. No.	Part No.	Qty.	Description
23	66-9300	2	Screw-HWH
24	98-4702	1	Pump-Gear
24:1	98-4700	1	Key-Square
*24:2	99-1353	1	Seal Kit-Pump
25	100-1711	1	Muffler-Kohler 22
*25:1	98-9099	1	Spark Arrestor (Optional)
26	85-9310	2	Control-Choke
27	3296-42	4	Nut-Lock
28	3234-33	4	Screw-HFW
29	88-3980	1	Gas Cap ASM
30	98-4654	1	Fuel Tank ASM
*30:1	104047	1	Bushing
*30:2	104048	1	Valve-Fuel
31	98-4655	1	Plate
32	98-4657	1	Bolt-Mount
33	98-4656	1	Mount-Tank
*	2412-98	2	Clamp-Hose
*	98-4667	1	Hose-Drain
*	98-4668	1	Line-Fuel

* Not illustrated

3323-969

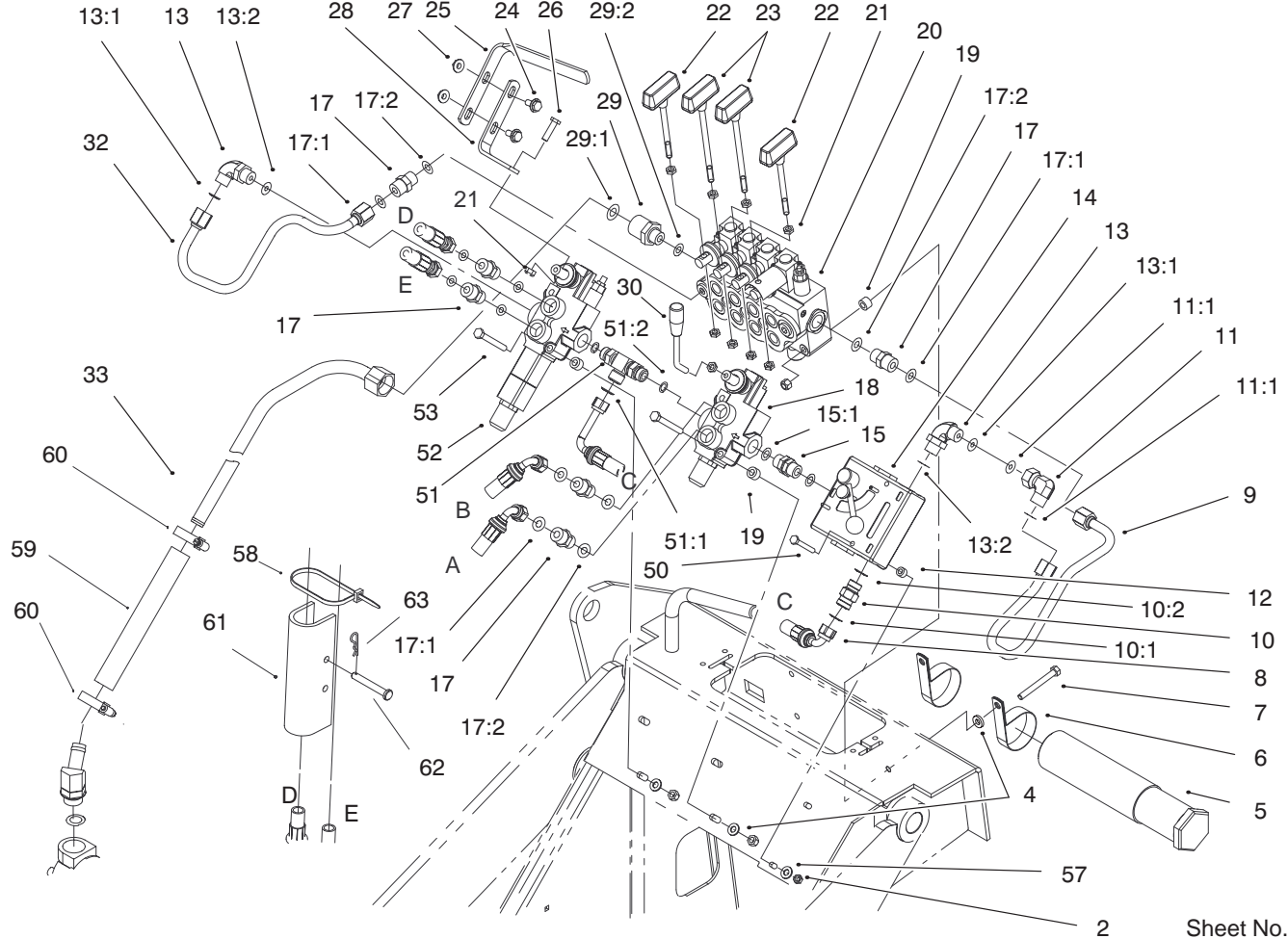

Sheet No.:6

Hydraulic Assembly

Ref. No.	Part No.	Qty.	Description
2	3296-42	2	Nut-Lock
4	3256-23	7	Washer-Flat
5	74-0720	1	Tube-Manual
6	2412-133	2	R-Clamp
7	322-20	3	Screw-HH
8	98-4744	1	Hose ASM
9	98-9917	1	Line-Hyd
10	98-4735	1	Valve-Hyd
10:1	237-30	1	O-Ring
10:2	237-79	1	O-Ring
11	94-6031	1	Fitting-Hyd
11:1	237-30	2	O-Ring
12	98-4799	2	Tube-Spacer
13	340-98	2	Fitting-Hyd
13:1	237-30	2	O-Ring
13:2	237-79	2	O-Ring
14	99-3073	1	Valve-Hyd
*14:1	98-9097	1	Seal Kit
*14:2	98-9098	1	Handle Kit
15	95-3209	1	Fitting
15:1	237-79	2	O-Ring
17	340-4	6	Fitting-Hyd
17:1	237-30	6	O-Ring
17:2	237-79	6	O-Ring
18	99-3072	1	Valve-Hyd
*18:1	98-4721	1	Seal Kit

Ref. No.	Part No.	Qty.	Description
19	98-4695	7	Tube-Spacer
20	98-4732	1	Valve-Hyd
*20:1	98-4720	1	Seal Kit
21	42-9580	10	Nut-Hex
22	98-4671	2	Handle ASM
23	98-4670	2	Handle ASM
24	3234-5	2	Screw-HHF
25	98-9090	1	Grip-Control
26	33104-030	1	Screw-HHF
27	32128-44	2	Nut-Flange
28	99-1376	1	Mount-Control
29	98-9921	1	Fitting-Straight Thread
29:1	237-145	1	O-Ring
29:2	237-79	1	O-Ring
30	98-4729	1	Lever-Valve
32	98-4724	1	Line-Hyd
33	99-3021	1	Line-Hyd
50	321-14	2	Screw-HH
51	98-9079	1	Adapter-Tee
51:1	237-30	1	O-Ring
51:2	237-79	2	O-Ring
52	99-3077	1	Valve-Hyd
*52:1	98-4721	1	Seal Kit
53	322-13	4	Screw-HH
57	3256-22	2	Washer-Flat

* Not illustrated

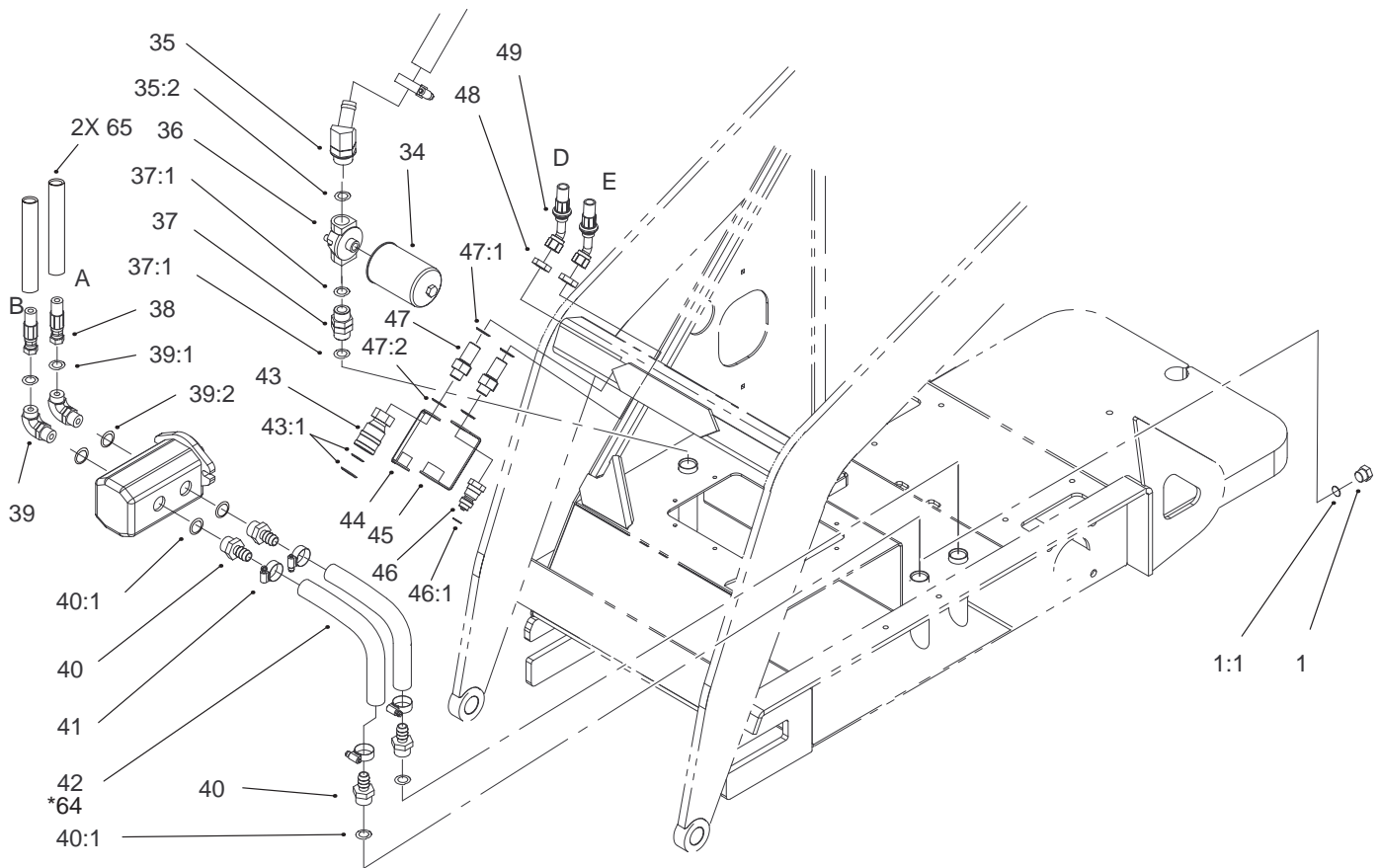

Sheet No.:61

Hydraulic Assembly (Continued)

Ref. No.	Part No.	Qty.	Description
1	353-988	1	Plug-Hex
1:1	237-79	1	O-Ring
34	54-0110	2	Filter-Oil
35	354-127	1	Fitting-Hyd 45°
35:2	237-81	1	O-Ring
36	92-5821	1	Filter Head ASM
37	98-9906	1	Fitting-Straight Thread
37:1	237-81	2	O-Ring
38	98-4747	2	Hose-Hyd
39	340-105	2	Fitting-Elbow
39:1	237-30	2	O-Ring
39:2	237-80	2	O-Ring
40	354-73	4	Fitting-Hyd
40:1	237-81	4	O-Ring
41	2412-129	4	Clamp-Hose
42	98-2713	1	Hose-Hyd
43	100-4234	1	Coupler-Flush Face
43:1	100-6119	1	Kit-Seal
44	100-8816	1	Dust Cap-Coupler
45	100-8815	1	Dust Cap-Nipple
46	100-4235	1	Nipple-Flush Face
46:1	100-6120	1	Kit-Seal
47	100-4236	2	Union-Bulkhead
47:1	237-65	2	O-Ring
47:2	237-80	2	O-Ring
48	340-74	2	Nut-Bulkhead

Ref. No.	Part No.	Qty.	Description
49	100-8817	2	Hose-Hyd
64	99-5349	2	Spring-Compression
65	100-8818	2	Sleeve-Guard, Hose
*	3290-379	8	Tie-Cable
*	3296-27	1	Nut-Lock

* Not illustrated

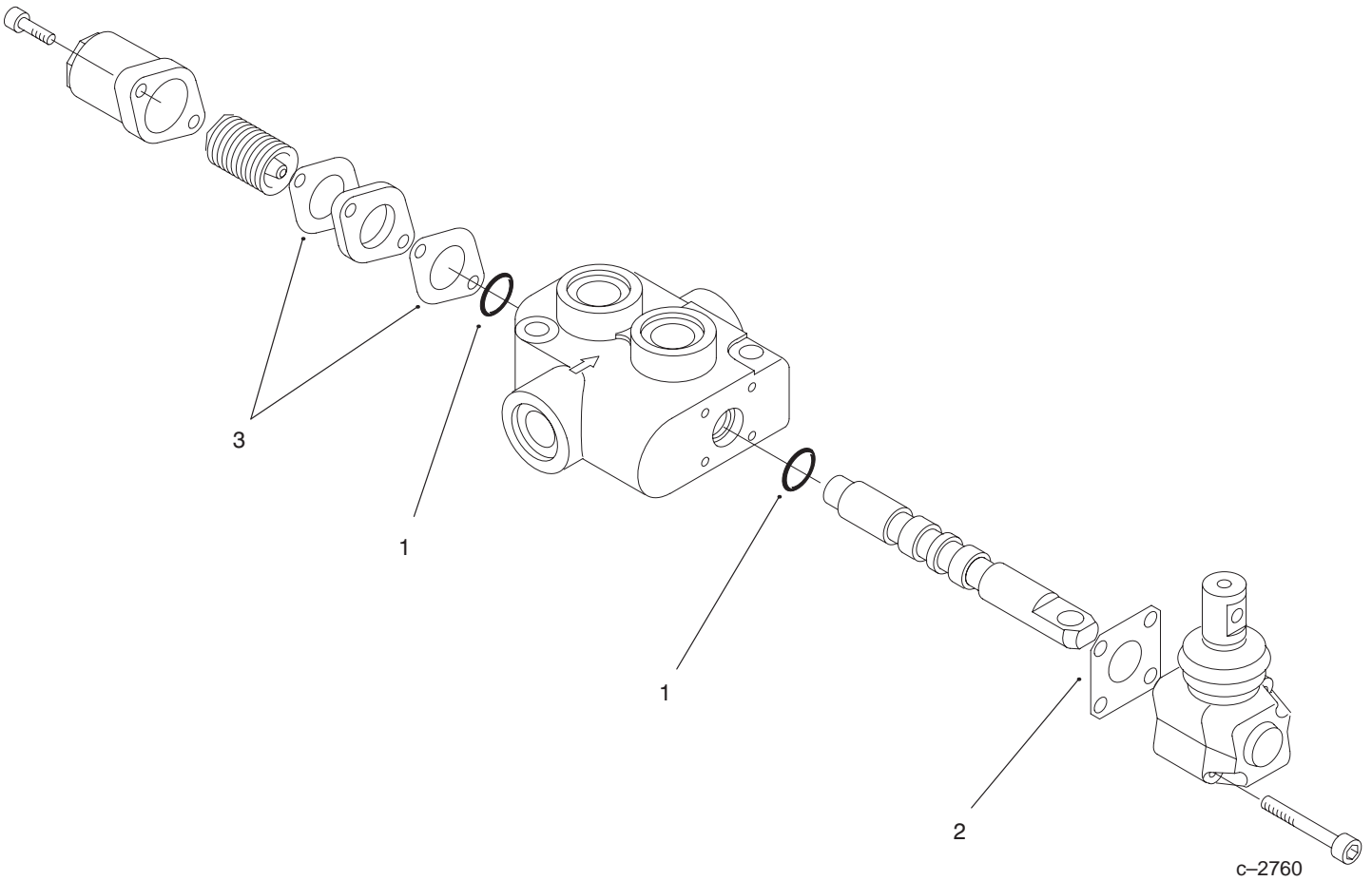

Hydraulic Valve Assembly No. 99-3072

Ref. No.	Part No.	Qty.	Description
†1		2	O-Ring
2	99-3075	1	Gasket
3	99-3074	2	Gasket
*	99-4391	1	Seal Kit (Incl. Ref.#1)

Ref. No.	Part No.	Qty.	Description

* Not illustrated
 † Not Serviced Separately

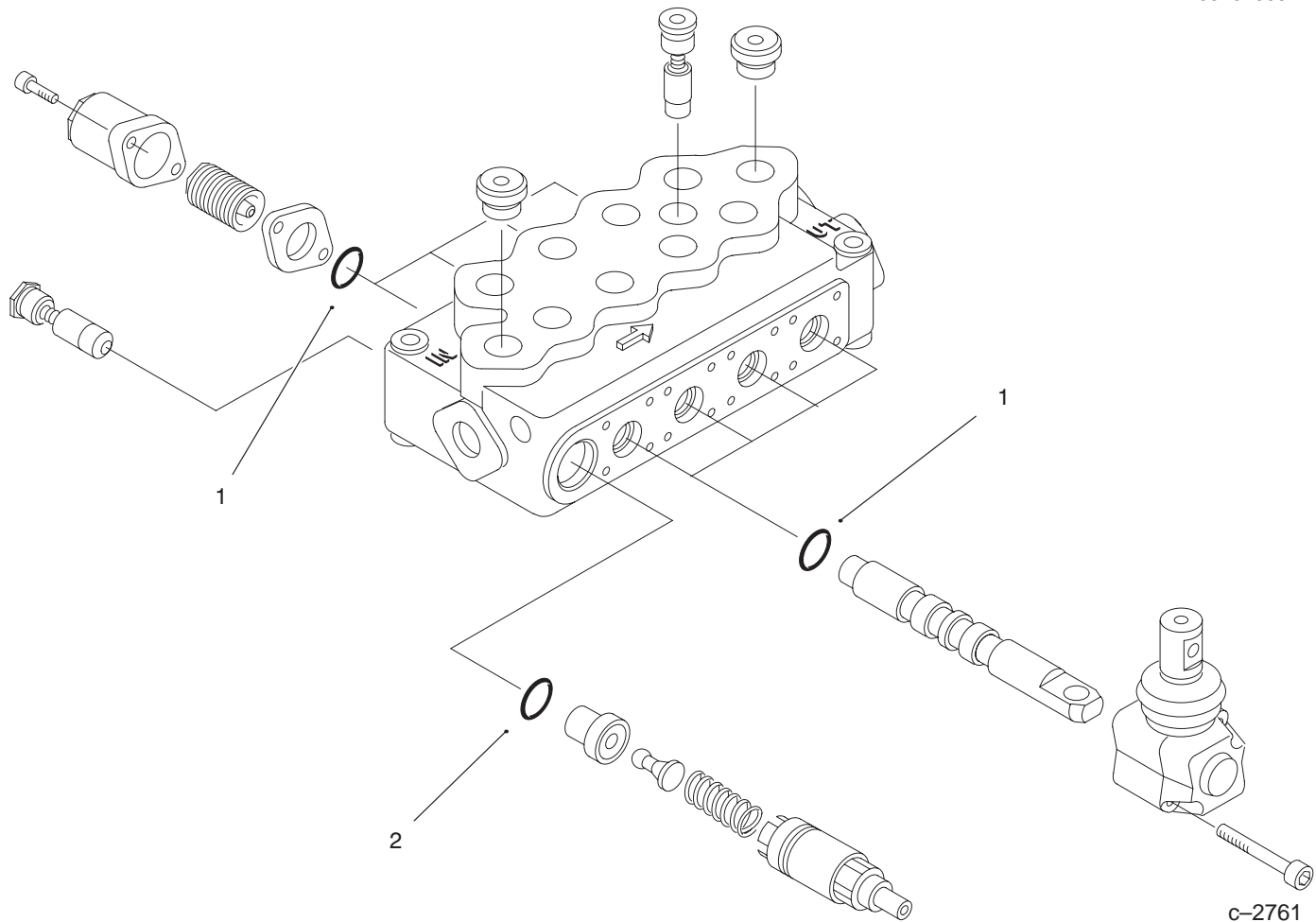

Hydraulic Valve Assembly No. 98-4732

Ref. No.	Part No.	Qty.	Description
†1	98-4720	8	O-Ring
†2		1	O-Ring
*		1	Seal Kit (Incl. Ref.# 1 & 2)

Ref. No.	Part No.	Qty.	Description

* Not illustrated

† Not Serviced Separately

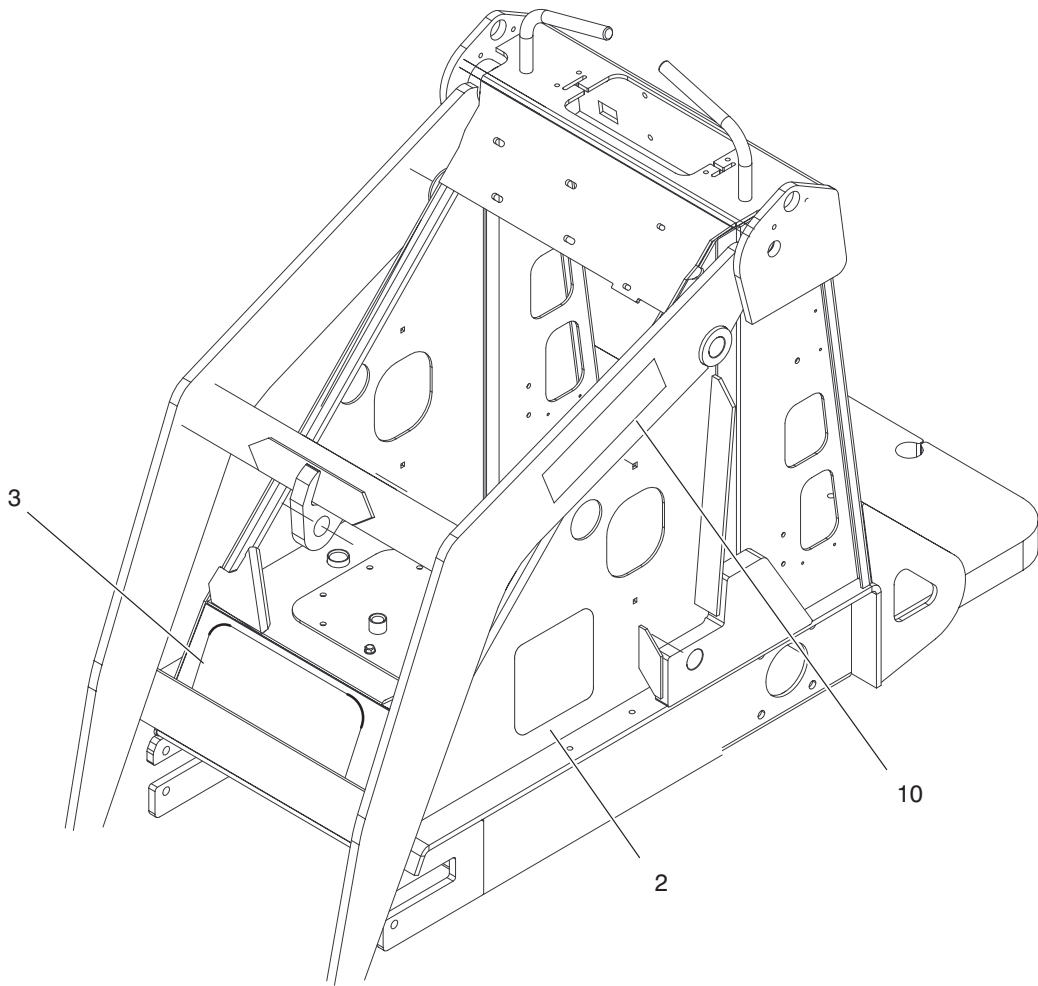

Sheet No.:8

Decal Locations

Ref. No.	Part No.	Qty.	Description
2	100-8827	2	Decal-Dingo, Side
3	100-8828	1	Decal-Front
10	98-8217	2	Decal-Dingo

Ref. No.	Part No.	Qty.	Description

* Not Illustrated

Electrical Schematic

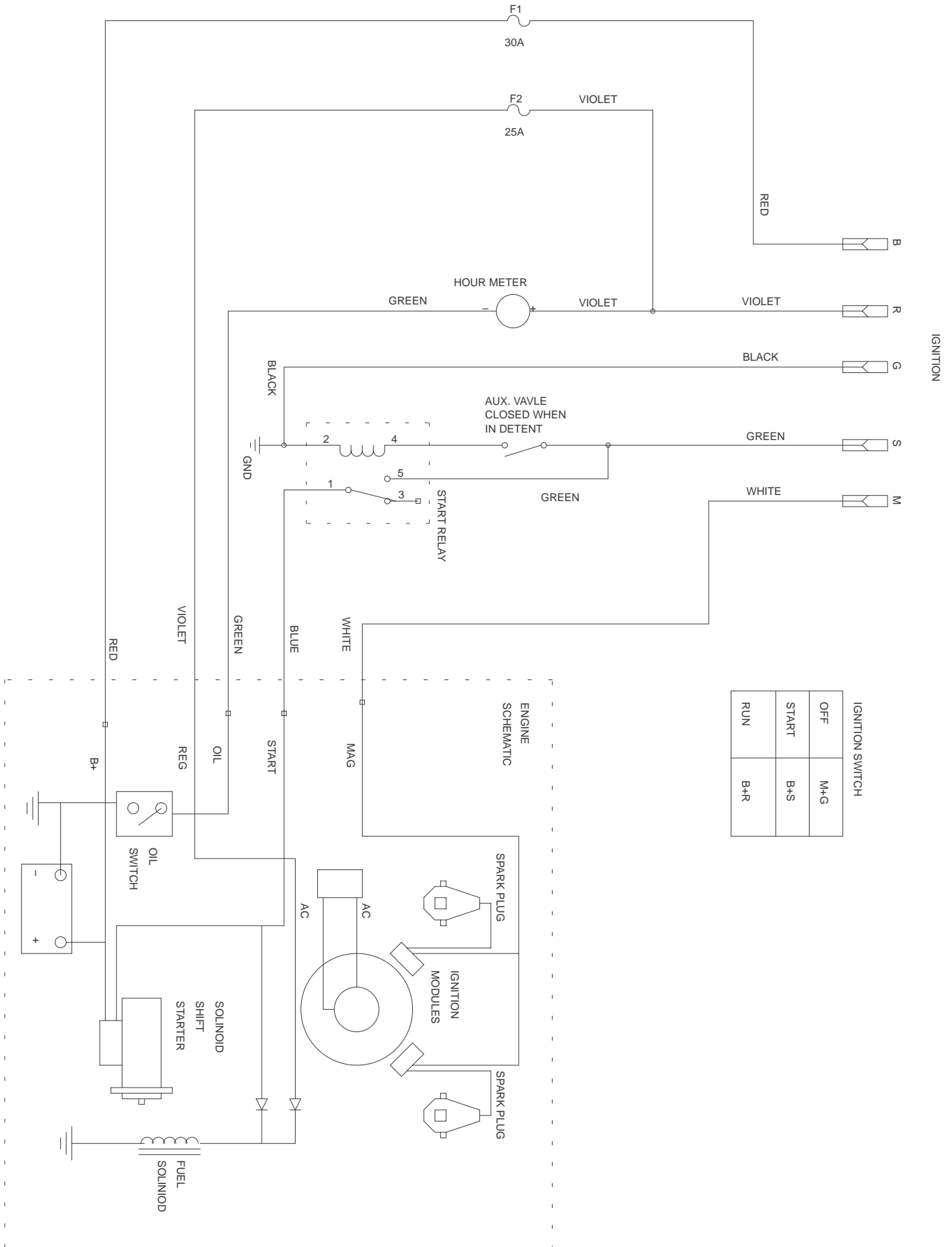

Hydraulic Schematic

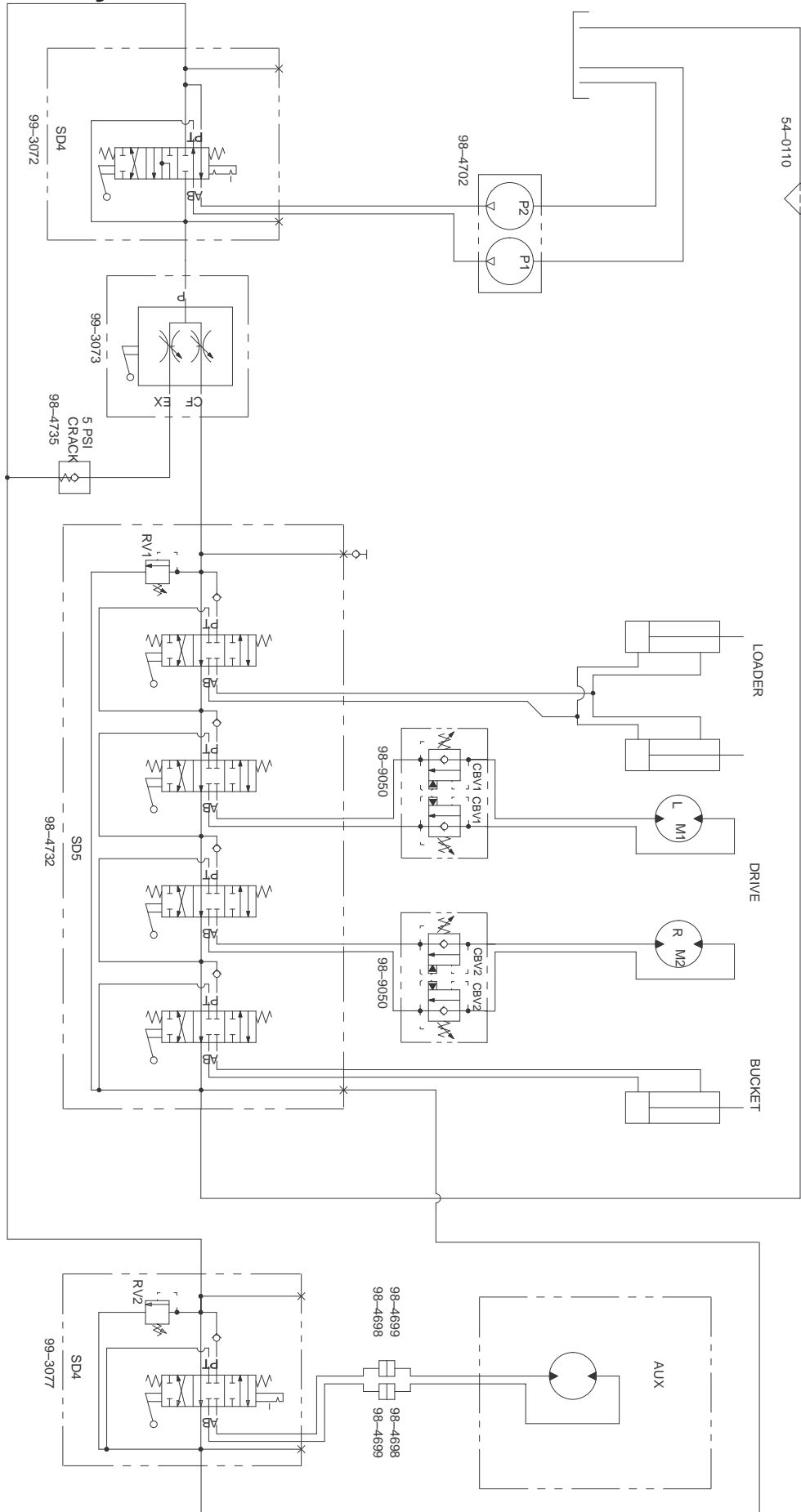

DISPLACEMENT AND PRESSURE CHART

COMPONENT	DISPLACEMENT		PRESSURE		FLOWRATE*	
	CU IN/REV	CU CM/REV	PSI	BAR	GPM	LPM
P1	0.55 CU IN	9 CC			8.4	31.8
P2	0.24 CU IN	4 CC			3.7	14.0
M1	29.1 CU IN	476 CC				
M2	29.1 CU IN	476 CC				
RV1			3000 PSI	207 BARS		
RV2			3000 PSI	207 BARS		
CBV1			1000 PSI	69 BARS		
CBV2			1000 PSI	69 BARS		

* FLOWRATE CALCULATED AT 3600 RPM AND 98% EFFICIENCY.

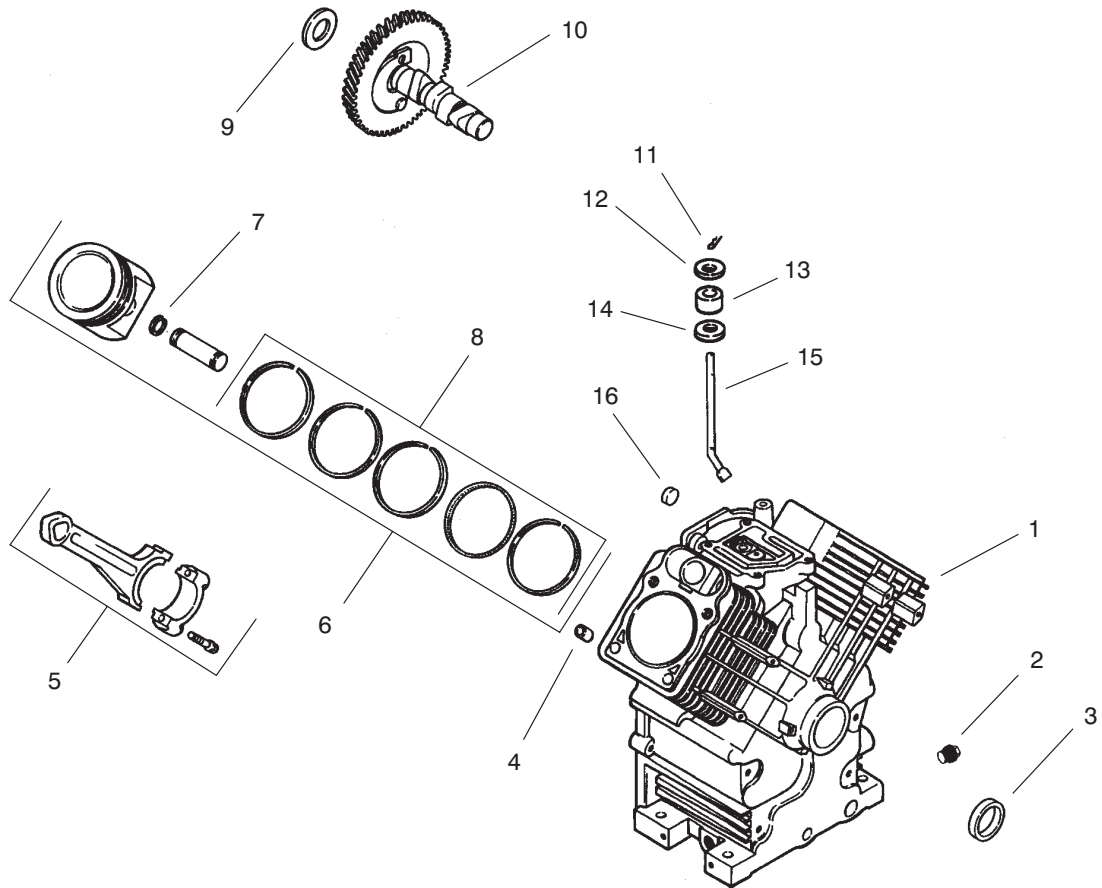

GROUP 2 – CRANKCASE

Ref. No.	Part No.	Description	No. Used
1		Cylinder Block (Use Miniblock 24 782 01)	1
2	52 139 02	Plug, drain	2
3	24 032 01	Seal, oil front	1
4	12 380 17	Pin, dowel locating	6
5	24 067 13	Connecting Rod (Std.)	2
	24 067 14	Connecting Rod (.25)	2
6	24 874 01	Piston w/Ring Set (Std.)	2
	24 874 02	Piston w/Ring Set (.25)	2
	24 874 03	Piston w/Ring Set (.50)	2
7	24 018 01	Retainer, piston pin	4
8	24 108 01	Ring Set (Std.)	2
	24 108 02	Ring Set (.25)	2
	24 108 03	Ring Set (.50)	2

Ref. No.	Part No.	Description	No. Used
9	12 422 09	Shim, camshaft – red	A/R
	12 422 13	Shim, camshaft – black	A/R
	12 422 07	Shim, camshaft – white	A/R
	12 422 08	Shim, camshaft – blue	A/R
	12 422 10	Shim, camshaft – yellow	A/R
	12 422 11	Shim, camshaft – green	A/R
	12 422 12	Shim, camshaft – gray	A/R
10	24 012 05	Camshaft	1
11	12 380 04	Pin, hitch	1
12	M-0631005	Washer, flat	1
13	12 032 01	Seal, governor cross shaft	1
14	X-25-102	Washer, plain	1
15	24 144 01	Shaft, governor cross	1
16	52 139 09	Plug, cup	1

Obtain Parts From Kohler

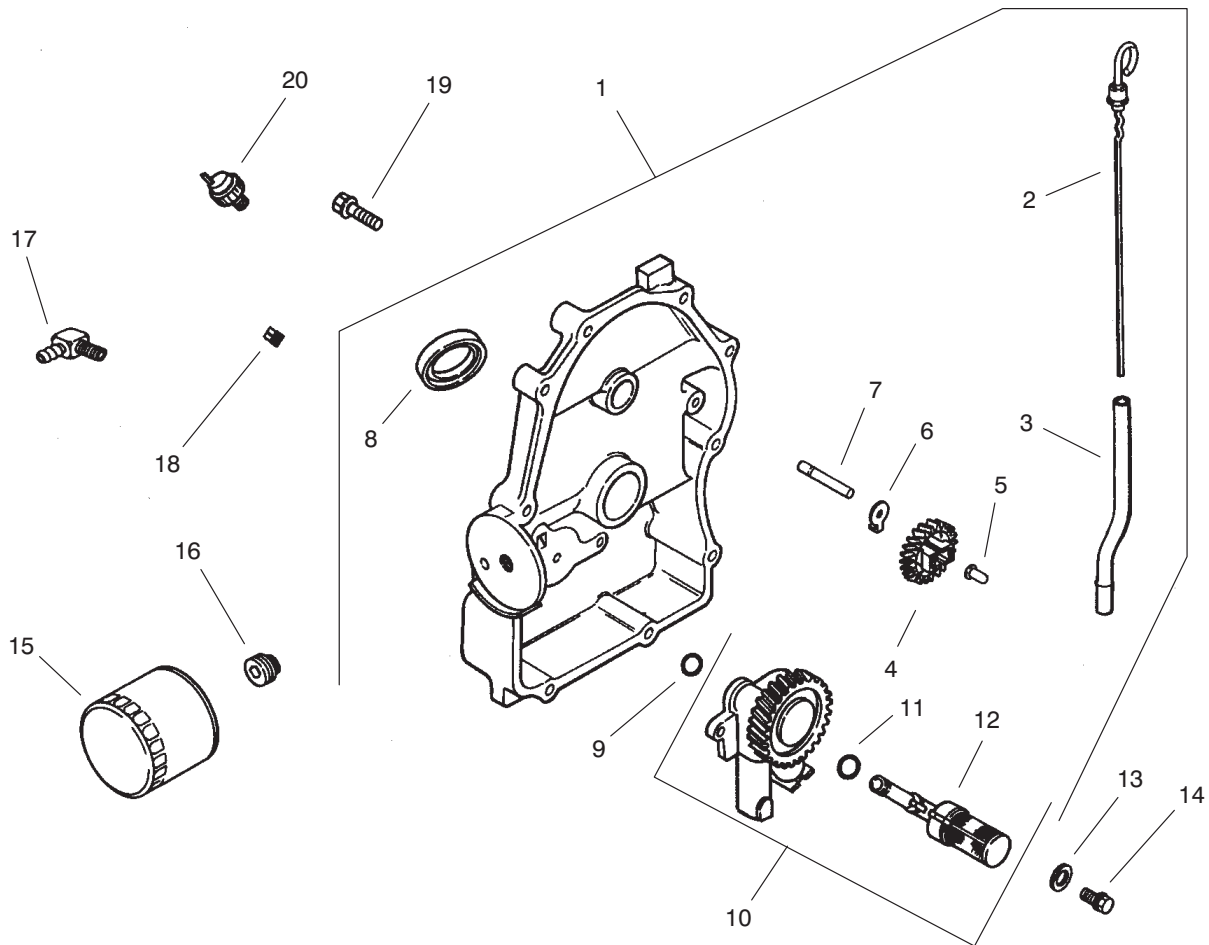

GROUP 3 – OIL PAN/LUBRICATION

Ref. No.	Part No.	Description	No. Used
1	24 009 82	Plate, closure assembly (Includes 2-12)	1
2	24 038 06	Dipstick	1
3	24 123 08	Tube, dipstick	1
4	24 043 12	Kit, governor gear (Includes 5)	1
5	12 380 01	Pin, governor regulating	1
6	52 448 02	Tab, locking	1
7	12 144 02	Shaft, governor gear	1
8	52 032 08	Seal, oil (PTO end)	1
9	24 153 08	O-Ring	1
10	24 393 10	Oil pump assembly (Includes 11,12)	1

Ref. No.	Part No.	Description	No. Used
11	24 153 01	O-Ring, oil pick-up	1
12	24 381 04	Pick-up, oil	1
13	M-0631005	Washer, plain 6 mm	2
14	M-0645025	Screw, hex. flange	2
15	52 050 02	Filter, oil	1
16	24 136 01	Nipple, oil filter	1
17	25 155 02	Connector	1
18	X-75-23	Plug, pipe	1
19	24 086 16	Screw, hex. flange	10
20	24 099 03	Switch, pressure	1

Obtain Parts From Kohler

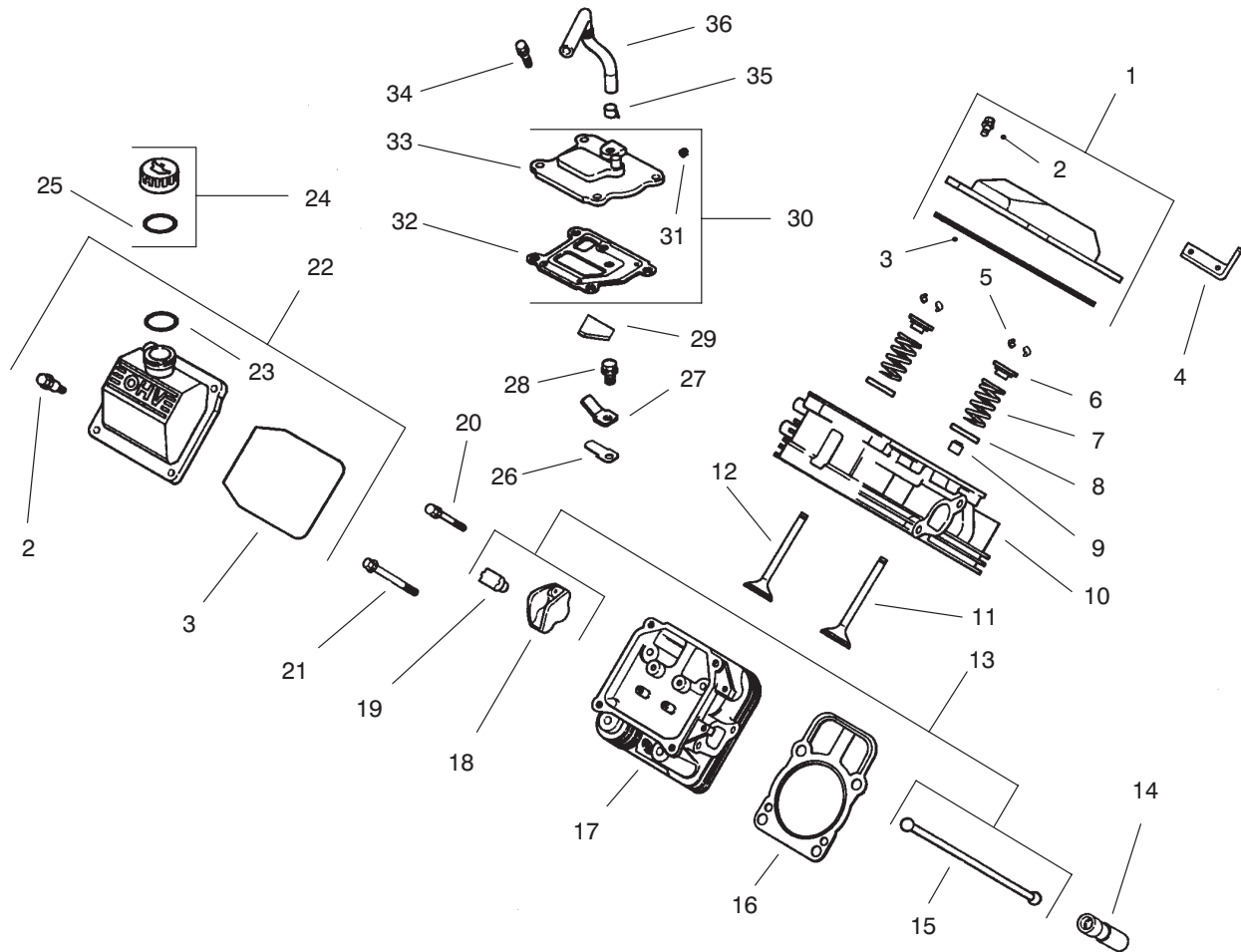

GROUP 4 – HEAD/VALVE/BREATHER

Ref. No.	Part No.	Description	No. Used	Ref. No.	Part No.	Description	No. Used
1	24 755 74	Kit, valve cover – plain (Includes 2–3)	1	18	25 186 01	Arm, rocker	4
2	24 086 32	Screw, shoulder	4	19	24 599 01	Pivot, rocker arm	4
3	24 153 16	O–Ring, valve cover	1	20	M–0640034	Screw, hex. flange	4
4	24 445 01	Strap, lifting	1	21	12 086 16	Screw, hex. flange	8
5	12 755 03	Kit, retainer	4	22	24 755 75	Kit, valve cover – oil fill (Includes 2,3,23)	1
6	12 173 01	Cap, valve spring	4	23	24 153 09	O–Ring	1
7	24 089 02	Spring, valve	4	24	24 755 46	Kit, oil fill cap (Includes 25)	1
8	235011	Retainer, spring	4	25	12 153 03	O–Ring, oil fill cap	1
9	24 032 05	Seal, valve stem	2	26	24 402 03	Reed, breather	1
10	24 318 09	Head assembly, #1 cylinder	1	27	12 018 01	Retainer, breather reed	1
11	24 017 01	Valve, intake (Std.)	2	28	M–0545010	Screw, hex. flange	1
	24 017 02	Valve, intake (.25)	2	29	24 050 01	Filter, breather	1
12	24 016 01	Valve, exhaust (Std.)	2	30	24 033 01	Kit, breather (Includes 31–33)	1
	24 016 02	Valve, exhaust (.25)	2	31	X–75–23	Plug, allen head pipe	1
13	24 755 66	Kit, valve train (Includes 15,18,19)	1	32	24 041 23	Gasket, breather	1
14	12 351 02	Lifter, valve	4	33	24 096 02	Cover, breather	1
15	24 411 05	Rod, push	4	34	M–0645020	Screw, hex. flange	4
16	24 041 08	Gasket, cylinder head	2	35	X–426–9	Clamp, breather	1
17	24 318 10	Head assembly, #2 cylinder	1	36	24 326 06	Hose, breather	1

Obtain Parts From Kohler

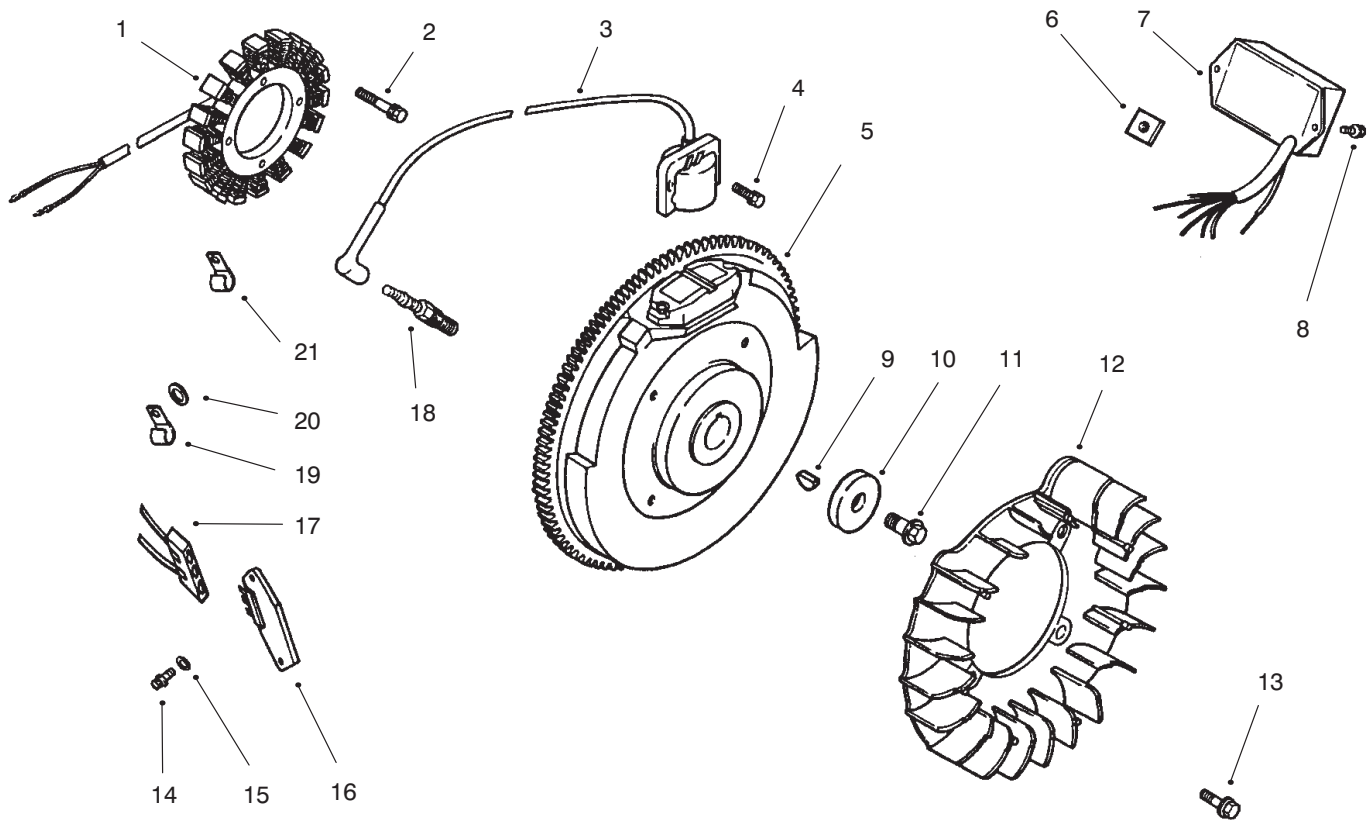

GROUP 5 – IGNITION/ELECTRICAL

Ref. No.	Part No.	Description	No. Used
1	54 755 09	Kit, 15 amp stator (Incl. 24 126 71 bracket)	1
2	M-0548025	Screw, hex. cap	2
3	24 584 11	Module, ignition	2
4	M-0561025	Screw, hex. socket hd	4
5	24 025 02	Flywheel	1
6	24 100 02	Nut, plastic	2
7	24 584 09	Module, speed advance	1
8	24 086 41	Screw	2
9	X-42-15	Key	1
10	12 468 03	Washer, plain	1
11	12 086 14	Screw, hex. flange	1
12	24 157 03	Fan	1
13	25 086 47	Bolt, shoulder	4
14	24 086 18	Screw, phillips hd.	2
15	X-25-92	Washer, plain	2

Ref. No.	Part No.	Description	No. Used
16	25 403 03	Rectifier-regulator	1
17	236602	Connector	1
18	12 132 02	Spark Plug	2
19	47 154 01	Clip, cable	1
20	X-25-63	Washer, plain	1
21	48 154 02	Clip, cable	1
		Not Illustrated	
	25 518 28	Lead, black, (4" - 18 gauge - insulated grip barrel eyelet terminals)	1
	24 176 42	Harness, wiring	1
	24 126 71	Bracket, stator wire	1
	X-22-11	Washer, lock	1
	X-25-63	Washer, plain	1

Obtain Parts From Kohler

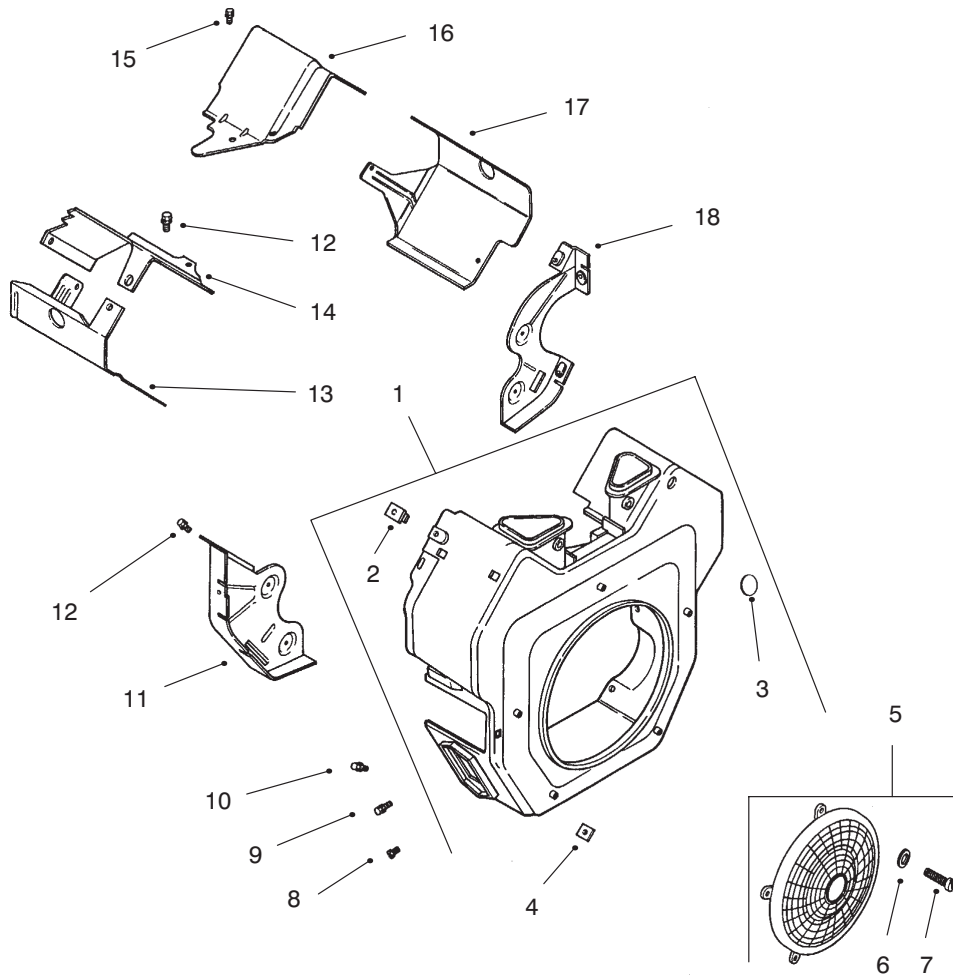

GROUP 6 – BLOWER HOUSING & BAFFLES

Ref. No.	Part No.	Description	No. Used
1	24 027 40	Housing, blower (Includes 2-5)	1
2	24 100 02	Nut, plastic	2
3	25 139 16	Button plug	1
4	24 100 01	Nut, plastic	2
5	24 755 81	Kit, Fixed Gurard (Includes 6&7)	1
6	24 468 10	Washer, plain	5
7	24 086 35	Screw, panhead	5
8	M-0551016	Screw, hex. flange	1
9	M-0545016	Screw, hex. flange	5
10	M-0545020	Screw, hex. flange	2

Ref. No.	Part No.	Description	No. Used
11	24 146 02	Plate, backing – #2 side	1
12	M-0645016	Screw, hex. flange	6
13	24 063 20	Baffle, cyl. barrel – #2 side	1
14	24 063 17	Baffle, valley – #2 side	1
15	M-0545010	Screw, hex. flange	2
16	24 063 24	Baffle, valley – #1 side	1
17	24 063 08	Baffle, cyl. barrel – #1 side	1
18	24 146 08	Plate, backing – #1 side	1
		Not Illustrated	
	24 113 62	Decal, HP	1
	25 113 21	Decal, Pro	1

Obtain Parts From Kohler

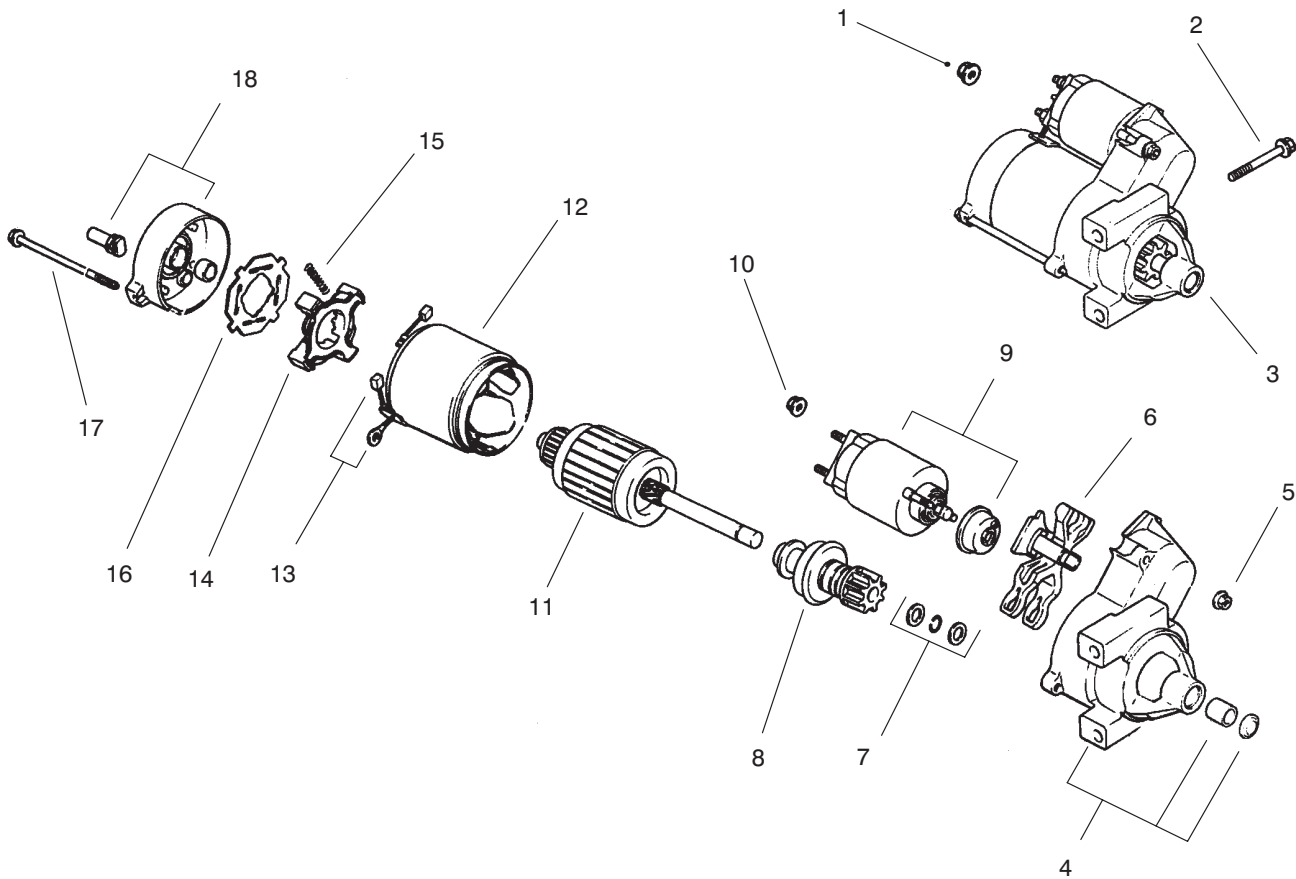

GROUP 7 – STARTING SYSTEM

Ref. No.	Part No.	Description	No. Used
1	M-0841080	Nut, hex flange	1
2	M-0839080	Screw, hex. flange	2
3	24 098 01	Starter, solenoid shift assembly (Incl. 4-18)	1
4	24 081 04	Drive, end cap	1
5	52 100 10	Nut, starter	2
6	12 090 10	Lever, starter drive	1
7	24 755 84	Kit, starter repair	1
8	12 239 01	Drive, pinion	1
9	52 435 02	Solenoid	1

Ref. No.	Part No.	Description	No. Used
10	52 100 09	Nut, starter	1
11	12 170 04	Armature, starter	1
12	12 471 01	Frame	1
13	52 221 01	Kit, brush & spring (Includes 15)	1
14	52 323 03	Holder, brush	1
15	52 089 09	Spring, brush	4
16	52 168 01	Insulator	1
17	52 211 05	Bolt, thru	2
18	24 301 01	Commutator, end cap	1

Obtain Parts From Kohler

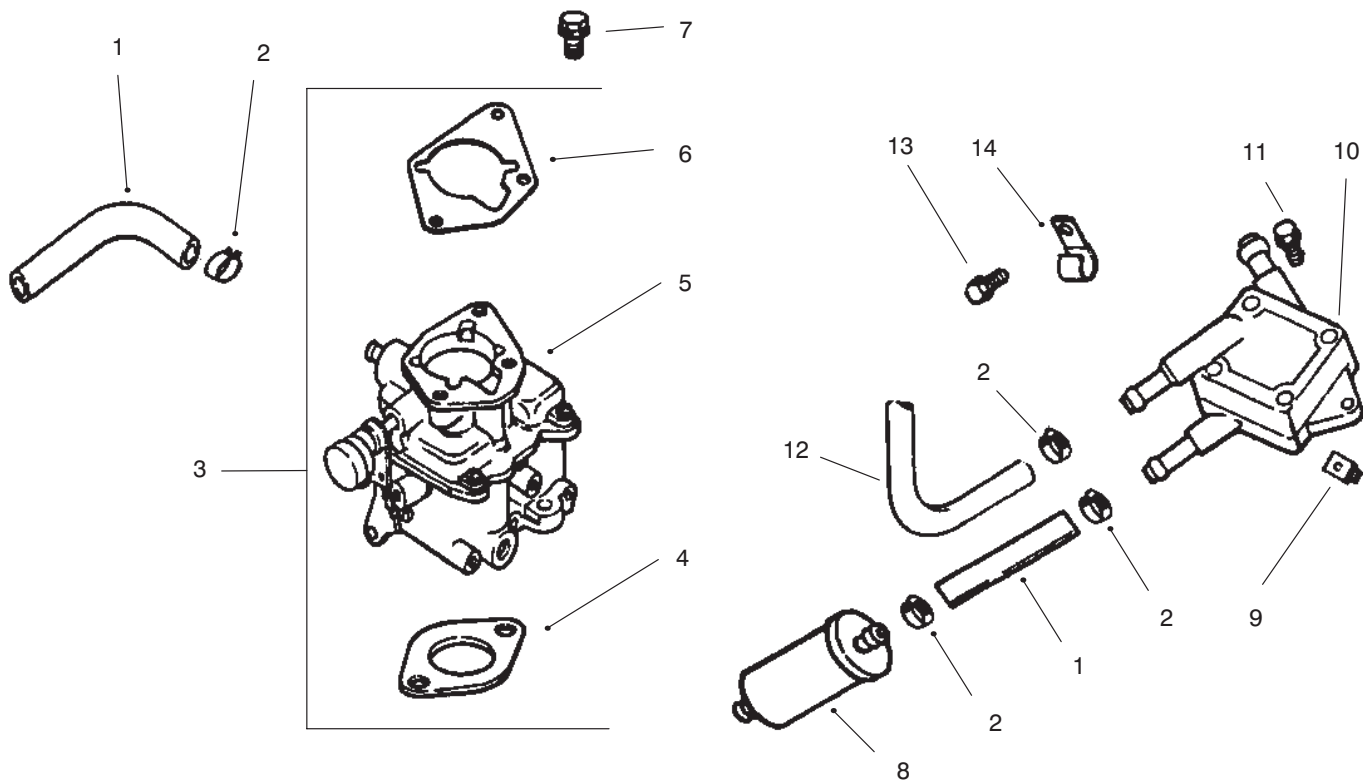

GROUP 8 – FUEL SYSTEM

Ref. No.	Part No.	Description	No. Used
1	25 353 10	Line, fuel – 9"	2
2	X-426-9	Clamp, hose	6
3	24 853 43	Kit, carburetor w/gasket (Includes 4-6)	1
4	24 041 06	Gasket, air cleaner base	1
5	24 053 43	Carburetor assembly (For information only not available separately)	1
6	24 041 17	Gasket, carburetor	1

Ref. No.	Part No.	Description	No. Used
7	M-0651030	Screw, hex. flange	2
8	24 050 02	Filter, fuel	1
9	24 100 01	Nut, plastic	2
10	24 393 04	Pump, fuel – pulse	1
11	24 086 12	Screw, hex. cap	2
12	24 353 04	Line, fuel 17"	1
13	M-0650012	Screw, hex. flange	1
14	47 154 01	Clip, cable	1

Obtain Parts From Kohler

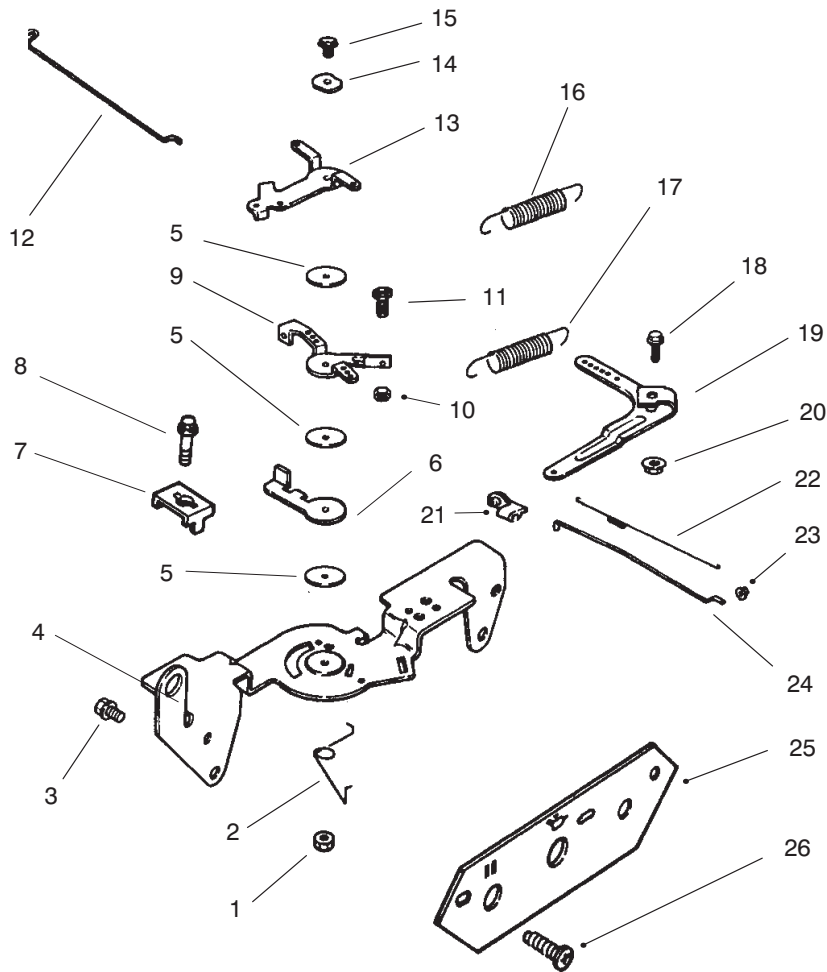

GROUP 9 – ENGINE CONTROLS

Ref. No.	Part No.	Description	No. Used
1	M-0547050	Nut, hex. lock	1
2	24 089 03	Spring, choke return	1
3	M-0645016	Screw, hex. flange	4
4	24 126 56	Bracket, control	1
5	24 468 01	Washer, plain	3
6	24 090 07	Lever, throttle actuator	1
7	12 237 01	Clamp, cable	2
8	M-0545016	Screw, hex. flange	2
9	24 090 03	Lever, throttle control	1
10	M-0446030	Nut, hex	1
11	M-0401030	Screw, hex. cap	1
12	24 079 02	Linkage, choke	1
13	24 090 05	Lever, choke	1
14	41 468 03	Washer, spring	1

Ref. No.	Part No.	Description	No. Used
15	M-0545020	Screw, hex. flange	1
16	24 089 38	Spring, throttle limiter	1
17	24 089 15	Spring, governor	1
18	SM-0642025	Screw, hex. flange	1
19	24 090 14	Lever, governor	1
20	M-0641060	Nut, hex. flange	1
21	25 158 11	Bushing, linkage retaining	1
22	24 089 01	Spring, linkage	1
23	25 158 08	Bushing, linkage retaining	1
24	24 079 01	Linkage, throttle	1
25	24 378 01	Panel, control	1
26	24 086 06	Screw, phillips	1

Obtain Parts From Kohler

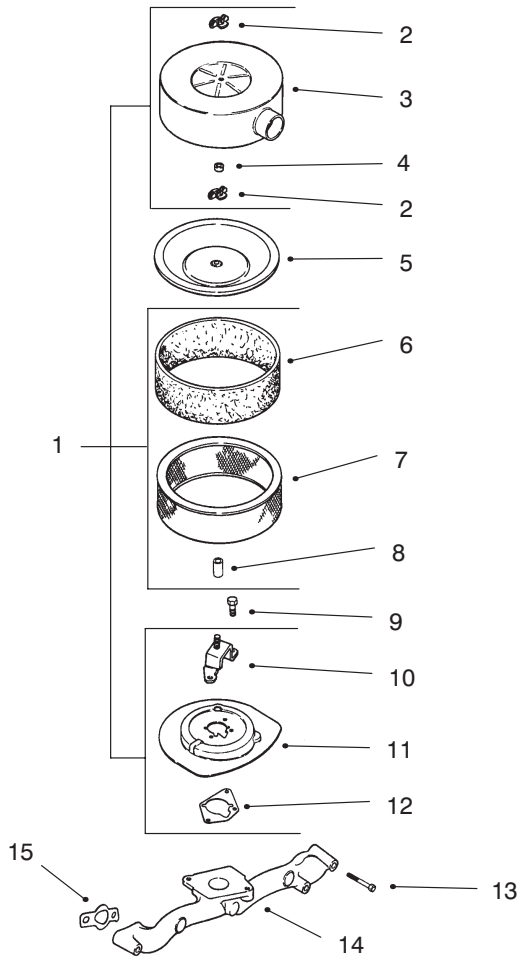

GROUP 10 – AIR INTAKE/FILTRATION

Ref. No.	Part No.	Description	No. Used	Ref. No.	Part No.	Description	No. Used
1	24 755 21	Kit, air cleaner cover (Includes 2-4, 6-8, 10-12 and decal 24 113 31)	1	10	24 126 22	Bracket, air cleaner base	1
2	12 100 01	Wing Nut	1	11	24 094 05	Base, air cleaner	1
3	24 096 52	Cover, air cleaner	1	12	24 041 06	Gasket, air cleaner base	1
4	41 032 02	Seal	1	13	M-0651055	Screw, hex. flange	4
5	24 096 01	Cover, inner air cleaner	1	14	24 164 14	Manifold, intake	1
6	24 083 02	Precleaner, element	1	15	24 041 01	Gasket, intake manifold	2
7	47 083 03	Element, air cleaner	1			Not Illustrated	
8	230046	Seal	1		24 113 31	Decal, Air Cleaner	1
9	M-0639016	Screw, hex. flange	3		24 048 02	Precleaner Assembly	1

Obtain Parts From Kohler

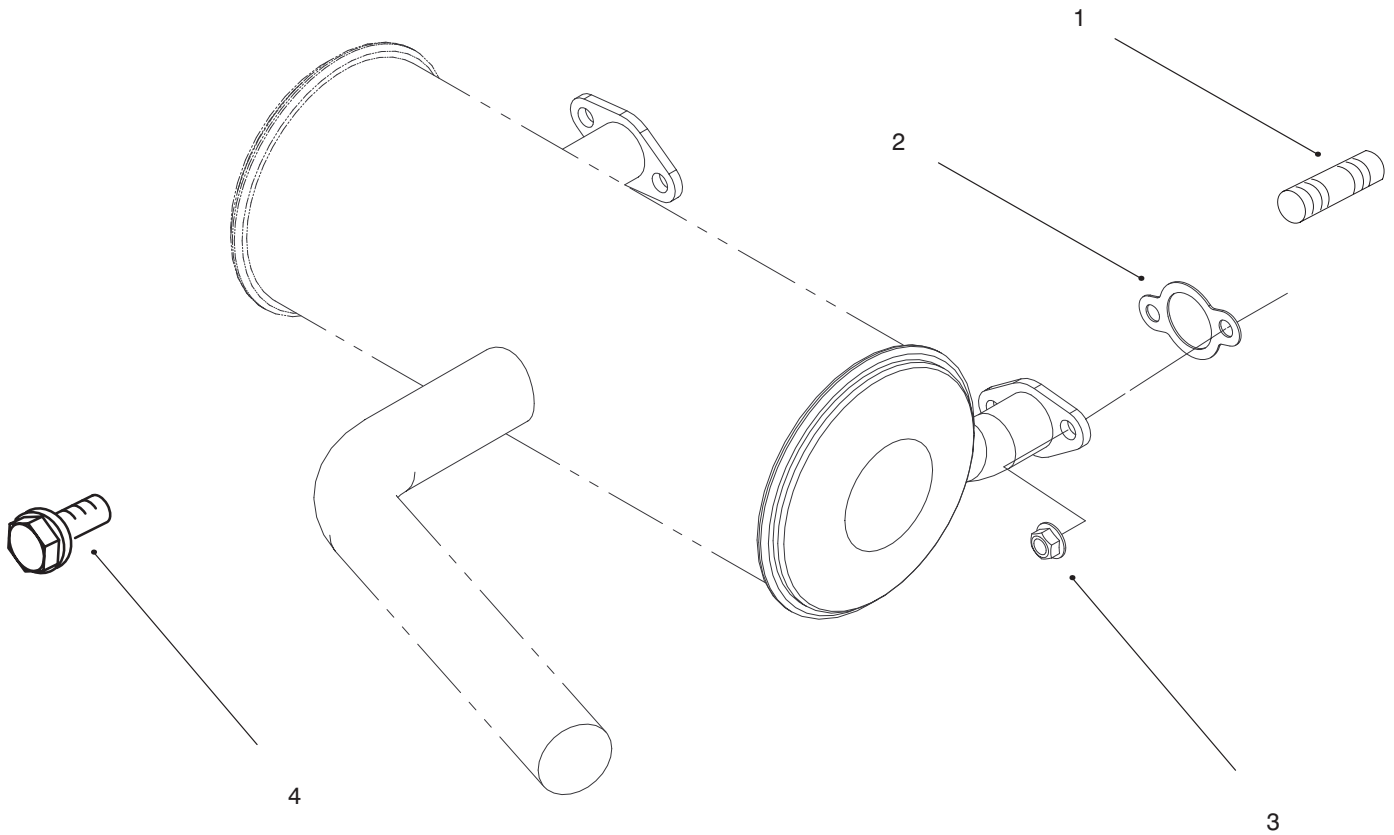

GROUP 11 – EXHAUST

Ref. No.	Part No.	Description	No. Used
1	25 072 04	Stud	4
2	93-0350	Gasket, exhaust	2
3	M-0841080	Nut, hex flange	4

Ref. No.	Part No.	Description	No. Used
4	M-0839020	Screw, hex. flange	2
*	24 755 03	Gasket Set	1

Obtain Parts From Kohler

* Not Illustrated

