



Introduction

The GeoLink® spray system kit is an attachment for a turf spray application vehicle and is intended to be used by professional, hired operators in commercial applications. It is designed primarily for spraying on well-maintained lawns in parks, golf courses, sports fields, and on commercial grounds.

You may contact Toro directly at www.Toro.com for product safety and operation training materials, accessory information, help finding a dealer, or to register your product.

Contents

Introduction	1	20 Installing the Sprayer Monitor.....	57
Safety	2	21 Installing the Wire Harnesses for the	
Setup	3	Navigation Components.....	58
1 Preparing to Install the Kit	6	22 Connecting the Wire Harness for the	
2 Disconnecting the Rear Wire Harness from		Optional Pivoting Hose-Reel Kit	65
the Optional Attachments.....	7	23 Connecting the Compressor Wire	
3 Removing the Pressure Control		Harness for the Optional Foam-Marker	
Switch—Optional Pivoting Hose-Reel		Kit.....	65
Kit.....	8	24 Connecting the Optional Tank-Rinse	
4 Removing the Undercarriage Shroud	9	Kit.....	66
5 Removing the Engine-Control Module and		25 Completing the Installation of the GeoLink	
Mounting Bracket (Machine Models with a		Spray System-Finishing Kit	66
Gasoline Engine)	11	26 Powering the GeoLink Components.....	69
6 Disconnecting the Pressure-Sense Tube		27 Verifying the Software Version	69
for the Dash Gauge	12	28 Selecting the Units of Measure.....	70
7 Removing the Rear Wire Harness for the		29 Creating a Field	70
Machine	12	30 Creating a New Application Rate	
8 Removing the Rate-Control Switch	17	Product	70
9 Removing the Boom-Section Valves	17	31 Creating a Spray Job	70
10 Installing the Flow Meter and Pressure		32 Checking the Spray System	71
Transducer.....	26	33 Balancing the Agitation Bypass	
11 Installing the Valve Mount and Sprayer		Valve	73
Valves	28	34 Performing a Flow Meter Calibration	74
12 Removing the Sprayer-Nozzle Hoses for		35 Verifying the Cellular Status	74
the 3-Section System	31	36 Performing a Compass Calibration.....	75
13 Installing the Sprayer-Nozzle Hoses	33	37 Performing a Compass Calibration.....	75
14 Assembling the Rear Wiring Harness to			
the Machine	40		
15 Installing the Engine-Control Module and			
Mounting Bracket (Machine Models with a			
Gasoline Engine)	44		
16 Installing the Undercarriage Shroud	45		
17 Connecting the Rear Wire Harness	46		
18 Connecting the Pressure-Sense Tube for			
the Dash Gauge	54		
19 Installing the Navigation Receiver	55		



Safety

⚠ WARNING

Chemical substances used in the spray system may be hazardous and toxic to you, bystanders, animals, plants, soils, or other property.

- Carefully read and follow the chemical warning labels and material safety data sheets (MSDS) for all chemicals used and protect yourself according to the chemical manufacturer's recommendations. For example, use appropriate personal protective equipment (PPE), including face and eye protection, gloves, or other equipment to guard against personal contact with a chemical.
- There may be more than 1 chemical used and information on each chemical should be assessed.
- Refuse to operate or work on the sprayer if this information is not available.
- Before working on a spray system, ensure that the system has been triple rinsed and neutralized according to the recommendations of the chemical manufacturer(s) and that all the valves have been cycled 3 times.
- Verify that there is an adequate supply of clean water and soap nearby, and immediately wash off any chemicals that contact you.

Installation

Loose Parts

Use the chart below to verify that all parts have been shipped.

Procedure	Description	Qty.	Use
1	No parts required	–	Prepare to install the kit.
2	No parts required	–	Disconnect the rear wire harness from the optional attachment.
3	Switch plug (pivoting hose-reel kit—Toro Part No. 99-7420)	1	Disconnect the optional pivoting hose-reel kit.
4	No parts required	–	Remove the undercarriage shroud.
5	No parts required	–	Remove the engine-control module and mounting bracket (machine models with gasoline engines).
6	No parts required	–	Disconnecting the pressure-sense tube for the dash gauge.
7	Rear wire harness	1	Remove the rear wire harness for the machine.
8	Cable tie Switch plug	1 1	Remove the rate-control switch.
9	Fitting cap Cap (quick coupler) Retainer	1 3 3	Remove the boom-section valves.
10	Flow meter (for 2016 machines without the ExcelsaRate sprayer system only)—not included in this kit; order Toro Part No. 106-1038. Flange clamp 51 mm (2 inches) Gasket (1-5/16 inch outside diameter) Barbed-flange fitting (1 inch) Hose (1 x 7-1/4 inches) Hose clamp Pressure transducer (for 2016 machines without the ExcelsaRate sprayer system only)—not included in this kit; order Toro Part No. 130-8202. Fitting cap—ported (for 2016 machines without the ExcelsaRate sprayer system only)—not included in this kit; order Toro Part No. 127-1185. Manifold Hose (1 x 8-1/2 inches) R-clamp	1 1 1 1 3 1 1 1 1 1	Install the flow meter and pressure transducer.

Procedure	Description	Qty.	Use
11	Valve mount and sprayer-valve assembly	1	Install the valve mount and valves.
	Bolt (4 x 10 mm)	4	
	Sprayer controller	1	
	Flange locknut (4 mm)	4	
	Flange-head bolts (5/16 x 3/4 inch)	8	
	Flange locknuts (5/16 inch)	8	
	Hose clamp	1	
	Flange head bolt (1/4 x 3/4 inch)	2	
	Flange locknut (1/4 inch)	2	
12	No parts required	–	Remove the sprayer nozzle hoses.
13	Supply hose 279 cm (110 inches)	2	Install the sprayer nozzle hoses.
	Supply hose 234 cm (92 inches)	2	
	Supply hose 188 cm (74 inches)	4	
	Supply hose 81 cm (32 inches)	2	
	R-clamp	2	
	Double R-clamp	2	
	Single R-clamp	2	
14	Rear wire harness	1	Assemble the rear wiring harness to the machine.
	Cable tie	3	
15	No parts required	–	Install the engine-control module and mounting bracket (machine models with gasoline engines).
16	No parts required	–	Install the undercarriage shroud.
17	Cable tie	3	Connect the rear wire harness.
18	No parts required	–	Connect the pressure-sense tube for the dash gauge.
19	Navigation receiver—GeoLink precision-spray-system kit (Model 41623—North America or 41630—International and North America)	1	Install the navigation receiver.
	Receiver mount	1	
	U-bolt	2	
	RTK-antenna bracket (use with the optional CDMA RTK correction modem kit or GSM RTK correction modem kit)	1	
	Flange locknut (3/8 inch)	4	
	Hex-head bolt (5 x 16 mm)	3	
	Washer (5 mm)	3	
	Cellular antenna (optional CDMA RTK correction modem kit or GSM RTK correction modem kit)	1	
	Coaxial cable (optional CDMA RTK correction modem kit or GSM RTK correction modem kit)	1	

Procedure	Description	Qty.	Use
20	Sprayer Monitor—GeoLink precision-spray-system kit (Model 41623 for North America machines only or Model 41630 for both North America and international machines)	1	Install the sprayer monitor.
	Ball mount—GeoLink precision-spray-system kit (Model 41623 for North America machines only or Model 41630 for both North America and international machines)	1	
	Monitor arm	1	
	Reinforcement plate	1	
	Flange-head bolts (1/4 x 1-1/2 inches)	4	
	Flange locknut (1/4 inch)	4	
21	Data Harness (navigation system)—GeoLink precision-spray-system kit (Model 41623—North America or 41630—International and North America)	1	Install the wire harnesses for the navigation components.
	Electrical Harness (navigation system)—GeoLink precision-spray-system kit (Model 41623—North America or 41630—International and North America)	1	
	Cable tie	6	
22	No parts required	–	Connect the wire harness for the optional pivoting hose-reel kit.
23	No parts required	–	Connect the optional foam-marker kit.
24	No parts required	–	Connect the optional tank-rinse kit.
25	No parts required	–	Complete the installation of the GeoLink spray system-finishing kit.
26	No parts required	–	Power the GeoLink components.
27	No parts required	–	Verify the software version.
28	No parts required	–	Select the units of measure.
29	No parts required	–	Create a field.
30	No parts required	–	Create a new product.
31	No parts required	–	Create a generic spray job.
32	No parts required	–	Check the spray system.
33	No parts required	–	Balance the agitation bypass valve.

Procedure	Description	Qty.	Use
34	No parts required	–	Perform a flow meter calibration.
35	No parts required	–	Verify the cellular status.
36	No parts required	–	Perform a compass calibration.
37	No parts required	–	Perform a compass calibration.

1

Preparing to Install the Kit

No Parts Required

Preparing the Sprayer Tank and Optional Rinse Tank

1. Park the machine on a level surface.
2. Engage the parking brake; refer to the *Operator's Manual*.
3. Extend the left and right boom sections to the horizontal position.
4. Shut off the engine; refer to the *Operator's Manual*.
5. Clean the sprayer; refer to Cleaning the Sprayer in the *Operator's Manual* for the machine.

Important: You must completely empty the sprayer tank before installing the GeoLink Spray System Finishing Kit.

6. For machines with the optional tank-rinse kit, perform the following:
 - A. Pump the water from the rinse tank into the sprayer tank; refer to Operating the Rinse Kit in the *Installation Instructions* for the Tank-Rinse Kit.
 - B. Drain the water from the sprayer tank; refer to Cleaning the Sprayer in the *Operator's Manual* for the machine.
7. Remove the key from the key switch; refer to the *Operator's Manual*.

Disconnecting the Battery

1. Remove the battery cover and disconnect the negative (black—ground) cable from the battery post (Figure 1 and Figure 2).

▲ WARNING

Electrical sparks can cause the battery gasses to explode, resulting in personal injury.

Incorrect battery cable routing could damage the sprayer and cables, causing sparks.

- Always disconnect the negative (black) battery cable before disconnecting the positive (red) cable.
- Always connect the positive (red) battery cable before connecting the negative (black) cable.

Battery terminals or metal tools could short against metal sprayer components, causing sparks.

- When removing or installing the battery, do not allow the battery terminals to touch any metal parts of the sprayer.
- Do not allow metal tools to short between the battery terminals and metal parts of the sprayer.
- Always keep the battery strap in place to protect and secure the battery.

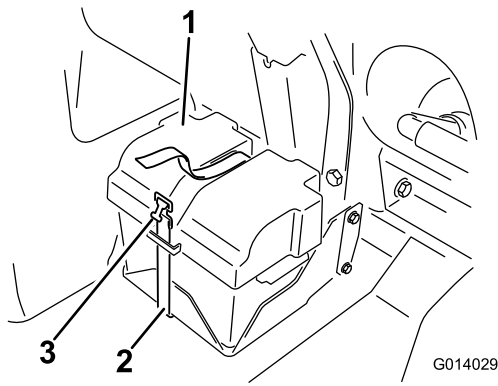

Figure 1

- 1. Battery cover
- 2. Strap
- 3. Buckle

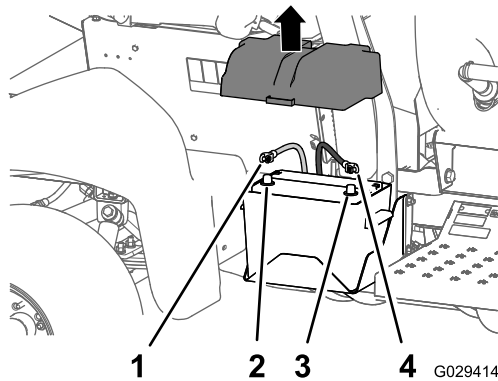

Figure 2

- 1. Positive battery cable
- 2. Positive battery post
- 3. Negative battery post
- 4. Negative battery cable

2. Disconnect the positive (red) cable from the battery post (Figure 2).
3. Tilt both seats forward and secure them by moving the prop rods into the detents at the end of the slots at the center-console base.
4. Allow the engine to cool completely.

2

Disconnecting the Rear Wire Harness from the Optional Attachments

No Parts Required

Disconnecting the Pivoting Hose-Reel Kit

1. At the back of the machine, locate the wire harness for the electric-hose-reel kit at the back of the sprayer tank (A in Figure 3).

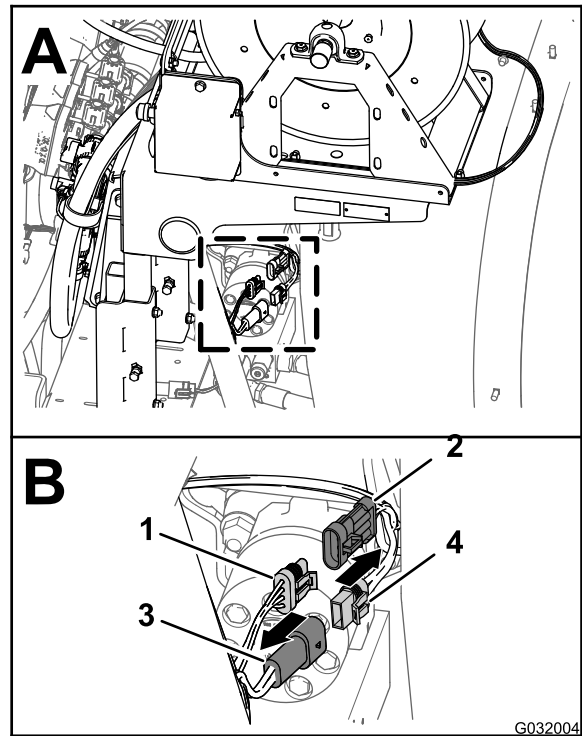

Figure 3

- 1. 3-socket connector (rear-main harness)
- 2. 2-pin connector (rear-main harness)
- 3. 3-pin connector (harness—electric-hose reel)
- 4. 2-socket connector (harness—electric-hose reel)

2. Disconnect the 2-socket connector of the harness for the electric-hose reel from the 2-pin connector of the rear-main harness (B in Figure 3).
3. Disconnect the 3-pin connector of the harness for the electric-hose reel from the 3-pin socket of the rear-main harness (B in Figure 3).

Disconnecting the Compressor for the Foam-Marker Kit

1. At the back of the foam-marker tank, locate the wire harness at the compressor (Figure 4).

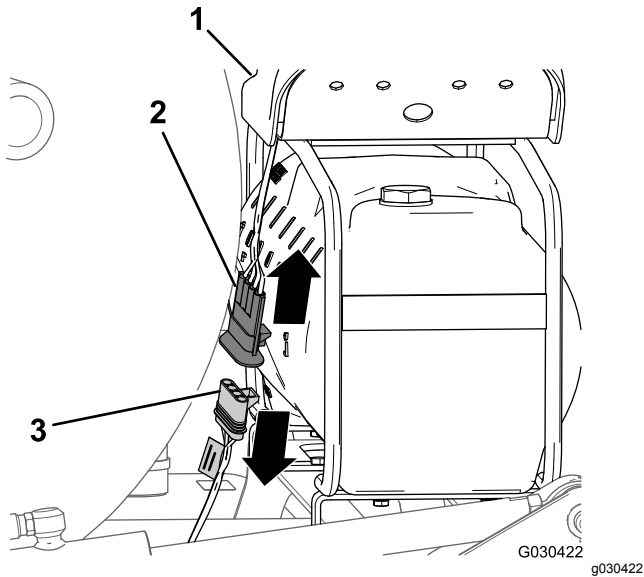

Figure 4

1. Compressor
2. 4-pin connector (wire harness for the compressor)
3. 4-socket connector (wire harness for the finishing kit)

2. Disconnect the 4-pin connector of the compressor harness from the 4-socket connector of the rear wire harness of the machine (Figure 4).

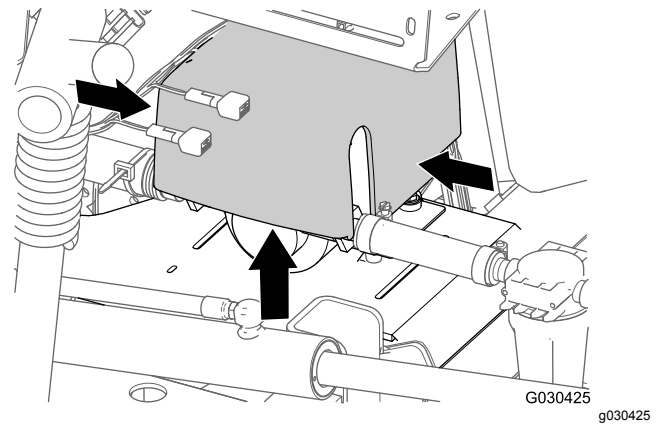

Figure 5

2. Disconnect the 6-pin connector of the rinse-pump harness from the 6-socket connector of the rear, main harness (Figure 6).

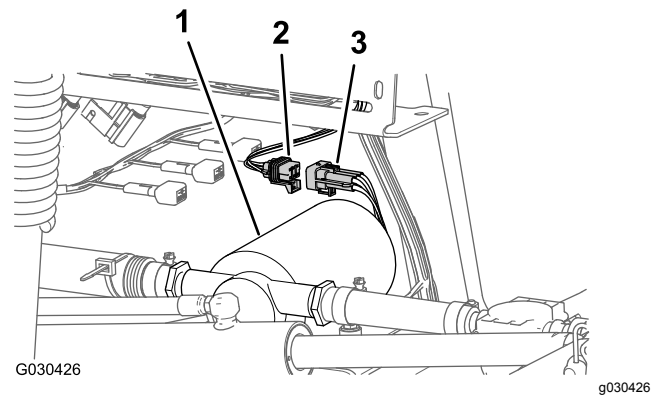

Figure 6

1. Rinse pump
2. 6-socket connector (rear, main harness)
3. 6-pin connector (rinse-pump harness)

Disconnecting the Pump for the Tank-Rinse Kit

1. At the back of the machine, press together the sides of the rinse-pump cover and lift the cover up until the tabs of the cover clear the slots in the saddle plate, and remove the cover from the machine (Figure 5).

3

Removing the Pressure Control Switch—Optional Pivoting Hose-Reel Kit

Parts needed for this procedure:

1	Switch plug (pivoting hose-reel kit—Toro Part No. 99-7420)
---	--

Procedure

1. Remove the 2 bolts (5/16 x 3/4 inch) and 2 locknuts (5/16 inch) that secure the control box to the reel-mounting plate (Figure 7).

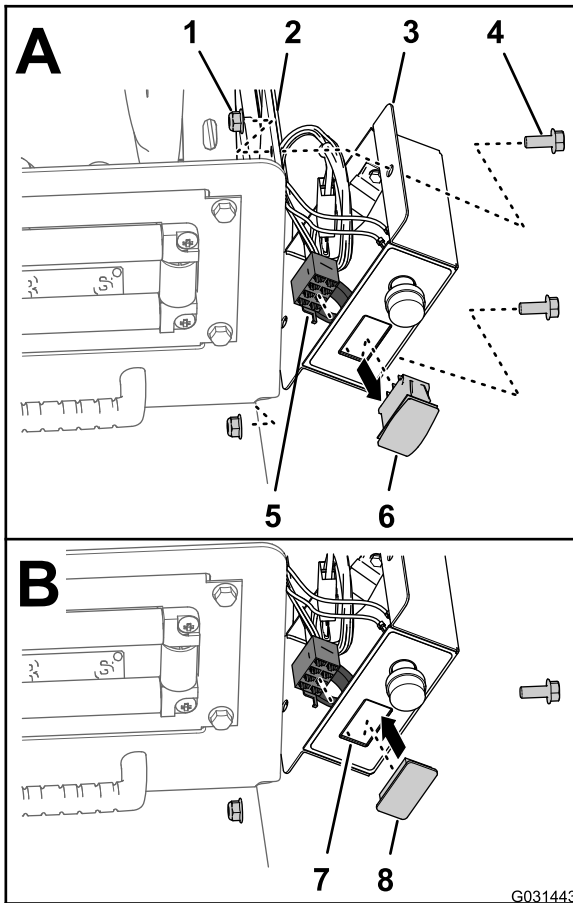

Figure 7

- | | |
|---------------------------|---|
| 1. Locknut (5/16 inch) | 5. 8-socket connector (control-box harness) |
| 2. Reel-mounting plate | 6. Pressure-control switch |
| 3. Control box | 7. Opening (control-box cover) |
| 4. Bolt (5/16 x 3/4 inch) | 8. Switch plug |

2. Disconnect the 8-socket connector for the control box harness from the PRESSURE-CONTROL switch (Figure 7).
3. Route the 8-socket connector inside the control box (Figure 7).
4. Squeeze the lock tabs of the PRESSURE-CONTROL switch and press the switch out of the control box (Figure 7).

Note: You no longer need the switch that you removed from the machine.

5. Align the switch plug to the opening in the control box where you removed the switch (Figure 7).
6. Insert the switch plug into the control box until the plug snaps into the cover securely (Figure 7).
7. Align the control box to the reel-mounting plate (Figure 7) and secure the box to the plate with the 2 bolts (5/16 x 3/4 inch) and 2 locknuts (5/16 inch).
8. Torque the bolts and nuts to 1978 to 2542 N·cm (175 to 225 in-lb).

4

Removing the Undercarriage Shroud

No Parts Required

Procedure

1. Remove the following hardware that secures the rear of the undercarriage shroud to the chassis of the machine (Figure 8):
 - **2016 machines**—7 flange-head bolts (5/16 x 7/8 inch) and 7 washers (5/16 inch)
 - **2017 and later machines**—5 flange-head bolts (5/16 x 7/8 inch) and 5 washers (5/16 inch)

Note: Retain the flange-head bolts and washers for installation in step 5 of 16 [Installing the Undercarriage Shroud \(page 45\)](#).

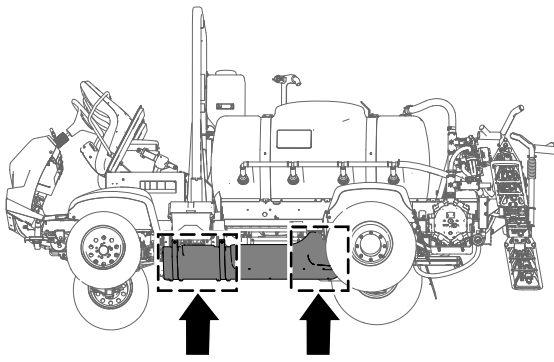

g189584

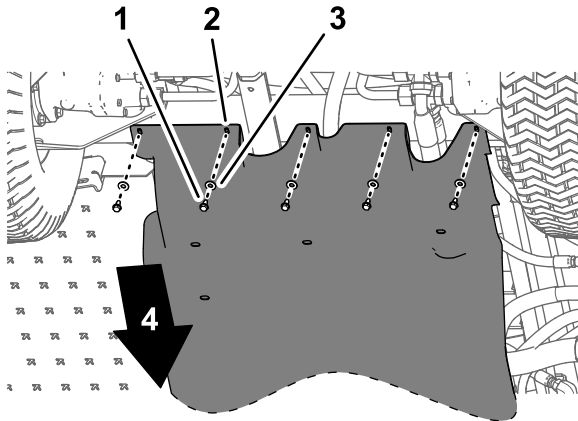

g189585

Figure 8

2017 machine shown; 2016 machines are similar

- | | |
|--|-------------------------|
| 1. Flange-head bolts (5/16 x 7/8 inch) | 3. Washers (5/16 inch) |
| 2. Undercarriage shroud | 4. Front of the machine |

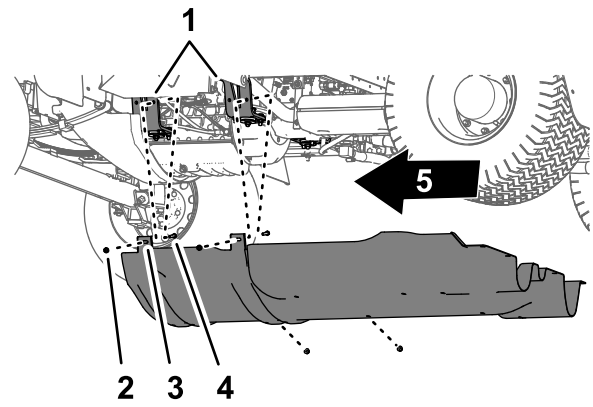

g189583

Figure 9

- | | |
|--|--------------------------------|
| 1. Engine mounts | 4. Flange locknuts (5/16 inch) |
| 2. Bolt—shown for clarity; do not remove | 5. Front of the machine |
| 3. Undercarriage shroud | |

-
3. Lift the support straps over the bolts that secure the undercarriage shroud to the engine-mount brackets.
 4. Remove the undercarriage shroud from the machine (Figure 8 and Figure 9).

Note: Do not remove the bolts from the machine. Retain the flange locknuts for installation in step 3 of [16 Installing the Undercarriage Shroud](#) (page 45).

5

Removing the Engine-Control Module and Mounting Bracket (Machine Models with a Gasoline Engine)

No Parts Required

Procedure

1. Remove the 3 flange head bolts and 1 flange nut that secure the mounting bracket for the engine-control module to the support bracket of the engine and accessory case of the engine (Figure 10).

Note: Retain the flange-head bolts and flange nut for installation in step 2 of [15 Installing the Engine-Control Module and Mounting Bracket \(Machine Models with a Gasoline Engine\)](#) (page 44).

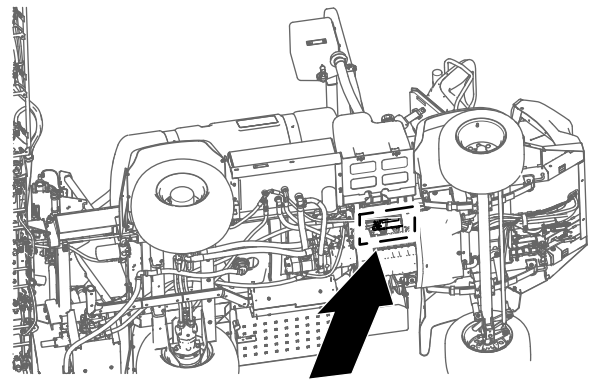

g189642

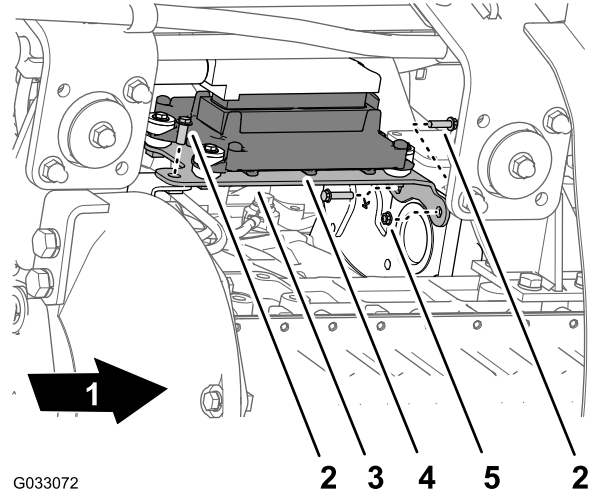

G033072

g033072

Figure 10

- | | |
|-------------------------|--------------------------|
| 1. Front of the machine | 4. Engine-control module |
| 2. Flange-head bolt | 5. Flange nut |
| 3. Mounting bracket | |

2. Move the engine-control module and mounting bracket down and rearward to provide access to the connectors of the front and rear wiring harnesses for the machine.

Note: Do not remove or disconnect the engine-control module from the engine.

6

Disconnecting the Pressure-Sense Tube for the Dash Gauge

No Parts Required

Disconnecting the Pressure-Sense Tube for the Dash Gauge—Machines Without an Optional Hose Reel Kit

Note: If your machine is equipped with an optional spray gun kit, refer to

1. Press in the collar for the tube coupler at the 90° elbow at the right boom-section valve ([Figure 11](#)).

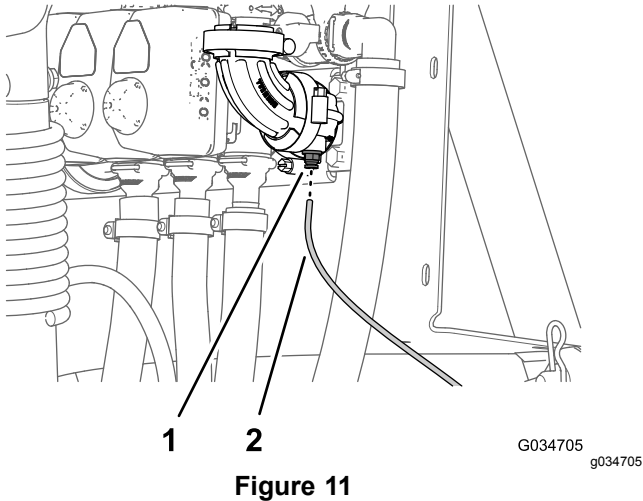

Figure 11

1. Tube coupler (90° elbow at the right boom-section valve)
2. Pressure-sense tube

2. Pull the pressure-sense tube for the dash pressure gauge out of the tube coupler ([Figure 11](#)).

Disconnecting Pressure-Sense Tube and Supply Hose—Optional Spray Gun Kit or Optional Pivoting Hose Reel Kit

1. Press in the collar for the tube coupler in the 90° elbow of the right boom-section valve ([Figure 12](#) or [Figure 13](#)).

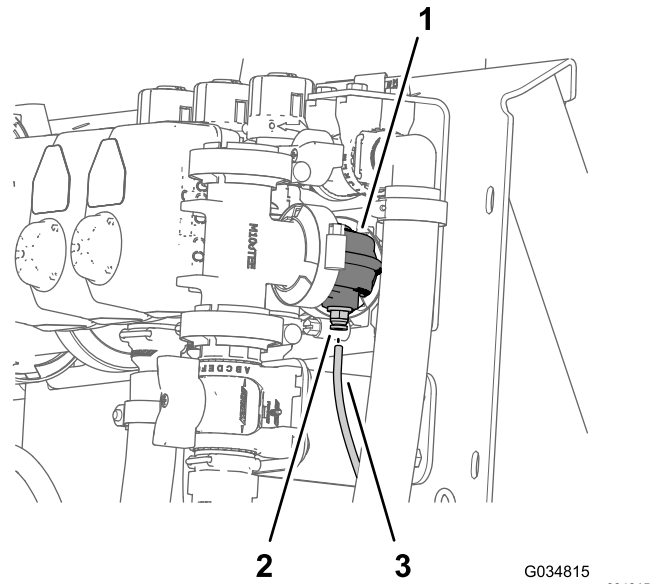

Figure 12

Optional Spray Gun Kit

1. 90° elbow (right boom-section valve)
2. Tube coupler
3. Pressure-sense tube (dash-pressure gauge)

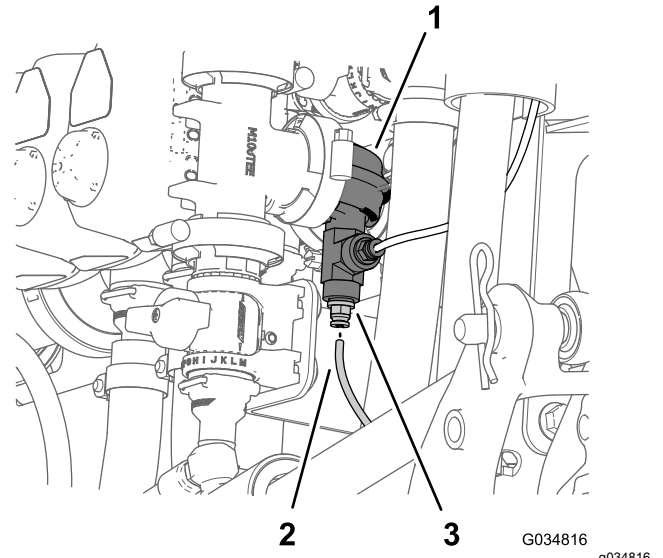

Figure 13

Optional Pivoting Hose-Reel Kit

1. 90° elbow (right boom-section valve)
2. Pressure-sense tube (dash-pressure gauge)
3. Tube coupler

2. Pull the pressure-sense tube for the dash pressure gauge out of the tube coupler ([Figure 12](#) or [Figure 13](#)).

Note: Do not remove the 90° elbow from the flange of the right boom-section valve.

7

Removing the Rear Wire Harness for the Machine

Parts needed for this procedure:

1	Rear wire harness
---	-------------------

Disconnecting the Front and Rear Wire Harnesses

Note: Use a machine hoist when disconnecting the front and rear wire harnesses.

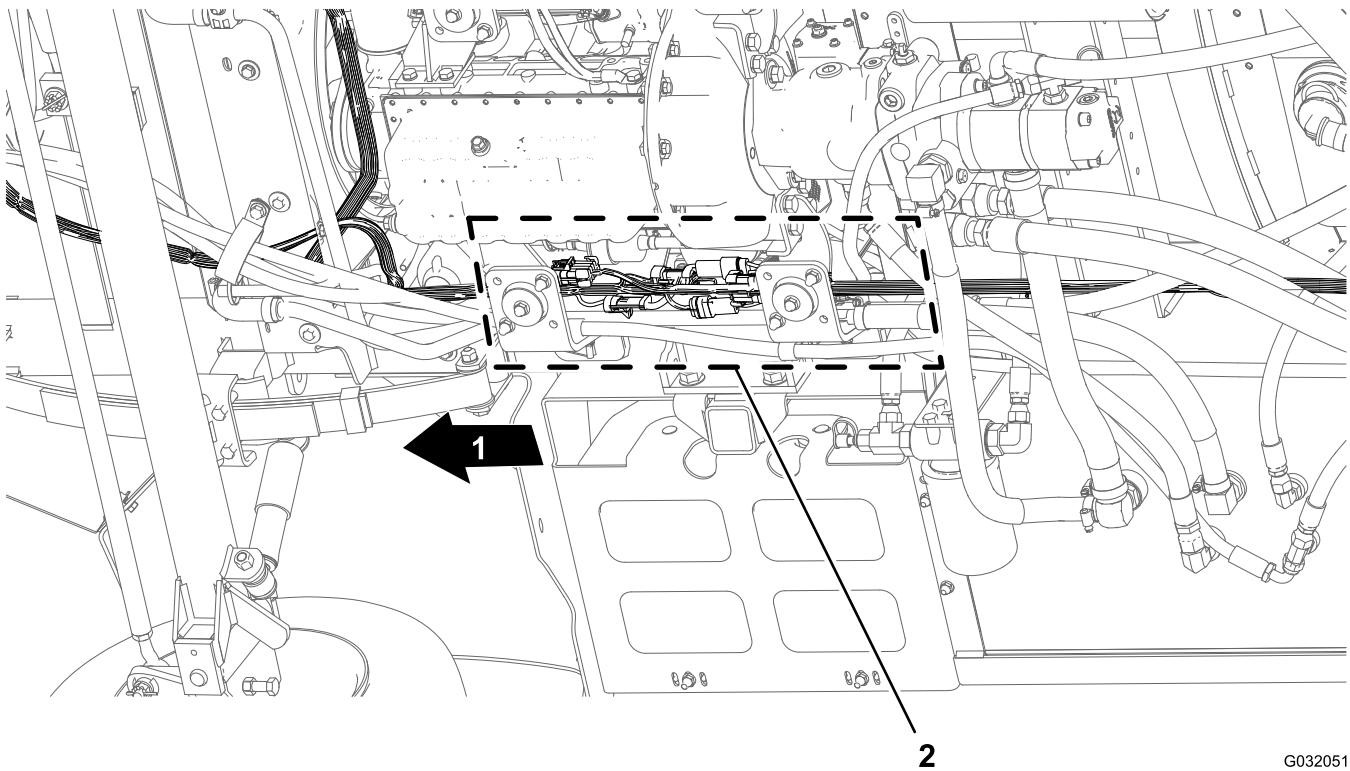

Figure 14

G032051
g032051

1. Front of the machine
2. Connector interfaces (front and rear wire harnesses)

1. From under the machine along the right frame tube, locate the electrical connectors for the front and rear wire harnesses of the machine (Figure 14).
2. Disconnect the 6 pairs of connectors between the front and rear wire harnesses as shown in Figure 15 through Figure 20.

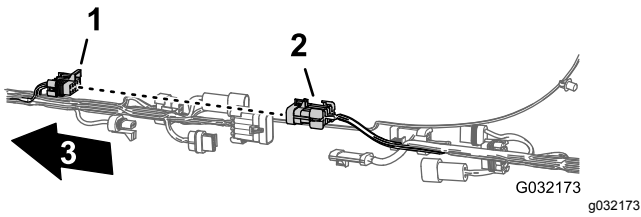

Figure 15

1. 10-pin connector—sprayer-harness interconnect (rear harness)
2. 10-socket connector—sprayer-harness interconnect (front harness)
3. Front of the machine

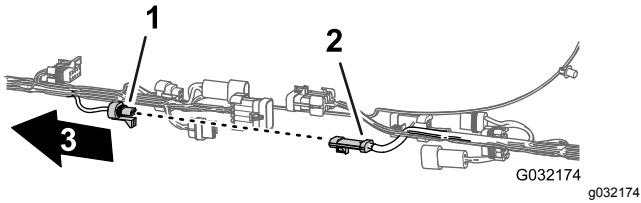

Figure 16

1. 3-pin connector—flow meter (rear harness)
2. 3-socket connector—flow meter (front harness)
3. Front of the machine

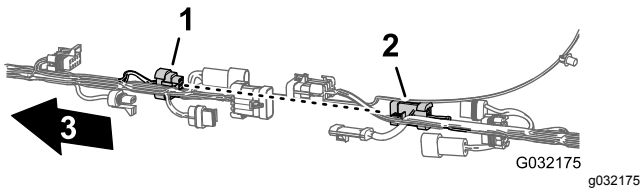

Figure 17

1. 8-pin connector—sprayer-harness interconnect (rear harness)
2. 8-socket connector—sprayer-harness interconnect (front harness)
3. Front of the machine

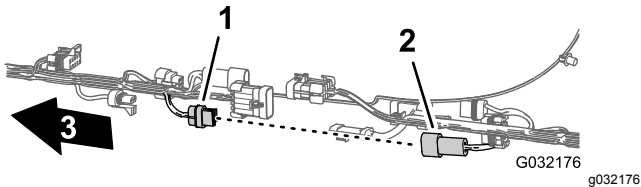

Figure 18

1. 2-pin connector—rinse pump (rear harness)
2. 2-socket connector—rinse pump (front harness)
3. Front of the machine

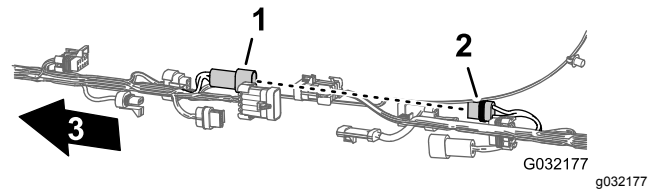

Figure 19

1. 2-pin connector—hose reel (front harness)
2. 2-socket connector—hose reel (rear harness)
3. Front of the machine

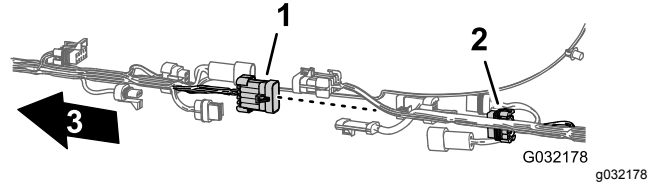

Figure 20

1. 10-pin connector—sprayer-harness interconnect (front harness)
2. 10-socket connector—sprayer-harness interconnect (rear harness)
3. Front of the machine

3. Remove the 3 push-in fasteners that secure the rear wire harness to the holes in the right frame tube of the machine (Figure 21).

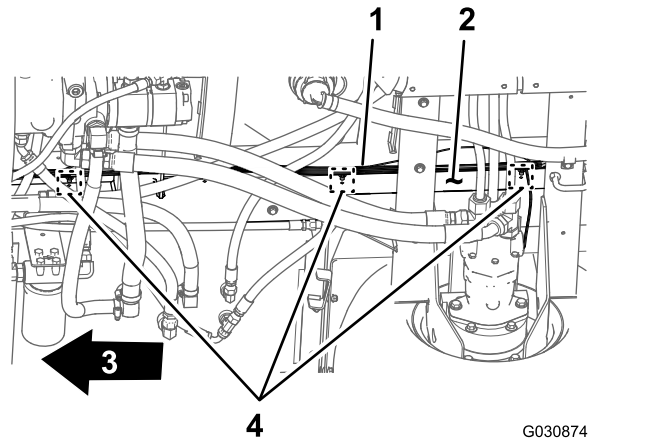

Figure 21

1. Rear wire harness
2. Right frame tube
3. Front of the machine
4. Push-in fasteners

Disconnecting the Connectors for the Components

- At back of the machine (between the right frame tube and the right fender) disconnect the 3-pin connector of the speed-sensor harness at the right hydraulic-traction motor from the 3-socket connector of the rear, main harness (Figure 22).

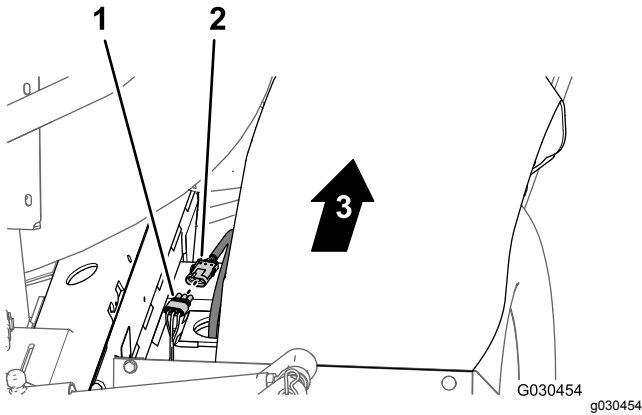

Figure 22

- 3-socket connector (rear, main harness)
- 3-pin connector (hydraulic-motor harness)
- Front of the machine

- At the back of the manifold mount, disconnect the 3-socket connector from the agitation valve and the 3-socket connectors from the 3 boom-section valves (Figure 23).

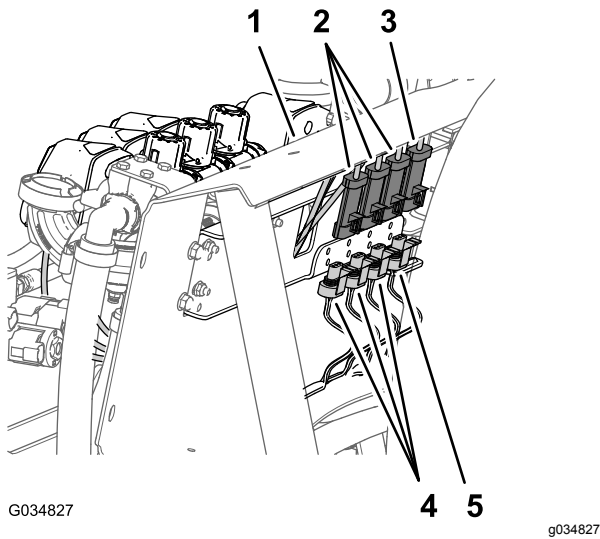

Figure 23

- Manifold mount
- 3-socket connectors (boom-section valve harnesses)
- 3-socket connector (agitation valve harness)
- 3-pin connectors (machine wire harness—rear)
- 3-pin connector (machine wire harness—rear)

- Remove the push-in fasteners that secure the rear wire harness to the holes at the forward side and lower plate of the manifold mount (Figure 24).

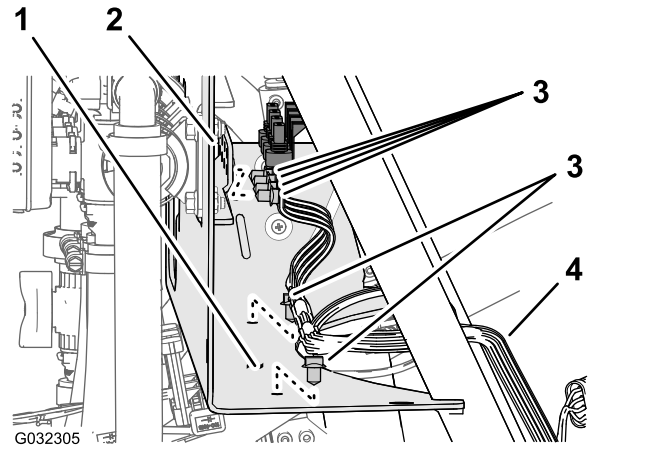

Figure 24

- Manifold mount (lower side)
- Manifold mount (forward side)
- Push-in fasteners
- Rear wire harness

- For machines with the ExcelsaRate sprayer system, disconnect the 3-socket connector of the rear-wire-harness from the 3-pin connector of the pressure transducer (Figure 25).

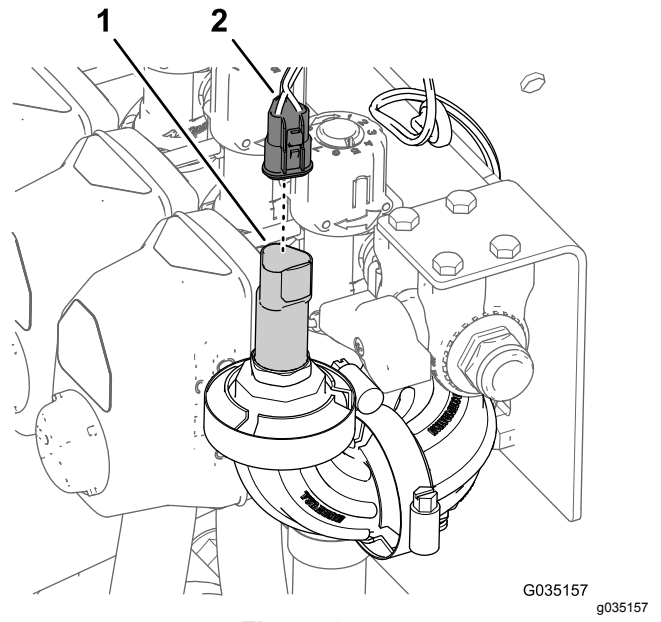

Figure 25

- 3-pin connector (pressure transducer)
- 3-socket connector (rear-wire-harness)

- At the back of the machine, disconnect the following 2-socket connectors (Figure 26) for the lift-cylinder manifold as follows:

- Right—up solenoid

- Left—up solenoid
- Enable solenoid
- Right—down solenoid
- Left—down solenoid

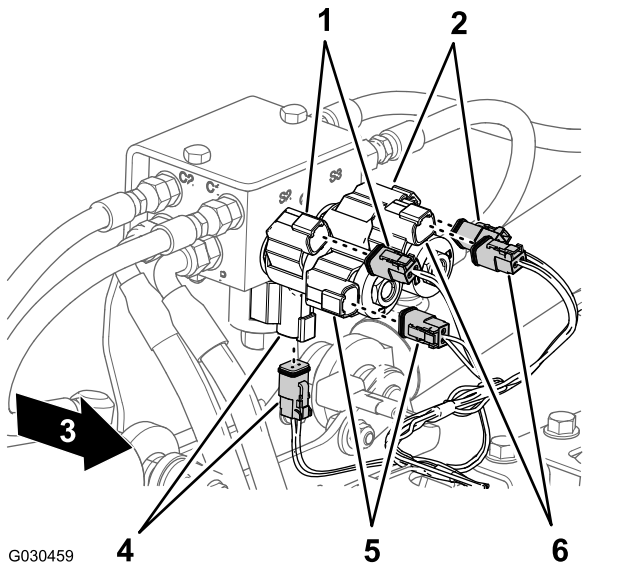

Figure 26

- | | |
|---|---|
| 1. Right—up (solenoid and main-harness connector) | 4. Enable (solenoid and main-harness connector) |
| 2. Left—up (solenoid and main-harness connector) | 5. Right—down (solenoid and main-harness connector) |
| 3. Front of the machine | 6. Left—down (solenoid and main-harness connector) |

6. At the back of the machine—inboard of the sprayer pump, disconnect the 2-socket connector of the rear, main harness from the 2-pin connector of the relay for the pump (Figure 27).

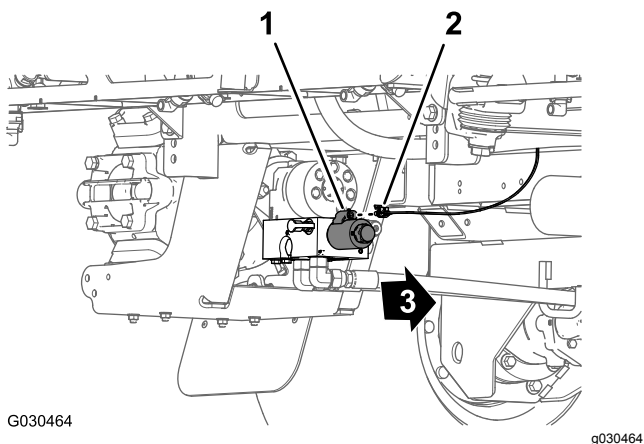

Figure 27

- | | |
|--|-------------------------|
| 1. 2-pin connector (pump relay) | 3. Front of the machine |
| 2. 2-socket connector (rear, main harness) | |

7. Remove the push-in fastener that secures the rear wire harness (Figure 28) to the holes in the rear cross tube (rearward of the hydraulic-traction motors).

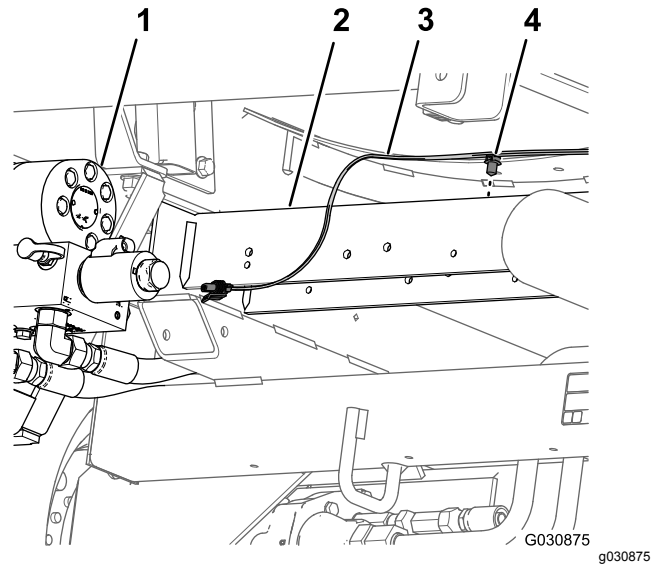

Figure 28

- | | |
|--------------------|----------------------|
| 1. Sprayer pump | 3. Rear wire harness |
| 2. Rear cross tube | 4. Push-in fastener |

8. Remove the pressure-sense tube for the dash gauge from the rear wire harness from the machine (Figure 29).

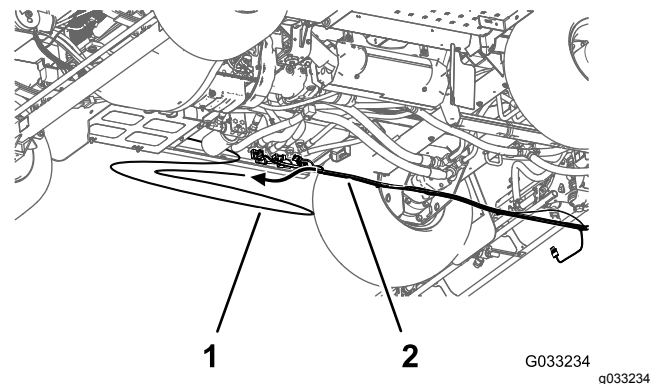

Figure 29

- | | |
|-------------------------------------|----------------------|
| 1. Pressure-sense tube (dash gauge) | 2. Rear wire harness |
|-------------------------------------|----------------------|

9. Remove the rear wire harness from the machine.

Note: You no longer need the rear-main harness that you removed from the machine.

8

Removing the Rate-Control Switch

Parts needed for this procedure:

1	Cable tie
1	Switch plug

Procedure

1. From under the dash panel of the machine, squeeze the lock tabs of the rate-control switch together and push up the rate-control switch out of the dash panel (Figure 30).

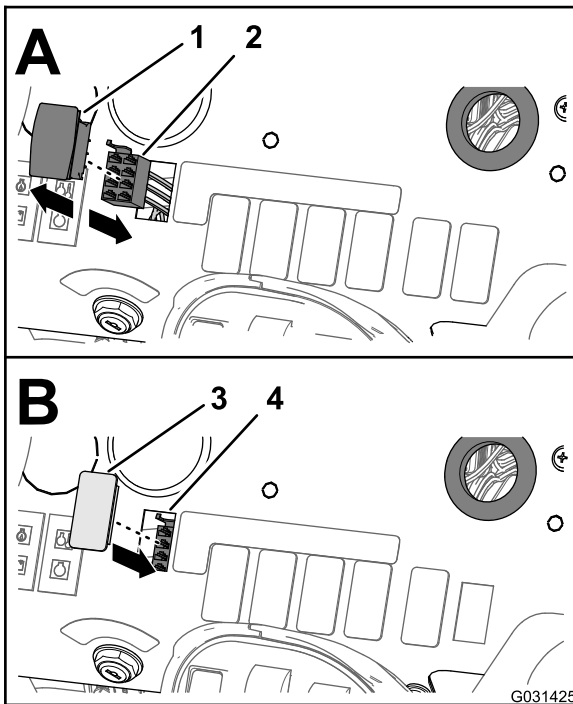

Figure 30

- | | |
|--------------------------------------|-------------------------|
| 1. Rate-control switch | 3. Switch plug |
| 2. 8-socket connector(front harness) | 4. Opening (dash panel) |

2. Disconnect the 8-socket connector of the front harness of the machine (labeled **Rate Switch**) from the 8-pin connector of the switch (Figure 30).

Note: You no longer need the rate switch that you removed from the machine.

3. Route the branch of the front harness for the rate switch through the opening in the dash

and secure the wiring branch against the front harness with a cable tie.

4. Align the switch plug to the opening in the dash panel where you removed the rate switch (Figure 30).
5. Insert the switch plug into the dash panel until the plug snaps into the panel securely (Figure 30).

9

Removing the Boom-Section Valves

Parts needed for this procedure:

1	Fitting cap
3	Cap (quick coupler)
3	Retainer

Removing the Pressure Transducer from the Section Valve

Machines with the ExcelsaRate Sprayer System

1. Remove the flange clamp that secures the ported-fitting cap, pressure transducer, and gasket to the 90° elbow at the end of the right-section valve, and remove the cap, transducer, and gasket (Figure 31).

Note: Retain the pressure transducer and ported-fitting cap, gasket, and clamp for installation in [Assembling the Pressure Transducer to the Manifold \(page 27\)](#).

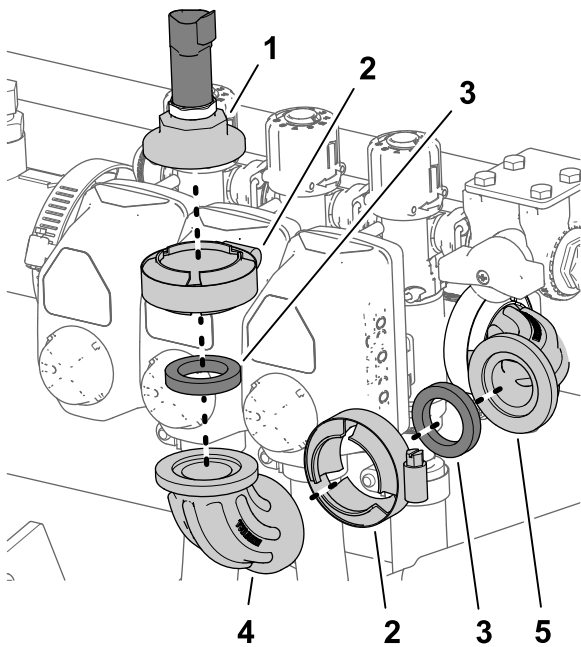

Figure 31

g187815

- | | |
|---|---|
| 1. Pressure transducer and ported-fitting cap | 4. 90° elbow (non-ported—right-section valve) |
| 2. Flange clamp | 5. Ported 90° elbow |
| 3. Gasket | |

- Remove the flange clamp, 90° elbow (non-ported), and gasket from the ported 90° elbow (Figure 31).

Note: Retain the flange clamp and gasket for installation in 3.

- Align the fitting cap, and gasket to the flange of the 90° elbow at the end of the right-section valve (Figure 31).

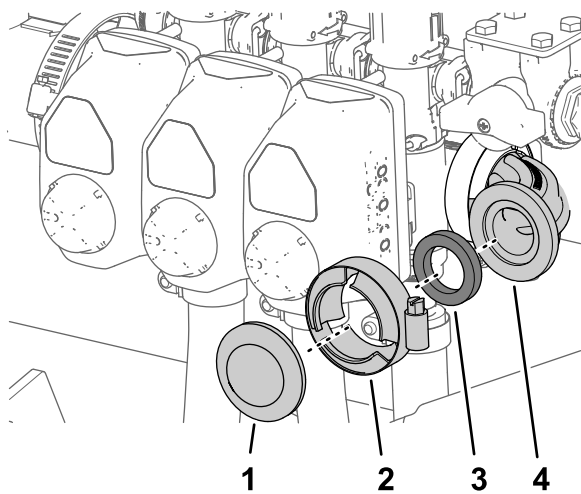

Figure 32

g187813

- | | |
|-----------------|---------------------|
| 1. Fitting cap | 3. Gasket |
| 2. Flange clamp | 4. Ported 90° elbow |

- Secure the fitting cap and gasket to the 90° elbow with the flange clamp (Figure 31).

Removing the Coupling Tube and Reducer Adapter

- Loosen the 4 flange-head bolts (1/4 x 3/4 inch) and 4 flange locknuts (1/4 inch) that secure the 3 section valves to the manifold mount (Figure 33).

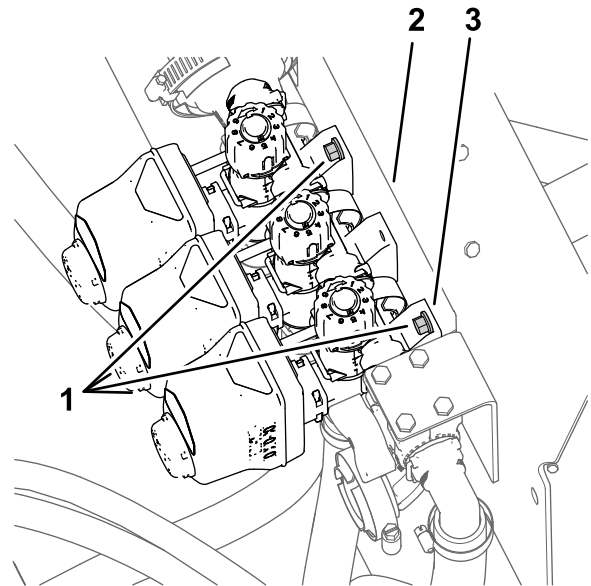

Figure 33

g187814

- | | |
|---------------------------------------|-------------------|
| 1. Flange-head bolts (1/4 x 3/4 inch) | 3. Manifold mount |
| 2. Valve housing (section valve) | |

- For machines **without** the ExcelsaRate sprayer system, remove the coupling tube as follows:

- Remove the 2 flange clamps that secure the coupling tube to the reducer adapters at the master-control valve and left boom-section valve (Figure 34).

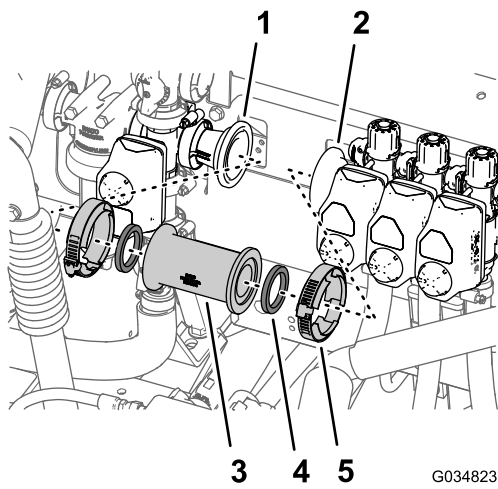

Figure 34

- | | |
|---|-----------------|
| 1. Reducer adapter (at the master-control valve) | 4. Gasket |
| 2. Reducer adapter (at the left boom-section valve) | 5. Flange clamp |
| 3. Coupling tube | |

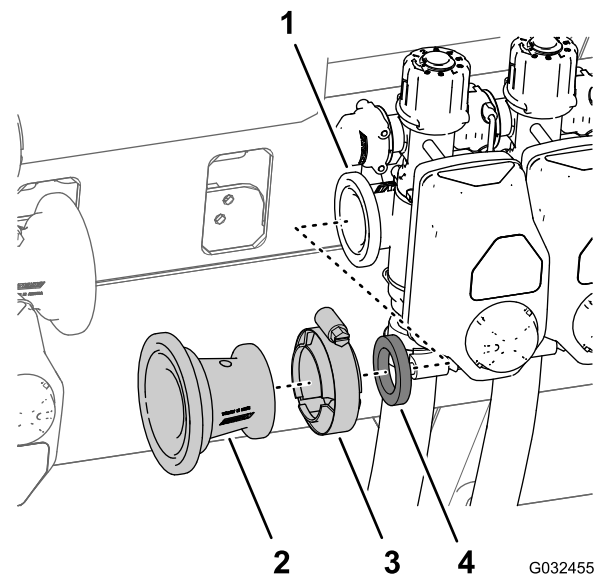

Figure 35

- | | |
|-------------------------------------|--|
| 1. Flange (left boom-section valve) | 3. Flange clamp 51 mm (2 inches) |
| 2. Reducer adapter | 4. Gasket (1-5/16 inch outside diameter) |

B. Remove the straight coupler and 2 gaskets from the machine (Figure 34).

Note: Retain clamps and gaskets for installation in steps 1A and 1B of [Assembling the Flow Meter](#) (page 26).

C. Remove the flange clamp 76 mm (3 inches) that secures the reducer adapter and gasket (2-1/4 inches) to the flange of the left boom-section valve, and remove the adapter, clamp and gasket from the machine (Figure 35).

Note: Retain reducer adapter for installation in steps 1C of [Assembling the Flow Meter](#) (page 26).

3. For machines **with** the ExcelsaRate sprayer system, remove the flange clamp and gasket that secures the reducer adapter to the left boom-section valve (Figure 36).

Note: Do not remove the reducer adapter or the flow meter.

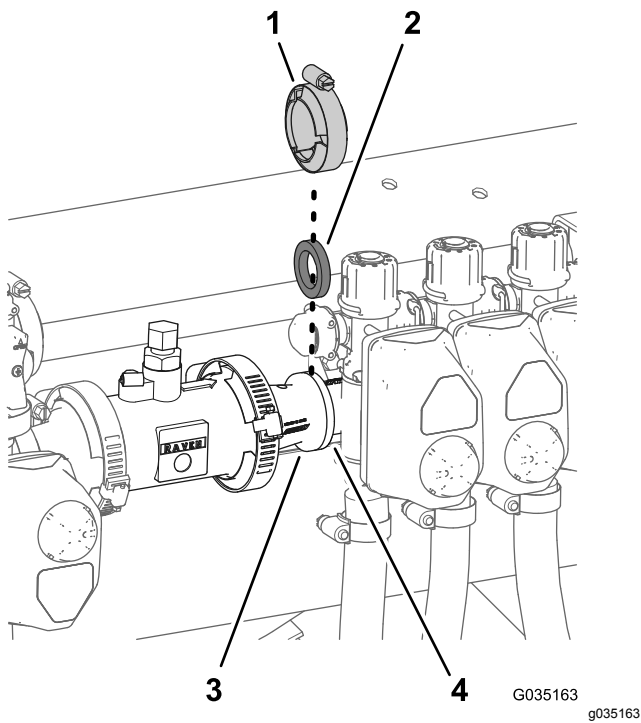

Figure 36

- | | |
|--|-------------------------------------|
| 1. Flange clamp 51 mm (2 inches) | 3. Reducer adapter |
| 2. Gasket (1-5/16 inch outside diameter) | 4. Flange (left boom-section valve) |

Removing the Boom-Section Hoses

- At the outer-boom section, remove the hose clamp that secures the supply hose for the boom section to the barbed T-fitting ([Figure 37](#)).

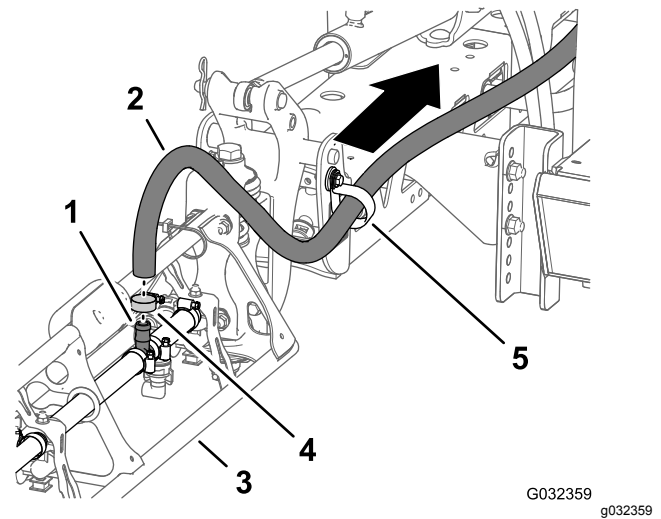

Figure 37

- | | |
|-------------------------------------|---------------|
| 1. Barbed T-fitting | 4. Hose clamp |
| 2. Supply hose (outer-boom section) | 5. R-clamp |
| 3. Outer-boom section | |

- Remove the hose from the T-fitting ([Figure 37](#)).
- Remove the free end of the hose from the R-clamp ([Figure 37](#)).
- Repeat steps 1 through 3 for the supply hose at the other outer-boom section.
- Under the center-boom section, remove the hose clamp that secures the supply hose for the boom section to the barbed T-fitting ([Figure 38](#)).

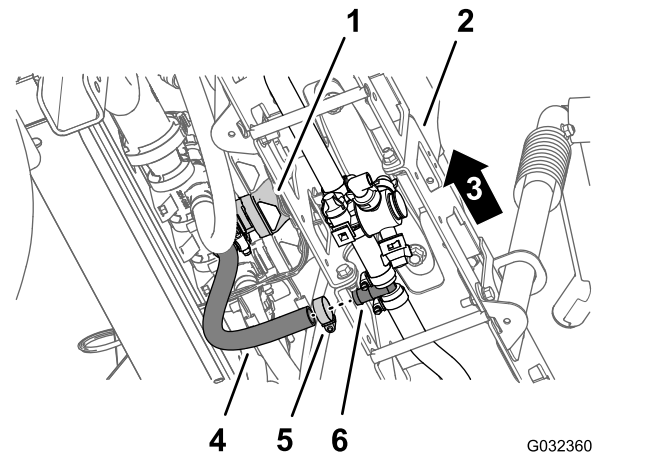

Figure 38

- | | |
|------------------------------|-------------------------------|
| 1. Center boom-section valve | 4. Hose (center-boom section) |
| 2. Center-boom section | 5. Hose clamp |
| 3. Left side of the machine | 6. Barbed T-fitting |

- Remove the retainers that secure the straight barbed fittings to the quick disconnect fittings of the left, center, and right boom-section valves ([Figure 39](#)).

Note: Retain the retainers for installation in [Assembling the Hoses to Nozzle Valves 5 and 6](#) (page 35).

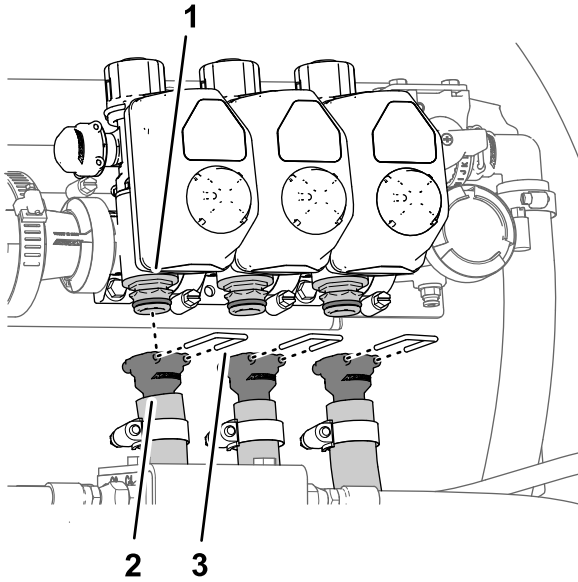

Figure 39

g187838

1. Quick-disconnect fitting (boom-section valve)
2. Straight barbed fitting
3. Retainer

7. Remove the hoses for the left, center, and right boom-section valves from the machine ([Figure 39](#)).

Note: You no longer need the hoses for the left, center, and right boom-section valves.

Removing the Bypass Hoses

1. At the lower end of the upper bypass hose, remove the flange-head bolt (5/16 x 3/4 inch), washer (5/16 inch), and R-clamp that secures the upper bypass hose to the rear-saddle plate of the machine ([Figure 40](#) and [Figure 41](#)).

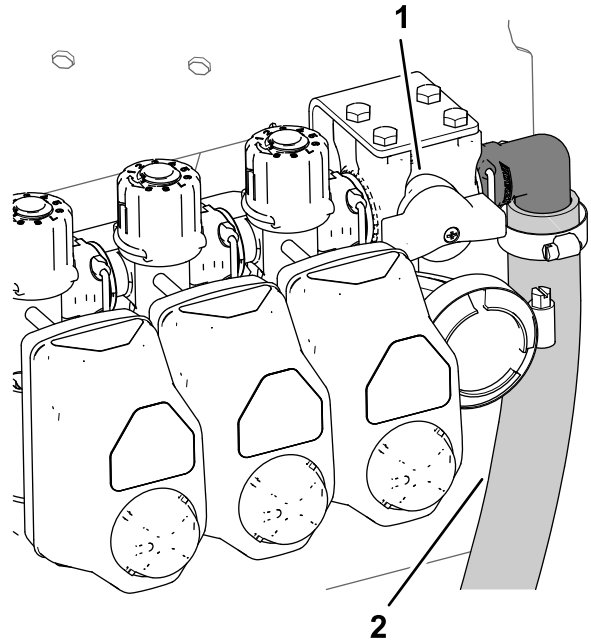

Figure 40

g187826

1. Bypass-shutoff valve
2. Upper bypass hose

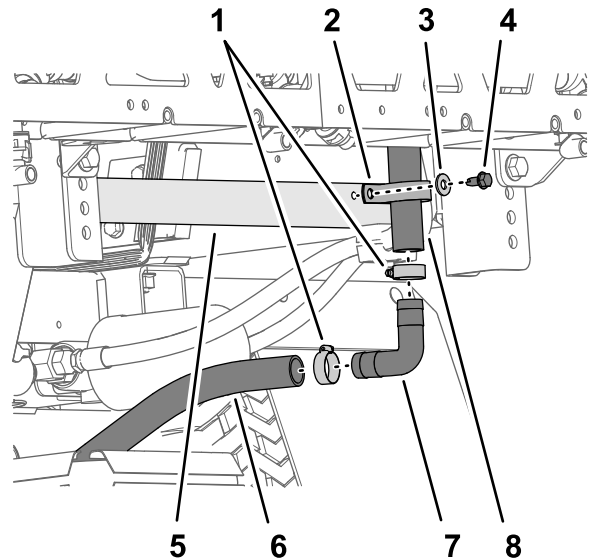

Figure 41

g189630

1. Hose clamp
2. R-clamp
3. Washer (5/16 inch)
4. Flange-head bolt (5/16 x 3/4 inch)
5. Rear-saddle plate (chassis frame)
6. Lower bypass hose
7. 90° barbed fitting
8. Upper bypass hose

2. Remove the 2 hose clamps that secure the upper bypass hose and the lower bypass hose to the 90° barbed fitting (Figure 41).
 3. Remove the 90° barbed fitting from the hoses (Figure 41).
- Note:** Retain the 90° barbed fitting and 2 clamps for installation in steps 8 and 9.
4. Remove the hose clamps that secure the drain-valve hose and the rear tank-drain hose to the barbed T-fitting (Figure 42 and Figure 43).

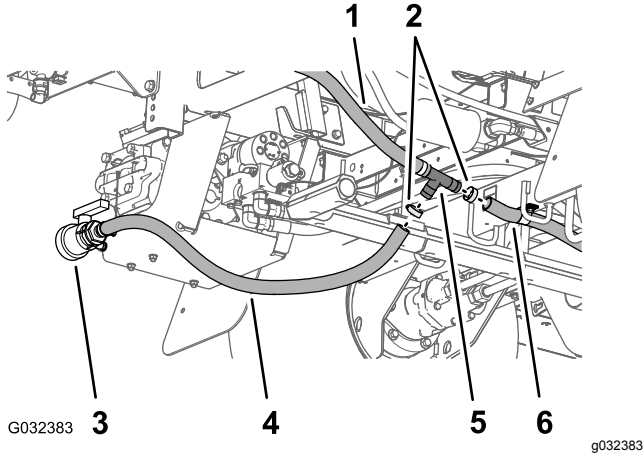

Figure 42
2016 Machine

- | | |
|----------------------|-------------------------|
| 1. Lower bypass hose | 4. Drain-valve hose |
| 2. Hose clamp | 5. Barbed T-fitting |
| 3. Drain valve | 6. Rear tank-drain hose |

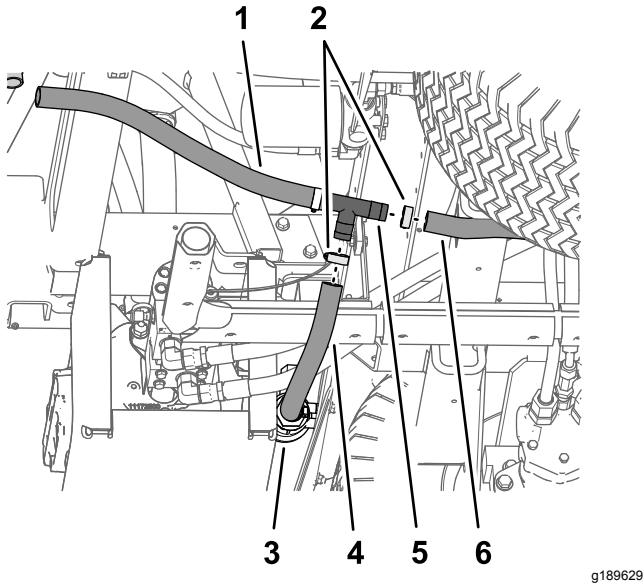

Figure 43
2017 and later machine

- | | |
|----------------------|-------------------------|
| 1. Lower bypass hose | 4. Drain-valve hose |
| 2. Hose clamp | 5. Barbed T-fitting |
| 3. Drain valve | 6. Rear tank-drain hose |

5. Remove the T-fitting from the drain-valve hose from the rear tank-drain hose (Figure 42 and Figure 43).
6. Remove the retainer that secures the 90° barbed fitting of the bypass hose to the quick-disconnect fitting of the bypass valve at the right boom-section valve, and separate the hose and valve fittings (Figure 44).

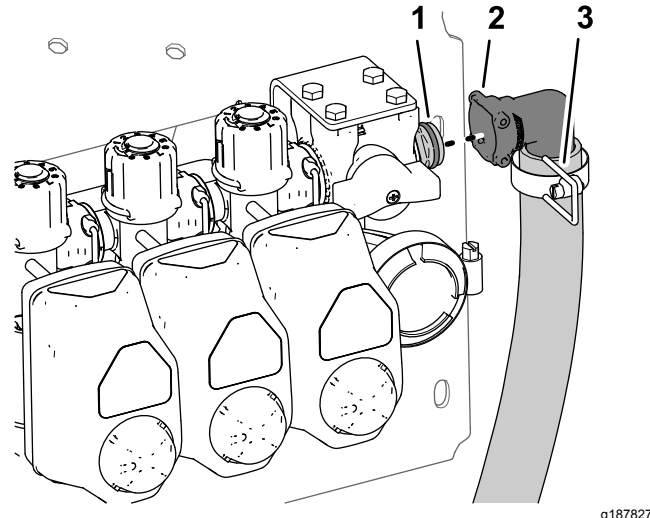

Figure 44

- | | |
|--|-------------|
| 1. Quick-disconnect fitting (bypass-shutoff valve) | 3. Retainer |
| 2. 90° barbed fitting | |

7. Remove the upper and lower bypass hoses from the machine (Figure 45).

Note: You no longer need the shutoff valve, T-fitting, upper bypass hose, and lower bypass hose.

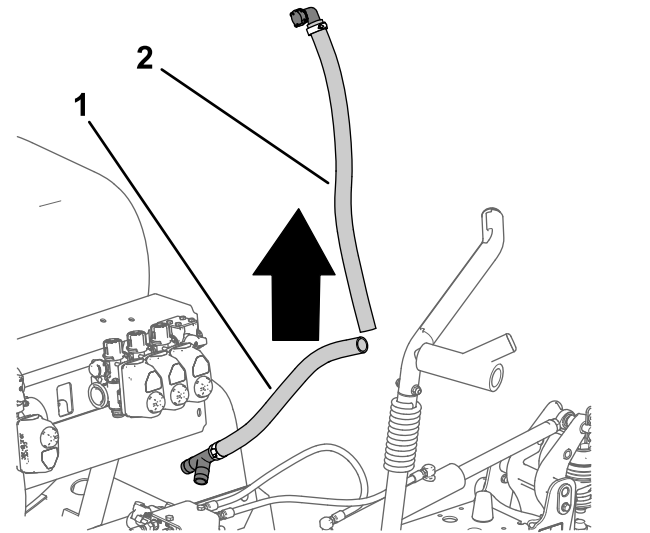

Figure 45

- | | |
|----------------------|----------------------|
| 1. Lower bypass hose | 2. Upper bypass hose |
|----------------------|----------------------|

- Insert the 90° barbed fitting that you removed in step 3 into the drain-valve hose and the rear tank-drain hose (Figure 46 and Figure 47).

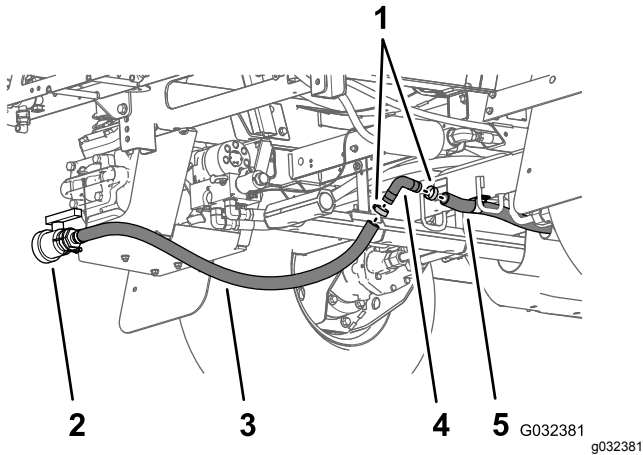

Figure 46
2016 Machines

- | | |
|---------------------|-------------------------|
| 1. Hose clamp | 4. 90° barbed fitting |
| 2. Drain valve | 5. Rear tank-drain hose |
| 3. Drain-valve hose | |

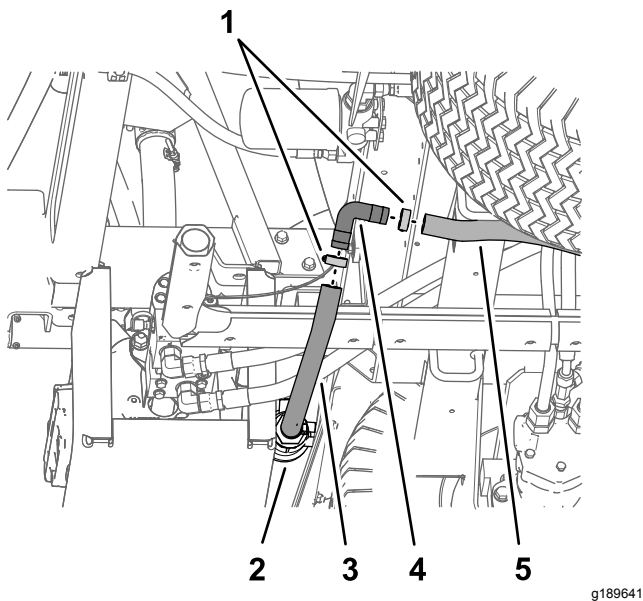

Figure 47
2017 and later machines

- | | |
|---------------------|-------------------------|
| 1. Hose clamp | 4. 90° barbed fitting |
| 2. Drain valve | 5. Rear tank-drain hose |
| 3. Drain-valve hose | |

- Secure the 90° barbed fitting and drain hoses with the 2 hose clamps that you removed in step 2 (Figure 46 and Figure 47).

Removing the Valve Actuator

- Remove the retainer that secures the actuator to the manifold valve of the section valve assembly (Figure 48).

Note: Squeeze the 2 legs of the retainer together while pushing it down.

Note: Retain the actuator and retainer for installation in steps 8 and 9 of [Removing Bypass Shutoff Valve and Installing the Bypass Valve with Caps](#) (page 23).

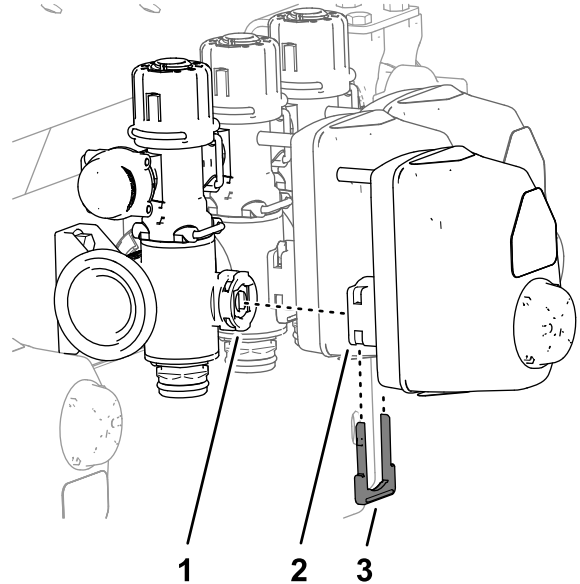

Figure 48

- | | |
|-------------------------------|-------------|
| 1. Stem port (manifold valve) | 3. Retainer |
| 2. Actuator (section valve) | |

- Remove the actuator from the manifold valve (Figure 48).
- Repeat steps 1 and 2 for the 2 other valve actuators.

Removing Bypass Shutoff Valve and Installing the Bypass Valve with Caps

- Remove the 4 bolts (6 x 12 mm) that secure the bypass-shutoff valve to the valve-support bracket (Figure 49).
- Remove the retainer that secures the bypass-shutoff valve to the bypass valve for the right boom section valve, and remove the shutoff valve (Figure 49).

Note: You no longer need the bypass-shutoff valve and the 4 bolts (6 x 12 mm).

- Remove the 3 retainers that secure the 3 bypass valves to the 3 manifold valves (Figure 49).

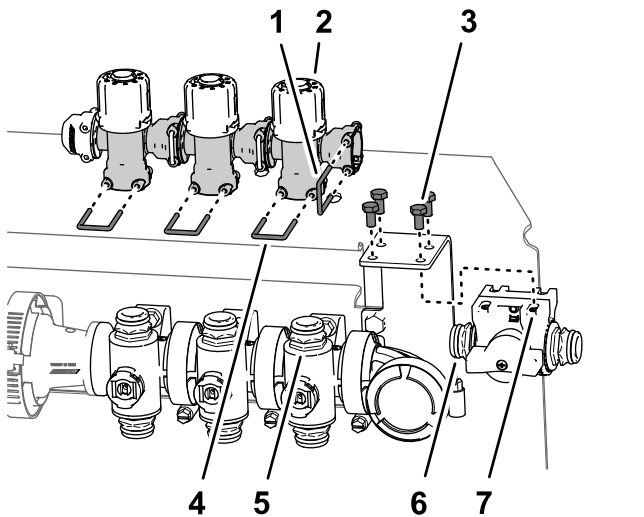

Figure 49

g187902

- | | |
|---------------------|---|
| 1. Retainer | 4. Quick coupler (manifold valve) |
| 2. Bypass valves | 5. Quick coupler (bypass-shutoff valve) |
| 3. Bolt (6 x 12 mm) | 6. Bypass-shutoff valve |

4. Lift the 3 bypass valves from the 3 quick couplers of the manifold valves (Figure 49).

Note: You no longer need the bypass valves.

5. Lubricate the upper and lower O-rings on the quick coupler of the manifold valve with the grease provided with the quick-coupler cap (Figure 50).

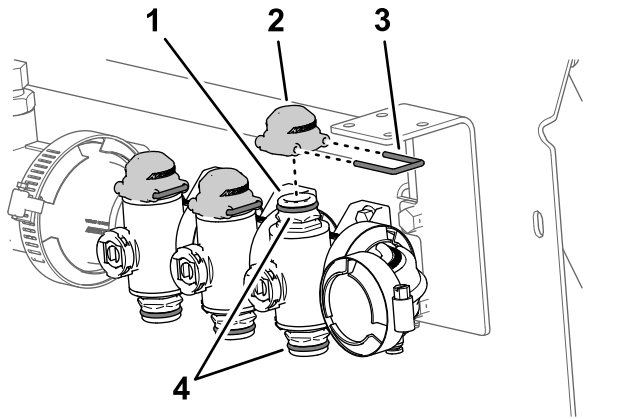

Figure 50

g187927

- | | |
|-----------------------------------|-------------|
| 1. Quick coupler (manifold valve) | 3. Retainer |
| 2. Cap (quick coupler) | 4. O-rings |

6. Assemble the 3 caps for the quick couplers onto the 3 quick couplers for the manifold valves (Figure 50).

7. Secure the 3 caps to the 3 quick couplers with the 3 retainers (Figure 50).

8. Align the coupler of the section valve actuator that you removed in step 2 of [Removing the Valve Actuator \(page 23\)](#) with the stem port of the manifold valve (Figure 51).

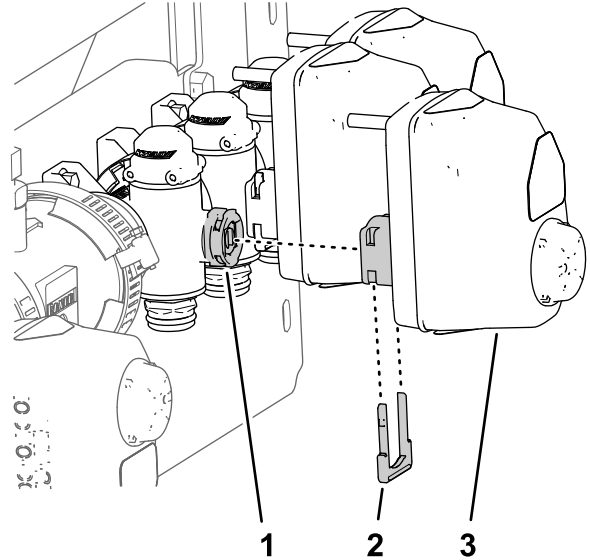

Figure 51

g187925

- | | |
|-------------------------------------|-------------------------------|
| 1. Retainer | 3. Stem port (manifold valve) |
| 2. Coupler (section-valve actuator) | |

9. Secure the section valve actuator to the manifold valve with a retainer (Figure 51) that you removed in step 1 of [Removing the Valve Actuator \(page 23\)](#).

Disassembling the Boom-Section Valves from the Manifold Mount

Note: You will add the boom-section valves to the valves for the 10-valve system in [Assembling Sprayer Valves 8, 9, and 10 to the Valve Mount \(page 30\)](#).

1. Remove the 2 flange-head bolts (1/4 x 3/4 inch) and 2 locknuts (1/4 inch) that secure the right boom-section valve to the manifold mount (Figure 52).

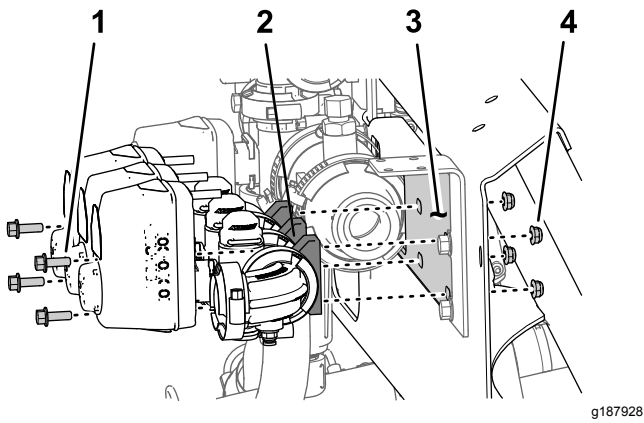

Figure 52

- | | |
|---------------------------------------|-----------------------|
| 1. Flange-head bolt (5/16 x 3/4 inch) | 3. Manifold mount |
| 2. Boom-section valve | 4. Locknut (1/4 inch) |

- Remove the 2 flange-head bolts (1/4 x 3/4 inch) and 2 locknuts (1/4 inch) that secure the left boom-section valve to the manifold mount (Figure 52).
- Remove the boom-section valves from the manifold mount and set aside the valves (Figure 52).

Note: Retrain the boom-section valves for installation in steps 1 of [Assembling Sprayer Valves 8, 9, and 10 to the Valve Mount](#) (page 30). Discard the 4 flange-head bolts and 4 locknuts.

- Remove the 6 decals from the 3 boom-section valves (Figure 53).

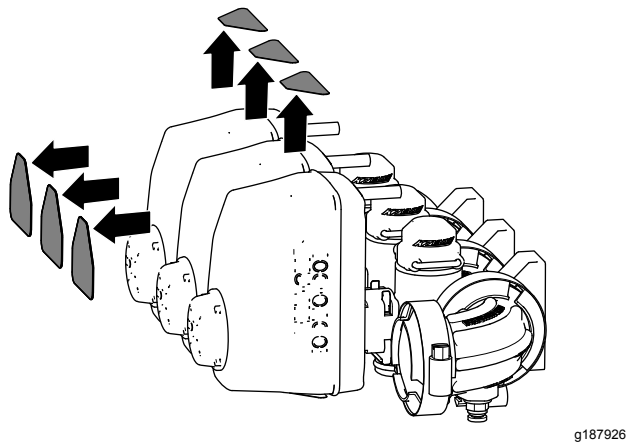

Figure 53

- Remove the 2 flange-head bolts (5/16 x 1 inch) and 2 flange locknuts (5/16 inch) that secure the support bracket for the bypass-shutoff valve to the manifold mount (A of Figure 54), and remove the shutoff-valve bracket.

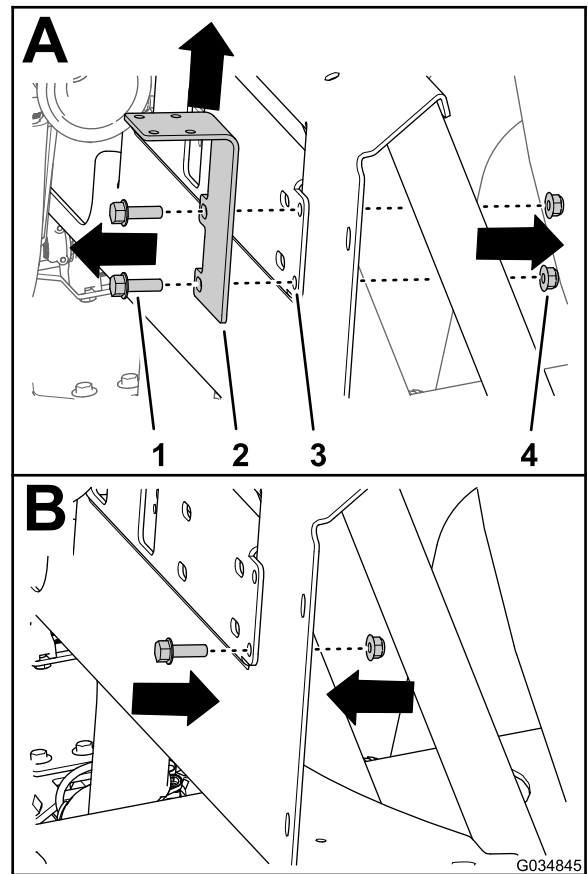

Figure 54

- | | |
|---|--------------------------------|
| 1. Flange-head bolt (5/16 x 1 inch) | 3. Manifold mount |
| 2. Support bracket (bypass-shutoff valve) | 4. Flange locknuts (5/16 inch) |

- Assemble a flange-head bolt (5/16 x 1 inch) and flange locknut (5/16 inch) to the manifold mount (B of Figure 54) at the lower hole position for the shutoff-valve bracket that you removed in step 5.

Note: Retain the other flange-head bolt and flange locknut for installation in step 3 of [Installing the Pressure Transducer onto the Machine](#) (page 28).

- Torque the flange bolt and flange nut to 1978 to 2542 N·cm (175 to 225 in-lb).

10

Installing the Flow Meter and Pressure Transducer

Parts needed for this procedure:

1	Flow meter (for 2016 machines without the ExcelsaRate sprayer system only)—not included in this kit; order Toro Part No. 106-1038.
1	Flange clamp 51 mm (2 inches)
1	Gasket (1-5/16 inch outside diameter)
1	Barbed-flange fitting (1 inch)
1	Hose (1 x 7-1/4 inches)
3	Hose clamp
1	Pressure transducer (for 2016 machines without the ExcelsaRate sprayer system only)—not included in this kit; order Toro Part No. 130-8202.
1	Fitting cap—ported (for 2016 machines without the ExcelsaRate sprayer system only)—not included in this kit; order Toro Part No. 127-1185.
1	Manifold
1	Hose (1 x 8-1/2 inches)
1	R-clamp

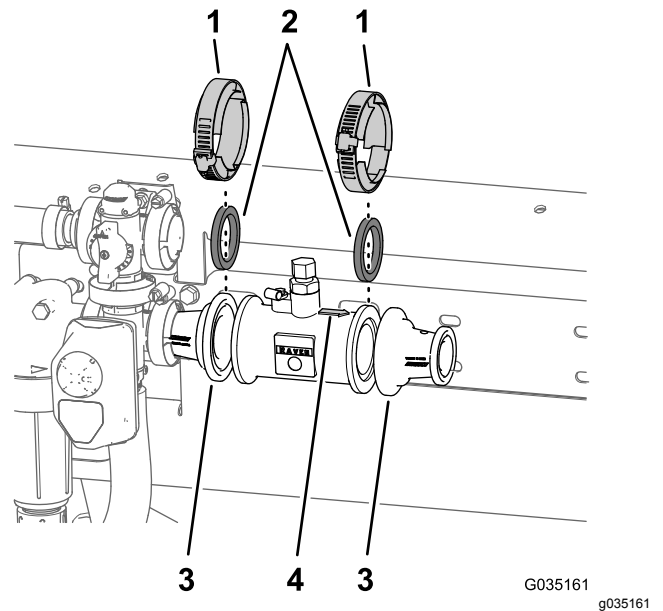

Figure 55

1. Flange clamp 76 mm (3 inches)
2. Gasket (2-1/4 inch outside diameter)
3. Reducer adapter (3 inches)
4. Directional arrow (flow meter)

Assembling the Flow Meter

1. For machines **without** the ExcelsaRate sprayer system, perform the following steps:
 - A. Align the gasket (2-1/4 inches) that you removed in step 2 B of [Removing the Coupling Tube and Reducer Adapter \(page 18\)](#) between the flow meter and the reducer adapter that is installed at the right side of the master-control valve ([Figure 55](#)).
 - B. Loosely assemble the gasket, flow meter, and reducer adapter ([Figure 55](#)) with a flange clamp 76 mm (3 inches) that you removed in step 2A of [Removing the Coupling Tube and Reducer Adapter \(page 18\)](#).
 - C. Align the gasket (2-1/4 inches) and reducer adapter that you removed in step 2C of [Removing the Coupling Tube and Reducer Adapter \(page 18\)](#) to the end of the flow meter to which the directional arrow points ([Figure 55](#)).
 - D. Assemble the gasket, flow meter, and reducer adapter ([Figure 55](#)) with a flange clamp 76 mm (3 inches) that you removed in step 2A of [Removing the Coupling Tube and Reducer Adapter \(page 18\)](#).
2. Align the gasket (1-5/16 inch) that you removed in step and barbed hose fitting to the end of the reducer adapter ([Figure 56](#)).

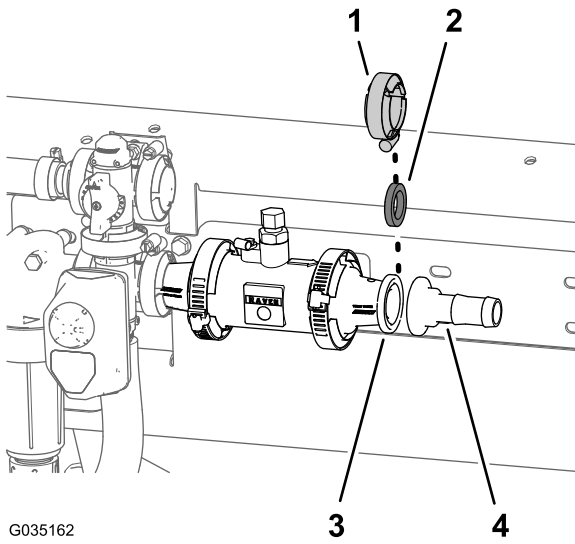

Figure 56

- | | |
|----------------------------------|--|
| 1. Flange clamp 51 mm (2 inches) | 3. Gasket (1-5/16 inch outside diameter) |
| 2. Barbed hose fitting | 4. Barbed-flange fitting (1 inch) |

- Secure the hose fitting and gasket to the adapter (Figure 56) with the flange clamp 51 mm (2 inches).

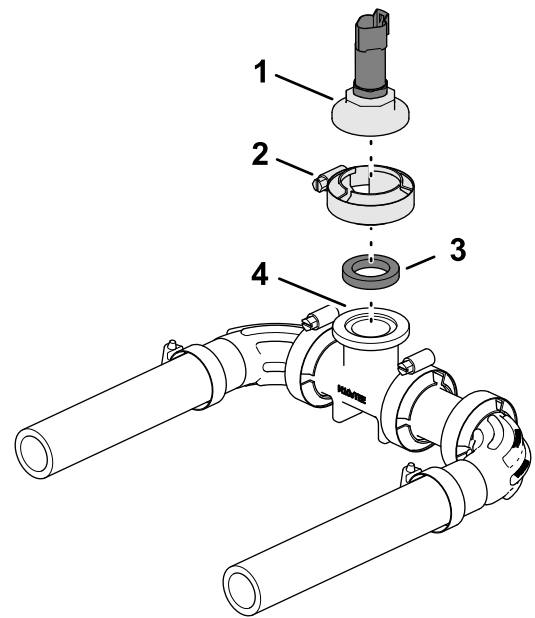

Figure 57

- | | |
|---|-------------------------|
| 1. Pressure transducer and ported-fitting cap | 3. Gasket |
| 2. Flange clamp | 4. T-fitting (manifold) |

- Secure the fitting cap and gasket to the T-fitting with the flange clamp (Figure 57).

Assembling the Pressure Transducer to the Manifold

- Align the ported-fitting cap with pressure transducer and gasket to the T-fitting flange of the manifold (Figure 57).

Installing the Pressure-Transducer Manifold

- Assemble the hose (1 x 7-1/4 inches) onto the barbed elbow fitting of the pressure transducer and manifold as shown in Figure 58.

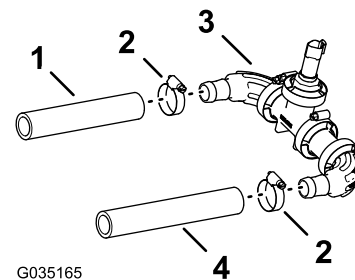

Figure 58

- | | |
|----------------------------|-------------------------------------|
| 1. Hose (1 x 7-1/4 inches) | 3. Pressure transducer and manifold |
| 2. Hose clamp | 4. Hose (1 x 8-1/2 inches) |

- Secure the hose and barbed fittings with a hose clamp (Figure 58).
- Assemble the hose (1 x 8-1/2 inches) onto the other barbed elbow-fitting of the pressure transducer and manifold as shown in Figure 58.
- Secure the hose and barbed fitting with a hose clamp (Figure 58).

Installing the Pressure Transducer onto the Machine

1. Assemble the hose (1 x 7-1/4 inches) that is attached to the pressure transducer and manifold (Figure 59) onto the barbed-flange fitting (1 inch).

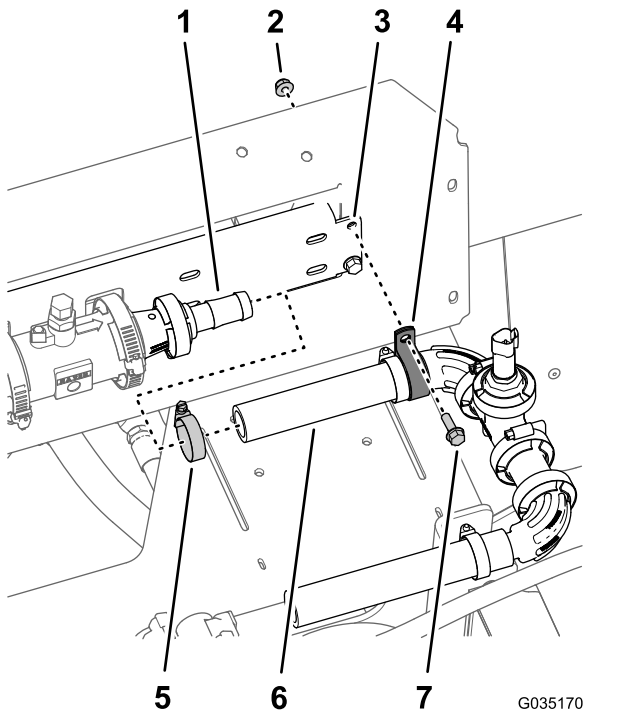

Figure 59

- | | |
|-----------------------------------|--------------------------------------|
| 1. Barbed-flange fitting (1 inch) | 5. Hose clamp |
| 2. Flange locknut (1/4 inch) | 6. Hose (1 x 7-1/4 inches) |
| 3. Slot (Manifold mount) | 7. Flange-head bolt (1/4 x 3/4 inch) |
| 4. R-clamp | |

2. Loosely secure the hose to the barbed-flange fitting with a hose clamp (Figure 59).

Note: You will tighten the hose clamp at the left end of the hose (1 x 7-1/4 inches) in [Assembling the Hose to the Sprayer Valve Manifold](#) (page 30).

3. Secure the pressure transducer and manifold to the slot in the manifold mount with a R-clamp (Figure 59) and the flange-head bolt (1/4 x 3/4 inch), and flange locknut (1/4 inch) that you removed in step 5 of [Disassembling the Boom-Section Valves from the Manifold Mount](#) (page 24).

11

Installing the Valve Mount and Sprayer Valves

Parts needed for this procedure:

1	Valve mount and sprayer-valve assembly
4	Bolt (4 x 10 mm)
1	Sprayer controller
4	Flange locknut (4 mm)
8	Flange-head bolts (5/16 x 3/4 inch)
8	Flange locknuts (5/16 inch)
1	Hose clamp
2	Flange head bolt (1/4 x 3/4 inch)
2	Flange locknut (1/4 inch)

Assembling the Sprayer Controller to the Valve Mount

1. Align the sprayer controller the forward side of the valve mount with the 40-pin connector outward (Figure 60).

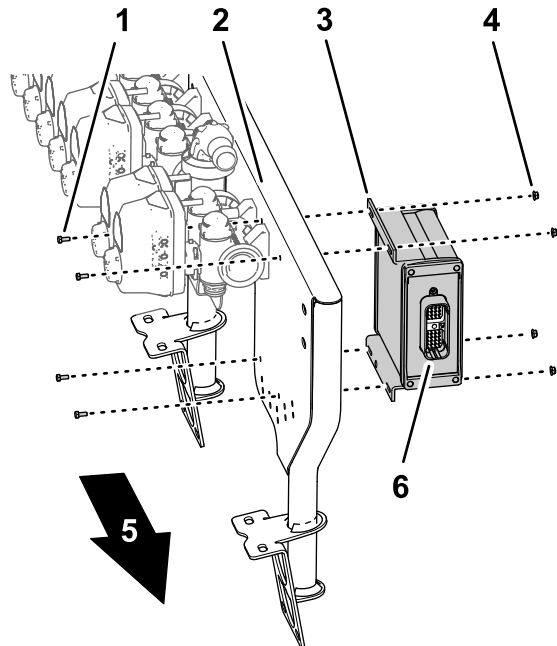

Figure 60

- | | |
|-----------------------|------------------------------|
| 1. Bolt (4 x 10 mm) | 4. Flange locknut (4 mm) |
| 2. 10-valve mount | 5. Right side of the machine |
| 3. Sprayer controller | 6. 40-pin connector |

- Assemble the sprayer controller to the valve mount (Figure 60) with the 4 bolts (4 x 10 mm) and 4 flange locknuts (4 mm).
- Torque the bolts and nuts to 234 to 286 N·cm (21 to 25 to in-lb).

Assembling the Valve Mount and Sprayer Valve Assembly to the Machine

Lifting-equipment capacity: 23 kg (50 lb)

- Using lifting equipment with the specified capacity, lift the valve mount and sprayer valve assembly and align it over the center-boom section (Figure 61).

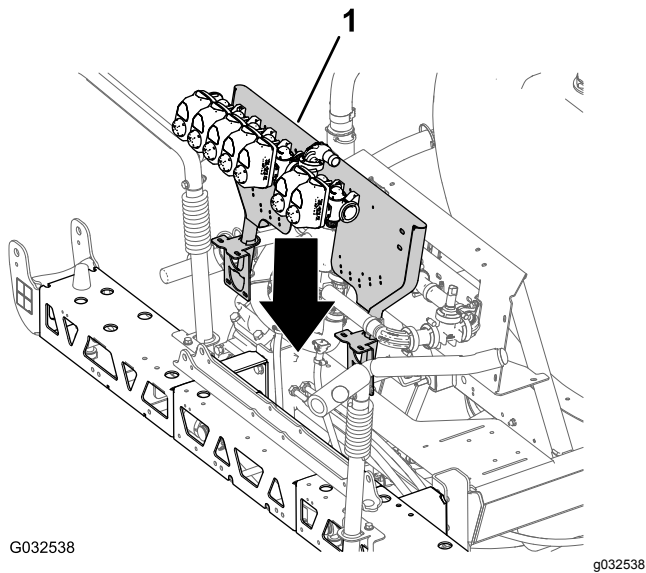

Figure 61

- Valve Mount and Sprayer-Valve Assembly

- Align the holes on the mount bracket of the valve mount to the holes on the truss frame of the center-boom section (Figure 62).

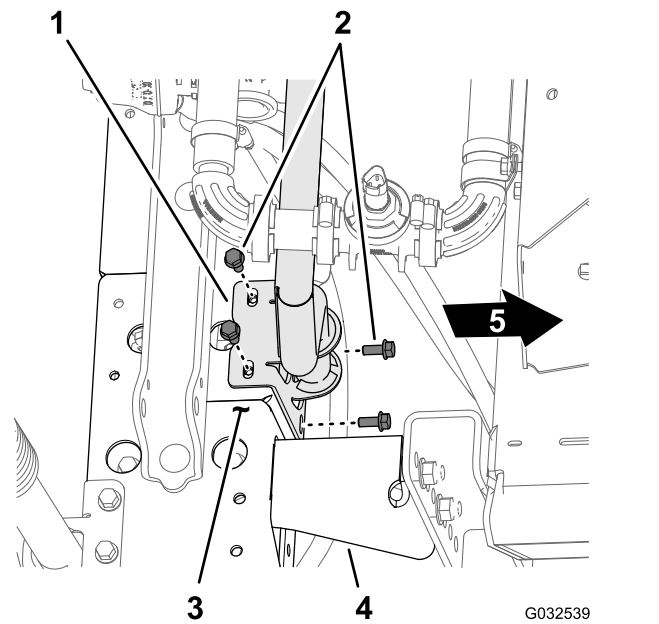

Figure 62

- | | |
|---------------------------------------|-------------------------|
| 1. Mount bracket (valve mount) | 4. Support bracket |
| 2. Flange head bolt (5/16 x 3/4 inch) | 5. Front of the machine |
| 3. Truss frame (center-boom section) | |

- Assemble the valve mount to the truss frame (Figure 62 and Figure 63) with 4 bolts (5/16 x 3/4 inch) and 4 flange locknuts (5/16 inch).

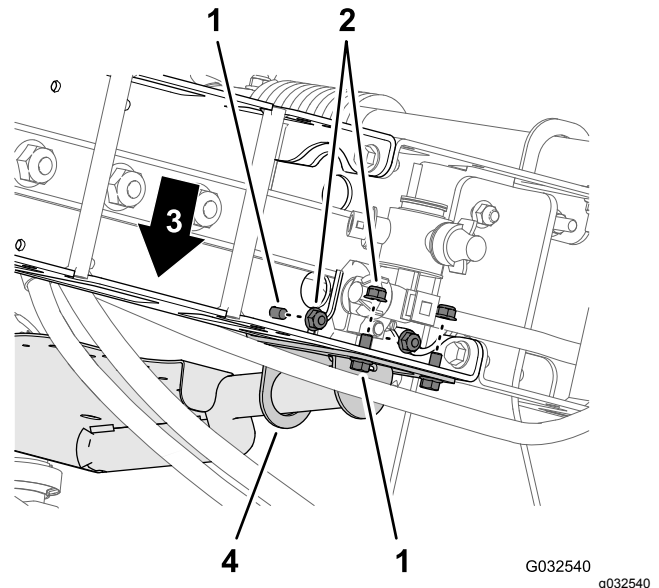

Figure 63

- | | |
|---------------------------------------|--------------------------------|
| 1. Flange head bolt (5/16 x 3/4 inch) | 3. Front of the machine |
| 2. Flange locknuts (5/16 inch) | 4. Mount bracket (valve mount) |

- Repeat steps 2 through 3 for the other mount bracket of the valve mount at the other truss frame.
- Torque the flange-head bolts and flange locknuts to 1978 to 2542 N·cm (175 to 225 in-lb).

Assembling the Hose to the Sprayer Valve Manifold

- Assemble the hose (1 x 8-1/2 inches) over the 90° flange fitting (1 inch) as shown in [Figure 64](#).

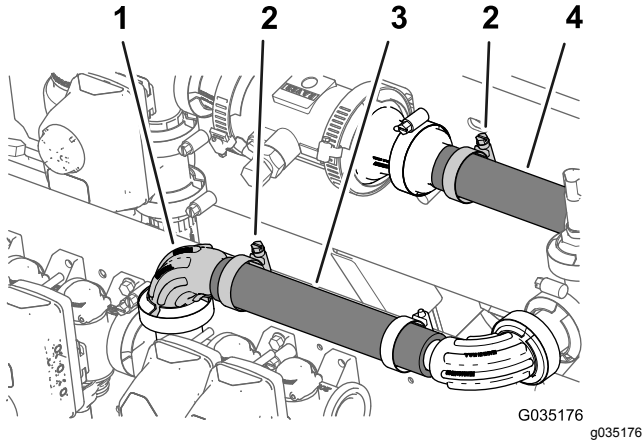

Figure 64

- | | |
|--------------------------------|----------------------------|
| 1. 90° flange fitting (1 inch) | 3. Hose (1 x 8-1/2 inches) |
| 2. Hose clamp | 4. Hose (1 x 7-1/4 inches) |

- Secure the hose to the flange fitting with a hose clamp ([Figure 64](#)).
- Tighten the hose clamp that secures the hose (1 x 7-1/4 inches) to the barbed-flange fitting (1 inch) that you assembled in [Installing the Pressure Transducer onto the Machine \(page 28\)](#); refer to [Figure 64](#).

Assembling Sprayer Valves 8, 9, and 10 to the Valve Mount

Important: The left boom-section valve that you removed in step 3 of [Disassembling the Boom-Section Valves from the Manifold Mount \(page 24\)](#) is identified as nozzle-valve 8, the center boom-section valve is identified as nozzle-valve 9, and the right boom-section valve is identified as nozzle-valve 10 for the remainder of the GeoLink finishing kit installation instructions.

- Align the gasket and the flange of the left section valve (identified as nozzle-valve 8) with the flange of nozzle-valve 7 ([Figure 65](#)).

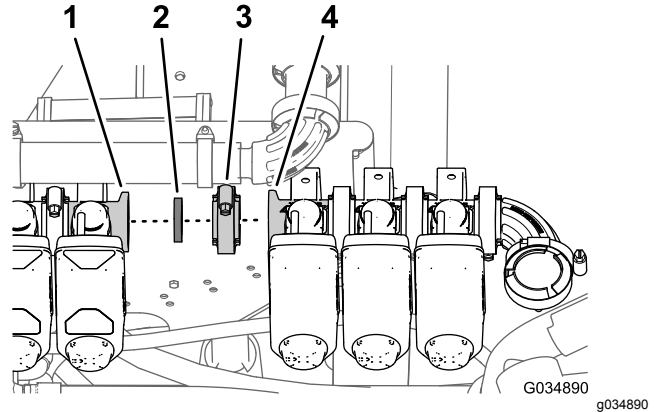

Figure 65

- | | |
|----------------------------|----------------------------|
| 1. Flange (nozzle-valve 7) | 3. Flange clamp |
| 2. Gasket | 4. Flange (nozzle-valve 8) |

- Loosely secure the gasket and nozzle-valve 8 to nozzle valve 7 with a flange clamp ([Figure 65](#)).
- Assemble nozzle-valve 10 to the valve mount ([Figure 66](#)) with the 2 flange-head bolts (1/4 x 3/4 inch) and 2 flange locknuts (1/4 inch) that you removed in step 2 of [Disassembling the Boom-Section Valves from the Manifold Mount \(page 24\)](#).

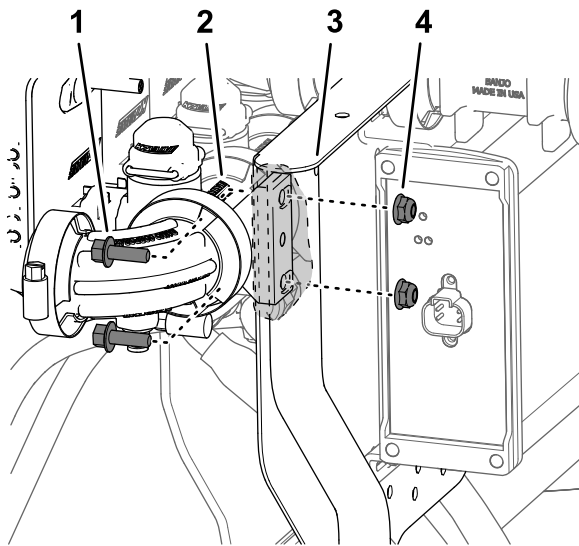
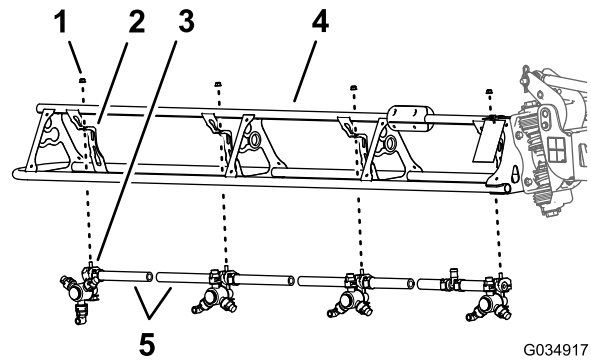

Figure 66

g189520

1. Flange head bolt (1/4 x 3/4 inch)
2. Nozzle-valve 10
3. Valve mount
4. Flange locknut (1/4 inch)

4. Torque the flange-head bolt and locknut to 1017 to 1234 N·cm (90 to 120 in-lb).
5. Tighten the flange clamp by hand.



G034917

g034917

Figure 67

1. Flange locknut (5/16 inch)
2. Nozzle support
3. Sprayer nozzle
4. Outer-boom section
5. Hose (3/4 inch inside diameter)

2. Remove the flange locknut (5/16 inch) that secures the sprayer nozzle to the nozzle support ([Figure 67](#)).
3. Repeat steps [2](#) and [6](#) for the other 3 nozzles.

Note: The hex-head bolt (5/16 x 3/4 inch—stainless steel) will separate from the upper clamp half when you open the clamp, retain the bolt for installation.

Note: Retain the flange locknut and sprayer nozzle for installation in [Installing the Sprayer Nozzles at the Outer-Boom Sections \(page 37\)](#).

Note: You no longer need the hose barbs and cut sections of hose.

4. Repeat steps [2](#) through [3](#) at the other outer-boom section.
5. At the center-boom section, cut the hose between 2 sprayer nozzles ([Figure 67](#)).

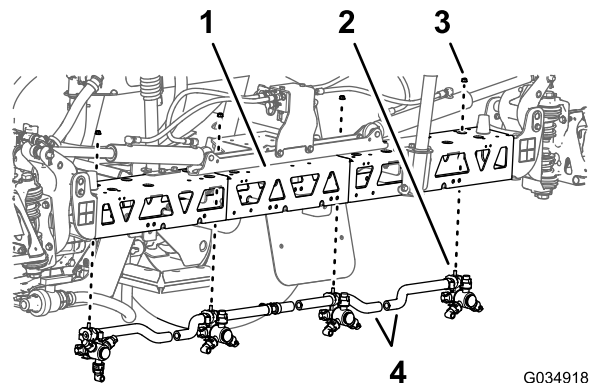

G034918

g034918

Figure 68

1. Center-boom section
2. Sprayer nozzle
3. Flange locknut (5/16 inch)
4. Hose (3/4 inch inside diameter)

12

Removing the Sprayer-Nozzle Hoses for the 3-Section System

No Parts Required

Procedure

1. At the outer-boom section, cut the hose between 2 sprayer nozzles ([Figure 67](#)).

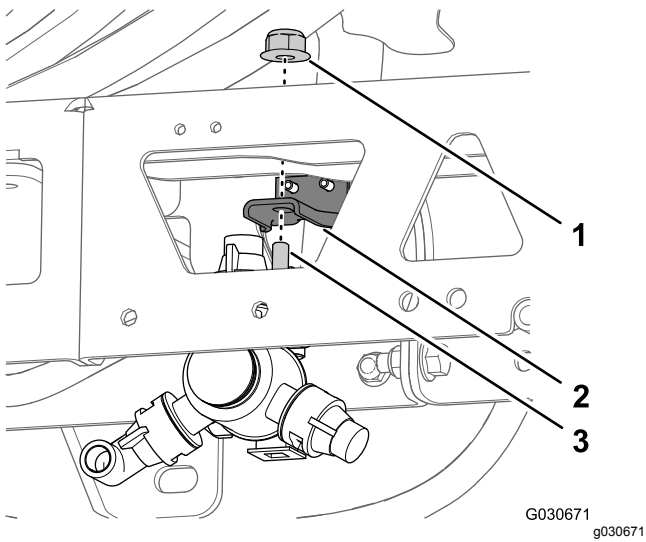

Figure 69

- | | |
|---------------------------|---|
| 1. Flange nut (5/16 inch) | 3. Hex-head bolt (5/16 x 3/4 inch—sprayer nozzle) |
| 2. Nozzle mount | |

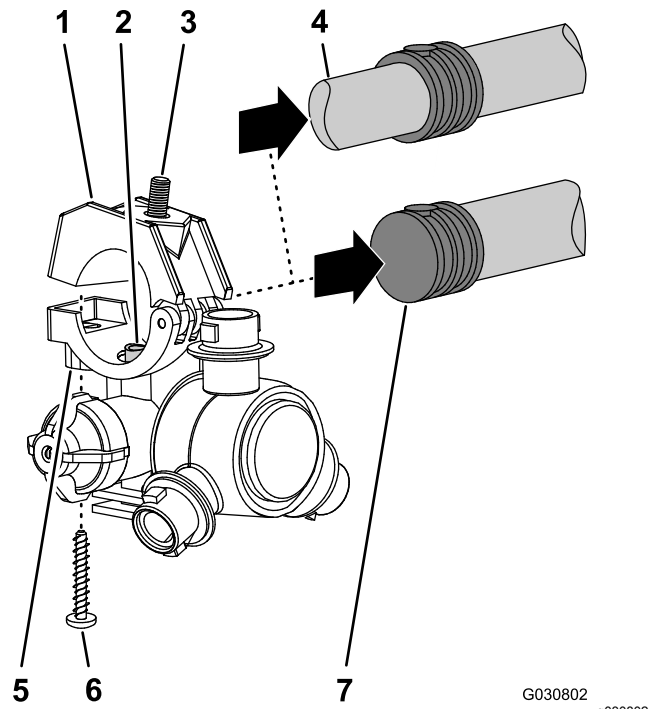

Figure 70

6. Remove the flange locknut (5/16 inch) that secures the sprayer nozzle to the nozzle support (Figure 68).
7. Repeat steps 2 and 6 for the other 3 nozzles.
8. Working with the 12 sprayer nozzles that you removed from the outer- and center-boom sections, remove the stainless steel screws (#12 x 1-1/4 inches) that secures the upper clamp halves and the double or single barbed-hose shanks (3/4 inch) to the body of each of the sprayer nozzle, and remove the barbed-hose shanks (Figure 70).

- | | |
|--|---|
| 1. Upper clamp half | 5. Sprayer-nozzle body |
| 2. Transfer tube | 6. Stainless steel screw (#12 x 1-1/4 inches) |
| 3. Hex-head bolt (5/16 x 3/4 inch—stainless steel) | 7. Single barbed-hose shank (3/4 inch hose) |
| 4. Double barbed-hose shank (3/4 inch hose) | |

Note: The hex-head bolt (5/16 x 3/4 inch—stainless steel) will separate from the upper clamp half when you open the clamp, retain the bolt for installation.

Note: Retain the flange locknut and sprayer nozzle for installation in [Installing the Sprayer Nozzles at the Center-Boom Sections](#) (page 40).

Note: You no longer need the hose barbs and cut sections of hose.

13

Installing the Sprayer-Nozzle Hoses

Parts needed for this procedure:

2	Supply hose 279 cm (110 inches)
2	Supply hose 234 cm (92 inches)
4	Supply hose 188 cm (74 inches)
2	Supply hose 81 cm (32 inches)
2	R-clamp
2	Double R-clamp
2	Single R-clamp

Identifying the Sprayer-Nozzle Hose Positions

Identify the supply hoses by length (Figure 71) for each of the sprayer-nozzle position as follows:

Sprayer nozzle hose-position table

Sprayer-nozzle positions—left-boom section	Sprayer-nozzle positions—center-boom section	Sprayer-nozzle positions—right-boom section
Sprayer nozzle 1 (nozzle valve 1)—supply hose 279 cm (110 inches)	Sprayer nozzles 5 and 6 (nozzle valve 5)—supply hose 81 cm (32 inches) with 2 branch hoses	Sprayer nozzle 9 (nozzle valve 7)—supply hose 188 cm (74 inches)
Sprayer nozzle 2 (nozzle valve 2)—supply hose 234 cm (92 inches)	Sprayer nozzles 7 and 8 (nozzle valve 6)—supply hose 81 cm (32 inches) with 2 branch hoses	Sprayer nozzle 10 (nozzle valve 8)—supply hose 188 cm (74 inches)
Sprayer nozzle 3 (nozzle valve 3)—supply hose 188 cm (74 inches)		Sprayer nozzle 11 (nozzle valve 9)—supply hose 234 cm (92 inches)
Sprayer nozzle 4 (nozzle valve 4)—supply hose 188 cm (74 inches)		Sprayer nozzle 12 (nozzle valve 10)—supply hose 279 cm (110 inches)

Note: Refer to Figure 72 in *Assembling the Hoses to Nozzle Valves 1 through 4* (page 35), Figure 73 in *Assembling the Hoses to Nozzle Valves 5 and 6* (page 35), and Figure 74 in *Assembling the Hoses to Nozzle Valves 7 through 10* (page 36) for the nozzle-valve positions.

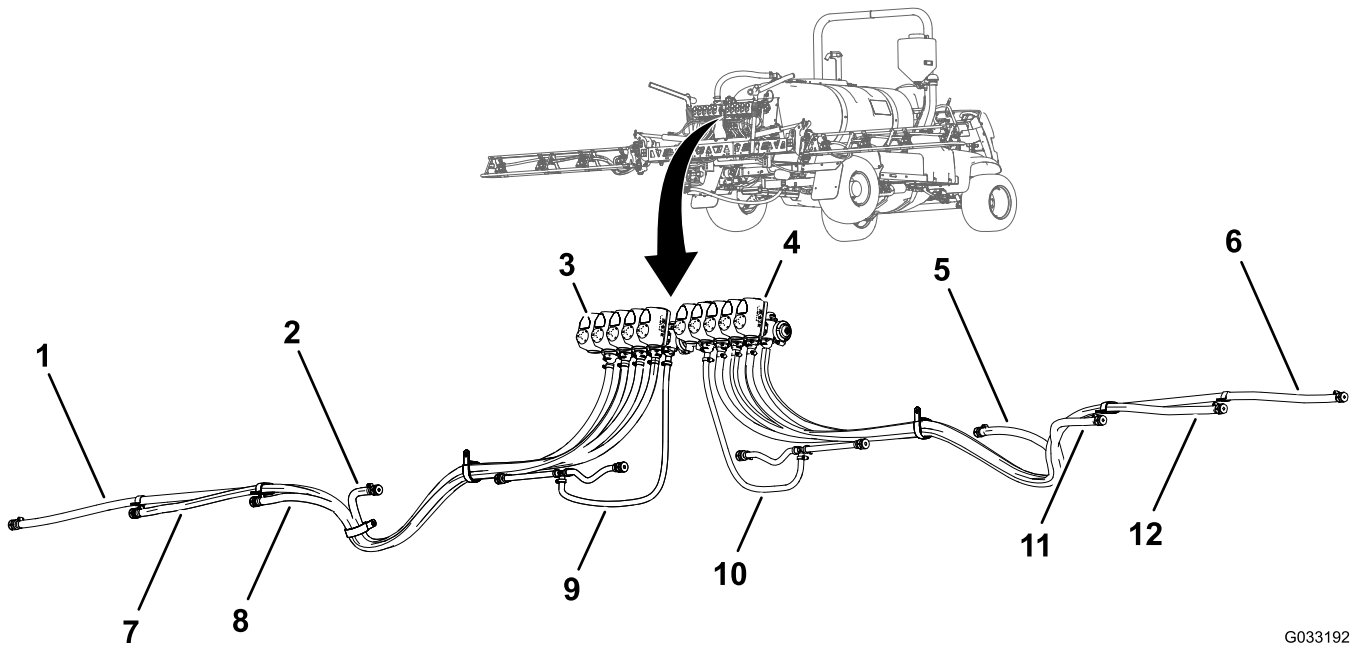

G033192
g033192

Figure 71

- | | | |
|---|--|--|
| 1. Supply hose 279 cm (110 inches)—sprayer nozzle 1 | 5. Supply hose 188 cm (74 inches)—sprayer nozzle 9 | 9. Supply hose 81 cm (32 inches)—sprayer nozzle 5 and 6 |
| 2. Supply hose 188 cm (74 inches)—sprayer nozzle 4 | 6. Supply hose 279 cm (110 inches)—sprayer nozzle 12 | 10. Supply hose 81 cm (32 inches)—sprayer nozzle 7 and 8 |
| 3. Nozzle valve 1 | 7. Supply hose 234 cm (92 inches)—sprayer nozzle 2 | 11. Supply hose 188 cm (74 inches)—sprayer nozzle 10 |
| 4. Nozzle valve 10 | 8. Supply hose 188 cm (74 inches)—sprayer nozzle 3 | 12. Supply hose 234 cm (92 inches)—sprayer nozzle 11 |

Assembling the Hoses to Nozzle Valves 1 through 4

1. Assemble the straight barbed fitting of a supply hose 279 cm (110 inches) onto the coupler of nozzle valve 1 (Figure 72).

Note: Ensure that the barbed fitting is fully seated onto the coupler.

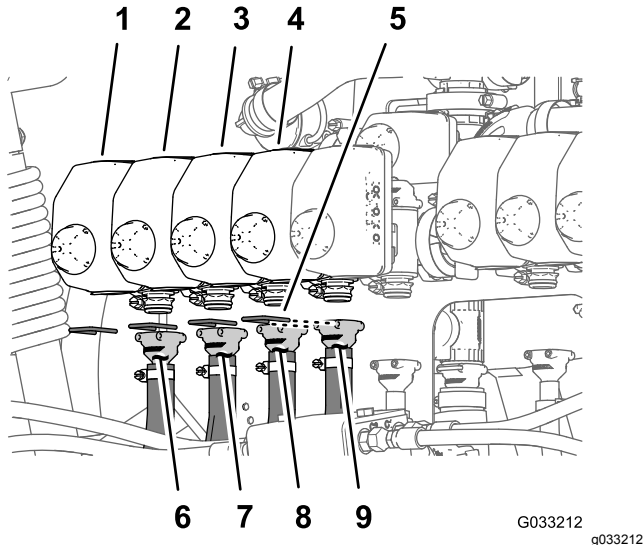

Figure 72

- | | |
|-------------------|------------------------------------|
| 1. Nozzle valve 1 | 6. Supply hose 279 cm (110 inches) |
| 2. Nozzle valve 2 | 7. Supply hose 234 cm (92 inches) |
| 3. Nozzle valve 3 | 8. Supply hose 188 cm (74 inches) |
| 4. Nozzle valve 4 | 9. Supply hose 188 cm (74 inches) |
| 5. Retainer | |

2. Secure the barbed fitting to the coupler with a retainer (Figure 72).
3. Assemble the straight barbed fitting of a supply hose 234 cm (92 inches) onto the coupler of nozzle valve 2 (Figure 72).

Note: Ensure that the barbed fitting is fully seated onto the coupler.

4. Secure the barbed fitting to the coupler with a retainer (Figure 72).
5. Assemble the straight barbed fitting of a supply hose 188 cm (74 inches) onto the coupler of nozzle valve 3 (Figure 72).

Note: Ensure that the barbed fitting is fully seated onto the coupler.

6. Secure the barbed fitting to the coupler with a retainer (Figure 72).

7. Assemble the straight barbed fitting of a supply hose 188 cm (74 inches) onto the coupler of nozzle valve 4 (Figure 72).

Note: Ensure that the barbed fitting is fully seated onto the coupler.

8. Secure the barbed fitting to the coupler with a retainer (Figure 72).

Assembling the Hoses to Nozzle Valves 5 and 6

Note: Supply hose assembly 81 cm (32 inches) has a T-fitting with 2 branch hoses and 2 single barbed-hose shanks.

1. Assemble the straight barbed fitting of a supply hose 81 cm (32 inches) onto the coupler of nozzle valve 5 (Figure 73).

Note: Ensure that the barbed fitting is fully seated onto the coupler.

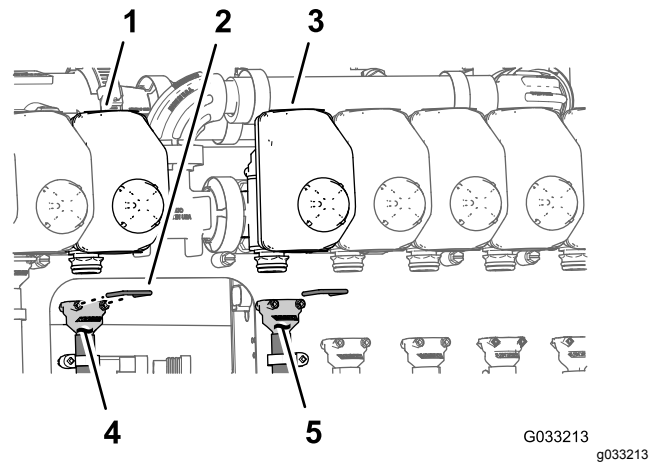

Figure 73

- | | |
|-------------------|----------------------------------|
| 1. Nozzle valve 5 | 4. Supply hose 81 cm (32 inches) |
| 2. Retainer | 5. Supply hose 81 cm (32 inches) |
| 3. Nozzle valve 6 | |

2. Secure the barbed fitting to the coupler with a retainer (Figure 73).
3. Assemble the straight barbed fitting of a supply hose 81 cm (32 inches) onto the coupler of nozzle valve 6 (Figure 73).

Note: Ensure that the barbed fitting is fully seated onto the coupler.

4. Secure the barbed fitting to the coupler with a retainer (Figure 73).

Assembling the Hoses to Nozzle Valves 7 through 10

1. Assemble the straight barbed fitting of a supply hose 188 cm (74 inches) onto the coupler of nozzle valve 7 (Figure 74).

Note: Ensure that the barbed fitting is fully seated onto the coupler.

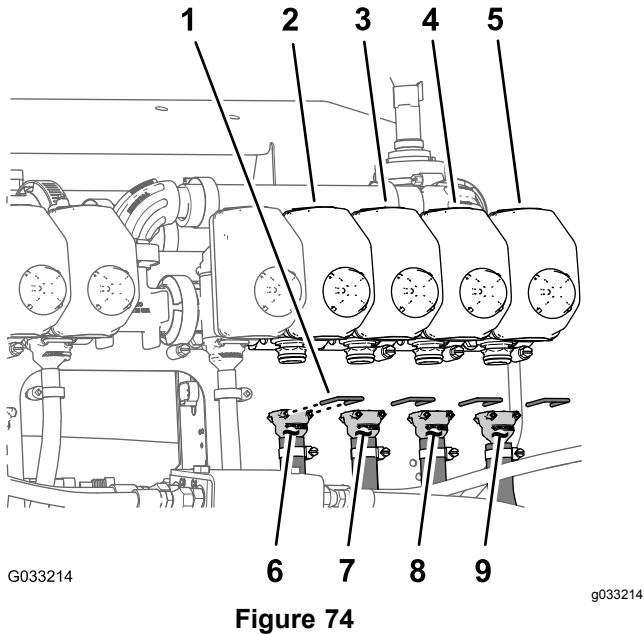

Figure 74

2. Secure the barbed fitting to the coupler with a retainer (Figure 74).
3. Assemble the straight barbed fitting of a supply hose 188 cm (74 inches) onto the coupler of nozzle valve 8 (Figure 74).

Note: Ensure that the barbed fitting is fully seated onto the coupler.

4. Secure the barbed fitting to the coupler with a retainer (Figure 74).
5. Assemble the straight barbed fitting of a supply hose 234 cm (92 inches) onto the coupler of nozzle valve 9 (Figure 74).

Note: Ensure that the barbed fitting is fully seated onto the coupler.

6. Secure the barbed fitting to the coupler with a retainer (Figure 74).
7. Assemble the straight barbed fitting of a supply hose 279 cm (110 inches) onto the coupler of nozzle valve 10 (Figure 74).

Note: Ensure that the barbed fitting is fully seated onto the coupler.

8. Secure the barbed fitting to the coupler with a retainer (Figure 74).

Routing the Supply Hoses at the Outer-Boom Sections

1. Route the hoses for sprayer nozzles 1, 2, 3, and 4 through the R-clamp at the left outboard end of the center-boom section (Figure 75 and Figure 76).

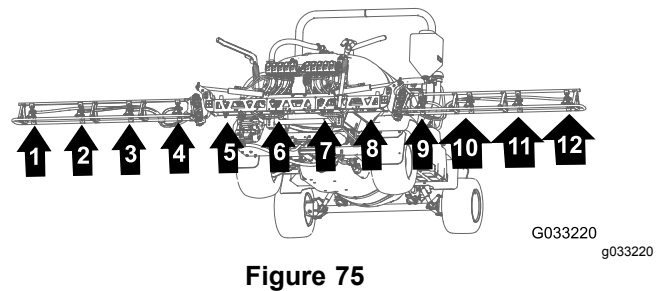

Figure 75

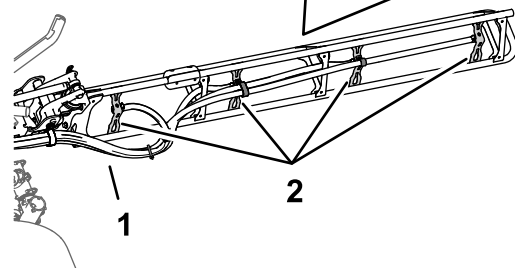
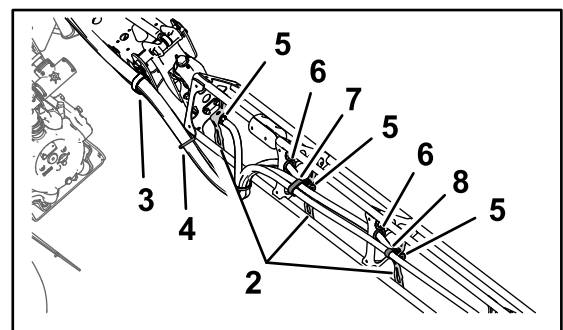

Figure 76

- | | |
|--------------------|--|
| 1. Hoses | 5. Single barbed-hose shank (1/2 inch) |
| 2. Nozzle supports | 6. Grommet |
| 3. R-clamp | 7. Double R-clamp |
| 4. Cable tie | 8. Single R-clamp |

2. Route the hoses for sprayer nozzles 7, 8, 9, and 10 through the R-clamp at the right outboard end of the center-boom section (Figure 75 and Figure 76).
3. Route the supply hoses 279 cm (110 inches) and barbed-hose shanks (3/4 inch) along the boom section to sprayer nozzles 1 and 10 as shown in (Figure 75 and Figure 76).
4. Route the supply hoses 234 cm (92 inches) and barbed-hose shanks (3/4 inch) along the boom section to sprayer nozzles 2 and 9 along the

boom section as shown in [Figure 75](#) and [Figure 76](#).

5. Route the supply hoses 188 cm (74 inches) and barbed-hose shanks (3/4 inch) along the boom section to sprayer nozzles 3 and 8 as shown in [Figure 75](#) and [Figure 76](#).

Note: Route the hoses through the lower rear grommets in the tube-frame brackets.

6. Route the supply hoses 188 cm (74 inches) and barbed-hose shanks (3/4 inch) along the boom section to sprayer nozzles 4 and 7 as shown in [Figure 75](#) and [Figure 76](#).

Note: Route the hoses through the lower rear grommets in the tube-frame brackets.

7. Bundle the 4 hoses for the sprayer nozzles together with a cable tie as shown in [Figure 76](#).

Installing the Sprayer Nozzles at the Outer-Boom Sections

1. Working with the sprayer nozzle that you removed in [12 Removing the Sprayer-Nozzle Hoses for the 3-Section System](#) (page 31), align the transfer tube in the saddle of a sprayer nozzle ([Figure 77](#)) with the hole in the side of the single barbed-hose shank (1/2 inch).

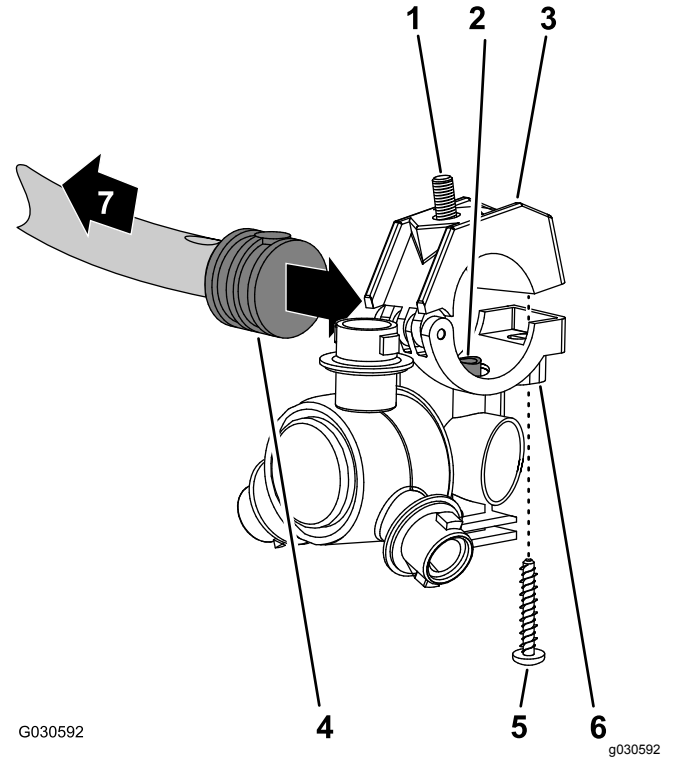

Figure 77

- | | |
|--|---|
| 1. Hex-head bolt (5/16 x 3/4 inch—stainless steel) | 5. Stainless steel screw (#12 x 1-1/4 inches) |
| 2. Transfer tube | 6. Sprayer-nozzle body |
| 3. Upper clamp half | 7. Toward the boom section |
| 4. Single barbed-hose shank (1/2 inch) | |

2. Close the upper clamp half around the barbed-hose shank and secure the clamp half and spray-nozzle body ([Figure 77](#)) with the stainless steel screw (#12 x 1-1/4 inches); torque the stainless steel screw to 226 to 282 N·cm (20 to 25 in-lb).

Note: Ensure that the hex-head bolt (5/16 x 3/4 inch) is seated in the recess in the upper clamp half when closing the clamp.

3. Assemble the sprayer nozzles to the outer-boom section as follows:
 - At the nozzle positions 1 and 4, assemble the sprayer nozzle to the nozzle mount (A of [Figure 78](#)) with the flange locknut (5/16 inch) that you removed in step 2 of [12 Removing](#)

the Sprayer-Nozzle Hoses for the 3-Section System (page 31).

- At the nozzle positions 2 and 3, assemble the sprayer nozzle to the nozzle mount (A and B of Figure 78) with the flange locknut (5/16 inch) that you removed in step 2 of 12 Removing the Sprayer-Nozzle Hoses for the 3-Section System (page 31).

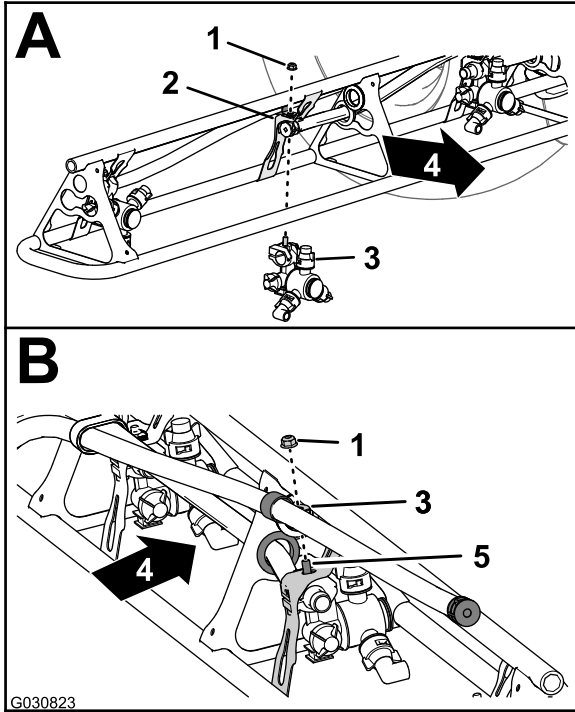

Figure 78

- | | |
|-------------------------------|--|
| 1. Flange locknut (5/16 inch) | 4. Back of the machine |
| 2. Nozzle mount | 5. Hex-head bolt (stainless steel—5/16 x 3/4 inch) |
| 3. Sprayer nozzle | |

- Torque the flange locknut to 1,978 to 2,542 N·cm (175 to 225 in·lb).
- Repeat steps 1 through 4 for the other sprayer nozzles for the boom section.
- Repeat steps 1 through 5 to the outer-boom section at the other side of the machine.

Routing the Supply Hoses at the Center-Boom Section

- Ensure that the hoses and barbed couplers 13 x 810 mm (1/2 x 32 inches) are aligned to the front of the center-boom section between the left and right support brackets for the center section.
- Route the hose 13 mm (10 inches) and barbed-hose shank between the truss braces of the outer truss (Figure 79).

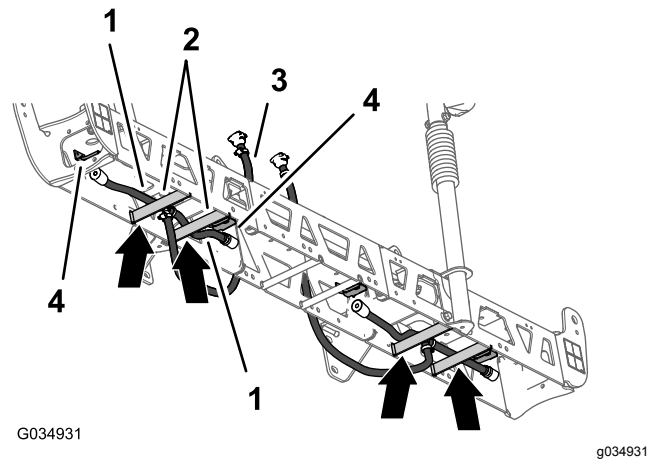

G034931

g034931

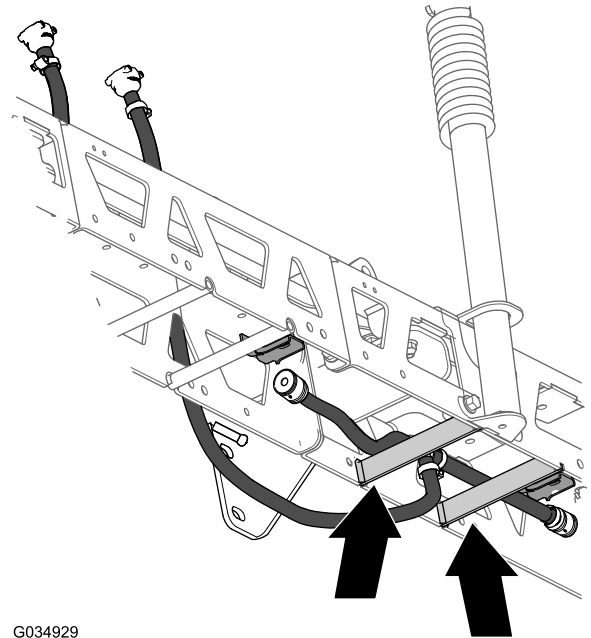

G034929

g034929

Figure 79

- | | |
|--|---|
| 1. Hoses 13 x 250 mm (1/2 x 10 inches) | 3. Hose and barbed-hose shank 13 x 810 mm (1/2 x 32 inches) |
| 2. Truss braces (left truss) | 4. Sprayer-nozzle mounts |

- Route the hose and barbed-hose shank above the truss brace and outward to the outboard nozzle mount (Figure 79).
- Route the other hose 13 mm (10 inches) and barbed-hose shank between the truss braces of the inner truss (Figure 79).
- Route the hose and barbed-hose shank above the truss brace and inward to the inboard nozzle mount (Figure 79).
- Repeat steps 2 through 7 for the other hose and nozzle assembly at the other outer truss (Figure 79 and Figure 82).
- Route the hose and barbed coupler 13 x 810 mm (1/2 x 32 inches) to the side of the center-boom

section with the left and right support brackets for the boom section (Figure 79).

Assembling the Sprayer Nozzles and Hoses for the Center-Boom Section

1. Working with the sprayer nozzles that you removed in [12 Removing the Sprayer-Nozzle Hoses for the 3-Section System](#) (page 31), remove the stainless steel screws that secure the upper clamp halves to the saddles (Figure 80).

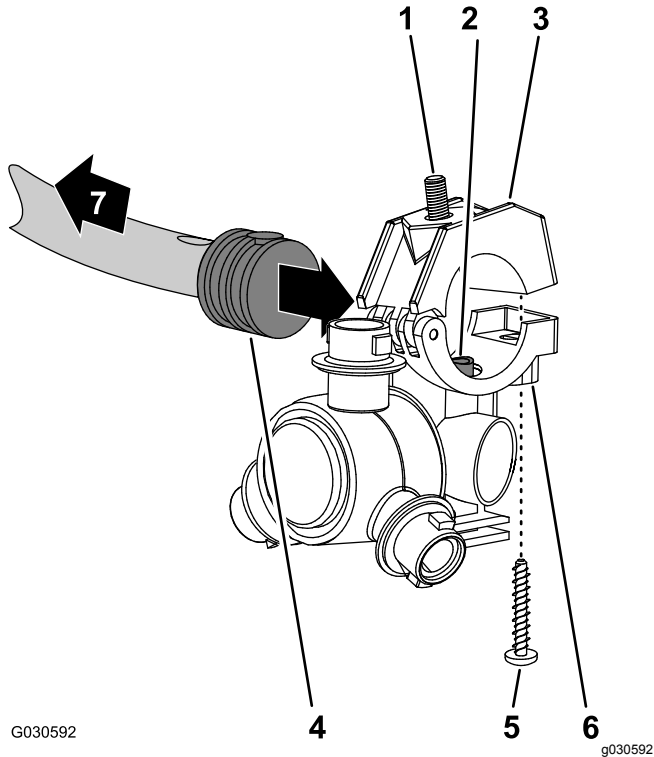

Figure 80

- | | |
|--|---|
| 1. Hex-head bolt (5/16 x 3/4 inch—stainless steel) | 5. Stainless steel screw (#12 x 1-1/4 inches) |
| 2. Transfer tube | 6. Sprayer-nozzle body |
| 3. Upper clamp half | 7. Toward the boom section |
| 4. Single barbed-hose shank (1/2 inch) | |

2. Locate the hole in the side of single barbed-hose shank at the end of the hose 25 cm (10 inches) of the hose assembly (sprayer valve 5 or 6) for the center-boom section (Figure 80 and Figure 81).

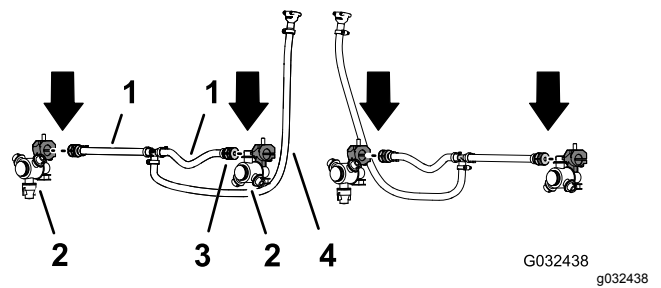

Figure 81

- | | |
|--|---|
| 1. Hose 13 x 250 mm (1/2 x 10 inches—sprayer valve 5 or 6) | 3. Single barbed-hose shank 13 mm (1/2 inch) |
| 2. Sprayer nozzle | 4. Hose and barbed coupler 13 x 810 mm (1/2 x 32 inches—sprayer valve 5 or 6) |

3. Align the transfer tube in the saddle of a sprayer nozzle (Figure 80) with the hole in the side of the single barbed-hose shank (1/2 inch).
4. Close the upper clamp half around the barbed-hose shank and sprayer-nozzle body (Figure 80) with the stainless steel screw (#12 x 1-1/4 inches); torque the stainless steel screw to 226 to 282 N·cm (20 to 25 in-lb).

Important: Do not tighten the stainless steel screw more than the torque specification in step 4.

Note: Ensure that the hex-head bolt (5/16 x 3/4 inch) is seated in the recess in the upper clamp half when closing the clamp.

5. Repeat steps 2 through 4 to the single barbed-hose shanks of the other hose assemblies (sprayer valve 5 or 6) for the center-boom section (Figure 80 and Figure 81).

Installing the Sprayer Nozzles at the Center-Boom Sections

1. Align the hex-head bolt (5/16 x 3/4 inch) of the sprayer nozzle through the hole in the nozzle mount (Figure 82) and loosely secure the nozzle to the mount with a flange locknut (5/16 inch) that you removed in steps 1 or 4 of 12 Removing the Sprayer-Nozzle Hoses for the 3-Section System (page 31).

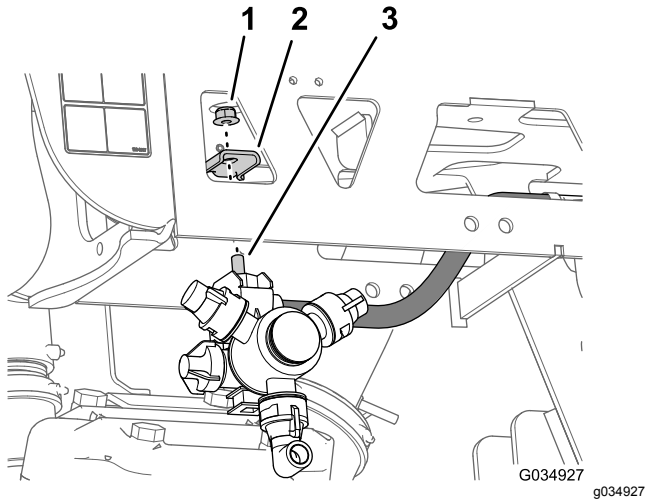

Figure 82

1. Flange locknut (5/16 inch)
 2. Nozzle mount (outboard)
 3. Hex-head bolt (5/16 x 3/4 inch—stainless steel)
-
2. Repeat step 1 for the 3 other sprayer nozzles for the center-boom section.
 3. Torque the flange locknuts to 1978 to 2542 N·cm (175 to 225 in·lb).

14

Assembling the Rear Wiring Harness to the Machine

Parts needed for this procedure:

1	Rear wire harness
3	Cable tie

Routing Wire Harness Along the Frame Tube

1. Locate the 165 cm (65 inch) branch and the 203 cm (80 inch) branch of the new electrical harness (Figure 83).

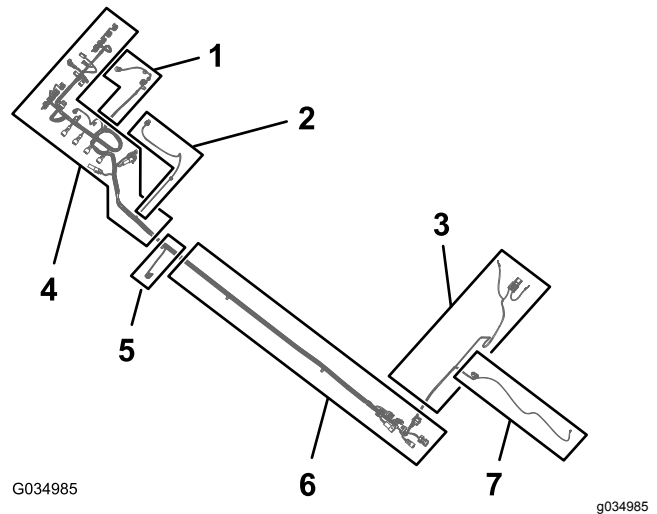

Figure 83

- | | |
|--|--|
| 1. 81 cm (32 inch) wire-harness branch— flow meter and agitation valve | 5. 33 cm(13 inch) wire-harness branch—speed sensor |
| 2. 86 cm (34 inch) wire-harness branch— spray-pump solenoid | 6. 170 cm (67 inch) wire-harness branch—front harness interface connectors |
| 3. 165 cm (65 inch) wire-harness branch—ring terminals and fuse (unmarked) | 7. 81 cm (32 inch) wire-harness branch—sprayer pump shutoff circuit |
| 4. 203 cm (80 inch) wire-harness branch— ASC10 , lift cylinder solenoids, nozzle-valves 1 through 10 | |

2. Route the 165 cm (65 inch) branch and the 203 cm (80 inch) branch of the new electrical harness between the valve mount for the 10

sprayer valves and right support for the manifold mount (Figure 84).

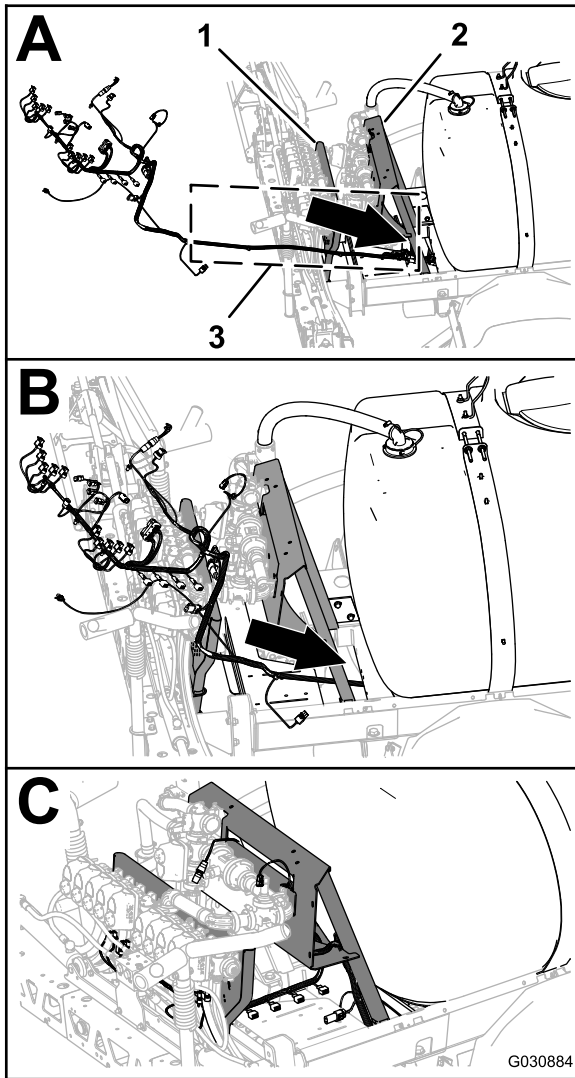

Figure 84

1. Valve mount (10 sprayer valves)
2. Manifold mount
3. 165 cm (65 inch) and 203 cm (80 inch) branches (electrical harness)

3. Route the 165 cm (65 inch) branch and the 203 cm (80 inch) branch of the electrical harness forward along the right frame tube (Figure 85).

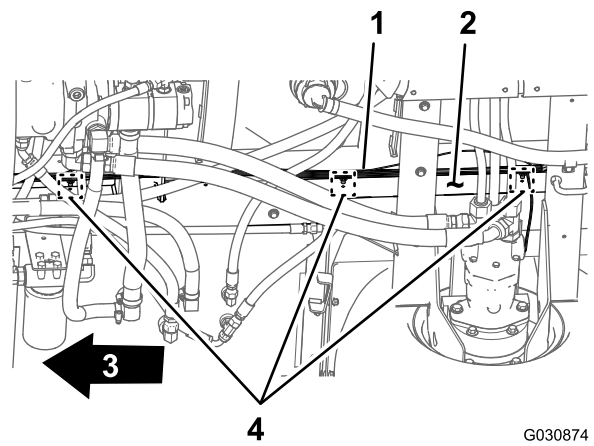

Figure 85

1. Rear wire harness—203 cm (80 inch) branch
2. Right frame tube
3. Front of the machine
4. Push-in fasteners and cable tie locations

4. Insert the push-in fasteners of the 203 cm (80 inch) branch of the rear wire harness into the holes in the right frame tube (Figure 85) where the push-in fasteners of the old rear harness were removed; refer to step 3 in [Disconnecting the Front and Rear Wire Harnesses](#) (page 13).

Connecting the Front and Rear Wire Harnesses

Note: Use a machine hoist when connecting the front and rear wire harnesses.

1. From under the machine along the right frame tube, locate the electrical connectors for the front and rear wire harnesses of the machine (Figure 86).

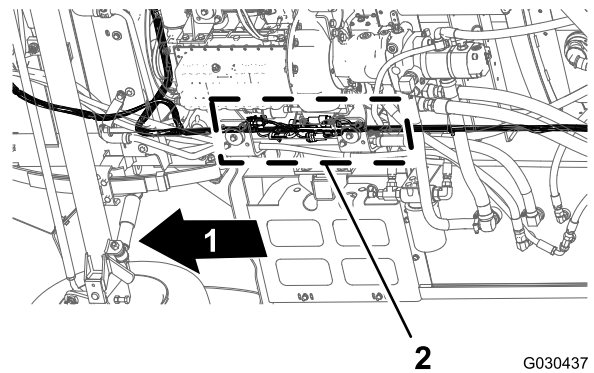

Figure 86

1. Front of the machine
2. Connector interfaces (front and rear wire harnesses)

2. Connect the 10-socket connector of the front harness for the sprayer-harness interconnect into the 10-pin connector of the rear harness for the sprayer-harness interconnect (Figure 87).

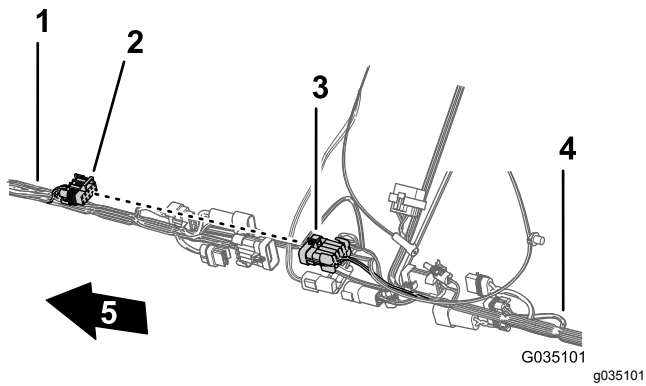

Figure 87

- | | |
|---|-------------------------|
| 1. Front wire harness | 4. Rear wire harness |
| 2. 10-socket connector—sprayer-harness interconnect (front harness) | 5. Front of the machine |
| 3. 10-pin connector—sprayer-harness interconnect (rear harness) | |

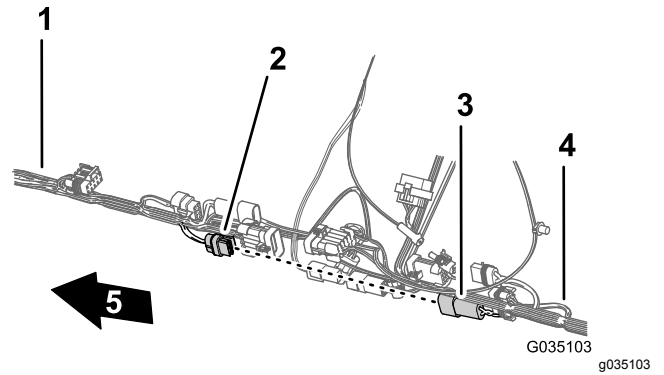

Figure 89

- | | |
|---|-------------------------|
| 1. Front wire harness | 4. Rear wire harness |
| 2. 2-socket connector—rinse pump (rear harness) | 5. Front of the machine |
| 3. 2-pin connector—rinse pump (front harness) | |

3. Connect the 8-pin connector of the front harness for the sprayer-harness interconnect into the 8-socket connector of the rear harness for the rate switch (Figure 88).

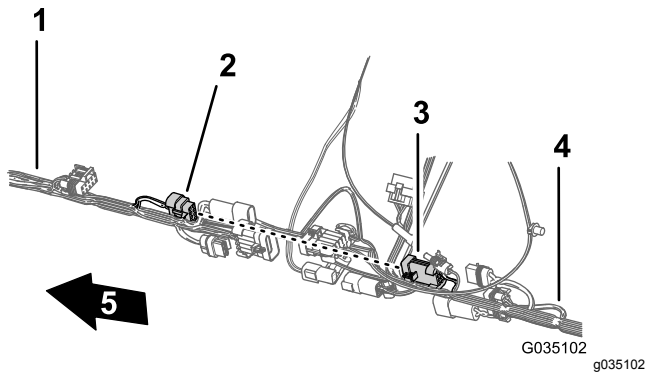

Figure 88

- | | |
|---|-------------------------|
| 1. Front wire harness | 4. Rear wire harness |
| 2. 8-pin connector—sprayer-harness interconnect (front harness) | 5. Front of the machine |
| 3. 8-socket connector—rate switch (rear harness) | |

5. Connect the 2-pin connector of the front harness for the hose-reel power into the 2-socket connector of the rear harness for the hose-reel power (Figure 90).

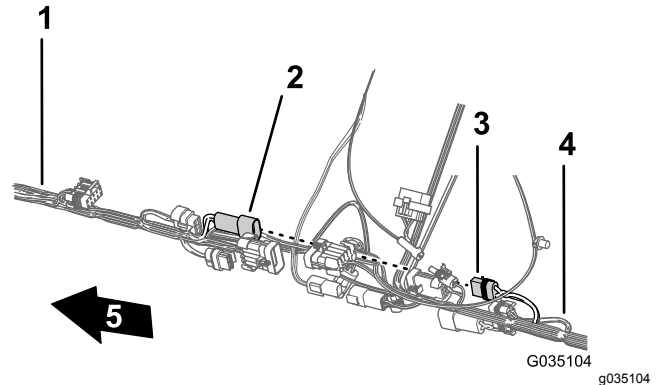

Figure 90

- | | |
|--|-------------------------|
| 1. Front wire harness | 4. Rear wire harness |
| 2. 2-pin connector—hose reel (front harness) | 5. Front of the machine |
| 3. 2-socket connector—hose reel (rear harness) | |

4. Connect the 2-pin connector of the front harness for the rinse pump into the 2-socket connector of the rear harness for the rinse pump (Figure 89).

6. Connect the 10-pin connector of the front harness for the sprayer-harness interconnect into the 10-socket connector of the rear harness for the sprayer-harness interconnect (Figure 91).

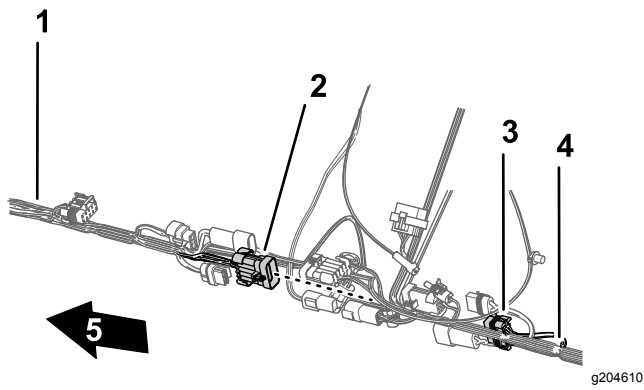

Figure 91

- | | |
|--|-------------------------|
| 1. Front wire harness | 4. Rear wire harness |
| 2. 10-pin connector—sprayer-harness interconnect (front harness) | 5. Front of the machine |
| 3. 10-socket connector—sprayer-harness interconnect (rear harness) | |

7. To ease connecting the navigation-electrical and data harnesses, ensure that the 1-socket connector of the rear-wire harness and the 4-socket connector of the rear-wire harness are aligned to the top of the harness (Figure 92).

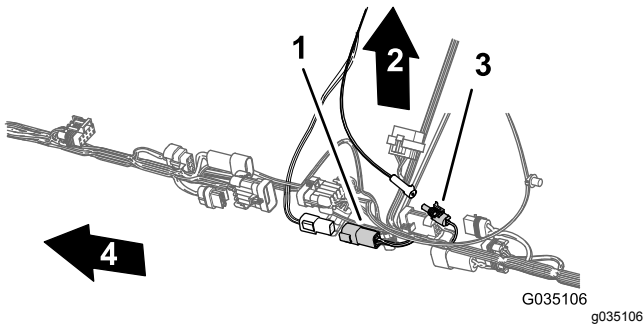

Figure 92

- | | |
|---|---|
| 1. 4-socket connector (rear-wire harness) | 3. 1-socket connector (rear-wire harness) |
| 2. Top of the machine | 4. Front of the machine |

8. Secure the pump-interrupt relay of the rear-wire harness to the right support for the seat-support angle (Figure 93).

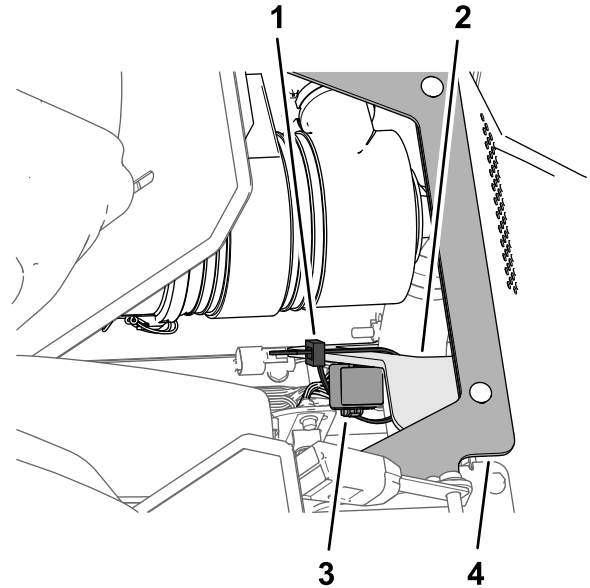
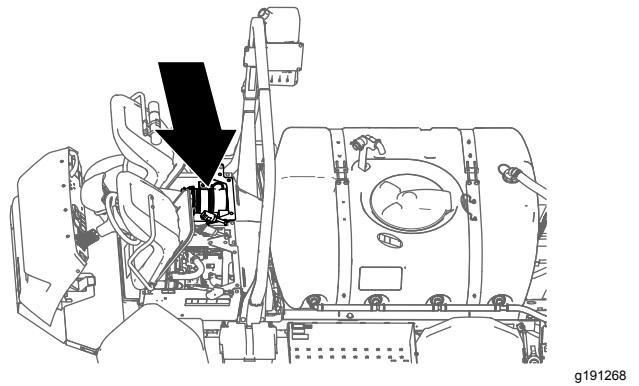

Figure 93

- | | |
|------------------|-------------------------|
| 1. Cable tie | 3. Pump-interrupt relay |
| 2. Right support | 4. Seat-support angle |

Routing the Pressure-Sense Tube for the Dash Gauge along the Rear Wire Harness

1. Route the pressure-sense tube for the dash gauge along the rear wire harness of the machine (Figure 94).

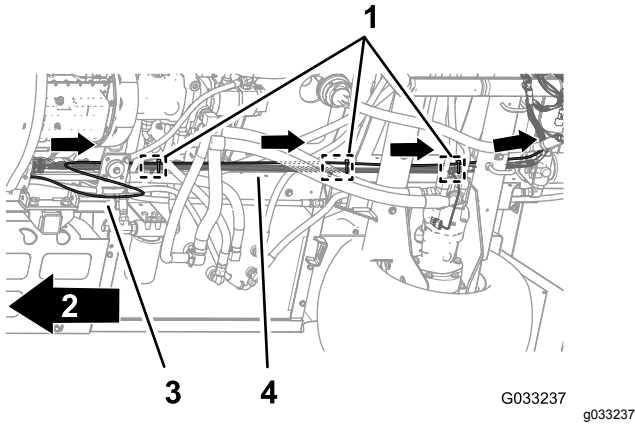

Figure 94

- | | |
|---|------------------------|
| 1. Cable ties (3 push-in fasteners—chassis anchor points) | 3. Pressure-sense tube |
| 2. Front of the machine | 4. Rear wire harness |

2. Secure the pressure-sense tube to the rear wire harness with 3 cable ties adjacent to the 3 push-in fasteners at the chassis anchor points for the rear wire harness (Figure 94).

Important: Do not pinch or collapse the pressure-sense tube; tighten the cable ties only enough to support the tube.

15

Installing the Engine-Control Module and Mounting Bracket (Machine Models with a Gasoline Engine)

No Parts Required

Procedure

1. Align the holes in the mounting bracket for the engine-control module with the hole in the support bracket of the engine and accessory case of the engine (Figure 95).

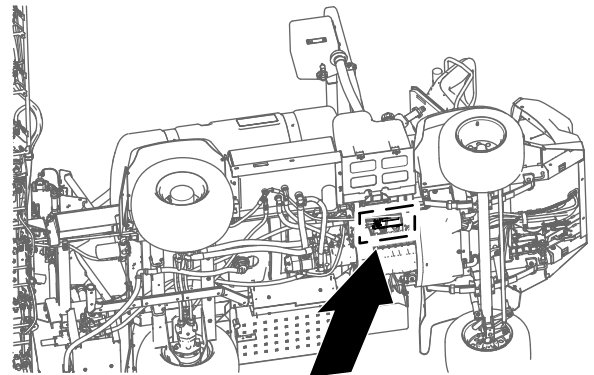

g189642

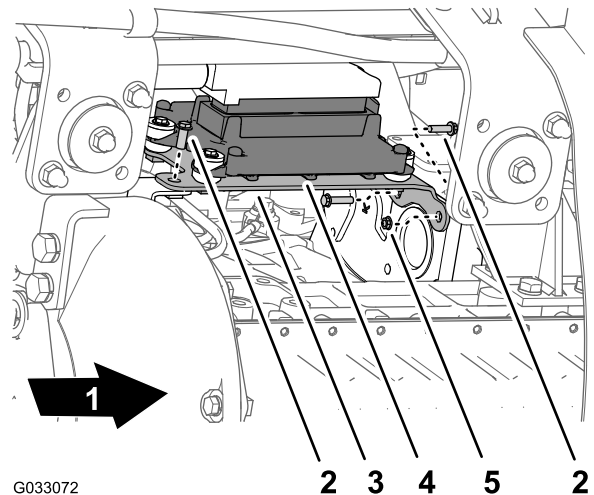

G033072

g033072

Figure 95

- | | |
|-------------------------|--------------------------|
| 1. Front of the machine | 4. Engine-control module |
| 2. Flange-head bolt | 5. Flange nut |
| 3. Mounting bracket | |

- Assemble the mounting bracket to the engine with the 3 flange head bolts and 1 flange nut that you removed in step 1 of 5 [Removing the Engine-Control Module and Mounting Bracket \(Machine Models with a Gasoline Engine\)](#) (page 11); tighten the bolts and nuts by hand.

- Assemble the undercarriage shroud to the engine-mount brackets and bolts ([Figure 96](#)) with the 4 flange locknuts (5/16 inch) that you removed in step 2 of 4 [Removing the Undercarriage Shroud](#) (page 9).
- Align the holes in the rear part of the undercarriage shroud with the holes in the chassis ([Figure 97](#)).

16

Installing the Undercarriage Shroud

No Parts Required

Procedure

- Align the undercarriage shroud to the bottom chassis of the machine ([Figure 96](#)).

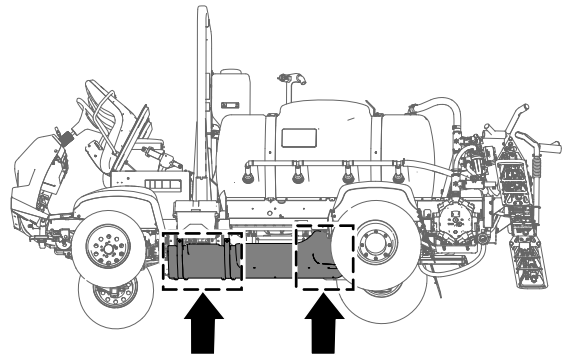

g189584

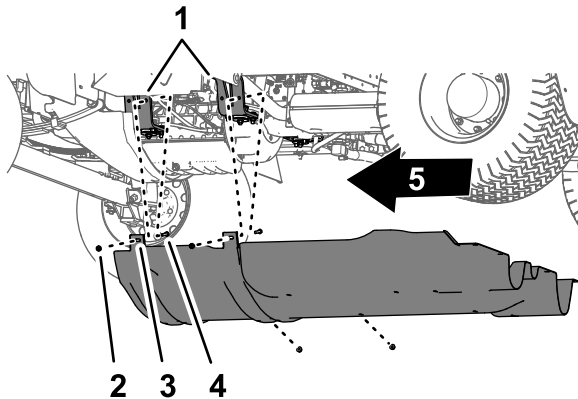

g189583

Figure 96

- | | |
|---------------------------|--------------------------------|
| 1. Engine mounts | 4. Flange locknuts (5/16 inch) |
| 2. Bolt—shown for clarity | 5. Front of the machine |
| 3. Undercarriage shroud | |

- Slip the forward mounting flanges of the undercarriage shroud over the bolts and carriage bolt at the engine-mount brackets of the machine ([Figure 96](#)).

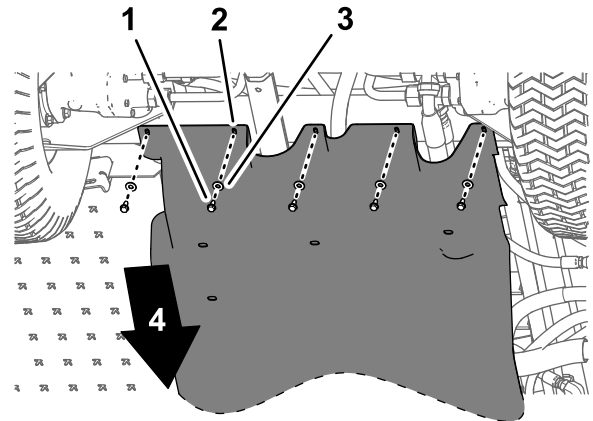

g189585

Figure 97

2017 machine shown; 2016 machines are similar

- | | |
|--|-------------------------|
| 1. Flange-head bolts (5/16 x 7/8 inch) | 3. Washers (5/16 inch) |
| 2. Undercarriage shroud | 4. Front of the machine |

- Assemble the rear part of the undercarriage shroud to the chassis ([Figure 97](#)) with the hardware that you removed in step 1 of 4 [Removing the Undercarriage Shroud](#) (page 9) as follows:
 - 2016 machines**—7 flange-head bolts (5/16 x 7/8 inch) and 7 washers (5/16 inch)
 - 2017 and later machines**—5 flange-head bolts (5/16 x 7/8 inch) and 5 washers (5/16 inch)
- Torque the nuts and bolts to 1129 to 1582 N·cm (100 to 140 in·lb).

17

Connecting the Rear Wire Harness

Parts needed for this procedure:

3	Cable tie
---	-----------

Routing the Wire Harness at the Manifold Mount

1. Route the 203 cm (80 inch) branch of the wire harness inboard of the support strut for the valve mount and rearward toward the 10-valve mount as shown in [Figure 98](#).

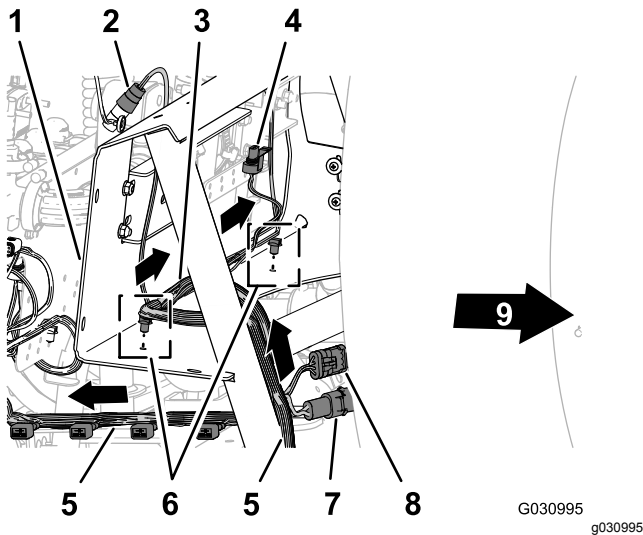

Figure 98

- | | |
|--|--------------------------------------|
| 1. Manifold mount | 6. Push-in fasteners |
| 2. 3-socket connector (flow meter) | 7. 2-pin connector (hose-reel power) |
| 3. 81 cm (32 inch) wire-harness branch—flow meter and agitation valve | 8. 3-socket connector (hose reel) |
| 4. Electrical connector (Agitation valve) | 9. Front of the machine |
| 5. 203 cm (80 inch) wire-harness branch—ASC10, lift cylinder solenoids, nozzle-valves 1 through 10 | |

2. Route the 81 cm (32 inch) wire-harness branch for the flow meter and agitation valve across the front of the manifold mount ([Figure 98](#)).

3. Insert the push-in fasteners of the 81 cm (32 inch) wire-harness branch into the holes in the lower flange of the manifold mount ([Figure 98](#)).

Routing the Wire Harness at the 10-Valve Mount

1. Route the 203 cm (80 inch) wire-harness branch across the back of the 10-valve mount with the 10 connectors for the nozzle valves rearward and below the valves ([Figure 99](#)).

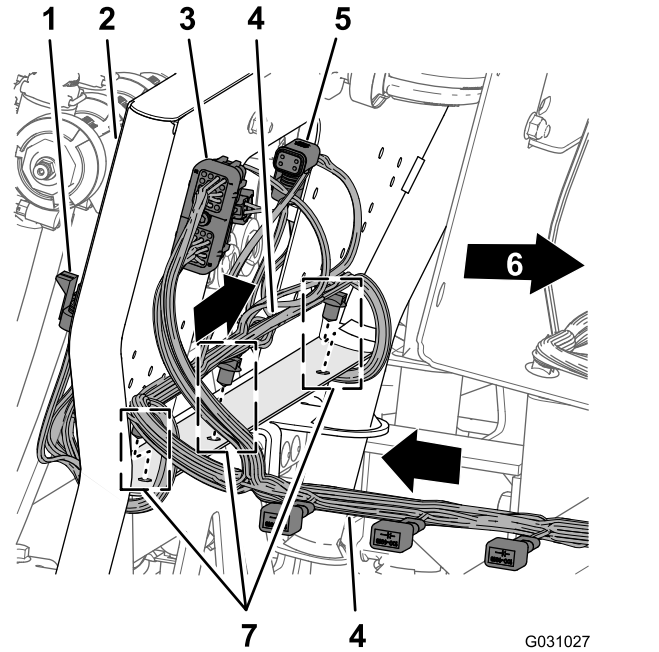

Figure 99

- | | |
|--|---------------------------------------|
| 1. 3-socket connector (nozzle-valve position 10) | 5. 4-socket connector (to the ASC 10) |
| 2. 10-valve mount | 6. Front of the machine |
| 3. 40-socket connector (ASC 10) | 7. Push-in fasteners |
| 4. 203 cm (80 inch) wire-harness branch—ASC10, lift cylinder solenoids, nozzle-valves 1 through 10 | |

2. Insert the push-in fasteners of the 203 cm (80 inch) wire-harness branch into the holes in the lower flange of the 10-valve mount ([Figure 99](#)).

Routing the Wire Harness for the Sprayer Pump

1. Route the 86 cm (34 inch) wire-harness branch for the spray-pump solenoid across the top of the sprayer frame channel and down toward the sprayer-pump solenoid ([Figure 100](#)).

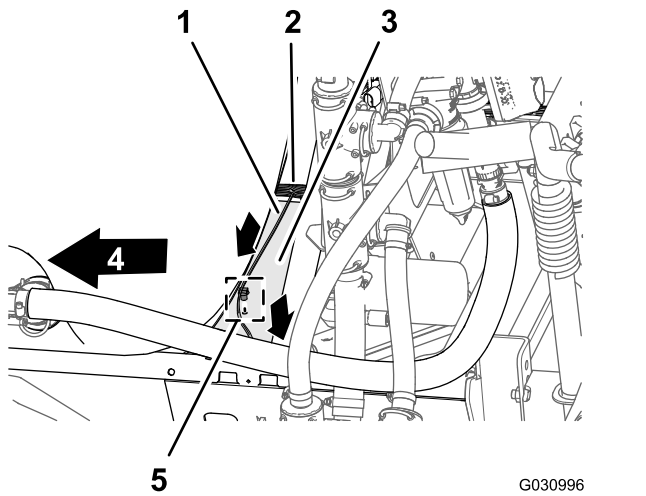

Figure 100

- | | |
|--|-------------------------|
| 1. 86 cm (34 inch) wire-harness branch—spray-pump solenoid | 4. Front of the machine |
| 2. 203 cm (80 inch) wire-harness branch—ASC10, lift cylinder solenoids, nozzle-valves 1 through 10 | 5. Push-in fastener |
| 3. Channel (sprayer frame) | |

2. Insert the push-in fastener of the 86 cm (34 inch) wire-harness branch into the hole in the sprayer frame channel ([Figure 100](#)).

Connecting the Wire Harness to the Manifold Mount Components

1. Route the connectors of the 203 cm (80 inch) wire-harness branch labeled **Flow Meter** and labeled **Pressure Transducer** rearward of the manifold mount ([Figure 101](#)).

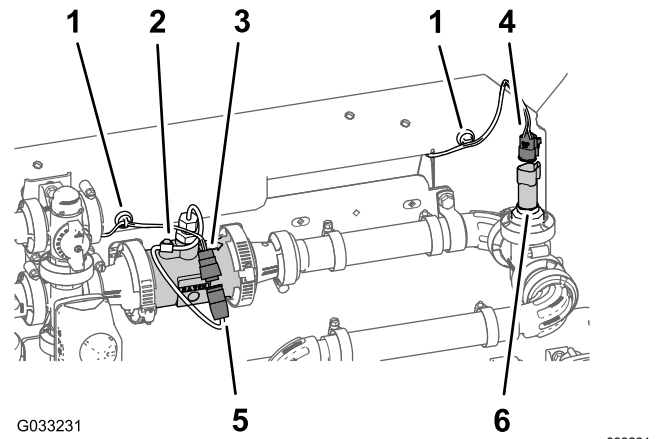

Figure 101

- | | |
|--|---|
| 1. Magnetic-harness anchor | 4. 3-socket connector (rear wire harness—labeled Pressure Transducer) |
| 2. Flow meter | 5. 3-pin connector (flow-meter harness) |
| 3. 3-socket connector (rear wire harness—labeled Flow Meter) | 6. 3-pin connector (pressure transducer) |

2. Connect the 3-socket connector of the 203 cm (80 inch) wire-harness branch for the flow meter (not labeled) into the 3-pin connector of the harness of the flow meter ([Figure 101](#)).
3. Connect the 3-socket connector of the 203 cm (80 inch) wire-harness branch for the labeled **Pressure Transducer** into the 3-pin connector of the pressure transducer ([Figure 101](#)).
4. Adhere the magnet-harness anchors for the flow meter and the pressure transducer onto the surface of the manifold mount ([Figure 101](#)).
5. Route the 3-pin connector for the harness of the agitation valve forward of the manifold mount ([Figure 102](#)).

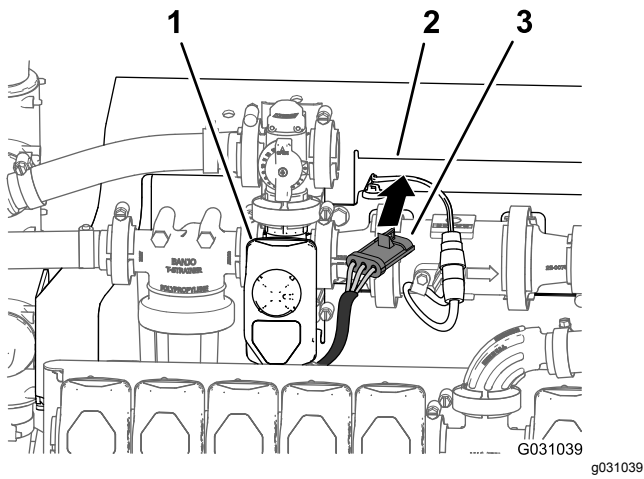

Figure 102

1. Agitation valve
2. Manifold mount
3. 3-socket connector (agitation-valve harness)

6. Connect the 3-pin connector for the harness of the agitation valve into the 3-socket connector of the 203 cm (80 inch) wire-harness branch labeled **Agitation Valve** (Figure 103).

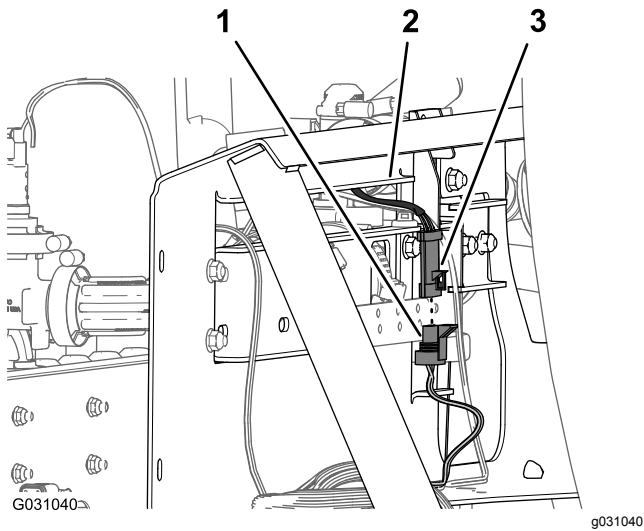

Figure 103

1. 3-pin connector (rear wire harness—labeled Agitation Valve)
2. Manifold mount
3. 3-socket connector (agitation-valve harness)

Connecting the Wire Harness to the Solenoids for the Lift-Cylinder Manifold

1. At the bottom of the lift-cylinder manifold, connect the 2-socket connector of the rear wire harness labeled **Enable Solenoid** into the 2-pin connector for the enable solenoid (Figure 104 and Figure 105).

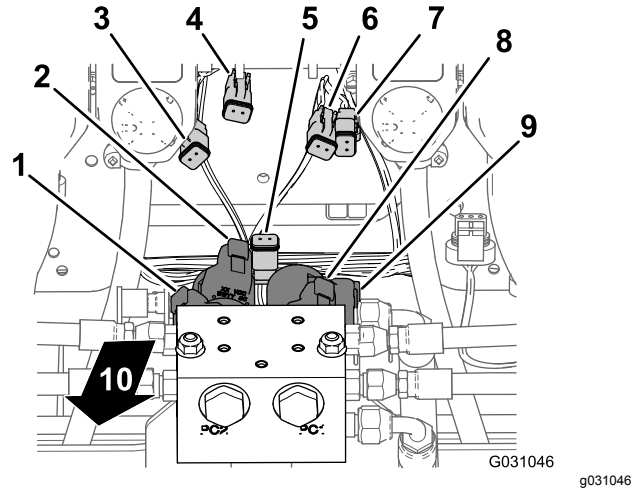

Figure 104

1. 2-pin connector—left down solenoid (lift-cylinder manifold)
2. 2-pin connector—left up solenoid (lift-cylinder manifold)
3. 2-socket connector—Left Down (main-harness connector)
4. 2-socket connector—Left Up (main-harness connector)
5. 2-socket connector—Enable Solenoid (main-harness connector)
6. 2-socket connector—Right Up (main-harness connector)
7. 2-socket connector—Right Up (main-harness connector)
8. 2-pin connector—right up solenoid (lift-cylinder manifold)
9. 2-pin connector—right down solenoid (lift-cylinder manifold)
10. Back of the machine

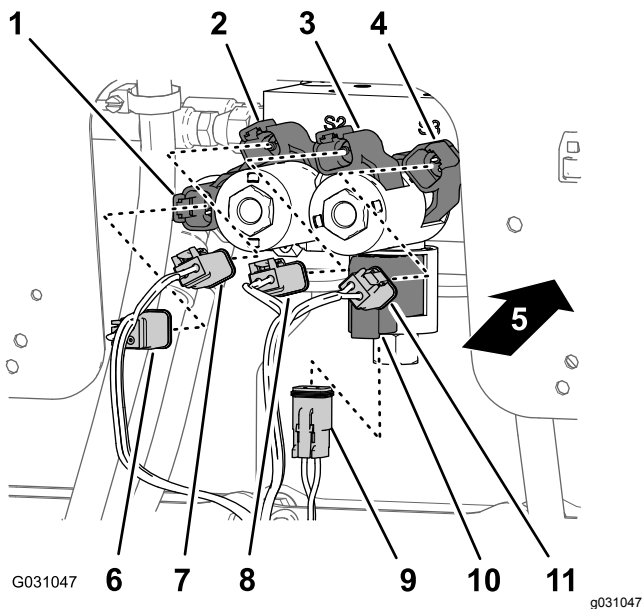

Figure 105

- | | |
|---|--|
| 1. 2-pin connector—right down solenoid (lift-cylinder manifold) | 7. 2-socket connector—Right Up (main-harness connector) |
| 2. 2-pin connector—right up solenoid (lift-cylinder manifold) | 8. 2-socket connector—Left Up (main-harness connector) |
| 3. 2-pin connector—left up solenoid (lift-cylinder manifold) | 9. 2-socket connector—Enable Solenoid (main-harness connector) |
| 4. 2-pin connector—left down solenoid (lift-cylinder manifold) | 10. 2-pin connector—enable solenoid (lift-cylinder manifold) |
| 5. Back of the machine | 11. 2-socket connector—Left Down (main-harness connector) |
| 6. 2-socket connector—Right Down (main-harness connector) | |

- At the lower right solenoid, connect the 2-socket connector of the rear wire harness labeled **Right Down** into the 2-pin connector for the right down solenoid (Figure 104 and Figure 105).
- At the upper right solenoid, connect the 2-socket connector of the rear wire harness labeled **Right Up** into the 2-pin connector for the right up solenoid (Figure 104 and Figure 105).
- At the lower left solenoid, connect the 2-socket connector of the rear wire harness labeled **Left Down** into the 2-pin connector for the left down solenoid (Figure 104 and Figure 105).
- At the upper left solenoid, connect the 2-socket connector of the rear wire harness labeled **Left Up** into the 2-pin connector for the left up solenoid.

Connecting the Wire Harness to the Sprayer Valves

- Route the 3-socket connectors of the 203 cm (80 inch) wire-harness branch with labels **Nozzle Valve 1** through **Nozzle Valve 5** rearward of the 10-valve mount and below nozzle valves 1 through 5 (Figure 106).

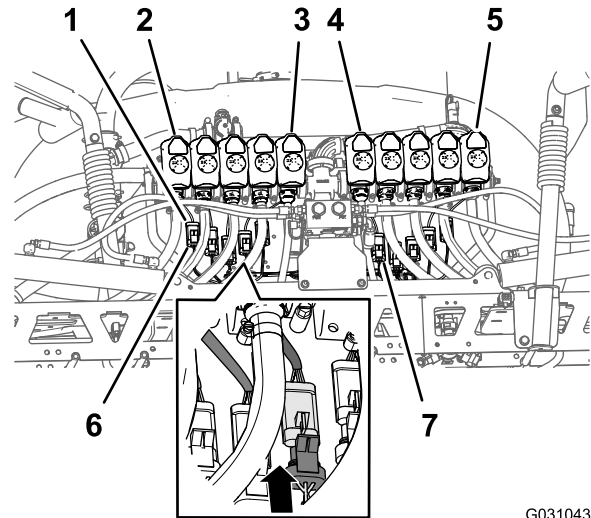

Figure 106

- | | |
|---|--|
| 1. 3-pin connector (nozzle-valve harness) | 5. Nozzle-valve 10 |
| 2. Nozzle-valve 1 | 6. 3-pin socket connector (rear wire harness—labeled Nozzle 1) |
| 3. Nozzle-valve 5 | 7. 3-pin socket connector (rear wire harness—labeled Nozzle 6) |
| 4. Nozzle-valve 6 | |

- Route the 3-socket connectors of the 203 cm (80 inch) wire-harness branch with labels **Nozzle Valve 6** through **Nozzle Valve 10** rearward of the 10-valve mount and below nozzle-valves 6 through 10 (Figure 106).
- Connect the 3-pin socket connector of the rear wire harness labeled **Nozzle 1** to the 3-pin connector of the harness for nozzle-valve 1 (Figure 106).

Important: It is important that you connect each labeled 3-pin socket connector of the rear wire harness to the correct 3-pin connector at each nozzle-valve position.

- Repeat step 3 at the nozzle-valve positions 2 through 10 (Figure 106).

Connecting the Wire Harness to the Sprayer Pump and the Speed Sensor

1. At the back of the machine—inboard of the sprayer pump, connect the 2-socket connector labeled **Spray Pump Solenoid** of the 86 cm (34 inch) wire-harness branch into the 2-pin connector of the relay for the pump (Figure 107).

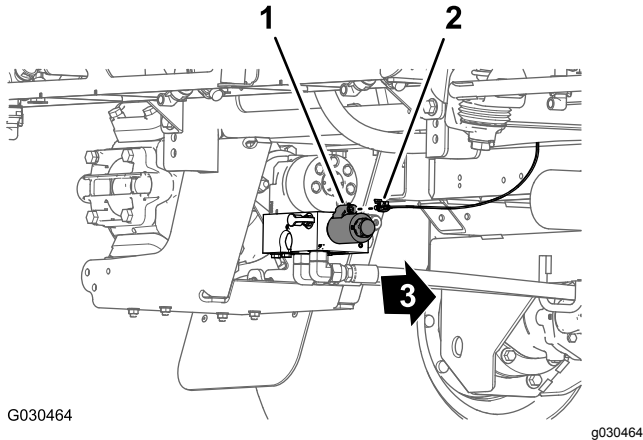

Figure 107

- | | |
|---|-------------------------|
| 1. 2-pin connector (pump relay) | 3. Front of the machine |
| 2. 2-socket connector—86 cm (34 inch) wire-harness branch | |

2. At back of the machine (between the right frame tube and the right fender) connect the 3-pin connector of the speed-sensor harness at the right hydraulic-traction motor from the 3-socket connector (unmarked) of the rear, main harness (Figure 108).

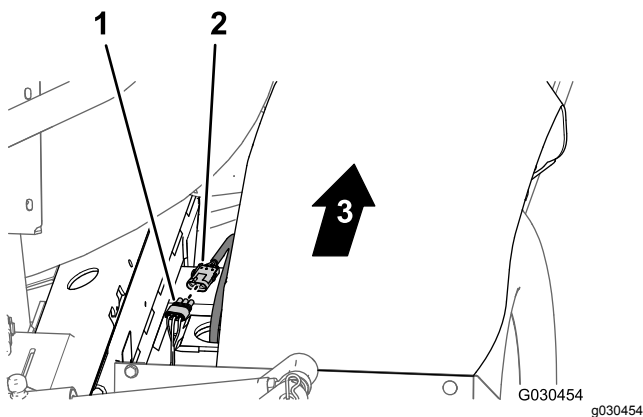

Figure 108

- | | |
|--|-------------------------|
| 1. 3-socket connector (rear, main harness) | 3. Front of the machine |
| 2. 3-pin connector (hydraulic-motor harness) | |

Routing the Wire Harness through the Engine Compartment

1. Route the 165 cm (65 inch) branch of the wire harness up and into the rear part of the engine compartment, along the right support for the engine shroud—forward of the duct that connects the air filter and the engine (Figure 109).

Note: You will secure the 165 cm (65 inch) branch of the rear wire harness in [Routing the Navigation Electrical Harness to the Battery](#) (page 61).

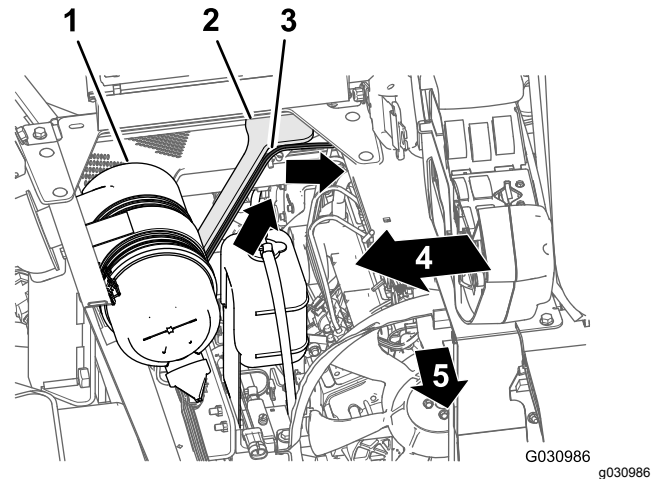

Figure 109

- | | |
|--|------------------------------|
| 1. Air filter (engine) | 4. Right side of the machine |
| 2. Engine-shroud support (right) | 5. Front of the machine |
| 3. 165 cm (65 inch) branch (rear wire harness) | |

2. Route the 165 cm (65 inch) branch of the wire harness across the seat-box angle and down along the left support for the engine shroud (Figure 110).

Note: You will secure the 165 cm (65 inch) branch of the rear wire harness in [Routing the Navigation Electrical Harness to the Battery](#) (page 61).

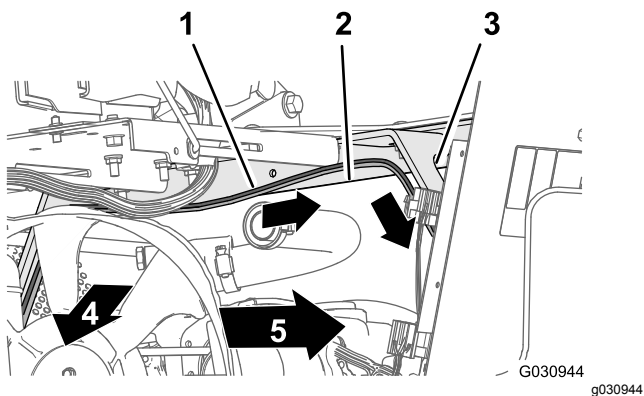

Figure 110

- | | |
|--|-----------------------------|
| 1. 165 cm (65 inch) branch (rear wire harness) | 4. Front of the machine |
| 2. Seat-box angle | 5. Left side of the machine |
| 3. Engine-shroud support (left) | |

3. Route the 165 cm (65 inch) branch of the wire harness down along the left support for the engine shroud and under the left frame tube (Figure 111).

Note: You will secure the 165 cm (65 inch) branch of the rear wire harness in [Routing the Navigation Electrical Harness to the Battery](#) (page 61).

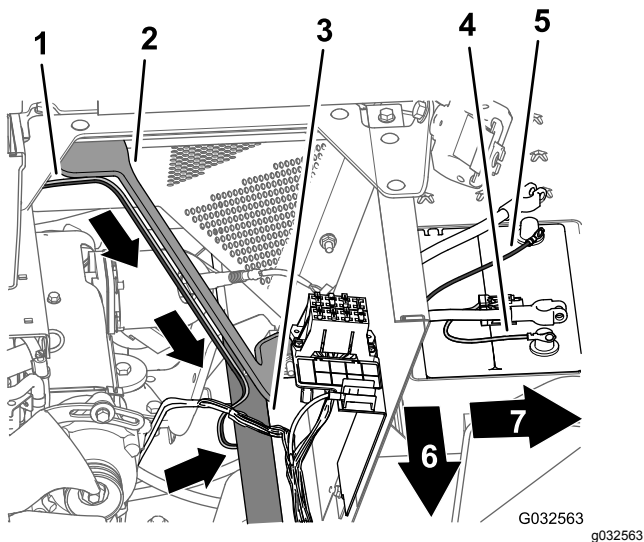

Figure 111

- | | |
|---|---|
| 1. 165 cm (65 inch) branch (rear wire harness) | 5. Negative terminal (black wire)—165 cm (65 inch) branch (rear wire harness) |
| 2. Engine-shroud support (left) | 6. Front of the machine |
| 3. Left frame tube | 7. Left side of the machine |
| 4. Positive terminal (red wire)—165 cm (65 inch) branch (rear wire harness) | |

4. Route the 50 A fuse and the positive- and negative-ring terminals of the 165 cm (65 inch) branch of the wire harness to the top of the battery (Figure 111).

Note: You will complete the installation of the ring terminals in [Assembling the Rear Harness and Navigation Electrical Harness to the Battery Cables](#) (page 64).

Routing the Wire Harness for the Sprayer Pump Shutoff Circuit

1. Rotate the driver's seat forward and place the prop rod for the seat into the detent in the console channel.
2. Remove the 5 flange-head bolts (1/4 x 3/4 inch) that secure the cover at the left side of the center console (Figure 112).

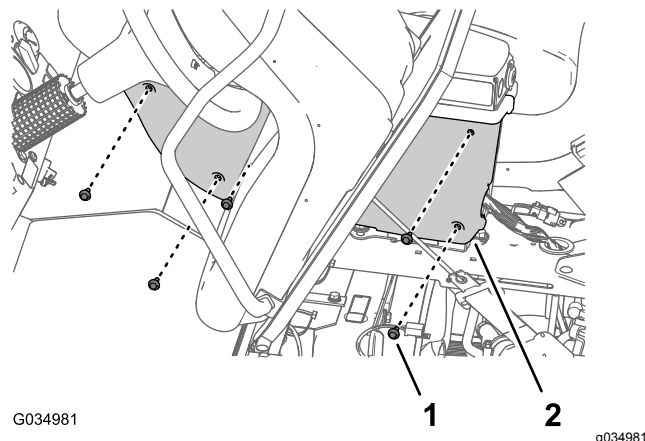

Figure 112

- | | |
|--------------------------------------|-------------------------------------|
| 1. Flange-head bolt (1/4 x 3/4 inch) | 2. Cover (left side—center console) |
|--------------------------------------|-------------------------------------|

3. Remove the cover from the center console (Figure 113).

Note: If needed, rotate the drivers seat down when removing the cover from the center console.

Adding the Sprayer Pump Shutoff Circuit to the Sprayer-Pump Switch

1. Press in the latch for the 8-socket connector at the sprayer-pump switch, and separate the connector from the switch ([Figure 115](#)).

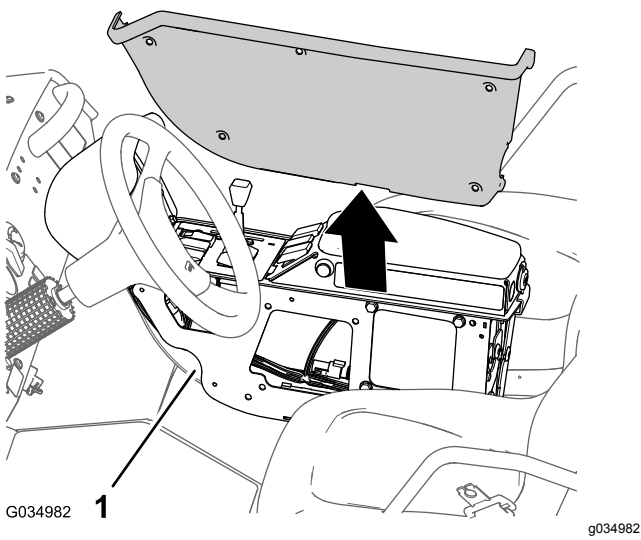

Figure 113

1. Console frame

4. Route the 81 cm (32 inch) branch of the rear-wire harness along the front wire harness and up through the grommet in the console channel ([Figure 114](#)).

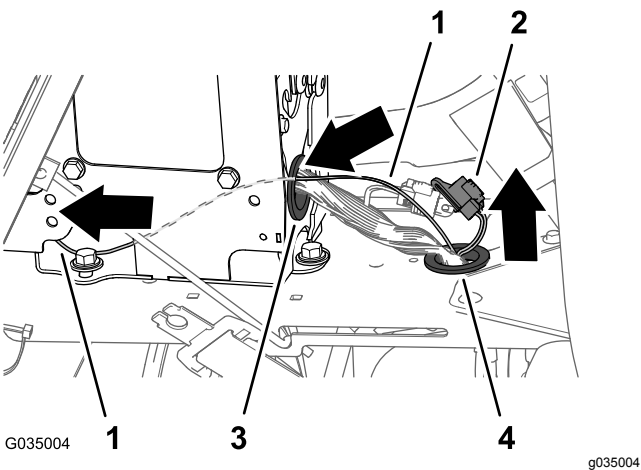

Figure 114

1. 81 cm (32 inch) wire-harness branch—sprayer pump shutoff circuit
2. 3-socket connector (CAN diagnostic)
3. Grommet (center console)
4. Grommet (console channel)

5. Route the 81 cm (32 inch) branch of the rear-wire harness forward along the front wire harness and through the grommet in the back of the center console ([Figure 114](#)).

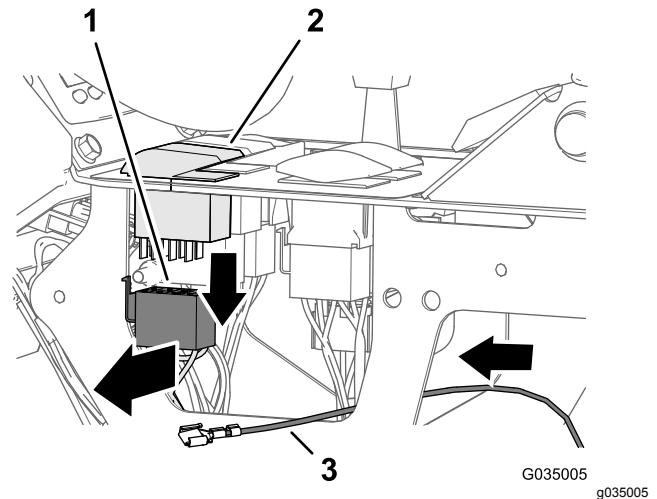

Figure 115

1. 8-socket connector (sprayer-pump switch)
2. Sprayer-pump switch
3. 81 cm (32 inch) wire-harness branch

2. Position the 8-socket connector so that you can see the back of the connector and the latch is up ([Figure 116](#)).

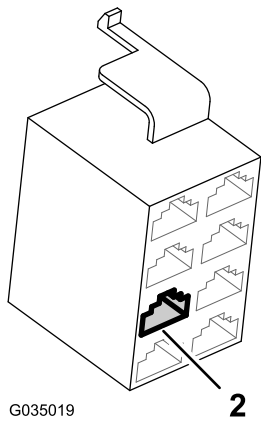
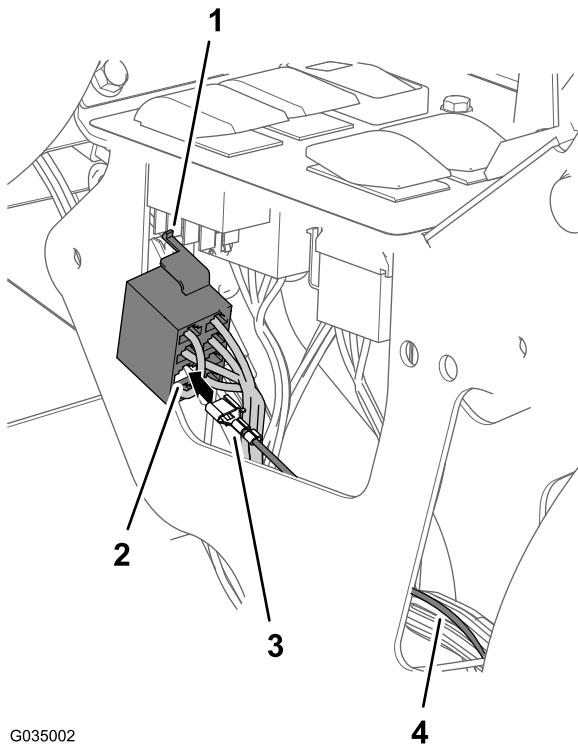

Figure 116

- | | |
|--|---|
| 1. Latch (8-socket connector) | 3. Terminal (81 cm (32 inch) wire-harness branch) |
| 2. Terminal-position #4 (8-socket connector—sprayer-pump switch) | 4. 81 cm (32 inch) wire-harness branch |

3. Insert the terminal at the end of the 81 cm (32 inch) branch of the rear-wire-harness into terminal position #4 of the 8-socket connector (Figure 116).

Note: Ensure that the latch of the terminal snaps securely into the 8-socket connector.

4. Connect the 8-socket connector if the wire harness with the 8-pin connector if the sprayer-pump switch (Figure 117).

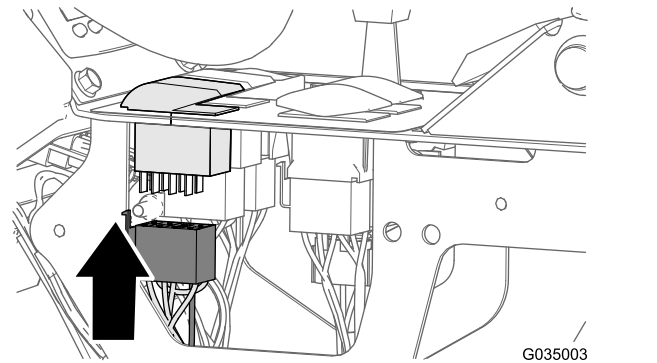

Figure 117

5. Secure the 81 cm (32 inch) branch of the rear-wire-harness to the front wire harness of the machine as shown in Figure 117.

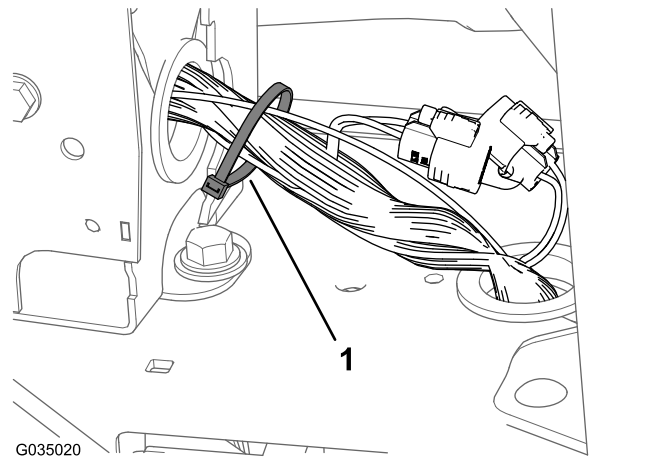
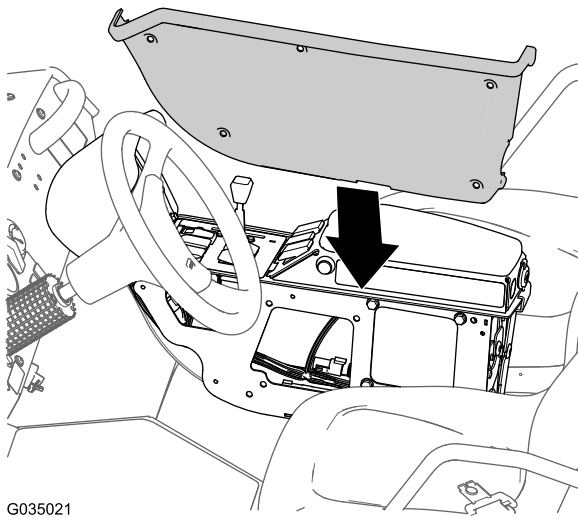

Figure 118

1. Cable tie

6. Align the cover that you removed in step 3 of [Routing the Wire Harness for the Sprayer Pump Shutoff Circuit \(page 51\)](#) to the left side of the center console (Figure 119).



G035021

g035021

Figure 119

7. Assemble the cover to the center console with the 5 flange-head bolts (1/4 x 3/4 inch) that you removed in step 2 of [Routing the Wire Harness for the Sprayer Pump Shutoff Circuit \(page 51\)](#), and torque the bolts to 520 to 678 N·cm (46 to 60 in-lb).

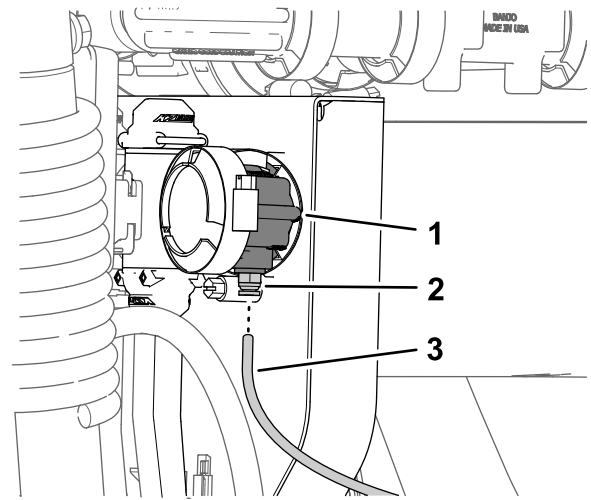

g189545

Figure 120

1. 90° elbow (nozzle valve 10)
2. Locking collar (tube coupler)
3. Pressure-sense tube (dash-pressure gauge)

2. Insert the sense tube into the locking collar until the tube is fully seated ([Figure 120](#)).

18

Connecting the Pressure-Sense Tube for the Dash Gauge

No Parts Required

Connecting the Pressure-Sense Tube for the Dash Gauge—Machines Without an Optional Hose Reel Kit

1. Align the end of the pressure-sense tube (plastic) for the pressure gauge in the dash with the locking collar for the tube coupler ([Figure 120](#)).

Connecting the Pressure Sense-Tube—Optional Spray Gun Kit or Optional Pivoting Hose Reel Kit

1. Align the end of the pressure-sense tube (plastic) for the pressure gauge in the dash with the locking collar for the tube coupler ([Figure 121](#) and [Figure 122](#)).

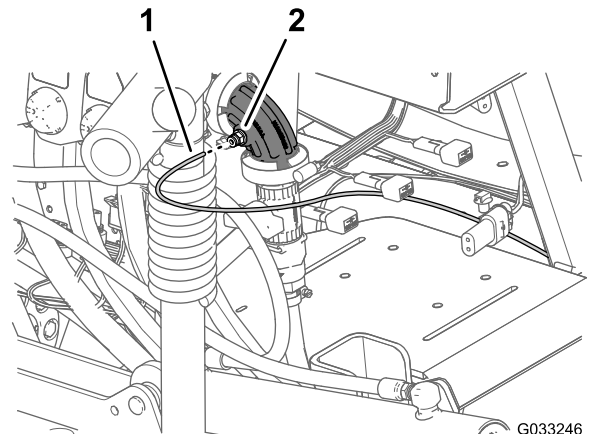

G033246

g033246

Figure 121

Optional Spray Gun Kit

1. Pressure-sense tube (dash gauge)
2. Tube coupler (90° elbow—nozzle valve 10)

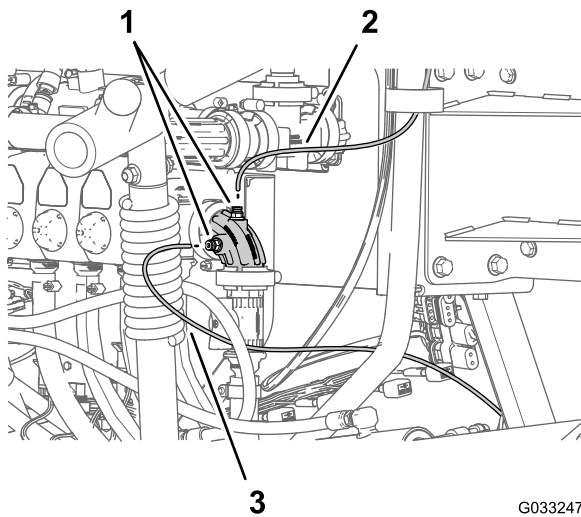

Figure 122

Optional Pivoting Hose Reel Kit

1. Pressure-sense tube (pivoting-reel gauge)
2. Tube couplers (90° elbow—nozzle valve 10)
3. Pressure-sense tube (dash gauge)

2. Insert the sense tube into the locking collar until the tube is fully seated (Figure 121 and Figure 122).

19

Installing the Navigation Receiver

Parts needed for this procedure:

1	Navigation receiver—GeoLink precision-spray-system kit (Model 41623—North America or 41630—International and North America)
1	Receiver mount
2	U-bolt
1	RTK-antenna bracket (use with the optional CDMA RTK correction modem kit or GSM RTK correction modem kit)
4	Flange locknut (3/8 inch)
3	Hex-head bolt (5 x 16 mm)
3	Washer (5 mm)
1	Cellular antenna (optional CDMA RTK correction modem kit or GSM RTK correction modem kit)
1	Coaxial cable (optional CDMA RTK correction modem kit or GSM RTK correction modem kit)

Assembling the Navigation Receiver to the Machine

1. Align the slot that is in the center of the receiver mount with the weld seam at the centerline of the ROPS tube (Figure 123).

Note: Ensure that the larger flange with 2 holes is rearward of the ROPS tube and the smaller flange with 1 hole is forward.

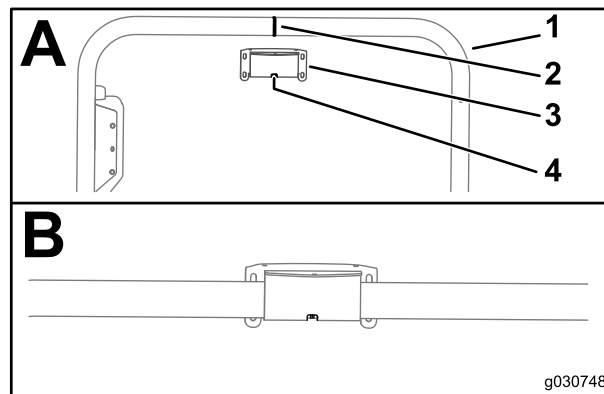

Figure 123

1. ROPS Tube
2. Weld seam (ROPS tube)
3. Receiver mount
4. Slot

2. Assemble the receiver mount to the ROPS tube as follows:

- If your machine is configured with global navigation satellite system (GNSS) with wide area augmentation system (WAAS), assemble the receiver mount to the ROPS tube (Figure 124) with the 2 U-bolts and 4 flange locknuts (3/8 inch).

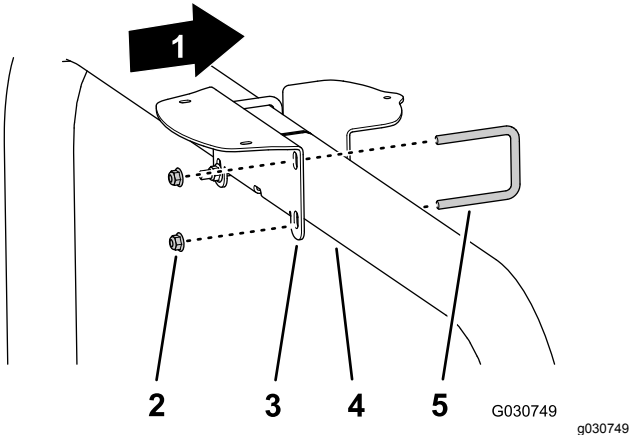

Figure 124

- | | |
|-------------------------------|--------------|
| 1. Front of the machine | 4. ROPS tube |
| 2. Flange locknuts (3/8 inch) | 5. U-bolt |
| 3. Receiver mount | |

- If your machine has GNSS and the CDMA or GSM RTK correction modem kit, assemble the receiver mount and RTK-antenna bracket to the ROPS tube (Figure 125) with the 2 U-bolts and 4 flange locknuts (3/8 inch).

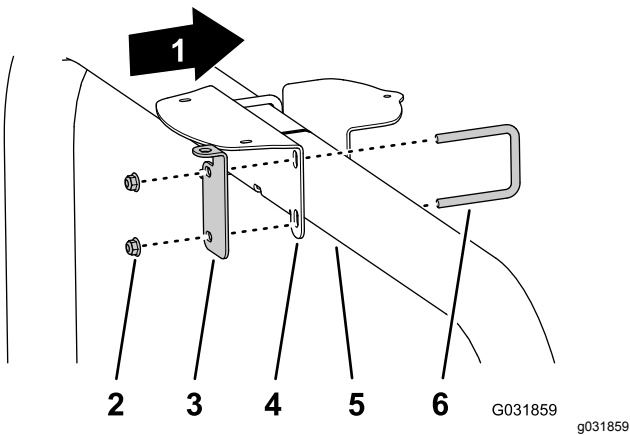

Figure 125

- | | |
|-------------------------------|-------------------|
| 1. Front of the machine | 4. Receiver mount |
| 2. Flange locknuts (3/8 inch) | 5. ROPS tube |
| 3. RTK-antenna bracket | 6. U-bolt |

3. Torque the nuts to 37 to 45 N·m (27 to 33 ft-lb).
4. Align the 3 threaded in the base of the navigation receiver to the 3 holes in the receiver mount (Figure 126).

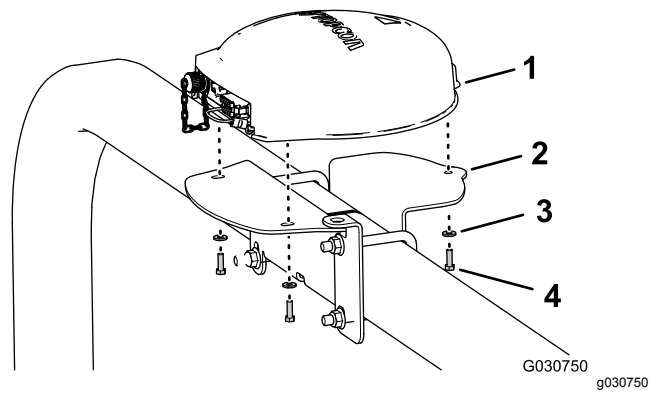

Figure 126

Shown with RTK-antenna bracket; machines with GNSS only are similar

- | | |
|------------------------|------------------------------|
| 1. Navigation receiver | 3. Washers (5 mm) |
| 2. Receiver mount | 4. Hex-head bolt (5 x 16 mm) |

5. Assemble the receiver to the mount (Figure 126) with the 3 hex-head bolt (5 x 16 mm) and 3 washers (5 mm).
6. Torque the 3 bolts to 576 to 712 N·cm (51 to 63 in-lb).

Installing the RTK Antenna to the Navigation Receiver

Note: Install the RTK antenna when you machine is equipped with a CDMA RTK or GSM RTK correction modem.

1. Align the coaxial coupler through the opening in RTK-antenna bracket with the bulkhead threads of the coupler down (Figure 127).

Note: Rotate the coaxial coupler as needed to align the flat of the bulkhead threads with the flat at the opening in RTK-antenna bracket.

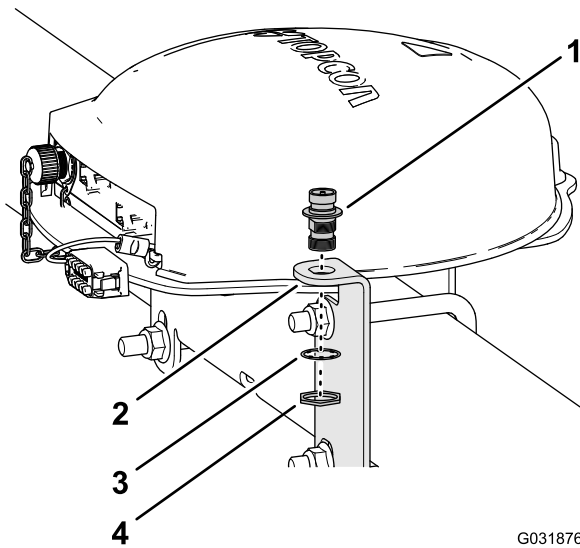

G031876
g031876

Figure 127

1. Coaxial coupler
2. RTK-antenna bracket
3. Lock washer
4. Jam nut

2. Assemble the coaxial coupler to the antenna bracket with the lock washer and jam nut, and tighten the jam nut by hand (Figure 127).
3. Assemble the RTK antenna onto the upper fitting of the coaxial coupler, and tighten the knurl nut of the antenna by hand (Figure 128).

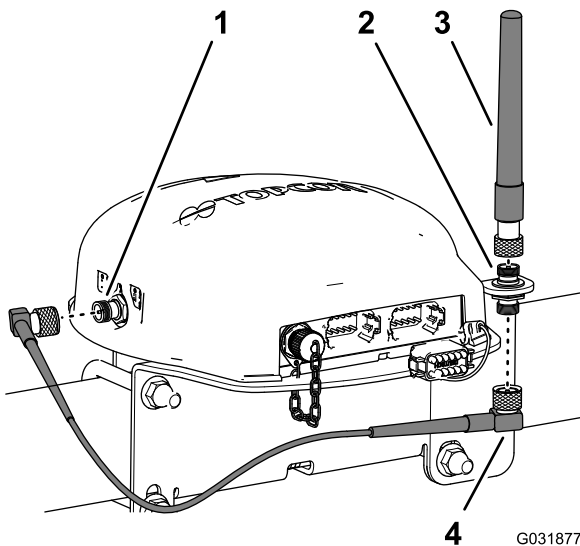

G031877
g031877

Figure 128

1. Coaxial connector (CDMA or GSM cellular modem)
2. Coaxial coupler
3. RTK-antenna
4. Flange-head bolt (1/4 x 1-1/2 inches)

4. Loosely assemble the antenna cable to the lower fitting of the coaxial coupler (Figure 128).
5. Route the cable around the back of the navigation receiver to the coaxial connector of the CDMA or GSM cellular modem (Figure 128).

6. Assemble the antenna cable to coaxial connector of the CDMA or GSM cellular modem (Figure 128).
7. Tighten the knurl nuts of the of the antenna cable by hand.

20

Installing the Sprayer Monitor

Parts needed for this procedure:

1	Sprayer Monitor—GeoLink precision-spray-system kit (Model 41623 for North America machines only or Model 41630 for both North America and international machines)
1	Ball mount—GeoLink precision-spray-system kit (Model 41623 for North America machines only or Model 41630 for both North America and international machines)
1	Monitor arm
1	Reinforcement plate
4	Flange-head bolts (1/4 x 1-1/2 inches)
4	Flange locknut (1/4 inch)

Preparing the Dash Panel

1. Locate the 4 hole punchouts (1/4 inch) in the dash panel that are located to the left of the grab handle (Figure 129).

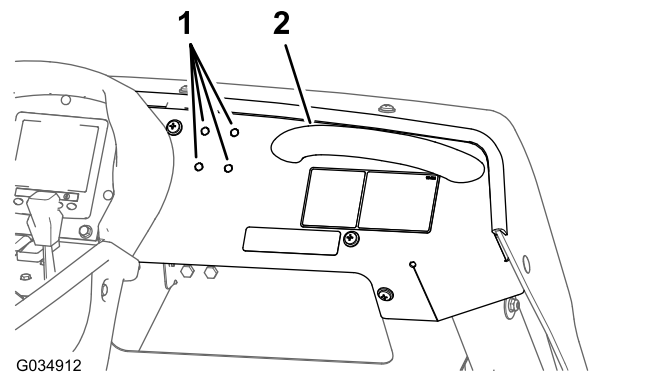

Figure 129

1. Hole punchouts (1/4 inch—dash panel)
2. Grab handle

2. Remove the 4 hole punchouts from the dash panel (Figure 129).

Mounting the Sprayer Monitor to the Dash of the Machine

1. Assemble the ball-pivot mount to the dash with the 4 flange-head bolts (1/4 x 1-1/2 inch), stiffener plate, and flange locknut (1/4 inch) as shown in [Figure 130](#).

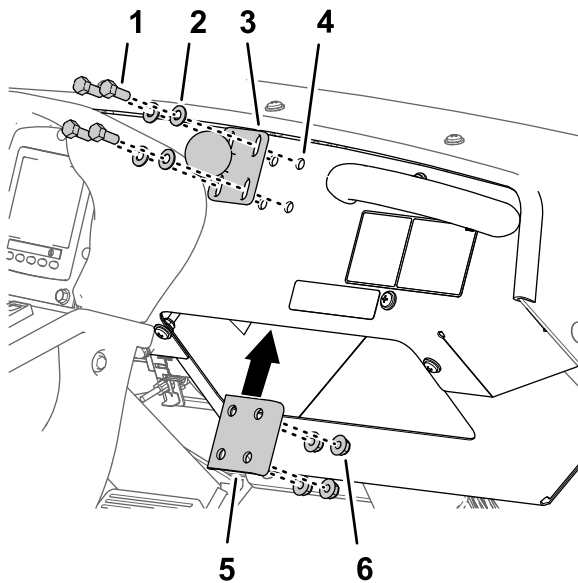

Figure 130

- | | |
|--|------------------------------|
| 1. Flange-head bolt (1/4 x 1-1/2 inch) | 4. Hole (dash panel) |
| 2. Washer (1/4 inch) | 5. Stiffener plate |
| 3. Ball-pivot mount | 6. Flange locknut (1/4 inch) |

2. Torque the bolts and nuts to 1,017 to 1,243 N·cm (90 to 110 in·lb).
3. Loosen the knob of the monitor arm until you can slip both the ball pivot for the fitting at the back of the sprayer monitor and the ball pivot for the mount at the dash panel into the socket monitor arm ([Figure 131](#)).

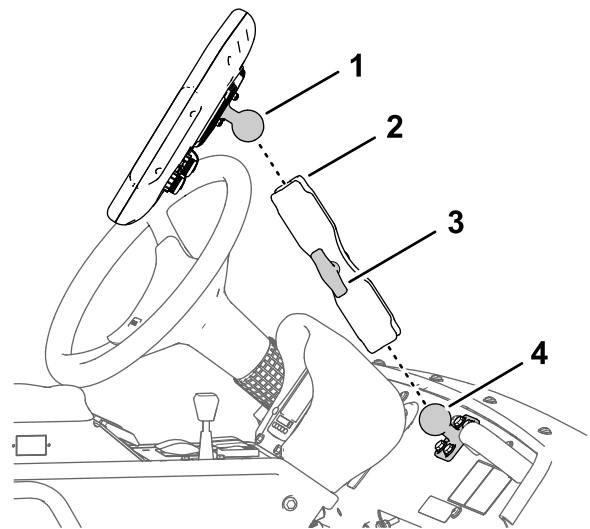

Figure 131

- | | |
|----------------|---------------------|
| 1. Ball pivot | 3. Knob |
| 2. Monitor arm | 4. Ball-pivot mount |

4. From the driver's seat (left seat), adjust to position of the sprayer monitor so that you can easily view the display screen ([Figure 131](#)).
5. Tighten the knob for the monitor arm by hand ([Figure 131](#)).

21

Installing the Wire Harnesses for the Navigation Components

Parts needed for this procedure:

1	Data Harness (navigation system)—GeoLink precision-spray-system kit (Model 41623—North America or 41630—International and North America)
1	Electrical Harness (navigation system)—GeoLink precision-spray-system kit (Model 41623—North America or 41630—International and North America)
6	Cable tie

Connecting the Navigation-Data and Electrical Harnesses

Important: Some connectors of the data harness are not used. Ensure that the caps and plugs of the unused connectors are secure.

Connect the 3-socket connector (electrical-power interface) of the navigation-electrical harness to the

3-pin connector (electrical-power interface) of the data harness (Figure 132).

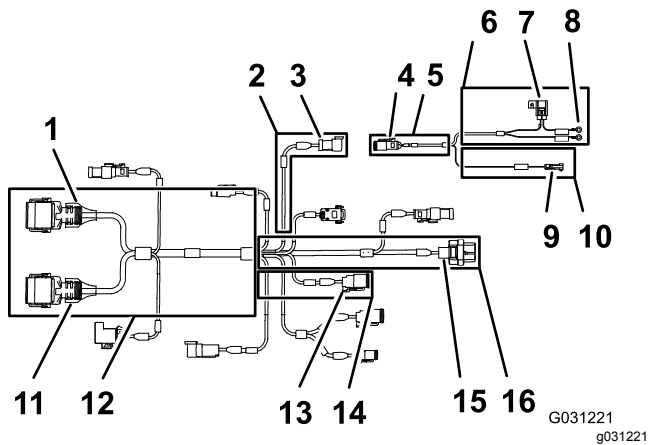

Figure 132

- | | | |
|--|---|---|
| 1. 12-socket connector (gray) data harness (navigation receiver) | 7. 10 A fuse (battery) | 13. 4-pin connector (rear harness interface for CAN 2 / sprayer controller) |
| 2. 100 cm (39-3/8 inch) data-harness branch (electrical power) | 8. Ring terminals (battery) | 14. 13 cm (5-1/16 inch) data-harness branch (rear harness interface) |
| 3. 3-pin connector —data harness (electrical-power interface) | 9. 1-pin connector —navigation -electrical harness (switched power) | 15. 26-socket connector —data harness (sprayer monitor) |
| 4. 3-socket connector —navigation -electrical harness (electrical-power interface) | 10. 100 cm (39-3/8 inch) electrical-harness branch (electrical power) | 16. 220 cm (86-5/8 inch) data-harness branch (sprayer monitor) |
| 5. 100 cm (39-3/8 inch) data-harness branch —(electrical-power interface) | 11. 12-socket connector (black) data harness (navigation receiver) | |
| 6. 220 cm (86-5/8 inch) electrical-harness branch (electrical-power interface) | 12. 390 cm (153-1/2 inch) data-harness branch (navigation receiver) | |

Routing and Connecting the Data Cable to the Navigation Receiver

1. Route the 390 cm (153-1/2 inch) branch of the data-harness into the right side of the engine compartment (adjacent to the air filter for the engine) and rearward under the bottom right area of the rear engine shroud (Figure 133).

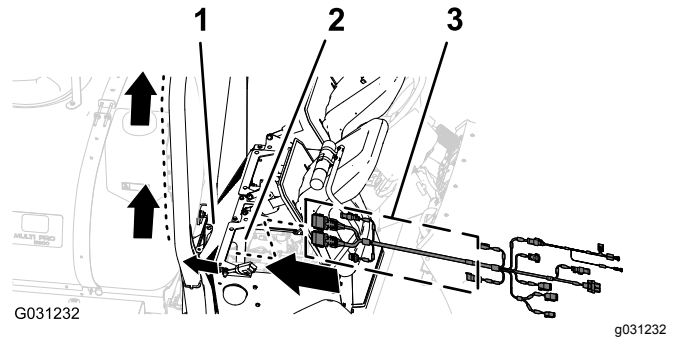

Figure 133

1. Rear engine shroud
2. Engine compartment
3. 390 cm (153-1/2 inch) branch (data-harness)

2. Route the 390 cm (153-1/2 inch) branch of the data harness along the right ROPS tube with the 12-socket connector (gray) and 12-socket connector (black) up toward the navigation receiver (Figure 134).

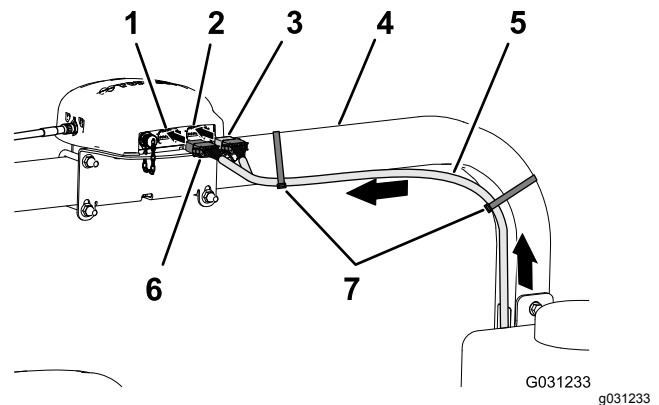

Figure 134

1. 12-pin connector left (gray)—navigation receiver
2. 12-pin connector right (black)—navigation receiver
3. 12-socket connector (black)—data harness
4. Right ROPS tube
5. 390 cm (153-1/2 inch) data-harness branch
6. 12-socket connector (gray/black)—data harness
7. Cable ties

3. Align the 2 keys at the long face of the gray and black 12-socket connector of the data harness with the 2 key slots in the bottom, horizontal wall of the left (gray) 12-pin connector of the navigation receiver (Figure 135).

Note: Use caution when connecting wire harness to the navigation receiver; the alignment keys of the harness connectors are unique to the keyways of the pin connectors of the navigation receiver.

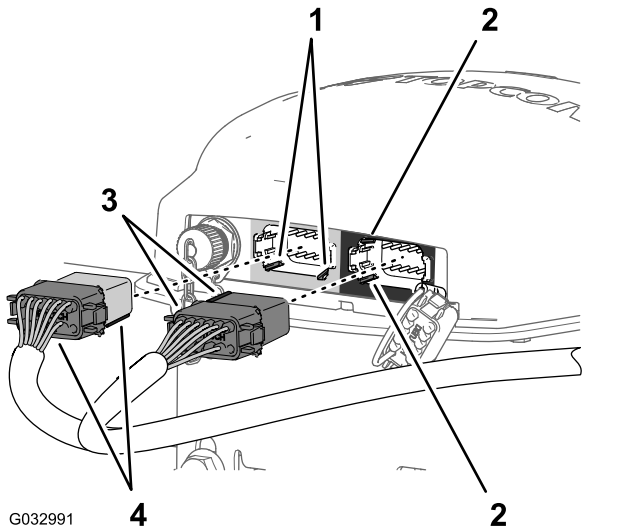

Figure 135

- | | |
|--|--|
| <ol style="list-style-type: none"> 1. Key slots—bottom, horizontal wall (left (gray) 12-pin connector—navigation receiver) 2. Key slots—left, vertical wall (right (black) 12-pin connector—navigation receiver) | <ol style="list-style-type: none"> 3. Alignment keys—short face (black) 12-socket connector—data harness) 4. Alignment keys—long face (gray/black) 12-socket connector—data harness) |
|--|--|

4. Connect the **gray and black** 12-socket connector of the data harness into the **left (gray)** 12-pin connector of the navigation receiver until the connector locks snap together securely ([Figure 135](#)).
5. Align the 2 keys at the short side of the **black** 12-socket connector of the data harness with the 2 key slots in the left, vertical wall of the **right (black)** 12-pin connector of the navigation receiver ([Figure 135](#)).

Note: Use caution when connecting wire harness to the navigation receiver; the alignment keys of the harness connectors are unique to the keyways of the pin connectors of the navigation receiver.

6. Connect the **black only** 12-socket connector of the data harness into the **left (black)** 12-pin connector of the navigation receiver until the connector locks snap together securely ([Figure 135](#)).
7. Secure the 390 cm (153-1/2 inch) branch of the data harness to the right ROPS tube with 2 cable ties as shown in [Figure 134](#).

Note: Ensure that the cable is slack between the 12-socket connectors and the cable tie.

Connecting the Navigation-Electrical and Data Harnesses to the Rear Wire Harness of the Machine

1. Route the 100 cm (39-3/8 inch) branch of the electrical harness ([Figure 136](#)) with the 1-pin connector, down to the area where the front and rear wire harness for the machine connect; refer to [Figure 92](#) in [Connecting the Front and Rear Wire Harnesses](#) (page 41).

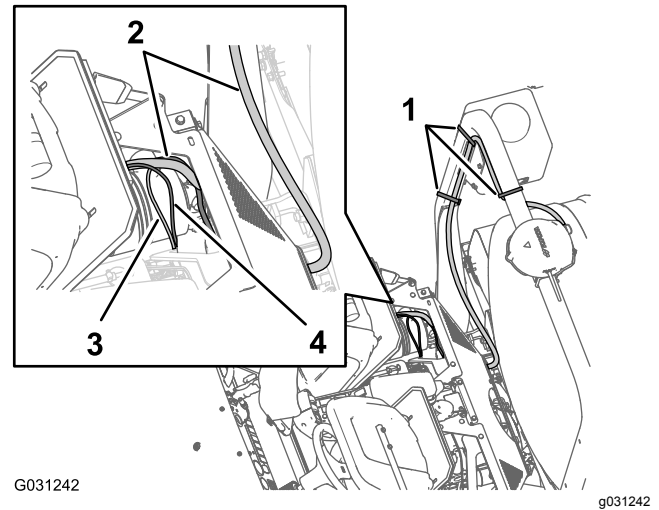
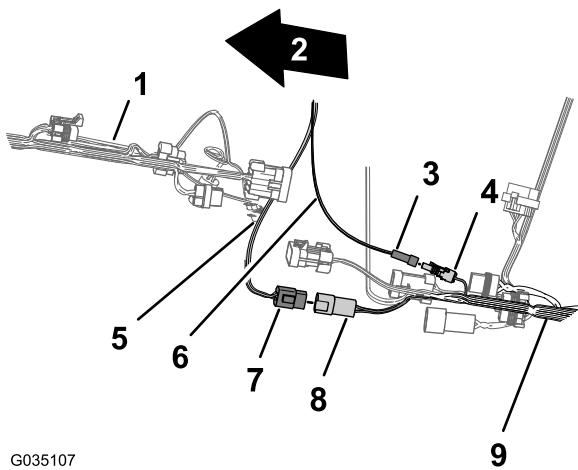

Figure 136

- | | |
|---|--|
| <ol style="list-style-type: none"> 1. Cable ties 2. 390 cm (153-1/2 inch)—data-harness branch | <ol style="list-style-type: none"> 3. 100 cm (39-3/8 inch)—electrical-harness branch 4. 100 cm (39-3/8 inch)—data-harness branch |
|---|--|

2. Route the 100 cm (39-3/8 inch) branch of the data harness ([Figure 136](#)) with the 4-pin connector for the CAN 2 / sprayer controller, down to the area where the front and rear wire harness for the machine connect; refer to [Figure 92](#) in [Connecting the Front and Rear Wire Harnesses](#) (page 41).
3. Connect the 4-pin connector of the data harness for the CAN 2 / sprayer controller into the 4-socket connector of the rear harness for the CAN 2 / sprayer-controller circuit ([Figure 137](#)).



G035107

g035107

Figure 137

- | | |
|---|--|
| 1. Front of the machine | 6. Electrical harness (switched power) |
| 2. Front wire harness of the machine | 7. 4-pin connector—data harness (CAN 2 / sprayer controller) |
| 3. 1-pin connector—electrical-harness branch (switched power) | 8. 4-socket connector—rear wire harness (CAN 2 / sprayer controller) |
| 4. 1-socket connector—rear wire harness (switched power) | 9. Rear wire harness of the machine |
| 5. Data harness (CAN 2 / sprayer controller) | |

-
4. Connect the 1-pin connector of the electrical-harness to the 1 socket connector of the rear wire harness (Figure 137).

Routing the Navigation Electrical Harness to the Battery

1. Route the 220 cm (86-5/8 inch) branch of the electrical harness for the navigation system across the seat-box angle and down along the left support for the engine shroud (Figure 138).

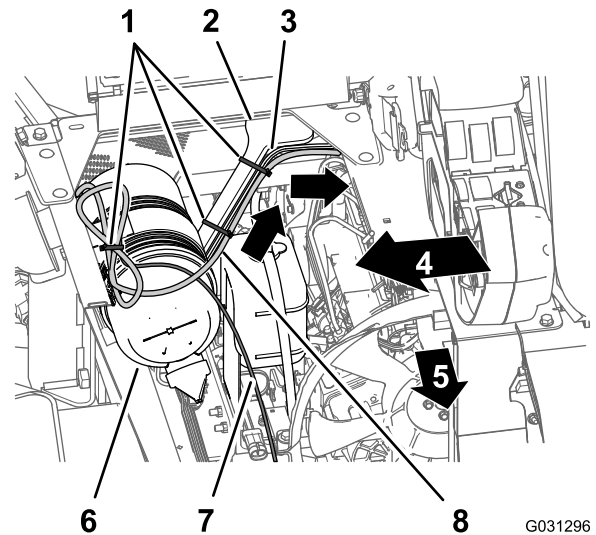

G031296

g031296

Figure 138

- | | |
|--|--|
| 1. Cable ties | 5. Front of the machine |
| 2. Engine-shroud support | 6. Air filter (engine) |
| 3. 165 cm (65 inch) branch (rear wire harness) | 7. 220 cm (86-5/8 inch) branch (data-harness) |
| 4. Right side of the machine | 8. 220 cm (86-5/8 inch) branch (navigation-electrical-harness) |

-
2. Secure the harness to the engine-shroud support with cable ties (Figure 138).
 3. Route the 220 cm (86-5/8 inch) branch of the electrical-harness for the navigation system down along the left support for the engine shroud and under the left frame tube (Figure 139).

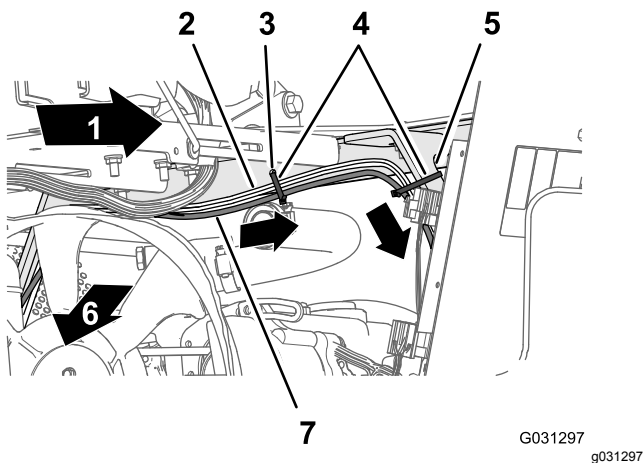

Figure 139

G031297
g031297

- | | |
|--|--|
| 1. Left side of the machine | 5. Engine-shroud support |
| 2. 165 cm (65 inch) branch (rear wire harness) | 6. Front of the machine |
| 3. Hole in the seat-box angle) | 7. 220 cm (86-5/8 inch) branch (navigation-electrical-harness) |
| 4. Cable ties | |

4. Secure the harness to the hole in the seat-box angle and the engine-shroud support with 3 cable ties (Figure 139 and Figure 140).

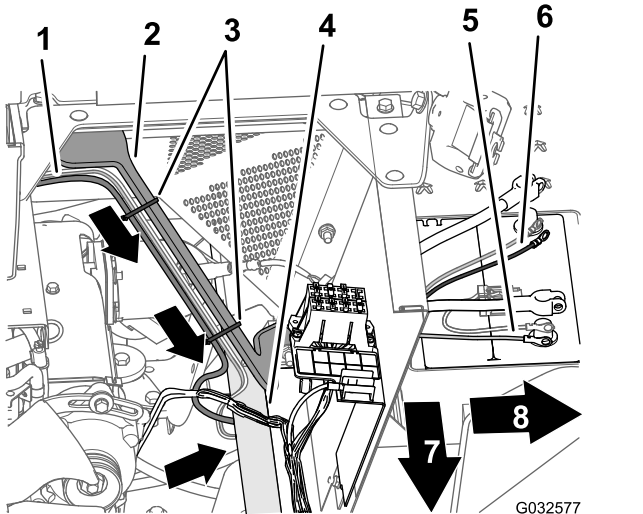

Figure 140

G032577
g032577

- | | |
|--|--|
| 1. 165 cm (65 inch) branch (rear wire harness) | 5. Negative-ring terminal (black wire)—165 cm (65 inch) branch (rear wire harness) |
| 2. Engine-shroud support | 6. Positive-ring terminal (red wire)—165 cm (65 inch) branch (rear wire harness) |
| 3. Cable ties | 7. Front of the machine |
| 4. Left frame tube | 8. Left side of the machine |

5. Route the 10 A fuse and the positive- and negative-ring terminals of the 220 cm (86-5/8 inch) branch of the electrical-harness for the

navigation system to the top of the battery (Figure 140).

Note: You will complete the installation of the ring terminals in [Routing the Navigation Electrical Harness to the Battery](#) (page 61).

Routing and Connecting the Data Cable to the Sprayer Monitor

- At the right side of the engine compartment, route the 220 cm (86-5/8 inch) branch of the data harness forward of the air filter for the engine and down toward the lower right corner of the radiator (Figure 141).

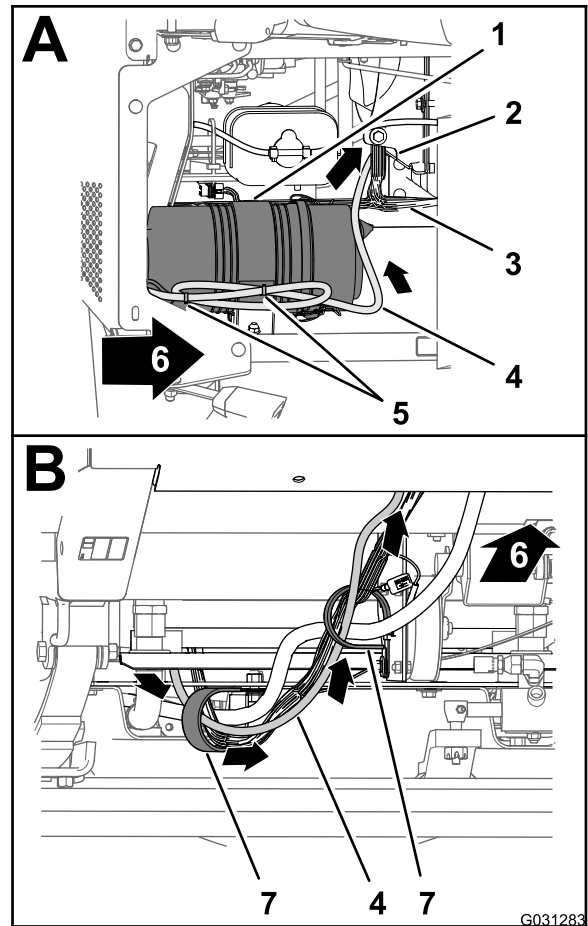

Figure 141

g031283

- | | |
|---|-------------------------|
| 1. air filter (engine) | 5. Cable ties |
| 2. Radiator | 6. Front of the machine |
| 3. Front wire harness of the machine | 7. R-clamps |
| 4. 220 cm (86-5/8 inch) data-harness branch | |

- Route the route the 220 cm (86-5/8 inch) branch of the data harness forward and through the 2 R-clamps at the bottom of the machine (Figure 141).

- Route the route the 220 cm (86-5/8 inch) branch of the data harness forward and up through grommet that surrounds the hole in the floor panel (Figure 142).

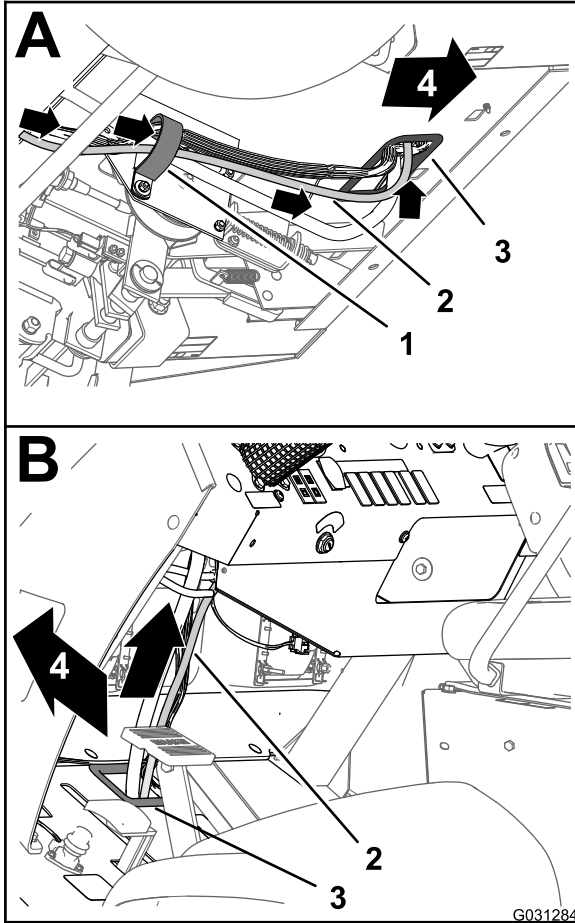

Figure 142

- R-clamp
- 220 cm (86-5/8 inch) data-harness branch
- Grommet (floor pan)
- Front of the machine

- Route the route the 220 cm (86-5/8 inch) branch of the data harness up and along the front wire harness of the machine (Figure 142).
- Route the route the 220 cm (86-5/8 inch) branch of the data harness up through grommet that surrounds the hole in the dash panel (Figure 143).

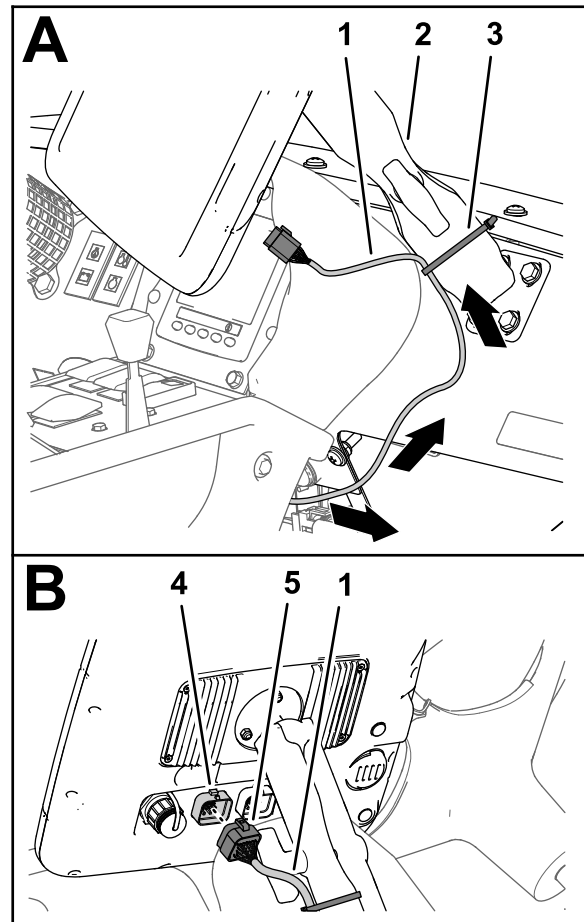

Figure 143

- 220 cm (86-5/8 inch) data-harness branch
- Monitor arm
- Cable tie
- 26-pin connector (sprayer display)
- 26-socket connector—data harness (sprayer monitor)

- Align the 26-socket connector of the data harness with the 26-pin connector of the sprayer display and press the socket connector into the pin connector until the latch of the connector snaps securely (Figure 143).
- Secure the 220 cm (86-5/8 inch) data-harness branch to the monitor arm with a cable tie (Figure 143).

Assembling the Rear Harness and Navigation Electrical Harness to the Battery Cables

1. Route the positive terminal (red wire), negative terminal (black wire), and fues block (50 A) of the rear wire harness up between the battery box and the chassis of the machine (Figure 144).

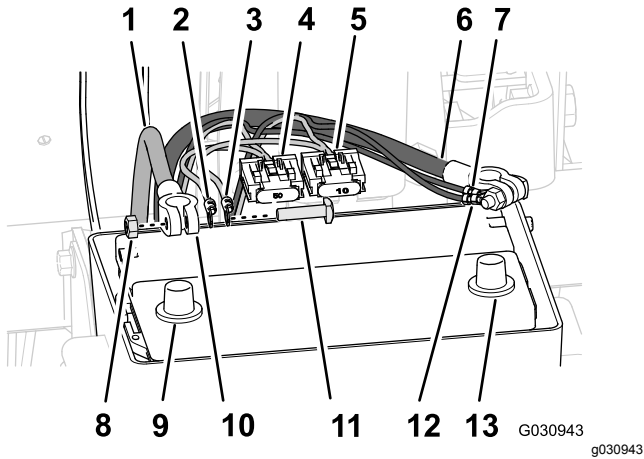

Figure 144

- | | |
|--|---|
| 1. Positive battery cable | 8. Battery post (positive) |
| 2. Positive-ring terminal (red wire)—165 cm (65 inch) branch (rear wire harness) | 9. Terminal (battery cable) |
| 3. Positive-ring terminal (red wire)—220 cm (86-5/8 inch) branch (navigation-electrical harness) | 10. T-bolt |
| 4. 50 A fuse block—rear wire harness | 11. Negative-ring terminal (black wire)—165 cm (65 inch) branch (rear wire harness) |
| 5. 10 A fuse block—navigation-electrical harness | 12. Negative-ring terminal (black wire)—220 cm (86-5/8 inch) branch (navigation-electrical harness) |
| 6. Negative battery cable | 13. Battery post (negative) |
| 7. Hex nut | |

5. Loosely secure the terminals and the T-bolt with a hex nut (Figure 144).

Note: Do not install the battery cable to the battery at this time.

6. Assemble a T-bolt through the negative terminal (black wire) of the rear wire harness, the negative terminal of the navigation-electrical harness, and terminal of the negative battery cable (Figure 144).

7. Loosely secure the terminals and the T-bolt with a hex nut (Figure 144).

Note: Do not install the battery cables to the battery at this time.

2. Route the positive terminal (red wire), negative terminal (black wire), and 10 A fuse block of the navigation-electrical harness up between the battery box and the chassis of the machine.
3. Remove the T-bolts and hex nuts from the terminals of the positive and negative battery cables (Figure 144).
4. Assemble a T-bolt through the positive terminal (red wire) of the rear wire harness, the positive terminal of the navigation-electrical harness, and terminal of the positive battery cable (Figure 144).

22

Connecting the Wire Harness for the Optional Pivoting Hose-Reel Kit

No Parts Required

Procedure

1. At the back of the machine, locate the wire harness for the electric hose-reel kit at the back of the sprayer tank (A of [Figure 145](#)).

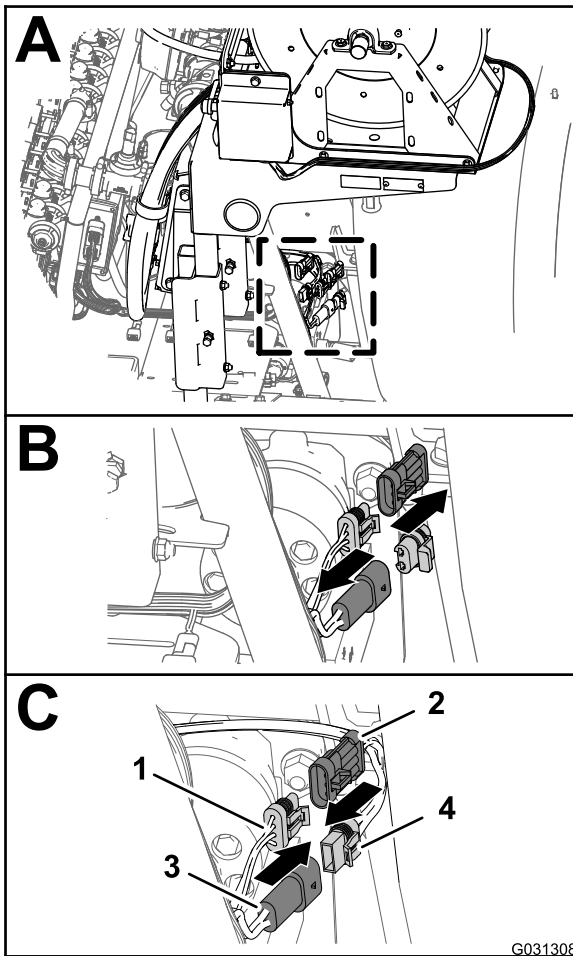

Figure 145

- | | |
|---|--|
| 1. 3-socket connector (rear, main harness) | 3. 2 socket pin (rear, main harness) |
| 2. 3-pin connector (harness—electric-hose reel) | 4. 2 socket connector (harness—electric-hose reel) |

2. Remove the plug from the 2 pin connector of the rear, main harness for the hose-reel power (B in [Figure 145](#)).
3. Connect the 2 socket connector of the harness for the electric-hose reel into the 2 pin connector of the rear, main harness (C in [Figure 145](#)).
4. Remove the cap from the 3-socket connector of the rear, main harness for the spray harness interconnect (B in [Figure 145](#)).
5. Connect the 3 pin connector of the harness for the electric-hose reel into the 3 pin socket of the rear, main harness (C in [Figure 145](#)).

23

Connecting the Compressor Wire Harness for the Optional Foam-Marker Kit

No Parts Required

Procedure

1. At the end of the 236 cm (93 inch) branch of the wire harness, align the 4-socket connector of the wire harness for the finishing kit with the 4-pin connector of the wire harness from the compressor ([Figure 146](#)).

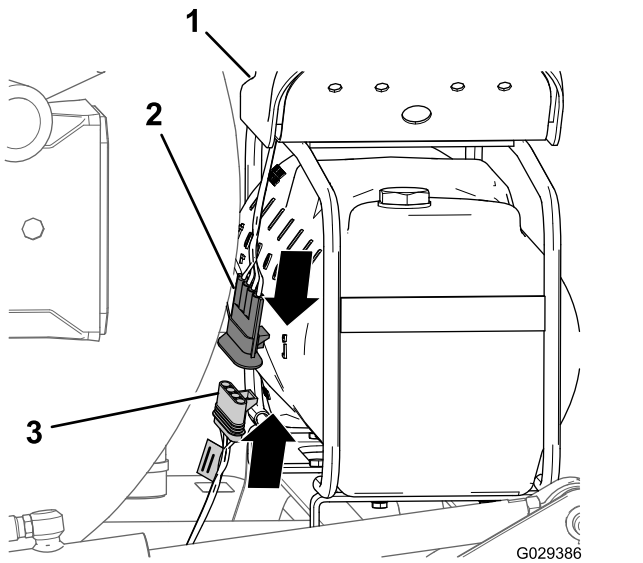

Figure 146

1. Compressor
2. 4-pin connector (wire harness for the compressor)
3. 4-socket connector (wire harness for the finishing kit)

2. Insert the 4-pin connector into the 4-socket connector (Figure 146).

Note: Press the connectors together until the latch snaps securely.

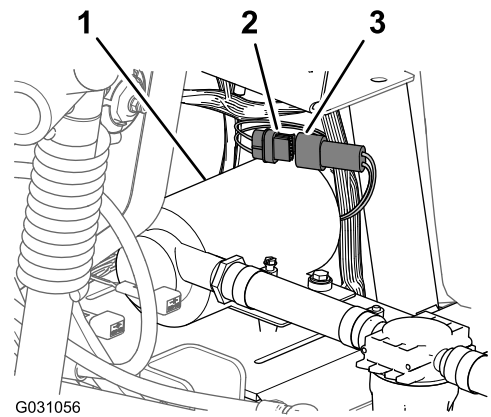

Figure 147

1. Rinse pump
2. 6-socket connector (rear, main harness)
3. 6-pin connector (rinse-pump harness)

2. Align the rinse-pump cover over the saddle plate for the rinse pump (Figure 148).

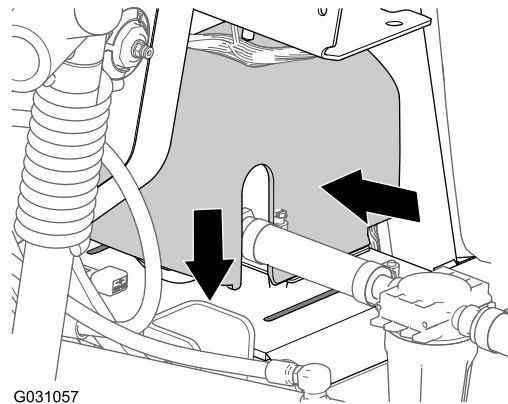

Figure 148

3. Press together the sides of the rinse-pump cover and align the tabs of the cover with the saddle plate (Figure 148).
4. Insert the tabs into the slots and release the sides of the cover (Figure 148).

24

Connecting the Optional Tank-Rinse Kit

No Parts Required

Procedure

1. Connect the 6-pin connector of the rinse-pump harness from the 6-socket connector of the rear, main harness (Figure 147).

25

Completing the Installation of the GeoLink Spray System-Finishing Kit

No Parts Required

Connecting the Battery

1. Move the prop rod for the seats into the slots and tilt the seats down.
2. Connect the positive (red) cable to the positive (+) battery post and the negative (black) cable to the negative (-) battery post using the bolts and nuts; refer to [Figure 2](#) in [Disconnecting the Battery](#) (page 6).
3. Slide the insulator boot over both battery posts ; refer to [Figure 2](#) in [Disconnecting the Battery](#) (page 6).
4. Install the battery cover and secure it with the strap; refer to [Figure 1](#) in [Disconnecting the Battery](#) (page 6).

Programming the Machine Settings

1. Insert the key into the key switch and rotate the switch to the ON position.
Note: Do not start the engine.
2. At the splash screen, press and hold the button 5 (far right) on the InfoCenter to access the Main Menu screen ([Figure 149](#)).



G035069

g035069



G035082

g035082

Figure 149

1. Button 5

3. On the Main Menu, press button 1 or button 2 until the Settings option is highlighted, and press button 4 to navigate to the Settings menus ([Figure 150](#)).

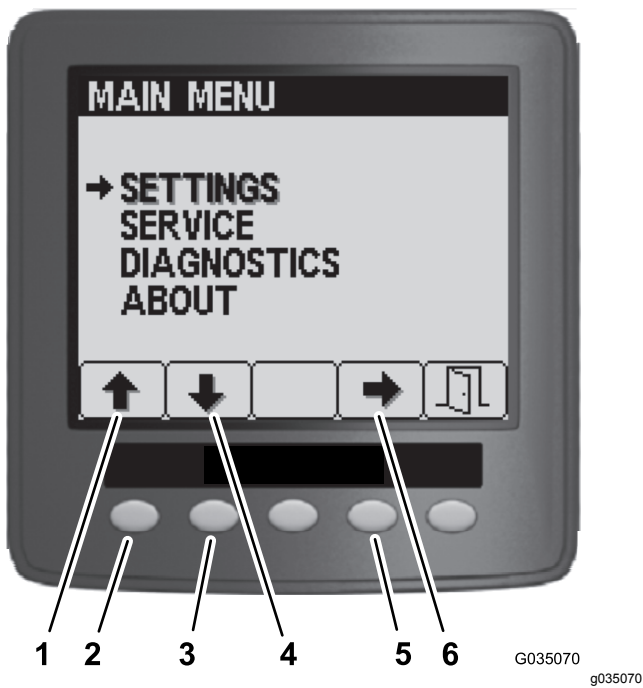

Figure 150

- | | |
|---------------|-----------------|
| 1. Up arrow | 4. Button 2 |
| 2. Button 1 | 5. Button 4 |
| 3. Down arrow | 6. Select arrow |

4. On the Settings menu, press button 1 or button 2 until the GeoLink option is highlighted, and press button 4 to navigate to the GeoLink menu (Figure 151).

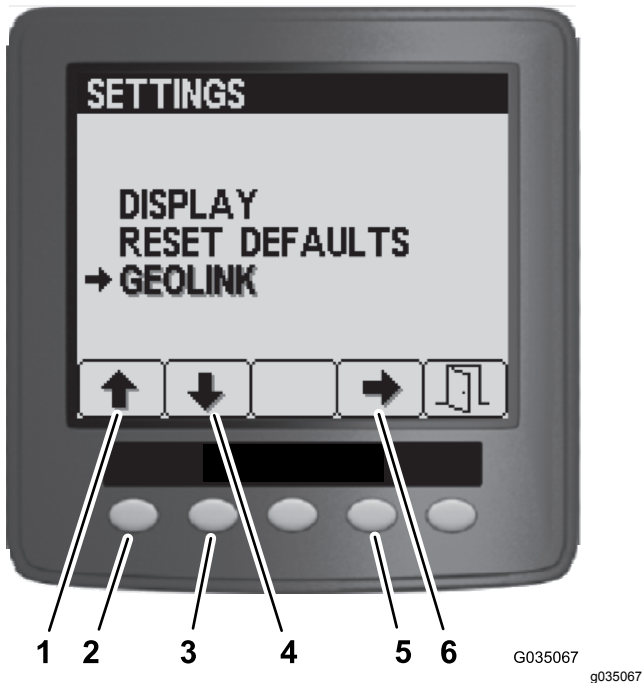

Figure 151

- | | |
|---------------|-----------------|
| 1. Up arrow | 4. Button 2 |
| 2. Button 1 | 5. Button 4 |
| 3. Down arrow | 6. Select arrow |

5. On the GeoLink menu, press button 4 to select the Yes option, and press the button 5 to save your settings and exit the menu (Figure 152).

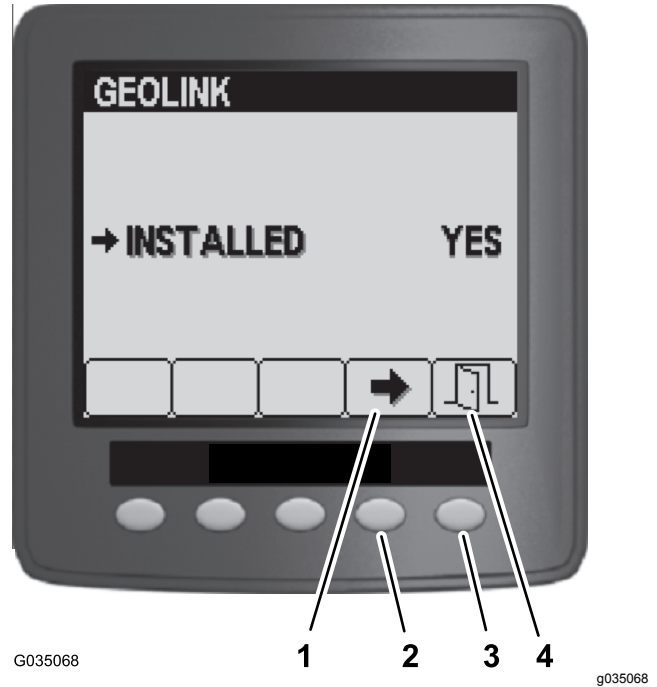

Figure 152

- | | |
|-----------------|-------------|
| 1. Button 4 | 3. Button 5 |
| 2. Select arrow | 4. Exit |

6. Rotate the key switch to the OFF position (Figure 153).



Figure 153

7. Rotate the key switch to the ON position (Figure 153).

Note: The splash screen for the GeoLink system should display in the InfoCenter.



G035066

Figure 154

g035066

8. Rotate the key switch to the OFF position.

26

Powering the GeoLink Components

No Parts Required

Procedure

1. Turn the ignition key to the RUN (gasoline) or PREHEAT/RUN (diesel) position.
2. Verify that the following components indicate that each receives power:
 - Control console—displays graphics and text ([Figure 155](#))

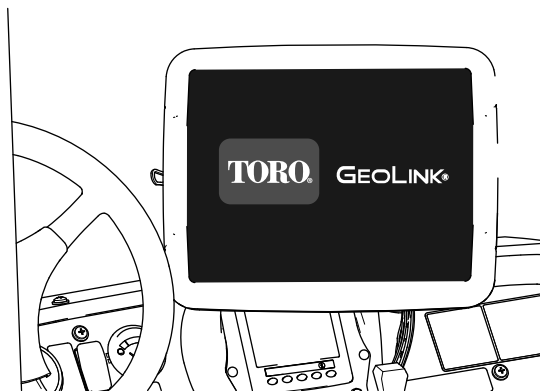

g302921

Figure 155

- Satellite receiver—the PWR indicator illuminates ([Figure 156](#))

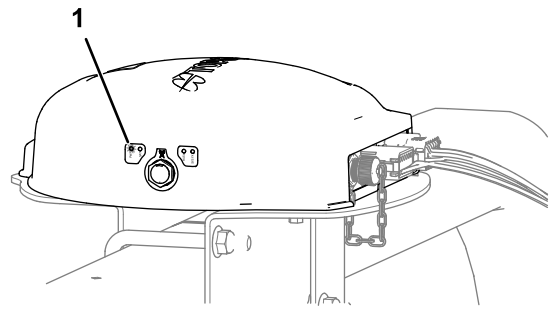

g302922

Figure 156

1. PWR indicator (satellite receiver)

- Automatic section controller—the STATUS indicator illuminates ([Figure 157](#))

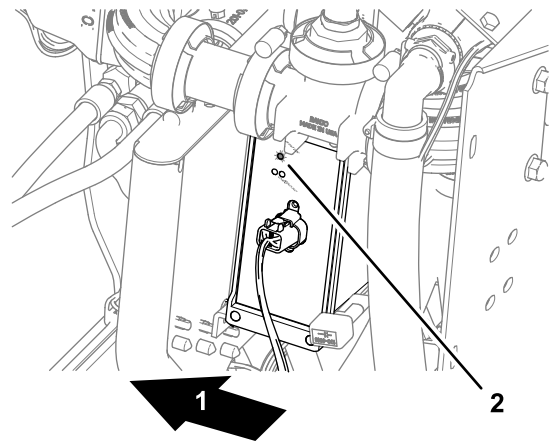

g302923

Figure 157

1. Back of the machine
2. STATUS indicator (automatic section controller)

3. Turn the ignition key to the OFF position.
4. Verify that power is shut off at the following components:
 - Control console
 - Satellite receiver
 - Automatic section controller

27

Verifying the Software Version

No Parts Required

Procedure

1. Turn the ignition key to the RUN(gasoline) or PREHEAT/RUN (diesel) position.
2. Press the ABOUT (Toro) icon at the upper left corner of the control console (Figure 158).

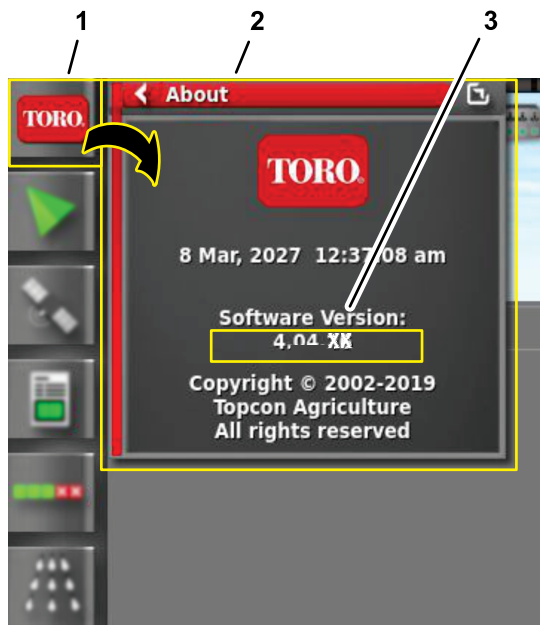

Figure 158

g302935

1. ABOUT (Toro) icon
2. ABOUT fly-out-window
3. Software version number

3. Compare the software version numbers at the following locations:
 - When used, the cover page of the *Software Guide* for your GeoLink system
 - Displayed in the command console

Note: If the software versions differ, contact Toro NSN at 1-844-GEOLINK (1-844-436-5465) or NSNTech@toro.com for customer service.

28

Selecting the Units of Measure

No Parts Required

Procedure

Select the units of measure; refer to the *Operator's Manual* or *Software Guide* for your GeoLink system.

29

Creating a Field

No Parts Required

Procedure

Create a new field; refer to the *Operator's Manual* or *Software Guide* for your GeoLink system.

30

Creating a New Application Rate Product

No Parts Required

Procedure

Create a new product and application rate entry; refer to the *Operator's Manual* or *Software Guide* for your GeoLink system.

31

Creating a Spray Job

No Parts Required

Procedure

1. Press the Job Menu and press the CREATE NEW JOB icon (Figure 159).

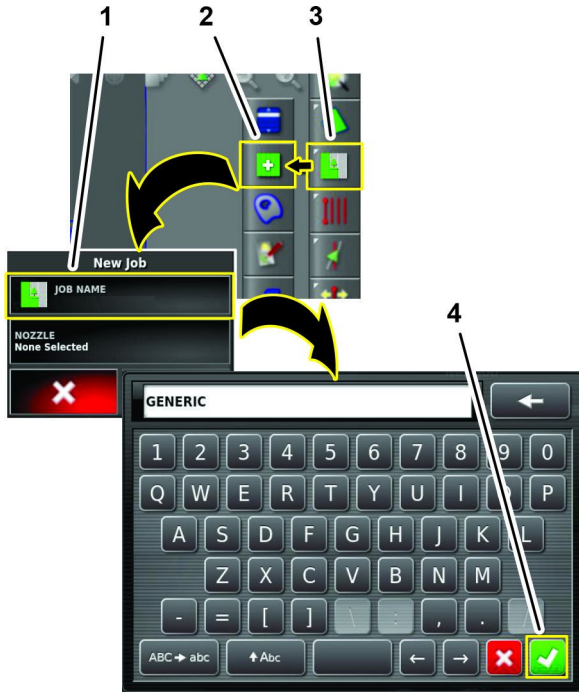

Figure 159

g304037

1. JOB NAME icon
 2. CREATE NEW JOB icon
 3. JOB MENU icon
 4. Confirm icon
-
2. Use on-screen keyboard to type a name for the generic job, and press the confirm icon (Figure 159).
 3. In the new job dialog box, press the NOZZLE icon (Figure 160).



Figure 160

g304039

1. NOZZLE icon
 2. Nozzle selection list icons
 3. Confirm icon
-
4. In the nozzle selection list, press any nozzle icon, and press the confirm icon (Figure 160).
 5. In the new job dialog box, press the confirm icon (Figure 161).



Figure 161

g304038

1. Confirm icon

32

Checking the Spray System

No Parts Required

Procedure

1. Engage the parking brake.
2. Add 200 L (50 US gallon) of water into the spray tank; refer to the *Operator's Manual* for your machine.
3. Start the engine and set the engine speed to fast.
4. On the GeoLink control console, press the SPRAY RATE CONTROLLER icon (Figure 162).

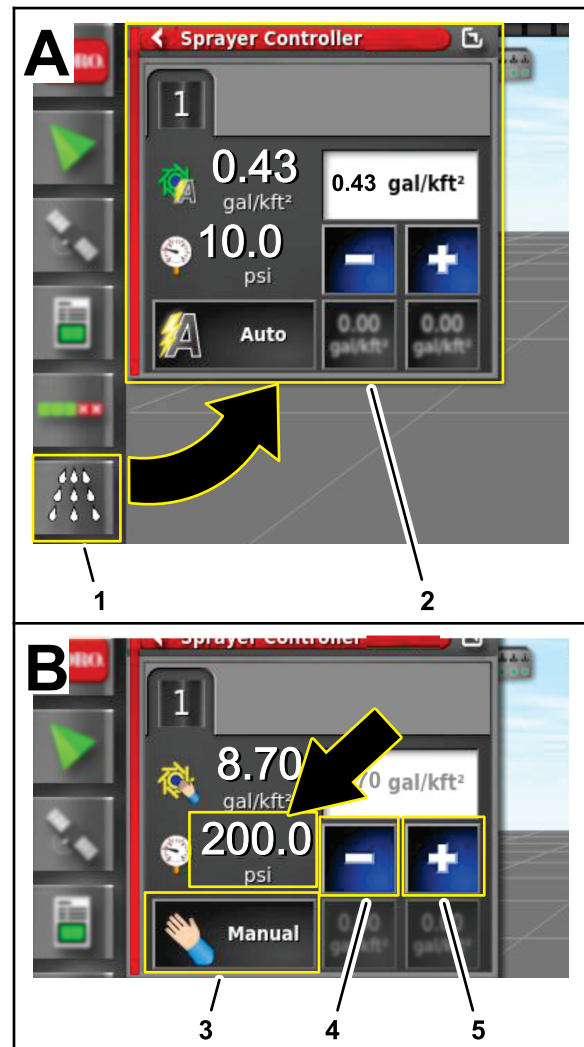

Figure 162

g303612

1. SPRAY RATE CONTROLLER icon
2. Dialog box (spray rate controller)
3. RATE CONTROL MODE icon (manual mode)
4. Decrement icon (-)
5. Increment icon (+)

5. In the spray rate controller dialog box, press the RATE CONTROL MODE icon until manual mode displays (Figure 162).
6. Use the decrement icon (-) or increment icon (+) to adjust the spray system pressure (Figure 162) to 13.75 bar (200 psi).
7. On the machine, press the master-section switch to the ON position (Figure 163).

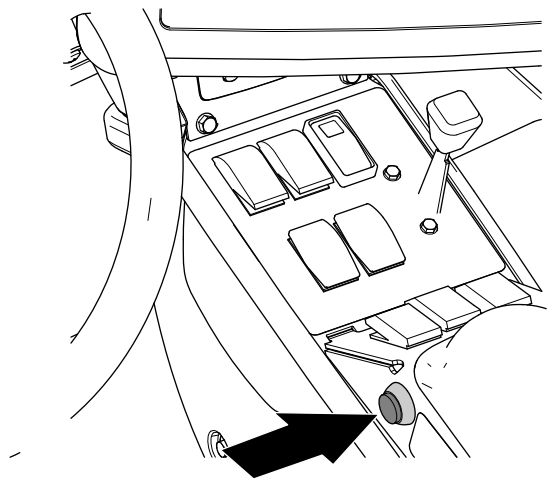

Figure 163

g205127

- On the GeoLink control console, press the MASTER SWITCH icon (Figure 164) to the ON (green).

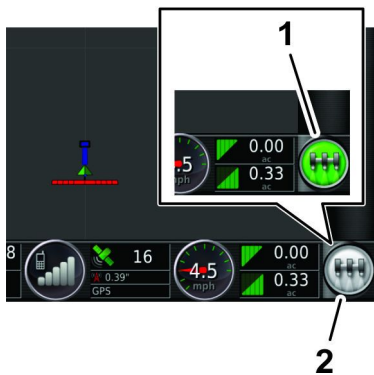

Figure 164

g203807

- Green MASTER SWITCH icon (system ready, sprayer controller on)
- White MASTER SWITCH icon (standby)

- Check all sprayer fittings and components for leaks.

Note: If you find any leaks, shut off the engine and repair the fitting or component.

33

Balancing the Agitation Bypass Valve

No Parts Required

Checking System and Agitation Bypass Pressure

- Engage the parking brake, and start the engine.

Note: Allow the engine and hydraulic system to warm for 10 minutes.
- Ensure that the master section switch to the OFF position.
- Set the spray-pump switch and the tank agitation switch to the ON position.
- Set the left, center, and right section switches to the ON position.
- Set the engine speed to fast.
- On the GeoLink control console, press the SPRAY RATE CONTROLLER icon.
- In the spray rate controller dialog box, press the RATE CONTROL MODE icon until manual mode displays (Figure 165).

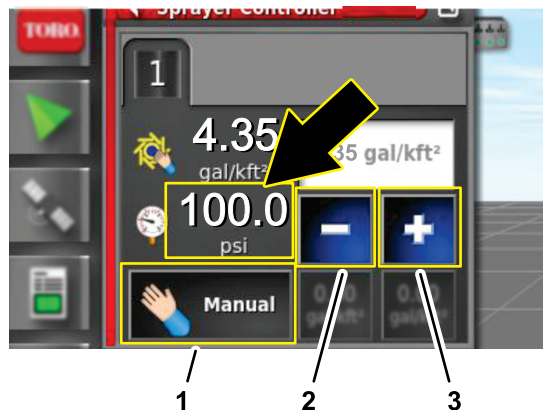

Figure 165

g303643

- RATE CONTROL MODE icon (manual mode)
- Decrement icon (-)
- Increment icon (+)

- Press the decrement icon (-) or increment icon (+) to adjust the spray system pressure (Figure 165) to 6.9 bar (100 psi).
- On the machine, set the tank agitation switch to the OFF position.

- Observe the spray system pressure. If the spray system pressure is 6.9 bar (100 psi), the agitation valve is correctly adjusted.

If the spray system pressure changed, adjust the agitation bypass valve; refer to [Adjusting the Agitation Bypass Valve \(page 74\)](#).

Adjusting the Agitation Bypass Valve

- With the tank agitation switch in the OFF position, walk to the back of the machine and locate the agitation bypass valve.

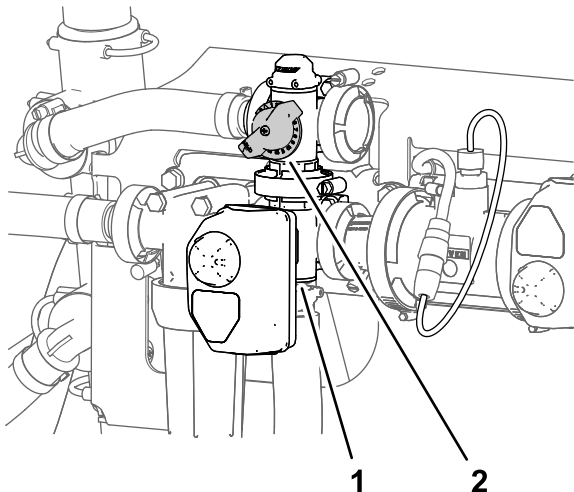

Figure 166

g191362

- Actuator (agitation valve)
- Agitation-bypass valve

- Adjust the agitation-bypass valve ([Figure 166](#)) until the gauge indicates 689 kPa (100 psi) sprayer system pressure.

- Set the tank agitation switch to the ON position and observe the spray system pressure.

Note: If the spray system-pressure gauge indicates greater than or less than 6.9 bar (100 psi), repeat steps 1 and 2.

- Set the tank agitation switch to the OFF position and observe the spray system pressure.

Note: If the spray system-pressure gauge indicates greater than or less than 6.9 bar (100 psi), repeat steps 1 and 2.

34

Performing a Flow Meter Calibration

No Parts Required

Procedure

Calibrate the flow meter; refer to the *Operator's Manual* or *Software Guide* for your GeoLink system.

35

Verifying the Cellular Status

No Parts Required

Procedure

- Move the machine outdoors, away from buildings and power lines.
- Engage the parking brake.
- On the GeoLink control console, press the GPS INFORMATION icon ([Figure 167](#)).

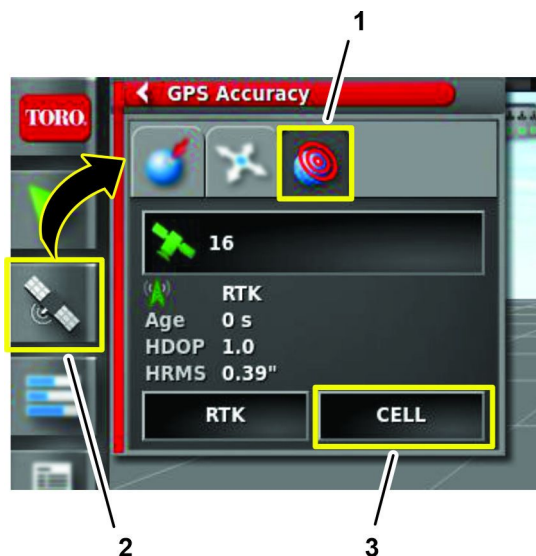

Figure 167

g307927

- GPS ACCURACY icon
- GPS INFORMATION icon
- CELL DIAGNOSTIC icon

- Press the CELL DIAGNOSTIC icon, and verify that the cellular status field displays N-TRIP CONNECTED RECEIVING DATA ([Figure 168](#)).

Note: If the cellular status field displays any message other than N-TRIP CONNECTED RECEIVING DATA, contact Toro NSN at 1-844-GEOLINK (1-844-436-5465) or NSNTech@toro.com for customer service.

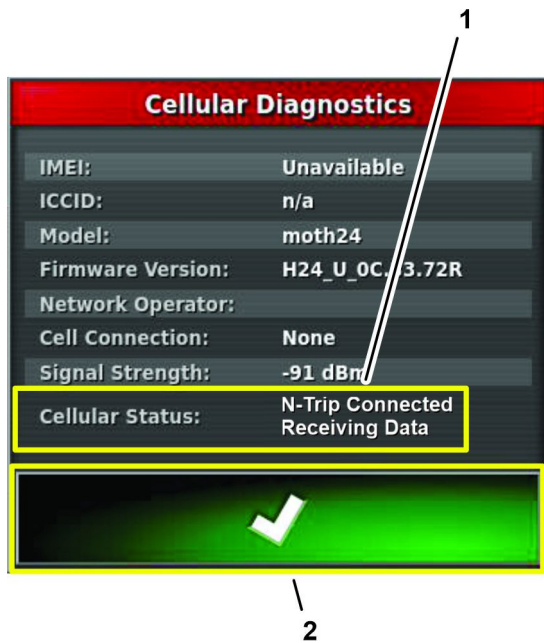

Figure 168

g303849

1. Cellular status field
2. Confirm icon

5. Press the confirm icon to close the dialog box.

36

Performing a Compass Calibration

At the Distributor's Location

No Parts Required

Procedure

Perform a compass calibration at the distributor's location; refer to *Calibrating the Compass* in the *Operator's Manual* or *Software Guide* for your GeoLink system.

37

Performing a Compass Calibration

At the Customer Location

No Parts Required

Procedure

Perform a compass calibration at the customer's location; refer to *Calibrating the Compass* in the *Operator's Manual* or *Software Guide* for your GeoLink system.

Notes:

Notes:

Notes:

European Privacy Notice

The Information Toro Collects

Toro Warranty Company (Toro) respects your privacy. In order to process your warranty claim and contact you in the event of a product recall, we ask you to share certain personal information with us, either directly or through your local Toro company or dealer.

The Toro warranty system is hosted on servers located within the United States where privacy law may not provide the same protection as applies in your country.

BY SHARING YOUR PERSONAL INFORMATION WITH US, YOU ARE CONSENTING TO THE PROCESSING OF YOUR PERSONAL INFORMATION AS DESCRIBED IN THIS PRIVACY NOTICE.

The Way Toro Uses Information

Toro may use your personal information to process warranty claims, to contact you in the event of a product recall and for any other purpose which we tell you about. Toro may share your information with Toro's affiliates, dealers or other business partners in connection with any of these activities. We will not sell your personal information to any other company. We reserve the right to disclose personal information in order to comply with applicable laws and with requests by the appropriate authorities, to operate our systems properly or for our own protection or that of other users.

Retention of your Personal Information

We will keep your personal information as long as we need it for the purposes for which it was originally collected or for other legitimate purposes (such as regulatory compliance), or as required by applicable law.

Toro's Commitment to Security of Your Personal Information

We take reasonable precautions in order to protect the security of your personal information. We also take steps to maintain the accuracy and current status of personal information.

Access and Correction of your Personal Information

If you would like to review or correct your personal information, please contact us by email at legal@toro.com.

Australian Consumer Law

Australian customers will find details relating to the Australian Consumer Law either inside the box or at your local Toro Dealer.



The Toro Warranty

A Two-Year Limited Warranty

Conditions and Products Covered

The Toro Company and its affiliate, Toro Warranty Company, pursuant to an agreement between them, jointly warrant your Toro Commercial product ("Product") to be free from defects in materials or workmanship for two years or 1500 operational hours*, whichever occurs first. This warranty is applicable to all products with the exception of Aerators (refer to separate warranty statements for these products). Where a warrantable condition exists, we will repair the Product at no cost to you including diagnostics, labor, parts, and transportation. This warranty begins on the date the Product is delivered to the original retail purchaser.

* Product equipped with an hour meter.

Instructions for Obtaining Warranty Service

You are responsible for notifying the Commercial Products Distributor or Authorized Commercial Products Dealer from whom you purchased the Product as soon as you believe a warrantable condition exists. If you need help locating a Commercial Products Distributor or Authorized Dealer, or if you have questions regarding your warranty rights or responsibilities, you may contact us at:

Toro Commercial Products Service Department
Toro Warranty Company
8111 Lyndale Avenue South
Bloomington, MN 55420-1196
952-888-8801 or 800-952-2740
E-mail: commercial.warranty@toro.com

Owner Responsibilities

As the Product owner, you are responsible for required maintenance and adjustments stated in your *Operator's Manual*. Failure to perform required maintenance and adjustments can be grounds for disallowing a warranty claim.

Items and Conditions Not Covered

Not all product failures or malfunctions that occur during the warranty period are defects in materials or workmanship. This warranty does not cover the following:

- Product failures which result from the use of non-Toro replacement parts, or from installation and use of add-on, or modified non-Toro branded accessories and products. A separate warranty may be provided by the manufacturer of these items.
- Product failures which result from failure to perform recommended maintenance and/or adjustments. Failure to properly maintain your Toro product per the Recommended Maintenance listed in the *Operator's Manual* can result in claims for warranty being denied.
- Product failures which result from operating the Product in an abusive, negligent, or reckless manner.
- Parts subject to consumption through use unless found to be defective. Examples of parts which are consumed, or used up, during normal Product operation include, but are not limited to, brake pads and linings, clutch linings, blades, reels, rollers and bearings (sealed or greasable), bed knives, spark plugs, castor wheels and bearings, tires, filters, belts, and certain sprayer components such as diaphragms, nozzles, and check valves, etc.
- Failures caused by outside influence. Conditions considered to be outside influence include, but are not limited to, weather, storage practices, contamination, use of unapproved fuels, coolants, lubricants, additives, fertilizers, water, or chemicals, etc.
- Failure or performance issues due to the use of fuels (e.g. gasoline, diesel, or biodiesel) that do not conform to their respective industry standards.

Countries Other than the United States or Canada

Customers who have purchased Toro products exported from the United States or Canada should contact their Toro Distributor (Dealer) to obtain guarantee policies for your country, province, or state. If for any reason you are dissatisfied with your Distributor's service or have difficulty obtaining guarantee information, contact the Toro importer.

- Normal noise, vibration, wear and tear, and deterioration.
- Normal "wear and tear" includes, but is not limited to, damage to seats due to wear or abrasion, worn painted surfaces, scratched decals or windows, etc.

Parts

Parts scheduled for replacement as required maintenance are warranted for the period of time up to the scheduled replacement time for that part. Parts replaced under this warranty are covered for the duration of the original product warranty and become the property of Toro. Toro will make the final decision whether to repair any existing part or assembly or replace it. Toro may use remanufactured parts for warranty repairs.

Deep Cycle and Lithium-Ion Battery Warranty:

Deep cycle and Lithium-Ion batteries have a specified total number of kilowatt-hours they can deliver during their lifetime. Operating, recharging, and maintenance techniques can extend or reduce total battery life. As the batteries in this product are consumed, the amount of useful work between charging intervals will slowly decrease until the battery is completely worn out. Replacement of worn out batteries, due to normal consumption, is the responsibility of the product owner. Battery replacement may be required during the normal product warranty period at owner's expense. Note: (Lithium-Ion battery only): A Lithium-Ion battery has a part only prorated warranty beginning year 3 through year 5 based on the time in service and kilowatt hours used. Refer to the *Operator's Manual* for additional information.

Maintenance is at Owner's Expense

Engine tune-up, lubrication, cleaning and polishing, replacement of filters, coolant, and completing recommended maintenance are some of the normal services Toro products require that are at the owner's expense.

General Conditions

Repair by an Authorized Toro Distributor or Dealer is your sole remedy under this warranty.

Neither The Toro Company nor Toro Warranty Company is liable for indirect, incidental or consequential damages in connection with the use of the Toro Products covered by this warranty, including any cost or expense of providing substitute equipment or service during reasonable periods of malfunction or non-use pending completion of repairs under this warranty. Except for the Emissions warranty referenced below, if applicable, there is no other express warranty. All implied warranties of merchantability and fitness for use are limited to the duration of this express warranty.

Some states do not allow exclusions of incidental or consequential damages, or limitations on how long an implied warranty lasts, so the above exclusions and limitations may not apply to you. This warranty gives you specific legal rights, and you may also have other rights which vary from state to state.

Note regarding engine warranty:

The Emissions Control System on your Product may be covered by a separate warranty meeting requirements established by the U.S. Environmental Protection Agency (EPA) and/or the California Air Resources Board (CARB). The hour limitations set forth above do not apply to the Emissions Control System Warranty. Refer to the Engine Emission Control Warranty Statement supplied with your product or contained in the engine manufacturer's documentation for details