



170-DH Lawn Tractor

74570—200000001 and Up

Operator's Manual



Introduction

Thank you for purchasing a Toro product.

All of us at Toro want you to be completely satisfied with your new product, so feel free to contact your local Authorized Service Dealer for help with service, genuine Toro replacement parts, or other information you may require.

Whenever you contact your Authorized Service Dealer or the factory, always know the model and serial numbers of your product. These numbers will help the Service Dealer or Service Representative provide exact information about your specific product. You will find the model and serial number plate located in a unique place on the product as shown below.

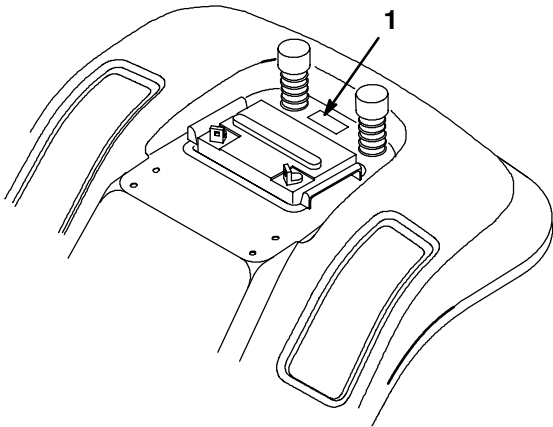

Figure 1

1. Model and Serial Number Plate (under the seat)

For your convenience, write the product model and serial numbers in the space below.

| |
|-------------------------|
| Model No: _____ |
| Serial No. _____ |

Read this manual carefully to learn how to operate and maintain your product correctly. Reading this manual will help you and others avoid personal injury and damage to the product. Although Toro designs, produces and markets safe, state-of-the-art products, you are responsible for using the product properly and safely. You are also responsible for training persons who you allow to use the product about safe operation.

The Toro warning system in this manual identifies potential hazards and has special safety messages that help you and others avoid personal injury, even death. **DANGER**, **WARNING** and **CAUTION** are signal words used to identify the level of hazard. However, regardless of the hazard, be extremely careful.

DANGER signals an extreme hazard that will cause serious injury or death if the recommended precautions are not followed.

WARNING signals a hazard that may cause serious injury or death if the recommended precautions are not followed.

CAUTION signals a hazard that may cause minor or moderate injury if the recommended precautions are not followed.

Two other words are also used to highlight information. “Important” calls attention to special mechanical information and “Note” emphasizes general information worthy of special attention.

The left and right side of the machine is determined by sitting on the seat in the normal operator’s position.

IMPORTANT: The engine in this product is not equipped with a spark arrester muffler. In some areas it is in violation of the law to use or operate this engine on any forest-covered, brush-covered, or grass-covered land.

Contents

| | Page | | Page |
|---|-------------|---|-------------|
| Safety | 2 | Testing the Safety System | 18 |
| Safe Operation Practices for Ride-on (riding) Rotary Lawnmower Machines .. | 2 | Pushing the Machine by Hand | 19 |
| Safe Operating Practices | 2 | Driving Forward or Backward | 19 |
| Toro Riding Mower Safety | 4 | Stopping the Machine | 20 |
| Sound Pressure Level | 5 | Emptying the Grass Collector | 20 |
| Sound Power Level | 5 | Towing Attachments | 20 |
| Vibration Level | 5 | Tips for Mowing Grass | 21 |
| Slope Chart | 7 | Maintenance | 22 |
| Safety Instructions and Decals | 9 | Service Interval Chart | 22 |
| Gasoline and Oil | 11 | Greasing and Lubrication | 23 |
| Recommended Gasoline | 11 | Tire Pressure | 25 |
| Stabilizer/Conditioner | 12 | Brake | 25 |
| Filling the Fuel Tank | 12 | Fuse | 26 |
| Check Engine Oil Level | 12 | Headlights | 26 |
| Operation | 13 | Battery | 27 |
| Think Safety First | 13 | Spark Plug | 29 |
| Controls | 13 | Fuel Tank | 30 |
| Parking Brake | 13 | Fuel Filter | 31 |
| Positioning the Seat | 14 | Air Cleaner | 31 |
| Headlights | 14 | Engine Oil | 33 |
| Using the Blade Control (PTO) | 14 | Cutting Blade | 35 |
| Grass Collector Warning Light | 14 | Removing the Mower | 37 |
| Setting the Height-of-Cut | 15 | Installing the Mower | 37 |
| Discharge Baffle | 15 | Adjusting the Blade Drive Belt | 38 |
| Adjusting Mower Gauge Wheels | 15 | Adjusting the Height Adjustment Cable Rod Assembly | 38 |
| Starting and Stopping the Engine | 16 | Grass Collector | 39 |
| The Safety Interlock System | 17 | Cleaning and Storage | 39 |
| Operating-in-Reverse | 17 | Troubleshooting | 41 |

Safety

Safe Operation Practices for Ride-on (riding) Rotary Lawnmower Machines

This machine meets or exceeds European Standards in effect at the time of production. However, improper use or maintenance by the operator or owner can result in injury. To reduce the potential for injury, comply with these safety instructions and always pay attention to the safety alert ▲ symbol, which means CAUTION, WARNING, or DANGER—“personal safety instruction.” Failure to comply with the instruction may result in personal injury or death.

Safe Operating Practices

The following instructions are from the CEN standard EN 836:1997.

This product is capable of amputating hands and feet and throwing objects. Always follow all safety instructions to avoid serious injury or death.

Training

- Read the instructions carefully. Be familiar with the controls and the proper use of the equipment.
- Never allow children or people unfamiliar with these instructions to use the lawnmower. Local regulations can restrict the age of the operator.
- Never mow while people, especially children, or pets are nearby.
- Keep in mind that the operator or user is responsible for accidents or hazards occurring to other people or their property.
- Do not carry passengers.

- All drivers should seek and obtain professional and practical instruction. Such instruction should emphasize:
 - the need for care and concentration when working with ride-on machines;
 - control of a ride-on machine sliding on a slope will not be regained by the application of the brake. The main reasons for loss of control are:
 - insufficient wheel grip;
 - being driven too fast;
 - inadequate braking;
 - the type of machine is unsuitable for its task;
 - lack of awareness of the effect of ground conditions, especially slopes;
 - incorrect hitching and load distribution.

Preparation

- While mowing, always wear substantial footwear and long trousers. Do not operate the equipment when barefoot or wearing open sandals.
- Thoroughly inspect the area where the equipment is to be used and remove all objects which may be thrown by the machine.
- **WARNING - Fuel is highly flammable.**
 - Store fuel in containers specifically designed for this purpose.
 - Refuel outdoors only and do not smoke while refuelling.

- Add fuel before starting the engine. Never remove the cap of the fuel tank or add fuel while the engine is running or when the engine is hot.
- If fuel is spilled, do not attempt to start the engine but move the machine away from the area of spillage and avoid creating any source of ignition until fuel vapors have dissipated.
- Replace all fuel tanks and container caps securely.
- Replace faulty silencers.
- Before using, always visually inspect to see that the blades, blade bolts and cutter assembly are not worn or damaged. Replace worn or damaged blades and bolts in sets to preserve balance.
- On multi-bladed machines, take care as rotating one blade can cause other blades to rotate.
- engage clutch slowly, always keep machine in gear, especially when travelling downhill;
- machine speeds should be kept low on slopes and during tight turns;
- stay alert for humps and hollows and other hidden hazards;
- never mow across the face of the slope, unless the lawnmower is designed for this purpose.
- Use care when pulling loads or using heavy equipment.
- Use only approved drawbar hitch points.
- Limit loads to those you can safely control.
- Do not turn sharply. Use care when reversing.
- Use counterweight(s) or wheel weights when suggested in the instruction handbook.
- Watch out for traffic when crossing or near roadways.
- Stop the blades rotating before crossing surfaces other than grass.
- When using any attachments, never direct discharge of material toward bystanders nor allow anyone near the machine while in operation.
- Never operate the machine with defective guards or without safety protective devices in place.
- Do not change the engine governor settings or overspeed the engine. Operating the engine at excessive speed can increase the hazard of personal injury.
- Before leaving the operator's position:
 - disengage the power take-off and lower the attachments;

Operation

- Do not operate the engine in a confined space where dangerous carbon monoxide fumes can collect.
- Mow only in daylight or in good artificial light.
- Before attempting to start the engine, disengage all blade attachment clutches and shift into neutral.
- Do not use on slopes of more than
 - 5° when mowing on side hills;
 - 10° when mowing uphill;
 - 15° when mowing downhill.
- Remember there is no such thing as a "safe" slope. Travel on grass slopes requires particular care. To guard against overturning:
 - do not stop or start suddenly when going up or downhill;

- change into neutral and set the parking brake;
- stop the engine and remove the key.
- Disengage drive to attachments, stop the engine, and disconnect the spark plug wire(s) or remove the ignition key
 - before clearing blockages or unclogging chute;
 - before checking, cleaning or working on the lawnmower;
 - after striking a foreign object. Inspect the lawnmower for damage and make repairs before restarting and operating the equipment;
 - if the machine starts to vibrate abnormally (check immediately).
- Disengage drive to attachments when transporting or not in use.
- Stop the engine and disengage drive to attachment
 - before refuelling;
 - before removing the grass catcher;
 - before making height adjustment unless adjustment can be made from the operator's position.
- Reduce the throttle setting during engine run-out and, if the engine is provided with a shut-off valve, turn the fuel off at the conclusion of mowing.
- Allow the engine to cool before storing in any enclosure.
- To reduce the fire hazard, keep the engine, silencer, battery compartment and fuel storage area free of grass, leaves, or excessive grease.
- Check the grass catcher frequently for wear or deterioration.
- Replace worn or damaged parts for safety.
- If the fuel tank has to be drained, this should be done outdoors.
- On multi-bladed machines, take care as rotating one blade can cause other blades to rotate.
- When machine is to be parked, stored or left unattended, lower the cutting means unless a positive mechanical lock is used.

Toro Riding Mower Safety

The following list contains safety information specific to Toro products or other safety information that you must know that is not included in the CEN standard.

- Use only Toro-approved attachments. Warranty may be voided if used with unapproved attachments.

Maintenance and Storage

- Keep all nuts, bolts and screws tight to be sure the equipment is in safe working condition.
- Never store the equipment with fuel in the tank inside a building where fumes can reach an open flame or spark.

Sound Pressure Level

This unit has an equivalent continuous A-weighted sound pressure at the operator ear of: 79 dBA, based on measurements of identical machines per Directive 84/538/EEC.

Sound Power Level

This unit has a sound power level of: 100 Lwa, based on measurements of identical machines per procedures outlined in Directive 84/538/EEC and amendments.

Vibration Level

This unit has a maximum hand-arm vibration level of 3.59 m/s^2 and whole body vibration level of 1.13 m/s^2 , based on measurements of identical machines per EN 1033 and EN 1032.

Slope Chart

Read all safety instructions on pages 2-8.

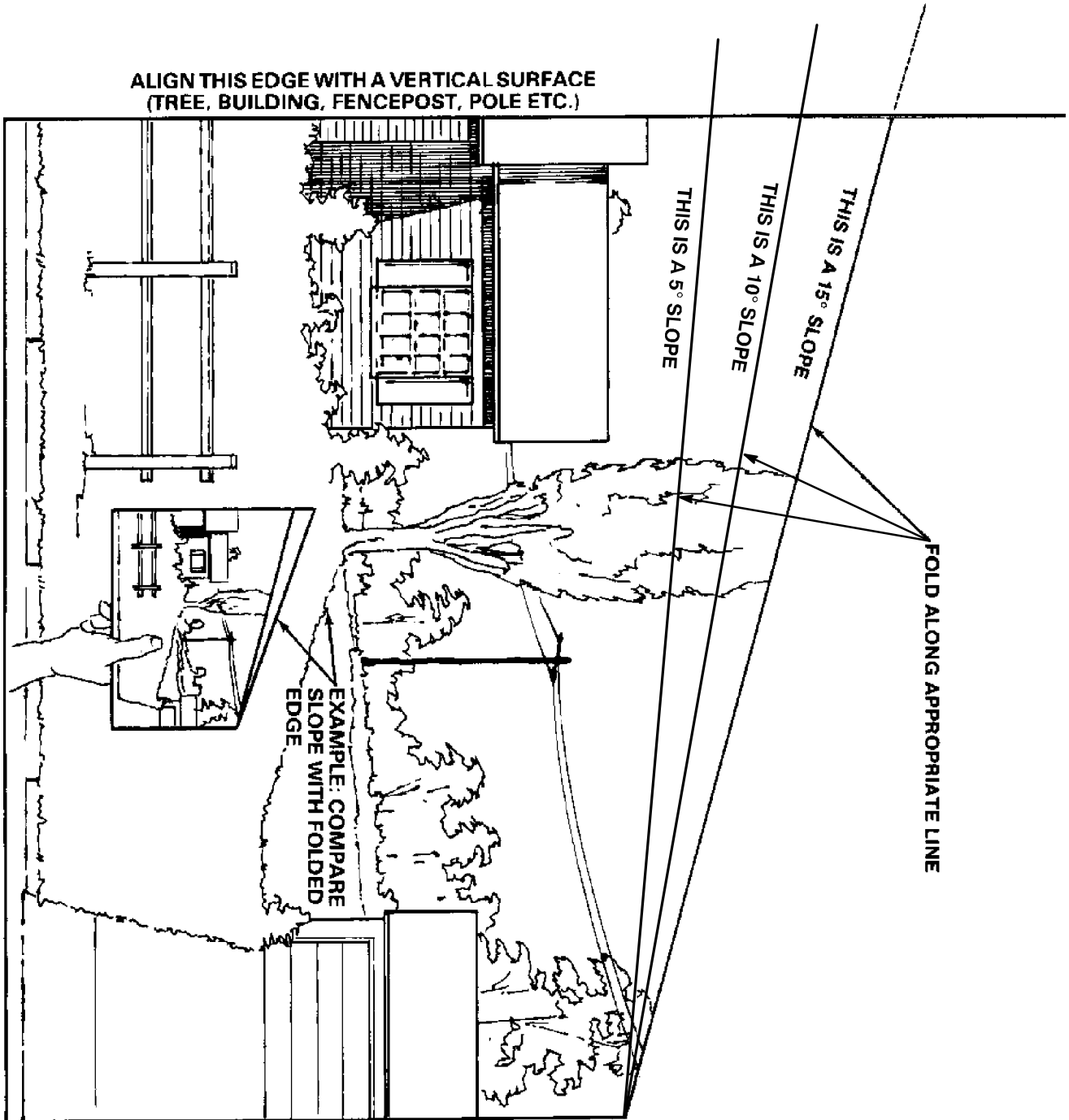

Safety Instructions and Decals

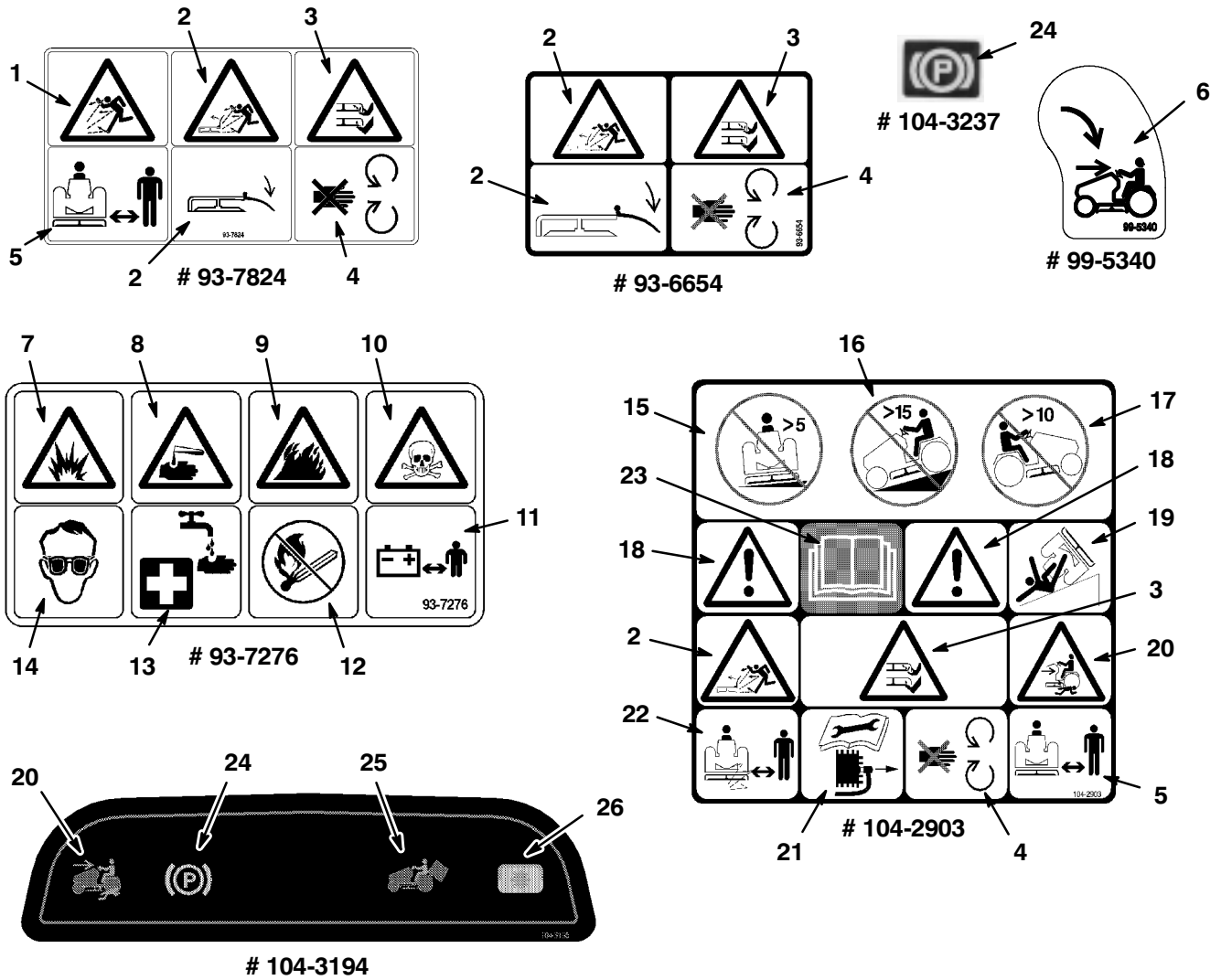
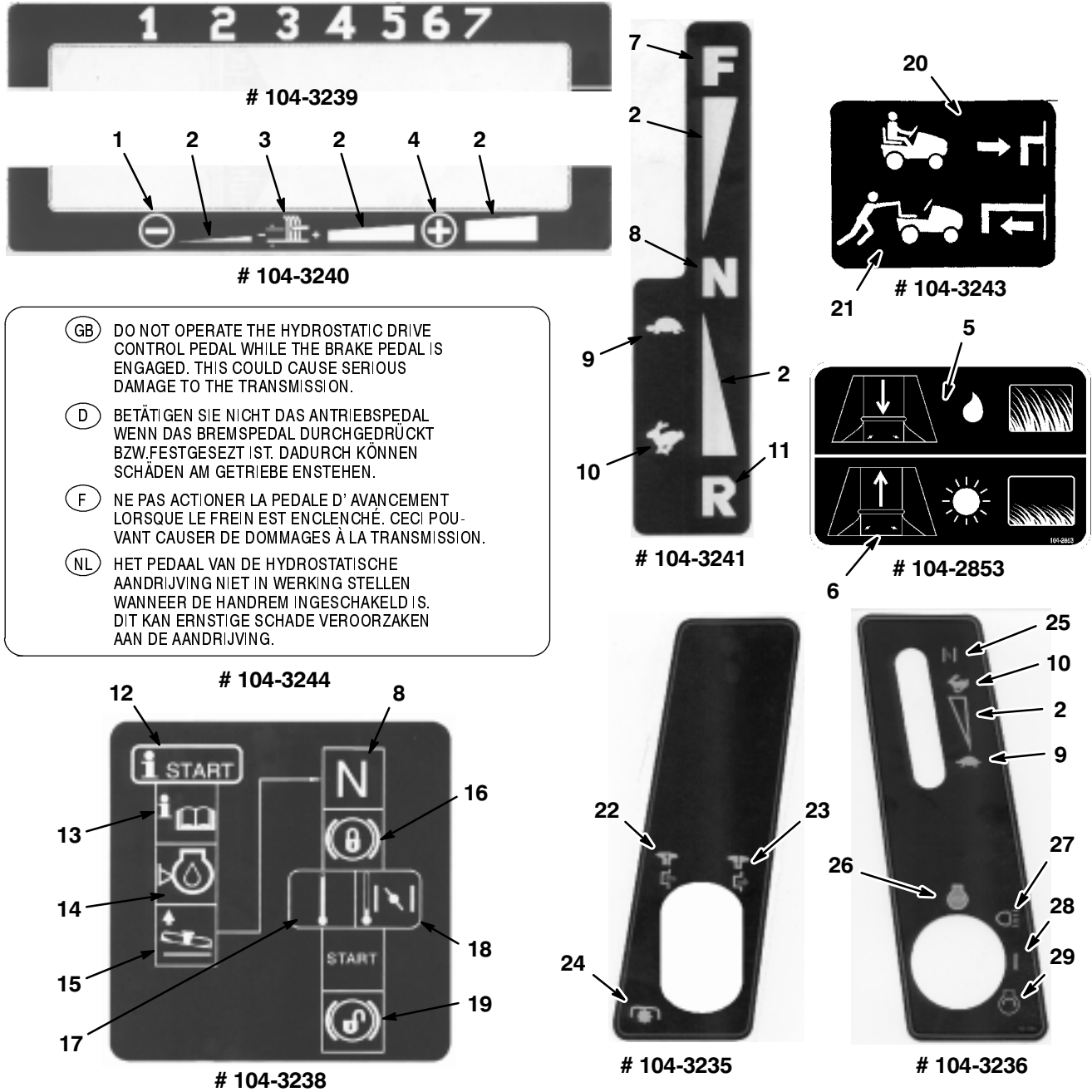

Figure 2

- | | | | |
|---|--|---|---|
| <ol style="list-style-type: none"> 1. Thrown or flying objects, whole body exposure 2. Thrown or flying objects, rotary mower 3. Severing of toes or fingers, mower blade 4. Do not open or remove safety shields while the engine is running. 5. Stay a safe distance from the machine. 6. Key Choice Switch | <ol style="list-style-type: none"> 7. Explosive hazard 8. Caustic liquids, chemical burns to fingers or hand 9. Fire or open flame 10. Caution, toxic risk 11. Keep children a safe distance from the battery 12. Fire, open light, and smoking prohibited 13. First aid, flush with water 14. Eye protection must be worn | <ol style="list-style-type: none"> 15. Machine rollover. Do not use the machine on a side hill slope greater than 5 degrees. 16. Machine rollover. Do not use the machine on a downhill slope greater than 15 degrees. 17. Machine rollover. Do not use the machine on an uphill slope greater than 10 degrees. 18. Failure/Malfunction 19. Machine rollover, riding mower | <ol style="list-style-type: none"> 20. Dismemberment, front engine mower in rearward motion 21. Remove the spark plug, read technical manual 22. Thrown or flying objects. Stay a safe distance from the machine. 23. Read the operator's manual 24. Parking brake 25. Full grass bag indicator 26. PTO (Power Take Off) |
|---|--|---|---|



(GB) DO NOT OPERATE THE HYDROSTATIC DRIVE CONTROL PEDAL WHILE THE BRAKE PEDAL IS ENGAGED. THIS COULD CAUSE SERIOUS DAMAGE TO THE TRANSMISSION.

(D) BETÄTIGEN SIE NICHT DAS ANTRIEBSPEDAL WENN DAS BREMSPEDAL DURCHGEDRÜCKT BZW. FESTGESETZT IST. DADURCH KÖNNEN SCHÄDEN AM GETRIEBE ENSTEHEN.

(F) NE PAS ACTIONNER LA PÉDALE D'AVANCEMENT LORSQUE LE FREIN EST ENCLENCHÉ. CECI POURRAIT CAUSER DE DOMMAGES À LA TRANSMISSION.

(NL) HET PEDAAL VAN DE HYDROSTATISCHE AANDRIJVING NIET IN WERKING STELLEN WANNEER DE HANDREM INGESCHAKELD IS. DIT KAN ERNSTIGE SCHADE VEROORZAKEN AAN DE AANDRIJVING.

Figure 3

- | | | | |
|--|---|---|----------------------------|
| 1. Decrease | 6. Decrease the discharge opening when mowing short, dry grass. | 13. Read the operator's manual for instructions | 21. Pull out to push mower |
| 2. Continuous variable, linear | 7. Forward | 14. Engine oil level | 22. Pull up to engage |
| 3. Blade cutting element—height adjustment | 8. Neutral | 15. Raise the cutting unit | 23. Push in to disengage |
| 4. Increase | 9. Slow | 16. Lock the brake system | 24. Power Take Off (PTO) |
| 5. Increase the discharge opening when mowing long, wet grass. | 10. Fast | 17. High temperature | 25. Choke |
| | 11. Reverse | 18. Low temperature, choke | 26. Engine stop |
| | 12. Starting instructions | 19. Unlock the brake system | 27. Headlights |
| | | 20. Push in to drive mower | 28. On/Start |
| | | | 29. Engine start |

Gasoline and Oil

Recommended Gasoline

Use UNLEADED Regular Gasoline suitable for automotive use (85 pump octane minimum). Leaded regular gasoline may be used if unleaded regular is not available.

IMPORTANT: Never use methanol, gasoline containing methanol, or gasohol containing more than 10% ethanol because the fuel system could be damaged. Do not mix oil with gasoline.

DANGER

POTENTIAL HAZARD

- In certain conditions gasoline is extremely flammable and highly explosive.

WHAT CAN HAPPEN

- A fire or explosion from gasoline can burn you, others, and cause property damage.

HOW TO AVOID THE HAZARD

- Use a funnel and fill the fuel tank outdoors, in an open area, when the engine is cold. Wipe up any gasoline that spills.
- Do not fill the fuel tank completely full. Add gasoline to the fuel tank until the level is 1/4" to 1/2" (6 mm to 13 mm) below the bottom of the filler neck. This empty space in the tank allows gasoline to expand.
- Never smoke when handling gasoline, and stay away from an open flame or where gasoline fumes may be ignited by a spark.
- Store gasoline in an approved container and keep it out of the reach of children. Never buy more than a 30-day supply of gasoline.

DANGER

POTENTIAL HAZARD

- In certain conditions gasoline is extremely flammable and highly explosive.

WHAT CAN HAPPEN

- A fire or explosion from gasoline can burn you, others, and cause property damage.

HOW TO AVOID THE HAZARD

- Always place gasoline containers on the ground away from your vehicle before filling.
- Do not fill gasoline containers inside a vehicle or on a truck or trailer bed because interior carpets or plastic truck bed liners may insulate the container and slow the loss of any static charge.
- When practical, remove gas-powered equipment from the truck or trailer and refuel the equipment with its wheels on the ground.
- If this is not possible, then refuel such equipment on a truck or trailer from a portable container, rather than from a gasoline dispenser nozzle.
- If a gasoline dispenser nozzle must be used, keep the nozzle in contact with the rim of the fuel tank or container opening at all times until fueling is complete.

Stabilizer/Conditioner

Using a stabilizer/conditioner in the machine:

- Keeps gasoline fresh during storage of 90 days or less. For longer storage it is recommended that the fuel tank be drained.
- Cleans the engine while it runs
- Eliminates gum-like varnish buildup in the fuel system, which causes hard starting

IMPORTANT: Never use fuel additives containing methanol or ethanol.

Add the correct amount of gas stabilizer/conditioner to the gas.

Note: A fuel stabilizer/conditioner is most effective when mixed with fresh gasoline. To minimize the chance of varnish deposits in the fuel system, use fuel stabilizer at all times.

Filling the Fuel Tank

1. Shut the engine off and set the parking brake. Allow engine to cool for two minutes.
2. Clean around fuel tank cap and remove the cap. Add unleaded regular gasoline to fuel tank, until the level is 6 mm to 13 mm (1/4 to 1/2 inch) below the bottom of the filler neck. This space in the tank allows gasoline to expand. Do not fill the fuel tank completely full.
3. Install fuel tank cap securely. Wipe up any gasoline that may have spilled.

Check Engine Oil Level

Before you start the engine and use the machine, check the oil level in the engine crankcase; refer to Checking Oil Level, page 33.

Operation

Think Safety First

Please carefully read all the safety instructions and symbols in the safety section. Knowing this information could help you, your family, pets or bystanders avoid injury.

Controls

Become familiar with all the controls (Fig. 1) before you start the engine and operate the machine.

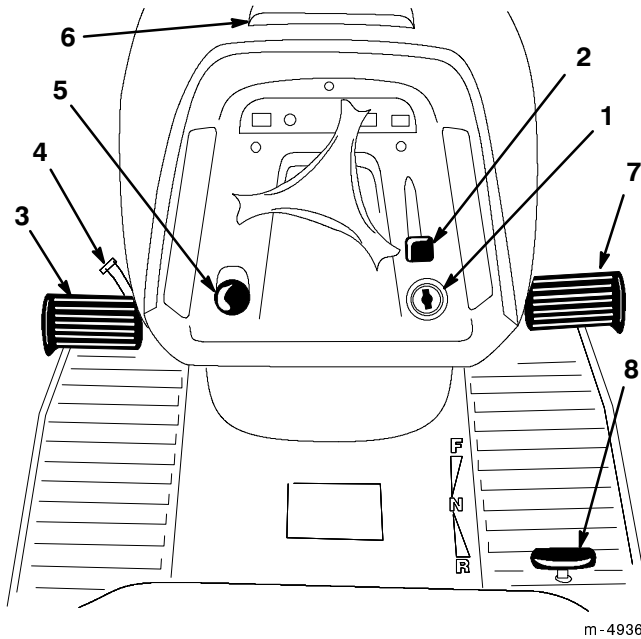

Figure 1

- | | |
|--------------------------|------------------------|
| 1. Ignition/light switch | 5. Blade control (PTO) |
| 2. Throttle/choke lever | 6. Hood opening |
| 3. Brake pedal | 7. Forward speed pedal |
| 4. Parking brake lever | 8. Reverse speed pedal |

Parking Brake

Always set the parking brake when you stop the machine or leave it unattended.

Setting the Parking Brake

1. Push the brake pedal (Fig. 1) down and hold it in the depressed position.
2. Turn the parking brake lever (Fig. 1) counterclockwise and gradually take your foot off the brake pedal. The brake pedal should stay in the depressed (locked) position.

Note: The parking brake light on the dash will turn on when the parking brake is engaged (Fig. 4).

Releasing the Parking Brake

1. Push down on the brake pedal (Fig. 1). The parking brake lever should release.
2. Gradually release the brake pedal.

Positioning the Seat

The seat can move forward and backward. Position the seat where you have the best control of the machine and are most comfortable.

1. Raise the seat and loosen the adjustment knobs (Fig. 2).
2. Move the seat to the desired position and tighten the adjustment knobs.

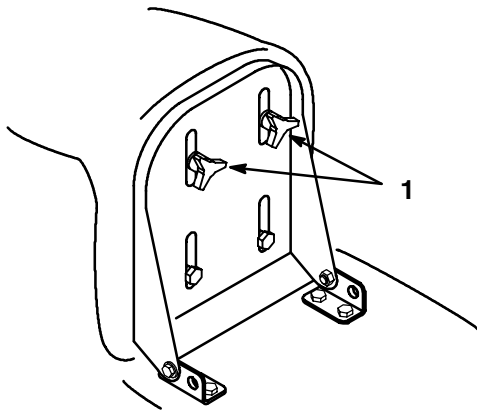

Figure 2

1. Adjustment knobs

m-4841

Headlights

The headlights are an integral function of the ignition switch. Turn the ignition key clockwise to the “LIGHTS” position.

Using the Blade Control (PTO)

The blade control (PTO) engages and disengages power to the blade(s).

Engaging the Blade(s)

1. Depress the brake pedal to stop the machine.

2. Pull the blade control (PTO) out to “ENGAGED” (Fig. 3).

Note: The PTO light on the dash will turn on when the PTO is engaged (Fig. 4).

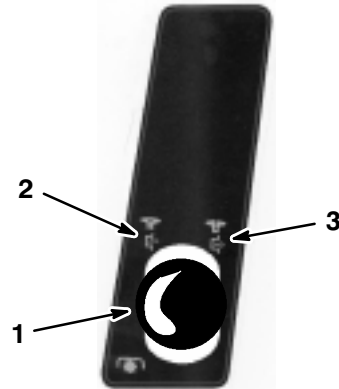

Figure 3

1. Blade control (PTO)
2. Engaged
3. Disengaged

Disengaging the Blade(s)

1. Depress the brake pedal to stop the machine.
2. Push the blade control (PTO) in to “DISENGAGED” (Fig. 3).

Grass Collector Warning Light

When the grass collector is full and needs to be emptied, the warning light will come on (Fig. 4) and a buzzer will sound.

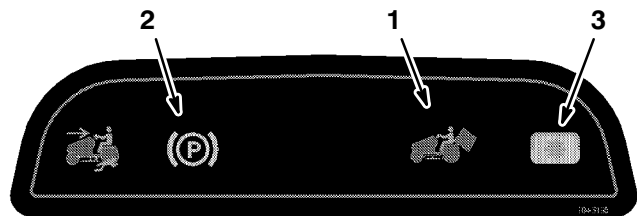

Figure 4

1. Grass collector warning light
2. Parking brake light
3. PTO light

IMPORTANT: To prevent the discharge tunnel from getting clogged, disengage the blade control (PTO) when the warning light and buzzer are activated.

Setting the Height-of-Cut

The height-of-cut lever (deck lift) is used to raise and lower the mower to the desired cutting height.

1. The cutting height may be set in one of seven positions from approximately 25 to 102 mm (1 to 4 inches).
2. Pull or push the height-of-cut lever (deck lift) and move it to the desired position (Fig. 5).

IMPORTANT: The height-of-cut lever must be in the highest position (7) when you are in transport mode (off the lawn) to prevent damage to the cutting blades.

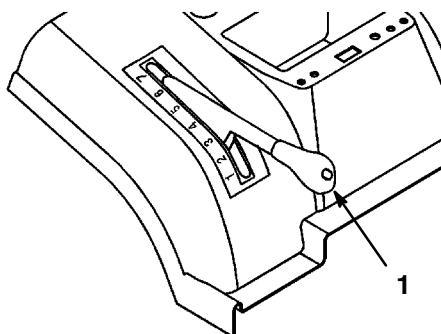

Figure 5

1. Height-of-cut lever (deck lift)

Discharge Baffle

The discharge baffle changes the size of the discharge opening to aid the bag fill indicator operation.

1. Remove the grass collector; refer to Removing the Grass Collector, page 39.

2. Loosen the (2) nuts on the mowing conditions plate and slide the plate up if you are mowing short, dry grass or down if you are mowing long, wet grass (Fig. 6). Tighten the nuts.
3. Install the grass collector; refer to Installing the Grass Collector, page 39.

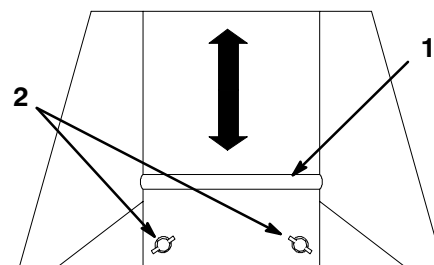

m-4934

Figure 6

1. Plate
2. Nuts

Adjusting Mower Gauge Wheels

The mower front gauge wheels are used to guide the mower over uneven ground. The mower wheels must always be in the bottom (lowest) hole in wheel bracket (Fig. 7).

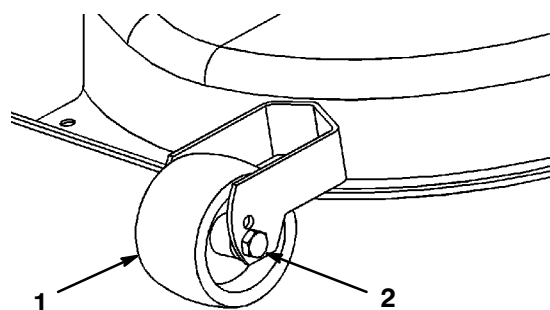

Figure 7

1. Wheel
2. Bottom hole

Starting and Stopping the Engine

Starting

1. Open the fuel shut-off valve (Fig. 8) located between the fuel tank and the engine. The handle should align with the fuel hose.

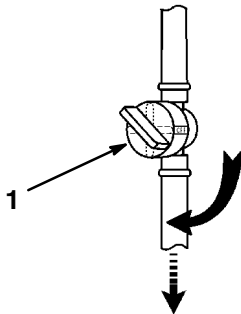

Figure 8

1. Fuel shut-off valve

2. Sit down on the seat.
3. Set the parking brake; refer to Setting the Parking Brake, page 13.

Note: The engine will not start unless you set the parking brake or fully depress the brake pedal.

4. Ensure the PTO is disengaged (Fig. 9).
5. When starting a cold engine move the throttle lever to the “CHOKE” position (Fig. 10).

Note: To start a warm engine, move the throttle lever to the “FAST” position.

6. Turn the ignition key clockwise and hold it in the “START” position (Fig. 10). When the engine starts, release the key.

IMPORTANT: If the engine does not start after 15 seconds of continuous cranking, turn the ignition key to “OFF” and let the starter motor cool for two minutes; refer to Troubleshooting, page 41.

7. After the engine starts, slowly move the throttle to FAST (Fig. 10).

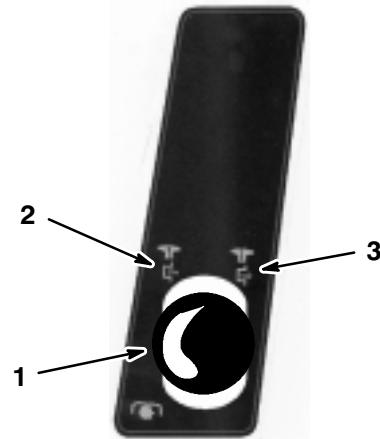

Figure 9

1. Blade control (PTO)
2. Engaged
3. Disengaged

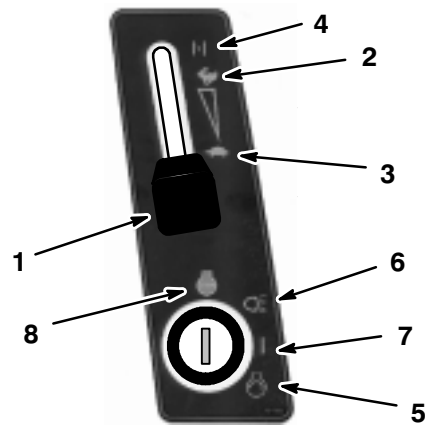

Figure 10

1. Throttle control
2. Fast
3. Slow
4. Choke
5. Start
6. Lights
7. On
8. Off

Stopping

1. Move the throttle lever to SLOW (Fig. 10).

IMPORTANT: To prevent backfiring and damage to the engine, do not move the throttle lever to CHOKE or FAST to stop the engine.

2. Turn the ignition key to OFF (Fig. 10).

Note: If the engine has been working hard or is hot, let it idle for a minute before turning the ignition key “OFF.” This helps cool the engine before it is stopped. In an emergency, the engine may be stopped by turning the ignition key to “OFF.”

The Safety Interlock System

Understanding the Safety Interlock System

The safety interlock system is designed to prevent the engine from starting unless:

- You are sitting on the seat;
- The brake pedal is depressed;
- The blade control (power take off/PTO) is “DISENGAGED.”

The safety interlock system is designed to stop the engine if:

- You rise from the seat.

The safety interlock system is designed to stop the mower deck if:

- You shift into reverse with the blade control (PTO) engaged;
- You remove the bag or dump grass.

Operating-in-Reverse

An interlock feature is provided that prevents the Power Take Off (PTO) from operating while the tractor is traveling in reverse. If the unit is shifted into reverse while the mower blade or other PTO driven attachment is engaged, the PTO will stop.

Do not mow while backing up unless it is absolutely necessary. If you need to mow while in reverse gear, this no operating-in-reverse interlock may be temporarily deactivated.

Before deactivating this interlock, be sure there are no children present on or near the property where you are using the tractor, and that none are likely to appear while you are mowing or operating an attachment. Be extra observant after you have chosen to deactivate the interlock because the sound of the tractor’s engine might prevent you from being aware that a child or a bystander has entered the area where you are operating the tractor.

If you are certain that you can safely mow in reverse or operate an attachment, deactivate the no operating-in-reverse interlock by turning the Key Choice™ switch (Fig. 11), located on the seat bracket on the right hand side just below the seat, after engaging the blade (PTO). A red light on the front console (Fig. 12) will turn on as a reminder that the no operating-in-reverse interlock has been deactivated. Once the interlock is deactivated it stays in this mode—with your mower blade operating whenever you back up—and the console light stays on until either the blade (PTO) is disengaged, or the engine is turned off.

Note: Do not insert the “Key Choice” key unless it is absolutely necessary to mow in reverse. The “Key Choice” key should also be removed from the unit if it will be operated by someone other than a responsible, experienced operator. This will prevent the unit from operating in reverse with the mower blade or other PTO attachment engaged. Always remove both the ignition and the “Key Choice” keys

and put them in a safe place out of the reach of children when leaving the unit unattended.

! DANGER

POTENTIAL HAZARD

- A child or bystander could be backed over by a riding mower with its blade(s) engaged.

WHAT CAN HAPPEN

- Blade contact will cause serious personal injury or death.

HOW TO AVOID THE HAZARD

- Do not mow in reverse unless absolutely necessary.
- Always look backward and down before backing up.
- Use “Key Choice” switch only if you are certain no children or other bystanders will appear in the mowing area.
- Always remove both the ignition and “Key Choice” keys and put them in a safe place out of the reach of children or unauthorized users when leaving the unit unattended.

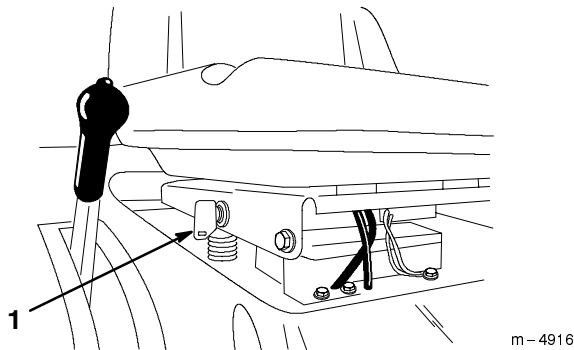

Figure 11

1. “Key Choice” switch

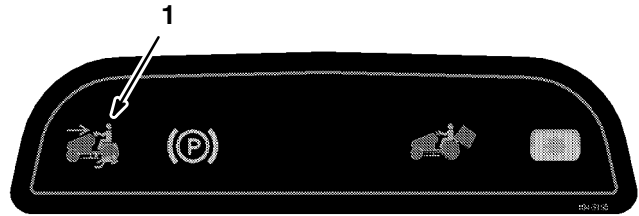

Figure 12

1. Operating-in-Reverse light

Testing the Safety System

Test the safety system before you use the machine each time. If the safety system does not operate as described below, have an Authorized Service Dealer repair the safety system immediately. While setting in the seat, perform the following checks.

1. Set the parking brake. Move the blade control (PTO) to “ENGAGED.” Now turn the ignition key to “START”; the engine should not crank.
2. Move the blade control (PTO) to “DISENGAGED” and release the parking brake. Now turn the ignition key to “START”; the engine should not crank.
3. Set the parking brake and move the PTO to “DISENGAGED.” Now start the engine. While the engine is running, release the parking brake and rise slightly from the seat; the engine should stop.
4. Move the PTO to “DISENGAGED” and put the foot pedal in neutral. Start the engine. While the engine is running, move the PTO to “ENGAGED” and the foot pedal to reverse. The mower deck should stop.
5. Move the PTO to “DISENGAGED” and put the foot pedal in neutral. Now start the engine. Move the PTO to “ENGAGED” and turn the “Key Choice” key and release. The operating-in-reverse warning light should illuminate. Move the PTO to “DISENGAGED” and the operating-in-reverse warning light should turn off.

Pushing the Machine by Hand

IMPORTANT: Always push the machine by hand. Never tow the machine because transaxle damage may occur.

To Push the Machine

1. Park the machine on a level surface, disengage the PTO, set the parking brake, stop the engine, and remove the ignition key.
2. Remove the grass collector; refer to Removing the Grass Collector, page 39.
3. Pull the drive control, located at the rear of the machine, out to the “PUSH” position and release the parking brake. This disengages the drive system and allows the wheels to turn freely (Fig. 13).

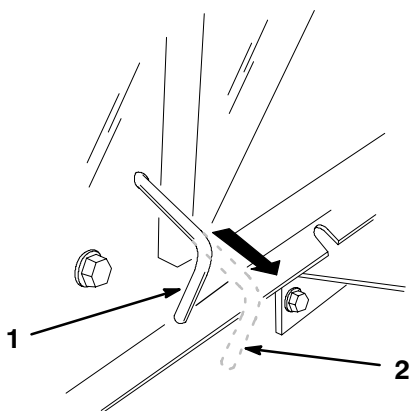

m-4933

Figure 13

1. Operate position 2. Push position

To Operate the Machine

1. Set the parking brake and push the drive control in to the “OPERATE” position. This engages the drive system (Fig. 13).

Note: The machine will not drive unless the drive control is in the “OPERATE” position.

2. Install the grass collector; refer to Installing the grass collector, page 39.

Driving Forward or Backward

The throttle control regulates the engine speed as measured in rpm (revolutions per minute). Place the throttle control in the “FAST” position for best performance.

To go forward, release the parking brake; refer to Releasing the Parking Brake, page 13. Place your foot on the traction control pedal and slowly press on the pedal to move forward (Fig. 14). The farther you move the traction control pedal, the faster the machine will move forward. To slow down release the pressure on the traction control pedal.

To go backward, release the parking brake; refer to Releasing the Parking Brake, page 13. Place your foot on the reverse speed pedal and slowly press on the pedal to move backward (Fig. 14). The farther you move the reverse speed pedal, the faster the machine will move backward. To slow down release the pressure on the reverse speed pedal.

IMPORTANT: To avoid transmission damage, always release the parking brake before moving the traction control pedal or the reverse speed pedal.

IMPORTANT: To prevent damage to the mower, always put the mower in the highest cutting position when you drive the tractor off the lawn.

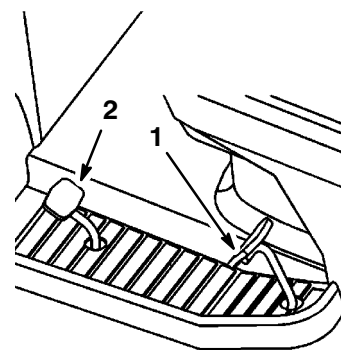

Figure 14

1. Traction control pedal 2. Reverse speed pedal

Stopping the Machine

To stop the machine, release the traction control pedal or reverse speed pedal, disengage the PTO, and turn the ignition key to “OFF” to stop the engine. Also set the parking brake if you leave the machine unattended; refer to Setting the Parking Brake, page 13. Remember to remove the key from the ignition switch.

CAUTION

POTENTIAL HAZARD

- Someone could move or attempt to operate the tractor while it is unattended.

WHAT CAN HAPPEN

- Children or bystanders may be injured if they use the tractor.

HOW TO AVOID THE HAZARD

- Always remove the ignition and “key choice” keys and set the parking brake when leaving the machine unattended, even if just for a few minutes.

Emptying the Grass Collector

When the collector warning light (Fig. 4) comes on and the buzzer sounds, the grass collector is full and must be emptied.

IMPORTANT: To prevent the discharge tunnel from getting clogged, the blade control (PTO) must be disengaged when the warning light and buzzer are activated.

1. Disengage the PTO and move the throttle to SLOW.
2. Pull out the telescoping dump lever and push it forward and down to empty the grass collector (Fig. 15).

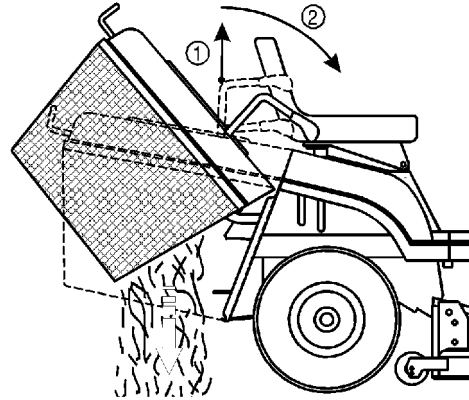

Figure 15

1. Pull up
2. Push forward and down

3. Slowly pull the dump lever upward to return the grass collector to the operating position.

Towing Attachments

The tractor is equipped for towing attachments with a maximum weight of 150 kg (331 lbs).

1. Remove the grass collector; refer to Removing the Grass Collector, page 39.
2. Install the attachment to the towing hitch located at the lower rear part of the tractor (Fig. 16).

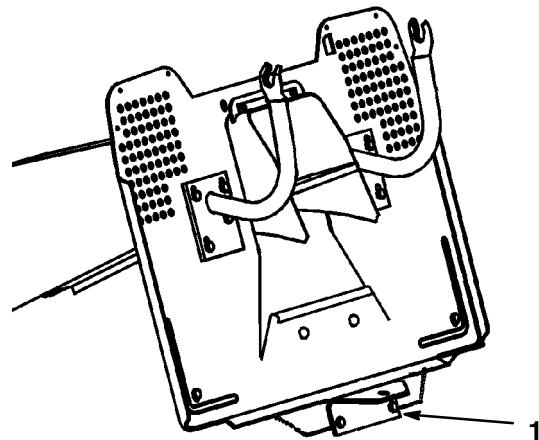

Figure 16

1. Towing hitch

Tips for Mowing Grass

Fast Throttle Setting

For best mowing and maximum air circulation, operate the engine at “FAST.” Air is required to thoroughly cut grass clippings, so do not set the height-of-cut too low or totally surround the mower by uncut grass. Always try to have one side of the mower free from uncut grass, which allows air to be drawn into the mower.

Cutting a Lawn for the First Time

Cut grass slightly longer than normal to ensure the cutting height of the mower does not scalp any uneven ground. However, the cutting height used in the past is generally the best one to use. When cutting grass longer than six inches tall, you may want to cut the lawn twice to assure an acceptable quality-of-cut.

Cut 1/3 of the Grass Blade

It is best to cut only about 1/3 of the grass blade. Cutting more than that is not recommended, unless grass is sparse or it is late fall when grass grows more slowly.

Mowing Direction

Alternate mowing direction to keep the grass standing straight. This also helps disperse clippings which enhances decomposition and fertilization.

Mow at Correct Intervals

Normally, mow every 4 days. But remember, grass grows at different rates at different times. So to maintain the same cutting height, which is a good practice, mow more often in early spring. As the grass growth rate slows in mid summer, mow less frequently. If you cannot mow for an extended period, first mow at a high cutting height; then mow again 2 days later at a lower height setting.

Avoid Cutting Too Low

If the cutting width of the mower is wider than the mower you previously used, raise the cutting height one notch to ensure uneven turf is not cut too short.

Long Grass

If the grass is ever allowed to grow slightly longer than normal, or if it contains a high degree of moisture, raise the cutting height higher than usual and cut the grass at this setting. Then cut the grass again using the lower, normal setting.

When Stopping

If the machine’s forward motion must be stopped while mowing, a clump of grass clippings may drop onto your lawn. To avoid this:

1. With the blade(s) “ENGAGED,” move onto a previously cut area.
2. To disperse the clippings evenly, raise the mower one or two height-of-cut settings while driving forward with the blade(s) “ENGAGED.”

Keep the Underside of the Mower Clean

Use the washout port to clean clippings and dirt from the underside of the mower after each use. If grass and dirt build up inside the mower, cutting quality will eventually become unsatisfactory.

Blade Maintenance

Maintain a sharp blade throughout the cutting season because a sharp blade cuts cleanly without tearing or shredding the grass blades. Tearing and shredding turns grass brown at the edges, which slows growth and increases the chance of disease. Every 30 days, check the cutter blade(s) for sharpness and file down any nicks.

Maintenance

Service Interval Chart

| Service Operation | Each Use | 5 Hours | 25 Hours | 50 Hours | 100 Hours | Storage Service | Notes |
|-----------------------------------|----------|---------|----------|----------|-----------|-----------------|---|
| Oil—initial change | | X | | | | | |
| Oil—periodic change | | | | X | | X | Every 25 hours under heavy load or high ambient temperature |
| Oil—check level | X | | | | | | |
| Oil Filter—replace | | | | | X | | |
| Safety System—check | X | X | X | | | | |
| Cutter Blade—check | | X | X | | | X | |
| Brake—check | | X | X | | X | X | |
| Chassis—grease | | | X | | | X | More often in dusty, dirty conditions |
| Foam Air Cleaner—service | | | X | | | X | |
| Paper Air Cleaner—replace | | | | | X | X | |
| Spark Plug—check | | | | | X | X | |
| Blade Drive Belt—adjust | | | | X | | | Initial check at 20 hours |
| Belts—check for wear/cracks | | | | | | X | |
| Gasoline—drain | | | | | | X | |
| Engine—clean outside | | | X | | | X | |
| Mower Housing—clean | X | X | | | | X | |
| Chipped Surfaces—paint | | | | | | X | |
| Battery—check electrolyte | X | X | X | | X | X | |
| Battery—charge, disconnect cables | | | | | | X | |
| Fuel Filter—replace | | | | | | X | |
| Tires—check pressure | X | | X | | | X | |

IMPORTANT: Refer to your engine operator's manual for additional maintenance procedures.

 **CAUTION****POTENTIAL HAZARD**

- If you leave the key in the ignition switch, someone could start the engine.

WHAT CAN HAPPEN

- Accidental starting of the engine could seriously injure you or other bystanders.

HOW TO AVOID THE HAZARD

- Remove the key from the ignition switch and pull the wire(s) off the spark plug(s) before you do any maintenance. Also push the wire(s) aside so it does not accidentally contact the spark plug(s).

Greasing and Lubrication

Service Interval/Specification

Grease the machine after every 25 operating hours or once a year, whichever occurs first. Grease more frequently when operating conditions are extremely dusty or sandy.

Grease Type: General-purpose grease.

How to Grease

1. Disengage the blade control (PTO), set the parking brake, stop the engine, and remove the ignition key.
2. Clean the grease fittings with a rag. Make sure to scrape any paint off the front of the fitting(s).
3. Connect a grease gun to the fitting. Pump grease into the fittings.
4. Wipe up any excess grease.

Where to Add Grease

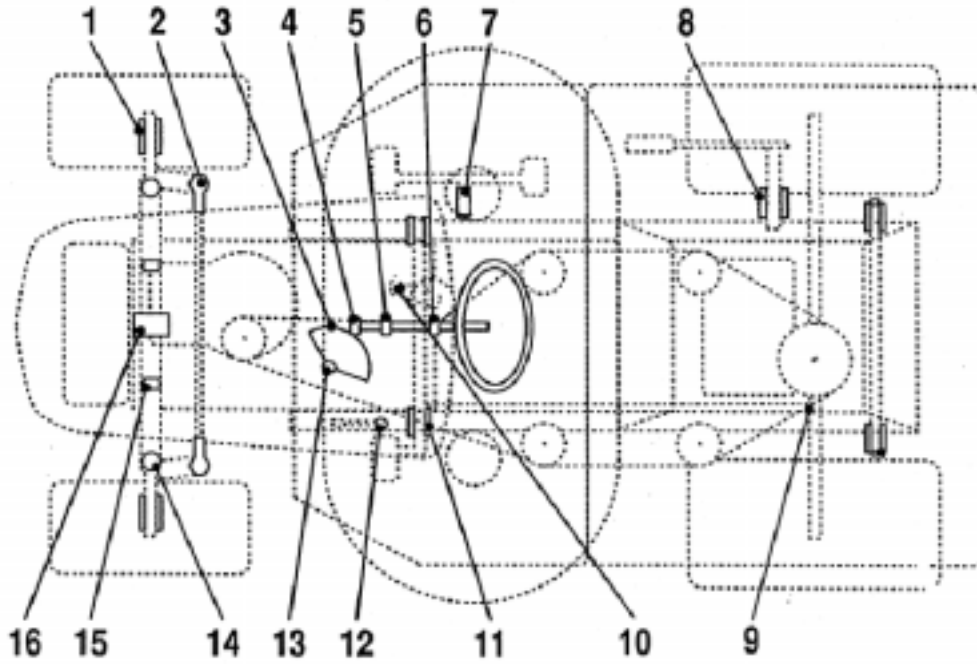

Figure 17

Lubrication List

| Item | Name | Quantity | Interval (hours) | Lubricant |
|------|---------------------------------------|----------|------------------|-----------|
| 1 | Front wheel—grease fitting | 2 | 25 | Grease |
| 2 | Steering ball joints | 4 | 50 | Oil |
| 3 | Steering sector gear | 1 | 50 | Grease |
| 4 | Steering pinion gear | 1 | 25 | Grease |
| 5 | Steering shaft bearing | 1 | 50 | Oil |
| 6 | Steering shaft bearing | 1 | 50 | Oil |
| 7 | Motion lever—grease fitting | 1 | 50 | Grease |
| 8 | Shaft hub for lifting the mower deck | 1 | 50 | Oil |
| 9 | Motion link ball joints | 4 | 50 | Oil |
| 10 | Brake pedal hub | 2 | 50 | Oil |
| 11 | Parking brake ring | 1 | 50 | Oil |
| 12 | Steering bearing | 1 | 25 | Grease |
| 13 | Left and Right Spindle—grease fitting | 2 | 25 | Grease |
| 14 | Mower deck hinged pin | 6 | When removed | Grease |
| 15 | Front axle pivot pin | 2 | When removed | Grease |
| 16 | Front axle pivot pin | 2 | 25 | Grease |

Tire Pressure

Service Interval/Specification

Maintain the air pressure in the front tires at 120 kPa and in the rear tires at 100 kPa. Check the pressure at the valve stem after every 25 operating hours or yearly, whichever occurs first (Fig. 18). Check the tires when they are cold to get the most accurate pressure reading.

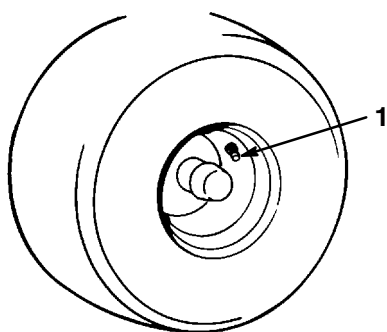

Figure 18

1. Valve stem

1872

Brake

The brake is on the right side of the rear axle, inside the rear tire (Fig. 19). If the tractor requires more than one meter to stop at high speed in the highest gear, then the brake must be adjusted.

Checking the Brake

1. Park the machine on a level surface, disengage the blade control (PTO), set the parking brake, stop the engine, and remove the ignition key.
2. Pull the drive control out to the “PUSH” position (Fig. 13).
3. If the rear wheels lock and skid when you push the tractor forward, no adjustment is required. An adjustment is required if the wheels turn and do not lock; refer to Adjusting the Brake, page 25.

Adjusting the Brake

1. Check the brake before you adjust it; refer to Checking the Brake, page 25.
2. Ensure the drive control is in the “OPERATE” position (Fig. 13) and the parking brake is on.
3. To adjust the brake, turn the brake adjusting nut clockwise until you can not push the tractor (Fig. 19).
4. Release the parking brake and ensure the rear wheels rotate freely when you push the tractor. If they do not, turn the brake adjusting nut counterclockwise just until you can push the tractor.
5. Check the brake operation again; refer to Check the Brake, page 25.

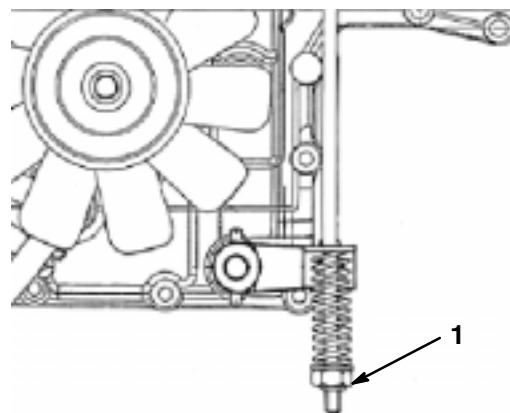

Figure 19

1. Brake adjusting nut

Fuse

Service Interval/Specification

The electrical system is protected by fuses. They are located beneath the hood, near the fuel tank (Fig. 20). No maintenance is required, however, if a fuse blows check the circuit wiring for a short.

Fuses: Main, battery—15 amp
 Headlights—10 amp
 Interlock, electric clutch—10 amp
 Full bag buzzer—5 amp

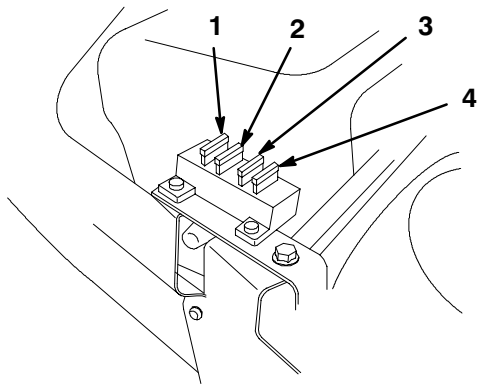
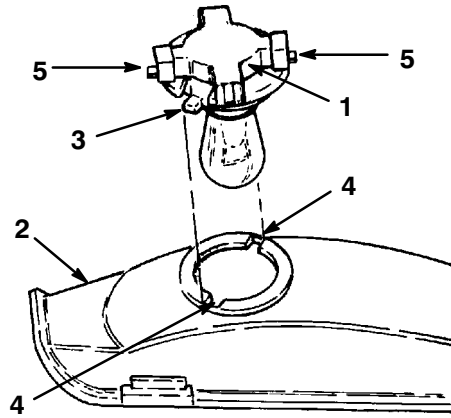

Figure 20

- | | |
|------------------|-------------------------------|
| 1. Main, battery | 3. Interlock, electric clutch |
| 2. Headlights | 4. Full bag buzzer |

4. Push and rotate the bulb counterclockwise until it stops (approx. 1/4 turn) and remove bulb from the bulb holder (Fig. 22).



1874

Figure 21

- | | |
|----------------|--------------|
| 1. Bulb holder | 4. Slots |
| 2. Reflector | 5. Terminals |
| 3. Tabs | |

Installing the Bulb

1. The bulb has metal pins on the side of its base. Align the pins with the slots in the bulb holder and insert the base into the holder (Fig. 22). Push and rotate the bulb clockwise until it stops.

Headlights

Specification: Bulb # 1156, automotive type.

Removing the Bulb

1. Disengage the blade control (PTO), set the parking brake, stop the engine, and remove the ignition key.
2. Open the hood. Pull the wire connectors off both bulb holder terminals.
3. Rotate the bulb holder 1/4 turn counterclockwise and remove it from the reflector (Fig. 21).

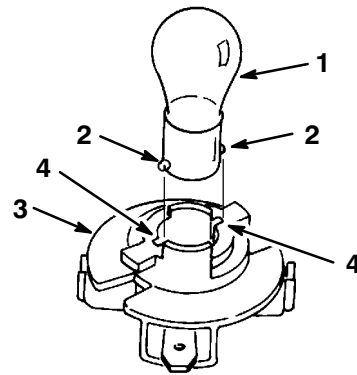

1875

Figure 22

- | | |
|---------------|----------------|
| 1. Bulb | 3. Bulb holder |
| 2. Metal pins | 4. Slots |

2. The bulb holder has two tabs (Fig. 21). Align the tabs with the slots in the reflector, insert the bulb holder into the reflector and rotate it 1/4 turn clockwise until it stops.
3. Push the wire connectors onto the terminals on the bulb holder.

Battery

Service Interval/Specification

Check the electrolyte level in the battery before each use. Always keep the battery clean and fully charged. Use a paper towel to clean the battery and battery box. If the battery terminals are corroded, clean them with a solution of four parts water and one part baking soda. Apply a light coating of grease to the battery terminals to prevent corrosion.

Voltage: 12 v, 190 Cold Cranking Amps

Removing the Battery

1. Disengage the blade control (PTO), set the parking brake, stop the engine, and remove the ignition key.
2. Tip the seat forward to see the battery.
3. Lift the rubber cover up off the negative (black) cable. Disconnect the negative (black) ground cable from the battery post (Fig. 23).

WARNING

POTENTIAL HAZARD

- Either the battery terminals or metal tools could short against metal tractor components.
- Incorrect battery cable routing could damage the cables.

WHAT CAN HAPPEN

- Sparks can cause the battery gasses to explode.
- Damaged cables could short against metal tractor components and cause sparks.

HOW TO AVOID THE HAZARD

- When removing or installing the battery, do not allow the battery terminals to touch any metal parts of the tractor.
- Always DISCONNECT the negative (black) battery cable before disconnecting the positive (red) cable.
- Always RECONNECT the positive (red) battery cable before reconnecting the negative (black) cable.
- Do not allow metal tools to short between the battery terminals and metal parts of the tractor.
- Always keep the battery hold-down in place to protect and secure the battery.
- Always route the battery cables as illustrated.

4. Lift the rubber cover up off the positive (red) cable. Disconnect the positive (red) cable from the battery post (Fig. 23).
5. Remove the battery hold down rod (Fig. 23).
6. Remove the battery from the chassis.

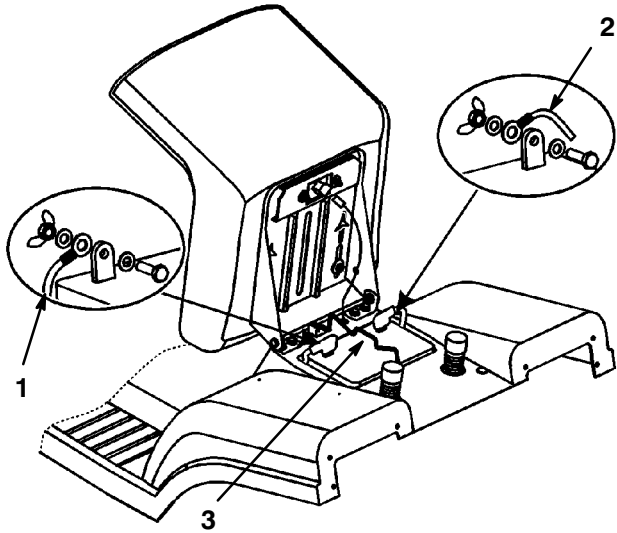

Figure 23

- | | |
|---------------------------|------------------|
| 1. Negative cable (black) | 3. Hold-down rod |
| 2. Positive cable (red) | |

Installing the Battery

1. Place the battery into the chassis with the battery posts toward the front of the tractor (Fig. 23).
2. Secure the battery in the chassis with the hold down rod (Fig. 23).
3. Using the bolt and wing nut, connect the positive (red) cable to the positive (+) battery post (Fig. 23). Slide the rubber cover over the battery post.
4. Using the bolt and wing nut, connect the negative (black) cable to the negative (-) battery post (Fig. 23). Slide the rubber cover over the battery post.

Checking Electrolyte Level

1. Tip the seat forward to see the battery.
2. Remove the filler caps. If the electrolyte is not up to the lower part of the tube (Fig. 24), add the required amount of distilled water; refer to Adding Water to the Battery, page 28.

DANGER

POTENTIAL HAZARD

- Battery electrolyte contains sulfuric acid which is a deadly poison and it causes severe burns.

WHAT CAN HAPPEN

- If you carelessly drink electrolyte you could die or if it gets onto your skin you will be burned.

HOW TO AVOID THE HAZARD

- Do not drink electrolyte and avoid contact with skin, eyes or clothing. Wear safety glasses to shield your eyes and rubber gloves to protect your hands.
- Fill the battery where clean water is always available for flushing the skin.
- Follow all instructions and comply with all safety messages on the electrolyte container.

Adding Water to the Battery

The best time to add distilled water to the battery is just before you operate the machine. This lets the water mix thoroughly with the electrolyte solution.

1. Clean the top of the battery with a paper towel.
2. Remove the filler caps (Fig. 24).

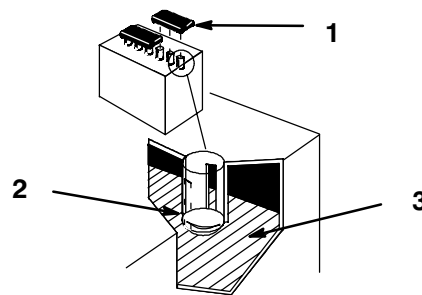

Figure 24

- | | |
|-----------------------|-----------|
| 1. Filler caps | 3. Plates |
| 2. Lower part of tube | |

1262

- Slowly pour distilled water into each battery cell until the level is up to the lower part of the tube (Fig. 24).

IMPORTANT: Do not overfill the battery. Electrolyte (sulfuric acid) can cause severe corrosion and damage to the chassis.

- Replace the filler caps.

Charging the Battery

IMPORTANT: Always keep the battery fully charged (1.260 specific gravity). This is especially important to prevent battery damage when the temperature is below 32°F (0°C).

- Remove the battery from the chassis; refer to Removing the Battery, page 27.
- Check the electrolyte level; refer to Checking Electrolyte Level, page 28.
- Remove the filler caps from the battery and connect a 3 to 4 amp battery charger to the battery posts. Charge the battery at a rate of 4 amperes or less for 4 hours (12 volts). Do not overcharge the battery. Install the filler caps after the battery is fully charged.

WARNING

POTENTIAL HAZARD

- Charging the battery produces gasses.

WHAT CAN HAPPEN

- Battery gasses can explode.

HOW TO AVOID THE HAZARD

- Keep cigarettes, sparks and flames away from battery.

- Install the battery in the chassis; refer to Installing the Battery, page 28.

Spark Plug

Service Interval/Specification

Install a new spark plug(s) after every 100 operating hours. Make sure the air gap between the center and side electrodes is correct before installing the spark plug(s). Use a spark plug wrench for removing and installing the spark plug(s) and a gapping tool/feeler gauge to check and adjust the air gap.

Type: Champion RC12YC (or equivalent)

Air Gap: .76mm (0.030")

Removing the Spark Plug(s)

- Disengage the blade control (PTO), set the parking brake, stop the engine, and remove the ignition key.
- Open the hood.
- Pull the wire(s) off the spark plug(s) (Fig. 25). Clean around the spark plug(s) to prevent dirt from falling into the engine and potentially causing damage.
- Remove the spark plug(s) and metal washer.

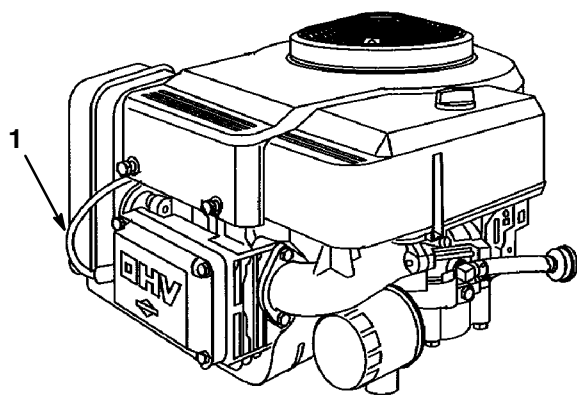

Figure 25

- Spark plug wire

Checking the Spark Plug(s)

1. Look at the center of the spark plug(s) (Fig. 26). If you see light brown or gray on the insulator, the engine is operating properly. A black coating on the insulator usually means the air cleaner is dirty.

IMPORTANT: Never clean the spark plug(s). Always replace the spark plug(s) when it has a black coating, worn electrodes, an oily film, or cracks.

2. Check the gap between the center and side electrodes (Fig. 26). Bend the side electrode (Fig. 26) if the gap is not correct.

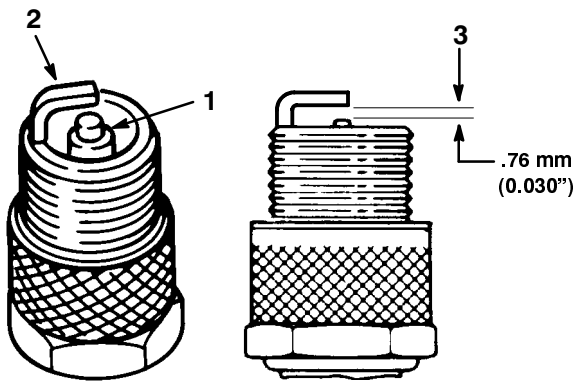

1870

Figure 26

- | | |
|-------------------------------|---------------------------|
| 1. Center electrode insulator | 3. Air gap (not to scale) |
| 2. Side electrode | |

Installing the Spark Plug(s)

1. Install the spark plug(s) and metal washer. Make sure the air gap is set correctly.
2. Tighten the spark plug(s) to 15 ft-lb (20.4 Nm).
3. Push the wire(s) onto the spark plug(s) (Fig. 25).
4. Close the hood.

Fuel Tank

The fuel tank must be drained when the machine will not be used for more than 30 days.

DANGER

POTENTIAL HAZARD

- In certain conditions, gasoline is extremely flammable and highly explosive.

WHAT CAN HAPPEN

- A fire or explosion from gasoline can burn you, others, and cause property damage.

HOW TO AVOID THE HAZARD

- Drain gasoline from the fuel tank when the engine is cold. Do this outdoors in an open area. Wipe up any gasoline that spills.
- Never drain gasoline near an open flame or where gasoline fumes may be ignited by a spark.
- Never smoke a cigarette, cigar or pipe when handling gasoline.

1. Park the machine so that the left front side is slightly lower than the right side to assure fuel drains completely. Disengage the PTO, set the parking brake, stop the engine, and remove the ignition key.
2. Open the hood.
3. Squeeze the ends of the hose clamp together and slide it up the fuel line toward the fuel tank (Fig. 27).
4. Pull the fuel line off the filter (Fig. 27) and allow gasoline to drain into a gas can or drain pan.

Note: Now is the best time to install a new fuel filter because the fuel tank is empty.

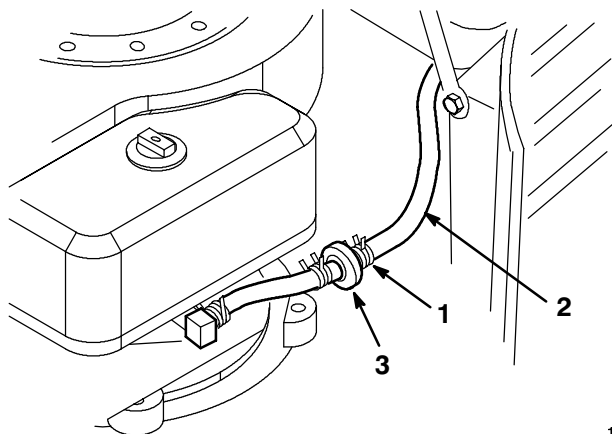

Figure 27

1. Hose clamp
2. Fuel line
3. Filter

5. Install the fuel line onto the filter. Slide the hose clamp close to the filter to secure the fuel line and filter.

Fuel Filter

Service Interval/Specification

Replace the fuel filter after every 100 operating hours or yearly, whichever occurs first.

Replacing the Fuel Filter

The best time to replace the fuel filter (Fig. 27) is when the fuel tank is empty. Never install a dirty filter if it is removed from the fuel line.

1. Disengage the blade control (PTO), set the parking brake, stop the engine, and remove the ignition key.
2. Turn the fuel shut-off valve off (Fig. 28).

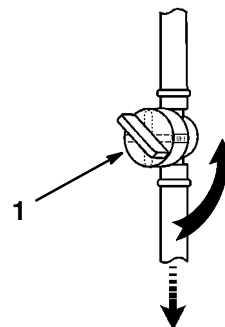

Figure 28

- 1.
- 2.

3. Open the hood.
4. Squeeze the ends of the hose clamps together and slide them away from the filter (Fig. 27).
5. Remove the filter from the fuel lines.
6. Install a new filter and move the hose clamps close to the filter.
7. Close the hood.

Air Cleaner

Service Interval/Specification

Foam Element: Clean and re-oil after every 25 operating hours, or yearly, whichever occurs first.

Paper Element: Replace after every 100 operating hours or yearly, whichever occurs first.

Note: Service the air cleaner more frequently (every few hours) if operating conditions are extremely dusty or sandy.

Removing the Foam and Paper Elements

1. Disengage the blade control (PTO), set the parking brake, stop the engine, and remove the ignition key.
2. Open the hood.
3. Clean around the air cleaner to prevent dirt from getting into the engine and causing damage. Unscrew the knob and remove the air cleaner cover (Fig. 29).

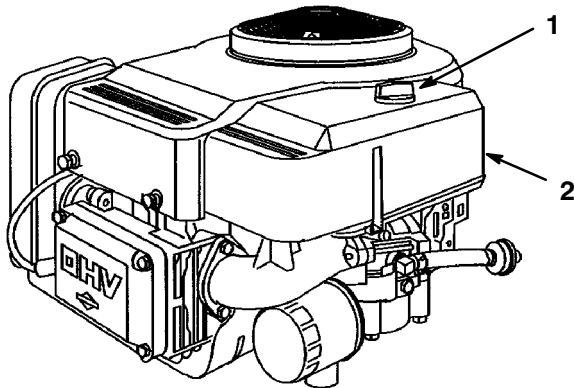

Figure 29

1. Knob
2. Air cleaner cover

4. Carefully slide the foam element off the paper element (Fig. 30).

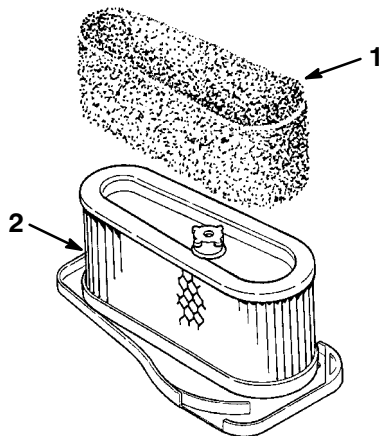

Figure 30

1. Foam element
2. Paper element

5. Unscrew the rubber nut and remove the paper element (Fig. 31).

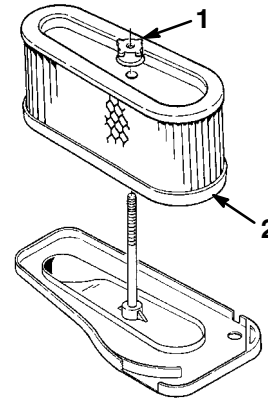

Figure 31

1. Rubber nut
2. Paper element

Cleaning the Foam and Paper Elements

1. Foam Element
 - A. Wash the foam element in liquid soap and warm water. When the element is clean, rinse it thoroughly.
 - B. Dry the element by squeezing it in a clean cloth.
 - C. Saturate the element in engine oil (Fig. 32). Squeeze the element in a clean, absorbant cloth to remove excess oil.

IMPORTANT: Replace the foam element if it is torn or worn.



Figure 32

1. Foam element
2. Oil

2. Paper Element

- A. Lightly tap the element on a flat surface to remove dust and dirt (Fig. 33).
- B. Inspect the element for tears, an oily film, and damage to the rubber seal.

IMPORTANT: Never clean the paper element with pressurized air or liquids, such as solvent, gas, or kerosene. Replace the paper element if it is damaged or cannot be cleaned thoroughly.

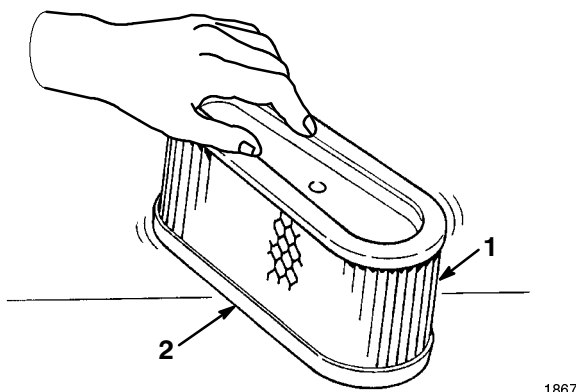

Figure 33

1. Paper element
2. Rubber seal

Installing the Foam and Paper Elements

IMPORTANT: To prevent engine damage, always operate the engine with the complete foam and paper air cleaner assembly installed.

1. Carefully slide the foam element onto the paper air cleaner element (Fig. 30).
2. Slide the air cleaner assembly onto the long rod. Screw the rubber nut finger-tight against the air cleaner (Fig. 31).

Note: Make sure the rubber seal is flat against the air cleaner base.

3. Install the air cleaner cover and knob (Fig. 29). Tighten the knob snugly.
4. Close the hood.

Engine Oil

Service Interval/Specification

Change oil:

- After the first 5 operating hours.
- After every 50 operating hours.

Note: Change oil every 25 hours when operating engine under heavy load or in high temperatures.

Oil Type: Detergent oil (API service SF, SG, or SH)

Crankcase Capacity: 1.9 liters (64 oz.)

Viscosity: See table below

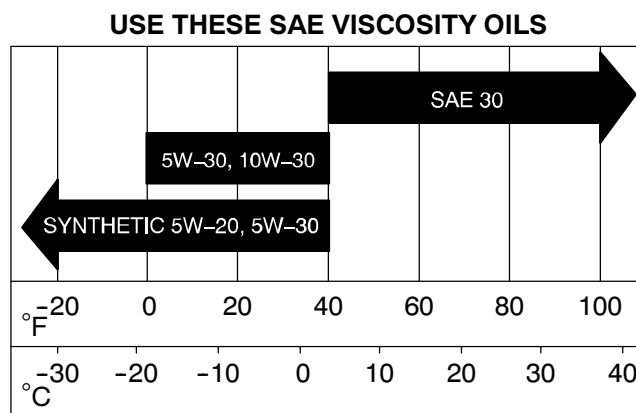

Checking Oil Level

1. Park the machine on a level surface, disengage the blade control (PTO), set the parking brake, stop the engine, and remove the ignition key.
2. Open the hood.
3. Clean around the oil dipstick (Fig. 34) so dirt cannot fall into the filler hole and damage the engine.

4. Unscrew the oil dipstick and wipe the metal end clean (Fig. 34).
5. Screw the oil dipstick fully onto the filler tube (Fig. 34). Unscrew the dipstick again and look at the metal end. If oil level is low, slowly pour only enough oil into the filler tube to raise the level to the “FULL” mark. Tighten the dipstick.
6. Start and run the engine at idle for 30 seconds.
7. Shut the engine off and wait for 30 seconds. Check the oil level again and add oil if necessary.

IMPORTANT: Do not overfill the crankcase with oil because the engine may become damaged.

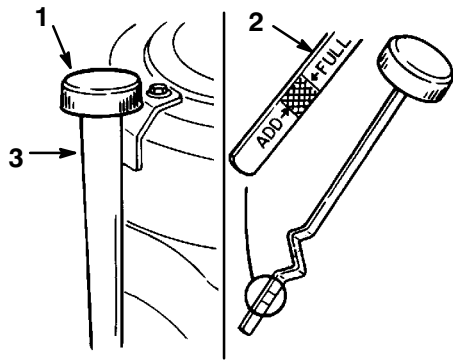

Figure 34

1. Oil dipstick
2. Metal end
3. Filler tube

1868

4. Place a pan below the oil dipstick/fill tube and remove the drain plug (Fig. 35).
5. When oil has drained completely, install the drain plug.

Note: Dispose of the used oil at a certified recycling center.
6. Change oil filter if necessary; refer to Change Oil Filter, page 34.
7. Slowly pour approximately 80% of the specified amount of oil into the filler tube (Fig. 34). Now check the oil level; refer to Checking Oil Level, page 33. Slowly add additional oil to bring to FULL mark on dipstick.

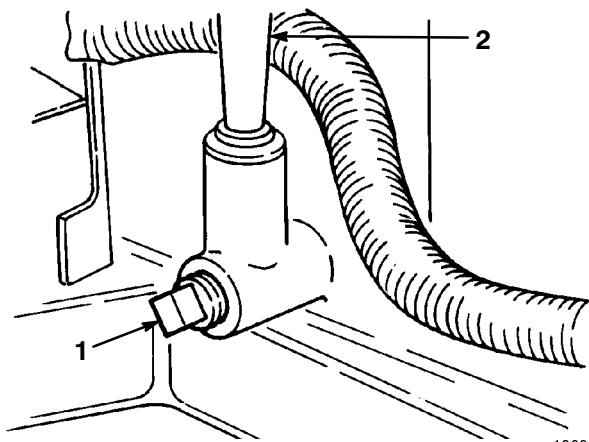

Figure 35

1. Oil drain plug
2. Oil dipstick/fill tube

1869

Changing/Draining Oil

1. Start the engine and let it run five minutes. This warms the oil so it drains better.
2. Park the machine so that the drain side is slightly lower than the opposite side to assure the oil drains completely. Then disengage the blade control (PTO), set the parking brake, stop the engine, and remove the ignition key.
3. Open the hood.

Change Oil Filter—Service Interval/Specification

Replace the oil filter every 100 hours or yearly, whichever occurs first.

1. Drain the oil from the engine; refer to Changing/Draining Oil, page 34.
2. Remove the old filter and wipe the filter adapter (Fig. 36) gasket surface.
3. Apply a thin coat of new oil to the rubber gasket on the replacement filter (Fig. 36).

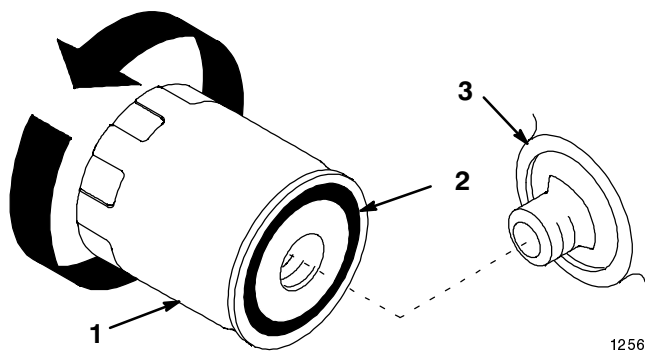

Figure 36

1. Oil filter
2. Gasket
3. Adapter

- Install the replacement oil filter to the filter adapter. Turn the oil filter clockwise until the rubber gasket contacts the filter adapter, then tighten the filter an additional 1/2 to 3/4 turn (Fig. 36).
- Fill the crankcase with the proper type of new oil; refer to Checking Oil Level, page 33.

Cutting Blade

To assure a superior quality of cut, keep the blades sharp. For convenient sharpening and replacement, you may want to have extra blades.

WARNING

POTENTIAL HAZARD

- A blade that is worn or damaged could break apart and pieces could be thrown at bystanders or at you as you use the mower.

WHAT CAN HAPPEN

- Pieces of blade that may be thrown could seriously injure or kill you or bystanders.

HOW TO AVOID THE HAZARD

- Periodically inspect the blade for wear and damage. Immediately install a new blade if it is worn or damaged.

Inspecting the Blades

- Remove the mower; refer to Removing the Mower, page 37.
- Inspect the cutting edges (Fig. 37). If the edges are not sharp or have nicks, remove the blades and sharpen them; refer to Sharpening the Blade(s), page 36.
- Inspect the blades, especially the bent edges (Fig. 37). If you notice any wear or damage in this area, immediately install a new blade.
- If the shear pins are broken, replace them immediately (Fig. 37).

IMPORTANT: If the shear pins are broken, the mower belt may be damaged. Inspect the belt; refer to Adjusting the Blade Drive Belt, page 38.

Removing the Blade

- Remove the mower; refer to Removing the Mower, page 37.
- Carefully tip the mower over.
- Remove the bolt, washer and blade (Fig. 37). A block of wood may be wedged between the blade and the mower to lock the blade when you are removing the bolt.

Note: The right blade has a left hand threaded bolt.

- Inspect all parts. If a defect or damage is noticed, install new parts.

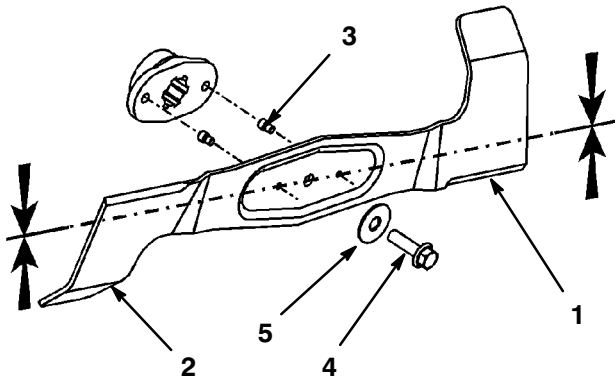

Figure 37

- | | |
|-----------------|-----------|
| 1. Cutting edge | 4. Bolt |
| 2. Bent edge | 5. Washer |
| 3. Shear pins | |

Sharpening the Blade(s)

1. Use a file to sharpen the cutting edge at both ends of the blade (Fig. 38). Maintain the original angle. The blade retains its balance if the same amount of material is removed from both cutting edges.

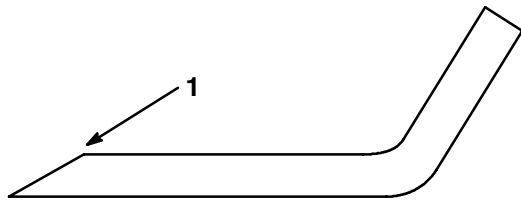

Figure 38

1. Sharpen at original angle

2. Check the balance of the blade by putting it on a blade balancer (Fig. 39). If the blade stays in a horizontal position, the blade is balanced and can be used. If the blade is not balanced, file some metal off the back side of the blade. Repeat this procedure until the blade is balanced.

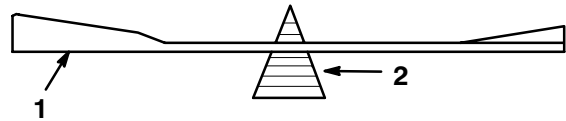

Figure 39

1. Blade
2. Balancer

Installing the Blade(s)

1. Install the blade, washer, and blade bolt (Fig. 37).

IMPORTANT: The bent edges of the blade must be pointing toward the top of the mower to assure proper cutting.

2. Position the blades 90 degrees to each other (Fig. 40).
3. Tighten the blade bolt to 50 Nm.

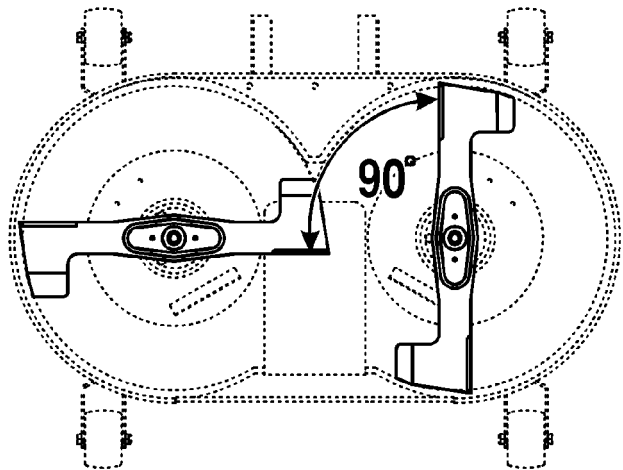

Figure 40

Removing the Mower

1. Park the machine on a level surface, disengage the PTO, set the parking brake, stop the engine, and remove the ignition key. Pull the wire off the spark plug(s).
2. Move the height-of-cut lever to the lowest position.
3. Pull the idler arm assembly in and remove the V-belt from the pulley (Fig. 41).
4. Disconnect the spring from the engagement lever (Fig. 41).
5. Release the mower from the tunnel by lifting the tunnel off the two welded pins and pulling the tunnel rearward approximately 10 cm. Secure the tunnel to prevent it from falling back down.

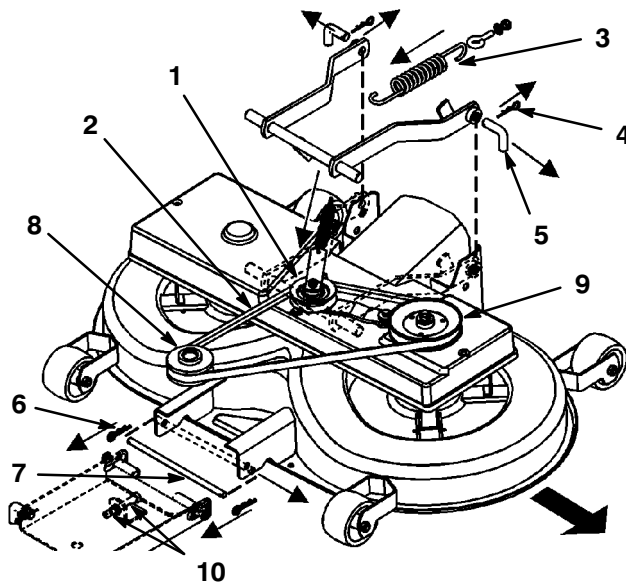

Figure 41

- | | |
|--|-------------------------------|
| 1. Idler pulley and idler arm assembly | 6. Front hairpin clips |
| 2. V-belt | 7. Front pin |
| 3. Engagement spring | 8. Engine pulley |
| 4. Rear hairpin clips | 9. V-belt pulley |
| 5. Rear pins | 10. Front suspension M12 nuts |

7. Remove the hairpin clip from the front pin and remove the pin (Fig. 41).
8. Remove the V-belt from the engine pulley (Fig. 41).
9. Slide the mower out from beneath the tractor.

Installing the Mower

Reverse the procedure for Removing the Mower, page 37.

6. Remove the hair pin clips from the two rear pins and remove the pins (Fig. 41). A pliers may be needed to pull the second pin out.

Adjusting the Blade Drive Belt

Adjust the blade drive belt after the first 20 operating hours and every 50 operating hours thereafter.

1. Remove the mower; refer to Removing the Mower, page 37.

Note: It is not possible to adjust the blade drive belt correctly without removing the mower.

2. Remove the V-belt pulley and idler arm assembly (Fig. 41).
3. Remove the belt cover.
4. Loosen the two hex nuts on the idler pulley (Fig. 42).
5. Adjust the M10 nut until the belt flexes 5 mm with 3 kp of force (Fig. 42).

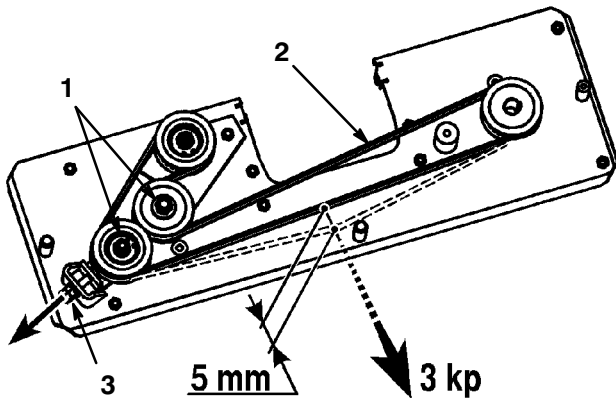

Figure 42
Top View

- | | |
|---------------|------------|
| 1. Hex nuts | 3. M10 nut |
| 2. Mower belt | |

6. Tighten the two hex nuts on the idler pulley.
7. Reinstall the mower; refer to Installing the Mower, page 37.

Adjusting the Height Adjustment Cable Rod Assembly

Check the front-to-rear blade slope every 100 hours, yearly, or any time you install the mower. Before you check the slope, set the air pressure in the front and rear tires to the recommended inflation; refer to Tire Pressure, page 25. If the front of the mower is not within a range of 3.5 mm–10.5 mm (1/8"–3/8") lower than the rear of the mower, adjust the blade slope using the following instructions:

1. Park the machine on a level surface, disengage the blade control (PTO), set the parking brake, stop the engine, and remove the ignition key. Pull the wire off the spark plug(s).
2. Move the lower pin of the front adjustment suspension into the bottom position of the slotted holes by adjusting the two M12 nuts on the front suspension (Fig. 41).
3. Move the height-of-cut lever to position 1. The front mower gauge wheels must rest on the ground.
4. Adjust the M8 locknut at the end of the height adjustment rod assembly until the rod is slightly taut (Fig. 43).

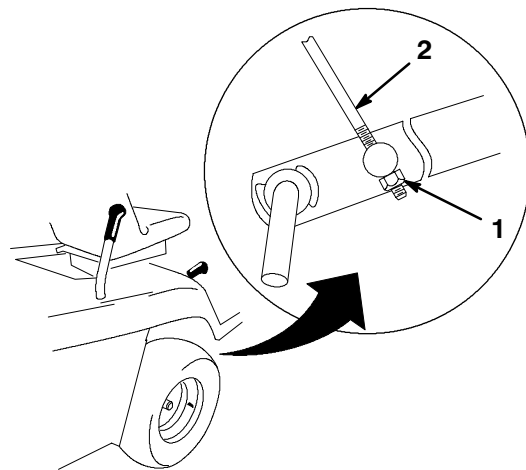

Figure 43

- | | |
|---------------|--------------------------|
| 1. M8 locknut | 2. Height adjustment rod |
|---------------|--------------------------|

m-4935

Grass Collector

Removing the Grass Collector

1. Using two hands, tip the grass collector forward (Fig. 44).
2. Carefully slide the assembly rearward off the support brackets.

Installing the Grass Collector

1. Lift the grass collector assembly with two hands.
2. Tip the collector forward approximately 40 degrees and slide it onto the two support brackets at the rear of the tractor (Fig. 44). Ensure the arrow on the top of the grass collector aligns with the arrow on the tractor.

Note: The cutting unit will not function when the grass collector is not in place.

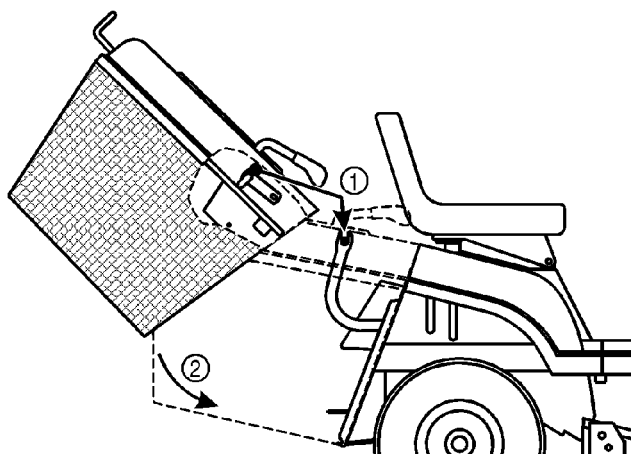

Figure 44

Cleaning the Grass Collector and Tunnel

If the holes on the grass collector bag become clogged with dirt and grass or if the full-bag sensor is dirty, the collector must be cleaned.

1. Disengage the blade control (PTO), set the parking brake, and turn the ignition key to “OFF” to stop the engine.
2. Remove the grass collector; refer to Removing the Grass Collector, page 39.
3. Clean the collector bag with pressurized water.
4. Wipe the area around the full-bag sensor.
5. Clean the inside of the tunnel all the way to the cutting unit.
6. Install the grass collector; refer to Installing the Grass Collector, page 39.

Note: Allow the bag to dry thoroughly before reinstalling.

Cleaning and Storage

1. Disengage the power take off (PTO), set the parking brake, stop the engine, and remove the key.
2. Remove the grass collector and clean it; refer to Grass Collector, page 39.
3. Remove grass clippings, dirt, and grime from the external parts of the entire machine, especially the engine. Clean dirt and chaff from the outside of the engine’s cylinder head fins and blower housing.

IMPORTANT: You can wash the machine with mild detergent and water. Do not use pressurized liquids to wash the machine. Pressurized liquids may damage the electrical system or wash away necessary grease at friction points. Avoid excessive use of water, especially near the control panel, lights, engine, and the battery.

4. Check the brake; refer to Brake, page 25.
5. Service the air cleaner; refer to Air Cleaner, page 31.

6. Grease the chassis; refer to Greasing and Lubrication, page 23.
7. Change the crankcase oil and filter; refer to Engine Oil, page 33.
8. Check the tire pressure; refer to Tire Pressure, page 25.
9. Prepare the machine for storage when non-use occurs over 30 days. Prepare machine for storage as follows.

A. Add a petroleum based stabilizer/conditioner to fuel in the tank. Follow mixing instructions from stabilizer manufacturer. (1 oz. per gallon). **Do not use an alcohol based stabilizer (ethanol or methanol).**

Note: A fuel stabilizer/conditioner is most effective when mixed with fresh gasoline and used at all times.

- B. Run engine to distribute conditioned fuel through the fuel system (5 minutes).
- C. Stop engine, allow to cool and drain the fuel tank; refer to Fuel Tank, page 30.
- D. Restart engine and run it until it stops.
- E. Choke or prime the engine.
- F. Start and run engine until it will not start. Operate primer, if equipped on machine, several times to ensure no fuel remains in primer system.
- G. Dispose of fuel properly. Recycle as per local codes.
- H. Close the fuel shut-off valve.

IMPORTANT: Do not store stabilizer/conditioned gasoline over 90 days.

10. Remove the spark plug(s) and check its condition; refer to Spark Plug, page 29. With the spark plug(s) removed from the engine, pour two tablespoons of engine oil into the spark plug hole. Now use the electric starter to crank the

engine and distribute the oil inside the cylinder. Install the spark plug(s); refer to Spark Plug, page 29. Do not install the wire on the spark plug(s).

11. Remove the battery from the chassis, check the electrolyte level, and charge it fully; refer to Battery, page 27. Do not connect the battery cables to the battery posts during storage.

IMPORTANT: The battery must be fully charged to prevent it from freezing and being damaged at temperatures below 32°F (0°C). A fully charged battery maintains its charge for about 50 days at temperatures lower than 40°F (4°C). If the temperatures will be above 40°F (4°C), check the water level in the battery and charge it every 30 days.

12. Check and tighten all bolts, nuts, and screws. Repair or replace any part that is damaged or defective.
13. Paint all scratched or bare metal surfaces. Paint is available from your Authorized Service Dealer.
14. Store the machine in a clean, dry garage or storage area. Remove the key from the ignition switch and keep it in a memorable place. Cover the machine to protect it and keep it clean.

Troubleshooting

| PROBLEM | POSSIBLE CAUSES | CORRECTIVE ACTION |
|---|---|--|
| Starter does not crank. | <ol style="list-style-type: none"> 1. Blade control (PTO) is ENGAGED. 2. Parking brake is not on. 3. Battery is dead. 4. Electrical connections are corroded or loose. 5. Fuse is blown. 6. Relay or switch is defective. | <ol style="list-style-type: none"> 1. Move blade control (PTO) to DISENGAGED. 2. Set parking brake. 3. Charge the battery. 4. Check electrical connections for good contact. 5. Replace fuse. 6. Contact Authorized Service Dealer. |
| Engine will not start, starts hard, or fails to keep running. | <ol style="list-style-type: none"> 1. Operator is not seated. 2. Fuel tank is empty. 3. Air cleaner is dirty. 4. Spark plug wire is loose or disconnected. 5. Spark plug is pitted, fouled, or gap is incorrect. 6. Choke is not closing. 7. Dirt in fuel filter. 8. Idle speed is too low or mixture is incorrect. 9. Dirt, water, or stale fuel is in fuel system. 10. Fuel shut-off valve is closed. | <ol style="list-style-type: none"> 1. Sit on the seat. 2. Fill fuel tank with gasoline. 3. Clean or replace air cleaner element. 4. Install wire on spark plug. 5. Install new, correctly gapped spark plug. 6. Adjust throttle cable. 7. Replace fuel filter. 8. Adjust carburetor idle speed and idle mixture. 9. Contact Authorized Service Dealer. 10. Open fuel shut-off valve. |
| Engine overheats. | <ol style="list-style-type: none"> 1. Engine load is excessive. 2. Oil level in crankcase is low. 3. Cooling fins and air passages under engine blower housing are plugged. | <ol style="list-style-type: none"> 1. Reduce ground speed. 2. Add oil to crankcase. 3. Remove obstruction from cooling fins and air passages. |
| Machine does not drive. | <ol style="list-style-type: none"> 1. Drive control is in "PUSH" position. 2. Traction belt is worn, loose or broken. 3. Traction belt is off pulley. | <ol style="list-style-type: none"> 1. Move drive control to "OPERATE" position. 2. Contact Authorized Service Dealer. 3. Contact Authorized Service Dealer. |

| PROBLEM | POSSIBLE CAUSES | CORRECTIVE ACTION |
|---------------------------|--|--|
| Engine loses power. | <ol style="list-style-type: none"> 1. Engine load is excessive. 2. Air cleaner is dirty. 3. Oil level in crankcase is low. 4. Cooling fins and air passages under engine blower housing are plugged. 5. Spark plug is pitted, fouled, or gap is incorrect. 6. Vent hole in fuel cap is plugged. 7. Dirt in fuel filter. 8. Dirt, water, or stale fuel is in fuel system. | <ol style="list-style-type: none"> 1. Reduce ground speed. 2. Clean air cleaner element. 3. Add oil to crankcase. 4. Remove obstruction from cooling fins and air passages. 5. Install new, correctly gapped spark plug. 6. Clean or replace the fuel cap. 7. Replace fuel filter. 8. Contact Authorized Service Dealer. |
| Abnormal vibration. | <ol style="list-style-type: none"> 1. Cutting blade(s) is bent or unbalanced. 2. Blade mounting screws are loose. 3. Engine mounting bolts are loose. 4. Loose engine pulley, idler pulley, or blade pulley. 5. Engine pulley is damaged. 6. Blade drive belt is damaged. | <ol style="list-style-type: none"> 1. Install new cutting blade(s). 2. Tighten blade mounting screws. 3. Tighten engine mounting bolts. 4. Tighten the appropriate pulley. 5. Contact Authorized Service Dealer. 6. Install new blade drive belt. |
| Blade(s) does not rotate. | <ol style="list-style-type: none"> 1. Blade drive belt is worn, loose or broken. 2. Blade drive belt is off pulley. 3. Grass collector is not in place. | <ol style="list-style-type: none"> 1. Install new blade drive belt. 2. Install blade drive belt and adjust for correct tension. 3. Install grass collector. |
| Uneven cutting height. | <ol style="list-style-type: none"> 1. Tire pressure is incorrect. 2. Mower is not level. 3. Underside of mower is dirty. 4. Blade mounting screws are loose. 5. Blade drive belt tension is incorrect. | <ol style="list-style-type: none"> 1. Set tire pressure. 2. Adjust the height adjustment cable rod assembly. 3. Clean the underside of the mower. 4. Tighten blade mounting screws. 5. Adjust blade drive belt. |