



Flush-face Hydraulic Coupler Kit
for Dingo® Traction Units and Attachments

Part No.: 100-4744, 100-4745,
100-4746, 100-4750, and 100-4751

**Installation
Instructions**

DESCRIPTION	QTY.	USE
Adapter	2	Install on traction unit or attachment
Flush-face coupler, female	1	
Flush-face coupler, male	1	
Coupler cover, male (traction unit kits only)	1	
Coupler cover, male (traction unit kits only)	1	

1. If you are installing a kit onto a traction unit, stop the engine, remove the key, and move the auxiliary hydraulics lever forward, rearward, and back to neutral.
2. Allow the traction unit or attachment to cool completely.

CAUTION

POTENTIAL HAZARD

- Quick couplers, hydraulic lines/valves, and hydraulic fluid may be hot.

WHAT CAN HAPPEN

- Contact with hot hydraulic components or fluid may cause burns.

HOW TO AVOID THE HAZARD

- Allow the traction unit or attachment to cool before touching hydraulic components.

WARNING

POTENTIAL HAZARD

- Hydraulic fluid escaping under pressure can penetrate skin and cause injury.

WHAT CAN HAPPEN

- Fluid accidentally injected into the skin must be surgically removed within a few hours by a doctor familiar with this form of injury or gangrene may result.

HOW TO AVOID THE HAZARD

- Keep body and hands away from pin hole leaks or nozzles that eject high pressure hydraulic fluid.
- Use cardboard or paper to find hydraulic leaks, never use your hands.

3. Position a drip pan under the hydraulic couplers you are replacing and have several rags ready to wipe up any spills.

4. Thread an adapter into both the new male and female, flush-face couplers (Fig. 1).

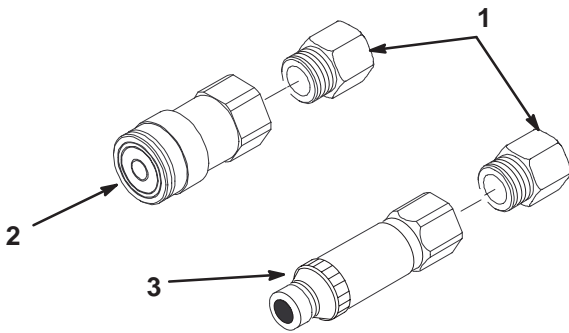

Figure 1

1. Adapter
2. Female, flush-face coupler
3. Male, flush-face coupler

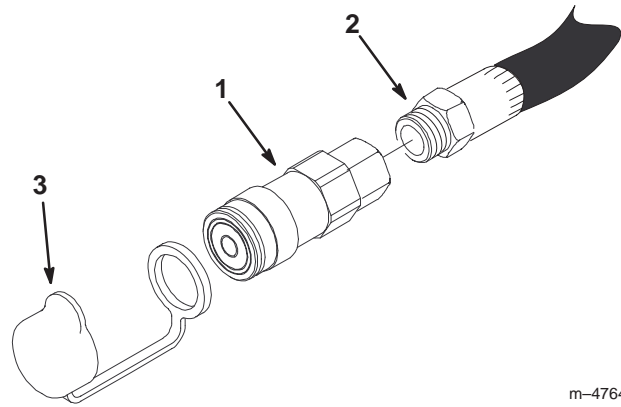

Figure 2

1. Coupler assembly
2. Hose end
3. Protective cover (traction units only)

m-4764

5. Torque the adapter/coupler assemblies to 100 ft-lb (135.6 N·m).
6. Remove the old female coupler from the hose.
7. Install the female coupler assembly onto the hose as follows (refer to Figure 2 during this procedure):

For Kit Number 100-4744 and 100-4750:

- Thread the assembly onto the hose end.
- Torque the assembly to 60 ft-lb (81 N·m).

For Kit Number 100-4746 and 100-4751:

- Thread the assembly onto the hose end.
- Torque the assembly to 67 ft-lb (90 N·m).

For Kit Number 100-4745:

- Clean all old pipe thread sealant from the threads on the hose.
- Apply pipe thread sealant to the hose threads.
Do not apply sealant to the first thread.
- Thread the assembly onto the hose end until it is finger-tight.
- Turn the assembly onto the hose end 2 to 3 complete turns.
- Allow the sealant to cure according to the manufacturer's instruction before using the attachment.

8. Repeat steps 6 and 7 to install the male, flush-face coupler.
9. If you are installing a kit on a traction unit, install the protective covers onto the couplers (Fig. 2).
10. Wipe up any spills.