



Wheel Horse[®]

**32" Easy-Empty[®] Grass Catcher
for Lawn Tractors and Rear Engine Riders**

Model No. 79096—8900001 and Up

Model No. 79096—200000001 and Up

Operator's Manual

Introduction

Thank you for purchasing a Toro product.

All of us at Toro want you to be completely satisfied with your new product, so feel free to contact your local Authorized Service Dealer for help with service, genuine Toro replacement parts, or other information you may require.

Whenever you contact your Authorized Service Dealer or the factory, always know the model and serial numbers of your product. These numbers will help the Service Dealer or Service Representative provide exact information about your specific product. You will find the model and serial number plate located in a unique place on the product as shown below.

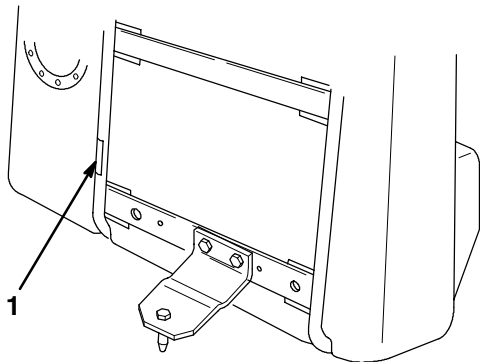

1. Model and Serial Number Plate

For your convenience, write the product model and serial numbers in the space below.

Model No: _____
Serial No. _____

Read this manual carefully to learn how to operate and maintain your product correctly. Reading this manual will help you and others avoid personal injury and damage to the product. Although Toro designs, produces and markets safe, state-of-the-art products, you are responsible for using the product properly and safely. You are also responsible for training persons who you allow to use the product about safe operation.

The Toro warning system in this manual identifies potential hazards and has special safety messages that help you and others avoid personal injury, even death. **DANGER**, **WARNING** and **CAUTION** are signal words used to identify the level of hazard. However, regardless of the hazard, be extremely careful.

DANGER signals an extreme hazard that will cause serious injury or death if the recommended precautions are not followed.

WARNING signals a hazard that may cause serious injury or death if the recommended precautions are not followed.

CAUTION signals a hazard that may cause minor or moderate injury if the recommended precautions are not followed.

Two other words are also used to highlight information. “Important” calls attention to special mechanical information and “Note” emphasizes general information worthy of special attention.

The left and right side of the machine is determined by sitting on the seat in the normal operator’s position.

Contents

	Page		Page
Safety and Instruction Decals	2	Operation	10
Installation	3	Emptying the Grass Basket	10
Loose Parts	3	Clearing Obstructions from Grass Catcher	10
Installing Mounting Assemblies on a Front Engine Lawn Tractor	4	Operating and Bagging Tips	10
Installing Mounting Assemblies on a Rear Engine Rider	5	Maintenance	12
Installing Side Discharge Blade	7	Inspecting the Grass Catcher	12
Assembling and Installing the Grass Basket	7	Inspecting the Mower Blades	12
Removing the Grass Catcher	9	Cleaning the Grass Catcher	12
		Storing the Grass Catcher	12

Safety and Instruction Decals



Safety decals and instructions are easily visible to the operator and are located near any area of potential danger. Replace any decal that is damaged or lost.



ON CHUTE
(Part No. 54-9220)



ON GRASS BASKET
(Part No. 92-2511)

Installation

Loose Parts

DESCRIPTION	QTY.	USE
Upper Mounting Bracket	1	Install upper mounting bracket and hitch plate on a front engine lawn tractor (serial number 3900001 and up)
Bolt (5/16" x 1")	2	
Locknut (5/16")	2	
Hitch Plate	1	
Bolt (5/16" x 1")	2	
Locknut (5/16")	2	
Hitch Pin	1	
Bolt (5/16" x 5/8")	1	
Bagging Brace	1	Install mounting bracket and bagging brace on a rear engine rider with wrap-around stand bars (serial number 3900001 and up)
Mounting Bracket	1	
Bolt (5/16" x 1-3/4")	1	
Locknut (5/16")	4	
Bolt (5/16" x 1-1/2")	3	
Hitch Bracket	1	Install hitch bracket and spacer on a rear engine rider with wrap-around stand bars (serial number 3900001 and up) or a rear engine rider with L-shaped stand bars (serial number 2500001 and down)
Bolt (5/16" x 1")	2	
Locknut (5/16")	2	
Spacer	1	
Bolt (1/4" x 1-3/4")	1	
Locknut (1/4")	1	
32" Blade	1	Install side discharge blade
Deflector Ramp	1	
Deck Baffle	1	
Bolt (5/16" x 3/4")	2	
Locknut (5/16")	2	

Grass Basket with Frame	1	Assemble and install grass catcher
Dump Handle	1	
Bolt (1/4" x 2")	1	
Locknut (1/4")	1	
Washer (1/4")	1	
Hairpin Cotter	2	
Chute	1	Install chute and duct
Duct	1	
Barbed Clip	1	
Retainer	1	
Spacer Fastener	1	
Locking Pin	1	

Installing Mounting Assemblies on a Front Engine Lawn Tractor

If you are installing the grass catcher on a rear engine rider, skip to Installing Mounting Assemblies on a Rear Engine Rider, page 5.

This section describes the procedures for installing the upper mounting bracket, hitch plate, and hitch pin on front engine lawn tractors, serial number 3900001 and up.

Installing the Upper Mounting Bracket

1. Install the upper mounting bracket to the rear of the tractor using two 5/16" x 1" bolts and 5/16" locknuts (Fig. 1)

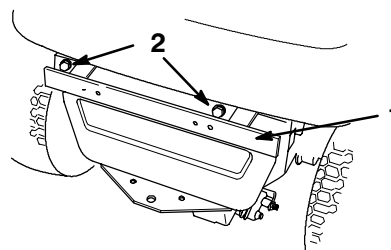

m-3399

Figure 1

1. Upper Mounting Bracket
2. Bolt (5/16" x 1")

Installing the Hitch Plate

1. Align the right hole in the hitch plate tab with the alignment hole on the mounting frame (Fig. 2).
2. Secure the hitch plate to the mounting frame using two 5/16" x 1" bolts and 5/16" locknuts (Fig. 2).
3. Secure the hitch pin into the hole in the hitch plate using a 5/16" x 5/8" bolt (Fig. 2).

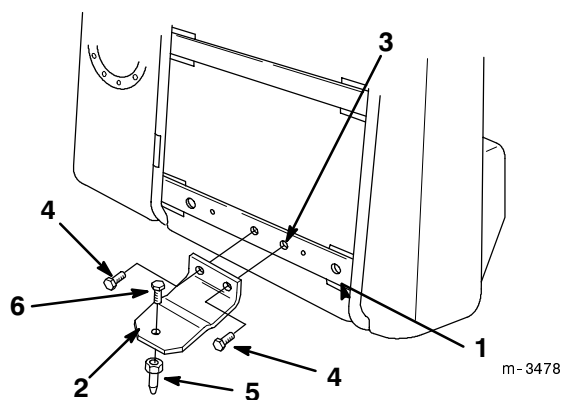

Figure 2

- | | |
|-------------------|------------------------|
| 1. Mounting Frame | 4. Bolt (5/16" x 1") |
| 2. Hitch Plate | 5. Hitch Pin |
| 3. Alignment Hole | 6. Bolt (5/16" x 5/8") |

Installing Mounting Assemblies on a Rear Engine Rider

If you are installing the grass catcher on a lawn tractor, skip to Assembling and Installing the Grass Basket, page 7.

This section describes the procedures for installing the mounting bracket and bagging brace on a rear engine rider with a wrap-around stand bar, serial number 3900001 and up (Fig. 3).

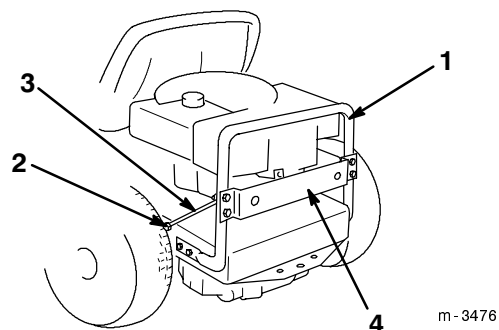

Figure 3

- | | |
|--------------------------|---------------------|
| 1. Wrap-around Stand Bar | 3. Bagging Brace |
| 2. Top Center Bolt | 4. Mounting Bracket |

Also included are instructions for installing the hitch bracket and spacer on a rear engine rider with a wrap-around stand bar, serial number 3900001 and up and on a rear engine rider with L-shaped stand bars, serial number 2500001 and down (Fig. 4).

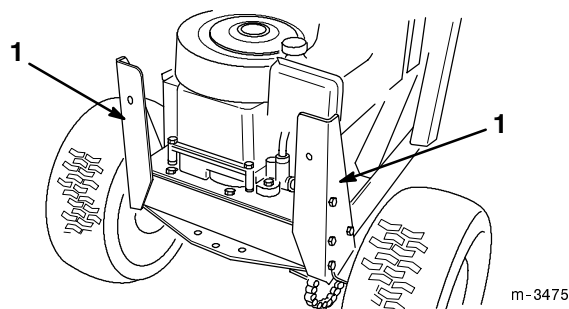

Figure 4

1. L-shaped Stand Bars

Note: If you are installing the grass catcher on a rear engine rider with L-shaped stand bars, skip to Installing Hitch Bracket and Spacer on a Rear Engine Rider, page 6.

Installing Mounting Bracket and Bagging Brace on a Rear Engine Rider with a Wrap-Around Stand Bar (Serial Number 3900001 and Up)

1. Remove the top center bolt from the left side of the rider frame (Fig. 3).
2. Loosely attach the bagging brace to the rider with the bolt removed in step 1 (Fig. 3).
3. Position the mounting bracket across the wrap-around stand bar, aligning the holes in the bracket with the holes in the stand bar (Fig. 3).
4. Secure the upper left corner of the mounting bracket and the brace to the stand bar with a 5/16" x 1-3/4" bolt and 5/16" locknut.
5. Secure the remaining corners of the mounting bracket to the stand bar using 5/16" x 1-1/2" bolts and 5/16" locknuts.
6. Tighten all bolts.

Installing Hitch Bracket and Spacer on a Rear Engine Rider

This section should be used to install the hitch bracket and spacer on rear engine rider with either L-shaped or wrap-around stand bars.

1. Position the hitch bracket on the mounting frame of the grass catcher, aligning the marks on the bracket with those on the mounting frame (Fig. 5).
2. Secure the hitch bracket to the mounting frame with two 5/16" x 1" bolts and 5/16" locknuts (Fig. 5).
3. Mount the spacer to the hitch bracket with a 1/4" x 1-3/4" bolt and 1/4" locknut (Fig. 5).

Note: The spacer should be positioned beneath the bracket.

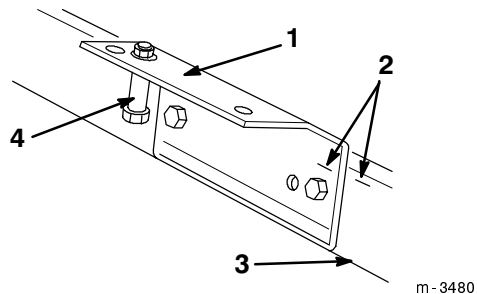

Figure 5

- | | |
|--------------------|--------------------------|
| 1. Hitch Bracket | 3. Bottom Edge of Bagger |
| 2. Alignment Marks | 4. Spacer |

Installing Side Discharge Blade

If your mower deck has a recycling blade installed, it is necessary to add baffles to the deck and replace the blade with a side discharge blade.

1. Remove recycling blade from mower deck. Set hardware aside.
2. Attach the deflector ramp and the deck baffle to the mower deck with two $5/16'' \times 3/4''$ bolts and $5/16''$ locknuts (Fig. 6).
3. Attach side discharge blade with previously removed hardware.

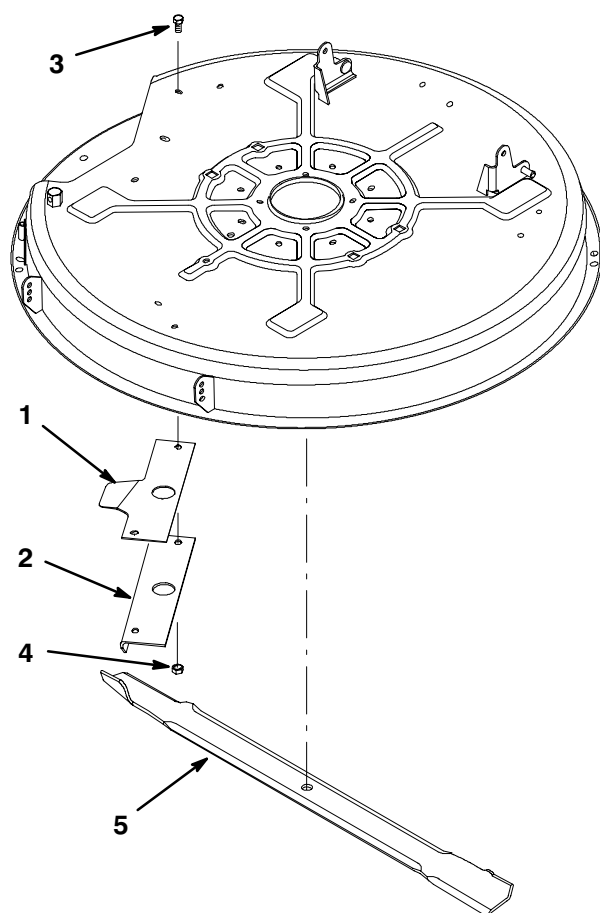
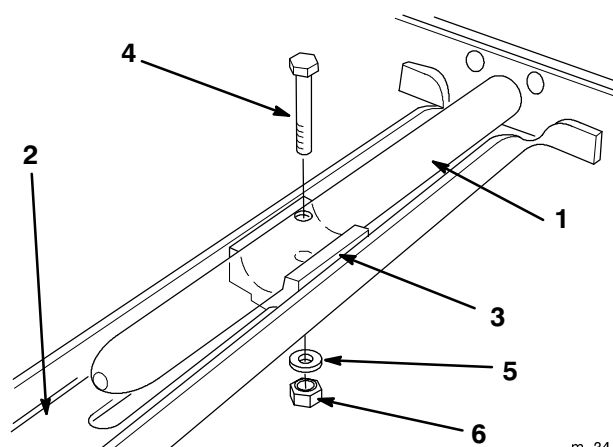

Figure 6

- | | |
|-----------------------------------|-------------------------|
| 1. Deflector ramp | 4. Locknut ($5/16''$) |
| 2. Deck baffle | 5. Side discharge blade |
| 3. Bolt ($5/16'' \times 3/4''$) | |

Assembling and Installing the Grass Basket

1. Open the grass basket and slide the dump handle through the hole in the top of the basket and into the handle channel (Fig. 7). Ensure that the handle grip is positioned so that it will point toward the front of the tractor/rider when installed.
2. Lift up on the end of the dump handle, positioning it on the handle guide in the channel with the holes in the handle and guide aligned (Fig. 7).
3. Secure the handle guide and dump handle to the channel with the $1/4'' \times 2''$ bolt, $1/4''$ washer, and $1/4''$ locknuts (Fig. 7)



m-3416

Figure 7

- | | |
|-------------------|--------------------------------|
| 1. Dump Handle | 4. Bolt ($1/4'' \times 2''$) |
| 2. Handle Channel | 5. Washer ($1/4''$) |
| 3. Handle Guide | 6. Locknut ($1/4''$) |

4. Pull the dump handle up until it stops, then close the grass basket. Push the dump handle down until it stops.

Note: When the dump handle is pushed in completely, the basket should not be able to open. If the basket opens, either the dump handle is not pushed in far enough or the basket is not fully closed.

Attaching the Grass Basket to the Tractor/Rider

1. Insert the hitch pin or spacer on the grass catcher into the mounting hole in the tractor/rider hitch.
2. Rotate the grass catcher up so that the pins on the mounting frame slide through the mounting holes on the tractor/rider. Secure the pins with the hairpin cotters.

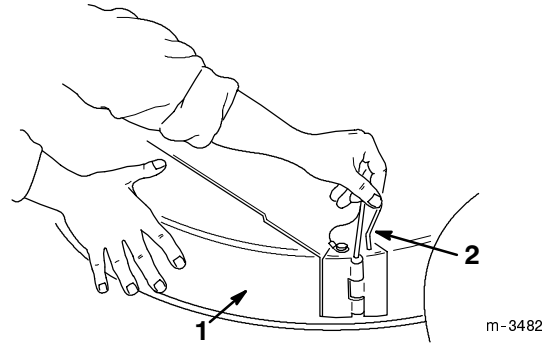

Figure 9

1. Chute
 2. Locking Pin
-

Assembling and Installing the Chute and Duct

1. Secure the retainer to the duct with the barbed clip and spacer fastener (Fig. 9).
2. Slide the duct over the end of the chute, aligning the retainer with the knob on the chute. Pull the retainer over the knob, securing the duct and chute (Fig. 9).

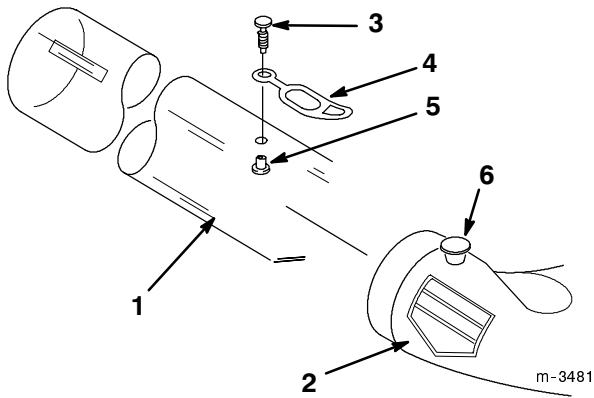

Figure 8

1. Duct
 2. Chute
 3. Barbed Clip
 4. Retainer
 5. Spacer Fastener
 6. Knob
-

3. Slide the duct into the opening in the grass basket.
4. Lift the mower deflector and hook the support bracket on the back of the chute behind the pivot post on the mower.
5. Slide the front of the chute into the locking position on the mower. Insert the locking pin (Fig. 9).

Testing the Installation

1. Pull up on the dump handle and open the grass basket.
2. Close the grass basket completely and push the dump handle down until it stops.
3. Ensure that the grass basket will not open with the dump handle pushed down fully.

Removing the Grass Catcher

DANGER

POTENTIAL HAZARD

- Sometimes people are tempted to operate the mower with the duct and chute removed. This exposes you and others to thrown debris and blade contact.

WHAT CAN HAPPEN

- You and others may die or be injured severely if you are hit by thrown debris or cut by the blade.

HOW TO AVOID THE HAZARD

- Always operate the mower with the complete grass catcher mounted in place or use the mower to side discharge, making sure that the spring-loaded grass deflector is in the down position.

1. Remove the locking pin securing the chute to the mower. Pull the chute out of the mower (Fig. 9).
2. Disconnect the retainer on the duct from the knob on the chute and pull the duct free from the chute and grass basket (Fig. 9).
3. Remove the hairpin cotters securing the grass basket to the upper mounting bracket on the mower. Rock the grass basket backward, then pull it free of the mower hitch.
4. Store all grass catcher parts in a convenient place.

Operation

CAUTION

To Avoid Personal Injury:

- **Become familiar with all operating and safety instructions in the operator's manual for your tractor/rider before using this attachment.**
- **Never remove the grass catcher discharge tube, grass basket, or the chute while the engine is running.**
- **Always shut the engine off before clearing an obstruction from the grass catcher.**
- **Never do maintenance or repairs while the engine is running.**

Emptying the Grass Basket

1. Disengage the mower blades then back the tractor up to the area where you want to dump the grass clippings.
2. Stop the tractor/rider, shift to NEUTRAL, set the parking brake, and shut the engine off.
3. Pull up on the dump handle and swing the grass basket open.
4. Empty the grass basket
5. Close the grass basket completely and push the dump handle down until it stops. Ensure that the grass basket will not open.

Clearing Obstructions from Grass Catcher

1. Stop the tractor, shift to NEUTRAL, set the parking brake, and disengage the mower blades. Shut the engine off before you get off the tractor/rider.

2. Check the grass basket and empty it if full.
3. Remove and separate the duct and chute from the grass basket and mower. Using a stick or similar object, carefully remove and clear the obstruction from the mower, duct, chute, and the grass basket.
4. After you remove the obstruction, install the grass catcher and resume operation.

Operating and Bagging Tips

Size

Remember that the tractor/rider is longer and wider with this attachment installed. By turning too sharply in confined places you may damage the attachment.

Trimming

Always trim with the left side of the mower. Do not trim with the right side of the mower because you could damage the grass catcher's chute and duct.

Cutting Height

Do not set the mower cutting height too low because long grass surrounding the mower can prevent air from getting under the mower and entering the grass catcher. If enough air doesn't get under the mower, the grass catcher will plug.

Cutting Frequency

Cut the grass often, especially when it grows rapidly. You will have to cut your grass twice if it gets excessively long (refer to Catching Long Grass, page 11).

Cutting Technique

For best lawn appearance, be sure to slightly overlap the mower into the previously cut area. This helps reduce the load on the engine and reduces the chance of plugging the grass catcher.

Grass Catching Speed

Most often you will catch grass with the tractor throttle in the FAST position and drive in 1st. gear, which is the slowest ground speed. However, in extremely dry and dusty grass, you may want to lower throttle speed and shift gear selector to a higher gear to maintain ground speed. The grass catcher may plug if you drive too fast, causing the engine to slow down with the extra work load.

CAUTION

POTENTIAL HAZARD

- As the grass basket fills, extra weight is added to the back of the tractor.

WHAT CAN HAPPEN

- If you stop and start suddenly on hills, you may lose steering control or the mower may tip.

HOW TO AVOID THE HAZARD

- Do not start or stop suddenly when going uphill or downhill. Avoid uphill starts.
- If you do stop the mower when going uphill, disengage the mower blades. Then back down the hill using slow reverse speed.
- Do not change speeds or stop on slopes.

Catching Long Grass

Excessively long grass is heavy and may not be propelled completely into the grass basket. If this happens, the duct may plug. To avoid plugging the grass catcher, mow the grass at a high height-of-cut, then lower the mower to your normal cutting height and repeat the process.

Catching Wet Grass

Always try to cut grass when it is dry because your lawn will have a neat appearance. If you must cut wet grass, use the conventional side discharge feature of the mower. Several hours later, when the clippings are dry, install the grass catcher and vacuum up the grass clippings.

Signs of Plugging

As you are cutting grass, a small amount of grass clippings normally blow out the front of the mower. An excessive amount of clipping blow-out indicates that the basket is full or the system is plugged.

Maintenance

Inspecting the Grass Catcher

Inspect the grass catcher after the first ten hours of operation and monthly thereafter.

1. Check the duct, chute, and the grass basket. Replace these parts if they are cracked or broken.
2. Tighten all nuts bolts and screws.

Inspecting the Mower Blades

1. Inspect the mower blades regularly and whenever a blade strikes a foreign object.
2. If blades are badly worn or damaged, install new blades. Refer to your mower operator's manual for complete blade maintenance.

Cleaning the Grass Catcher

1. After each use, remove and wash the inside and outside of the grass basket, duct, chute, and the underside of the mower, using water sprayed from a garden hose. Use a mild automotive detergent to remove stubborn dirt.

CAUTION

POTENTIAL HAZARD

- If you store grass clippings in the grass basket, under the right conditions, spontaneous combustion (a fire-generating process that occurs without an external source of ignition) could occur.

WHAT CAN HAPPEN

- If a fire occurs, property could be damaged and/or someone could be injured.

HOW TO AVOID THE HAZARD

- The grass basket is not a storage container. Never store grass clippings and debris in the grass basket.

2. Make sure you remove matted grass from all parts.
3. After washing let all parts dry thoroughly.

Storing the Grass Catcher

1. Clean the grass catcher (refer to Cleaning the Grass Catcher, page 12).
2. Inspect the grass catcher for damage (refer to Inspecting the Grass Catcher, page 12).
3. Store the grass catcher in a clean, dry place, out of direct sunlight. This protects the plastic parts and extends the life of the grass catcher. If you must store the grass catcher outside, cover it with a weatherproof cover.

