



**Z-Master<sup>®</sup>**

**Out Front Z**

**Model No. 74195-20000001 & Up**

**Operator's Manual**

# Introduction

Thank you for purchasing a Toro product.

All of us at Toro want you to be completely satisfied with your new product, so feel free to contact your local Authorized Service Dealer for help with service, genuine replacement parts, or other information you may require.

Whenever you contact your Authorized Service Dealer or the factory, always know the model and serial numbers of your product. These numbers will help the Service Dealer or Service Representative provide exact information about your specific product. You will find the model and serial number plate located in a unique place on the product as shown below.

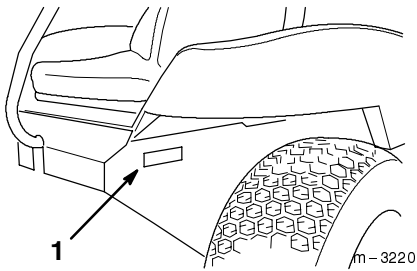

1. Model and Serial Number Plate

For your convenience, write the product model and serial numbers in the space below.

<b>Model No.</b> _____
<b>Serial No.</b> _____

Read this manual carefully to learn how to operate and maintain your product correctly. Reading this manual will help you and others avoid personal injury and damage to the product. Although we design, produce and market safe, state-of-the-art products, you are responsible for using the product properly and safely. You are also responsible for training persons, who you allow to use the product, about safe operation.

The warning system in this manual identifies potential hazards and has special safety messages that help you and others avoid personal injury, even death. DANGER, WARNING and CAUTION are signal words used to identify the level of hazard. However, regardless of the hazard, be extremely careful.

**DANGER** signals an extreme hazard that will cause serious injury or death if the recommended precautions are not followed.

**WARNING** signals a hazard that may cause serious injury or death if the recommended precautions are not followed.

**CAUTION** signals a hazard that may cause minor or moderate injury if the recommended precautions are not followed.

Two other words are also used to highlight information. “Important” calls attention to special mechanical information and “Note” emphasizes general information worthy of special attention.

The left and right side of the machine is determined from the normal operator’s position.

<b>! WARNING: !</b>
<b>The engine exhaust from this product contains chemicals known to the State of California to cause cancer, birth defects, or other reproductive harm.</b>

**IMPORTANT: This engine is not equipped with a spark arrester muffler. It is a violation of California Public Resource Code Section 4442 to use or operate this engine on any forest-covered, brush-covered or grass-covered land. Other states or federal areas may have similar laws.**

# Contents

	<b>Page</b>		<b>Page</b>
Safety .....	3	Maintenance .....	35
Gasoline and Oil .....	12	Service Interval Chart .....	35
Recommended Gasoline .....	12	Cutting Blades .....	36
Using Stabilizer/Conditioner .....	13	Correcting Cutting Unit Mismatch .....	39
Filling the Fuel Tank .....	13	Matching Height of Cut .....	39
Check Engine Oil Level .....	13	Checking the Front-to-Rear Pitch .....	40
Assembly .....	14	Change the Front-to-Rear Pitch .....	40
Loose Parts .....	14	Checking the Side-to-Side Leveling .....	41
Remove bracket from Rear Tail Wheel ...	15	Change the Side-to-Side Leveling .....	41
Remove Deck Banding .....	15	Air Cleaner .....	42
Check Tire Pressure .....	15	Engine Oil .....	43
Activate the Battery .....	16	Spark Plug .....	45
Install Battery .....	17	Fuel Filter .....	46
Remove Machine from Crate .....	17	Fuel Tank .....	47
Operation .....	18	Cleaning the Cooling Systems .....	48
Think Safety First .....	18	Greasing and Lubrication .....	48
Controls .....	18	Deck Gearbox Fluid .....	49
Parking Brake .....	19	Changing Gearbox Fluid .....	49
Starting and Stopping Engine .....	20	Checking Gearbox Fluid .....	50
Operating Power Take Off (PTO) .....	21	Replacing the Castor Wheel Fork Bushings	50
The Safety Interlock System .....	22	Servicing the Castor Wheels Tail Wheel and	
Instruments .....	22	Bearings .....	51
Driving Forward or Backward .....	23	Tire Pressure .....	52
Stopping the Machine .....	23	Replacing Push Arm Bushings .....	52
Positioning the Seat .....	24	Hydraulic System .....	53
Adjusting Height-of-Cut .....	24	Adjust Motion Controls .....	55
Tilting the Mower .....	25	Replacing Power Take Off (PTO) Belts ...	56
Dumping the Hopper .....	26	Replacing the Traction Belt .....	57
Pushing the Machine by Hand .....	26	Replacing the Blower Belt .....	57
Removing the Deck and Carrier Frame ...	27	Fuse .....	58
Installing Deck and Carrier Frame .....	29	Turning Engine Lift Hook .....	58
Install Mulching Baffle .....	32	Battery .....	59
Mulching Operation .....	32	Cleaning Hopper Screens .....	60
Install Bagger and Discharge Baffles .....	33	Cleaning the Hopper Full Sensor .....	60
Bagger Operation .....	33	Wiring Diagram .....	61
Plenum Removal and Installation .....	34	Hydraulic Diagram .....	62
		Cleaning and Storage .....	63

Troubleshooting ..... 64

**The enclosed Engine Owner’s Manual is supplied for information regarding The U.S. Environmental Protection Agency (EPA) and the California Emission Control Regulation of emission systems, maintenance and warranty.**

**Keep this engine Owner’s Manual with your unit. Should this engine Owner’s Manual become damaged or illegible, replace immediately. Replacements may be ordered through the engine manufacturer.**

# Safety

## Safe Operation Practices for Ride-on (riding) Rotary Lawnmower Machines

**This machine meets or exceeds European Standards in effect at the time of production. However, improper use or maintenance by the operator or owner can result in injury. To reduce the potential for injury, comply with these safety instructions and always pay attention to the safety alert ▲ symbol, which means CAUTION, WARNING, or DANGER—“personal safety instruction.” Failure to comply with the instruction may result in personal injury or death.**

## Safe Operating Practices

The following instructions are from the CEN standard EN 836:1997.

This product is capable of amputating hands and feet and throwing objects. Always follow all safety instructions to avoid serious injury or death.

### Training

- Read the instructions carefully. Be familiar with the controls and the proper use of the equipment.
- Never allow children or people unfamiliar with these instructions to use the lawnmower. Local regulations can restrict the age of the operator.
- Never mow while people, especially children, or pets are nearby.
- Keep in mind that the operator or user is responsible for accidents or hazards occurring to other people or their property.
- Do not carry passengers.

- All drivers should seek and obtain professional and practical instruction. Such instruction should emphasize:
  - the need for care and concentration when working with ride-on machines;
  - control of a ride-on machine sliding on a slope will not be regained by the application of the brake. The main reasons for loss of control are:
    - insufficient wheel grip;
    - being driven too fast;
    - inadequate braking;
  - the type of machine is unsuitable for its task;
  - lack of awareness of the effect of ground conditions, especially slopes;
  - incorrect hitching and load distribution.

### Preparation

- While mowing, always wear substantial footwear and long trousers. Do not operate the equipment when barefoot or wearing open sandals.
- Thoroughly inspect the area where the equipment is to be used and remove all objects which may be thrown by the machine.
- **WARNING - Fuel is highly flammable.**
  - Store fuel in containers specifically designed for this purpose.
  - Refuel outdoors only and do not smoke while refuelling.

- Add fuel before starting the engine. Never remove the cap of the fuel tank or add fuel while the engine is running or when the engine is hot.
- If fuel is spilled, do not attempt to start the engine but move the machine away from the area of spillage and avoid creating any source of ignition until fuel vapors have dissipated.
- Replace all fuel tanks and container caps securely.
- Replace faulty silencers.
- Before using, always visually inspect to see that the blades, blade bolts and cutter assembly are not worn or damaged. Replace worn or damaged blades and bolts in sets to preserve balance.
- On multi-bladed machines, take care as rotating one blade can cause other blades to rotate.
- engage clutch slowly, always keep machine in gear, especially when travelling downhill;
- machine speeds should be kept low on slopes and during tight turns;
- stay alert for humps and hollows and other hidden hazards;
- never mow across the face of the slope, unless the lawnmower is designed for this purpose.
- Use care when pulling loads or using heavy equipment.
- Use only approved drawbar hitch points.
- Limit loads to those you can safely control.
- Do not turn sharply. Use care when reversing.
- Use counterweight(s) or wheel weights when suggested in the instruction handbook.
- Watch out for traffic when crossing or near roadways.
- Stop the blades rotating before crossing surfaces other than grass.
- When using any attachments, never direct discharge of material toward bystanders nor allow anyone near the machine while in operation.
- Never operate the machine with defective guards or without safety protective devices in place.
- Do not change the engine governor settings or overspeed the engine. Operating the engine at excessive speed can increase the hazard of personal injury.
- Before leaving the operator's position:
  - disengage the power take-off and lower the attachments;

## Operation

- Do not operate the engine in a confined space where dangerous carbon monoxide fumes can collect.
- Mow only in daylight or in good artificial light.
- Before attempting to start the engine, disengage all blade attachment clutches and shift into neutral.
- Do not use on slopes of more than
  - 5° when mowing on side hills;
  - 10° when mowing uphill;
  - 15° when mowing downhill.
- Remember there is no such thing as a “safe” slope. Travel on grass slopes requires particular care. To guard against overturning:
  - do not stop or start suddenly when going up or downhill;

- change into neutral and set the parking brake;
- stop the engine and remove the key.
- Disengage drive to attachments, stop the engine, and disconnect the spark plug wire(s) or remove the ignition key
  - before clearing blockages or unclogging chute;
  - before checking, cleaning or working on the lawnmower;
  - after striking a foreign object. Inspect the lawnmower for damage and make repairs before restarting and operating the equipment;
  - if the machine starts to vibrate abnormally (check immediately).
- Disengage drive to attachments when transporting or not in use.
- Stop the engine and disengage drive to attachment
  - before refuelling;
  - before removing the grass catcher;
  - before making height adjustment unless adjustment can be made from the operator's position.
- Reduce the throttle setting during engine run-out and, if the engine is provided with a shut-off valve, turn the fuel off at the conclusion of mowing.
- Allow the engine to cool before storing in any enclosure.
- To reduce the fire hazard, keep the engine, silencer, battery compartment and fuel storage area free of grass, leaves, or excessive grease.
- Check the grass catcher frequently for wear or deterioration.
- Replace worn or damaged parts for safety.
- If the fuel tank has to be drained, this should be done outdoors.
- On multi-bladed machines, take care as rotating one blade can cause other blades to rotate.
- When machine is to be parked, stored or left unattended, lower the cutting means unless a positive mechanical lock is used.

## Toro Riding Mower Safety

The following list contains safety information specific to Toro products or other safety information that you must know that is not included in the CEN standard.

- Use only Toro-approved attachments. Warranty may be voided if used with unapproved attachments.

## Maintenance and Storage

- Keep all nuts, bolts and screws tight to be sure the equipment is in safe working condition.
- Never store the equipment with fuel in the tank inside a building where fumes can reach an open flame or spark.

## **Sound Pressure Level**

This unit has an equivalent continuous A-weighted sound pressure at the operator ear of: XX dB(A), based on measurements of identical machines per procedures outlined in Directive 84/538/EEC and amendments.

## **Sound Power Level**

This unit has a sound power level of: XXX Lwa, based on measurements of identical machines per procedures outlined in Directive 84/538/EEC and amendments.

## **Vibration Level**

This unit has a maximum hand-arm vibration level of 4.0 m/s<sup>2</sup> and whole body vibration level of XX m/s<sup>2</sup>, based on measurements of identical machines per EN 1033 and EN 1032.

# Slope Chart

Read all safety instructions on pages 3-NO TAG.

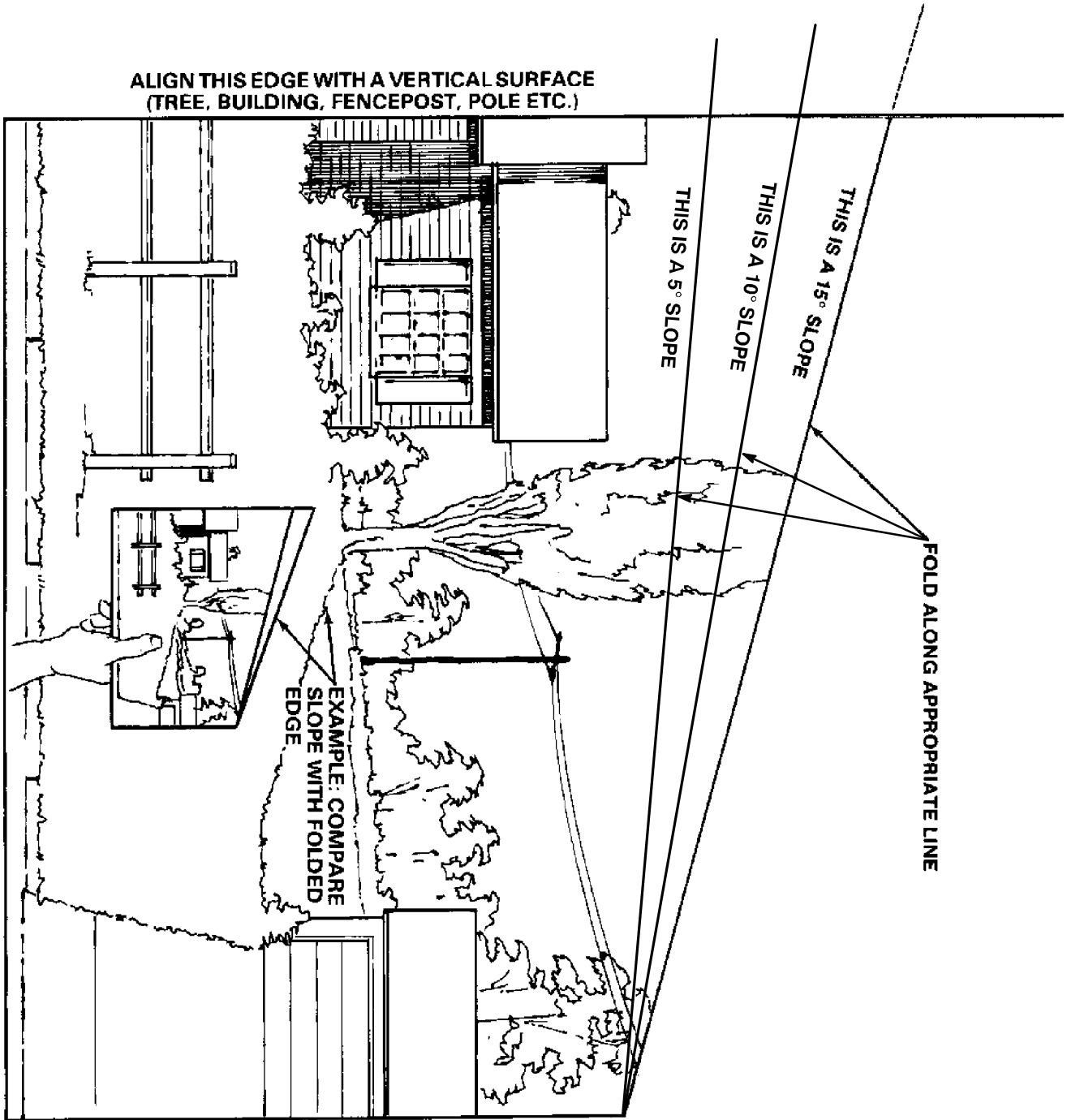



# Symbols Glossary

Safety alert triangle-  
symbol within triangle  
indicates a hazard



Fire, open light & smoking  
prohibited



Safety alert symbol



Fire or open flame



Read operator's manual



Explosion



Consult technical manual  
for proper service procedures



Keep children away  
from battery



Shut off engine & remove  
key before performing  
maintenance or repair work



Do not dispose of lead  
battery in garbage



Caustic liquids, chemical  
burns to fingers or hand



Stay a safe distance  
from the machine

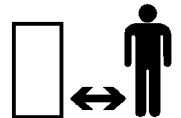

Caution, toxic risk



Stay a safe distance  
from the machine

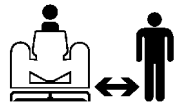

Eye protection must  
be worn



Stay safe distance  
from machine, out front Z

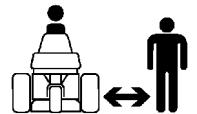

Hearing protection must  
be worn



First aid, flush with water



Keep children a safe  
distance from machine



# Symbols Glossary

Do not open or remove safety shields while engine is running

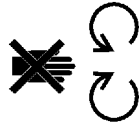

Stored energy hazard, kickback or upward motion



Thrown or flying objects, whole body exposure



Dismemberment, rider backing



Thrown or flying objects, whole body exposure



Do not carry passengers



Keep guards and safety shields in place

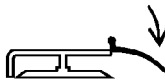

Dismemberment, Out Front Z in forward motion



Severing of toes & fingers, rotary mower blade



Machine rollover, Out Front Z



Hand & arm engagement, belt drive



Machine rollover, do not use on side hill slope greater than 5 degrees



Whole body entanglement, implement input drive line



Machine rollover, do not use on down hill slope greater than 10 degrees



Finger & hand engagement, belt drive



Machine rollover, do not use on up hill slope greater than 15 degrees



Hot surface, burns to fingers or hands



Blade cutting element-height adjustment





















Severing of fingers or hand-engine fan



Blade retaining bolts must be Torqued to 115-149 N.m



# Symbols Glossary

Fast		Brake system	
Slow		Parking brake	
Decreasing/Increasing		Battery	
On/Run		Oil Lubrication Point	
Off/stop		Power take off (PTO)	
Engine start		Engage	
Engine run		Disengage	
Engine stop		Elapsed Operating Hours	
Choke		Alarm	

# Gasoline and Oil

## Recommended Gasoline

Use UNLEADED Regular Gasoline suitable for automotive use (85 pump octane minimum). Leaded regular gasoline may be used if unleaded regular is not available.

**IMPORTANT:** Never use methanol, gasoline containing methanol, or gasohol containing more than 10% ethanol because the fuel system could be damaged. Do not mix oil with gasoline.

### DANGER

#### POTENTIAL HAZARD

- In certain conditions gasoline is extremely flammable and highly explosive.

#### WHAT CAN HAPPEN

- A fire or explosion from gasoline can burn you, others, and cause property damage.

#### HOW TO AVOID THE HAZARD

- Fill the fuel tank outdoors, in an open area, when the engine is cold. Wipe up any gasoline that spills.
- Do not fill the fuel tank completely full. Add gasoline to the fuel tank until the level is 1/4" to 1/2" (6 mm to 13 mm) below the bottom of the filler neck. This empty space in the tank allows gasoline to expand.
- Never smoke when handling gasoline, and stay away from an open flame or where gasoline fumes may be ignited by a spark.
- Store gasoline in an approved container and keep it out of the reach of children. Never buy more than a 30-day supply of gasoline.

### DANGER

#### POTENTIAL HAZARD

- In certain conditions gasoline is extremely flammable and highly explosive.

#### WHAT CAN HAPPEN

- A fire or explosion from gasoline can burn you, others, and cause property damage.

#### HOW TO AVOID THE HAZARD

- Always place gasoline containers on the ground away from your vehicle before filling.
- Do not fill gasoline containers inside a vehicle or on a truck or trailer bed because interior carpets or plastic truck bed liners may insulate the container and slow the loss of any static charge.
- When practical, remove gas-powered equipment from the truck or trailer and refuel the equipment with its wheels on the ground.
- If this is not possible, then refuel such equipment on a truck or trailer from a portable container, rather than from a gasoline dispenser nozzle.
- If a gasoline dispenser nozzle must be used, keep the nozzle in contact with the rim of the fuel tank or container opening at all times until fueling is complete.

**! WARNING****POTENTIAL HAZARD**

- Gasoline is harmful or fatal if swallowed. Long-term exposure to vapors has caused cancer to laboratory animals.

**WHAT CAN HAPPEN**

- Failure to use caution may result in serious injury or illness

**HOW TO AVOID THE HAZARD**

- Avoid prolonged breathing of vapors.
- Keep face away from nozzle and gas tank or conditioner opening.
- Keep gas away from eyes and skin.

## Using Stabilizer/Conditioner

Use a fuel stabilizer/conditioner in the machine to provide the following benefits:

- Keeps gasoline fresh during storage of 90 days or less. For longer storage it is recommended that the fuel tank be drained.
- Cleans the engine while it runs
- Eliminates gum-like varnish buildup in the fuel system, which causes hard starting

**IMPORTANT: Do not use fuel additives containing methanol or ethanol.**

Add the correct amount of gas stabilizer/conditioner to the gas.

**Note:** A fuel stabilizer/conditioner is most effective when mixed with fresh gasoline. To minimize the chance of varnish deposits in the fuel system, use fuel stabilizer at all times.

## Filling the Fuel Tank

1. Shut the engine off and set the parking brake.
2. Clean around each fuel tank cap and remove the cap. Add unleaded regular gasoline to both fuel tanks, until the level is 1/4 to 1/2 inch (6 mm to 13 mm) below the bottom of the filler neck. This space in the tank allows gasoline to expand. Do not fill the fuel tanks completely full.
3. Install fuel tank caps securely. Wipe up any gasoline that may have spilled.

## Check Engine Oil Level

Before you start the engine and use the machine, check the oil level in the engine crankcase; refer to Checking Oil Level, page 44.

# Assembly

## Loose Parts

**Note:** Use the chart below to verify all parts have been shipped.

DESCRIPTION	QTY.	USE
Key	2	Ignition
Safety Booklet	1	Read before operating machine
Operator's Manual	1	Read before operating machine
Engine Operator's Manual	1	Read before operating machine
Parts Catalog	1	For ordering parts
Registration card	1	Fill out and return to Toro
Mulching Baffle	1	For Mulching Mode

## Remove bracket from Rear Tail Wheel

The tail wheel may be fastened to the machine two different ways. Follow the directions that describe the tail wheel fastener on your machine. It is fastened by a bolt or threaded rod.

### Bolt Fastener

The tail wheel fastened with a bolt will have the bolt head on one side and a locknut only on the other side.

1. Remove locknut from bolt that fastens crate bracket to tail wheel. (Fig. 1).
2. Remove crate bracket from wheel bolt. Install locknut on to bolt until fork clamps onto spacer (Fig. 1).

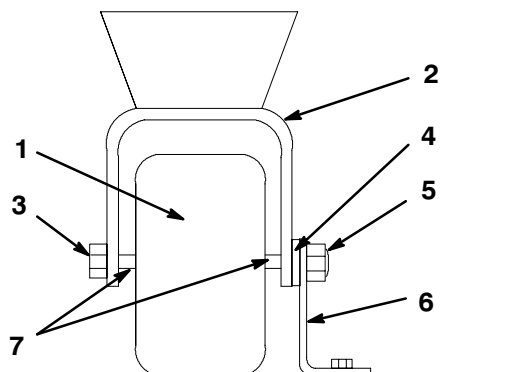

**Figure 1**

- |               |                  |
|---------------|------------------|
| 1. Tail Wheel | 5. Locknut       |
| 2. Fork       | 6. Crate Bracket |
| 3. Bolt Head  | 7. Spacer        |
| 4. Washer     |                  |

m-4859

### Threaded Rod Fastener

The tail wheel fastened with a threaded rod will have two nuts on one side and a locknut on the other side.

1. Remove jam nut from threaded rod that fastens crate bracket to tail wheel. (Fig. 2).
2. Remove crate bracket from wheel bolt. (Fig. 2).
3. Install jam nut back onto threaded rod. (Fig. 2).

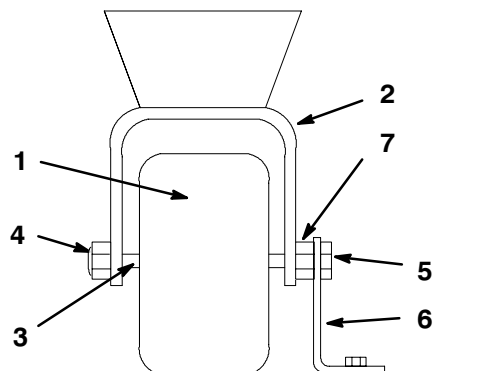

m-4860

**Figure 2**

- |                 |                  |
|-----------------|------------------|
| 1. Tail Wheel   | 5. Jam Nut       |
| 2. Fork         | 6. Crate Bracket |
| 3. Threaded Rod | 7. Nut           |
| 4. Locknut      |                  |

## Remove Deck Banding

Remove any tie down banding that holds deck in place.

## Check Tire Pressure

Check the air pressure in all tires. Refer to Tire Pressure in Maintenance section on page 52.

## Activate the Battery

Bulk electrolyte with 1.260 specific gravity must be purchased from a local battery supply outlet.

1. Remove the battery from the machine.

**IMPORTANT:** Be careful not to damage the long vent tube when removing the battery box.

### WARNING

#### POTENTIAL HAZARD

- Battery electrolyte contains sulfuric acid which is a deadly poison and it causes severe burns.

#### WHAT CAN HAPPEN

- If you carelessly drink electrolyte you could die or if it gets onto your skin you will be burned.

#### HOW TO AVOID THE HAZARD

- Do not drink electrolyte and avoid contact with skin, eyes or clothing. Wear safety glasses to shield your eyes and rubber gloves to protect your hands.
- Fill the battery where clean water is always available for flushing the skin.
- Follow all instructions and comply with all safety messages on the electrolyte container.

2. Remove filler caps from the battery. Slowly pour electrolyte into each cell until the electrolyte level is up to the lower part of the tube (Fig. 3).

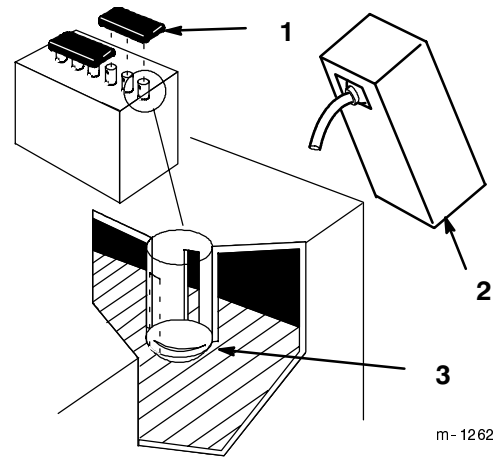

Figure 3

1. Filler caps
2. Electrolyte
3. Lower part of the tube

3. Leave the covers off and connect a 3 to 4 amp battery charger to the battery posts (Fig. 4). Charge the battery at a rate of 4 amperes or less for 4 hours (12 volts).

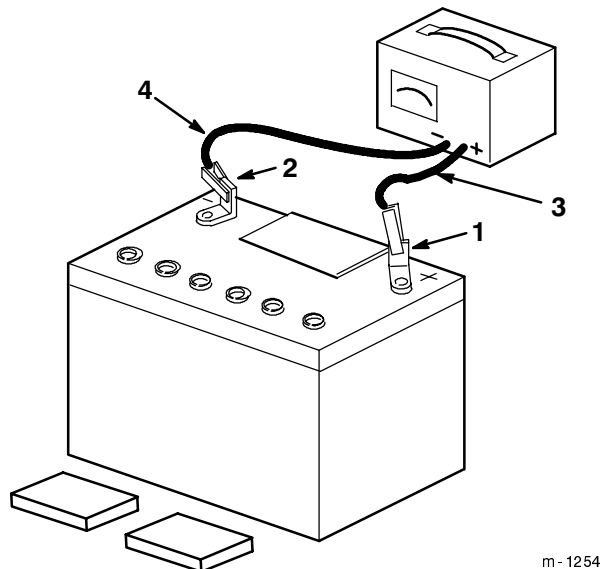

Figure 4

1. Positive post
2. Negative post
3. Charger red (+) wire
4. Charger black (-) wire

**! WARNING**

**POTENTIAL HAZARD**

- Charging battery produces gasses.

**WHAT CAN HAPPEN**

- Battery gasses can explode.

**HOW TO AVOID THE HAZARD**

- Keep cigarettes, sparks and flames away from battery.

4. When the battery is fully charged, disconnect the charger from the electrical outlet then from the negative and positive battery posts (Fig. 4).
5. Slowly pour electrolyte into each cell until the level is once again up to the "UPPER" line on the battery case (Fig. 3) and install covers.

## Install Battery

1. Fill battery with electrolyte and charge, refer to BATTERY, page 59.
2. Position battery in tray with terminal posts toward the engine (Fig. 5).
3. Secure battery with (2) support rods, a battery clamp and (2) 1/4" wing nuts. Position support rods in mounting holes (Fig. 5). Tighten wing nuts so battery is held securely in position and will not slide. **DO NOT OVERTIGHTEN.**
4. Install the positive (red) battery cable to positive (+) battery terminal then negative battery cable to the negative (-) battery terminal. Secure cables with (2) 1/4" x 19 mm (3/4") bolts 1/4", washers, and 1/4" locknuts.

**IMPORTANT: Route cables so they do not contact metal edges, frame members or tailwheel.**

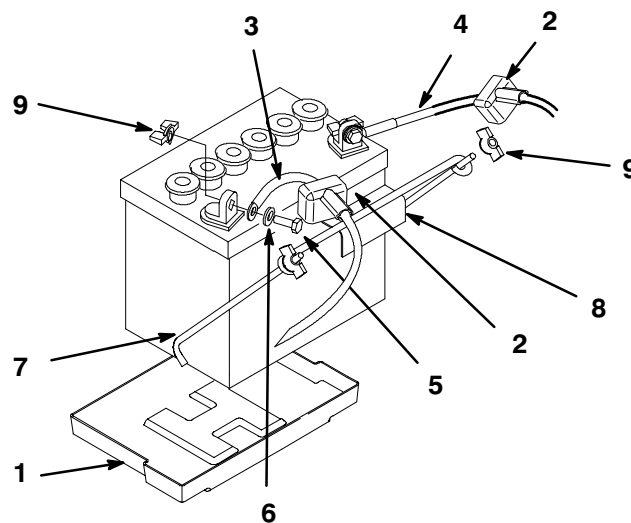

m-4886

**Figure 5**

- |                               |                        |
|-------------------------------|------------------------|
| 1. Battery tray               | 6. Washer 1/4"         |
| 2. Terminal boot              | 7. Battery support rod |
| 3. Positive battery cable     | 8. Battery clamp       |
| 4. Negative battery cable     | 9. Wing nut 1/4"       |
| 5. Bolt 1/4-20 x 3/4" (19 mm) |                        |

## Remove Machine from Crate

1. Tilt deck down and latch into position.
2. Machine can now be driven forward off crate (Fig. 5).

# Operation

## Think Safety First

Please carefully read all the safety instructions on pages 3-8. Knowing this information could help you, your family, pets or bystanders avoid injury.

The use of protective equipment, such as but not limited to, for eyes, ears, feet and head is recommended.

 **CAUTION**

**POTENTIAL HAZARD**

- This machine produces sound levels in excess of 85dBA at the operators ear when in operation.

**WHAT CAN HAPPEN**

- Exposure to sound levels of 85dBA or above for extended periods of time can cause ear damage of hearing loss.

**HOW TO AVOID THE HAZARD**

- Wear hearing protection when operating this machine.

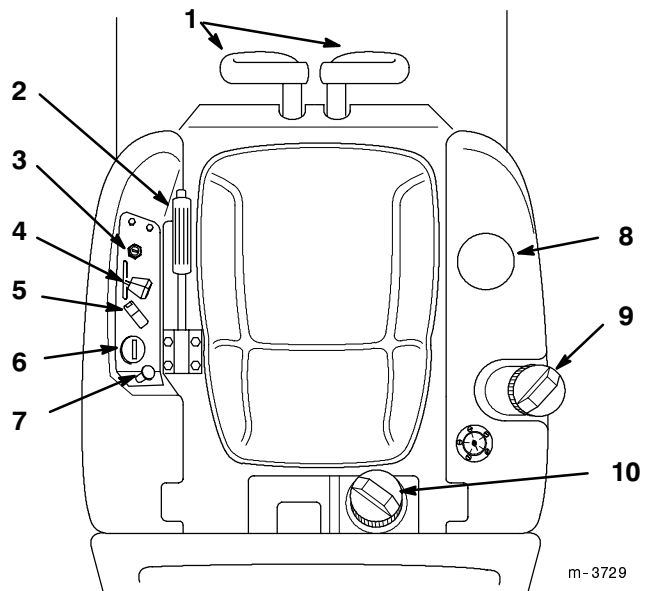

**Figure 6**

1. Caution                      2. Wear hearing protection

## Controls

Become familiar with all the controls before you start the engine and operate the machine (Fig. 7).



**Figure 7**

- |                         |                         |
|-------------------------|-------------------------|
| 1. Motion control lever | 6. Hourmeter            |
| 2. Parking brake        | 7. Choke                |
| 3. Ignition switch      | 8. Drink holder         |
| 4. Throttle             | 9. Fuel cap             |
| 5. Power take off (PTO) | 10. Hydro reservoir cap |

## Parking Brake

Always set the parking brake when you stop the machine or leave it unattended.

### Setting the Parking Brake

1. Move the motion control levers to neutral (Fig. 7).
2. Pull up on the parking brake lever to set the parking brake (Fig. 8). The parking brake lever should stay firmly in the “SET” position.

### Releasing the Parking Brake

1. Push in on the button and lower parking brake lever to “OFF” (Fig. 8).

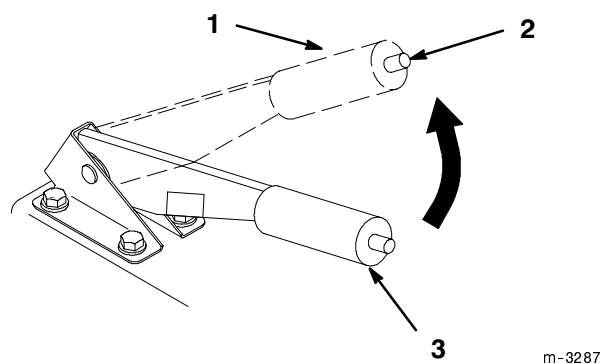

**Figure 8**

- |                      |                      |
|----------------------|----------------------|
| 1. Parking brake-SET | 3. Parking brake-OFF |
| 2. Button            |                      |

## Starting and Stopping Engine

### Starting

1. Sit down on the seat and set the parking brake; refer to Setting the Parking Brake, page 19.
2. Move the motion control levers to neutral.
3. Move the PTO (power take off) switch to “OFF” (Fig. 9).
4. Move the throttle control midway between “SLOW” and “FAST” positions before starting a cold engine.
5. Move the choke control to “ON” position before starting a cold engine.

**Note:** A warm or hot engine may require choking. After engine starts, move choke control to “OFF” position.

6. Turn ignition key to “START” to energize starter. When engine starts, release key.

**Note:** If starter does not crank, move the motion control levers slightly forward or backward to locate neutral.

**IMPORTANT: Do not engage starter for more than 10 seconds at a time. If engine fails to start allow 30 second cool-down period between attempts. Failure to follow these instructions can burn out starter motor.**

7. After the engine starts, gradually move the choke to “OFF” (Fig. 10). If the engine stalls or hesitates, move the choke back to “ON” for a few seconds. Then move the throttle lever to desired setting. Repeat this as required.

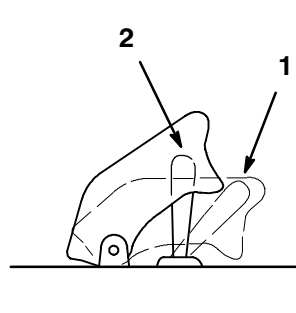

m-2721

**Figure 9**

1. PTO-Off
2. PTO-On

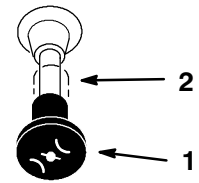

m-2719

**Figure 10**

1. Choke-On
2. Choke-Off

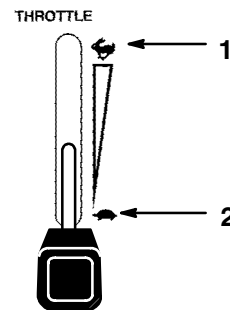

m-

**Figure 11**

1. Fast
2. Slow

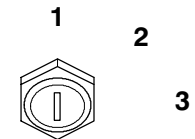

m-2718

**Figure 12**

1. Off
2. Run
3. Start

## Stopping

1. Move the throttle lever to “SLOW” (Fig. 11).
2. Set the parking brake.
3. Turn the ignition key to “OFF” (Fig. 12).

**Note:** If the engine has been working hard or is hot, let it idle for a minute before turning the ignition key “OFF.” This helps cool the engine before it is stopped. In an emergency, the engine may be stopped by turning the ignition key to “OFF” immediately.

4. Pull wire off spark plug(s) to prevent possibility of accidental starting before transporting or storing machine.
5. Close fuel shut off valve under fuel tank before transporting or storing machine.

**IMPORTANT:** Make sure fuel shut off valve is closed before transporting or storing machine, as fuel leakage may occur.

## Operating Power Take Off (PTO)

The power take off (PTO) switch engages and disengages power to the attachment clutch (mower blades).

### Engaging the Power Take Off (PTO)

1. With engine running, move motion control levers to neutral to stop the machine.
2. To prevent engine stalling, from heavy load, move throttle to “FAST” position.
3. Raise the cover and move the power take off (PTO) switch to the “ON” position to engage (Fig. 13).

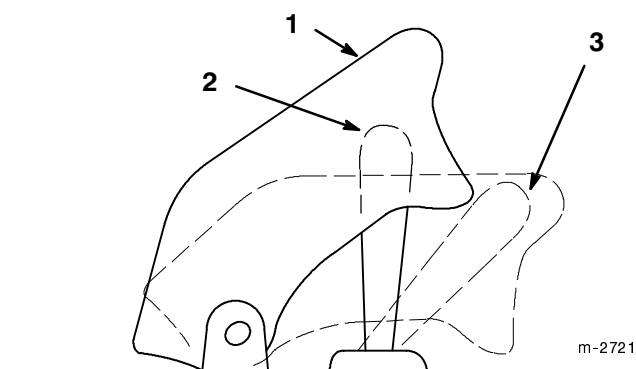

**Figure 13**

- |               |                   |
|---------------|-------------------|
| 1. Cover      | 3. OFF-Disengaged |
| 2. ON-Engaged |                   |

### Disengaging the Power Take Off (PTO)

1. Move motion control levers to neutral to stop the machine.
2. Lower the cover of the power take off (PTO) switch. This moves the switch to the “OFF” position to disengage (Fig. 13).

## The Safety Interlock System

### Understanding the Safety Interlock System

The safety interlock system is designed to prevent the engine from starting unless:

- The parking brake is “SET”
- The power take off (PTO) is disengaged “OFF”
- The motion control levers are in neutral position

The safety interlock system also is designed to stop the engine when:

- The motion control levers are moved out of neutral with the parking brake on “SET”
- You rise from the seat when the power take off (PTO) is “ON” or the motion control levers are not in neutral
- The motion control levers are moved out of neutral or PTO is engaged with the hopper tilted up

### Testing the Safety Interlock System

Test the safety interlock system before you use the machine each time. If the safety system does not operate as described below, have an Authorized Service Dealer repair the safety system immediately.

1. “SET” the parking brake and move power take off (PTO) to “ON”. Try starting the engine; the engine should not crank.
2. “SET” the parking brake and move power take off (PTO) to “OFF”. Move one then the other motion control lever forward or reverse. Try starting the engine; the engine should not crank.
3. “SET” the parking brake, move power take off (PTO) to “OFF” and hold the motion control levers in neutral. Now start the engine. While the engine is running engage the power take off (PTO) and rise slightly from the seat; the engine should stop.

4. “SET” the parking brake, move power take off (PTO) to “OFF” and hold the motion control levers in neutral. Now start the engine. While the engine is running, move the motion control levers forward or reverse; the engine should stop.
5. Tilt the hopper up, “SET” the parking brake, move power take off (PTO) to “OFF” and hold the motion control levers in neutral. Now start the engine. While the engine is running, move the motion control levers forward or reverse; the engine should stop.

## Instruments

### Hour Meter

The hour meter records the number of hours the engine has operated. It operates when the engine is running. Use these times for scheduling regular maintenance.

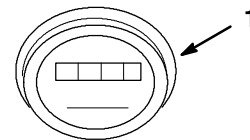

m-2717

**Figure 14**

1. Hour meter
-

## Driving Forward or Backward

The throttle control regulates the engine speed as measured in rpm (revolutions per minute). Place the throttle control in the “FAST” position for best attachment performance. Always operate in the full throttle position when operating attachments.

### Forward

1. Release the parking brake; refer to Setting the Parking Brake, page 19.
2. To go forward, slowly push the motion control levers forward (Fig. 15).

**Note:** Engine will kill if motion control levers are moved with parking brake engaged.

To go straight, move both motion control levers the same distance (Fig. 15).

To turn move the motion control lever toward neutral, on the side you want to turn toward (Fig. 15).

The farther you move the motion control levers in either direction, the faster the machine will move in that direction.

To slow or stop move the motion control levers to neutral.

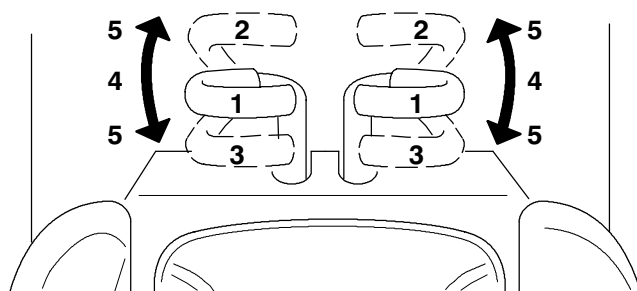

m-3288

**Figure 15**

- |  |             |
|--|-------------|
| 1. Motion control lever-neutral position | 3. Backward |
| 2. Forward                               | 4. Slow     |
|  | 5. Fast     |

### Backward

1. Release the parking brake; refer to Setting the Parking Brake, page 19.
2. To go backward, slowly pull the motion control levers rearward (Fig. 15).

To go straight, move both motion control levers the same distance (Fig. 15).

To turn move the motion control lever toward neutral, on the side you want to turn toward (Fig. 15).

To slow or stop move the motion control levers to neutral.

## Stopping the Machine

To stop the machine, move the motion control levers to neutral, disengage the power take off (PTO), and turn the ignition key to “OFF” to stop the engine. Also set the parking brake when you leave the machine; refer to Setting the Parking Brake, page 19. Remember to remove the key from the ignition switch.

### **CAUTION**

#### **POTENTIAL HAZARD**

- Someone could move or attempt to operate the tractor while it is unattended.

#### **WHAT CAN HAPPEN**

- Children or bystanders may be injured if they use the tractor.

#### **HOW TO AVOID THE HAZARD**

- Always remove the ignition key and set the parking brake when leaving the machine, even if just for a few minutes.

## Positioning the Seat

The seat can move forward and backward. Position the seat where you have the best control of the machine and are most comfortable.

1. To adjust, remove the locknut and washer, and tip seat forward (Fig. 16).

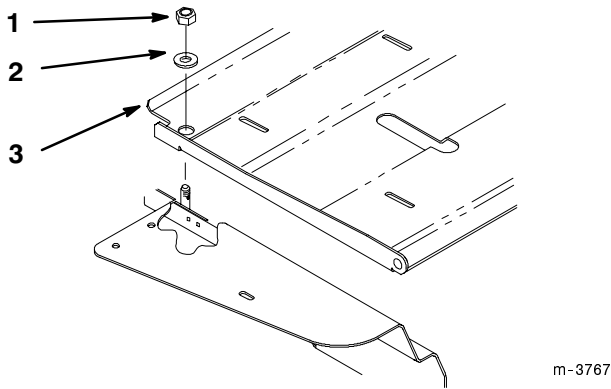

Figure 16

1. Locknut
2. Washer
3. Seat base

2. Loosen the seat mounting bolts slide seat to the desired position in the adjusting slots and tighten the mounting bolts (Fig. 17).

3. Lower seat and secure with washer and locknut (Fig. 16).

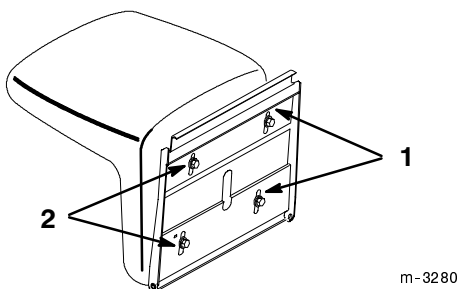

Figure 17

1. Adjustment slot
2. Mounting bolt

## Adjusting Height-of-Cut

The height-of-cut can be adjusted from 25 to 115 mm (1" to 4-1/2") in 13 mm (1/2") increments by relocating four hairpin cotter pins in different hole locations.

1. To adjust, remove hairpin cotter from height-of-cut post (Fig. 18).
2. Select hole in height-of-cut post corresponding to the height-of-cut desired. Lift on side of deck to align holes and insert hairpin cotter (Fig. 18).

**Note:** All four hairpin cotter pins must be in the same hole location for a level cut.

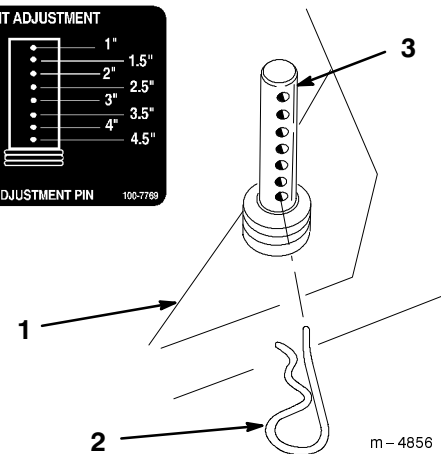
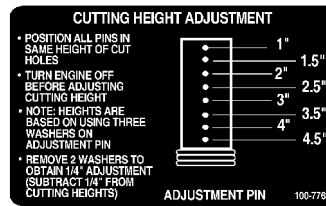

Figure 18

1. Carrier Frame
2. Hairpin Cotter
3. Height-of-Cut Post

## Tilting the Mower

The mower can be tilted up for ease of service or to shorten unit length for transport and storage.

### To Raise Mower

1. Disengage the power take off (PTO), set the parking brake, and turn the ignition key to "OFF" to stop the engine. Remove the key. Remove spark plug wire(s) and remove the key.
2. Lift on side of carrier frame near latch to release weight on latch pin.
3. Pull out on latch pin to release and rotate into notch to hold in the open position (Fig. 19). Repeat on the other side. Lower rear of mower onto rollers.
4. Rotate latch pins into released position after deck has been lowered onto rear rollers.

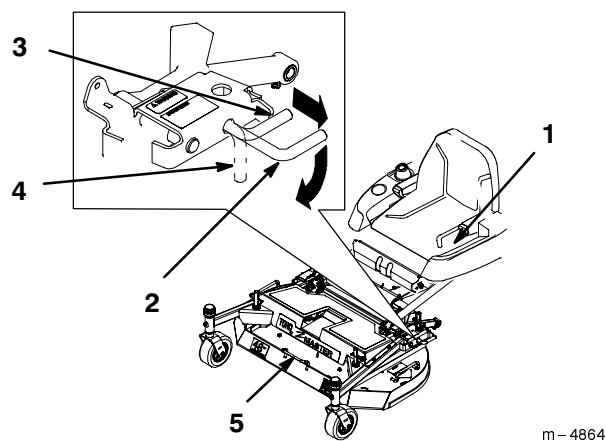

Figure 19

- |                  |                    |
|------------------|--------------------|
| 1. Parking brake | 4. Locked Position |
| 2. Latch pin     | 5. Deck Handle     |
| 3. Notch-open    |                    |

5. Standing in front of the mower, lift up and push rearward on front to raise mower (Fig. 20).
6. Raise mower until it contacts stops and latch pins snap into locked position.

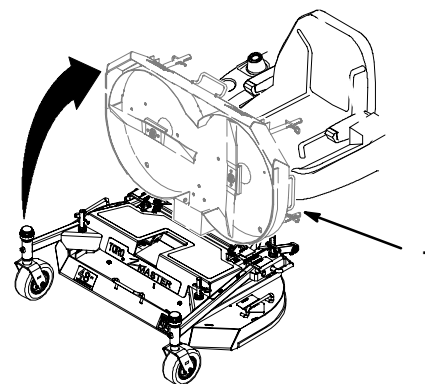

Figure 20

1. Mower up

m-4863

### To Lower Mower

1. Pull out latch pins and rotate into notch to hold in the open position (Fig. 19).
2. Standing in front of the mower, pull front deck handle forward and lower mower (Fig. 20).
3. Rotate latch pins into released position and lift on side of carrier frame near latch pin until latch pin engages (Fig. 19). Repeat on the other side.

## Dumping the Hopper

The hopper is equipped with a “hopper full” sensor that checks for a full condition. When the alarm buzzer sounds the PTO must be moved to the “OFF” position and the hopper needs to be emptied.

**IMPORTANT: The hopper is interlocked with the PTO and the engine will stop if these steps are not followed before dumping the hopper or getting out of the seat.**

1. Locate the traction unit so the hopper door is located where you want to dump the clippings.
2. Ensure that the power take off (PTO) switch is off, move the traction controls to neutral and set the parking brake.
3. Unhook the front latch on hopper (Fig. 21).
4. Lift up on the hopper in the lower front (Fig. 21).
5. Unhook the rear hopper latch and dump the clippings (Fig. 21).

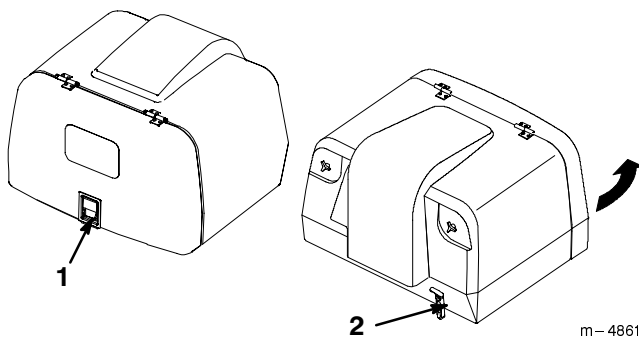

Figure 21

1. Rear Door latch
2. Front Hopper latch
3. Lift here

6. Lower the hopper. Secure the hopper door so it latches and secure the front hopper latch (Fig. 21).

**IMPORTANT: Front left latch must be secured to prevent hopper from accidentally tilting during transport. Ensure the hopper door latch is fully closed.**

## Pushing the Machine by Hand

**IMPORTANT: Always push the machine by hand. Never tow the machine because hydraulic damage may occur.**

### To Push the Machine

1. Disengage the power take off (PTO) and turn the ignition key to “OFF” to stop the engine.
2. Rotate pump by-pass valves counterclockwise 2 turns. This allows hydraulic fluid to by-pass the pump enabling the wheels to turn freely (Fig. 22).

**IMPORTANT: Rotate by-pass valve a maximum of 2 turns so the valve does not come out of the body causing fluid to run out.**

3. Release the parking brake.
4. Push the machine.

### To Operate the Machine

1. Turn the by-pass valves clockwise until they are tight. Do not over tighten (Fig. 22).

**Note:** The machine will not drive unless by-pass valves are turned in completely.

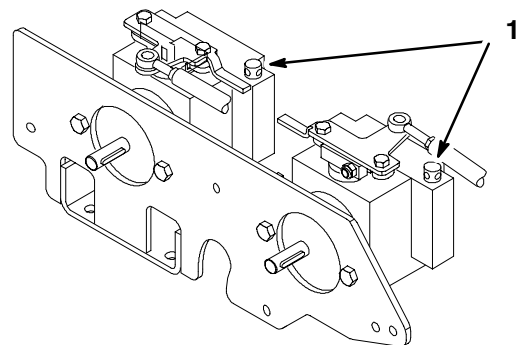
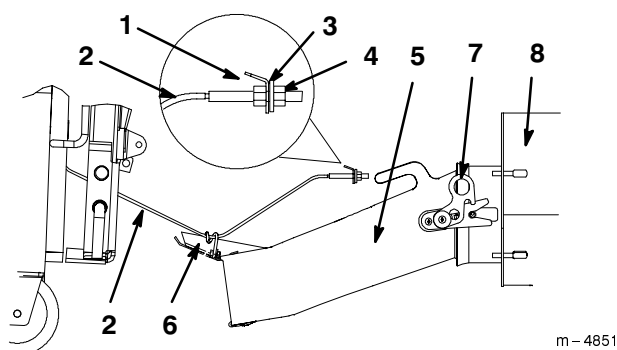

Figure 22

1. By-pass valve

## Removing the Deck and Carrier Frame

1. Disengage the power take off (PTO), set the parking brake, and turn the ignition key to "OFF" to stop the engine. Remove the key.
2. Raise seat to gain access to plenum cable. Remove washer and nut from plenum cable end (Fig. 23).



**Figure 24**

- |                 |                       |
|-----------------|-----------------------|
| 1. Bracket      | 5. Plenum             |
| 2. Plenum Cable | 6. Plenum cable guide |
| 3. Washer       | 7. Plenum Latches     |
| 4. Nut          | 8. Blower Housing     |

3. Remove plenum and plenum cable from traction unit. Refer to Plenum Removal on page 34.
4. Lifting slightly on the deck handles, remove hairpin cotters from the height-of-cut posts and separate mower from carrier frame (Fig. 25).

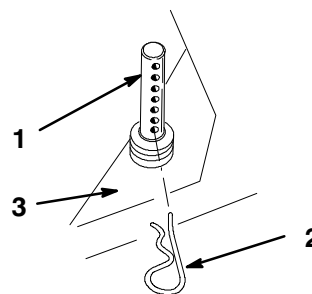

m-4856

**Figure 25**

- |                        |                  |
|------------------------|------------------|
| 1. Height -of-cut post | 3. Carrier Frame |
| 2. Hairpin Cotter      |                  |

5. Tilt carrier frame into its upright position. Refer to Tilting the Mower on page 25.
6. Place a block, approximately 4 inches high, under the carrier frame. This will raise the frame vertically.
7. Check to see if tension has been removed from the spring assemblies. If tension remains add blocks to raise carrier frame higher. If there is too much tension use a smaller block.
8. Remove 3/8" x 23 mm (7/8") shoulder bolts and 3/8" locknuts securing spring end plate assemblies to carrier frame (Fig. 26).

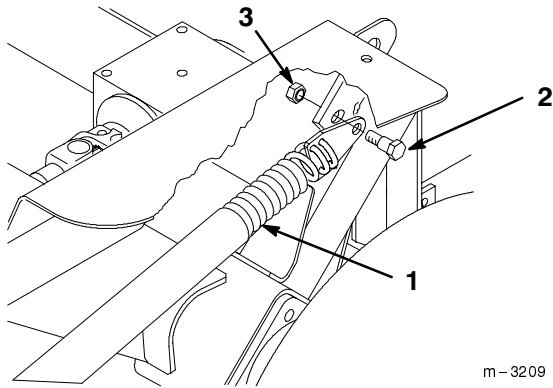

**Figure 26**

- |   |                 |
|---|-----------------|
| 1. Spring Assembly                      | 3. Locknut 3/8" |
| 2. Shoulder Bolt 3/8" x 7/8"<br>(22 mm) |                 |

9. Remove the block under the carrier frame.

10. Unfold carrier frame.

11. Remove the two nuts and bolts that hold the bar for rubber guard. The bar is under the motion control levers. Fold the rubber guard onto the footrest (Fig. 27).

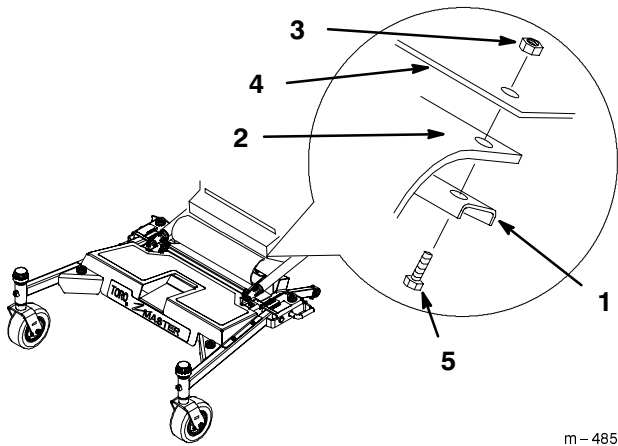
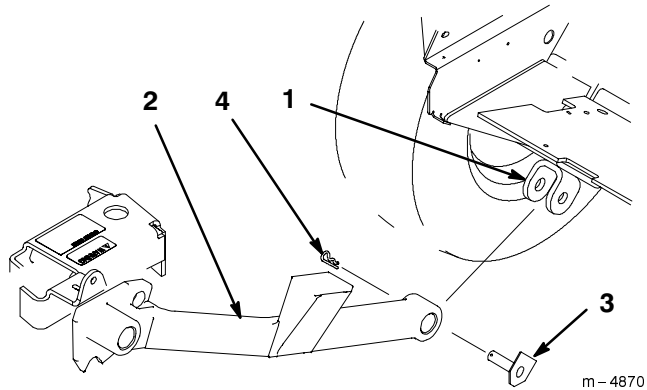

**Figure 27**

- |                 |                  |
|-----------------|------------------|
| 1. Bar          | 4. Machine Panel |
| 2. Rubber Guard | 5. Capscrew      |
| 3. Nut          |                  |

12. Remove hairpin cotters and pivot pin assemblies from push arms at traction unit pivot brackets (Fig. 28).

**Note:** Save all hardware for use when installing mower. Items 3 and 4 are part of traction unit.

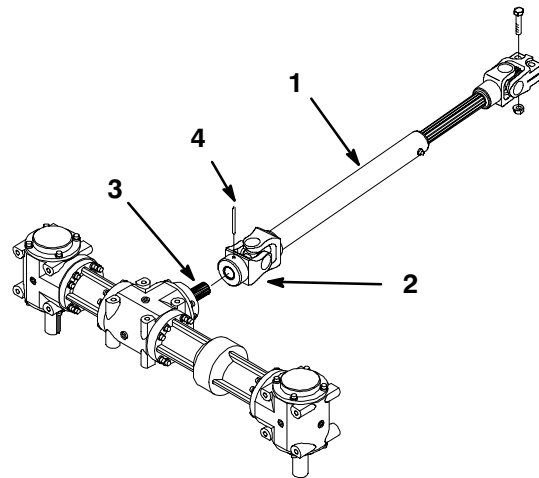

**Figure 28**

- |                  |                            |
|------------------|----------------------------|
| 1. Pivot Bracket | 3. Pivot Pin Assembly-flat |
| 2. Push Arm      | 4. Hairpin Cotter          |

**Note:** Drive shaft remains with traction unit.

13. Drive roll pin through hole in PTO drive shaft to separate from gearbox shaft (Fig. 29).



**Figure 29**

- |                    |                  |
|--------------------|------------------|
| 1. PTO Driveshaft  | 3. Gearbox shaft |
| 2. Universal Joint | 4. Roll Pin      |

14. Move deck and carrier frame away from traction unit.

**Note:** Remove drive shaft from gearbox shaft if you do not hook up a deck immediately or when putting on optional attachments.

15. Remove (2) 3/8"-16 x 41.5 mm (1-5/8") bolts and 3/8"-16 locknuts from universal joint and slide the driveshaft off gearbox shaft (Fig. 30).

**Note:** Save all hardware for use when installing mower.

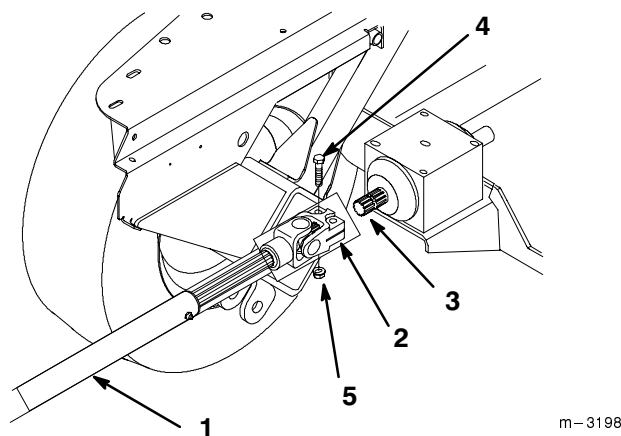

**Figure 30**

- |                    |                                    |
|--------------------|------------------------------------|
| 1. PTO Driveshaft  | 4. Bolt 3/8"-16 x 1-5/8" (41.5 MM) |
| 2. Universal Joint | 5. Locknut 3/8"-16                 |
| 3. Gearbox shaft   |                                    |

## Installing Deck and Carrier Frame

**Note:** Install drive shaft to gearbox shaft if it is not hooked up. Proceed to step 2 if the driveshaft is hooked up.

1. Install (2) 3/8"-16 x 41.5 mm (1-5/8") bolts and 3/8"-16 locknuts from universal joint and slide the driveshaft off gearbox shaft (Fig. 31).

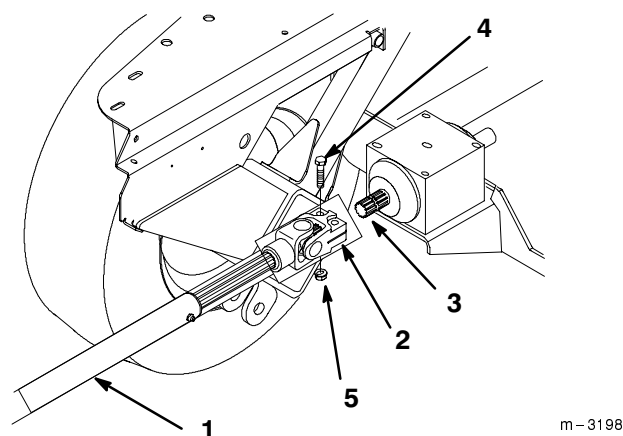
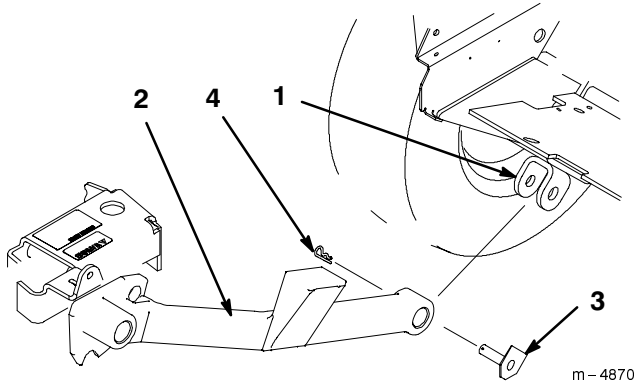

**Figure 31**

- |                    |                                    |
|--------------------|------------------------------------|
| 1. PTO Driveshaft  | 4. Bolt 3/8"-16 x 1-5/8" (41.5 MM) |
| 2. Universal Joint | 5. Locknut 3/8"-16                 |
| 3. Gearbox shaft   |                                    |

2. Position carrier frame in front of traction unit and place push arms into clevises (Fig. 32).
3. Install push arms with pivot pin assemblies, aligned with flat against frame, and secure with hairpin cotters (Fig. 32).

**Note:** Pivot pin assemblies and hairpin cotters are part of traction unit.



**Figure 32**

- |             |                            |
|-------------|----------------------------|
| 1. Clevis   | 3. Pivot Pin Assembly-flat |
| 2. Push Arm | 4. Hairpin Cotter          |

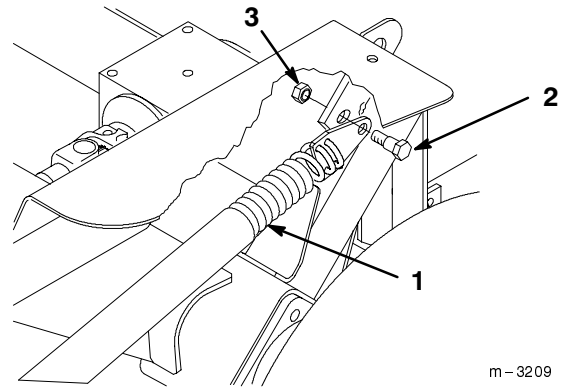
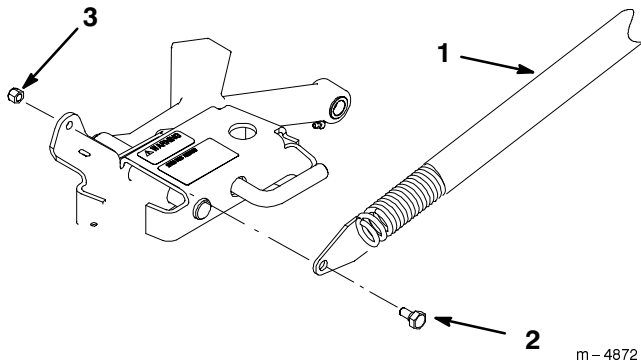

**Figure 34**

- |   |                 |
|---|-----------------|
| 1. Spring Assembly                      | 3. Locknut 3/8" |
| 2. Shoulder Bolt 3/8" x 7/8"<br>(22 mm) |                 |

4. Tilt carrier frame into its upright position. Refer to Tilting the Mower on page 25.
5. Place a block, approximately 101.6mm (4") high, under the carrier frame. This will raise the frame vertically.
6. Secure spring end plate assembly to carrier frame with 3/8" x 23 mm (7/8") shoulder bolt and 3/8" locknut (Fig. 33).

8. Position mower in front of traction unit.
9. Rotate PTO drive shaft so holes align with hole in gearbox shaft and slide together (Fig. 35).
10. Drive roll pin through hole to secure PTO drive shaft to gearbox shaft (Fig. 35).



**Figure 33**

- |   |                 |
|---|-----------------|
| 1. Spring Assembly                      | 3. Locknut 3/8" |
| 2. Shoulder Bolt 3/8" x 7/8"<br>(22 mm) |                 |

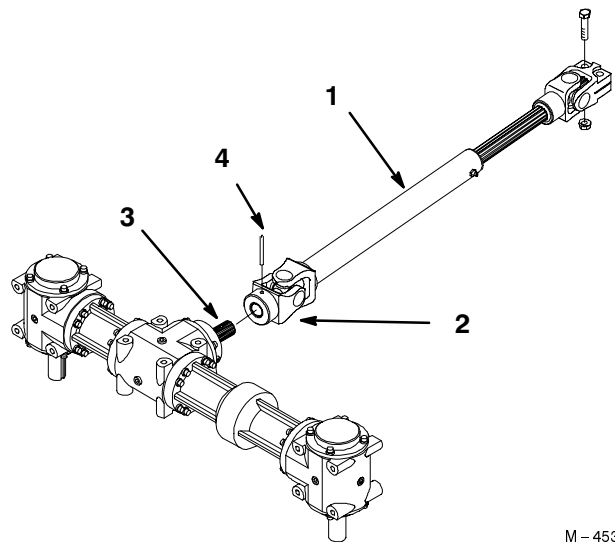

**Figure 35**

- |                    |                  |
|--------------------|------------------|
| 1. PTO Driveshaft  | 3. Gearbox shaft |
| 2. Universal Joint | 4. Roll Pin      |

**Note:** You may have to install spring to traction unit if it is not installed.

7. Install 3/8" x 23 mm (7/8") shoulder bolts and 3/8" locknuts securing spring end plate assemblies to traction unit (Fig. 34).

11. Remove the 101.6mm (4") block. Release the latch levers and push carrier frame down. Latch pins should lock.
12. Select hole in height-of-cut post corresponding to the height-of-cut desired. Lift on side and front to align holes and hairpin cotter (Fig. 36).

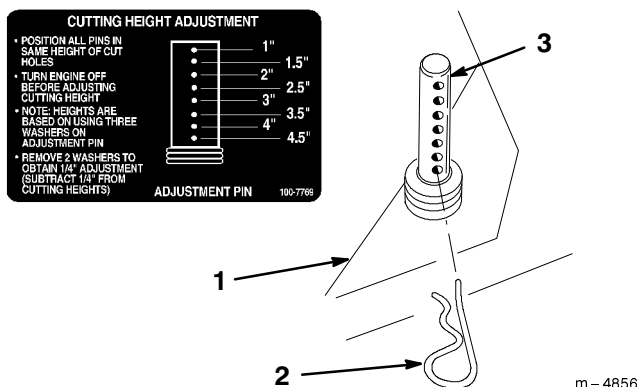

Figure 36

1. Carrier Frame
2. Hairpin Cotter
3. Height-of-Cut Post

**Note:** All four hairpin cotters should be in the same hole location for a level cut.

13. Tilt carrier frame into its upright position. Refer to Tilting the Mower on page 25.
14. Route plenum cable under seat. Raise seat, to gain access to plenum cable. Install cable into bracket and install washer and nut (Fig. 37).

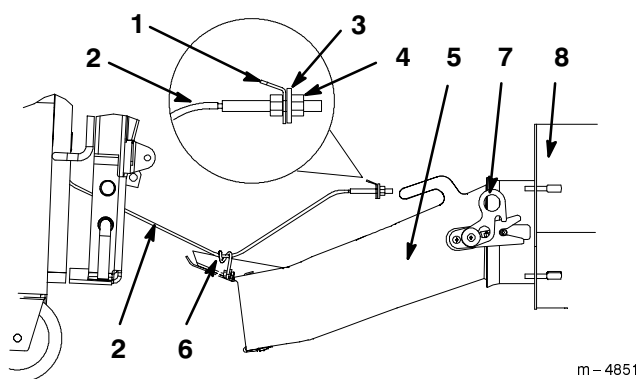

Figure 37

1. Bracket
2. Plenum Cable
3. Washer
4. Nut
5. Plenum
6. Plenum cable guide
7. Plenum Latches
8. Blower Housing

15. Install plenum and plenum cable to traction unit. Refer to Plenum Installation on page 34.

16. Install the rubber guard with bar, nuts and bolts under the motion control levers. (Fig. 38).

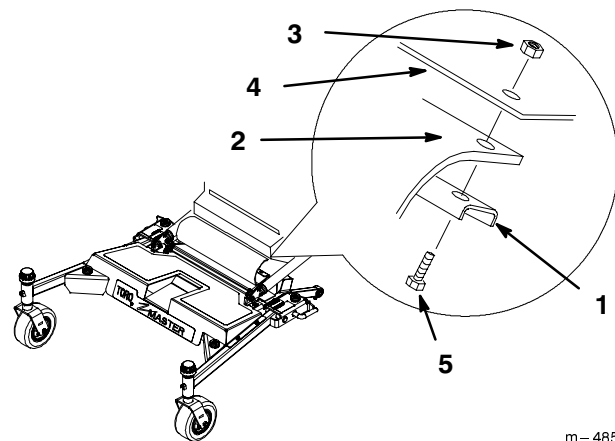

Figure 38

1. Bar
2. Rubber Guard
3. Nut
4. Machine Panel
5. Capscrew

## Install Mulching Baffle

Hardware to install mulching baffle is installed in deck.

1. Tilt mower into the vertical position, refer to; Tilting the Mower, page 25.
2. Remove cap screws, left and right bagger baffles locknuts, carriage bolts, and left and right discharge baffles from the mower (Fig. 41).

**Note:** Reinstall all hardware into deck for use when reinstalling bagging baffles.

3. Remove screws that are installed into deck for securing mulching baffle (Fig. 39).
4. Install baffle using hardware that was removed. (Fig. 39).

**IMPORTANT: All four bagging baffles must be removed when mulching.**

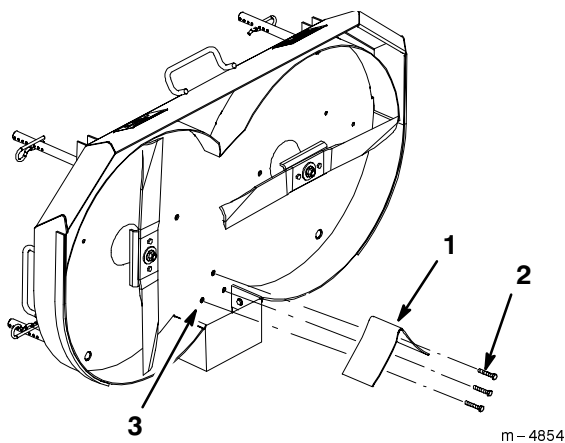

**Figure 39**

1. Mulching baffle
2. Cap Screw
3. Retainer Nut (On top side of deck)

## Mulching Operation

When operating the mower with the mulching baffle installed, you must disengage the blower drive belt.

1. Stop the engine, remove the key and disconnect the spark plug wire(s) from the spark plug(s).
2. Remove hairpin cotter and clevis pin from idler arm (Fig. 40).
3. Push up on the spring loaded idler arm, behind blower on lefthand side of unit, to relax pressure on blower belt (Fig. 40).
4. Align hole in idler arm with slot in frame and insert clevis pin. Secure with hairpin cotter to hold in position.

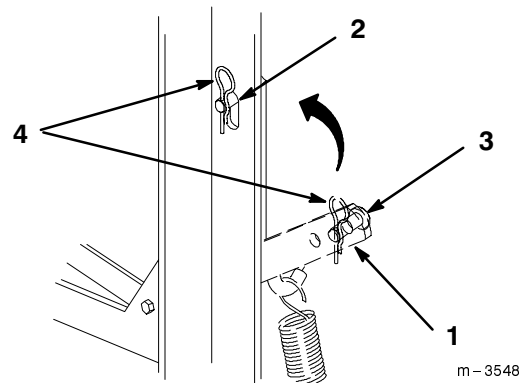

**Figure 40**

1. Idler arm
2. Frame slot
3. Clevis pin
4. Hairpin cotter

5. When operating in mulching mode, the plenum can be removed to prevent damage to it. Refer to Plenum Removal and Installation on page 34.

## Install Bagger and Discharge Baffles

When changing from mulching to bagging, baffles must be removed and replaced

1. Tilt mower into the vertical position, refer to; Tilting the Mower, page 25.
2. Remove capscrews and mulching baffle from the mower (Fig. 39).

**Note:** Reinstall cap screws into deck for use when installing mulching baffle.

3. Position the left and right front bagger baffles inside the mower and secure with capscrews into the retainer nuts (Fig. 41).
4. Position the left and right rear discharge baffles inside the mower. Secure with cap screws through the bottom and carriage bolts inside of mower rear discharge. Secure carriage bolts with locknuts (Fig. 41).

**IMPORTANT: All four bagging baffles must be in place when bagging.**

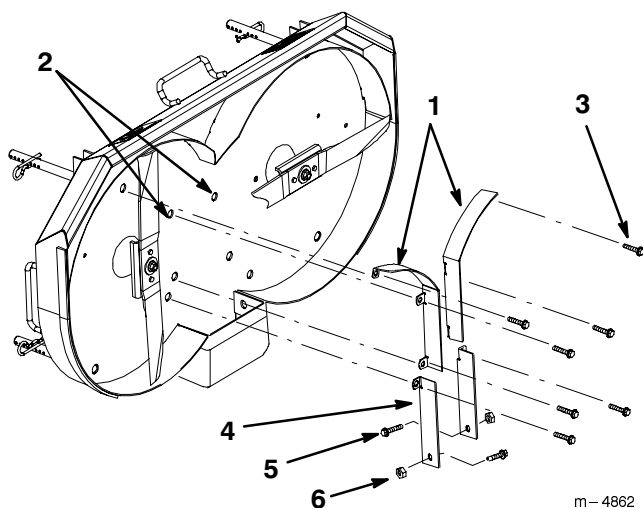

Figure 41

- |                  |                     |
|------------------|---------------------|
| 1. Bagger baffle | 4. Discharge baffle |
| 2. Retainer Nut  | 5. Carriage Bolt    |
| 3. Cap Screw     | 6. Lock Nut         |

## Bagger Operation

When operating the mower with bagger baffles installed you must engage the blower drive belt.

1. Stop the engine, remove the key and disconnect the spark plug wire(s) from the spark plug(s).
2. Ensure belt is around blower, idler and PTO pulleys.
3. Push up on the spring loaded idler arm, behind blower on lefthand side of unit, to relax pressure on clevis pin (Fig. 42).
4. Remove hairpin cotter and clevis pin from slot in frame and allow idler down, to tension belt (Fig. 42).
5. Install hairpin cotter and clevis pin in outer hole of idler arm for storage (Fig. 42).

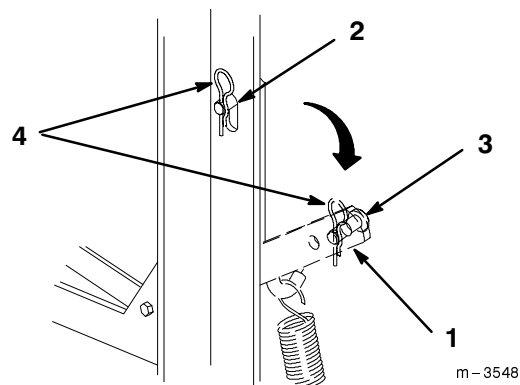

Figure 42

- |               |                   |
|---------------|-------------------|
| 1. Idler arm  | 3. Clevis pin     |
| 2. Frame slot | 4. Hairpin cotter |

## Plenum Removal and Installation

To avoid damage to the plenum, remove the plenum when not in bagging mode.

### CAUTION

#### POTENTIAL HAZARD

- An injury may occur when removing bagging components.

#### WHAT CAN HAPPEN

- A person can cut hands or fingers.

#### HOW TO AVOID THE HAZARD

- Keep hands and fingers out of blower housing.
- Do not operate in bagging mode without entire bagging system in place.
- Stop engine before cleaning bagging system.

### Plenum Removal

1. Tilt deck to upright position. Refer to Tilting the Mower on page 25.
2. Reach through from lefthand side in front of traction tire, lift plenum and unwind cable clockwise around plenum cable guide.
3. Flip seat up and unlatch plenum from both sides of blower inlet (Fig. 43).
4. Pull plenum out from blower housing and place it on the ground (Fig. 43).
5. Pull or slide plenum out from between deck and traction tire (Fig. 43).

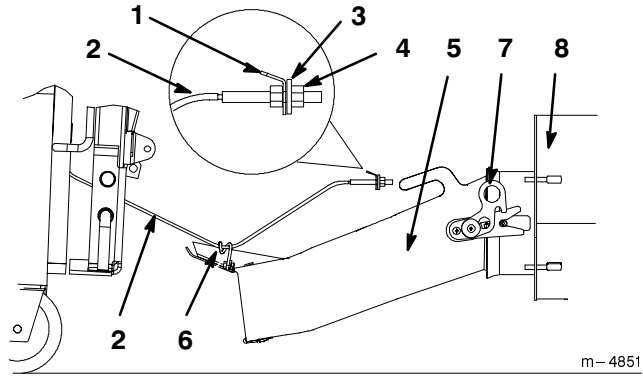

Figure 43

- |                 |                       |
|-----------------|-----------------------|
| 1. Bracket      | 5. Plenum             |
| 2. Plenum Cable | 6. Plenum cable guide |
| 3. Washer       | 7. Plenum Latches     |
| 4. Nut          | 8. Blower Housing     |

### Plenum Installation

1. Tilt deck to upright position. Refer to Tilting the Mower on page 25.
2. Slide plenum, with blower end in first, between deck and traction tire.
3. Flip seat up, reach down and direct plenum into blower housing. Ensure the plenum latches lock into both sides of blower housing (Fig. 43).
4. Reach through from lefthand side in front of traction tire, lift plenum and wind cable counter clockwise around plenum cable guide (Fig. 43).

# Maintenance

## Service Interval Chart

Service Operation	Each Use	8 Hours	25 Hours	50 Hours	100 Hours	200 Hours	Storage Service
Hydraulic fluid—check level	Initial	X					X
Oil—check level	X						X
Oil—change*		Initial			X		X
Oil Filter—change (200 hours or every other oil change)						X	X
Hydraulic filter—change		Initial				X	X
Safety System—check	X						X
Hopper - clean	X		X				X
Screens - clean (as required)							X
Mower Housing - clean	X	X					X
Cutting Blades - check		X					X
Chassis—grease*		X					X
Drive Shaft—grease*		X					X
Push arm bushings - grease		X					X
Castor Wheels - grease			X				X
Mower Gearbox - check					X		X
Mower Gearbox- change					Initial		
Foam Air Cleaner—service*			X				X
Paper Air Cleaner—replace*					X		X
Spark Plug(s)—check						X	X
Belts—check for wear/cracks				X			X
Gasoline—drain							X
Cooling systems-clean	X				X		X
Hydraulic lines-check					X		X
Battery-check electrolyte		X					X
Battery-charge, Disconnect cables							X
Fuel Filter—replace						X	X
Tires—check pressure				X			X
Chipped Surfaces—paint							X
* More often in dusty, dirty conditions							

**⚠ CAUTION**

**POTENTIAL HAZARD**

- If you leave the key in the ignition switch, someone could start the engine.

**WHAT CAN HAPPEN**

- Accidental starting of the engine could seriously injure you or other bystanders.

**HOW TO AVOID THE HAZARD**

- Remove the key from the ignition switch and pull the wire(s) off the spark plug(s) before you do any maintenance. Also push the wire(s) aside so it does not accidentally contact the spark plug(s).

## Cutting Blades

To ensure a superior quality of cut, keep the blades sharp. For convenient sharpening and replacement, you may want to keep extra blades on hand.

**⚠ WARNING**

**POTENTIAL HAZARD**

- A blade that is worn or damaged could break apart and pieces could be thrown at bystanders or at you as you use the mower.

**WHAT CAN HAPPEN**

- Pieces of blade that may be thrown could seriously injure or kill you or bystanders.

**HOW TO AVOID THE HAZARD**

- Periodically inspect the blade for wear and damage. Immediately install a new blade if it is worn or damaged.

## Before Inspecting or Servicing the Blades

Park the machine on a level surface, disengage the blade control (PTO) and set the parking brake. Turn the ignition key to “OFF” to stop the engine. Remove the key and disconnect the spark plug wire(s) from the spark plug(s).

## Inspecting the Blades

1. Inspect the cutting edges (Fig 44). If the edges are not sharp or have nicks, remove and sharpen the blades. Refer to Sharpening the Blades on page 38.
2. Inspect the blades, especially the curved area (Fig. 44). If you notice any damage, wear, or a slot forming in this area (item 3 in Fig. 44), immediately install a new blade.

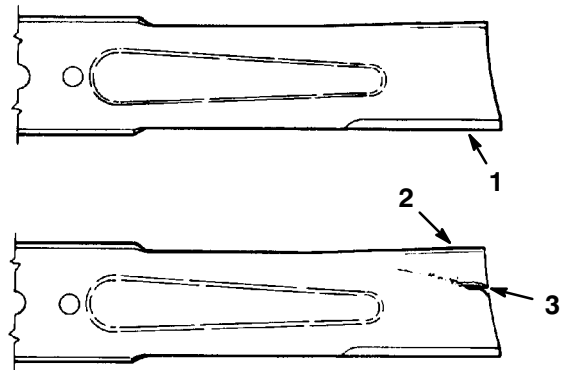

**Figure 44**

1. Cutting Edge
2. Curved Area
3. Wear/slot Forming

m-151

## Checking for Bent Blades

1. Rotate the blades until the ends face forward and backward (Fig. 45). Measure from a level surface to the cutting edge tip of the blades (Fig. 45). Note this dimension.
2. Rotate the opposite ends of the blades forward. Measure from a level surface to the cutting edge tip of the blades at the same position as in step 1 above. The difference between the dimensions obtained in steps 1 and 2 must not exceed 3 mm (1/8"). If this dimension exceeds 3 mm (1/8"), the blade is bent and must be replaced. Refer to Removing the Blades, and Installing the Blades on page 37.

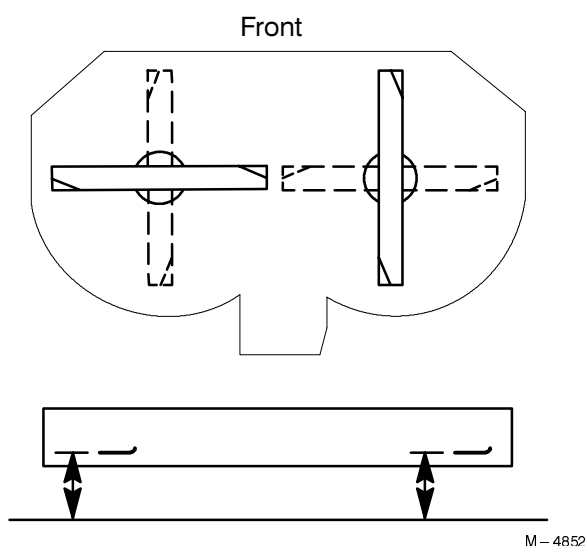

Figure 45

## WARNING

### POTENTIAL HAZARD

- A blade that is bent or damaged could break apart and pieces could be thrown at bystanders or at you as you use the mower.

### WHAT CAN HAPPEN

- Pieces of blade that may be thrown could seriously injure or kill you or bystanders.

### HOW TO AVOID THE HAZARD

- Always replace bent or damaged blade with a new blade.
- Never file or create sharp notches in the edges or surfaces of blade.

## Removing the Blades

Blades must be replaced if a solid object is hit, if the blade is out of balance or is bent. To ensure optimum performance and continued safety conformance of the machine, use genuine TORO replacement blades. Replacement blades made by other manufacturers may result in non-conformance with safety standards.

Hold the blade end using a rag or thickly-padded glove. Remove the retainer bolt with its washer and spacer, and the blade bolts and locknuts from the blade retainer (Fig. 47).

## Installing the Blades

**IMPORTANT:** The blades are different for each side and rotate in opposite directions forcing clippings to the center rear of the mower. Align cutting edges properly when installing. Sails of blades must point towards the top of the deck.

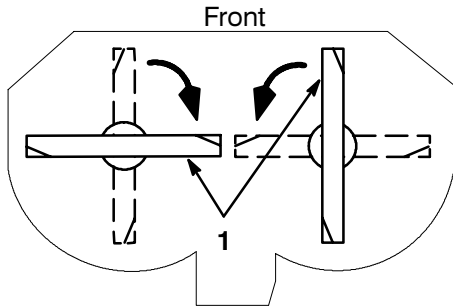

M-4852

Figure 46

1. Cutting edge

1. Position the blade onto the blade retainer and secure with shear bolts and locknuts (Fig. 47).

**IMPORTANT: The curved part of the blade, the sail, must be pointing upward toward the top of the mower to ensure proper cutting.**

2. Torque blade shear bolts to 10.2 N•m (90 in-lb).

**Note:** Use anti-seize lubricant on spindle before installing blade retainer.

3. Install the key in the retainer. Install the blade, spacer, washer, and retainer bolt to spindle (Fig. 47).

4. Torque the retainer bolt to 115-140 N•m (85-110 ft-lb).

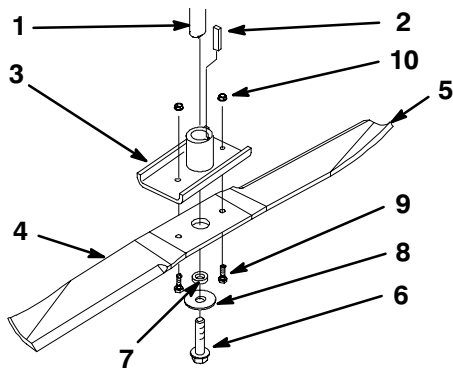

M-4458

Figure 47

- |                       |                  |
|-----------------------|------------------|
| 1. Spindle            | 6. Retainer bolt |
| 2. Key                | 7. Spacer        |
| 3. Blade retainer     | 8. Washer        |
| 4. Blade              | 9. Shear Bolt    |
| 5. Sail Area of Blade | 10. Locknut      |

## Sharpening the Blades

1. Use a file to sharpen the cutting edge at both ends of the blade (Fig. 48). Maintain the original angle. The blade retains its balance if the same amount of material is removed from both cutting edges.

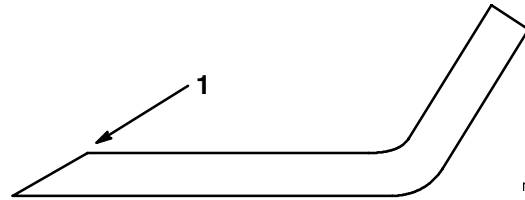

m-1854

Figure 48

1. Sharpen at original angle

2. Check the balance of the blade by putting it on a blade balancer (Fig. 49). If the blade stays in a horizontal position, the blade is balanced and can be used. If the blade is not balanced, file some metal off the end of the sail area only (Fig. 49). Repeat this procedure until the blade is balanced.

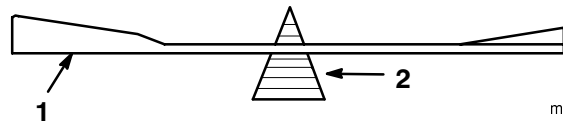

m-1855

Figure 49

1. Blade
2. Balancer

## Correcting Cutting Unit Mismatch

If one cutter blade cuts lower than the other, correct as follows:

1. Stop the engine, remove the key and disconnect the spark plug wire(s) from the spark plug(s).
2. Adjust the tire pressure in all tires to specifications and check that the blades are not bent. Refer to Checking for Bent Blades on page 37.
3. Set the height-of-cut to the 63.5mm (2-1/2") position. Refer to Adjusting the Height-Of-Cut in the Operation section. Make sure there is no excessive wear on push arm pivot points.
4. Refer to Matching Height-of-Cut, Checking Front to Rear Pitch and Checking Side to Side Leveling on pages 39, 40 and 41.

## Matching Height of Cut

The height of cut needs to be checked and correct before the front to rear pitch and side to side leveling is performed.

1. Check the tire pressure on both deck and traction unit.
2. Set the height-of-cut to the 63.5mm (2-1/2") position following the height-of-cut decal.
3. With the machine on level surface, position one blade front-to-rear (Fig. 50). Measure at "A" and from level surface to the cutting edge of the blade tips (Fig. 51).
4. The measurement should be 63.5mm (2-1/2"). Rotate blades and repeat for opposite blade.

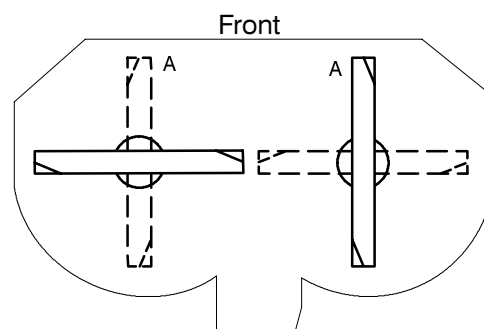

M - 4852

Figure 50

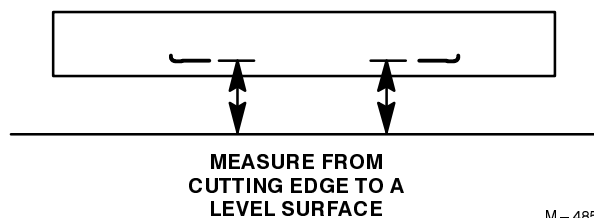

M - 4852

Figure 51

5. If it does not measure correctly remove or add washers to the height-of-cut posts. Match the hole in the post with the decal and the measured height-of-cut (Fig. 53).

**Note:** Make sure you add or remove washers from all four height-of-cut posts.

## Checking the Front-to-Rear Pitch

The height of cut needs to be checked and correct before the front to rear pitch leveling is performed.

1. Check the tire pressure on both deck and traction unit.
2. Position one blade front-to-rear (Fig. 52). Measure at "C" and "D" locations (Fig. 52) from a level surface to the cutting edge of the blade tips (Fig. 53).
3. **The mower blade should be 6-9.5 mm (1/4"-3/8") lower in front "C" than in the rear "D".** Rotate blades and repeat for opposite blade. If it is not correct proceed to Change the Front-to-Rear Pitch.

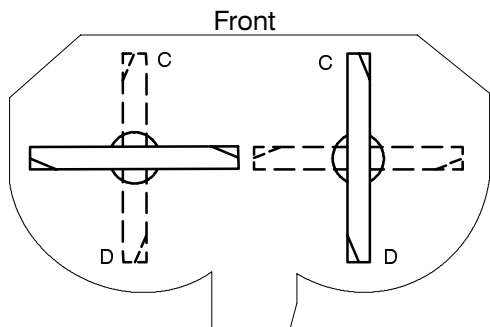

M-4852

Figure 52

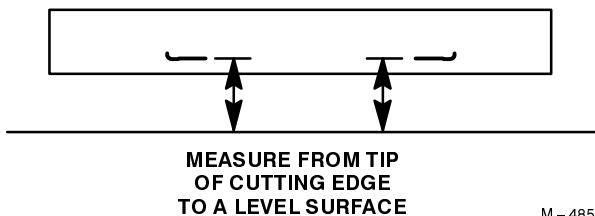

M-4852

Figure 53

## Change the Front-to-Rear Pitch

Changing the front-to-rear pitch is done by removing or adding washers to height of cut posts.

1. Check the tire pressure on both deck and traction unit.
2. To change the front-to-rear pitch, remove the hairpin cotter and move an equal number of washers on front or rear height-of-cut posts.
3. Add washers to the height-of-cut posts to raise the mower.
4. Remove washers from the height-of-cut posts to lower the mower.
5. Check the Front-to-Rear Pitch.

## Checking the Side-to-Side Leveling

The height of cut needs to be checked and correct before the side to side leveling is performed.

1. Check the tire pressure on both deck and traction unit.
2. Position the blades side-to-side (Fig.54 ). Measure at “A” and “B” locations (Fig. 54) from a level surface to the cutting edge of blade tips (Fig.55).
3. The difference between measurements “A” and “B” should be no more than 6 mm (1/4”).

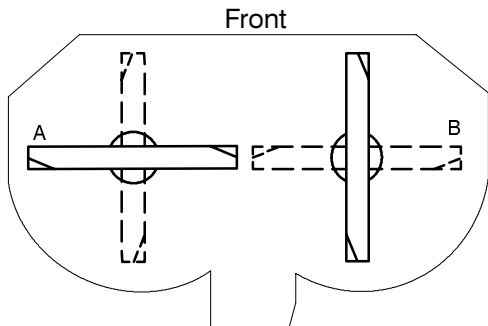

M-4852

Figure 54

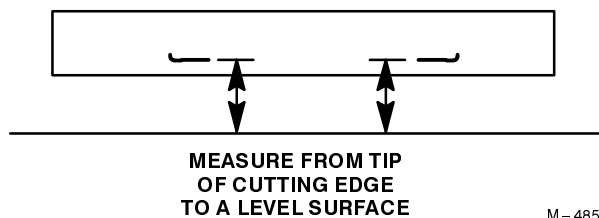

M-4852

Figure 55

## Change the Side-to-Side Leveling

Changing the side-to-side leveling is done by removing or adding washers to height of cut posts. Do this to the corresponding side that needs adjustment.

1. Check the tire pressure on both deck and traction unit.
2. To change the side-to-side leveling, remove the hairpin cotter and remove or add washers on one side only.
3. Add washers to the height-of-cut posts to raise the corresponding side of the mower.
4. Remove washers from the height-of-cut posts to lower the corresponding side of the mower.
5. Recheck the front-to-rear pitch and side to side leveling of the cutting unit.

## Air Cleaner

Primary Filter: Clean or replace every 200 operating hours or when Filter Minder reaches “Change Filter” level.

Safety Filter: Replace after every 600 operating hours.

**Note:** Service the air cleaner more frequently if operating conditions are extremely dusty or sandy.

### Using Filter Minder

This machine contains an air cleaner “Filter Minder” gauge.

Filter Minder: Check this daily.

The plunger inside the gauge canister will rise as the air cleaner becomes dirty and restricted from use. As it approaches or reaches the “Change Filter” level, air cleaner maintenance is required.

1. Start by visually checking the condition of the primary element. If the element is visually dirty, replace the primary element. **Do not attempt to clean it.**
2. Reset the gauge by depressing the button in the bottom of the canister until the plunger returns to the lowest point.
3. Test run the engine and recheck the gauge. If the plunger remains in the lower ranges, normal operation can resume. If the plunger returns to the “Change Filter” level, the primary element is restricted and must be replaced, even though it may not appear to be dirty.
4. The gauge may be reset at any time, however it will return to the prior position if corrective filter servicing has not been performed.

### Removing the Filter

1. Disengage the power take off (PTO), set the parking brake, and turn the ignition key to “OFF” to stop the engine. Remove the key.
2. Remove the wing nut from the bolt in the air filter guard. Rotate guard to gain access to filter (Fig. 56).

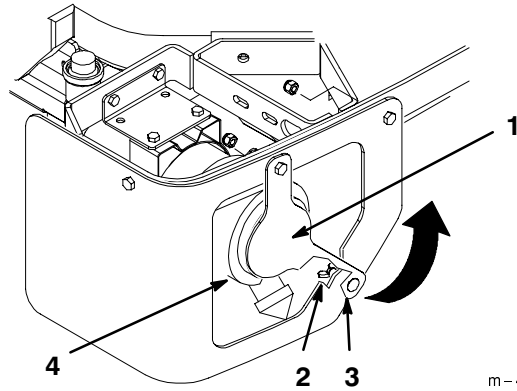

Figure 56

m-4845

- |                 |           |
|-----------------|-----------|
| 1. Filter guard | 3. Bolt   |
| 2. Wing nut     | 4. Filter |

3. Release the latches on the air cleaner and pull the air cleaner cover off of the air cleaner body (Fig. 57).
4. Clean the inside of the air cleaner cover with compressed air.
5. Gently slide the primary filter out of the air cleaner body (Fig. 57). Avoid knocking the filter into the side of the body. Do not remove the safety filter, unless you intend to replace it as well.
6. Inspect the primary filter for damage by looking into the filter while shining a bright light on the outside of the filter. Holes in the filter will appear as bright spots. If the filter is damaged, discard it, otherwise clean it.

**IMPORTANT:** Never attempt to clean the safety filter. If the safety filter is dirty, then the primary filter is damaged and you should replace both filters.

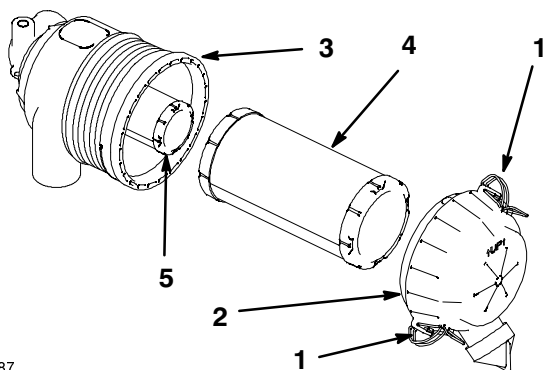

m-4387

Figure 57

- |                      |                   |
|----------------------|-------------------|
| 1. Latches           | 4. Primary filter |
| 2. Air cleaner cover | 5. Safety filter  |
| 3. Air filter body   |                   |

## Cleaning the Primary Filter

Blow compressed air from the inside to the outside of the primary filter.

**IMPORTANT:** Do not exceed 689.5kPa (100 psi) and keep the hose at least 2 inches from the filter.

## Installing the Filters

1. If installing new filters, check each filter for shipping damage. Do not use a damaged filter.
2. If the safety filter is being replaced, carefully slide it into the filter body (Fig. 57).
3. Carefully slide the primary filter over the safety filter (Fig. 57). Ensure that it is fully seated by pushing on the outer rim of the filter while installing it.

**IMPORTANT:** Do not press on the soft inside area of the filter.

4. Install the air cleaner cover with the side indicated as UP facing up and secure the latches (Fig. 57).

## Engine Oil

Change oil:

- After the first 5 operating hours.
- After every 100 operating hours.

**Note:** Change oil more frequently when operating conditions are extremely dusty or sandy.

Oil Type: Detergent oil (API service SG or SH)

Crankcase Capacity: w/filter, 2 l (2.1 qt.)

Viscosity: See table below

### USE THESE SAE VISCOSITY OILS

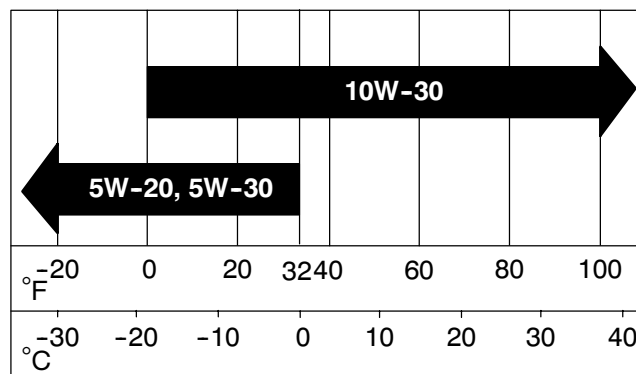

## Checking Oil Level

1. Park the machine on a level surface, disengage the power take off (PTO) and turn the ignition key to “OFF” to stop the engine. Remove the key.
2. Clean around the oil dipstick (Fig. 58) so dirt cannot fall into the filler hole and damage the engine.
3. Pull the oil dipstick and wipe the metal end clean (Fig. 58).
4. Slide the oil dipstick fully into the filler tube (Fig. 58). Pull the dipstick out and look at the metal end. If oil level is low, slowly pour only enough oil into the filler tube to raise the level to the “FULL” mark.

**IMPORTANT: Do not overfill the crankcase with oil because the engine may be damaged.**

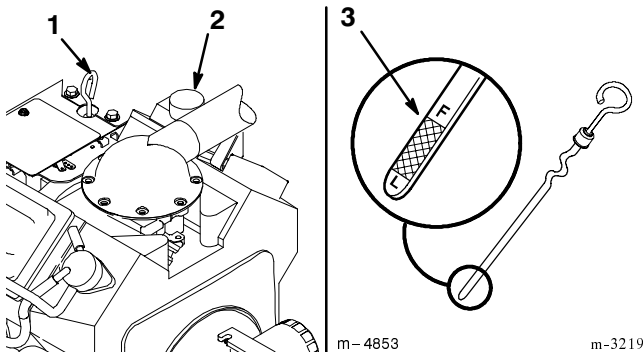

Figure 58

1. Oil dipstick
2. Filler Cap
3. Metal end

## Changing/Draining Oil

1. Start the engine and let it run five minutes. This warms the oil so it drains better.
2. Park the machine so that the drain side is slightly lower than the opposite side to assure the oil drains completely. Then disengage the power take off (PTO), set the parking brake, and turn the ignition key to “OFF” to stop the engine. Remove the key.
3. Place a pan below the oil drain. Remove the oil drain cap (Fig. 59).
4. When oil has drained completely, install the drain cap.

**Note:** Dispose of the used oil at a recycling center.

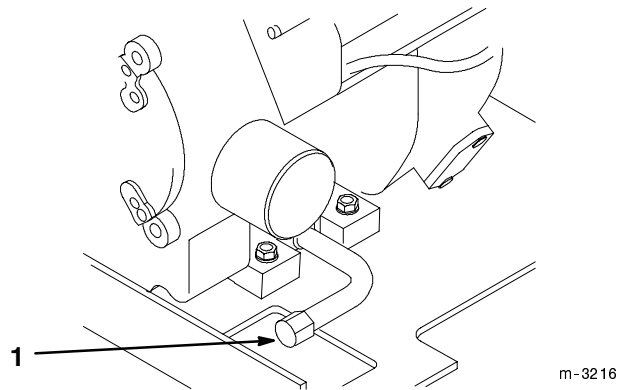

Figure 59

1. Oil drain cap

5. Slowly pour approximately 80% of the specified oil, on page 43, into the fill opening (Fig. 58). Now check the oil level; refer to Checking Oil Level, page 44. Slowly add additional oil to bring to “FULL” mark on dipstick.

## Change Oil Filter

Replace the oil filter every 200 hours or every other oil change.

**Note:** Change oil filter more frequently when operating conditions are extremely dusty or sandy.

1. Drain the oil from the engine; refer to Changing/Draining Oil, page 44.
2. Remove the old filter and wipe the filter adapter (Fig. 60) gasket surface.
3. Pour new oil of the proper type in through the center hole. Stop pouring when the oil reaches the bottom of the threads. Allow a minute or two for the oil to be absorbed by filter material.
4. Apply a thin coat of new oil to the rubber gasket on the replacement filter (Fig. 60).

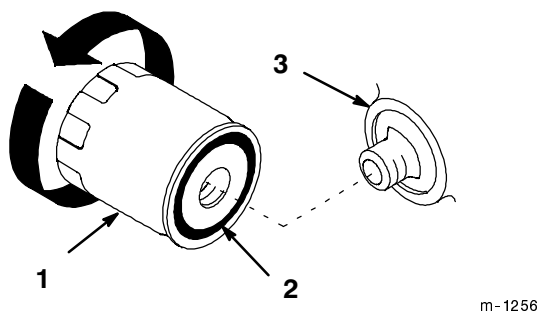

**Figure 60**

- |               |            |
|---------------|------------|
| 1. Oil filter | 3. Adapter |
| 2. Gasket     |            |

5. Install the replacement oil filter to the filter adapter. Turn the oil filter clockwise until the rubber gasket contacts the filter adapter, then tighten the filter an additional 1/2 turn (Fig. 60).
6. Fill the crankcase with the proper type of new oil; refer to Changing/Draining Oil, page 44.

## Spark Plug

Check the spark plug(s) after every 200 operating hours. Make sure the air gap between the center and side electrodes is correct before installing the spark plug. Use a spark plug wrench for removing and installing the spark plug(s) and a gapping tool/feeler gauge to check and adjust the air gap. Install a new spark plug(s) if necessary.

Type: Champion RC12YC (or equivalent)

Air Gap: 0.030 in. (0.76 mm)

### Removing the Spark Plug(s)

1. Disengage the power take off (PTO), set the parking brake, and turn the ignition key to "OFF" to stop the engine. Remove the key.
2. Pull the wire(s) off the spark plug(s) (Fig. 61). Now clean around the spark plug(s) to prevent dirt from falling into the engine and potentially causing damage.
3. Remove the spark plug(s) and metal washer.

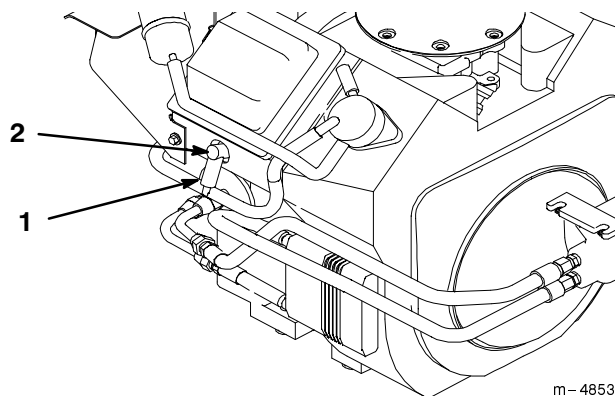

**Figure 61**

- |                    |               |
|--------------------|---------------|
| 1. Spark plug wire | 2. Spark plug |
|--------------------|---------------|

## Checking the Spark Plug

1. Look at the center of the spark plug(s) (Fig. 62). If you see light brown or gray on the insulator, the engine is operating properly. A black coating on the insulator usually means the air cleaner is dirty.

**IMPORTANT: Never clean the spark plug(s). Always replace the spark plug(s) when it has: a black coating, worn electrodes, an oily film, or cracks.**

2. Check the gap between the center and side electrodes (Fig. 62). Bend the side electrode (Fig. 62) if the gap is not correct.

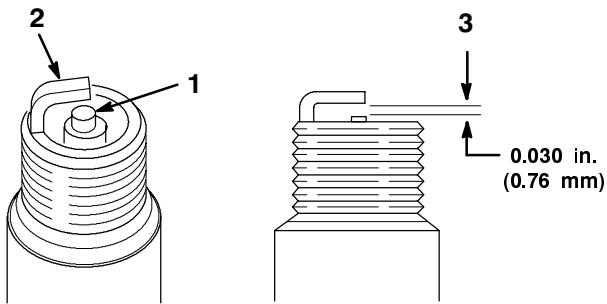

m-3215

**Figure 62**

1. Center electrode insulator
2. Side electrode
3. Air gap (not to scale)

## Installing the Spark Plug(s)

1. Install the spark plug(s). Make sure the air gap is set correctly.
2. Tighten the spark plug(s) to 27 N.m (20 ft-lb).
3. Push the wire(s) onto the spark plug(s) (Fig. 61).

## Fuel Filter

Replace the fuel filter after every 200 operating hours or yearly, whichever occurs first.

### Replacing the Fuel Filter

Never install a dirty filter if it is removed from the fuel line.

1. Disengage the power take off (PTO), set the parking brake, and turn the ignition key to “OFF” to stop the engine. Remove the key.
2. Close fuel shut-off valve at fuel tank (Fig. 64).
3. Squeeze the ends of the hose clamps together and slide them away from the filter (Fig. 63).
4. Remove the filter from the fuel lines.
5. Install a new filter and move the hose clamps close to the filter.
6. Open fuel shut-off valve at fuel tank (Fig. 64).

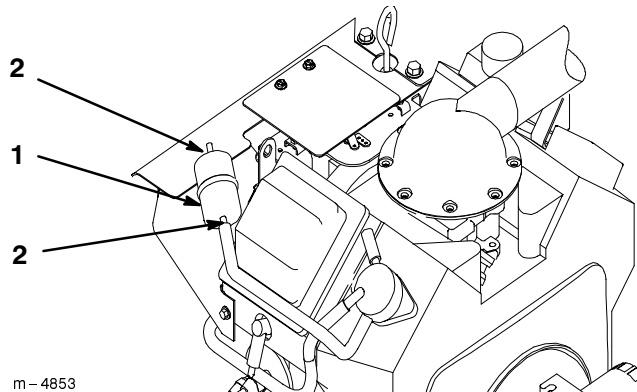

m-4853

**Figure 63**

1. Filter
2. Hose clamp

## Fuel Tank

### Draining The Fuel Tank

#### DANGER

##### POTENTIAL HAZARD

- In certain conditions gasoline is extremely flammable and highly explosive.

##### WHAT CAN HAPPEN

- A fire or explosion from gasoline can burn you, others, and cause property damage.

##### HOW TO AVOID THE HAZARD

- Drain gasoline from the fuel tank when the engine is cold. Do this outdoors in an open area. Wipe up any gasoline that spills.
- Never drain gasoline near an open flame or where gasoline fumes may be ignited by a spark.
- Never smoke near fuel.

1. Park the machine on a level surface, to assure fuel tank drains completely. Then disengage the power take off (PTO), set the parking brake, and turn the ignition key to "OFF" to stop the engine. Remove the key.
2. Close fuel shut-off valve at fuel tank (Fig. 64).
3. Loosen the hose clamp and slide it up the fuel line away from the fuel shut-off valve (Fig. 64).
4. Pull the fuel line off fuel shut-off valve (Fig. 64). Open fuel shut-off valve and allow gasoline to drain into a gas can or drain pan.

**Note:** Now is the best time to install a new fuel filter because the fuel tank is empty.

5. Install the fuel line onto the fuel shut-off valve. Slide the hose clamp close to the fuel shut-off valve to secure the fuel line (Fig. 64).

**IMPORTANT:** Ensure that the fuel line is routed correctly to avoid damage to the fuel line.

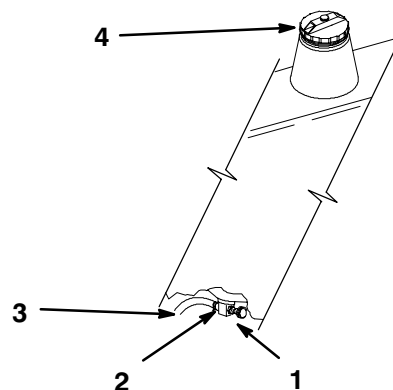

m-3293

**Figure 64**

- |                        |              |
|------------------------|--------------|
| 1. Fuel shut-off valve | 3. Fuel line |
| 2. Hose clamp          | 4. Fuel cap  |

## Cleaning the Cooling Systems

Before each use, check and clean cooling screen. Remove any build-up of grass, dirt or other debris from the oil cooler screen and engine air intake. Every 100 hours clean oil cooler, engine cylinder and cylinder head cooling fins. Also clean around carburetor, governor levers and linkage. This will help insure adequate cooling to hydraulic pumps, motors and engine and will reduce the possibility of overheating and mechanical damage.

1. To remove cooling screen remove lower bolts and loosen top bolts. Slide screen down and rearward to expose oil cooler (Fig. 65). Save all mounting hardware.
2. Blow out fins of oil cooler and area between fins and screen with compressed air. If area between screen and fins is tightly packed, remove oil cooler.
3. Clean off engine air intake (Fig. 65).
4. Install screen from rear and raise over oil cooler. Secure with previously removed hardware (Fig. 65).

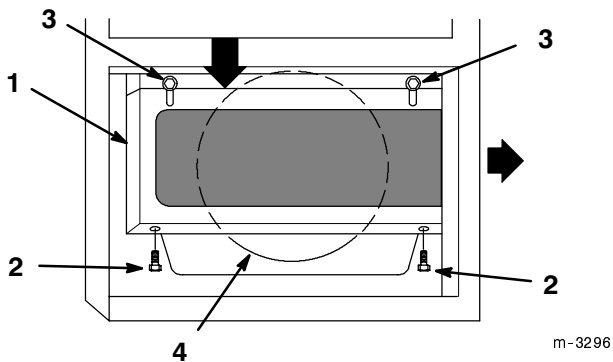

Figure 65

- |                      |                      |
|----------------------|----------------------|
| 1. Oil cooler screen | 3. Top bolts         |
| 2. Lower bolts       | 4. Engine air intake |

## Greasing and Lubrication

The unit must be lubricated regularly. Refer to the Service Interval Chart on page 35.

Grease Type: No. 2 general purpose lithium base or molybdenum base grease.

### How to Grease

1. Disengage the power take off (PTO) and turn the ignition key to "OFF" to stop the engine. Remove the key.
2. Clean the grease fittings with a rag. Make sure to scrape any paint off the front of the fitting(s).
3. Connect a grease gun to the fitting. Pump grease into the fittings until grease begins to ooze out of the bearings.
4. Wipe up any excess grease.

### Where to Add Grease

1. Lubricate the castor wheel bearings and motion control lever pivots until grease begins to ooze out of the bearings (Fig. 66).

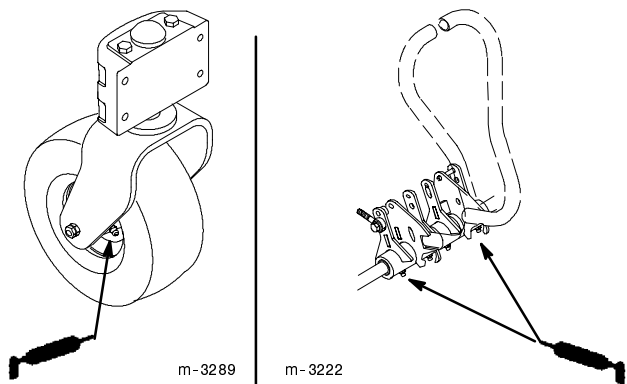
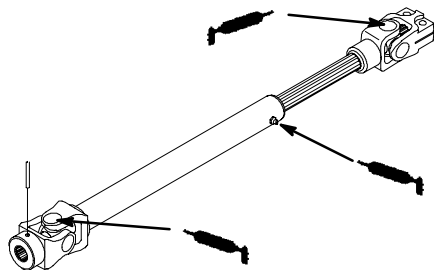

Figure 66

- Grease the fittings on drive shaft and universal joints (Fig. 67).



m-3203

Figure 67

- PTO Driveshaft
- Universal Joint

- Grease the fittings on push arms (Fig. 68).



m-4871

Figure 68

- Push arm grease fitting

- Grease the fittings on the carrier frame castor hubs and castor wheels (Fig. 69).

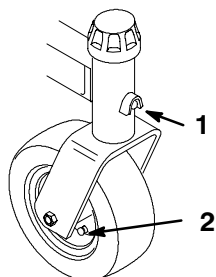

m-4846

Figure 69

- Carrier Frame Castor Hub Grease Fitting
- Castor Wheel Grease Fitting

## Deck Gearbox Fluid

Change fluid:

- After initial 100 operating hours.

**Note:** Fluid will not have to be changed again after initial 100 hour fluid change.

Fluid Type: Automatic Transmission Fluid (Dexron® III or equivalent)

**IMPORTANT: Do not mix fluids. Use only Automatic Transmission Fluid.**

Gearbox Capacity: 129.6 ml (5-1/2 oz.) each box

Check fluid: After every 100 operating hours.

## Changing Gearbox Fluid

The gearbox fluid must be changed after first 100 operating hours. Change all three gearboxes.

**IMPORTANT: Do not mix fluids. Use only Automatic Transmission Fluid.**

- Warm the fluid in gearbox. Run the mower deck for a few minutes.
- Tilt mower into the vertical position, refer to; Tilting the Mower, page 25.
- With deck raised, remove plug on the bottom side of the gearbox. Let fluid fully drain into a pan. (Fig. 70).
- Reinstall the bottom plug into the gearbox. Use pipe thread sealant if needed (Fig. 70).
- Remove the top plug to fill gearbox (Fig. 70).
- Fill gearbox with 129.6 ml (5-1/2 ounces) of automatic transmission fluid (Dexron® III or equivalent).
- Reinstall the top plug into the gearbox (Fig. 70).
- Repeat for remaining gearboxes.

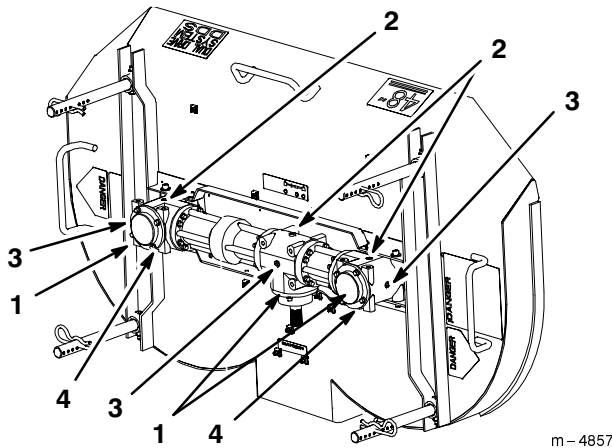

**Figure 70**

- |             |                |
|-------------|----------------|
| 1. Gearbox  | 3. Side plug   |
| 2. Top plug | 4. Bottom plug |

## Checking Gearbox Fluid

The gearbox fluid must be checked after every 100 operating hours. Check all three gearboxes.

1. Warm the fluid in gearbox. Run the mower deck for a few minutes.
2. Tilt mower into the vertical position, refer to; Tilting the Mower, page 25.
3. Remove plug on the side of the gearbox. The fluid level must be up to side hole in gearbox (Fig. 70).
4. If needed, fill automatic transmission fluid (Dexron® III or equivalent) into top hole until it runs out the side hole in gearbox. It is full when it runs out the side hole (Fig. 70).

**IMPORTANT: Do not mix fluids. Use only Automatic Transmission Fluid. Do not overfill gearboxes.**

5. Reinstall the top and side plugs into gearbox using pipe sealant (Fig. 70).
6. Fill gearbox with automatic transmission fluid (Dexron® III or equivalent).
7. Repeat for remaining gearboxes.

## Replacing the Castor Wheel Fork Bushings

The castor wheel forks are mounted in bushings pressed into the top and bottom of the carrier frame castor tubes. To check the bushings, move the castor forks back and forth and side-to-side. If a castor fork is loose, the bushings are worn and must be replaced.

1. Tilt mower into the vertical position, refer to; Tilting the Mower, page 25.
2. Remove the cap, thrust washer and 12.7mm (1/2") spacer from the top of the castor wheel fork (Fig. 71).
3. Pull the castor wheel fork out of the mounting tube, leaving the 25.4 (1") spacer and thrust washers on the fork. Remember the location of thrust washers on each fork to ensure correct installation, and to maintain a level deck.

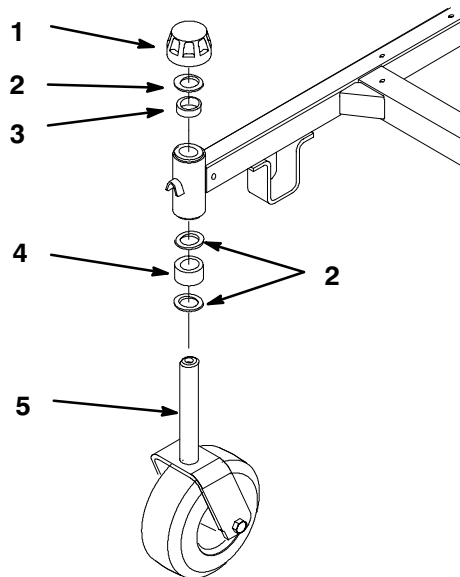

**Figure 71**

- |                             |                      |
|-----------------------------|----------------------|
| 1. Cap                      | 4. 1" (26mm) Spacer  |
| 2. Washer                   | 5. Castor Wheel Fork |
| 3. 1/2" (13mm) Spacer (New) |                      |

4. Insert a pin punch into the castor hub and carefully drive out the bushings (Fig. 72). Clean the inside of the mounting tube.
  5. Grease the inside and outside of the new bushings. Use a hammer and flat plate to carefully drive the bushings into the castor hub (Fig. 72).
  6. Inspect the castor wheel fork for wear and replace if necessary (Fig. 71).
  7. Slide the castor wheel fork through the bushings in the castor hub. Replace the 12.7 (1/2") spacer and thrust washer onto the fork and secure with the cap (Fig 71).
- IMPORTANT: The inside diameter of the bushings may collapse slightly when installed. If the castor wheel fork does not slide into the new bushings, ream both bushings to an inside diameter of 28.6mm (1.126 in.).**
8. Grease the fitting on the carrier frame castor hub using No. 2 general purpose lithium base or molybdenum base grease.

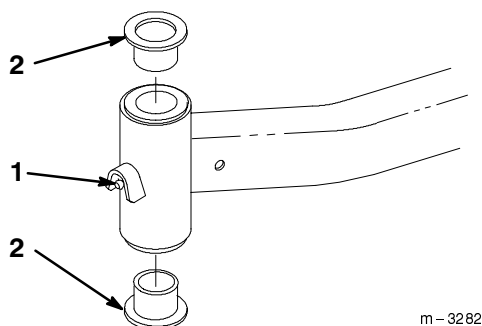

m-3282

**Figure 72**

1. Carrier Frame Castor Hub      2. Bushing

## Servicing the Castor Wheels Tail Wheel and Bearings

The castor wheels and tail wheel rotate on a roller bearing supported by a spanner bushing. If the bearing is kept well lubricated, wear will be minimal. Failure to keep the bearing well lubricated will cause rapid wear. A wobbly castor wheel usually indicates a worn bearing.

1. Remove the locknut and wheel bolt holding the castor wheel to the castor fork (Fig. 73).
2. Remove the washer and bushing, then pull the spanner bushing and roller bearing out of the wheel hub (Fig. 73).
3. Remove the other bushing from the wheel hub and clean any grease and dirt from the wheel hub (Fig. 73).
4. Inspect the roller bearing, bushings, spanner bushing and inside of the wheel hub for wear. Replace any defective or worn parts (Fig. 73).
5. To assemble, place one (1) bushing into the wheel hub. Grease the roller bearing and spanner bushing and slide them into the wheel hub. Place the second bushing into the wheel hub (Fig. 73).
6. Install the castor wheel into the castor fork and secure with the wheel bolt and locknut. Tighten the locknut until the spanner bushing bottoms against the inside of the castor forks (Fig. 73).
7. Grease the fitting on the castor wheel.

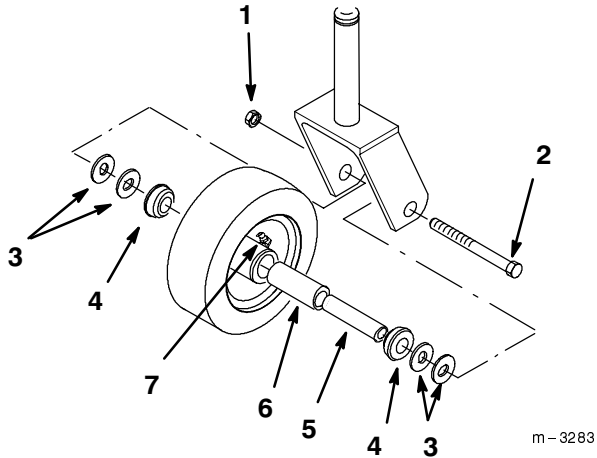

**Figure 73**

- |               |                    |
|---------------|--------------------|
| 1. Locknut    | 5. Spanner Bushing |
| 2. Wheel Bolt | 6. Roller Bearing  |
| 3. Washer     | 7. Grease fitting  |
| 4. Bushing    |                    |

m-3283

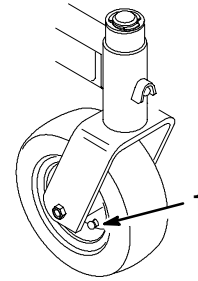

**Figure 75**

1. Castor Wheel Valve Stem

m-3281

## Tire Pressure

Maintain the air pressure in the front and rear tires as specified. Uneven tire pressure can cause uneven cut. Check the pressure at the valve stem after every 50 operating hours or monthly, whichever occurs first (Fig. 74 and 75). Check the tires when they are cold to get the most accurate pressure reading.

Pressure: 83 kPa (12 psi) drive wheels  
 83 kPa (12 psi) tail wheel  
 345 kPa (45 psi) castor wheels

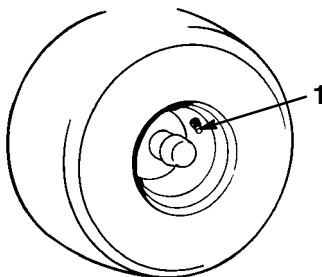

**Figure 74**

1. Drive Wheel and Tail Wheel Valve Stem

m-1872

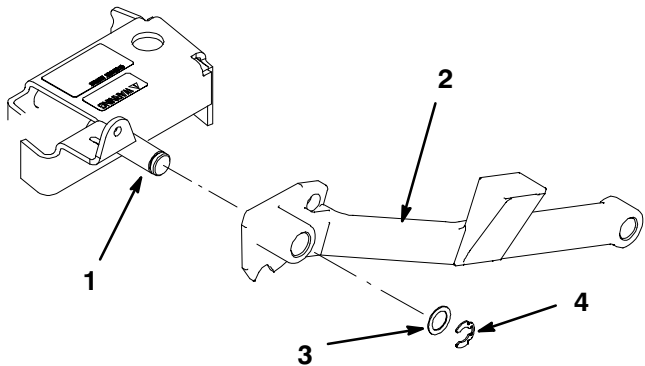

**Figure 76**

- |             |                               |
|-------------|-------------------------------|
| 1. Pin      | 3. Flat washer 38 mm (1-1/2") |
| 2. Push arm | 4. Retaining ring             |

m-4871

4. Insert a pin punch into the push arm and carefully drive out the bushings (Fig. 77). Clean the inside of the push arm.
5. Use a hammer and flat plate to carefully drive new bushings into the end of push arm (Fig. 77).
6. Place push arm onto carrier frame pin and secure with 38 mm (1-1/2") flat washer and retaining ring (Fig 76).
7. Grease the fitting on the push arm using No. 2 general purpose lithium base or molybdenum base grease.

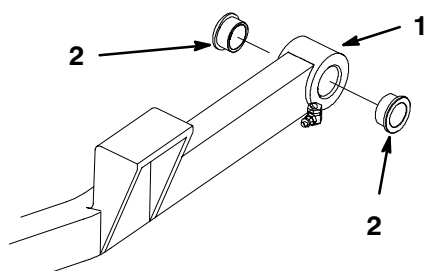

Figure 77

m-3284

1. Push arm
2. Bushing

## Hydraulic System

### Checking the Hydraulic Fluid

Check the hydraulic fluid level before engine is first started and after every 8 operating hours.

Fluid Type: Mobil Fluid 424 (ISO 46) or equivalent anti-wear hydraulic fluid.

**IMPORTANT: Use only hydraulic oils specified. Other fluids could cause system damage.**

Tank Capacity: 5.7 l (6 qt.)

1. Position machine on a level surface and stop the engine and set the parking brake.
2. Clean area around filler neck of hydraulic tank (Fig. 78).

3. Remove cap from filler neck and look inside to check fluid level. Fluid level should be above the bottom of the screen (Fig. 78).
4. If level is low, add fluid to raise level to above the bottom of the screen (Fig. 78).
5. Install cap on filler neck.

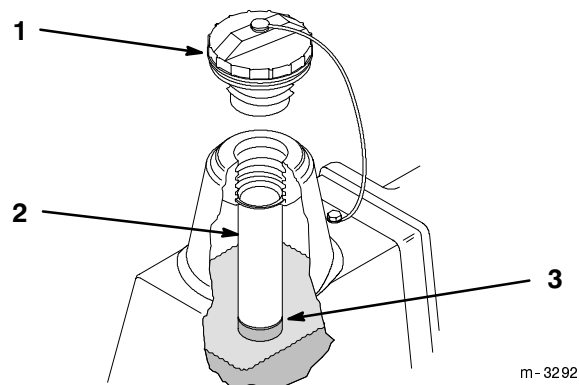

m-3292

Figure 78

1. Hydraulic reservoir cap
2. Screen
3. Fluid level-Full

## Replacing the Hydraulic Filter

Change the hydraulic filter:

- After the first 8 operating hours.
  - After every 200 operating hours.
1. Position machine on a level surface, stop the engine, and remove key from ignition switch.
 

**IMPORTANT: Do not substitute automotive oil filter or severe hydraulic system damage may result.**
  2. Remove hydro cap and temporarily cover opening with a plastic bag and rubber band to prevent all hydro fluid from draining out.
  3. Place drain pan under filter, remove the old filter and wipe the filter adapter gasket surface clean (Fig. 79).

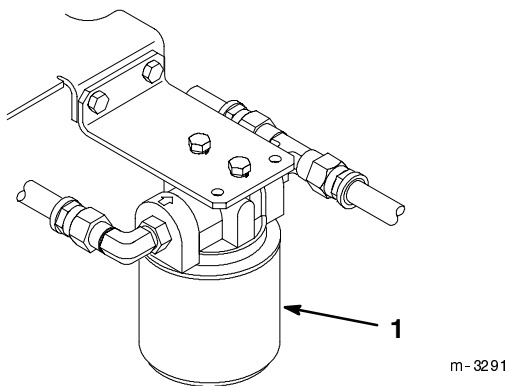

**Figure 79**

1. Hydraulic filter

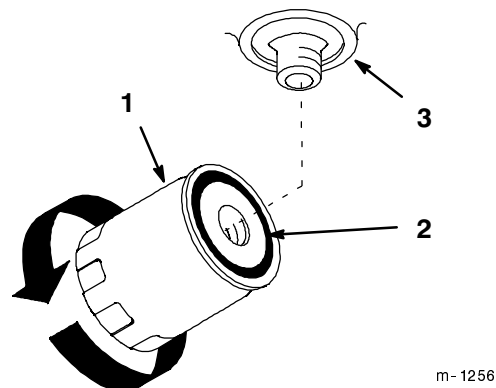

**Figure 80**

1. Hydraulic filter
2. Gasket
3. Adapter

4. Apply a thin coat hydro fluid to the rubber gasket on the replacement filter (Fig. 80).
5. Install replacement hydraulic filter onto the filter adapter. Do not tighten.
6. Remove plastic bag from tank opening and allow filter to fill with hydro fluid.
7. When fluid overflows filter turn the oil filter clockwise until the rubber gasket contacts the filter adapter, then tighten the filter an additional 1/2 turn (Fig. 80).
8. Clean up any spilled fluid.
9. Start engine and let run for about two minutes to purge air from the system. Stop the engine and check for leaks. If one or both wheels will not drive, refer Bleeding Hydraulic System, page 54.
10. Check fluid level in hydraulic tank and add to raise level to cover bottom of screen. **DO NOT OVER FILL.**

### Bleeding Hydraulic System

The traction system is self bleeding, however, it may be necessary to bleed the system if fluid is changed or after work is performed on the system.

1. Raise front of the machine so wheels are off the ground and support with jack stands.
2. Start the engine and run at idle speed. Engage traction on one side and spin the wheel by hand.
3. When the wheel begins to spin on its own, keep it engaged until wheel drives smoothly. (minimum 2 minute)
4. Check hydraulic fluid level as it drops and add as required to maintain proper level.
5. Repeat procedure on opposite wheel.

## Check Hydraulic Lines

After every 100 operating hours, check hydraulic lines and hoses for leaks, loose fittings, kinked lines, loose mounting supports, wear, weather and chemical deterioration. Make necessary repairs before operating.

### WARNING

#### POTENTIAL HAZARD

- Hydraulic fluid escaping under pressure can penetrate skin and cause injury.

#### WHAT CAN HAPPEN

- Fluid accidentally injected into the skin must be surgically removed within a few hours by a doctor familiar with this form of injury or gangrene may result.

#### HOW TO AVOID THE HAZARD

- Keep body and hands away from pin hole leaks or nozzles that eject high pressure hydraulic fluid.
- Use cardboard or paper to find hydraulic leaks.

## Adjust Motion Controls

If motion control levers do not align, adjustment is required. Adjust each rod separately.

1. Loosen jam nuts on pump control rod (Fig. 81).
2. Push and firmly hold motion control lever against forward stop (Fig. 81).
3. Rotate pump control rod until pump control plate is in the full forward position (Fig. 81). Motion control lever will lift off forward stop.

**IMPORTANT: Hold motion control lever firmly against forward stop to determine when pump control reaches stop.**

4. Rotate control rod 1 turn, to lengthen rod, and tighten jam nuts (Fig. 81).

**IMPORTANT: Motion control lever must contact forward stop before pump contacts internal stop or pump damage may occur.**

5. If motion control levers do not line up in neutral, identify control rod of handle closer to the seat. Rotate to lengthen this control rod a little. Tighten jam nuts.

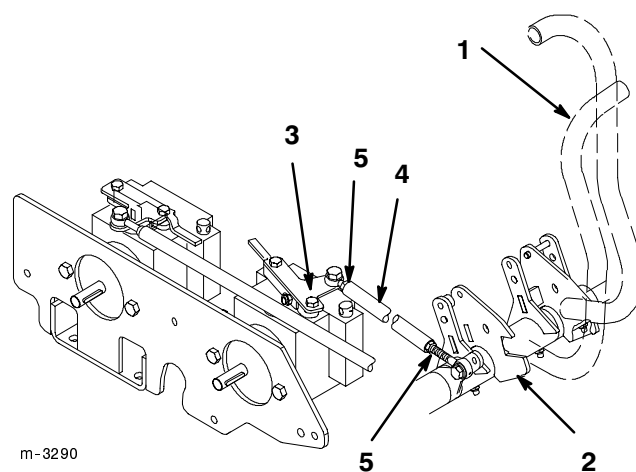

**Figure 81**

- |                         |                |
|-------------------------|----------------|
| 1. Motion control lever | 4. Control rod |
| 2. Forward stop         | 5. Jam nut     |
| 3. Pump control plate   |                |

## Replacing Power Take Off (PTO) Belts

Check power take off (PTO) belts for wear after every 50 hours of operation.

1. Remove the bumper and guard that protects the PTO belt and pulleys (Fig. 82).

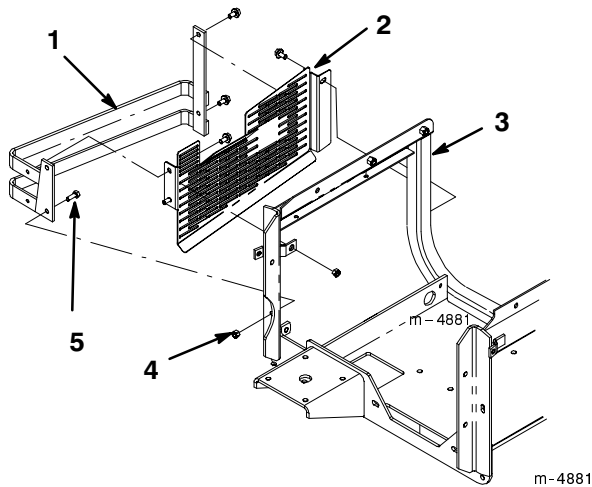

**Figure 82**

- |           |         |
|-----------|---------|
| 1. Bumper | 4. Nut  |
| 2. Guard  | 5. Bolt |
| 3. Frame  |         |

2. Hold spring loaded idler against belts and pull spring down to remove from lower bolt mount (Fig. 83).
3. Lower idler to relax tension on PTO belts and remove belts from gear box pulley (Fig. 83).
4. Remove clutch stop mounting bolts and unplug clutch wire harness (Fig. 83). Remove belts over clutch.

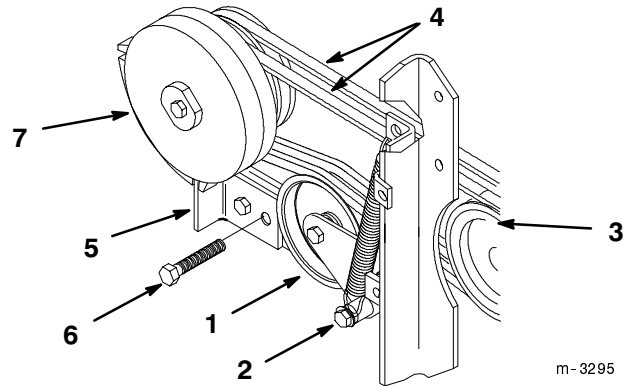

**Figure 83**

- |                    |                |
|--------------------|----------------|
| 1. Idler           | 5. Clutch stop |
| 2. Spring          | 6. Bolt        |
| 3. Gear box pulley | 7. Clutch      |
| 4. PTO belt        |                |

5. Install new PTO belts over clutch and route around gearbox pulleys and above spring loaded idler (Fig. 84).
6. Hold spring loaded idler against belts and pull spring down to install on lower bolt mount (Fig. 83).
7. Install clutch stop (Fig. 83). Tighten mounting bolts securely.
8. Plug clutch wire into wire harness.

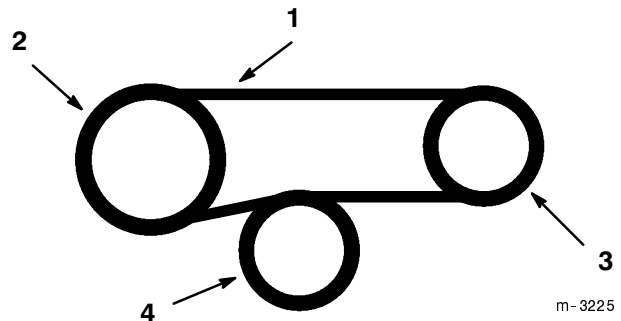

**Figure 84**

- |                   |                        |
|-------------------|------------------------|
| 1. PTO belt       | 3. Gearbox pulley      |
| 2. Clutch pulleys | 4. Spring loaded idler |

9. Reinstall bumper and guard that protects PTO belt (Fig. 82).

## Replacing the Traction Belt

Check traction drive belt for wear after every 50 hours of operation.

1. Remove PTO belts; refer to Replacing Power Take Off (PTO) Belts.
2. Push spring loaded idler down and remove traction belt from the engine, fixed idler and hydro pump pulleys (Fig. 85). Remove belt over clutch.
3. Install new belt over clutch and around engine, fixed idler and hydro pump pulleys (Fig. 85).
4. Push spring loaded idler down and align below traction belt. Release pressure on spring loaded idler (Fig. 85).
5. Install PTO belts; refer to Replacing Power Take Off (PTO) Belts.

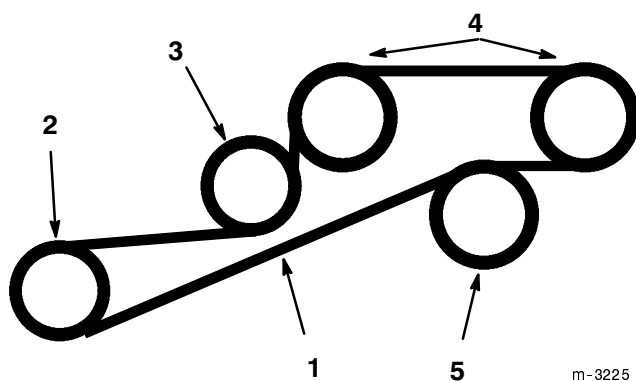

**Figure 85**

- |                       |                        |
|-----------------------|------------------------|
| 1. Traction belt      | 4. Hydro pump pulley   |
| 2. Engine pulley      | 5. Spring loaded idler |
| 3. Fixed idler pulley |                        |

## Replacing the Blower Belt

Squealing when the belt is rotating, blower slipping causing frequent clogging of chute and blower, frayed belt edges, burn marks and cracks are all signs of a worn blower belt. Replace the blower belt if any of these conditions are evident.

1. Stop the engine, remove the key and disconnect the spark plug wire(s) from the spark plug(s).
2. Push up on the spring loaded idler pulley behind PTO (power take off) gearbox to relax pressure on blower belt (Fig. 86). Lock into frame slot.
3. Remove worn blower belt.
4. Install new blower belt around PTO gearbox and blower pulleys. Then push up on the idler and place belt above idler pulley (Fig. 86).
5. Check that belt aligns with PTO, blower and idler pulleys (Fig. 86).

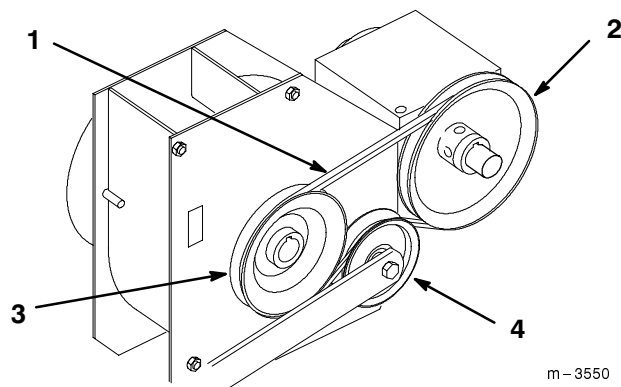

**Figure 86**

- |                       |                  |
|-----------------------|------------------|
| 1. Blower belt        | 3. Blower pulley |
| 2. PTO Gearbox pulley | 4. Idler pulley  |

## Fuse

### Service Interval/Specification

The electrical system is protected by fuses. It requires no maintenance, however, if a fuse blows check component/circuit for malfunction or short.

Fuse: Main F1-30 amp, blade-type  
Alternator F2-25 amp, blade-type  
Safety Interlock and Clutch F3-15 amp, blade-type

1. Remove dash panel screws to gain access to fuse holder (Fig. 87).
2. To replace fuses pull out on the fuse to remove it (Fig. 87).

**IMPORTANT: Do not install fuses of greater capacity as call out above. It could cause electrical system damage.**

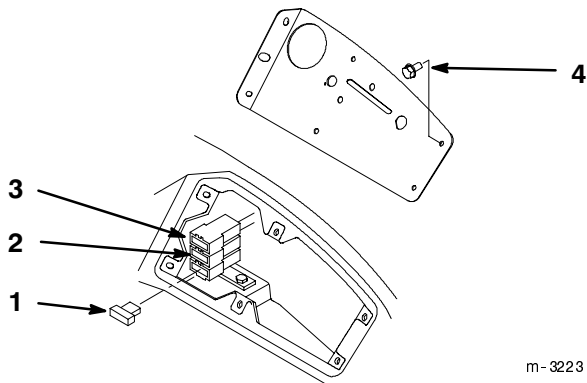

**Figure 87**

- |                      |                                       |
|----------------------|---------------------------------------|
| 1. Main-30 amp       | 3. Safety interlock and clutch-15 Amp |
| 2. Alternator-25 amp | 4. Screw                              |

## Turning Engine Lift Hook

Turn the engine lift hook if the engine is to be lifted. The engine lift hook is positioned to allow clearance for the air cleaner hose.

1. Locate on engine the lift hook in figure 88.
2. Remove the lift hook from engine. Rotate lift hook 180 degrees and reinstall.
3. Use the engine lift hook.
4. Rotate lift hook 180 degrees and reinstall to its original position.

**IMPORTANT: Return lift hook to original position after engine has been reinstalled.**

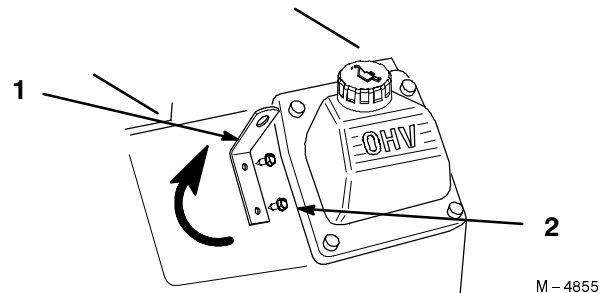

**Figure 88**

- |                     |           |
|---------------------|-----------|
| 1. Engine Lift Hook | 2. Screws |
|---------------------|-----------|

## Battery

Check the electrolyte level in the battery every 8 hours. Always keep the battery clean and fully charged. Use a paper towel to clean the battery case. If the battery terminals are corroded, clean them with a solution of four parts water and one part baking soda. Apply a light coating of grease to the battery terminals to prevent corrosion.

Voltage: 12 v, 380 Cold Cranking Amps

### Checking Electrolyte Level

1. Open covers to see into the cells. The electrolyte must be up to the lower part of the tube (Fig. 89). Do not allow the electrolyte to get below the plates. (Fig. 89).
2. If the electrolyte is low, add the required amount of distilled water; refer to Adding Water to the Battery, page 59.

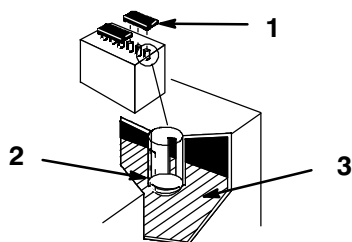

Figure 89

1. Filler caps  
2. Lower part of tube  
3. Plates

1262

### Adding Water to the Battery

The best time to add distilled water to the battery is just before you operate the machine. This lets the water mix thoroughly with the electrolyte solution.

1. Clean the top of the battery with a paper towel.
2. Lift off the filler caps (Fig. 89).
3. Slowly pour distilled water into each battery cell until the level is up to the lower part of the tube (Fig. 89).

**IMPORTANT: Do not overfill the battery because electrolyte (sulfuric acid) can cause severe corrosion and damage to the chassis.**

4. Press the filler caps onto the battery.

### Charging the Battery

**IMPORTANT: Always keep the battery fully charged (1.260 specific gravity). This is especially important to prevent battery damage when the temperature is below 0°C (32°F).**

1. Check the electrolyte level; refer to Checking Electrolyte Level, page 59.
2. Remove the filler caps from the battery and connect a 3 to 4 amp battery charger to the battery posts. Charge the battery at a rate of 4 amperes or less for 4 hours (12 volts). Do not overcharge the battery. Install the filler caps after the battery is fully charged.

### WARNING

#### POTENTIAL HAZARD

- Charging the battery produces gasses.

#### WHAT CAN HAPPEN

- Battery gasses can explode.

#### HOW TO AVOID THE HAZARD

- Keep cigarettes, sparks and flames away from battery.



# Wiring Diagram

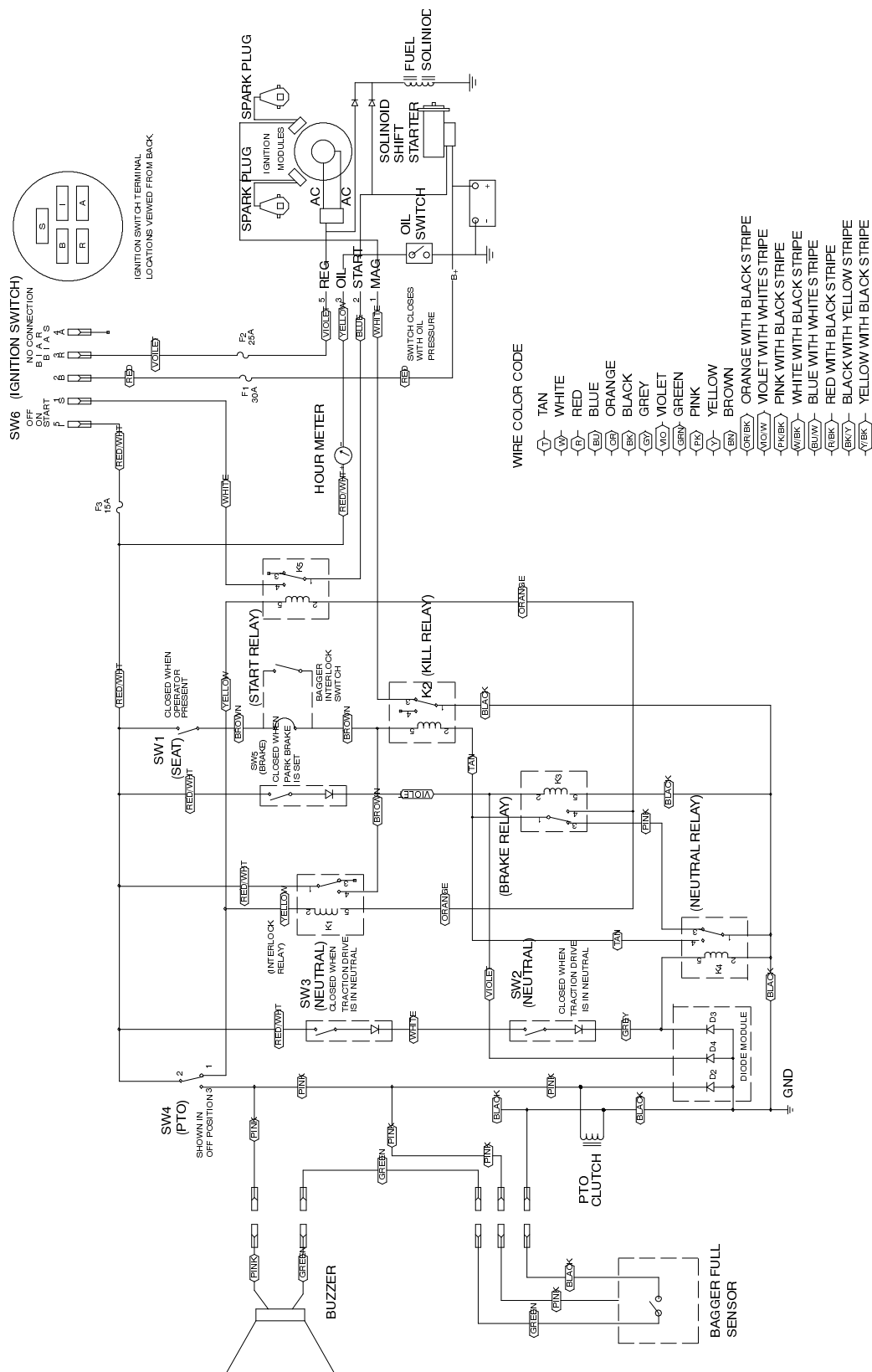

# Hydraulic Diagram

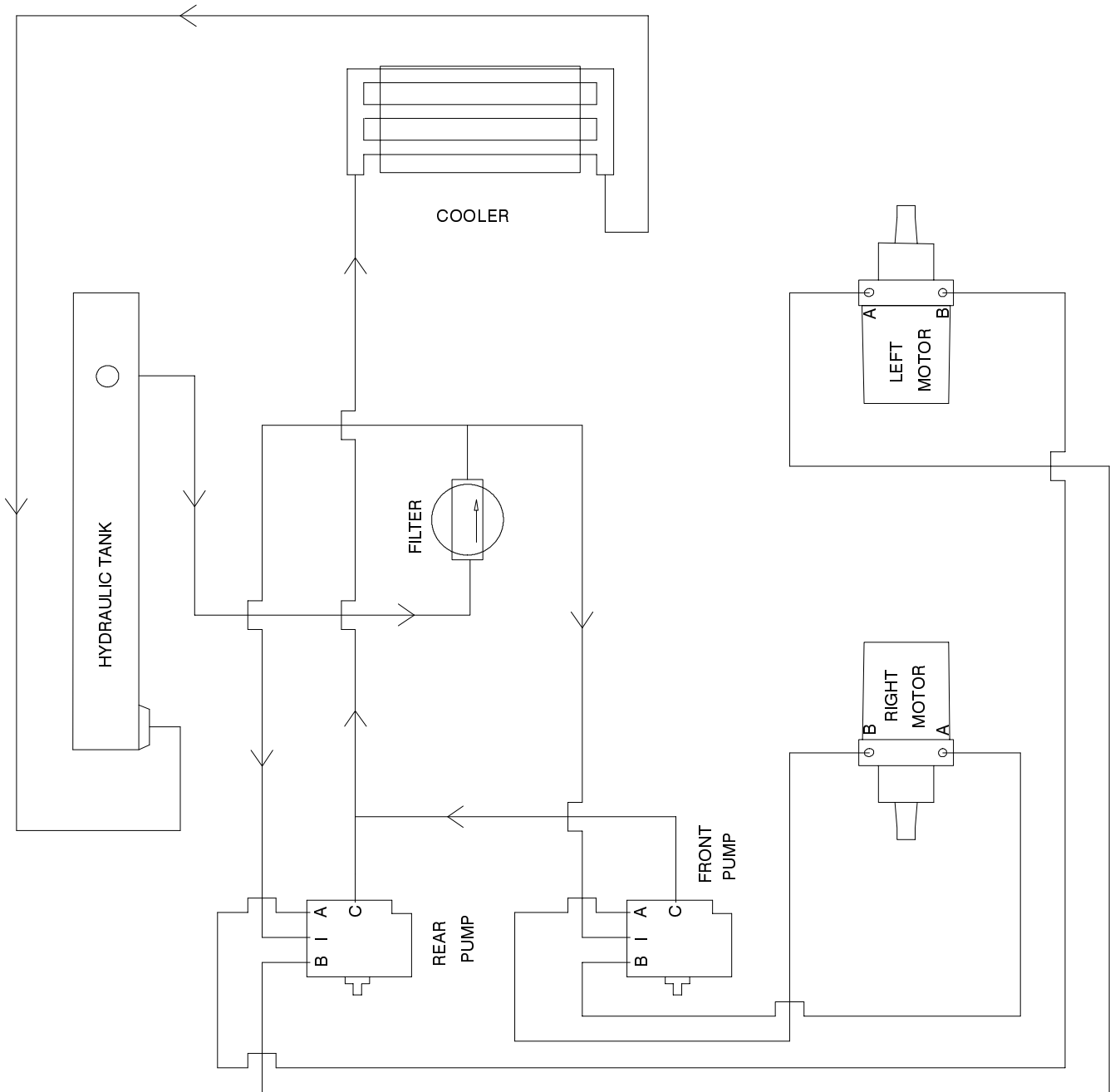

## Cleaning and Storage

1. Disengage the power take off (PTO), set the parking brake and turn the ignition key to “OFF” to stop the engine. Remove the key.
2. Remove grass clippings, dirt, and grime from the external parts of the entire machine, especially the engine. Clean dirt and chaff from the outside of the engine’s cylinder head fins and blower housing.
3. Clean any dirt and chaff from the mower, chute, blower and hopper.
4. Scrape any heavy buildup of grass and dirt from the mower, chute, blower and hopper, then wash with a garden hose.
 

**IMPORTANT: You can wash the machine with mild detergent and water. Do not pressure wash the machine. Avoid excessive use of water, especially near the control panel, engine, hydraulic pumps and motors.**
5. Check the condition of the blades. Refer to Cutting Blades on page 60.
6. Service the air cleaner; refer to Air Cleaner, page 42.
7. Grease the machine; refer to Greasing and Lubrication, page 48.
8. Change the crankcase oil; refer to Engine Oil, page 43.
9. Change the hydraulic fluid; refer to Hydraulic System, page 53.
10. Remove the spark plug(s) and check its condition; refer to Spark Plug, page 45. With the spark plug(s) removed from the engine, pour two tablespoons of engine oil into the spark plug hole. Now use the starter to crank the engine and distribute the oil inside the cylinder. Install the spark plug(s). Do not install the wire on the spark plug(s).
11. Check the condition of all belts.
12. Check the tire pressure; refer to Tire Pressure, page 52.
13. Charge the battery; refer to Battery page 59.
14. For long-term storage (more than 90 days) add stabilizer/conditioner additive to fuel in the tank ((1 oz.) per gallon).
  - A. Run engine to distribute conditioned fuel through the fuel system (5 minutes).
  - B. Stop engine, allow to cool and drain the fuel tank; refer to Fuel Tank, page 47.
  - C. Restart engine and run until it stops. Repeat, on “CHOKE” until engine will not restart.
  - D. Dispose of fuel properly. Recycle as per local codes.

**Note:** Do not store stabilizer/conditioned gasoline over 90 days.
15. Check and tighten all bolts, nuts, and screws. Repair or replace any part that is damaged or defective.
16. Paint all scratched or bare metal surfaces. Paint is available from your Authorized Service Dealer.
17. Store the machine in a clean, dry garage or storage area. Remove the key from the ignition switch and keep it in a memorable place. Cover the machine to protect it and keep it clean.

# Troubleshooting

PROBLEM	POSSIBLE CAUSES	CORRECTIVE ACTION
Starter does not crank	<ol style="list-style-type: none"> <li>1. Power take off (PTO) is ENGAGED.</li> <li>2. Parking brake is not on.</li> <li>3. Motion control levers are not in neutral.</li> <li>4. Battery is dead.</li> <li>5. Electrical connections are corroded or loose.</li> <li>6. Fuse is blown.</li> <li>7. Relay or switch is defective.</li> </ol>	<ol style="list-style-type: none"> <li>1. Move power take off (PTO) to DISENGAGED.</li> <li>2. Set parking brake.</li> <li>3. Move motion control levers into neutral.</li> <li>4. Charge the battery.</li> <li>5. Check electrical connections for good contact.</li> <li>6. Replace fuse.</li> <li>7. Contact Authorized Service Dealer.</li> </ol>
Engine will not start, starts hard, or fails to keep running.	<ol style="list-style-type: none"> <li>1. Fuel tank is empty.</li> <li>2. Choke is not ON.</li> <li>3. Air cleaner is dirty.</li> <li>4. Spark plug wires is loose or disconnected.</li> <li>5. Spark plugs are pitted, fouled, or gap is incorrect.</li> <li>6. Dirt in fuel filter.</li> <li>7. Dirt, water, or stale fuel is in fuel system.</li> </ol>	<ol style="list-style-type: none"> <li>1. Fill fuel tank with gasoline.</li> <li>2. Move choke lever to ON.</li> <li>3. Clean or replace air cleaner element.</li> <li>4. Install wires on spark plug.</li> <li>5. Install new, correctly gapped spark plugs.</li> <li>6. Replace fuel filter.</li> <li>7. Contact Authorized Service Dealer.</li> </ol>
Engine loses power.	<ol style="list-style-type: none"> <li>1. Engine load is excessive.</li> <li>2. Air cleaner is dirty.</li> <li>3. Oil level in crankcase is low.</li> <li>4. Cooling fins and air passages under engine blower housing are plugged.</li> <li>5. Spark plugs are pitted, fouled, or gap is incorrect.</li> <li>6. Dirt in fuel filter.</li> <li>7. Dirt, water, or stale fuel is in fuel system.</li> </ol>	<ol style="list-style-type: none"> <li>1. Reduce ground speed.</li> <li>2. Clean air cleaner element.</li> <li>3. Add oil to crankcase.</li> <li>4. Remove obstruction from cooling fins and air passages.</li> <li>5. Install new, correctly gapped spark plugs.</li> <li>6. Replace fuel filter.</li> <li>7. Contact Authorized Service Dealer.</li> </ol>

<b>PROBLEM</b>	<b>POSSIBLE CAUSES</b>	<b>CORRECTIVE ACTION</b>
Engine overheats.	<ol style="list-style-type: none"> <li>1. Engine load is excessive.</li> <li>2. Oil level in crankcase is low.</li> <li>3. Cooling fins and air passages under engine blower housing are plugged.</li> </ol>	<ol style="list-style-type: none"> <li>1. Reduce ground speed.</li> <li>2. Add oil to crankcase.</li> <li>3. Remove obstruction from cooling fins and air passages.</li> </ol>
Abnormal vibration.	<ol style="list-style-type: none"> <li>1. Engine mounting bolts are loose.</li> <li>2. Loose engine pulley, idler pulley, or blade pulley.</li> <li>3. Engine pulley is damaged.</li> </ol>	<ol style="list-style-type: none"> <li>1. Tighten engine mounting bolts.</li> <li>2. Tighten the appropriate pulley.</li> <li>3. Contact Authorized Service Dealer.</li> </ol>
Machine does not drive.	<ol style="list-style-type: none"> <li>1. Parking brake is on.</li> <li>2. Traction belt is worn, loose or broken.</li> <li>3. Traction belt is off pulley.</li> <li>4. Hydro fluid level low.</li> </ol>	<ol style="list-style-type: none"> <li>1. Move parking brake to off.</li> <li>2. Contact Authorized Service Dealer.</li> <li>3. Contact Authorized Service Dealer.</li> <li>4. Add hydro fluid to reservoir.</li> </ol>

