



**Z Master<sup>®</sup>**  
**with Mower and Bagger**  
Model No. 74195 – 20000001 and Up

## Parts Catalog

### Ordering Replacement Parts

To order replacement parts, please supply: the part number, the quantity, and the description of each part desired.

### Understanding Reference Numbers

Each identified part in an illustration has a reference number. The reference number for a part also appears in the parts list, along with other information about the part.

This catalog uses two special reference number formats, one to indicate parts in a service assembly and another to indicate the quantity of a given part in an illustration.

### Service Assembly Reference Numbers

Parts in service assemblies have reference numbers in the form **a:b**. The **a** represents the reference number of the entire service assembly and the **b** represents a sequential number unique to each part within the service assembly.

For example, a wheel assembly might be identified by reference number **6**, the tire by **6:1**, the valve by **6:2**, and the wheel by **6:3**. When you order the assembly identified by reference number **6**, you receive all parts identified by reference numbers **6:1**, **6:2**, and **6:3**. However, you may also order any part individually.

Reference numbers of this type appear in illustrations and in part lists.

### Reference Numbers Indicating Quantity

In an illustration, if a reference number indicates more than one part, the reference number has the form **nX y**. The **n** represents the quantity of the part, the **X** is the multiplication symbol, and the **y** represents the reference number.

For example, in an illustration, the reference number **2X 37** means that two of the parts identified by reference number **37** are indicated.

## Contents

<b>Description</b>	<b>Page</b>	<b>Description</b>	<b>Page</b>
Traction Frame Assembly .....	3	Air Cleaner and Bagger Frame Assembly .....	21
Tail, Wheel and Bumper Assembly .....	4	Bagger Assembly .....	22
Engine and Fuel Assembly .....	5	Electric Schematic .....	23
Hydraulic Oil Cooler Assembly .....	6	Hydraulic Schematic .....	24
Hydraulic Assembly .....	7	Crankshaft (Kohler CH20S PS64644) .....	25
Electrical Assembly .....	8	Crankcase (Kohler CH20S PS64644) .....	26
Electrical Assembly #2 .....	9	Oil Pan / Lubrication (Kohler CH20S PS64644)	27
Parking Brake Assembly .....	10	Head / Valve / Breather (Kohler CH20S PS64644)	28
Steering Control Assembly .....	11	.....	28
Seat Assembly .....	12	Ignition / Electrical (Kohler CH20S PS64644) ..	29
Exhaust Assembly .....	13	Blower Housing & Baffles (Kohler CH20S PS64644)	30
PTO and Hydro Drive Assembly .....	14	.....	30
Gearcase Assembly No. 100–5842 .....	15	Starting System (Kohler CH20S PS64644) .....	31
Carrier Frame Assembly .....	16	Fuel System (Kohler CH20S PS64644) .....	32
Deck Assembly .....	17	Engine Controls (Kohler CH20S PS64644) .....	33
Gearbox Assembly 100–2419 .....	18	Air Intake / Filtration (Kohler CH20S PS64644)	34
Plenum Assembly .....	19	Exhaust (Kohler CH20S PS64644) .....	35
Blower Assembly .....	20		

## Part Description Abbreviations

Part descriptions in this catalog may include the following abbreviations.

<b>Abbreviation</b>	<b>Meaning</b>	<b>Abbreviation</b>	<b>Meaning</b>
AR .....	as required	INC .....	incorporated
ASM .....	assembly	LH .....	left hand
CARR .....	carriage	NI .....	nylon insert
DEG .....	degrees	PPH .....	Phillips pan head
FH .....	flat head	PTH .....	Phillips truss head
GA .....	gauge	PTO .....	power take off
HF .....	hex flange	RH .....	right hand
HH .....	hex head	SFH .....	slotted fillister head
HHF .....	hex head flange	SHH .....	slotted hex head
HLH .....	hex lag head	SQH .....	square head
HJ .....	hex jam	SHWH .....	slotted hex washer head
HOC .....	height-of-cut	SPH .....	slotted pan head
HS .....	hex socket	SRH .....	slotted round head
HSBH .....	hex socket button head	STD .....	standard
HSFH .....	hex socket flat head	TAP .....	self tapping
HSH .....	hex socket head	TTH .....	Torx truss head
HWH .....	hex washer head	WH .....	wing head
HWHTF .....	hex washer head thread forming		

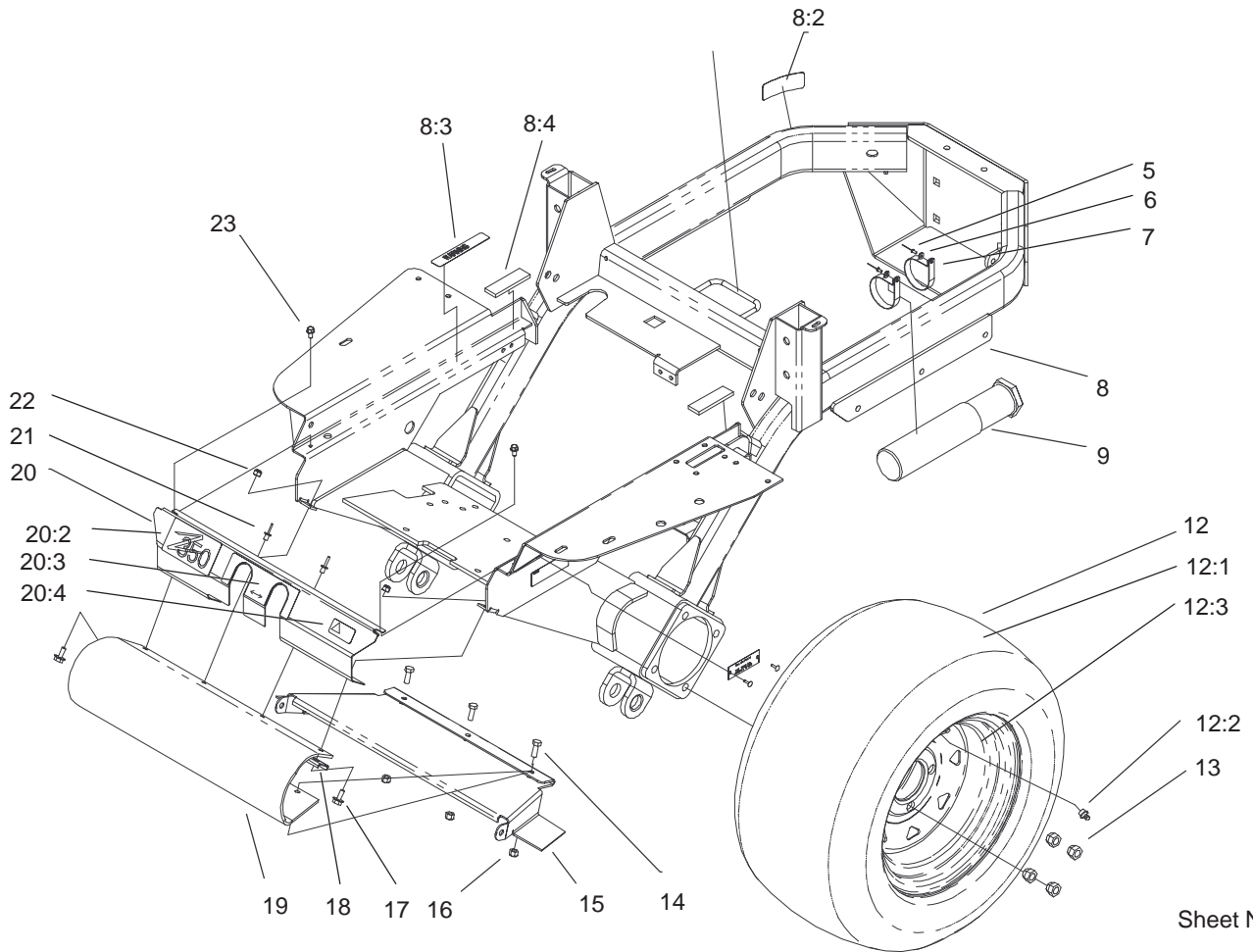

Sheet No.:2

## Traction Frame Assembly

Ref. No.	Part No.	Qty.	Description
5	3269-8	2	Rivet
6	3256-21	2	Washer-Flat
7	2412-120	2	R-Clamp
8	98-1976	1	Frame ASM w/ Decals
8:2	93-1265	1	Decal - Hot Surface
8:3	98-1977	1	Decal - Warning
8:4	52-5260	2	Rubber Pad
9	74-0720	1	Tube-Manual
12	94-9380	2	Tire And Wheel ASM
12:1	94-9387	1	Tire
12:2	232-27	1	Stem-Valve
12:3	94-9386	1	Wheel
13	242-50	8	Nut-Lug
14	322-4	3	Screw-HH
15	100-9614-01	1	Cover - Driveshaft
16	3296-29	3	Nut-Lock, NI
17	3234-4	2	Screw-HHF
18	100-9620-03	1	Bracket - Guard
19	100-9619	1	Guard - Footrest
20	104-2402	1	Cover Plate ASM w/ Decals
20:2	100-7789	1	Decal - Z350
20:3	98-1974	1	Decal - Operation
20:4	98-4387	1	Decal-Protection, Ear
21	3290-412	2	Rivet

Ref. No.	Part No.	Qty.	Description
22	32128-33	2	Nut-HF
23	32144-4	2	Screw-HH

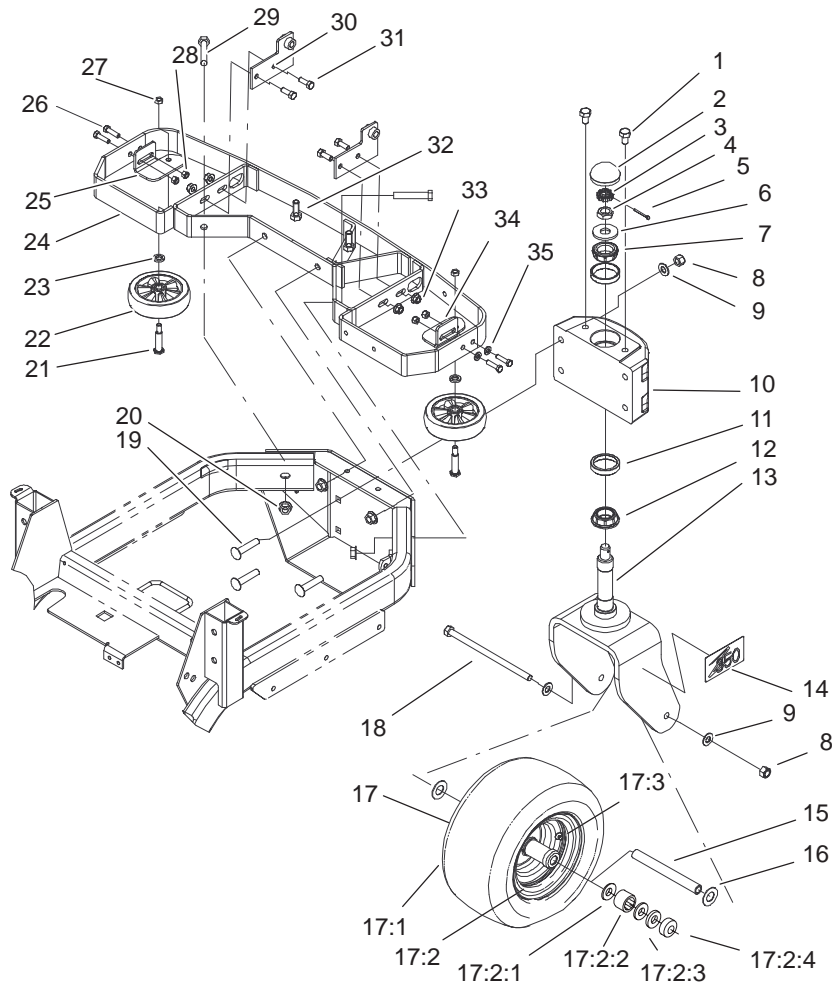

Sheet No.:3

## Tail, Wheel and Bumper Assembly

Ref. No.	Part No.	Qty.	Description
1	325-2	2	Screw-HH
2	94-4665	1	Dustcap
3	93-0307	1	Nut Retainer-Lock
4	3220-7	1	Nut-Jam
5	3272-17	1	Pin-Cotter
6	3256-8	1	Washer-Flat
7	254-62	1	Roller Brg Cone
8	3296-23	5	Nut-Lock, NI
9	3256-26	6	Washer-Flat
10	94-9489-01	1	Housing - Spindle
11	254-61	2	Cup-Bearing
12	254-70	1	Cone-Bearing
13	94-4647-01	1	Caster Fork ASM
14	100-7789	1	Decal - Z350
15	94-4753	1	Tube - Spacer,Castor
16	3256-39	2	Washer-Flat
17	98-4352	1	Tire And Wheel ASM
17:1	94-9384	1	Tire
17:2	98-4351	1	Wheel ASM
17:2:1	99-0246	4	Washer-Stop
17:2:2	99-0247	2	Bearing-Roller
17:2:3	99-0248	2	Seal-Felt
17:2:4	99-0249	2	Cap-End
17:3	232-27	1	Stem-Valve
18	325-24	1	Screw-HH
19	3233-27	4	Screw-CARR

Ref. No.	Part No.	Qty.	Description
20	32128-23	4	Nut-HF
21	5188	2	Bolt-Shoulder
22	109375	2	Wheel ASM
23	9202424	2	Spacer
24	104-0358-03	1	Bumper ASM
25	100-7772-03	1	Bracket - Roller, RH
26	322-6	4	Screw-HH
27	32153-2	2	Nut-Lock
28	32128-20	4	Nut-HF
29	325-11	2	Screw-HH
30	100-9613-03	2	Pivot Plate ASM
31	323-6	4	Screw-HH
32	325-5	2	Screw-HH
33	32128-21	4	Nut-HF
34	100-7779-03	1	Bracket - Roller, LH
35	3256-23	4	Washer-Flat

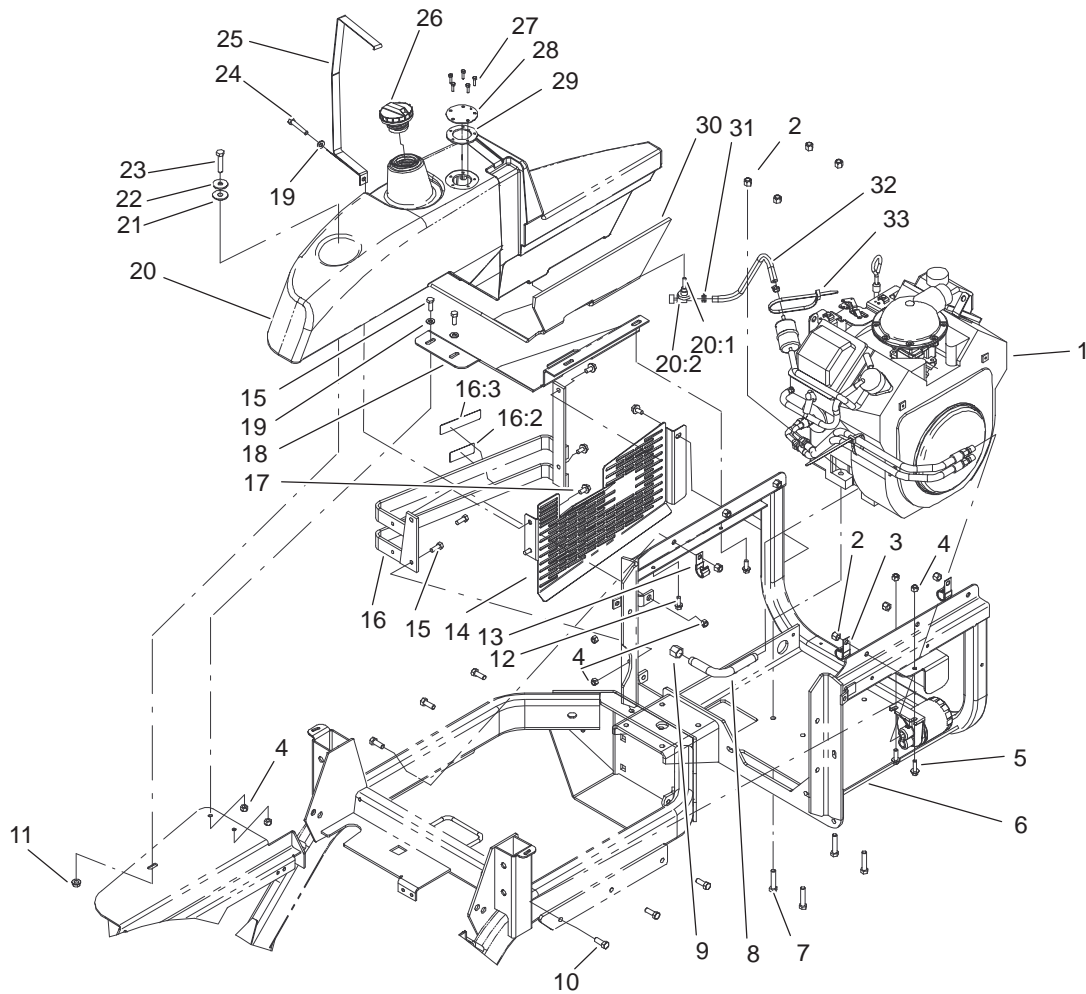

Sheet No.:4

## Engine and Fuel Assembly

Ref. No.	Part No.	Qty.	Description	Ref. No.	Part No.	Qty.	Description
1		1	Engine – Kohler, Ch20s Ps-64644	21	240-11	1	Grommet-Mount, Tank
2	3296-39	10	Nut-Lock, NI	22	63-8410	1	Washer
3	94-9580	2	Clamp – J	23	323-9	1	Screw-HH
4	3296-29	7	Nut-Lock, NI	24	322-10	1	Screw-HH
5	3234-17	2	Screw-HHF	25	94-4799-03	1	Strap – Fuel Tank
6	94-4618-03	1	Engine Support ASM	26	93-3101	1	Cap-Fuel
7	323-9	4	Screw-HH	27	3250-29	5	Screw-PPH
8	94-9499	1	Tube – Oil Drain	28	94-9597	1	Cover-Fuel Tank Opening
9	288-4	1	Pipe Cap	29	62-7650	1	Gasket
10	323-6	6	Screw-HH	30	98-1319	1	Foam – Fuel Tank
11	3290-357	1	Nut-Flange, Lock	31	2412-98	2	Clamp
12	32144-11	2	Screw-TAP	32	98-0976	1	Hose – Gas
13	8830	1	Clip	33	3290-378	2	Tie-Cable
14	98-1987-03	1	Guard – Belt				
15	322-4	4	Screw-HH				
16	98-4377	1	Bumper ASM w/ Decals				
16:2	93-1265	1	Decal – Hot Surface				
16:3	98-1977	1	Decal – Warning				
17	32144-14	5	Screw-HWH				
18	94-4798-01	1	Plate – Tank Support				
19	3256-23	3	Washer-Flat				
20	94-9553	1	Assembly – Fuel Tank				
20:1	104047	1	Bushing				
20:2	104048	1	Valve-Fuel				

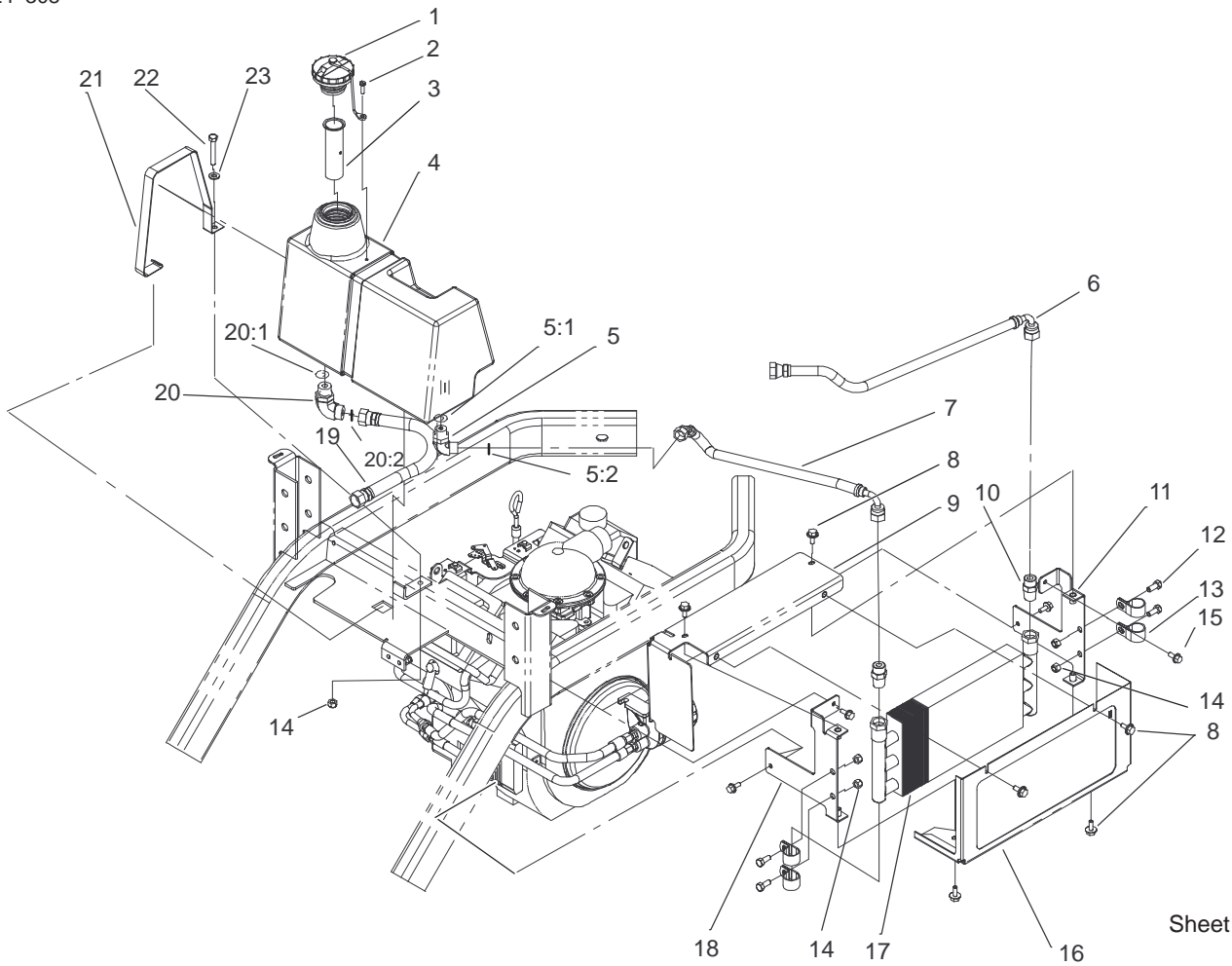

Sheet No.:5

## Hydraulic Oil Cooler Assembly

Ref. No.	Part No.	Qty.	Description
1	93-4365	1	Cap-Oil
2	3290-126	1	Screw
3	92-1705	1	Filter-Screen
4	94-4700	1	Tank - Hydraulic
5	340-98	1	Fitting-Hyd, 90°
5:1	237-79	1	O-Ring
5:2	237-30	1	O-Ring
6	94-4709	1	Hydraulic Hose ASM
7	94-4713	1	Hydraulic Hose ASM
8	3234-4	6	Screw-HHF
9	98-1969	1	Cooler Shroud ASM
10	93-5107	2	Fitting - Adapter
11	98-1972	1	Rear Cooler Bracket ASM
12	322-3	4	Screw-HH
13	2412-39	4	Clamp-R
14	3296-29	5	Nut-Lock, NI
15	32144-10	2	Screw-HWH
16	94-9556-03	1	Cooler Shroud ASM
17	24-0760	1	Cooler ASM
18	98-1971	1	Front Cooler Bracket ASM
19	94-4710	1	Hydraulic Hose ASM
20	340-105	1	Fitting-Hyd., 90°
20:1	237-80	1	O-Ring
20:2	237-30	1	O-Ring

Ref. No.	Part No.	Qty.	Description
21	94-4642-03	1	Strap - Hydraulic Tank
22	322-10	1	Screw-HH
23	3256-23	1	Washer-Flat

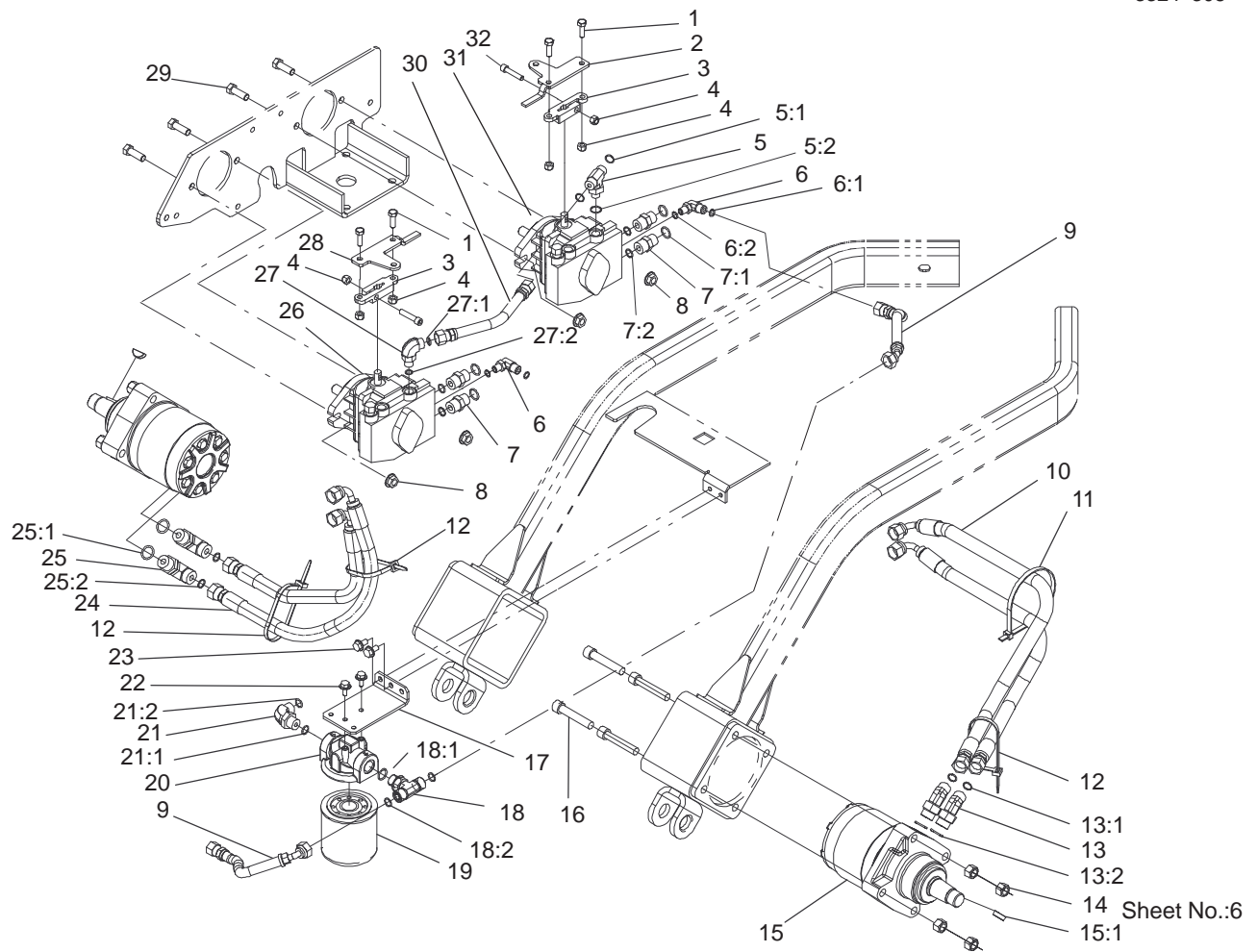

## Hydraulic Assembly

Ref. No.	Part No.	Qty.	Description
1	322-5	4	Screw-HH
2	94-4702-03	1	Plate - Control, Left
3	94-4678	2	Arm - Pump Control
4	3296-29	6	Nut-Lock, NI
5	340-94	1	Adapter
5:1	237-22	2	O-Ring
5:2	237-42	1	O-Ring
6	340-97	2	Fitting-90°
6:1	237-22	1	O-Ring
6:2	237-78	1	O-Ring
7	340-4	4	Adapter
7:1	237-30	1	O-Ring
7:2	237-79	1	O-Ring
8	32128-42	4	Nut-HF
9	98-4384	2	Hydraulic Hose ASM
10	94-4714	2	Hydraulic Hose ASM
11	3334-945	1	Tie-Cable
12	3290-378	3	Tie-Cable
13	340-89	2	Fitting-45°
13:1	237-30	1	O-Ring
13:2	237-80	1	O-Ring
14	3296-23	8	Nut-Lock, NI
15	94-4640	2	Motor - Hydraulic Wheel
15:1	3257-42	1	Key-Woodruff
16	3274-93	8	Screw-HSH

Ref. No.	Part No.	Qty.	Description
17	94-9525-03	1	Angle-Mount, Hyd Filter
18	340-157	1	Fitting-Hydraulic
18:1	237-79	1	O-Ring
18:2	237-30	2	O-Ring
19	67-8110	1	Cartridge - Filter, Oil
20	86-9080	1	Filter Head
21	340-98	1	Fitting-Hyd, 90°
21:1	237-79	1	O-Ring
21:2	237-30	1	O-Ring
22	3234-4	2	Screw-HHF
23	32144-14	2	Screw-HWH
24	94-4705	2	Hydraulic Hose ASM
25	340-105	2	Fitting-Hyd., 90°
25:1	237-80	1	O-Ring
25:2	237-30	1	O-Ring
26	98-4375	1	Pump - Hydraulic
27	340-77	1	Fitting-Hyd., 90°
27:1	237-22	1	O-Ring
27:2	237-42	1	O-Ring
28	94-4701-03	1	Plate - Control, Right
29	324-5	4	Screw-HH
30	94-4712	1	Hydraulic Hose ASM
31	98-4374	1	Pump - Hydraulic
32	3274-83	2	Screw-HSH

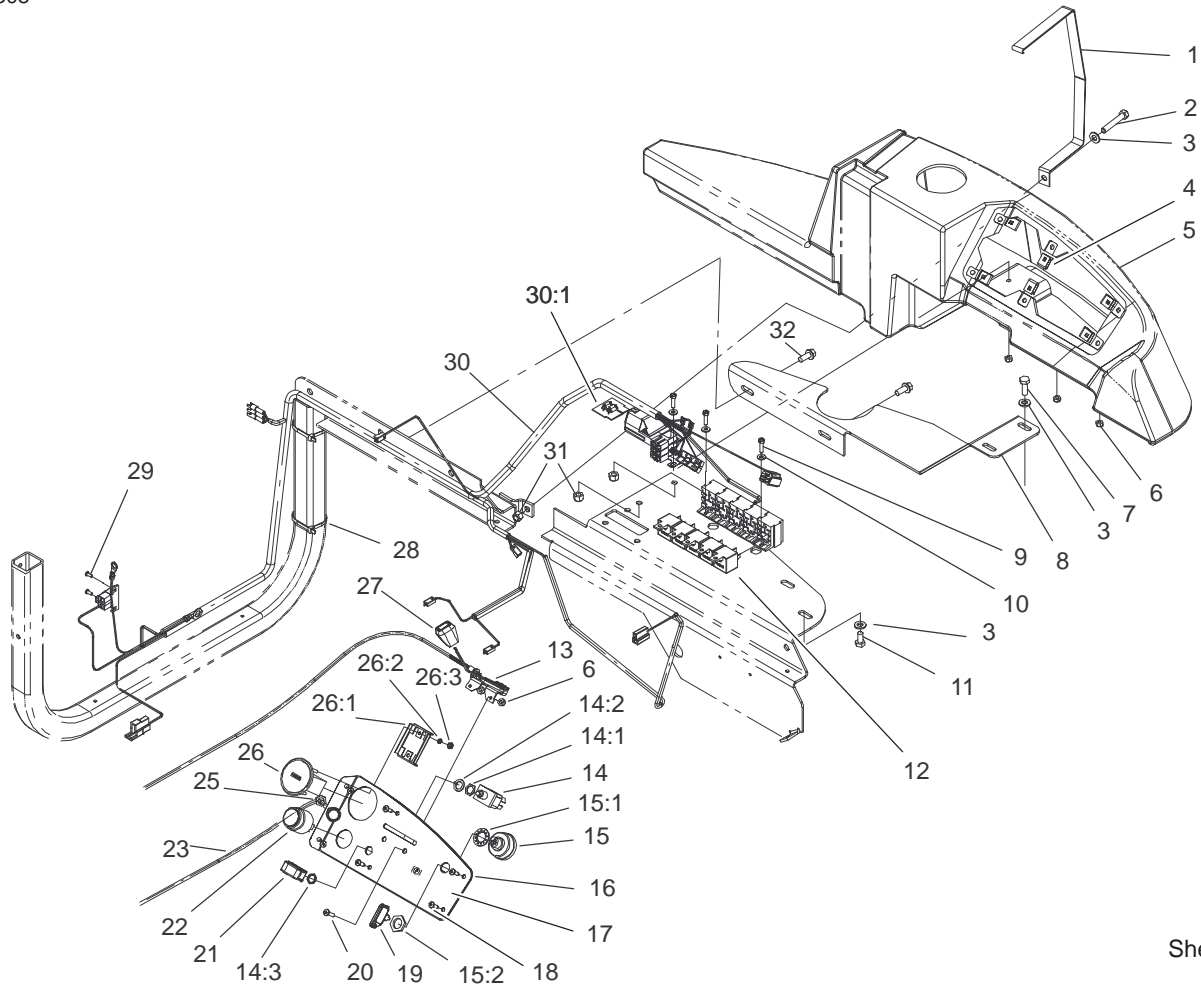

Sheet No.:7

## Electrical Assembly

Ref. No.	Part No.	Qty.	Description
1	94-9488-03	1	Strap - Console
2	322-10	1	Screw-HH
3	3256-23	5	Washer-Flat
4	95-1962	6	Clip - Tinnerman
5	104-0365	1	Console
6	3296-2	5	Nut-Lock
7	322-4	2	Screw-HH
8	100-7792-01	1	Plate - Support, Console
9	32105-13	3	Screw-SHH
10	3256-14	3	Washer-Flat
11	322-2	2	Screw-HH
12	116397	5	Relay, SPDT
13	98-4350	1	Throttle Control ASM
14	92-9811	1	Switch - Toggle, Sealed
14:1	105805	1	Nut-Hex Special
14:2	102950	1	Washer Tab
14:3	113179	1	Nut-Hex
15	111216	1	Ignition Switch ASM
15:1	9201604	1	Lockwasher
15:2	101884	1	Nut
16	98-1999-03	1	Panel - Instrument
17	98-1973	1	Decal - Instrument
18	32144-124	6	Screw - PPH, Type AB

Ref. No.	Part No.	Qty.	Description
19	62-7770	2	Key-Ignition
20	3250-13	2	Screw-PPH
21	113050	1	Cover-PTO Switch
22	80-9330	1	Alarm - Audio
23	98-1956	1	Control - Choke
25	3220-3	1	Nut-Jam
26	78-0020	1	Hour-Meter
26:1	78-3320	1	Clamp-Hour Meter
26:2	3255-25	2	Washer-Lock/Ext
26:3	3217-27	2	Nut-Hex
27	66-0120	1	Knob
28	3290-379	2	Tie-Cable
29	32144-74	2	Screw-TAP
30	98-3317	1	Harness
30:1	92-3188	1	Diode - Circuit Board
31	3296-29	3	Nut-Lock, NI
32	32144-11	2	Screw-TAP

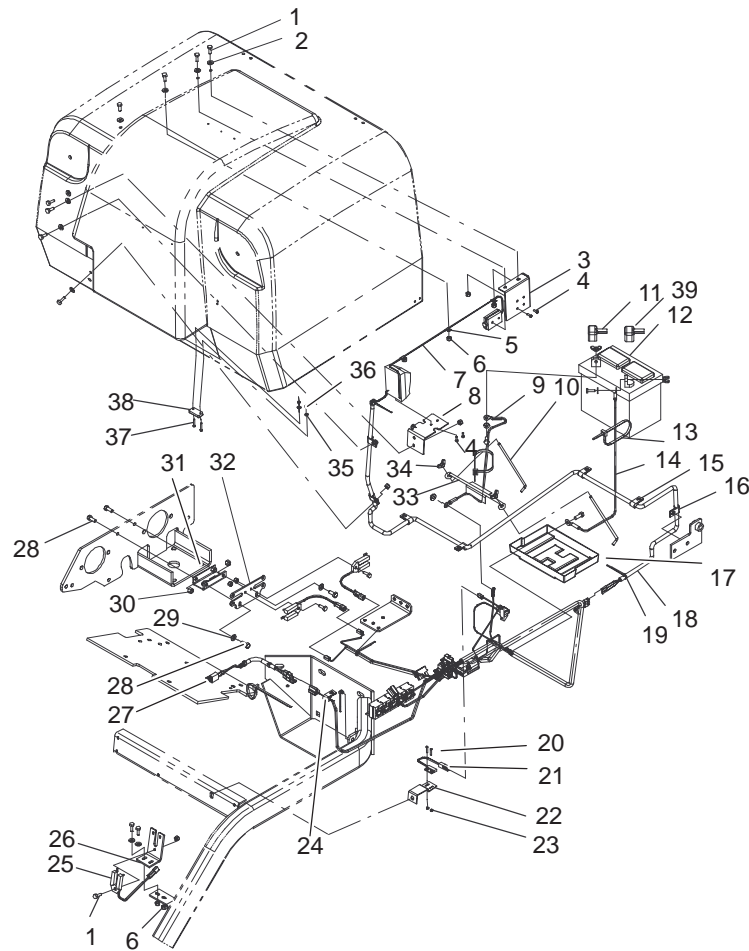

Sheet No.:8

## Electrical Assembly #2

Ref. No.	Part No.	Qty.	Description	Ref. No.	Part No.	Qty.	Description
1	321-4	15	Screw-HH	25	98-1324	3	Switch - Interrupter
2	3256-22	12	Washer-Flat	26	94-4696	1	Angle - Mount, Switch
3	100-2440-03	1	Bracket - Emitter	27	98-4373	1	Harness - Seat
4	3250-19	4	Screw-PPH				Adapter
5	2412-127	3	Clamp-R	28	322-3	4	Screw-HH
6	3296-42	13	Nut-Lock	29	3256-23	2	Washer-Flat
7	98-2367	1	Module - Obstruction Det	30	3296-29	4	Nut-Lock, NI
8	98-3000-03	1	Bracket - Receiver	31	94-4797-03	1	Channel-Mount, Switch
9	28-3893	1	Wire ASM	32	94-9460	1	Plate - Switch Mount
10	94-6146	2	Retainer - Battery	33	113010	1	Battery Hold Down
11	28-8080	1	Boot-Terminal	34	32103-22	4	Nut-Wing
12	94-1867	1	Battery	35	3256-12	2	Washer-Flat
13	3290-378	3	Tie-Cable	36	3296-9	2	Nut-Lock NI
14	92-6287	1	Wire ASM - Negative	37	3290-124	2	Screw-HH
15	2412-93	6	R-Clamp	38	98-3006	1	Actuator
16	2412-138	1	R-Clamp	39	98-0603	1	Boot - Terminal
17	106948	1	Tray-Battery				
18	98-3009	1	Conduit - Convolved				
19	3290-381	4	Tie - Cable				
20	3290-313	2	Screw - PH				
21	95-7669	1	Switch - Reed, Magnetic				
22	98-0823-03	1	Bracket - Switch				
23	3296-52	2	Nut-Lock NI				
24	2412-93	1	R-Clamp				

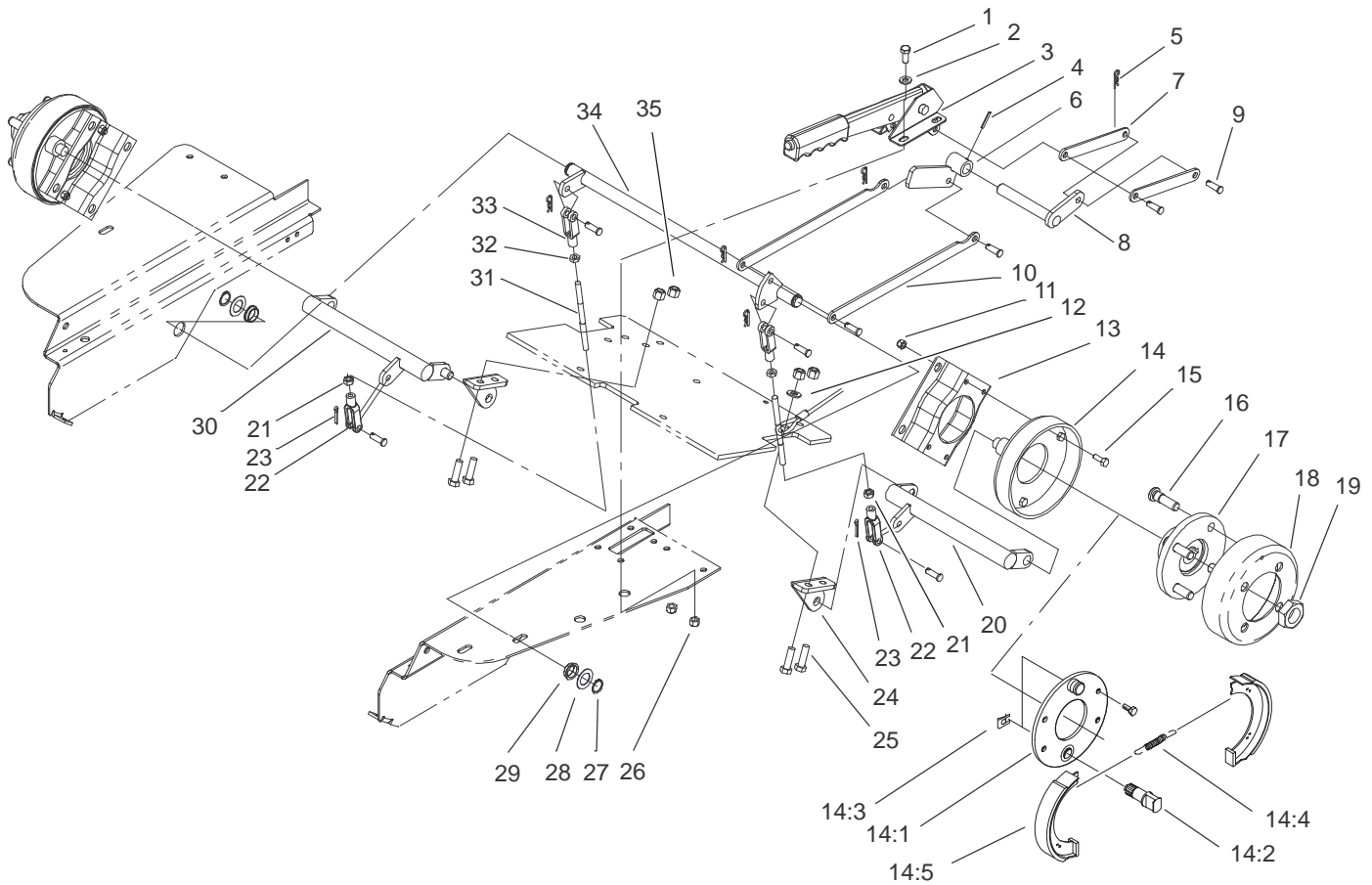

Sheet No.:9

## Parking Brake Assembly

Ref. No.	Part No.	Qty.	Description
1	322-3	4	Screw-HH
2	3256-23	4	Washer-Flat
3	94-4602	1	Lever - Brake
4	32121-93	1	Spiral Pin
5	3290-307	6	Pin-Hair
6	98-1994	1	Brake Hub ASM
7	98-1992	2	Link - Brake
8	98-1990	1	Transfer Shaft ASM
9	283-1	8	Pin-Yoke
10	98-1991	2	Link - Connect
11	3296-42	8	Nut-Lock
12	3256-24	1	Washer-Flat
13	84-2000-03	2	Bracket-Brake
14	71-1500	2	Brake ASM
14:1	70-9870	1	Plate-Backing
14:2	70-9860	1	Cam-Brake
14:3	70-9850	1	Clip-Retaining
14:4	70-9880	2	Spring-Return
14:5	70-9840	2	Shoe-Brake
15	321-4	8	Screw-HH
16	85-6540	8	Stud-Drive
17	10-6870-03	2	Hub-Wheel
18	10-6850	2	Drum-Brake
19	26-3790	2	Nut-Lock
20	98-1997	1	LH Brake Lever ASM
21	3220-20	2	Nut-Jam LH

Ref. No.	Part No.	Qty.	Description
22	98-4367	2	Clevis - Adjustable
23	3272-10	2	Pin-Cotter
24	94-9573-01	2	Mount-Lever, Brake RH
25	323-7	4	Screw-HH
26	3296-29	4	Nut-Lock, NI
27	32120-72	2	Ring-Snap
28	9202574	2	Washer-Flat
29	106950	2	Bushing
30	98-1998	1	RH Brake Lever ASM
31	98-1996	2	Rod - Brake
32	3220-2	2	Nut-Jam
33	282-2	2	Yoke
34	98-1988	1	Torsion Shaft ASM
35	3296-39	4	Nut-Lock, NI

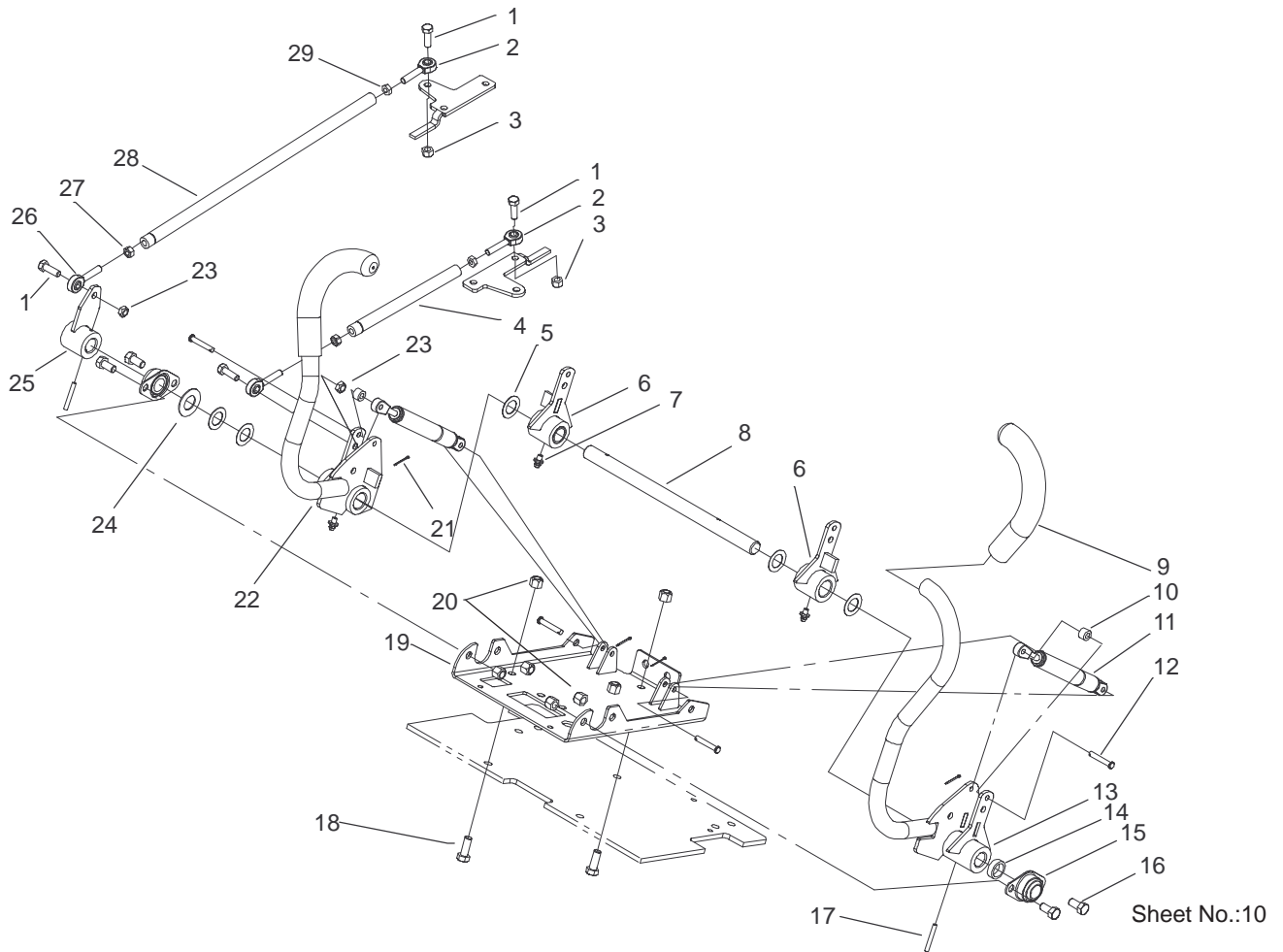

Sheet No.:10

## Steering Control Assembly

Ref. No.	Part No.	Qty.	Description	Ref. No.	Part No.	Qty.	Description
1	322-5	4	Screw-HH	24	3256-39	1	Washer-Flat
2	2411-52	2	Bearing - Rod End, RH	25	94-9594-03	1	Control Hub ASM
3	3296-29	2	Nut-Lock, NI	26	2411-53	2	Bearing - Rod End, RH
4	94-4717	1	Rod - Control, RH	27	3220-20	2	Nut-Jam LH
5	9202574	5	Washer-Flat	28	94-4718	1	Rod - Control, LH
6	94-9552	2	Center Control ASM	29	3220-2	2	Nut-Jam
7	302-5	3	Fitting - Lube				
8	94-9515	1	Shaft - Control				
9	94-9490	2	Grip - Cushion				
10	94-9593	2	Spacer - Damper				
11	98-4397	2	Damper - Bidirectional				
12	283-66	4	Pin-Clevis				
13	94-9517-03	1	LH Control Handle ASM				
14	94-9524	1	Spacer - Control				
15	27-2320	2	Bearing				
16	323-4	4	Screw-HH				
17	32121-103	2	Pin-Spring				
18	323-6	3	Screw-HH				
19	94-9591-03	1	Channel Mount ASM				
20	3296-39	7	Nut-Lock, NI				
21	3272-4	4	Pin-Cotter				
22	94-9551	1	RH Control Handle ASM				
23	3296-47	2	Nut-Lock, NI				



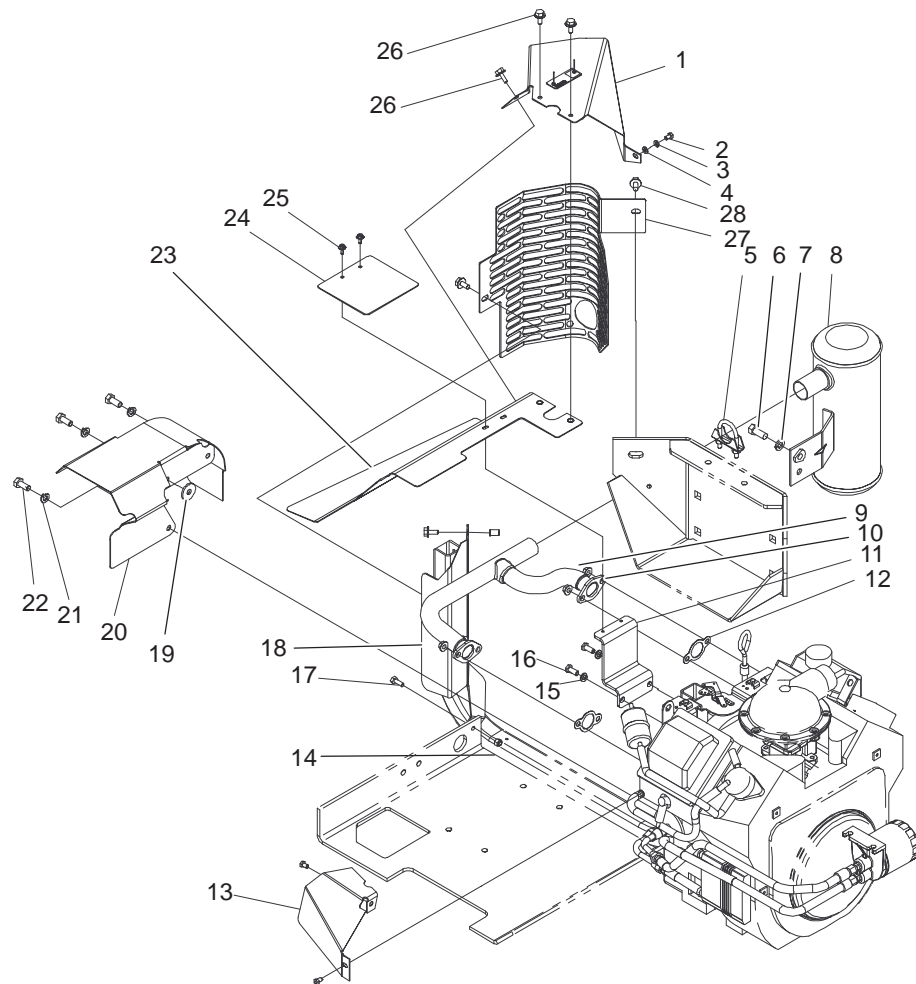

Sheet No.:12

## Exhaust Assembly

Ref. No.	Part No.	Qty.	Description	Ref. No.	Part No.	Qty.	Description
1	98-4368	1	Rear Heat Baffle ASM	25	98-4386	2	Screw-Torx PH, Thd Frm
2	42-9430	1	Bolt/Washer	26	3234-4	4	Screw-HHF
3	48-8020	1	Washer-Spring	27	98-1980-03	1	Guard - Muffler
4	33093-00	1	Washer-Flat	28	32144-14	1	Screw-HWH
5	2112-11	1	Clamp-Muffler				
6	324-4	1	Screw-HH				
7	3253-6	1	Washer-Lock/Sp				
8	94-9495	1	Muffler				
9	92-6780	4	Nut-Hex Flange				
10	94-9494	1	Manifold				
11	94-9561	1	Bracket - Manifold Shield				
12	93-0350	2	Gasket - Exhaust				
13	98-1349	1	Baffle - Heat, Front				
14	3296-42	1	Nut-Lock				
15	42-9850	2	Washer-Lock, Spring				
16	33114-020	2	Screw-HH				
17	321-4	1	Screw-HH				
18	98-1329	1	Baffle - Heat, Middle				
19	2844	1	Washer				
20	98-1326	1	Baffle - Heat, Lower				
21	3253-5	3	Washer-Lock/Sp				
22	323-5	3	Screw-HH				
23	98-1967	1	ASM - Top Heat Baffle				
24	98-1979	1	Panel - Access, Baffle				

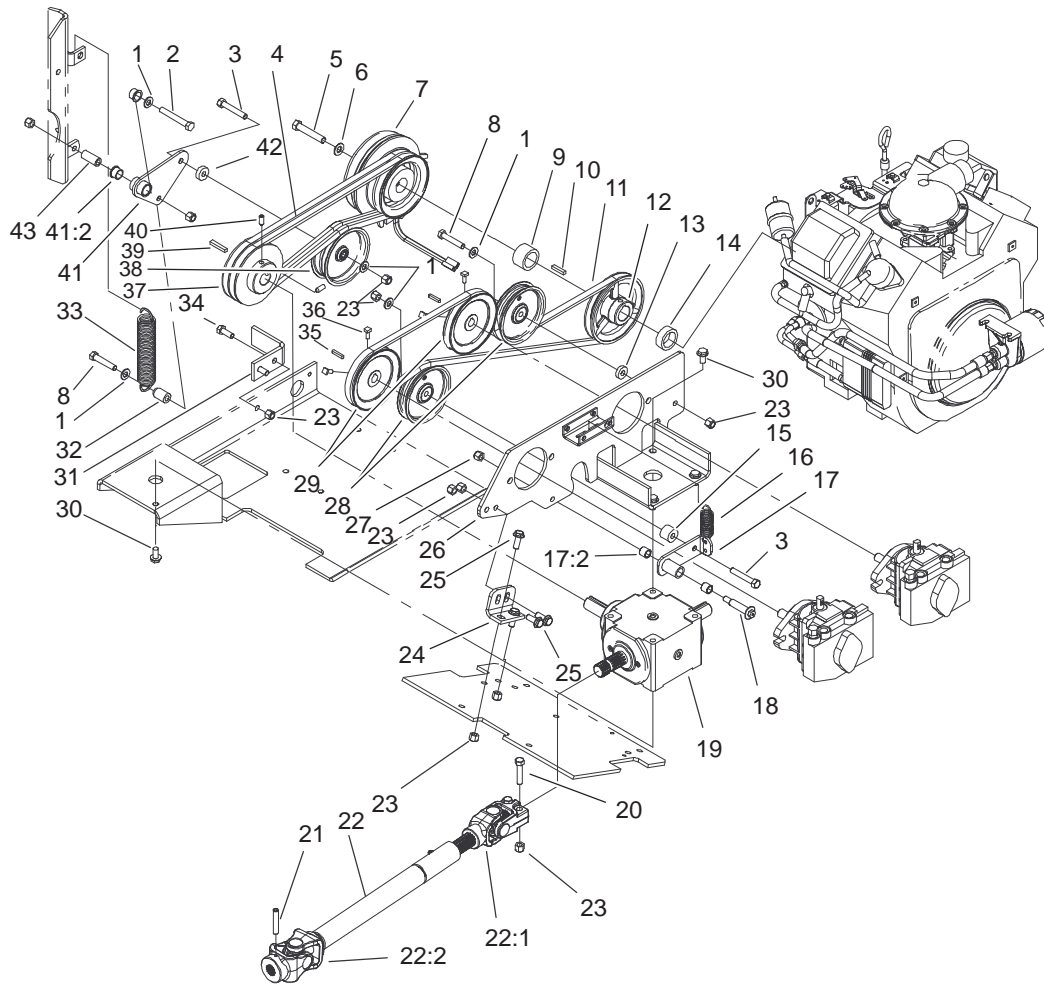

Sheet No.:13

## PTO and Hydro Drive Assembly

Ref. No.	Part No.	Qty.	Description
1	3256-24	5	Washer-Flat
2	323-13	1	Screw-HH
3	323-11	2	Screw-HH
4	94-4608	1	V-Belt, Matched Pair
5	3212-10	1	Screw-HH
6	3256-25	1	Washer-Flat
7	94-4632	1	Clutch - Electromagnetic
8	323-10	2	Screw-HH
9	94-4689	1	Spacer - Shaft, Engine
10	5-0698	1	Key
11	94-4607	1	V-Belt
12	94-4628	1	Pulley - Engine
13	9202204	1	Washer
14	94-4688	1	Spacer - Shaft, Engine
15	94-4792	1	Spacer - Idler Arm
16	94-9599	1	Spring - Extension
17	95-1950	1	Idler Arm ASM w/ Bushings
17:2	256-154	2	Bushing
18	27-6230	1	Bolt-Wheel
19	100-5842	1	Gearbox ASM
20	323-19	2	Screw-HH
21	32121-48	1	Pin-Spring

Ref. No.	Part No.	Qty.	Description
22	94-4722	1	Shaft - Drive
22:1	100-7765	1	Joint & Shaft Half ASM
22:2	100-7766	1	Joint & Tube Half ASM
23	3296-39	13	Nut-Lock, NI
24	94-4787-03	1	Mount - Plate, Pump
25	3234-11	4	Screw-HHF
26	94-4658-03	1	Pump Mount ASM
27	3296-6	1	Nut-Lock, NI
28	93-1622	2	Pulley-Idler
29	80-8170	2	Pulley - Pump, Traction
30	3234-1	8	Screw-HHF
31	98-1301-03	1	Stop - Clutch
32	95-1967	1	Spacer - Spring
33	88-6460	1	Spring - Extension
34	323-6	2	Screw-HH
35	80-6090	2	Key - Pump
36	3241-5	4	Screw-Set
37	94-4629	1	Pulley - Clutch
38	66-4210	1	Pulley
39	67-7490	1	Key
40	3246-6	2	Screw-Set, HSH
41	95-1968	1	Idler Arm ASM
41:2	109859	2	Bushing
42	94-4685	1	Spacer - Idler
43	114511	1	Spacer

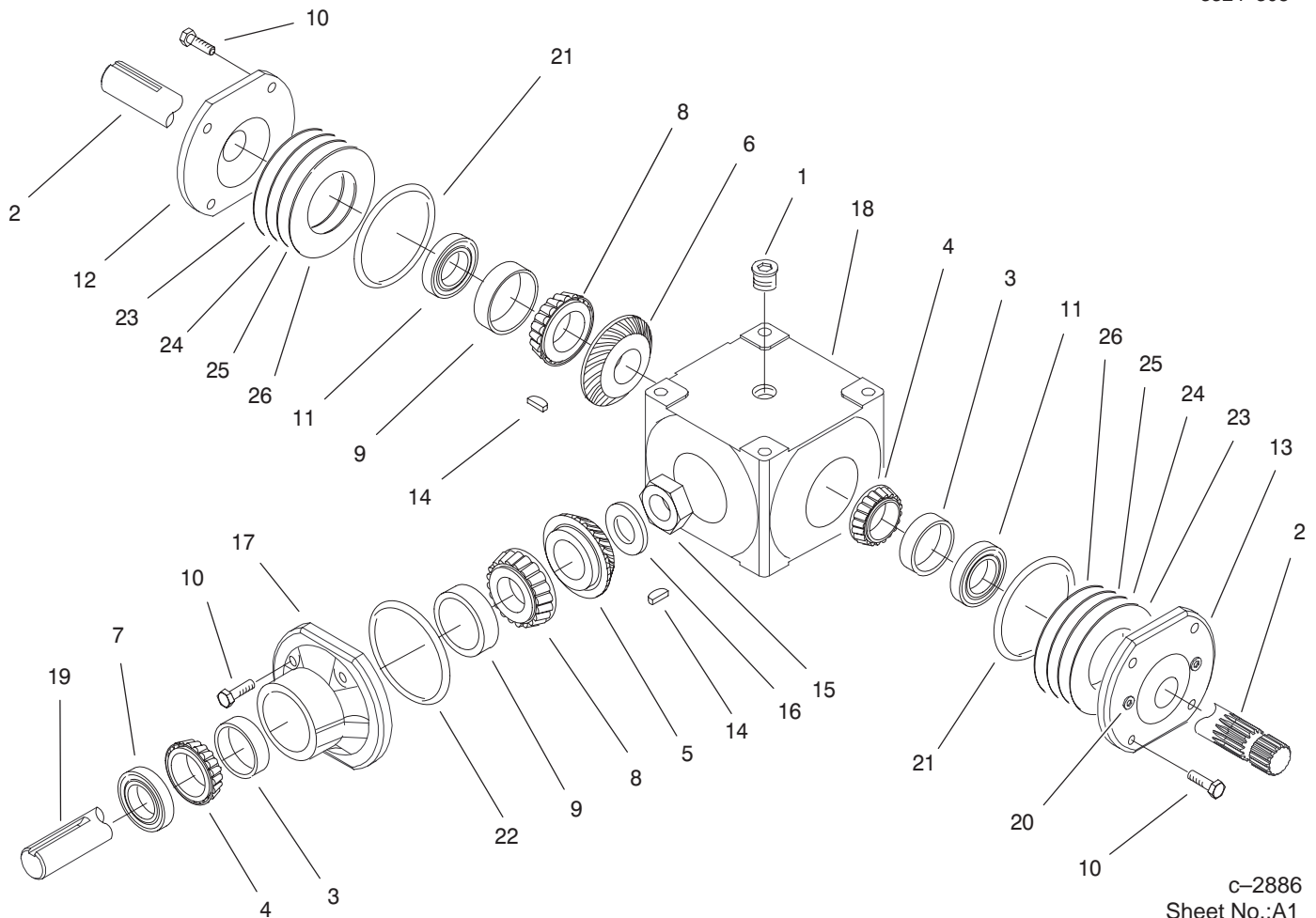

c-2886  
Sheet No.:A1

## Gearcase Assembly No. 100-5842

Ref. No.	Part No.	Qty.	Description
1	100-5812	3	Plug
2	100-5828	1	Shaft – Cross
3	100-4571	2	Cup – Bearing
4	100-4572	2	Cone – Bearing
5	100-5814	1	Gear – Spiral, RH
6	100-5815	1	Gear – Spiral, LH
7	100-4575	1	Seal
8	100-5816	2	Cone – Bearing
9	100-5817	2	Cup – Bearing
10	100-5818	12	Screw-HH
11	100-5819	2	Seal
12	100-5820	1	Cap – End
13	100-5821	1	End Cap w/ Drain Plugs
14	100-5822	2	Key
15	100-5823	1	Nut – Lock
16	100-5824	1	Washer
17	100-5825	1	Housing – Pinion
18	100-5826	1	Case
19	100-5827	1	Shaft – Pinion
20	100-4583	2	Plug
21	100-5847	2	O-Ring
22	100-5848	1	O-Ring
23	100-7757	1	Shim – Green
24	100-7758	1	Shim – Blue

Ref. No.	Part No.	Qty.	Description
25	100-7759	1	Shim – Brown
26	100-7760	1	Shim – Yellow

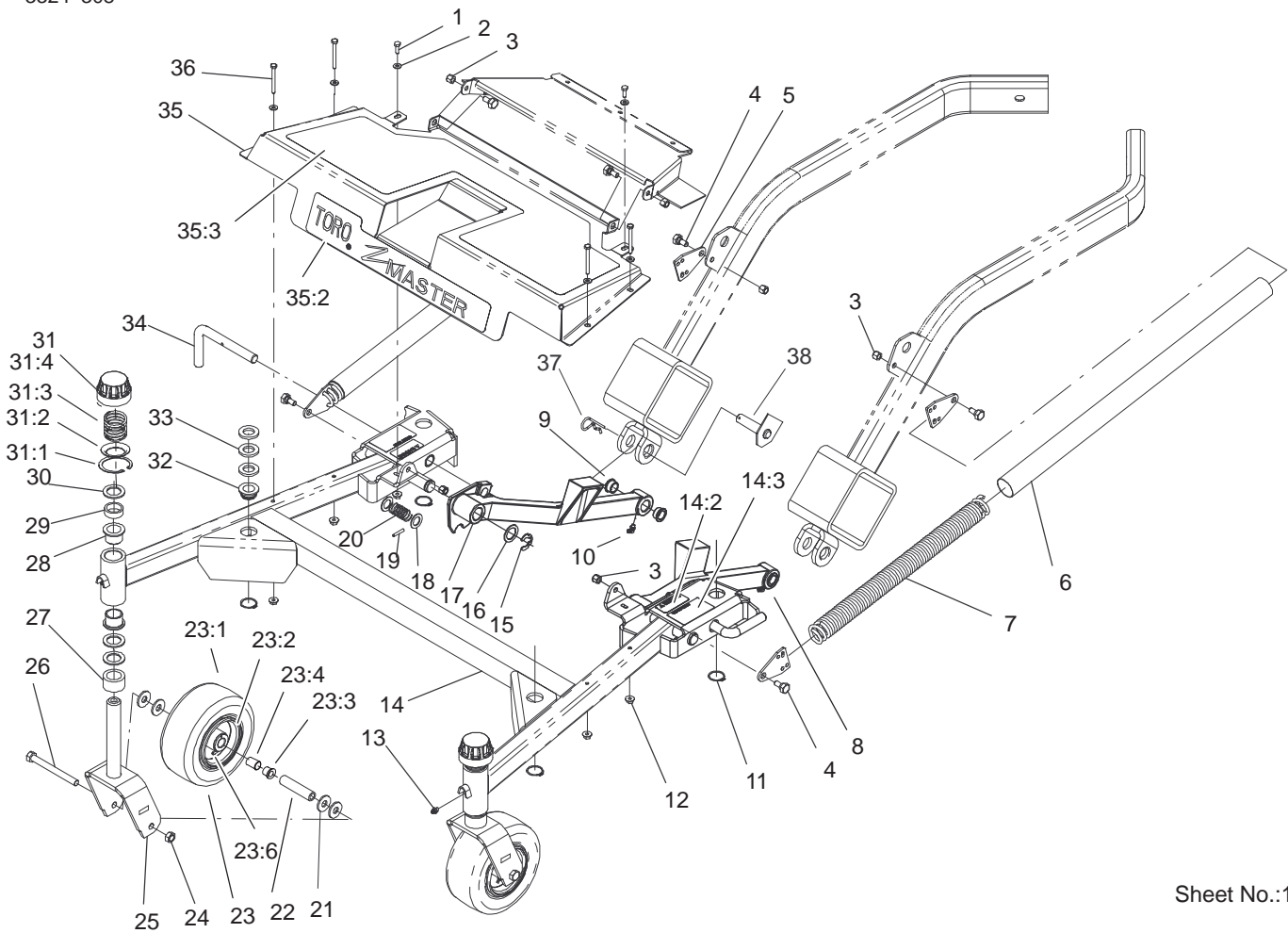

Sheet No.:14

## Carrier Frame Assembly

Ref. No.	Part No.	Qty.	Description
1	321-4	2	Screw-HH
2	3256-22	6	Washer-Flat
3	3296-39	6	Nut-Lock, NI
4	46-3380	6	Bolt-Shoulder
5	94-4750	4	Plate - End, Spring
6	94-9550	2	Cover - Spring
7	94-4664	2	Spring - Extension
8	98-0817-01	1	Casting - Lift Arm, LH
9	27-9080	4	Bearing-Flange
10	302-60	2	Fitting-Lube
11	32120-33	4	Ring-Retaining
12	32128-33	6	Nut-HF
13	302-5	2	Fitting - Lube
14	104-0383	1	Carrier Frame ASM
14:2	93-6696	2	Decal-Loaded, Spring
14:3	104-0381	2	Decal - HOC
15	32151-91	2	Ring-Retaining
16	9202514	2	Washer
17	98-0818-01	1	Casting - Lift Arm, RH
18	9202254	4	Washer
19	32121-79	2	Pin-Roll
20	98-1339	2	Spring - Compression
21	3256-6	8	Washer-Flat
22	68-8980	2	Spanner-Tire
23	99-1268	2	Castor Wheel ASM
23:1	93-9939	1	Tire

Ref. No.	Part No.	Qty.	Description
23:2	100-2348	1	Rim Assembly
23:3	62-5580	2	Bearing-Outside
23:4	62-5570	1	Bearing-Roller
*23:5	100-5832	1	Tube w/ Valve
23:6	302-11	1	Fitting-Lube, 45°
24	32153-5	2	Nut-Lock
25	99-0295-01	2	Castor Fork ASM
26	325-19	2	Screw-HH
27	93-1167	2	Spacer - Castor
28	94-1291	4	Bushing-Special
29	63-0070	2	Spacer
30	3-6781	6	Washer-Thrust
31	92-8862	2	Cap ASM-HOC
31:1	92-5581	1	Ring-Retaining
31:2	92-5583	1	Washer-Cap
31:3	92-5584	1	Spring-Compression
31:4	92-8861	1	Cap-HOC
32	1-513336	4	Bushing - Deck
33	1-513338	12	Washer - Flat
34	100-2389	2	Pin - Pivot
35	100-7774	1	Footrest ASM
35:2	100-7770	1	Decal - Z Master, Toro
35:3	100-7775	1	Pad - Footrest
36	321-15	4	Screw-HH
37	3290-343	2	Pin-Hair
38	94-4755	2	Pivot Pin ASM

\* Not illustrated

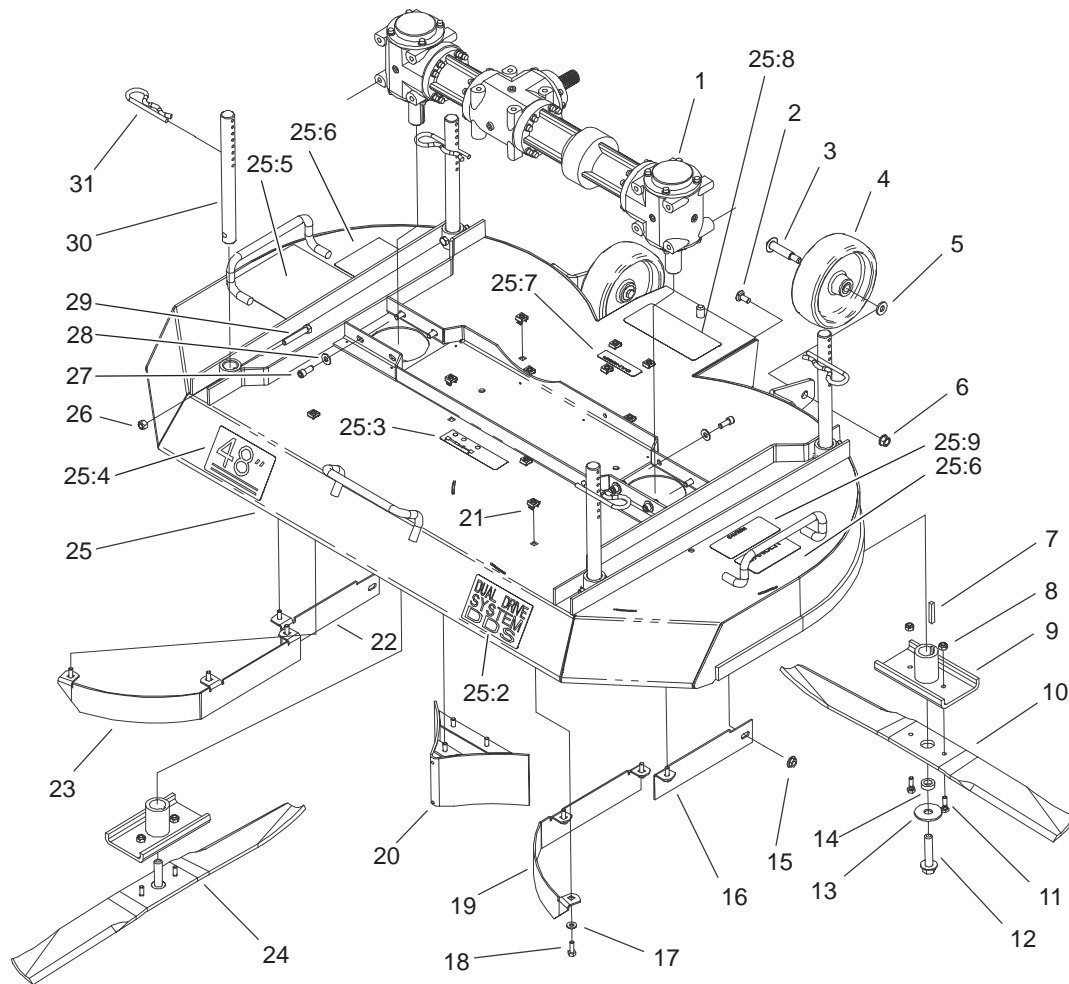

Sheet No.:15

## Deck Assembly

Ref. No.	Part No.	Qty.	Description	Ref. No.	Part No.	Qty.	Description
1	100-2419	1	Gearbox Service ASM	25	104-0380	1	Deck ASM w/ Decals, 48
2	3230-23	2	Screw-CARR	25:2	100-7788	1	Decal - DDS
3	92-1057	2	Bolt-Shoulder	25:3	100-5829	1	Decal - Transmission Fluid
4	95-4102	2	Wheel	25:4	104-0354	1	Decal - 48
5	3256-3	2	Washer-Flat	25:5	98-4358	1	Decal - Danger
6	32128-40	2	Nut-Flange	25:6	98-4369	2	Decal - Warning
7	67-7490	2	Key	25:7	100-3613	1	Decal-Warning
8	3296-16	4	Nut-Lock, NI	25:8	93-7010	1	Decal - Danger
9	98-0810-01	2	Blade Retainer ASM	25:9	98-4363	1	Decal - Blade Bolt Torque
10	99-4942	1	Blade - 25", LH	26	3296-29	4	Nut-Lock, NI
11	99-0283	4	Bolt - Shear	27	104-0356	8	Screw - HSH
12	92-5816	2	Bolt-Blade	28	100-2400	8	Washer - Hard
13	86-1990	2	Washer	29	322-10	4	Screw-HH
14	99-0217	2	Spacer	30	100-2393	4	Pin - Deck
15	32128-13	2	Nut-HF	31	3290-256	4	Pin-Cotter, Hair
16	104-0388-01	1	Bracket - Discharge, LH				
17	3256-22	11	Washer-Flat				
18	321-4	11	Screw-HH				
19	98-3015-01	1	Baffle - LH				
20	100-9655-01	1	Center Baffle ASM				
21	32115-5	11	Nut-Retained				
22	104-0389-01	1	Bracket - Discharge, RH				
23	98-3016-01	1	Baffle - RH				
24	99-4941	1	Blade - 25", RH				

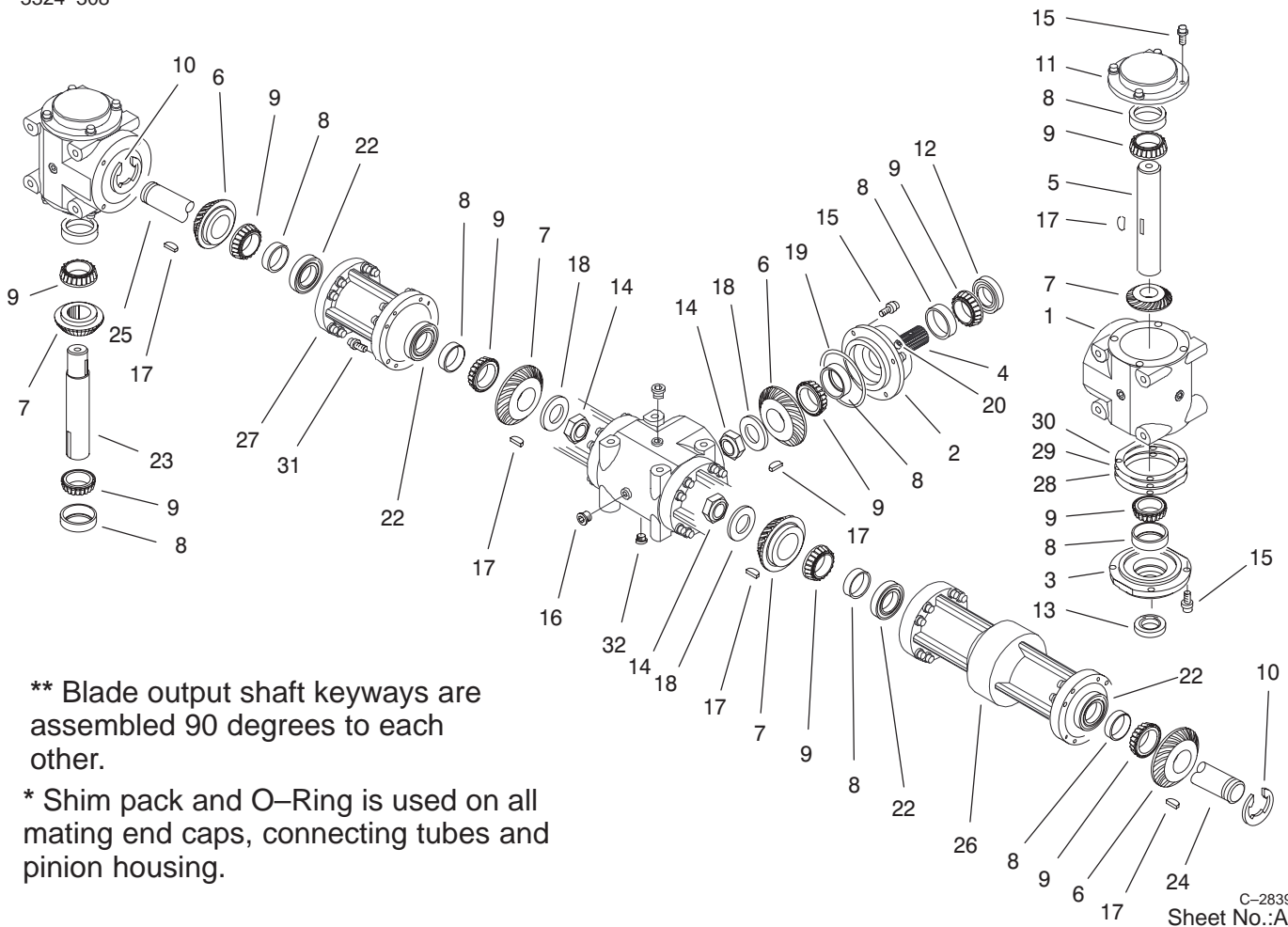

C-2839  
Sheet No.:A2

## Gearbox Assembly 100-2419

Ref. No.	Part No.	Qty.	Description
1	100-4564	3	Case
2	100-4565	1	Housing – Pinion
3	100-4566	2	Cap – End, Open
4	100-7755	1	Pinion Service ASM, Splined
4	100-4567	1	Shaft – Input, Splined
5	100-7754	1	Shaft Service ASM, LH
5	100-4568	1	Shaft – Cross, A/D
6	100-4569	3	Gear – LH, 27 Tooth
7	100-4570	4	Gear – RH, 29 Tooth
8	100-4571	10	Cup – Bearing
9	100-4572	10	Cone – Bearing
10	100-4573	2	Ring – Retaining
11	100-4574	2	Cap – End, Closed
12	100-4575	1	Seal
13	100-4576	2	Seal
14	100-4577	3	Nut – Jam
15	100-4578	20	Screw
16	100-4579	8	Plug
17	100-4580	7	Key – Woodruff
18	100-4581	3	Washer
19	100-4582	9	O-Ring
20	100-4583	1	Plug
*21	100-4584	1	Cover – Transparent
22	100-4585	4	Seal
23	100-4586	1	Shaft – Cross, B/D

Ref. No.	Part No.	Qty.	Description
23	100-7753	1	Shaft Service ASM, RH
24	100-4587	1	Shaft – Connecting, Long
25	100-4588	1	Shaft – Connecting, Short
26	100-4589	1	Flange – Connecting, Long
27	100-4590	1	Flange – Connecting, Short
28	100-4591	1	Shim – Brown
29	100-4592	1	Shim – Blue
30	100-4593	1	Shim – Green
31	100-4594	32	Screw
32	100-4595	1	Plug – Magnetic

\* Not illustrated



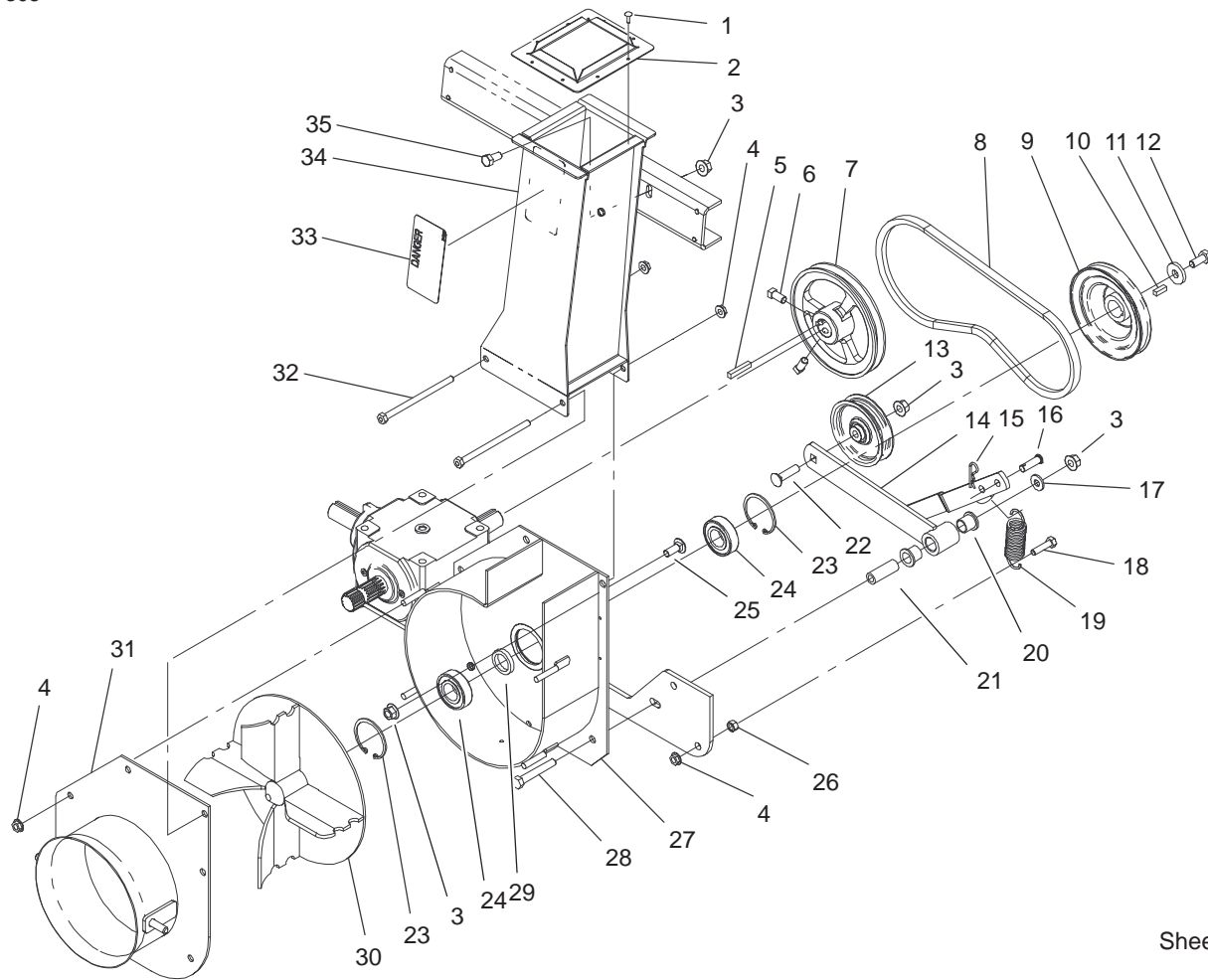

Sheet No.:17

## Blower Assembly

Ref. No.	Part No.	Qty.	Description
1	3290-271	6	Rivet-Pop
2	100-4558-03	1	Flange-Chute
3	32128-21	4	Nut-HF
4	32128-25	7	Nut-Flange
5	67-7490	1	Key
6	3242-4	2	Screw-Set, SQH
7	98-4392	1	Pulley - Gearbox
8	98-4393	1	V-Belt
9	99-0287	1	Pulley - Impeller
10	20-9540	1	Key
11	65-8680	1	Washer - Thrust, Plain
12	323-5	1	Screw-HH
13	56-4920	1	Idler Pulley
14	95-6437-03	1	Idler Arm ASM
15	3290-467	1	Pin-Hair
16	283-2	1	Pin-Clevis
17	3256-3	1	Washer-Flat
18	322-6	1	Screw-HH
19	67-1440	1	Spring-Extension
20	256-90	2	Bushing-Flange
21	95-6448	1	Spacer
22	3231-4	1	Screw-CARR
23	32120-8	2	Ring-Snap
24	251-82	2	Bearing-Ball
25	3231-2	1	Screw-CARR
26	3217-6	1	Nut-Hex

Ref. No.	Part No.	Qty.	Description
27	99-0290-03	1	Housing ASM
28	323-12	1	Screw-HH
29	95-6427	1	Spacer - Bearing
30	99-0296-03	1	Impeller ASM
31	100-7795-03	1	Cover ASM
32	322-29	2	Screw-HH
33	93-7010	1	Decal - Danger
34	95-4345-03	1	Impeller Chute ASM
35	323-4	1	Screw-HH

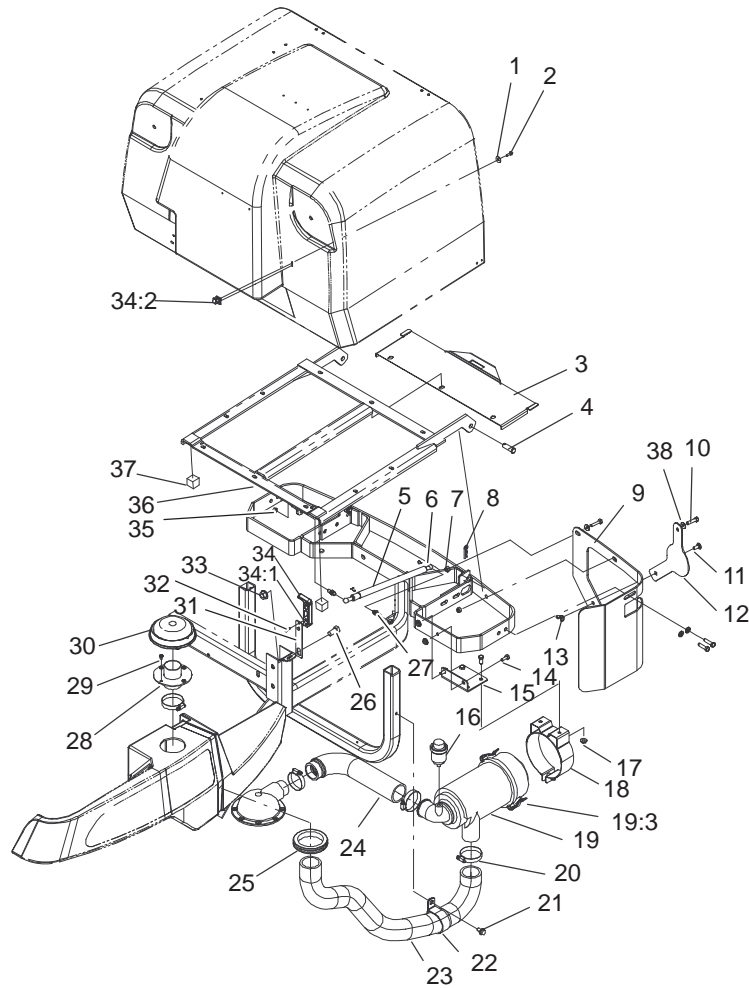

Sheet No.:18

## Air Cleaner and Bagger Frame Assembly

Ref. No.	Part No.	Qty.	Description	Ref. No.	Part No.	Qty.	Description
1	3256-61	1	Washer-Flat	23	100-2405	1	Hose
2	3290-134	1	Screw-Ind Hex	24	100-2406	1	Hose
3	100-7773-03	1	Plate - Latch	25	240-8	1	Rubber Grommet
4	283-68	2	Clevis Pin	26	325-4	1	Screw-HH
5	98-3043	1	Gas Spring	27	88-6770	2	Stud-Ball
6	98-3044	2	Safety Clip	28	100-2411-03	1	Flanged Connector ASM
7	3296-29	2	Nut-Lock, NI	29	32104-111	4	Screw
8	3290-355	2	Pin-Hair	◇30	25-324-02-S	1	Hood
9	104-0355-03	1	Guard - Filter, Air	31	98-3032	1	Bracket - Latch
10	322-6	2	Screw-HH	32	3290-359	2	Screw-HWH
11	3230-23	1	Screw-CARR	33	32128-23	1	Nut-HF
12	104-0364-03	1	Plate - Cover	34	94-5626	1	Latch - Draw, Flexible
13	32103-29	1	Nut-Wing	34:1	100-5806	1	Handle - Latch
14	322-3	4	Screw-HH	34:2	100-5807	1	Keeper - Latch
15	100-2412-03	1	Bracket	35	32152-1	2	Nut-Lock, NI
16	99-4664	1	Filter Minder	36	95-6418-03	1	Frame ASM
17	32128-13	4	Nut-HF	37	104-0367	2	Cushion
◇18	25-126-02-S	1	Bracket - A/C	38	3256-23	2	Washer-Flat
◇19	25-048-07-S	1	Air Cleaner				
*19:1	100-4557	1	Filter - Safety				
*19:2	100-4556	1	Element A/C				
19:3	99-3174	2	Clip-Cleaner, Air				
*19:4	99-3175	1	Valve-Ejector, Dust				
20	2412-130	4	Hose Clamp				
21	32144-14	1	Screw-HWH				
22	2412-102	1	R-Clamp				

◇ Obtain parts from Kohler

\* Not illustrated

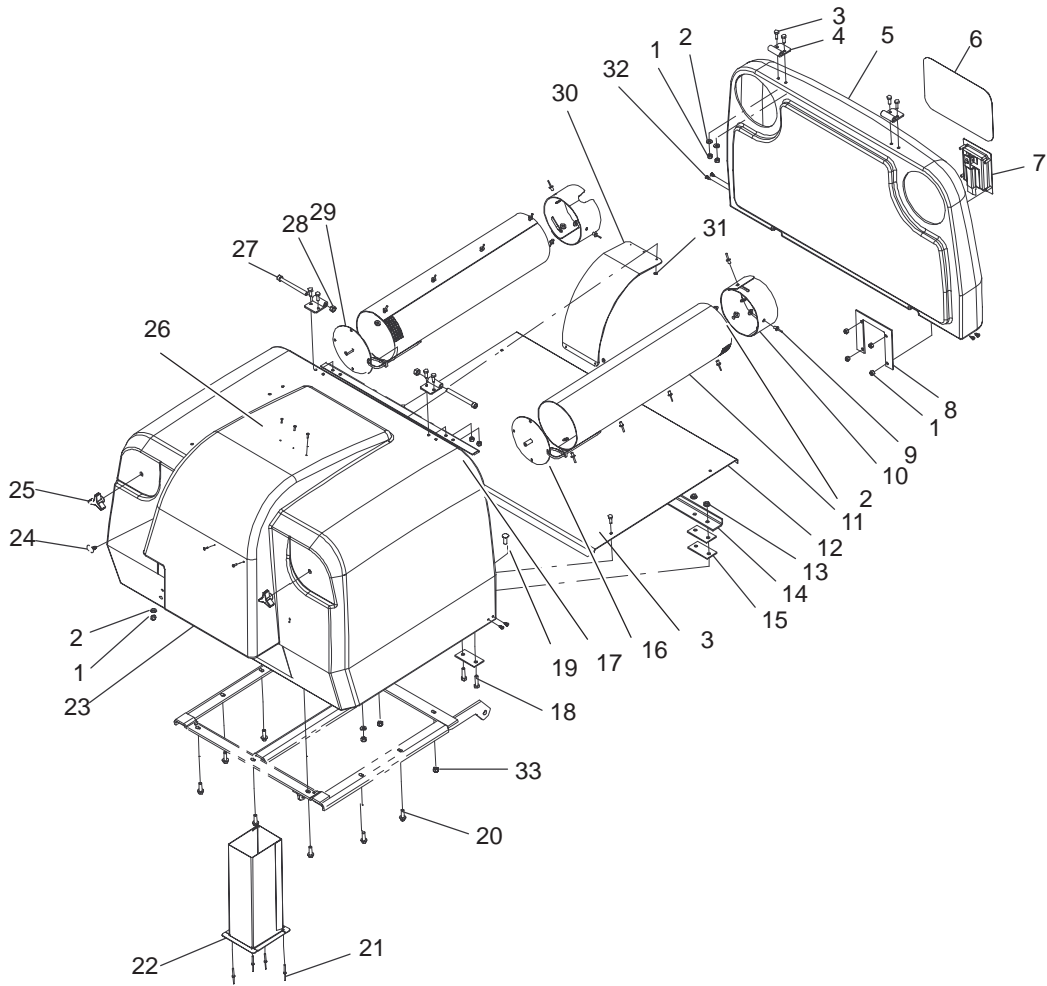

Sheet No.:19

## Bagger Assembly

Ref. No.	Part No.	Qty.	Description
1	3296-42	14	Nut-Lock
2	3256-22	20	Washer-Flat
3	321-4	10	Screw-HH
4	98-3027-03	4	Hinge
5	100-9617	1	Cover - Bin
6	67-7310	1	Decal - Toro Logo, 7"
7	100-9631	1	Lever - Latch
8	100-9632-03	1	Plate - Latch
9	3290-412	14	Rivet
10	100-5845	2	Ring - Support
11	95-6441	2	Screen
12	100-4550-03	1	Floor - Hopper
13	32128-25	11	Nut-Flange
14	98-0849-03	1	Flange - Bin
15	98-3004	6	Spacer
16	3290-378	8	Tie-Cable
17	98-3036-03	1	Angle - Bin
18	322-6	4	Screw-HH
19	3230-3	3	Screw-CARR
20	3234-17	7	Screw-HHF
21	98-7310	4	Rivet
22	95-6482-03	1	Chute ASM
23	95-6422	1	Bin - Grass
24	104-0395	1	Plug - Plastic
25	233-52	2	Knob
26	3269-17	5	Pop Rivet

Ref. No.	Part No.	Qty.	Description
27	3274-102	2	Screw-HSH
28	3296-59	2	Nut-Lock, NI
29	95-6444-03	2	Plate ASM
30	100-4552	1	Plate - Wear
31	3256-12	5	Washer-Flat
32	104-0397	8	Plug - Plastic
33	32149-1	3	Nut-keps

# Electric Schematic

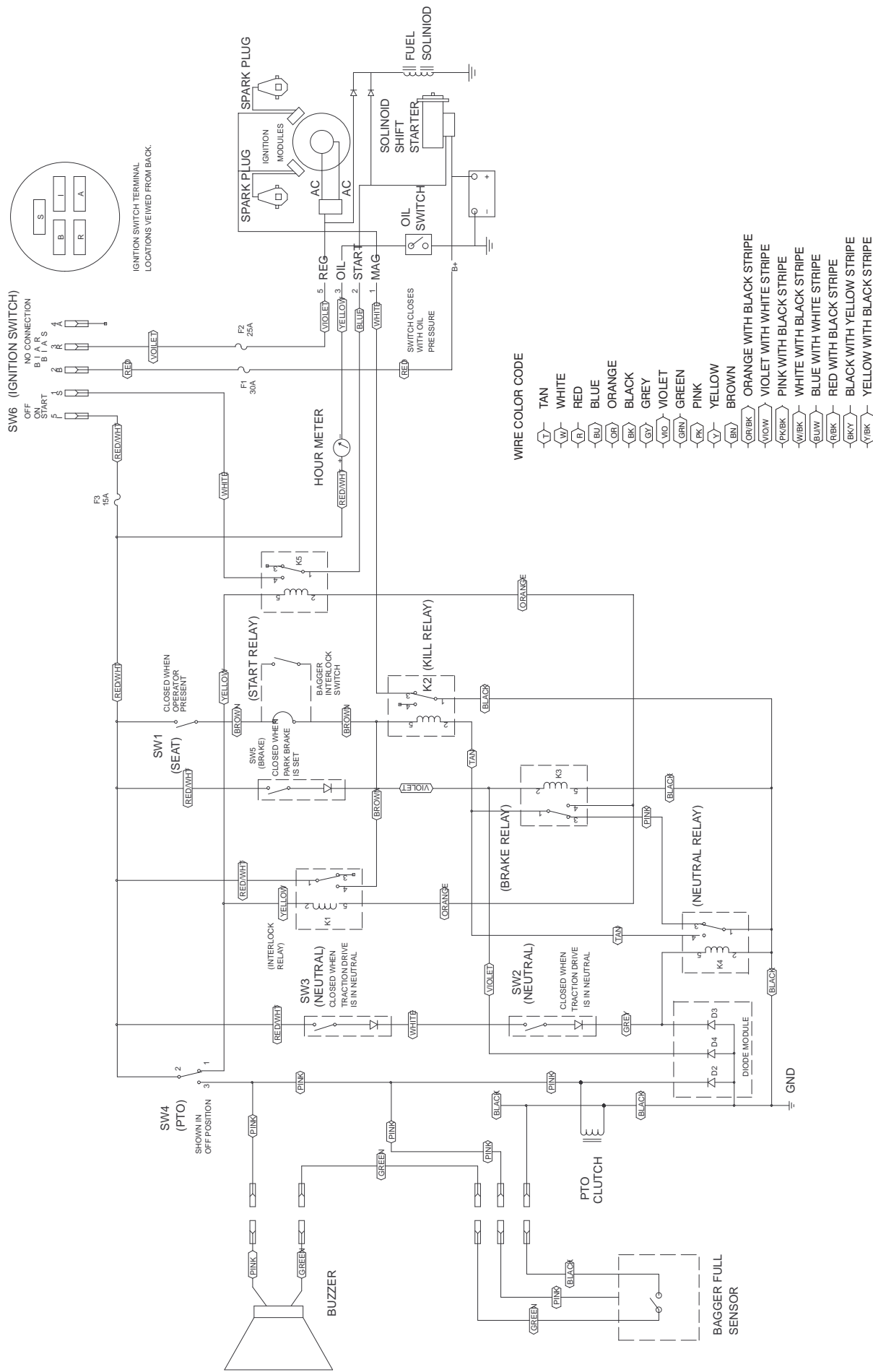

# Hydraulic Schematic

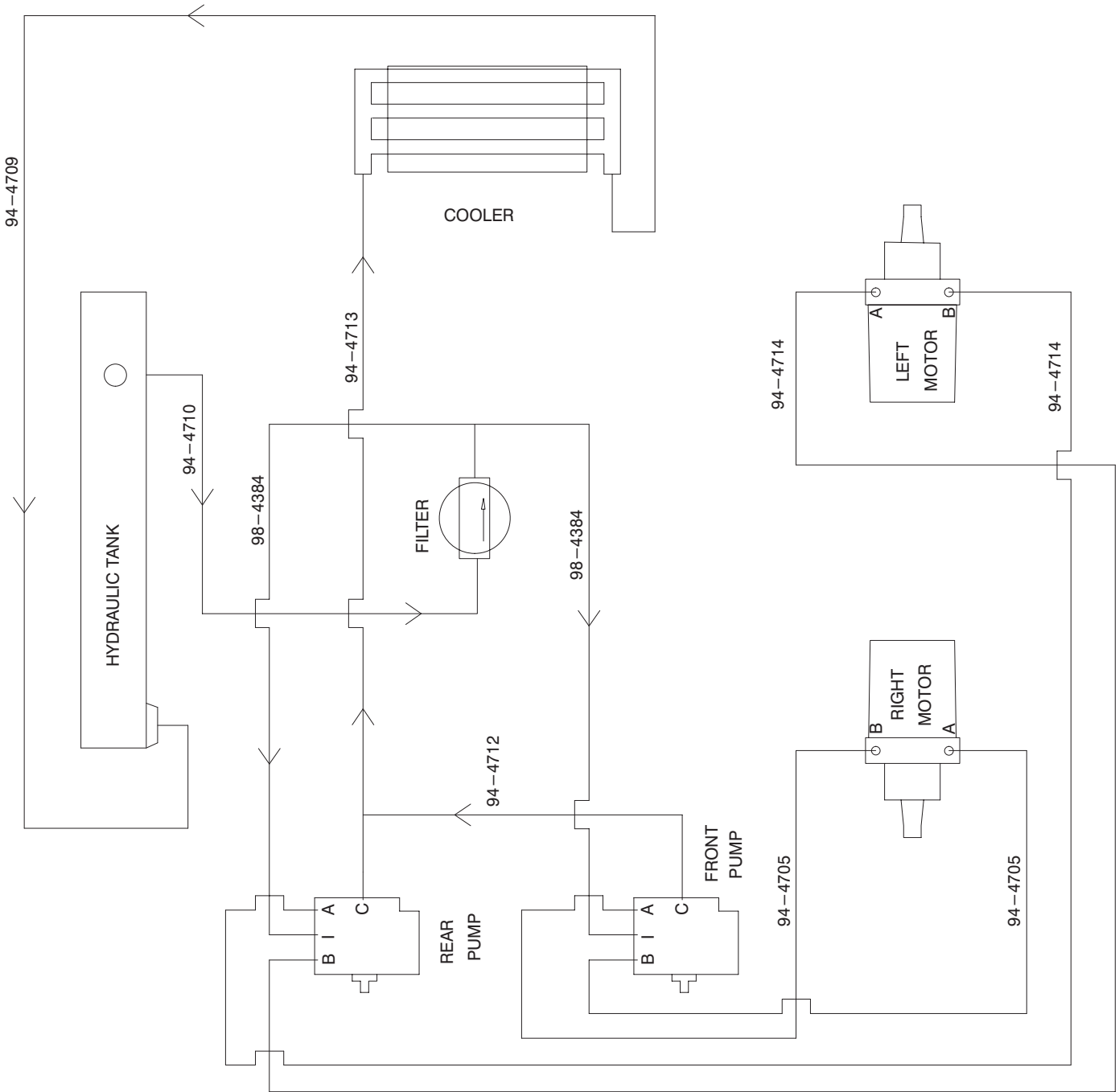



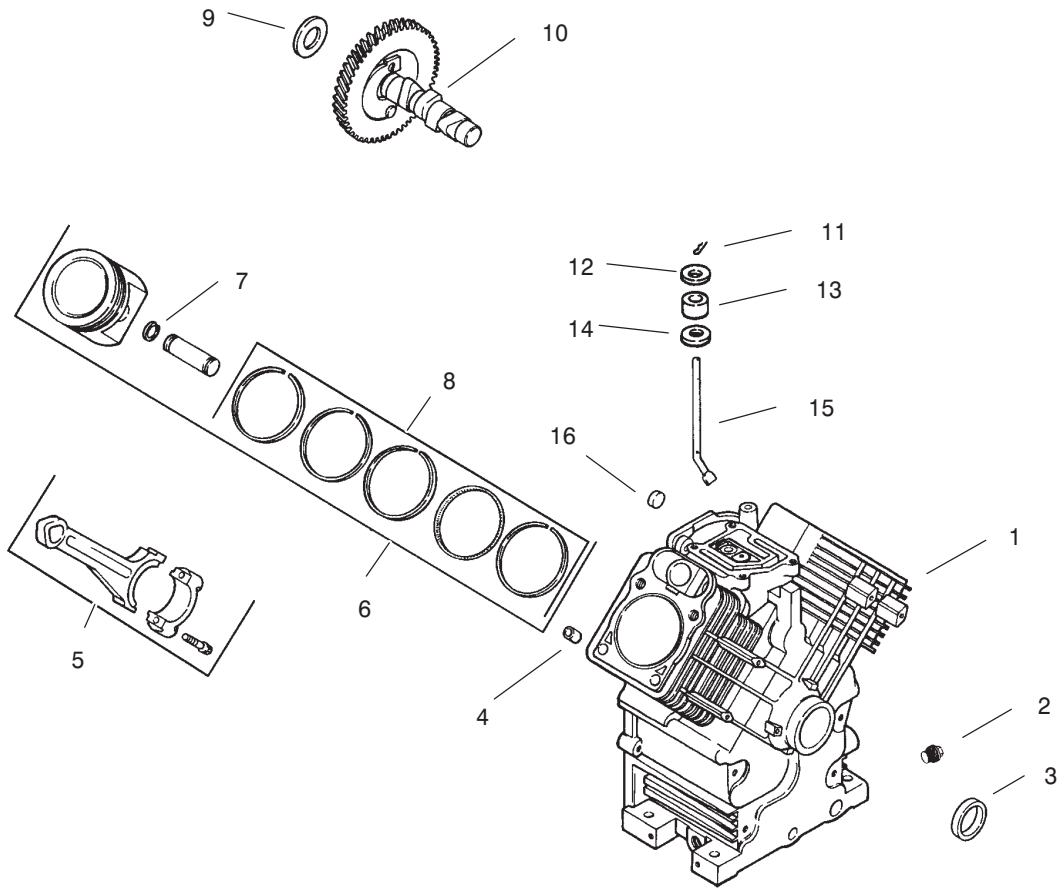

## Crankcase (Kohler CH20S PS64644)

Ref. No.	Description	Part No.
1	Crankcase (USE: Miniblock 24 782 01)	
2	Plug, hex. hd. 3/8 N.P.T.F.(2)	X -75-10-S
3	Seal, oil front	24 032 01-S
4	Pin, dowel locating (6)	12 380 17-S
5	Connecting Rod (Std.) (2)	24 067 13-S
	Connecting Rod (.25) (2)	24 067 14-S
6	Piston w/Ring Set (Std.) (2)	
	(Includes 7,8)	24 874 01-S
	Piston w/Ring Set (.25) (2)	24 874 02-S
	Piston w/Ring Set (.50) (2)	24 874 03-S
	Piston w/Ring Set (.08) (2)	24 874 14-S
7	Retainer, piston pin (4)	24 018 01-S
8	Ring Set (Std.) (2)	24 108 01-S
	Ring Set (.25) (2)	24 108 02-S
	Ring Set (.50) (2)	24 108 03-S
9	Shim, camshaft (AR)	12 422 09-S
	Shim, camshaft (AR)	12 422 13-S
	Shim, camshaft (AR)	12 422 07-S
	Shim, camshaft (AR)	12 422 08-S
	Shim, camshaft	12 422 10-S
	Shim, camshaft (AR)	12 422 11-S
	Shim, camshaft (AR)	12 422 12-S
10	Camshaft	24 012 10-S
11	Pin, hitch	12 380 04-S
12	Washer, plain 6 mm	M-631005-S

Ref. No.	Description	Part No.
13	Seal, governor cross shaft	12 032 01-S
14	Washer, plain 1/4	X-25-102-S
15	Shaft, governor cross	24 144 01-S
16	Plug, cup	52 139 09-S
	NOT ILLUSTRATED	
	Decal	24 113 56-S

Obtain Parts from Kohler

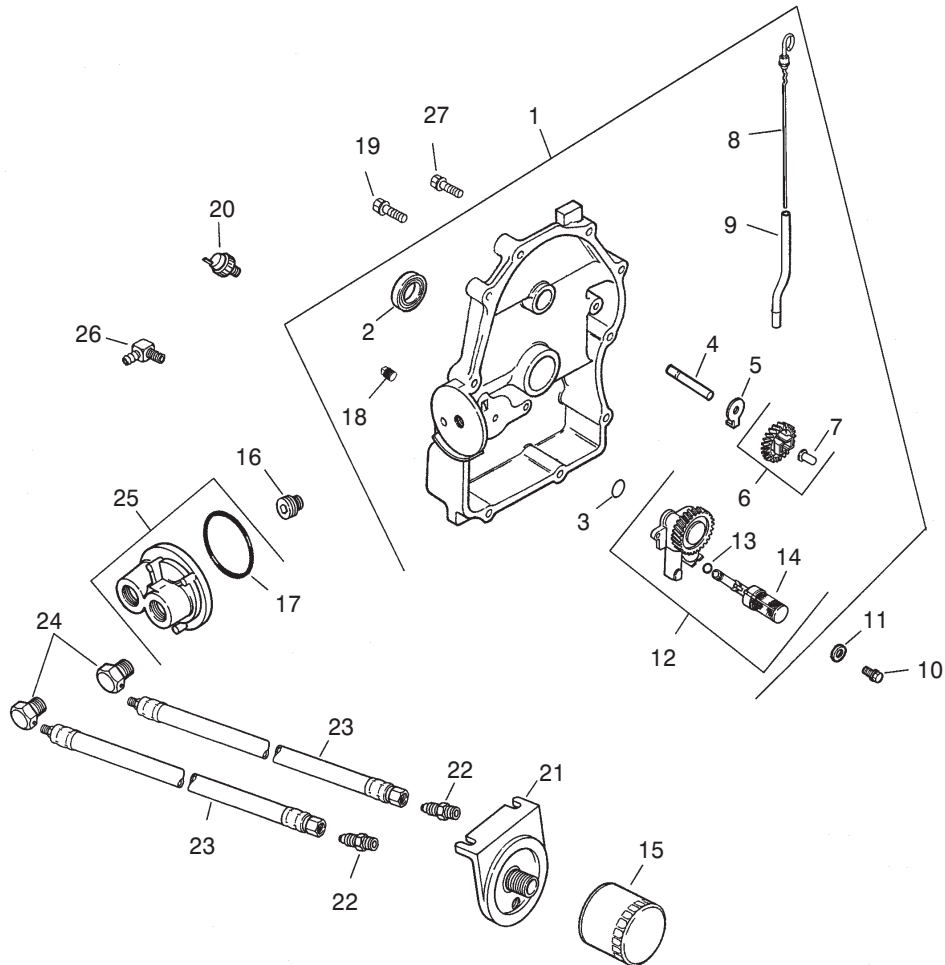

## Oil Pan / Lubrication (Kohler CH20S PS64644)

Ref. No.	Description	Part No.	Ref. No.	Description	Part No.
1	Kit, closure plate (incl. 2-9 & 13,14 & 18 )	24 009 82-S	22	Nipple, hex (2)	52 136 02-S
2	Seal, oil (PTO end)	52 032 08-S	23	Hose, oil (2)	52 326 11-S
3	O-Ring	24 153 08-S	24	Reducer, fitting (2)	24 294 04-S
4	Shaft, governor gear	12 144 02-S	25	Adapter, oil filter (incl. 22) (2)	24 029 02-S
5	Tab, locking	52 448 02-S	26	Connector	25 155 02-S
6	Kit, governor gear w/pin (Includes 7)	24 043 12-S	27	Screw, hex. flange M8x1.25x45	24 086 17-S
7	Pin, governor regulating	12 380 01-S		NOT ILLUSTRATED	
8	Dipstick	24 038 06-S		Decal, oil cooler	24 113 25-S
9	Tube, dipstick	24 123 08-S			
10	Screw, hex. flange M6x1.0x25 (2)	M-645025-S			
11	Washer, plain 6 mm (2)	M-631005-S			
12	Oil pump assembly (Includes 13-14)	24 393 10-S			
13	O-Ring, oil pick-up	24 153 01-S			
14	Pick-up, oil	24 381 04-S			
15	Filter, oil	52 050 02-S			
16	Nipple, oil filter	24 136 01-S			
17	O-Ring	24 153 13-S			
18	Plug, allen hd. 1/8 pipe	X-75-23-S			
19	Screw, hex. flange M8x1.25x45 (9)	24 086 16-S			
20	Switch, oil pressure	24 099 03-S			
21	Adapter, remote oil filter	25 029 01-S			

Obtain Parts from Kohler

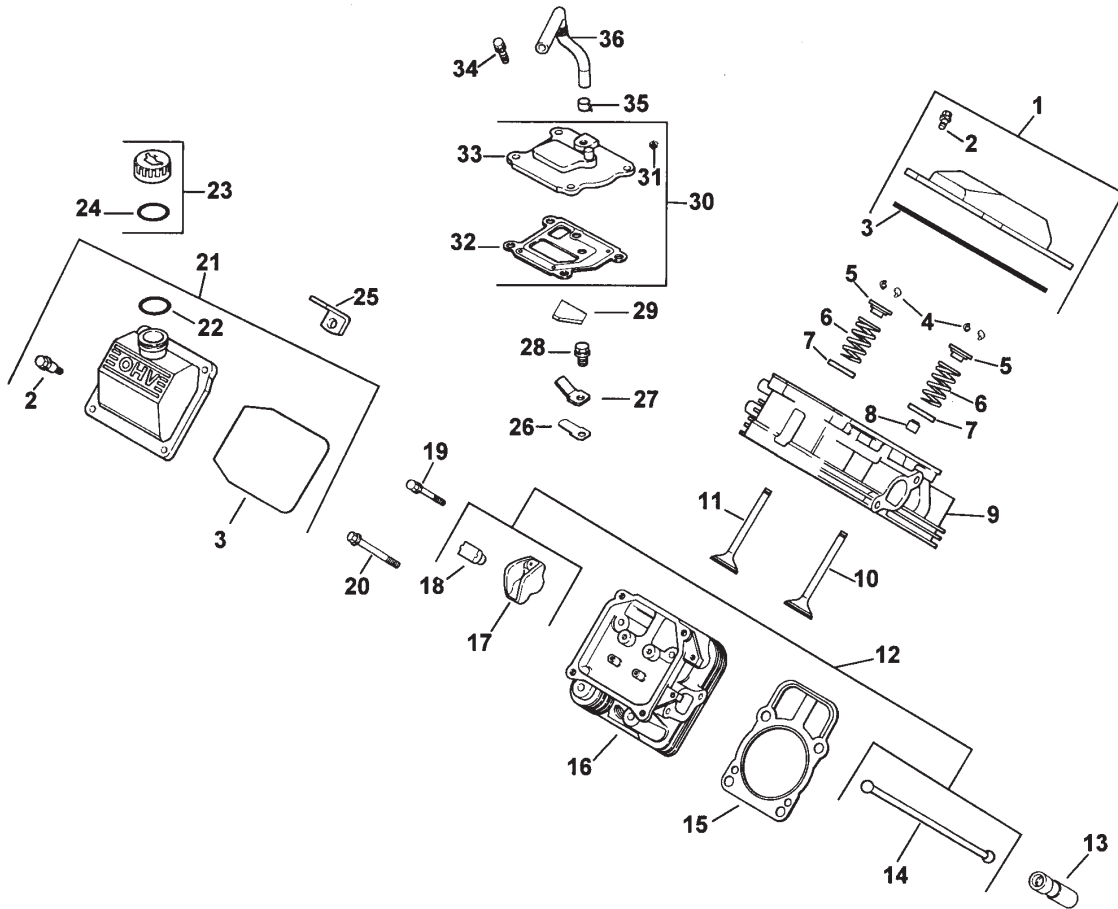

## Head / Valve / Breather (Kohler CH20S PS64644)

Ref. No.	Description	Part No.	Ref. No.	Description	Part No.
1	Kit, valve cover – plain (Includes 2,3)	24 755 74-S	20	Screw, M10x1.5x90 (8)	12 086 16-S
2	Screw, shoulder (4)	24 086 32-S	21	Kit, valve cover – oil fill (Includes 2,3,22)	24 755 75-S
3	O-Ring, valve cover	24 153 16-S	22	O-Ring	24 153 09-S
4	Kit, retainer (4)	12 755 03-S	23	Kit, oil fill cap (Includes 24)	24 755 46-S
5	Cap, valve spring (4)	12 173 01-S	24	O-Ring, oil fill cap	12 153 03-S
6	Spring, valve (4)	24 089 02-S	25	Strap, lifting	24 445 01-S
7	Retainer, spring (4)	235011-S	26	Reed, breather	24 402 03-S
8	Seal, valve stem (2)	24 032 05-S	27	Retainer, breather reed	12 018 01-S
9	Head assembly, #1 cylinder	24 318 09-S	28	Screw, hex. flange M5x0.8x10	M-545010-S
10	Valve, intake ( Std.) (2)	24 017 01-S	29	Filter, breather	24 050 01-S
	Valve, intake (.25) (2)	24 017 02-S	30	Kit, breather (Includes 31-33)	24 033 01-S
11	Valve, exhaust (Std.) (2)	24 016 01-S	31	Plug, allen head 1/8 pipe	X-75-23-S
	Valve, exhaust (.25) (2)	24 016 02-S	32	Gasket, breather	24 041 23-S
12	Kit, valve train (Includes 14,17,18)	24 755 66-S	33	Cover, breather	24 096 58-S
13	Lifter, valve (4)	12 351 01-S	34	Screw, hex. flange M6x1.0x20 (4)	M-645020-S
14	Rod, push (4)	24 411 05-S	35	Clamp, breather	X-426-9-S
15	Gasket, cylinder head (2)	24 041 16-S	36	Hose, breather	24 326 26-S
16	Head assembly, #2 cylinder	24 318 08-S			
17	Arm, rocker (4)	25 186 01-S			
18	Pivot, rocker arm (4)	24 599 01-S			
19	Screw, hex. flange M6x1.0x34 (4)	M-640034-S			

Obtain Parts from Kohler

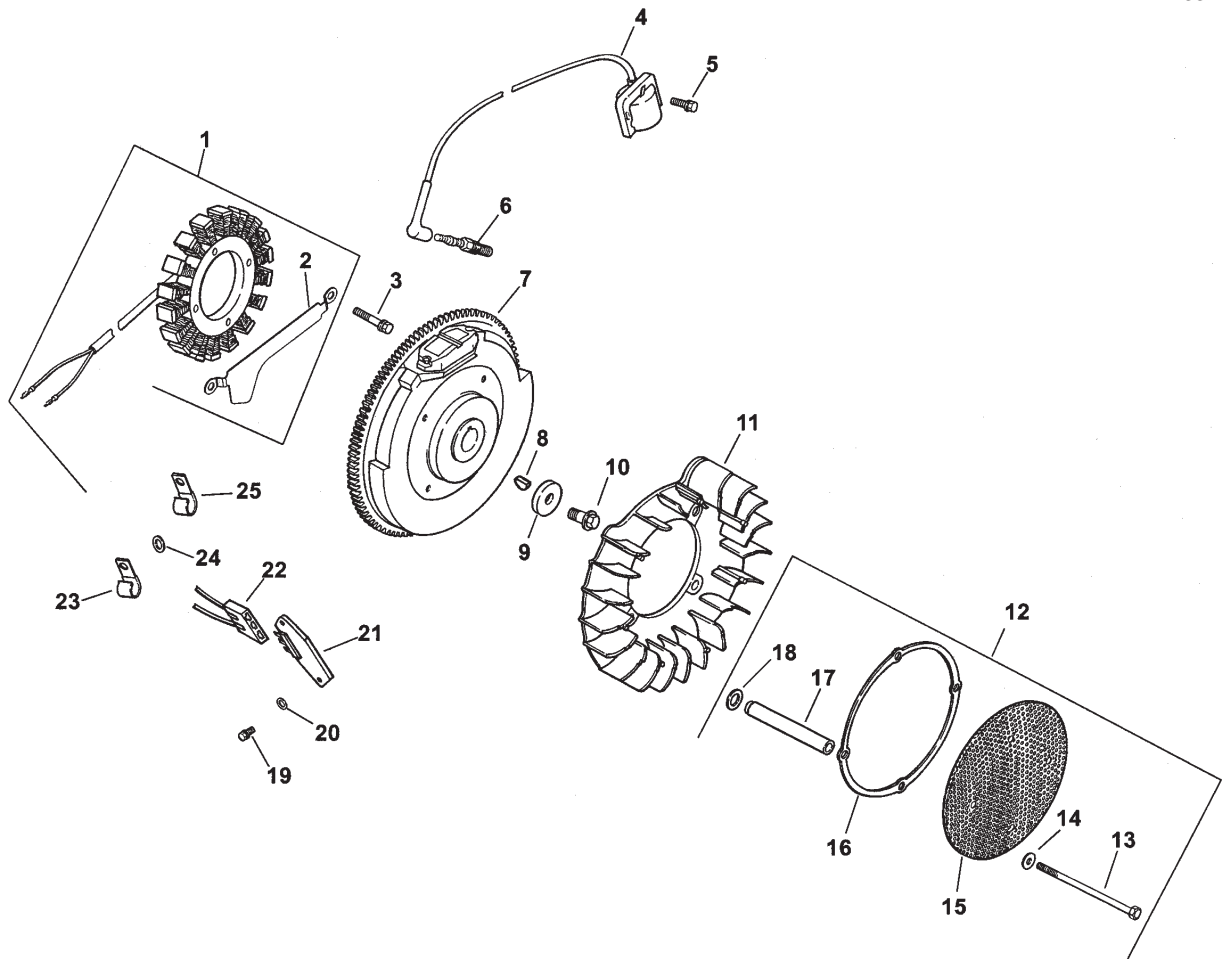

## Ignition / Electrical (Kohler CH20S PS64644)

Ref. No.	Description	Part No.	Ref. No.	Description	Part No.
1	Kit, 15 amp stator (Incl. 2 )	54 755 09-S	16	Ring, support	24 141 06-S
2	Bracket, stator wire	24 126 71-S	17	Spacer, grass screen (4)	24 112 14-S
3	Screw, hex. cap M5x0.8x25 (2)	M-548025-S	18	Washer, spring 10 mm (4)	24 468 11-S
4	Module, ignition (2)	24 584 01-S	19	Screw, phillips hd. 11-16x7/8 (2)	24 086 18-S
5	Screw, hex. flange M5x0.8x20 (4)	M-545020-S	20	Washer, plain 3/16 (2)	X-25-92-S
6	Spark Plug (2)	12 132 06-S	21	Rectifier-regulator 15 amp	25 403 03-S
7	Flywheel	24 025 01-S	22	Connector	236602-S
8	Key	X-42-15-S	23	Clip, cable	235173-S
9	Washer, plain 3/8.	12 468 03-S	24	Washer, plain 1/4	X-25-63-S
10	Screw, hex. flange M10x1.5x46	12 086 14-S	25	Clip, cable	48 154 02-S
11	Fan	24 157 03-S		NOT ILLUSTRATED	
12	Kit, chopper screen (incl. 13-18)	24 755 79-S		Harness, wiring	24 176 40-S
13	Screw, hex. head. M6x1.0x100 (4)	M-603100-S		Lead, black (5"-12 gauge - insulated grip barrel eyelet terminals)	24 518 12-S
14	Washer, plain 1/4" (4)	X-25-53-S		Screw, set (adjusts grass scraper blade)	25 086 43-S
15	Screen, grass	24 162 25-S		Tie, cable (2)	25 454 03-S

Obtain Parts from Kohler



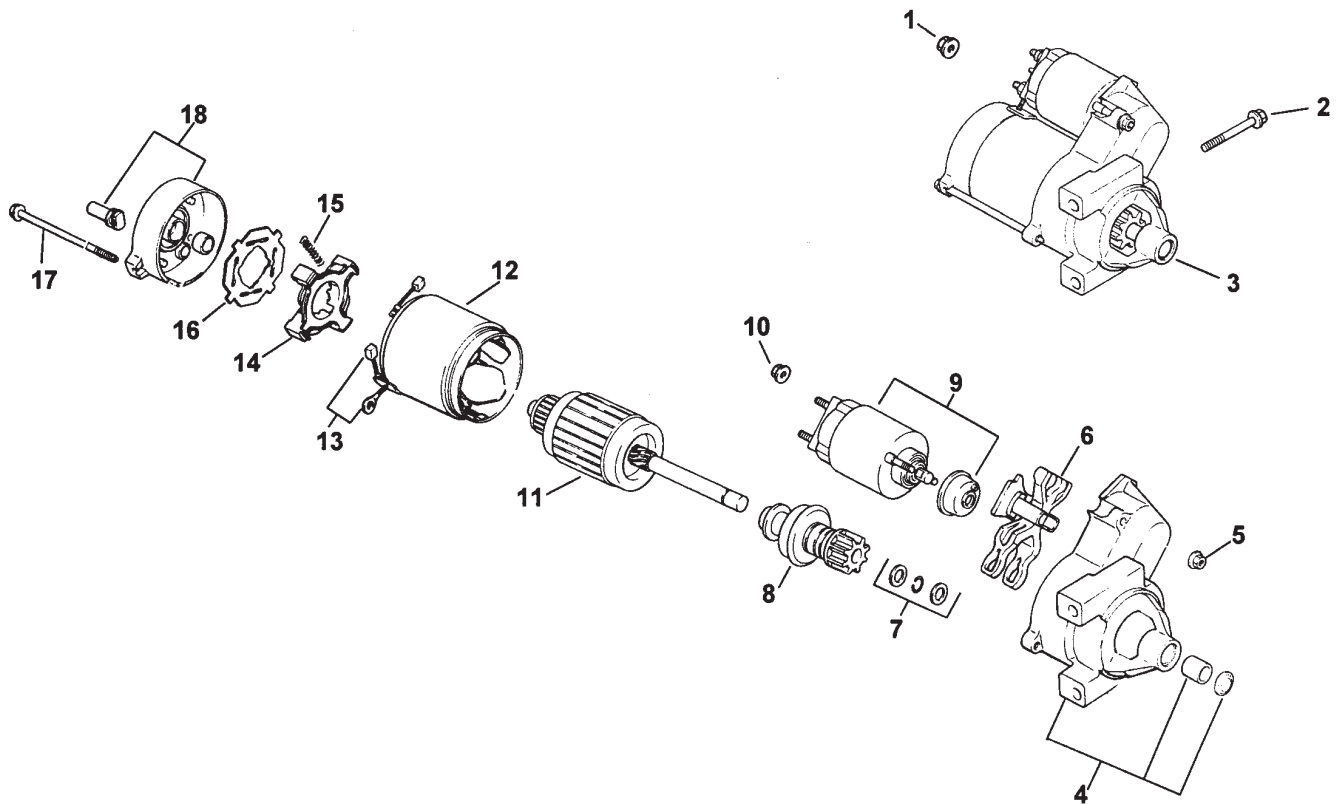

## Starting System (Kohler CH20S PS64644)

Ref. No.	Description	Part No.	Ref. No.	Description	Part No.
1	Nut, hex flange M8x1.25	M-841080-S			
2	Screw, hex. flange M8x1.25x80 (2)	M-839080-S			
3	Starter, solenoid shift (Includes 4-18)	24 098 01-S			
4	Drive, end cap	24 081 04-S			
5	Nut, starter (2)	52 100 10-S			
6	Lever, starter drive	12 090 10-S			
7	Kit, starter repair	24 755 84-S			
8	Drive, pinion	12 239 01-S			
9	Solenoid	52 435 02-S			
10	Nut, starter	52 100 09-S			
11	Armature, starter	12 170 04-S			
12	Frame	12 471 01-S			
13	Kit, brush & spring (Includes 15)	52 221 01-S			
14	Holder, brush	52 323 03-S			
15	Spring, brush (4)	52 089 09-S			
16	Insulator	52 168 01-S			
17	Bolt, thru (2)	52 211 05-S			
18	Commutator, end cap	24 301 01-S			

Obtain Parts from Kohler

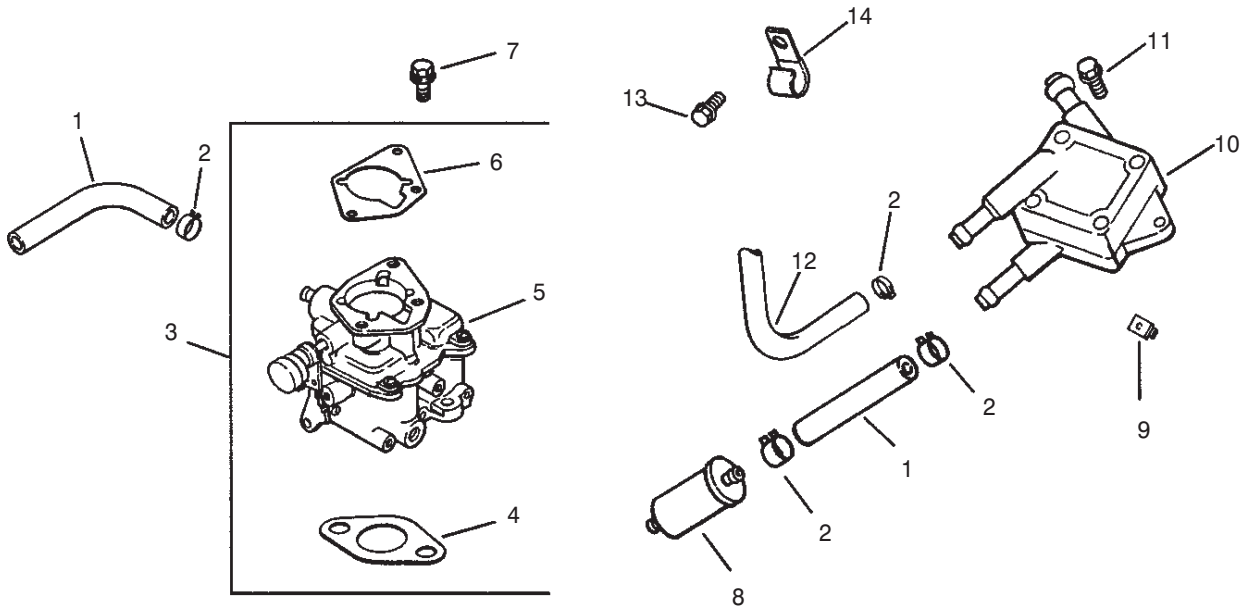

## Fuel System (Kohler CH20S PS64644)

Ref. No.	Description	Part No.
1	Line, fuel 9" (2)	25 353 10-S
2	Clamp, hose (6)	X-426-9-S
3	Kit, carburetor w/gasket (Includes 4-6)	24 853 75-S
4	Gasket, air cleaner	24 041 06-S
5	Carburetor assembly (For information only not available seperately) (Includes 24 757 01-S, 24 757 02-S, 24 757 03-S, & 24 757 07-S,	24 053 75
6	Gasket, carburetor	24 041 17-S
7	Screw, hex. flange M6x1.0x30 (2)	M-651030-S
8	Filter, fuel	24 050 02-S
9	Nut, plastic (2)	24 100 01-S
10	Pump, fuel - pulse	24 393 16-S
11	Screw, hex. cap M6x1.7x 18 (2)	24 086 12-S
12	Line, fuel 15-1/2"	24 353 02-S
13	Screw, hex. flange M6x1.0x10	M-650012-S
14	Clip, cable	24 154 03-S

Ref. No.	Description	Part No.
	NOT ILLUSTRATED	
	Kit, solenoid (Includes solenoid seat 24 521 01-S, O-Ring 24 153 04-S, O-Ring 24 153 05-S, O-Ring 24 153 06-S, solenoid screw 24 086 07-S, & solenoid 24 435 01-S	24 757 01-S
	Kit, float	24 757 02-S
	Kit, carburetor repair (Includes inlet needle valve clip 24 154 01-S, inlet needle valve 24 462 01-S, carburetor body screw 24 086 09-S, carburetor body gasket 24 041 09-S, slow O-Ring 24 153 02-S, O-Ring 24 153 04-S, O-Ring 24 153 05-S, O-Ring 24 153 06-S, idle needle 24 368 01-S, idle needle spring 24 089 11-S,)	24 757 03-S

Obtain Parts from Kohler

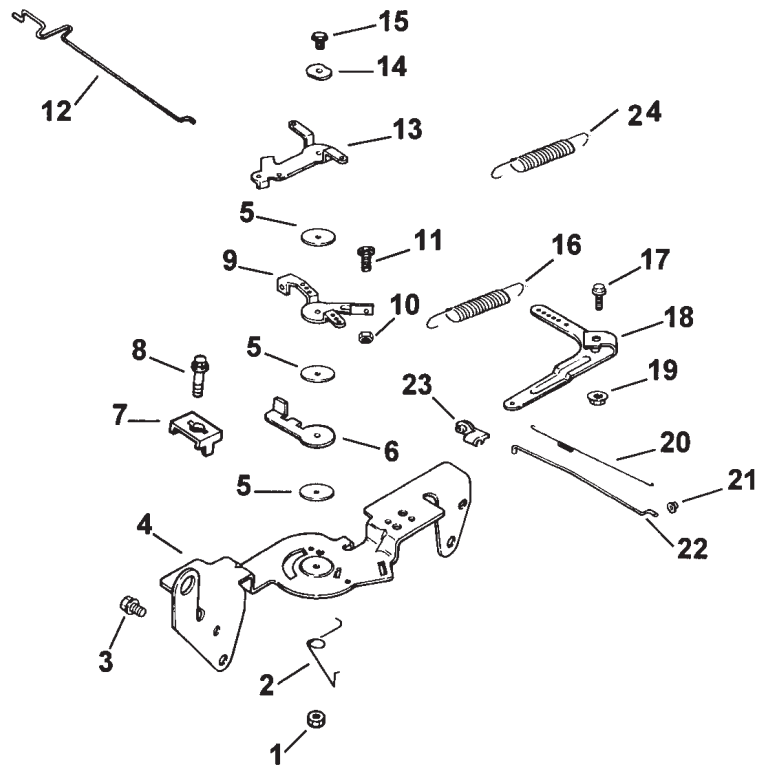

## Engine Controls (Kohler CH20S PS64644)

Ref. No.	Description	Part No.	Ref. No.	Description	Part No.
1	Nut, hex. lock M5x0.8	M-547050-S	22	Linkage, throttle	24 079 01-S
2	Spring, choke return	24 089 03-S	23	Bushing, linkage retaining	25 158 11-S
3	Screw, hex. flange M6x1.0x16 (4)	M-645016-S	24	Spring, throttle limiter	24 089 51-S
4	Bracket, control	24 126 56-S			
5	Washer, plain 5.5 mm (3)	24 468 01-S			
6	Lever, throttle actuator	24 090 07-S			
7	Clamp, cable (2)	12 237 01-S			
8	Screw hex. flange M5x0.8x16 (3)	M-545016-S			
9	Lever, throttle control	24 090 03-S			
10	Nut, hex. M4x0.7	M-446030-S			
11	Screw, hex. cap M4x0.7x30	M-401030-S			
12	Linkage, choke	24 079 02-S			
13	Lever, choke	24 090 05-S			
14	Washer, spring 1/4	41 468 03-S			
15	Screw, hex. flange M5x0.8x20	M-545020-S			
16	Spring, governor	24 089 15-S			
17	Screw, hex. flange M6x1.0x25	SM-642025-S			
18	Lever, governor	24 090 14-S			
19	Nut, hex. flange M6x1.0	M-641060-S			
20	Spring, linkage	24 089 01-S			
21	Bushing, linkage retaining	25 158 08-S			

Obtain Parts from Kohler

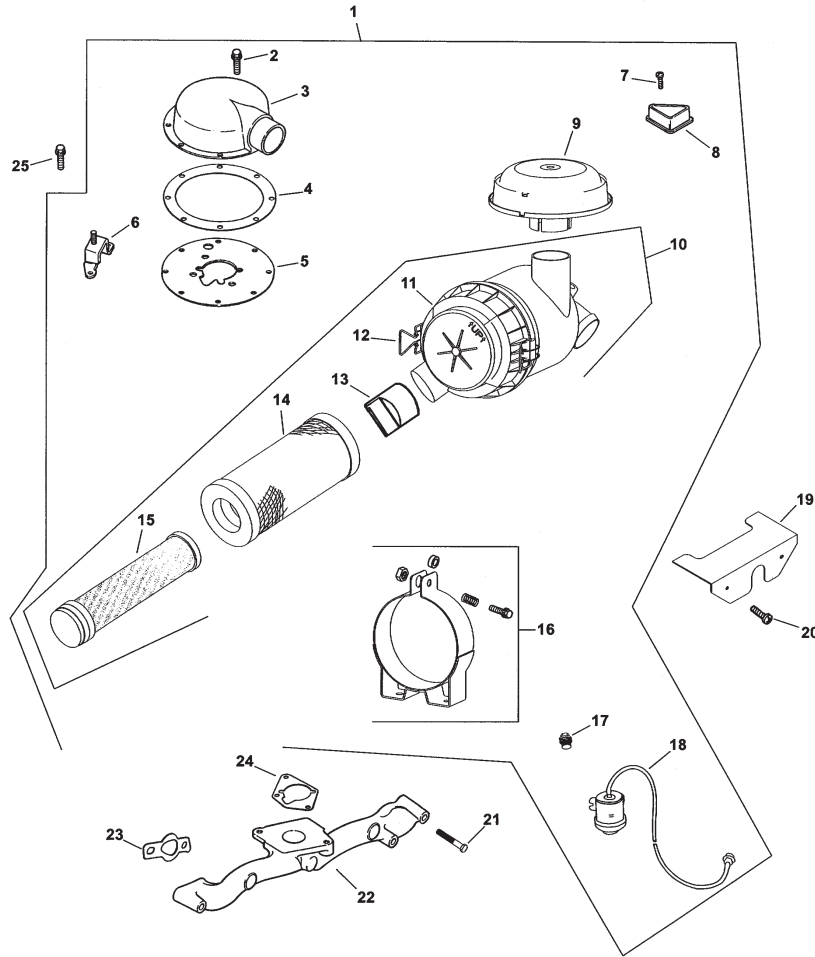

## Air Intake / Filtration (Kohler CH20S PS64644)

Ref. No.	Description	Part No.	Ref. No.	Description	Part No.
1	Kit, heavy duty air cleaner (Includes 2-18 & 24 853 77-S)	24 743 26-S			
2	Screw, hex. flange M6xx1.0x16 (7)	M-645016-S	21	Screw, hex. flange M6x1.0x55 (4)	M-651055-S
3	Adapter, air intake	24 029 28-S	22	Manifold, intake	24 164 14-S
4	Gasket, air cleaner adapter	24 041 38-S	23	Gasket, intake manifold (2)	24 041 01-S
5	Plate, adapter	24 029 35-S	24	Gasket, air cleaner base	24 041 06-S
6	Bracket, air cleaner base	24 126 21-S	25	Screw, hex. flange M6x1.0x16 (3)	M-639016-S
7	Screw, slotted hex. head (2)	X-67-3-S		NOT ILLUSTRATED	
8	Cover, blower housing (2)	24 096 17-S		Kit, carburetor with gaskets	24 853 77-S
9	Hood, air cleaner (5-1/4")	25 324 02-S		Decal, air cleaner	25 113 27-S
10	Cleaner assembly, air (incl. 11-15)	25 048 07-S			
11	Cover assembly	25 096 06-S			
12	Clip (2)	25 154 05-S			
13	Vavle, dust ejector	24 462 07-S			
14	Element, air filter-primary	25 083 01-S			
15	Element, air filter-safety	25 083 04-S			
16	Bracket assembly, air cleaner	25 126 02-S			
17	Plug, pipe	25 139 20-S			
18	Kit, air filter gauge	25 755 24-S			
19	Shield, debris	24 314 25-S			
20	Screw, phillips head 11-16x3/4" (2)	24 086 06-S			

Obtain Parts from Kohler



