



Wheel Horse®

16-38H Lawn Tractor

77104—200000001 & Up

Operator's Manual

Introduction

Thank you for purchasing a Toro product.

All of us at Toro want you to be completely satisfied with your new product, so feel free to contact your local Authorized Service Dealer for help with service, genuine Toro replacement parts, or other information you may require.

Whenever you contact your Authorized Service Dealer or the factory, always know the model and serial numbers of your product. These numbers will help the Service Dealer or Service Representative provide exact information about your specific product. You will find the model and serial number plate located in a unique place on the product as shown below.

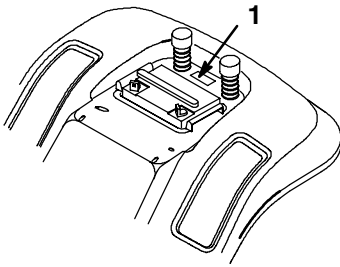

1856

1. Model and Serial Number Plate (under the seat)

For your convenience, write the product model and serial numbers in the space below.

Model No: _____
Serial No. _____

Read this manual carefully to learn how to operate and maintain your product correctly. Reading this manual will help you and others avoid personal injury and damage to the product. Although Toro designs, produces and markets safe, state-of-the-art products, you are responsible for using the product properly and safely. You are also responsible for training persons who you allow to use the product about safe operation.

The Toro warning system in this manual identifies potential hazards and has special safety messages that help you and others avoid personal injury, even death. DANGER, WARNING and CAUTION are signal words used to identify the level of hazard. However, regardless of the hazard, be extremely careful.



DANGER signals an extreme hazard that will cause serious injury or death if the recommended precautions are not followed.

WARNING signals a hazard that may cause serious injury or death if the recommended precautions are not followed.

CAUTION signals a hazard that may cause minor or moderate injury if the recommended precautions are not followed.

Two other words are also used to highlight information. “Important” calls attention to special mechanical information and “Note” emphasizes general information worthy of special attention.

The left and right side of the machine is determined by sitting on the seat in the normal operator’s position.

	WARNING:	
The engine exhaust from this product contains chemicals known to the State of California to cause cancer, birth defects, or other reproductive harm.		

SPARK ARRESTER NOTE

The engine in this product is not equipped with a spark arrester muffler. It is a violation of California Public Resource Code Section 4442 to use or operate this engine on any forest-covered, brush-covered or grass-covered land as defined in CPRC 4126. Other states or federal areas may have similar laws.

Contents

	Page		Page
Safety	2	Installing the Discharge Cover	20
Safe Operating Practices	2	Tips for Mowing Grass	21
Toro Riding Mower Safety	4	Maintenance	22
Slope Chart	7	Service Interval Chart	22
Safety and Instruction Decals	9	Greasing and Lubrication	23
Gasoline and Oil	11	Tire Pressure	23
Recommended Gasoline	11	Brake	24
Stabilizer/Conditioner	12	Wiring Diagram	25
Filling the Fuel Tank	12	Fuse	26
Check Engine Oil Level	12	Headlights	26
Operation	13	Battery	27
Think Safety First	13	Spark Plug	29
Controls	13	Fuel Tank	30
Parking Brake	13	Fuel Filter	30
Positioning the Seat	14	Air Cleaner	31
Headlights	14	Engine Oil	33
Using the Blade Control (PTO)	14	Cutting Blade	35
Setting the Height-of-Cut	15	Removing the Mower	36
Starting and Stopping the Engine	15	Installing the Mower	38
The Safety Interlock System	16	Blade Drive Belt	40
Operating-in-Reverse	17	Side-to-Side Mower Leveling	40
Testing the Safety System	18	Front-to-Rear Blade Slope	42
Pushing the Machine by Hand	18	Washing Underside of Mower	44
Driving Forward or Backward	19	Cleaning and Storage	44
Stopping the Machine	19	Troubleshooting	46
Side Discharge or Mulch Grass	20	The Toro Total Coverage Guarantee	50

The enclosed Engine Owner's Manual is supplied for information regarding The U.S. Environmental Protection Agency (EPA) and the California Emission Control Regulation of emission systems, maintenance and warranty.

Keep this engine Owner's Manual with your unit. Should this engine Owner's Manual become damaged or illegible, replace immediately. Replacements may be ordered through the engine manufacturer.

Safety

This machine meets or exceeds the B71.1-1998 specifications of the American National Standards Institute, in effect at the time of production. However, improper use or maintenance by the operator or owner can result in injury. To reduce the potential for injury, comply with these safety instructions and always pay attention to the safety alert ▲ symbol, which means CAUTION, WARNING, or DANGER—“personal safety instruction.” Failure to comply with the instruction may result in personal injury or death.

Safe Operating Practices

The following instructions are from ANSI standard B71.1—1998.

This product is capable of amputating hands and feet and throwing objects. Always follow all safety instructions to avoid serious injury or death.

General Operation

- Read, understand, and follow all instructions in the operator’s manual and on the machine before starting.
- Allow only responsible adults who are familiar with the instructions to operate the machine.
- Clear the area of objects such as rocks, toys, wire, etc., which could be picked up and thrown by the blade.
- Be sure the area is clear of other people before mowing. Stop the machine if anyone enters the area.
- Never carry passengers.
- Do not mow in reverse unless absolutely necessary. Always look down and behind before and while backing.
- Be aware of the mower discharge direction and do not point it at anyone. Do not operate the mower without either the entire grass catcher or the guard in place.
- Slow down before turning.
- Never leave a running machine unattended. Always turn off blades, set parking brake, stop engine, and remove keys before dismounting.
- Turn off blades when not mowing.
- Stop the engine before removing the grass catcher or unclogging the chute.
- Mow only in daylight or good artificial light.
- Do not operate the machine while under the influence of alcohol or drugs.
- Watch for traffic when operating near or crossing roadways.
- Use extra care when loading or unloading the machine into a trailer or truck.
- Always wear safety goggles or safety glasses with side shields when operating mower.
- Data indicates that operators, age 60 years and above, are involved in a large percentage of riding mower-related injuries. These operators should evaluate their ability to operate the riding mower safely enough to protect themselves and others from serious injury.

Slope Operation

Slopes are a major factor related to loss-of-control and tip-over accidents, which can result in severe injury or death. All slopes require extra caution. If you cannot back up the slope or if you feel uneasy on it, do not mow it.

- Mow up and down slopes, not across.
- Remove obstacles such as rocks, tree limbs, etc.
- Watch for holes, ruts or bumps. Uneven terrain could overturn the machine. Tall grass can hide obstacles.
- Use slow speed. Choose a low gear so that you will not have to stop or shift while on the slope.
- Follow Toro's recommendations for wheel weight or counterweights to improve stability.
- Use extra care with grass catchers or other attachments. These can change the stability of the machine.
- Keep all movement on slopes slow and gradual. Do not make sudden changes in speed or direction.
- Avoid starting or stopping on a slope. If tires lose traction, disengage the blades and proceed slowly straight down the slope.
- Do not turn on slopes unless necessary, and then, turn slowly and gradually downhill, if possible.
- Do not mow near drop-offs, ditches, or embankments. The machine could suddenly turn over if a wheel goes over the edge of a cliff or ditch, or if an edge caves in.
- Do not mow on wet grass. Reduced traction could cause sliding.
- Do not try to stabilize the machine by putting your foot on the ground.
- Do not use a grass catcher on steep slopes.

Children

Tragic accidents can occur if the operator is not alert to the presence of children. Children are often attracted to the machine and the mowing activity. Never assume that children will remain where you last saw them.

- Keep children out of the mowing area and under the watchful care of another responsible adult.
- Be alert and turn the machine off if children enter the area.
- Before and while backing, look behind and down for small children.
- Never carry children, even with the blades off. They may fall off and be seriously injured or interfere with safe machine operation.
- Never allow children to operate the machine.
- Use extra care when approaching blind corners, shrubs, trees, the end of a fence or other objects that may obscure vision.

Service

- Use extra care when handling gasoline and other fuels. They are flammable and vapors are explosive.
 - A. Use only an approved container.
 - B. Never remove the gas cap or add fuel when the engine is running. Allow the engine to cool before refueling. Do not smoke.
 - C. Never refuel the machine indoors.
 - D. Never store the machine or fuel container inside where there is an open flame, such as near a water heater or furnace.
- Never run a machine inside a closed area.
- Keep nuts and bolts tight, especially the blade attachment bolts. Keep equipment in good condition.

- Never tamper with safety devices. Check their proper operation regularly.
- Keep the machine free of grass, leaves, or other debris build-up. Clean up oil or fuel spillage. Allow the machine to cool before storing.
- Stop and inspect the equipment if you strike an object. Repair, if necessary, before restarting.
- Grass catcher components are subject to wear, damage and deterioration, which could expose moving parts or allow objects to be thrown. Frequently check components and replace with manufacturer's recommended parts, when necessary.
- Mower blades are sharp and can cut. Wrap the blade(s) or wear gloves, and use extra caution when servicing them.
- Use only genuine Toro replacement parts to ensure that original standards are maintained.

Toro Riding Mower Safety

The following list contains safety information specific to Toro products or other safety information that you must know that is not included in the ANSI standard.

WARNING

POTENTIAL HAZARD

- **Engine exhaust contains carbon monoxide, which is an odorless, deadly poison.**

WHAT CAN HAPPEN

- **Carbon monoxide can kill you and is also known to the State of California to cause birth defects.**

HOW TO AVOID THE HAZARD

- **Do not run engine indoors or in an enclosed area.**
- Stop the engine, disconnect spark plug wire(s) and remove key before performing any service, repairs, maintenance or adjustments.
- Slow down before turning. Sharp turns on any terrain may cause loss of control.
- Never leave a running machine unattended. Always turn off blades, set parking brake, stop engine, and remove the ignition and "Key Choice" keys before dismounting.
- Keep hands, feet, hair and loose clothing away from attachment discharge area, underside of mower and any moving parts while engine is running.
- Do not touch equipment or attachment parts which may be hot from operation. Allow to cool before attempting to maintain, adjust or service.
- Remove obstacles such as rocks, tree limbs, etc. from the mowing area. Watch for holes, ruts or bumps, as uneven terrain could overturn the machine. Tall grass can hide obstacles.

- Battery acid is poisonous and can cause burns. Avoid contact with skin, eyes and clothing. Protect your face, eyes and clothing when working with a battery.
- Battery gases can explode. Keep cigarettes, sparks and flames away from battery.
- Use only genuine replacement parts to ensure that original standards are maintained.
- Mow up and down slopes greater than 5°, not across.
- Mow downhill only on slopes above 10°, never mow uphill. If a steep slope must be ascended, back up the hill, and drive forward down the hill, keeping the machine in gear.
- Do not operate machine on hillsides or slopes exceeding 15°.
- Avoid turning on slopes. If you must turn, turn slowly and gradually downhill, if possible.
- Do not use a grass catcher on steep slopes. Heavy grass bags could cause loss of control or overturn the machine.
- Use only Toro-approved attachments. Warranty may be voided if used with unapproved attachments.

Slope Chart

Read all safety instructions on pages 2-8.

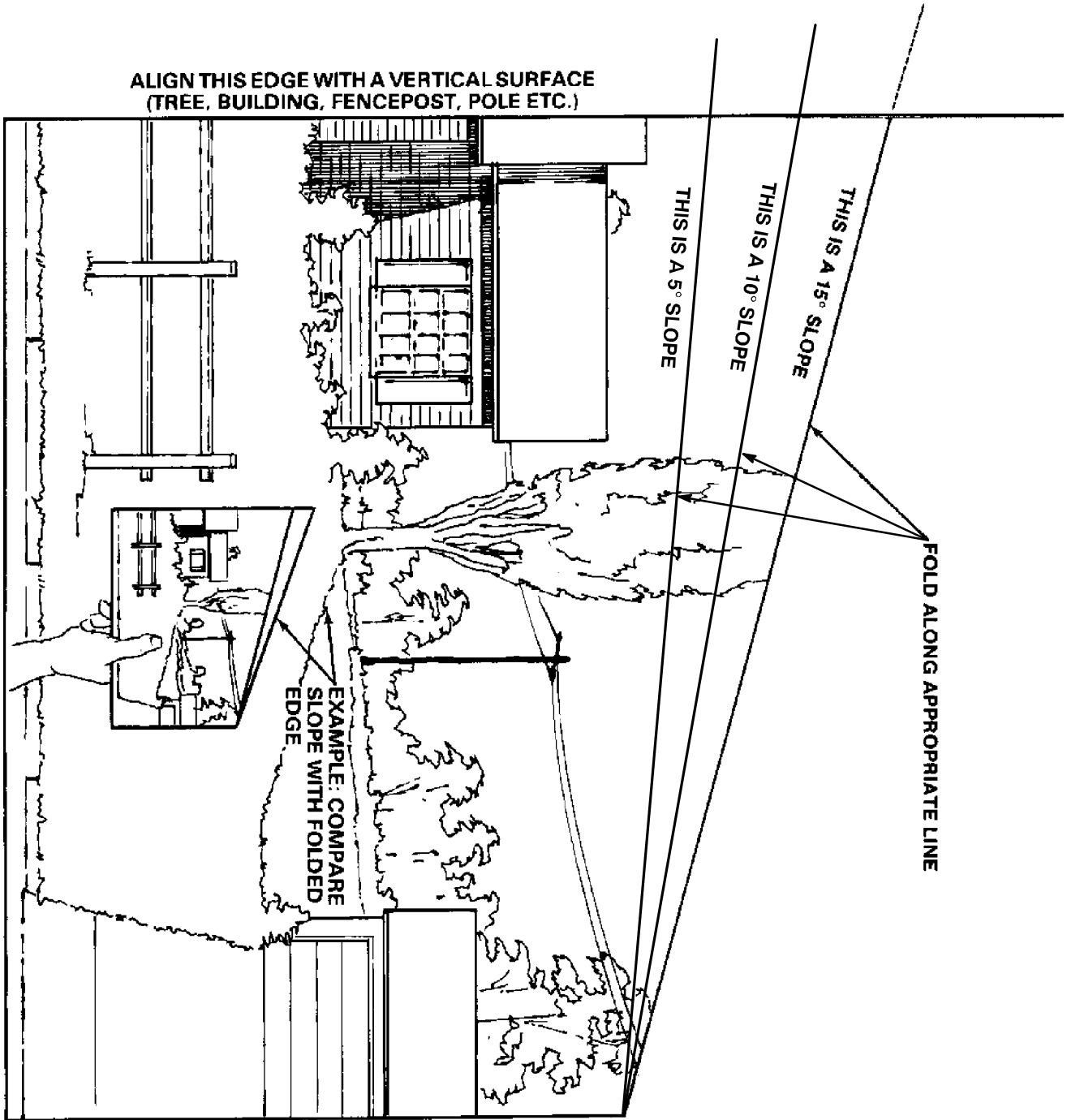

UNDER LEFT BELT GUIDE
(Part No. 68-3660)



ON MOWER LEFT SIDE
(Part No. 79-3140)

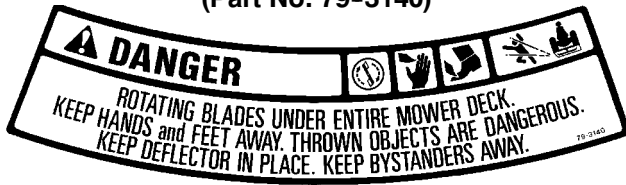

ON STEERING TOWER
(Part No. 92-2462)

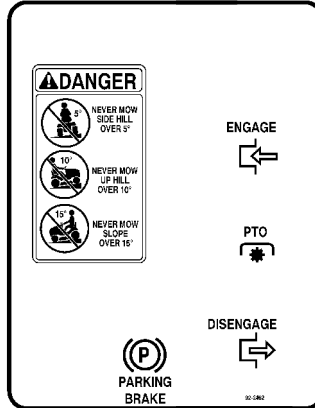

ON SEAT BRACKET
(Part No. 99-2985)



ON SEAT BRACKET
(Part No. 99-5339)



UNDER HOOD
(Part No. 100-6222)

XL SERIES
QUICK REFERENCE AID

SEE OPERATOR'S MANUAL

MODEL NUMBER	71225 / 16-38HXL	
PART NUMBERS		
DRIVE/TRANS BELT	88-6280	
DECK BELT	88-6250	
OIL FILTER	492932	
AIR ELEMENT	496894	
AIR PRE-CLEANER		
SPARK PLUG	491055	
SUGGESTED MAINTENANCE		
A. *ENGINE OIL	CHECK LEVEL BEFORE EVERY USE	CHANGE OIL / STORAGE SERVICE
B. GREASE CHASSIS		28W80 / STORAGE SERVICE
C. *AIR CLEANER	FOAM SERVICE / STORAGE SERVICE	PAPER-REPLACE / STORAGE SERVICE
E. BATTERY	SWR / STORAGE SERVICE / SPRING SERVICE	

*PERFORM ALL SCHEDULED MAINTENANCE UNDER DUSTY / DIRTY CONDITIONS

For complete maintenance schedules refer to your Toro Wheel Horse Owners Manual.

For dealer locator and more information on Toro products, contact:
www.toro.com

100-6222

Gasoline and Oil

Recommended Gasoline

Use UNLEADED Regular Gasoline suitable for automotive use (85 pump octane minimum). Leaded regular gasoline may be used if unleaded regular is not available.

IMPORTANT: Never use methanol, gasoline containing methanol, or gasohol containing more than 10% ethanol because the fuel system could be damaged. Do not mix oil with gasoline.

DANGER

POTENTIAL HAZARD

- In certain conditions gasoline is extremely flammable and highly explosive.

WHAT CAN HAPPEN

- A fire or explosion from gasoline can burn you, others, and cause property damage.

HOW TO AVOID THE HAZARD

- Use a funnel and fill the fuel tank outdoors, in an open area, when the engine is cold. Wipe up any gasoline that spills.
- Do not fill the fuel tank completely full. Add gasoline to the fuel tank until the level is 1/4" to 1/2" (6 mm to 13 mm) below the bottom of the filler neck. This empty space in the tank allows gasoline to expand.
- Never smoke when handling gasoline, and stay away from an open flame or where gasoline fumes may be ignited by a spark.
- Store gasoline in an approved container and keep it out of the reach of children. Never buy more than a 30-day supply of gasoline.

DANGER

POTENTIAL HAZARD

- In certain conditions gasoline is extremely flammable and highly explosive.

WHAT CAN HAPPEN

- A fire or explosion from gasoline can burn you, others, and cause property damage.

HOW TO AVOID THE HAZARD

- Always place gasoline containers on the ground away from your vehicle before filling.
- Do not fill gasoline containers inside a vehicle or on a truck or trailer bed because interior carpets or plastic truck bed liners may insulate the container and slow the loss of any static charge.
- When practical, remove gas-powered equipment from the truck or trailer and refuel the equipment with its wheels on the ground.
- If this is not possible, then refuel such equipment on a truck or trailer from a portable container, rather than from a gasoline dispenser nozzle.
- If a gasoline dispenser nozzle must be used, keep the nozzle in contact with the rim of the fuel tank or container opening at all times until fueling is complete.

Stabilizer/Conditioner

Use a fuel stabilizer/conditioner in the machine to provide the following benefits:

- Keeps gasoline fresh during storage of 90 days or less. For longer storage it is recommended that the fuel tank be drained.
- Cleans the engine while it runs
- Eliminates gum-like varnish buildup in the fuel system, which causes hard starting

IMPORTANT: Do not use fuel additives containing methanol or ethanol.

Add the correct amount of gas stabilizer/conditioner to the gas.

Note: A fuel stabilizer/conditioner is most effective when mixed with fresh gasoline. To minimize the chance of varnish deposits in the fuel system, use fuel stabilizer at all times.

Filling the Fuel Tank

1. Shut the engine off and set the parking brake.
2. Clean around fuel tank cap and remove the cap. Add unleaded regular gasoline to fuel tank, until the level is 1/4 to 1/2 inch (6 mm to 13 mm) below the bottom of the filler neck. This space in the tank allows gasoline to expand. Do not fill the fuel tank completely full.
3. Install fuel tank cap securely. Wipe up any gasoline that may have spilled.

Check Engine Oil Level

Before you start the engine and use the machine, check the oil level in the engine crankcase; refer to Checking Oil Level, page 33.

Operation

Think Safety First

Please carefully read all the safety instructions and symbols in the safety section. Knowing this information could help you, your family, pets or bystanders avoid injury.

Controls

Become familiar with all the controls (Fig. 1) before you start the engine and operate the machine.

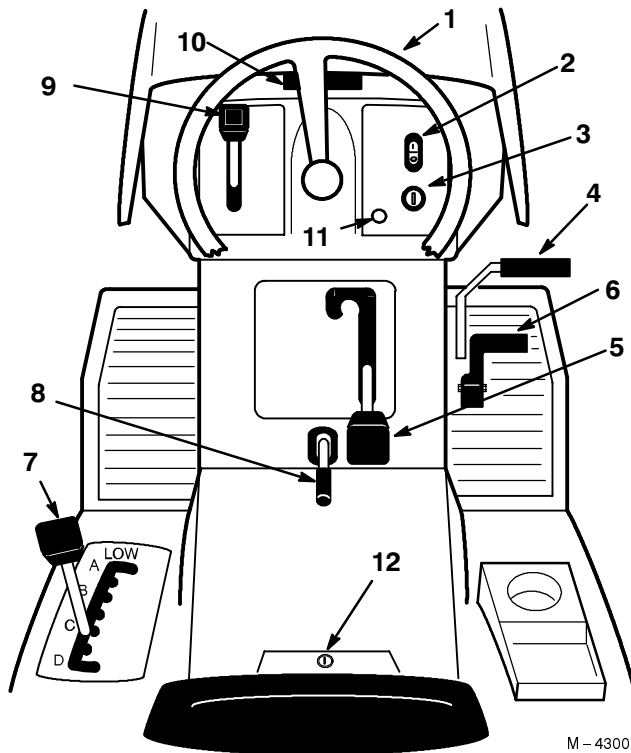

Figure 1

- | | |
|--|------------------------------------|
| 1. Steering wheel | 7. Height-of-cut lever (deck lift) |
| 2. Light switch—on/off (selected models) | 8. Parking brake lever |
| 3. Ignition switch | 9. Throttle lever |
| 4. Clutch/brake pedal | 10. Hood opening |
| 5. Blade control (PTO) | 11. Operating-in-Reverse light |
| 6. Ground speed selector | 12. Key Choice™ switch |

Parking Brake

Always set the parking brake when you stop the machine or leave it unattended.

Setting the Parking Brake

1. Push the brake pedal (Fig. 2) down and hold it in the depressed position.
2. Lift the parking brake lever (Fig. 2) up and gradually take your foot off the brake pedal. The brake pedal should stay in the depressed (locked) position.

Releasing the Parking Brake

1. Push down on the brake pedal (Fig. 2). The parking brake lever should release.
2. Gradually release the brake pedal.

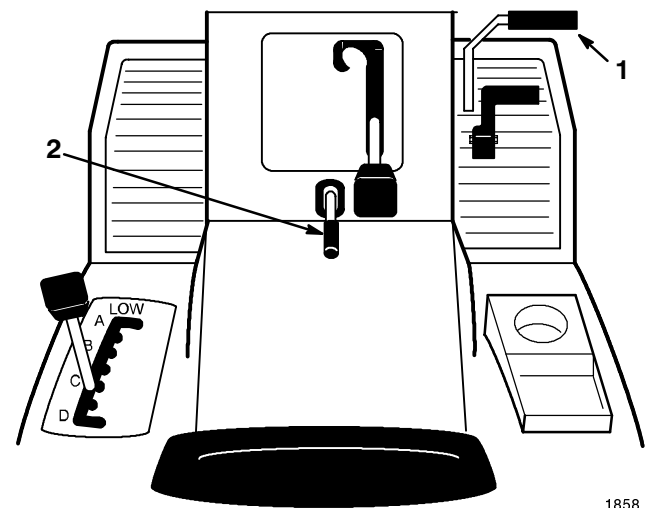

Figure 2

- | | |
|----------------|------------------------|
| 1. Brake pedal | 2. Parking brake lever |
|----------------|------------------------|

1858

Positioning the Seat

The seat can move forward and backward. Position the seat where you have the best control of the machine and are most comfortable.

1. Raise the seat and loosen the adjustment knob (Fig. 3).
2. Move the seat to the desired position and tighten the knob.

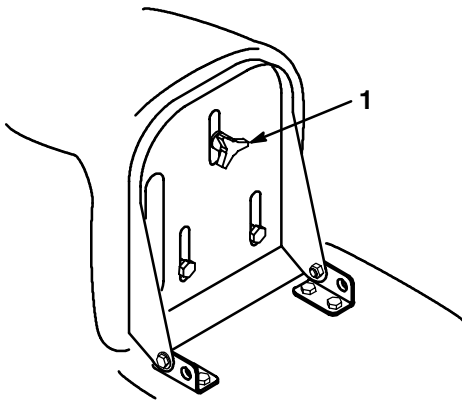

Figure 3

1862

1. Adjustment knob
-

Headlights

Headlights are optional on some models. A dash-mounted “ON/OFF” switch (Fig. 1) controls the headlights. The lights only shine while the engine is running and the switch is “ON.”

Using the Blade Control (PTO)

The blade control (PTO) engages and disengages power to the blade(s).

Engaging the Blade(s)

1. Depress the brake pedal to stop the machine.
2. Move the blade control (PTO) to “ENGAGED” (Fig. 4).

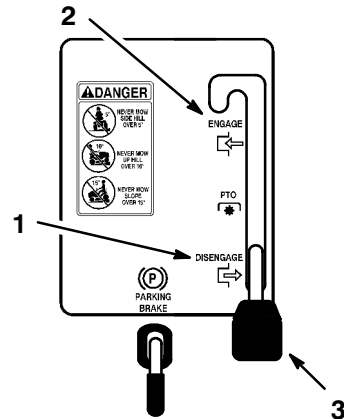

Figure 4

1852

1. Disengaged
 2. Engaged
 3. Blade control (PTO)
-

Disengaging the Blade(s)

1. Depress the brake pedal to stop the machine.
2. Move the blade control (PTO) to “DISENGAGED” (Fig. 4).

Setting the Height-of-Cut

The height-of-cut lever (deck lift) is used to raise and lower the mower to the desired cutting height.

1. The cutting height may be set in one of seven positions from approximately 1 to 4 inches (25 to 102 mm).
2. Pull on the height-of-cut lever (deck lift) and move it to the desired position (Fig. 5).

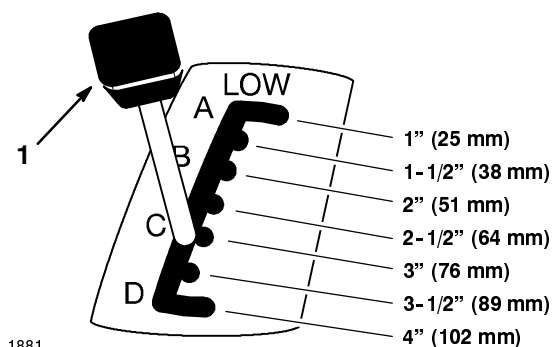

Figure 5

1. Height-of-cut lever (deck lift)

Starting and Stopping the Engine

Starting

1. Sit down on the seat.
2. Set the parking brake; refer to Setting the Parking Brake, page 13.

Note: The engine will not start unless you set the parking brake or fully depress the brake pedal.

3. Move the blade control (PTO) to “DISENGAGED” (Fig. 6).

4. Move the throttle lever to “CHOKE” (Fig. 7).

Note: An engine that has been running and is warm may not require step 4.

5. Turn the ignition key clockwise and hold it in the “START” position (Fig. 8). When the engine starts, release the key.

IMPORTANT: If the engine does not start after 30 seconds of continuous cranking, turn the ignition key to “OFF” and let the starter motor cool; refer to Troubleshooting, page 46.

6. After the engine starts, slowly move the throttle lever to “FAST” (Fig. 7). If the engine stalls or hesitates, move the throttle lever back to “CHOKE” for a few seconds. Then move the throttle lever to “FAST.” Repeat this as required.

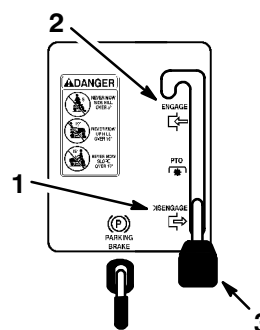
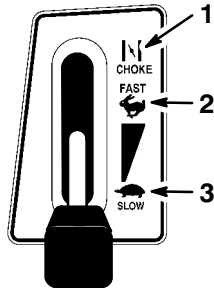

Figure 6

1. Disengaged
2. Engaged
3. Blade control (PTO)

1852



1859

Figure 7

1. Choke
2. Fast
3. Slow

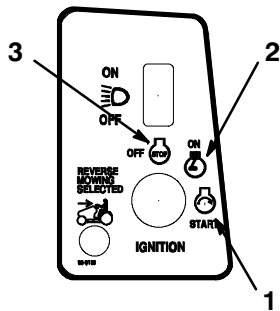

m-4297

Figure 8

1. Start
2. On
3. Off

The Safety Interlock System

Understanding the Safety Interlock System

The safety interlock system is designed to prevent the engine from starting unless:

- You are sitting on the seat
- The brake pedal is depressed
- The blade control (power take off/PTO) is “DISENGAGED”

The safety interlock system is designed to stop the engine if:

- You rise from the seat when the brake pedal is released
- You rise from the seat when the blade control (PTO) is “ENGAGED”.
- You shift into reverse with the blade control (PTO) engaged.

Stopping

1. Move the throttle lever to “FAST” (Fig. 7).
2. Turn the ignition key to “OFF” and remove the key (Fig. 8).

Operating-in-Reverse

An interlock feature is provided that prevents the Power Take Off (PTO) from operating while the tractor is traveling in reverse. If the unit is shifted into reverse while the mower blade or other PTO driven attachment is engaged, the engine will stop.

Do not mow while backing up unless it is absolutely necessary. If you need to mow while in reverse gear or use other PTO driven attachments (such as a snowthrower or tiller), this no operating-in-reverse interlock may be temporarily deactivated.

Before deactivating this interlock, be sure there are no children present on or near the property where you are using the tractor, and that none are likely to appear while you are mowing or operating an attachment. Be extra observant after you have chosen to deactivate the interlock because the sound of the tractor's engine might prevent you from being aware that a child or a bystander has entered the area where you are operating the tractor.

If you are certain that you can safely mow in reverse or operate an attachment, deactivate the no operating-in-reverse interlock by turning the Key Choice™ switch (Fig. 9), located on the seat bracket on the right hand side just below the seat, after engaging the blade (PTO). A red light on the front console (Fig. 10) will turn on as a reminder that the no operating-in-reverse interlock has been deactivated. Once the interlock is deactivated it stays in this mode—with your mower blade or PTO-driven attachment operating whenever you back up—and the console light stays on until either the blade (PTO) is disengaged, or the engine is turned off.

Note: Do not insert the “Key Choice” key unless it is absolutely necessary to mow in reverse or operate an attachment. The “Key Choice” key should also be removed from the unit if it will be operated by someone other than a responsible, experienced operator. This will prevent the unit from operating in reverse with the mower blade or other PTO attachment engaged. Always remove both the

ignition and the “Key Choice” keys and put them in a safe place out of the reach of children when leaving the unit unattended.

DANGER

POTENTIAL HAZARD

- A child or bystander could be backed over by a riding mower with its blade(s) engaged.

WHAT CAN HAPPEN

- Blade contact will cause serious personal injury or death.

HOW TO AVOID THE HAZARD

- Do not mow in reverse unless absolutely necessary.
- Always look backward and down before backing up.
- Use “Key Choice” switch only if you are certain no children or other bystanders will appear in the mowing area.
- Always remove both the ignition and “Key Choice” keys and put them in a safe place out of the reach of children or unauthorized users when leaving the unit unattended.

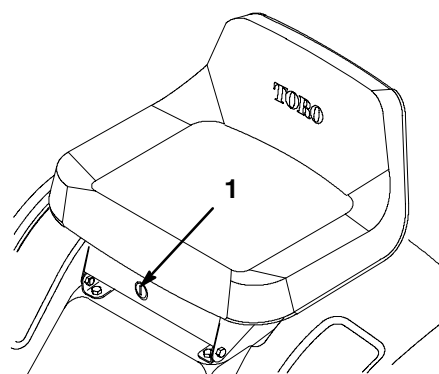

M-4157

Figure 9

1. “Key Choice” switch

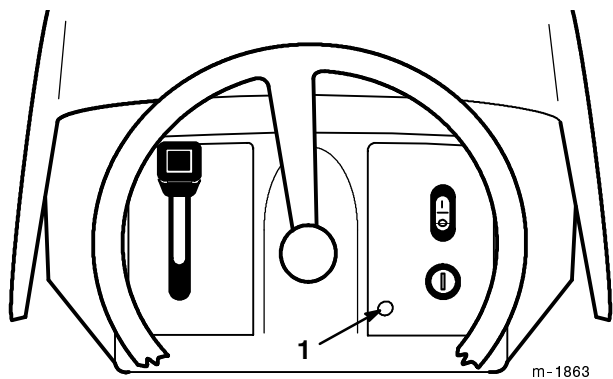

Figure 10

1. Operating-in-Reverse light

Testing the Safety System

Test the safety system before you use the machine each time. If the safety system does not operate as described below, have an Authorized Service Dealer repair the safety system immediately. While setting in the seat, perform the following checks.

1. Set the parking brake. Move the blade control (PTO) to “ENGAGED.” Now turn the ignition key to “START”; the engine should not crank.
2. Move the blade control (PTO) to “DISENGAGED” and release the parking brake. Now turn the ignition key to “START”; the engine should not crank.
3. Set the parking brake and move the blade control (PTO) to “DISENGAGED.” Now start the engine. While the engine is running, release the parking brake and rise slightly from the seat; the engine should stop.

4. Put the PTO lever in the “disengage” position and the traction control pedal in neutral. Now start the engine. While the engine is running, move the PTO lever to the “engage” position and move the foot pedal to reverse. The engine should stop.
5. Put the PTO lever in the “disengage” position and the traction control pedal in neutral. Now start the engine. Move the PTO lever to the “engage” position and turn the “Key Choice” key and release. The Operating-in-Reverse warning light should illuminate. Move the PTO lever to the “disengage” position and the Operating-in-Reverse warning light should turn off.

Pushing the Machine by Hand

IMPORTANT: Always push the machine by hand. Never tow the machine because transaxle damage may occur.

To Push the Machine

1. Disengage the blade control (PTO) and turn the ignition key to “OFF” to stop the engine.
2. Move the drive control to the “PUSH” position. This disengages the drive system and allows the wheels to turn freely (Fig. 11).

To Operate the Machine

1. Move the drive control to the “OPERATE” position. This engages the drive system (Fig. 11).

Note: The machine will not drive unless the drive control is in the “OPERATE” position.

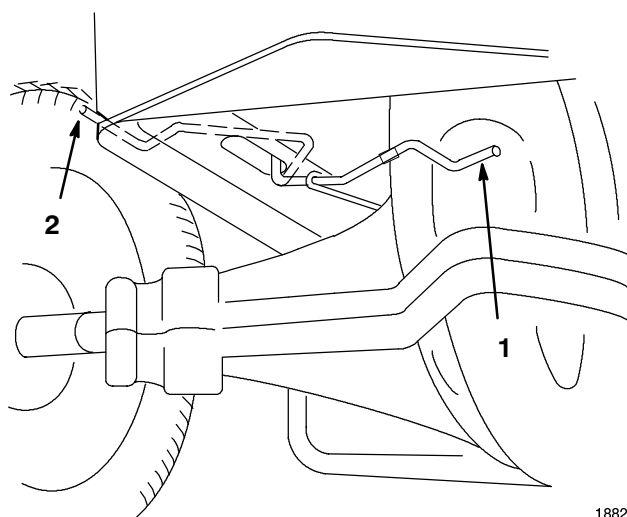

Figure 11

1. Operate position 2. Push position

Driving Forward or Backward

The throttle control regulates the engine speed as measured in rpm (revolutions per minute). Place the throttle control in the “FAST” position for best performance.

To go forward or backward, release the parking brake: refer to Releasing the Parking Brake, page 13. Place your foot on the traction control pedal and slowly press on the top of the traction control pedal to move forward or on the bottom of the traction control pedal to move backward (Fig. 12). The farther you move the traction control pedal in either direction, the faster the machine will move in that direction.

To slow down release the pressure on the traction control pedal.

IMPORTANT: To avoid transmission damage, always release the parking brake before moving the traction control pedal.

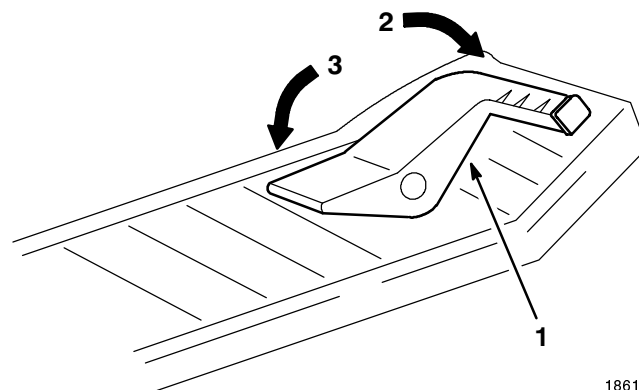

Figure 12

1. Traction control pedal 3. Backward
2. Forward

Stopping the Machine

To stop the machine, release the traction control pedal, disengage the blade control (PTO), and turn the ignition key to “OFF” to stop the engine. Also set the parking brake if you leave the machine unattended; refer to Setting the Parking Brake, page 13. Remember to remove the key from the ignition switch.

CAUTION

POTENTIAL HAZARD

- Someone could move or attempt to operate the tractor while it is unattended.

WHAT CAN HAPPEN

- Children or bystanders may be injured if they use the tractor.

HOW TO AVOID THE HAZARD

- Always remove the ignition and “key choice” keys and set the parking brake when leaving the machine unattended, even if just for a few minutes.

Side Discharge or Mulch Grass

DANGER

POTENTIAL HAZARD

- Without the grass deflector, discharge cover, or complete grass catcher assembly mounted in place, you and others are exposed to blade contact and thrown debris.

WHAT CAN HAPPEN

- Contact with rotating mower blade(s) and thrown debris will cause injury or death.

HOW TO AVOID THE HAZARD

- NEVER remove the grass deflector from the mower because the grass deflector routes material down toward the turf. If the grass deflector is ever damaged, replace it immediately.
- Never put your hands or feet under the mower.
- Never try to clear discharge area or mower blades unless you move the blade control (PTO) to “DISENGAGED” and rotate the ignition key to “OFF.” Also remove the key and pull the wire off the spark plug.

1. The mower has a hinged grass deflector that disperses clippings to the side and down toward the turf.
2. To mulch grass clippings you must install the discharge cover (optional on some models) into the opening in the side of the mower; refer to Installing the Discharge Cover, page 20.

Installing the Discharge Cover

To convert from side discharge to a mulching mower, install the discharge cover into the opening at the side of the mower.

1. Lift the grass deflector and slide the tabs on top of the discharge cover under the grass deflector retaining rod. Rotate the discharge cover down over the opening, and onto the lower lip of the mower (Fig. 13).
2. Secure the discharge cover to the lower lip of the mower with bolts and nuts (Fig. 13).

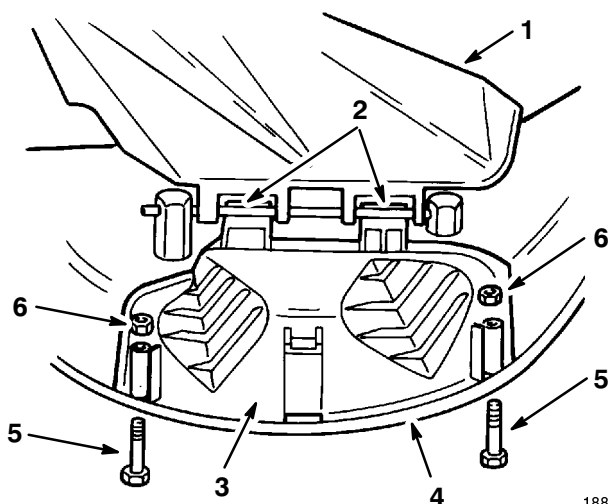

Figure 13

- | | |
|--------------------|--------------|
| 1. Grass deflector | 4. Lower lip |
| 2. Tabs under rod | 5. Bolt |
| 3. Discharge cover | 6. Nut |
3. To convert back to a side discharge mower, remove the discharge cover and lower the grass deflector over the discharge opening.

Tips for Mowing Grass

Fast Throttle Setting

For best mowing and maximum air circulation, operate the engine at “FAST.” Air is required to thoroughly cut grass clippings, so do not set the height-of-cut too low or totally surround the mower by uncut grass. Always try to have one side of the mower free from uncut grass, which allows air to be drawn into the mower.

Cutting a Lawn for the First Time

Cut grass slightly longer than normal to ensure the cutting height of the mower does not scalp any uneven ground. However, the cutting height used in the past is generally the best one to use. When cutting grass longer than six inches tall, you may want to cut the lawn twice to assure an acceptable quality-of-cut.

Cut 1/3 of the Grass Blade

It is best to cut only about 1/3 of the grass blade. Cutting more than that is not recommended, unless grass is sparse or it is late fall when grass grows more slowly.

Mowing Direction

Alternate mowing direction to keep the grass standing straight. This also helps disperse clippings which enhances decomposition and fertilization.

Mow at Correct Intervals

Normally, mow every 4 days. But remember, grass grows at different rates at different times. So to maintain the same cutting height, which is a good practice, mow more often in early spring. As the grass growth rate slows in mid summer, mow less frequently. If you cannot mow for an extended period, first mow at a high cutting height; then mow again 2 days later at a lower height setting.

Avoid Cutting Too Low

If the cutting width of the mower is wider than the mower you previously used, raise the cutting height one notch to ensure uneven turf is not cut too short.

Long Grass

If the grass is ever allowed to grow slightly longer than normal, or if it contains a high degree of moisture, raise the cutting height higher than usual and cut the grass at this setting. Then cut the grass again using the lower, normal setting.

When Stopping

If the machine’s forward motion must be stopped while mowing, a clump of grass clippings may drop onto your lawn. To avoid this:

1. With the blade(s) “ENGAGED,” move onto a previously cut area.
2. To disperse the clippings evenly, raise the mower one or two height-of-cut settings while driving forward with the blade(s) “ENGAGED.”

Keep the Underside of the Mower Clean

Use the washout port to clean clippings and dirt from the underside of the mower after each use. If grass and dirt build up inside the mower, cutting quality will eventually become unsatisfactory.

Blade Maintenance

Maintain a sharp blade throughout the cutting season because a sharp blade cuts cleanly without tearing or shredding the grass blades. Tearing and shredding turns grass brown at the edges, which slows growth and increases the chance of disease. Every 30 days, check the cutter blade(s) for sharpness and file down any nicks.

Maintenance

Service Interval Chart

Service Operation	Each Use	5 Hours	25 Hours	50 Hours	Storage Service	Spring Service	Notes
Oil—initial change		X					
Oil—periodic change			X		X		
Oil—check level	X						
Oil Filter				X			
Safety System—check	X	X	X			X	
Cutter Blade—check		X	X		X		
Brake—check		X	X		X	X	
Chassis—grease			X		X		More often in dusty, dirty conditions
Foam Air Cleaner—service			X		X		
Paper Air Cleaner—replace					X		
Spark Plug—check			X		X	X	
Belts—check for wear/cracks					X		
Gasoline—drain					X		
Engine—clean outside			X		X		
Mower Housing—clean	X	X			X		
Chipped Surfaces—paint					X		
Battery—charge, disconnect cables					X		
Fuel Filter—replace					X		
Tires—check pressure			X		X	X	

CAUTION

POTENTIAL HAZARD

- If you leave the key in the ignition switch, someone could start the engine.

WHAT CAN HAPPEN

- Accidental starting of the engine could seriously injure you or other bystanders.

HOW TO AVOID THE HAZARD

- Remove the key from the ignition switch and pull the wire off the spark plug before you do any maintenance. Also push the wire aside so it does not accidentally contact the spark plug.

Greasing and Lubrication

Service Interval/Specification

Grease the machine after every 25 operating hours or once a year, whichever occurs first. Grease more frequently when operating conditions are extremely dusty or sandy.

Grease Type: General-purpose grease.

How to Grease

1. Disengage the blade control (PTO), set the parking brake, and turn the ignition key to "OFF" to stop the engine.
2. Clean the grease fittings with a rag. Make sure to scrape any paint off the front of the fitting(s).
3. Connect a grease gun to the fitting. Pump grease into the fittings.
4. Wipe up any excess grease.

Where to Add Grease

1. Lubricate the front wheels until grease begins to ooze out the bearings (Fig. 14).

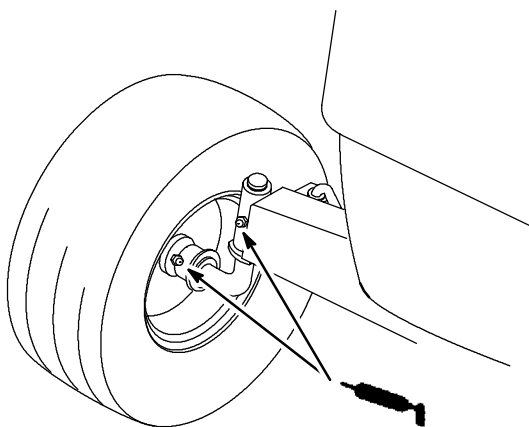

Figure 14

2346

Tire Pressure

Service Interval/Specification

Maintain the air pressure in the front and rear tires at 20 psi (138 kPa). Check the pressure at the valve stem after every 25 operating hours or yearly, whichever occurs first (Fig. 15). Check the tires when they are cold to get the most accurate pressure reading.

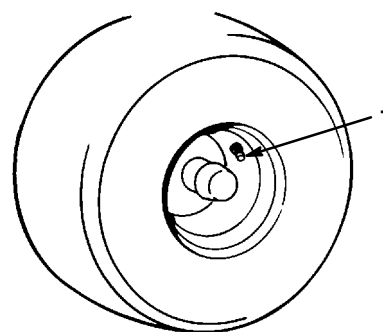

Figure 15

1872

1. Valve stem

Brake

The brake is on the right side of the rear axle, inside the rear tire (Fig. 16). If the parking brake does not hold securely, an adjustment is required.

Checking the Brake

1. Park the machine on a level surface, disengage the blade control (PTO), set the parking brake, and turn the ignition key to “OFF” to stop the engine.
2. Move the drive control wire to the “PUSH” position; refer to Pushing the Machine by Hand, page 18.
3. If the rear wheels lock and skid when you push the tractor forward, no adjustment is required. An adjustment is required if the wheels turn and do not lock; refer to Adjusting the Brake, page 24.

Adjusting the Brake

(0.020” (5.08 mm) feeler gauge required)

1. Check the brake before you adjust it; refer to Checking the Brake, page 24.
2. Release the parking brake; refer to Releasing the Parking Brake, page 13.
3. To adjust the brake remove the cotter pin and loosen the brake adjusting nut slightly (Fig. 16).
4. Carefully insert a 0.020” (5.08 mm) feeler gauge between the two outer brake pads (Fig. 16).
5. Tighten the brake adjusting nut until slight resistance is felt on the feeler gauge when sliding it in and out. Install cotter pin.
6. Check the brake operation again; refer to Checking the Brake, page 24.

IMPORTANT: With the parking brake released, the rear wheels must rotate freely when you push the mower. If the 0.020”

(5.08 mm) clearance and free wheel rotation cannot be achieved contact your service dealer immediately.

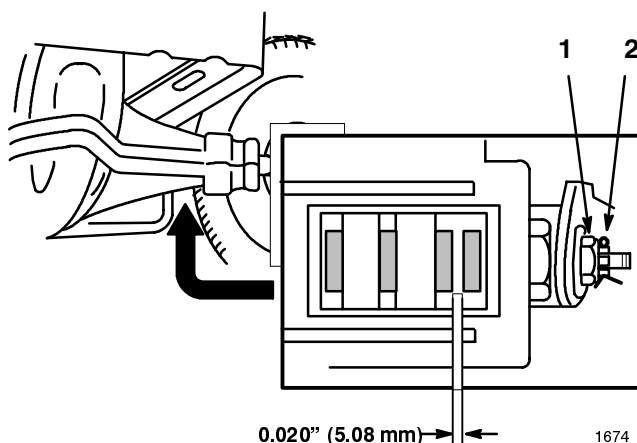
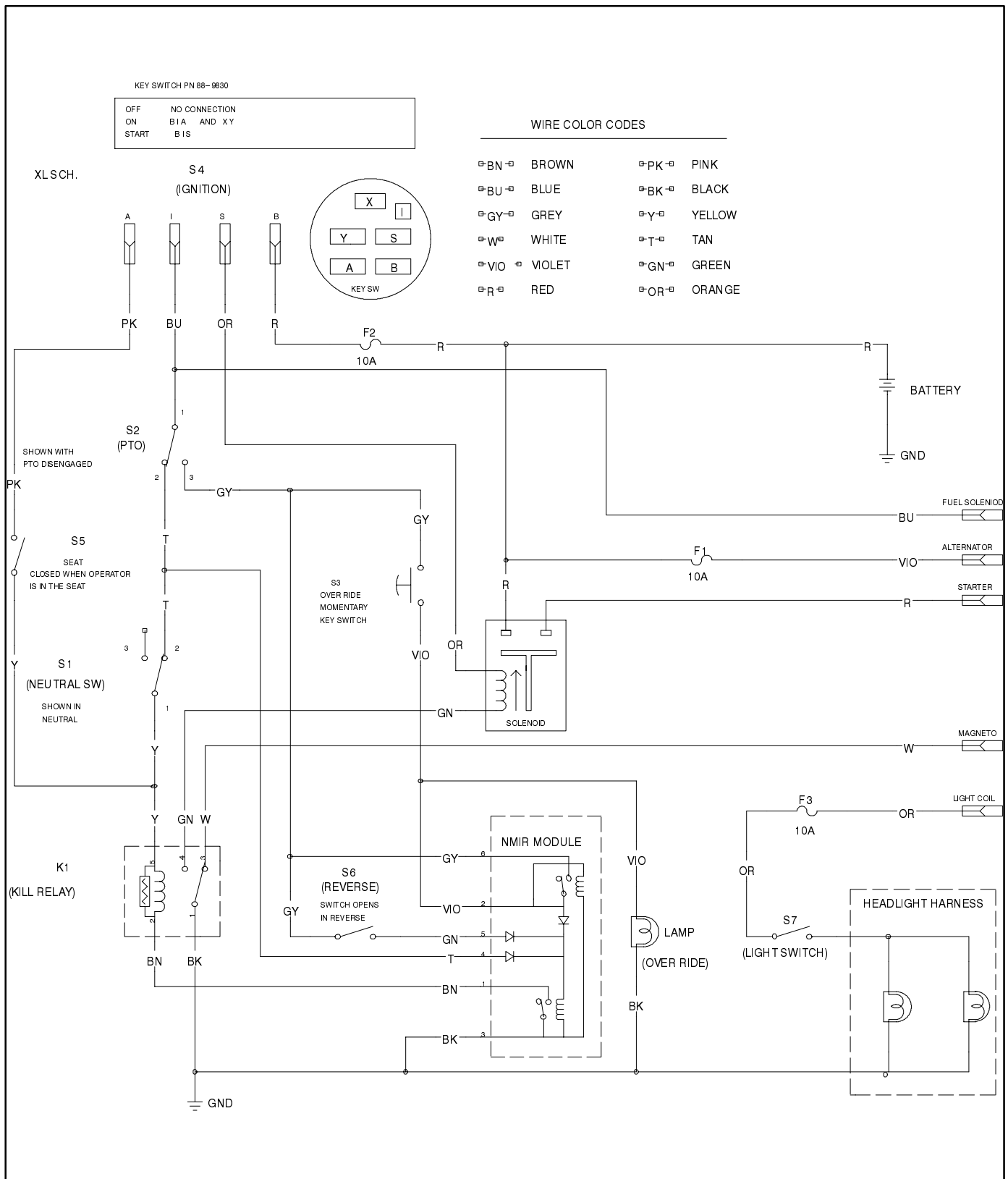

Figure 16

1. Brake adjusting nut
2. Cotter pin

Wiring Diagram



Fuse

Service Interval/Specification

The electrical system is protected by fuses. No maintenance is required, however, if a fuse blows check the circuit wiring for a short. To replace a fuse pull up (Fig. 17) to remove from the socket. Push down to insert.

Fuse: 10 amp, blade-type.

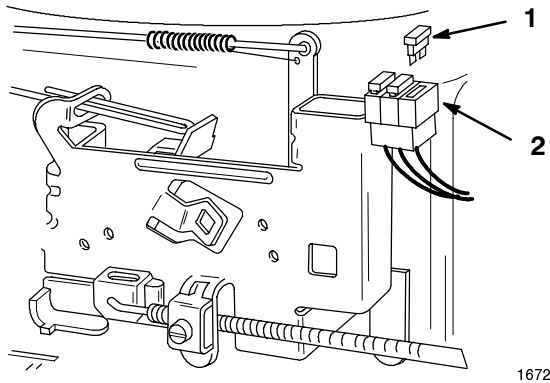

Figure 17

1. Fuse (removed)
2. Socket

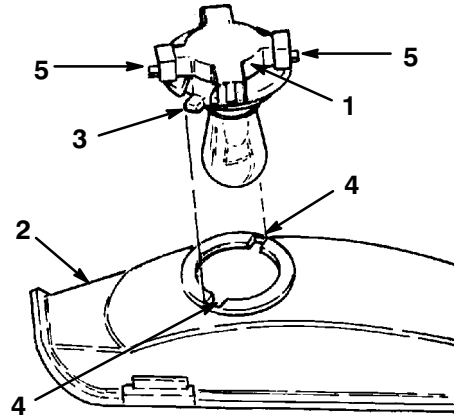

Figure 18

1. Bulb holder
2. Reflector
3. Tabs
4. Slots
5. Terminals

Installing the Bulb

1. The bulb has metal pins on the side of its base. Align the pins with the slots in the bulb holder and insert the base into the holder (Fig. 19). Push and rotate the bulb clockwise until it stops.

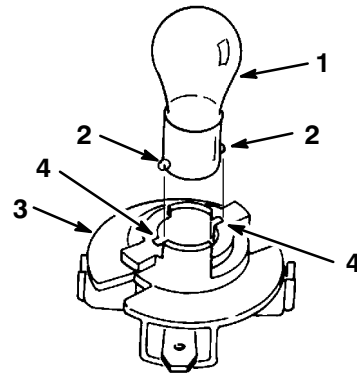

Figure 19

1. Bulb
2. Metal pins
3. Bulb holder
4. Slots

Headlights

Specification: Bulb # 1156, automotive type.

Removing the Bulb

1. Disengage the blade control (PTO), set the parking brake, and turn the ignition key to "OFF" to stop the engine.
2. Open the hood. Pull wire connectors off both bulb holder terminals.
3. Rotate the bulb holder 1/4 turn counterclockwise and remove it from the reflector (Fig. 18).
4. Push and rotate the bulb counterclockwise until it stops (approx. 1/4 turn) and remove bulb from the bulb holder (Fig. 19).

2. The bulb holder has two tabs (Fig. 18). Align the tabs with the slots in the reflector, insert the bulb holder into the reflector and rotate it 1/4 turn clockwise until it stops.
3. Push the wire connectors onto the terminals on the bulb holder.

Battery

Service Interval/Specification

Always keep the battery clean and fully charged. Use a paper towel to clean the battery and battery box. If the battery terminals are corroded, clean them with a solution of four parts water and one part baking soda. Apply a light coating of grease to the battery terminals to prevent corrosion.

Voltage: 12 v, 155 Cold Cranking Amps

Removing the Battery

1. Disengage the blade control (PTO), set the parking brake, and turn the ignition key to “OFF” to stop the engine.
2. Tip the seat forward to see the battery.
3. Disconnect the negative (black) ground cable from the battery post (Fig. 20).

IMPORTANT: Always disconnect the negative (black) cable first.

4. Slide the rubber cover up the positive (red) cable. Disconnect the positive (red) cable from the battery post (Fig. 20).
5. Remove the battery box and battery from the chassis.

WARNING

POTENTIAL HAZARD

- Either the battery terminals or metal tools could short against metal tractor components.
- Incorrect battery cable routing could damage the cables.

WHAT CAN HAPPEN

- Sparks can cause the battery gasses to explode.
- Damaged cables could short against metal tractor components and cause sparks.

HOW TO AVOID THE HAZARD

- When removing or installing the battery, do not allow the battery terminals to touch any metal parts of the tractor (below the headlights).
- Always **DISCONNECT** the negative (black) battery cable before disconnecting the positive (red) cable.
- Always **RECONNECT** the positive (red) battery cable before reconnecting the negative (black) cable .
- Do not allow metal tools to short between the battery terminals and metal parts of the tractor.
- Always keep the battery shield and hold-down rods in place to protect and secure the battery.
- Always route battery cables as illustrated.

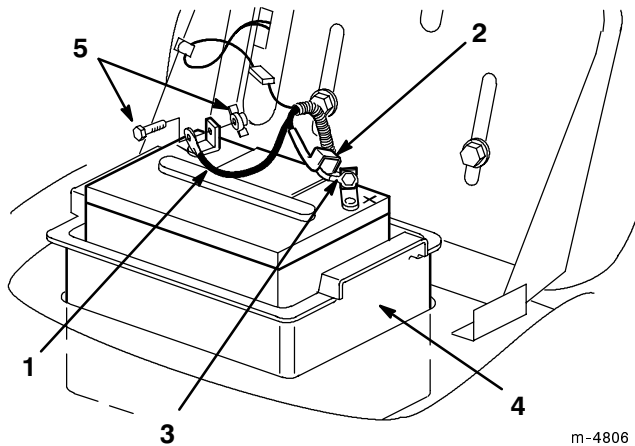

Figure 20

- | | |
|---------------------------|----------------------|
| 1. Negative cable (black) | 4. Battery box |
| 2. Rubber cover | 5. Bolt and wing nut |
| 3. Positive cable (red) | |

! DANGER

POTENTIAL HAZARD

- Battery electrolyte contains sulfuric acid which is a deadly poison and will cause severe burns.

WHAT CAN HAPPEN

- If electrolyte gets onto your skin, you will be burned.
- If you carelessly drink electrolyte, you could die.

HOW TO AVOID THE HAZARD

- Do not attempt to open, add electrolyte, or service the battery.
- Do not drink electrolyte.
- When handling battery, wear safety glasses to shield your eyes and rubber gloves to protect your hands.

Installing the Battery

1. Put the battery into the battery box and install into the chassis (Fig. 20).
2. Using the bolt and wing nut, connect the positive (red) cable to the positive (+) battery post (Fig. 20). Slide the rubber cover over the battery post.
3. Using the bolt and wing nut, connect the negative (black) cable to the negative (-) battery post (Fig. 20).

Charging the Battery

IMPORTANT: Always keep the battery fully charged. This is especially important to prevent battery damage when the temperature is below 32°F (0°C).

1. Remove the battery from the chassis; refer to Removing the Battery, page 27.
2. Connect a 3 to 4 amp battery charger to the battery posts. Charge the battery at a rate of 6-10 amperes for 1 hour (12 volts) Do not overcharge the battery.

! WARNING

POTENTIAL HAZARD

- Charging the battery produces gasses.

WHAT CAN HAPPEN

- Battery gasses can explode.

HOW TO AVOID THE HAZARD

- Keep cigarettes, sparks and flames away from battery.

3. Install the battery in the chassis; refer to Installing the Battery, page 28.

Spark Plug

Service Interval/Specification

Install a new spark plug after every 100 operating hours. Check the spark plug after every 25 operating hours. Make sure the air gap between the center and side electrodes is correct before installing the spark plug. Use a spark plug wrench for removing and installing the spark plug and a gapping tool/feeler gauge to check and adjust the air gap.

Type: Champion RC12YC (or equivalent)
Air Gap: 0.030" (0.762 mm).

Removing the Spark Plug

1. Disengage the blade control (PTO), set the parking brake, and turn the ignition key to "OFF" to stop the engine.
2. Open the hood.
3. Pull the wire off the spark plug (Fig. 21). Now clean around the spark plug to prevent dirt from falling into the engine and potentially causing damage.
4. Remove the spark plug and metal washer.

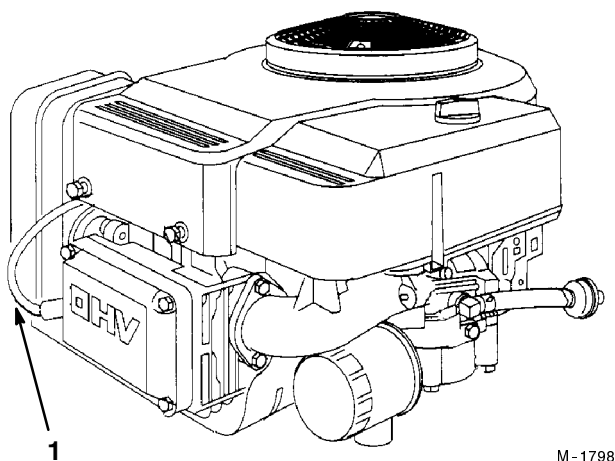

Figure 21

1. Spark plug wire

Checking the Spark Plug

1. Look at the center of the spark plug (Fig. 22). If you see light brown or gray on the insulator, the engine is operating properly. A black coating on the insulator usually means the air cleaner is dirty.

IMPORTANT: Never clean the spark plug. Always replace the spark plug when it has: a black coating, worn electrodes, an oily film, or cracks.

2. Check the gap between the center and side electrodes (Fig. 22). Bend the side electrode (Fig. 22) if the gap is not correct.

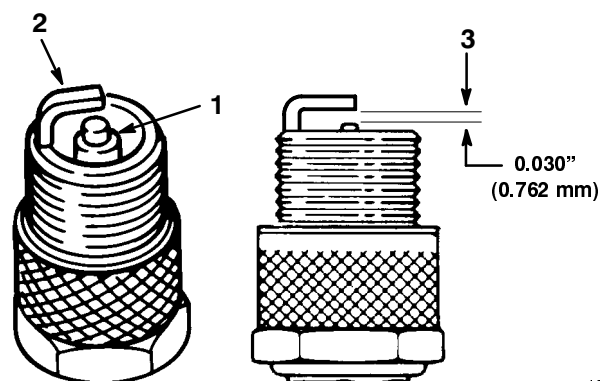

1870

Figure 22

1. Center electrode insulator
2. Side electrode
3. Air gap (not to scale)

Installing the Spark Plug

1. Install the spark plug and metal washer. Make sure the air gap is set correctly.
2. Tighten the spark plug to 15 ft-lb (20.4 Nm).
3. Push the wire onto the spark plug (Fig. 21).
4. Close the hood.

Fuel Tank

Draining The Fuel Tank

⚠ DANGER

POTENTIAL HAZARD

- In certain conditions gasoline is extremely flammable and highly explosive.

WHAT CAN HAPPEN

- A fire or explosion from gasoline can burn you, others, and cause property damage.

HOW TO AVOID THE HAZARD

- Drain gasoline from the fuel tank when the engine is cold. Do this outdoors in an open area. Wipe up any gasoline that spills.
- Never drain gasoline near an open flame or where gasoline fumes may be ignited by a spark.
- Never smoke a cigarette, cigar or pipe.

1. Park the machine so that the left front side is slightly lower than the right side to assure fuel tank drains completely. Then disengage the blade control (PTO), set the parking brake, and turn the ignition key to “OFF” to stop the engine.
2. Open the hood.
3. Squeeze the ends of the hose clamp together and slide it up the fuel line toward the fuel tank (Fig. 23).
4. Pull the fuel line off the filter (Fig. 23) and allow gasoline to drain into a gas can or drain pan.

Note: Now is the best time to install a new fuel filter because the fuel tank is empty.
5. Install the fuel line onto the filter. Slide the hose clamp close to the filter to secure the fuel line and filter.

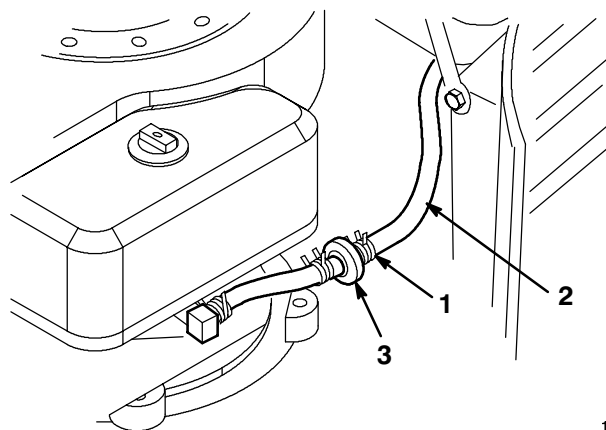

1873

Figure 23

- | | |
|---------------|-----------|
| 1. Hose clamp | 3. Filter |
| 2. Fuel line | |

Fuel Filter

Service Interval/Specification

Replace the fuel filter after every 100 operating hours or yearly, whichever occurs first.

Replacing the Fuel Filter

The best time to replace the fuel filter (Fig. 23) is when the fuel tank is empty. Never install a dirty filter if it is removed from the fuel line.

1. Disengage the blade control (PTO), set the parking brake, and turn the ignition key to “OFF” to stop the engine.
2. Open the hood.
3. Squeeze the ends of the hose clamps together and slide them away from the filter (Fig. 23).
4. Remove the filter from the fuel lines.
5. Install a new filter and move the hose clamps close to the filter.
6. Close the hood.

Air Cleaner

Service Interval/Specification

Foam Element: Clean and re-oil after every 25 operating hours, or yearly, whichever occurs first.

Paper Element: Replace after every 100 operating hours or yearly, whichever occurs first.

Note: Service the air cleaner more frequently (every few hours) if operating conditions are extremely dusty or sandy.

Removing the Foam and Paper Elements

1. Disengage the blade control (PTO), set the parking brake, and turn the ignition key to "OFF" to stop the engine.
2. Open the hood.
3. Clean around the air cleaner to prevent dirt from getting into the engine and causing damage. Unscrew the knob and remove the air cleaner cover (Fig. 24).

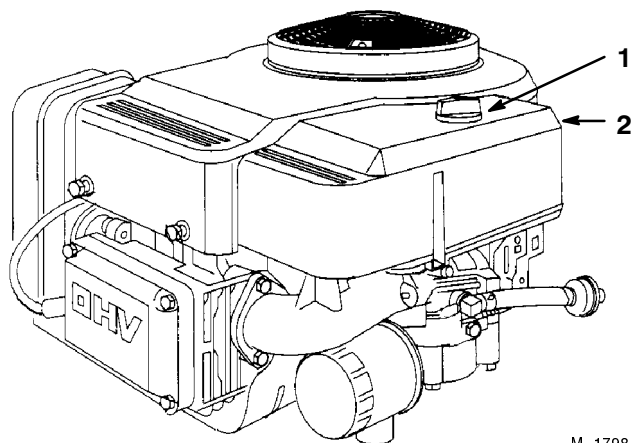

M-1798

Figure 24

1. Knob
2. Air cleaner cover

4. Carefully slide the foam element off the paper element (Fig. 25).

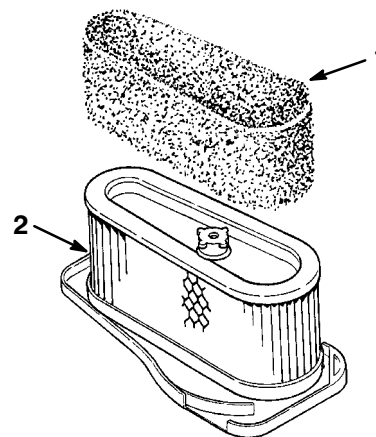

1864

Figure 25

1. Foam element
2. Paper element

5. Unscrew the rubber nut and remove the paper element (Fig. 26).

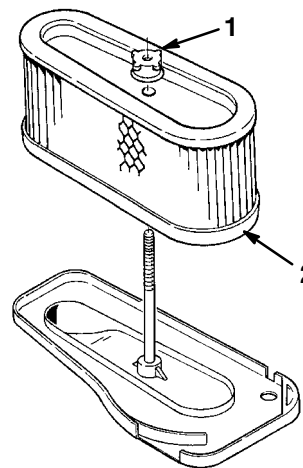

1865

Figure 26

1. Rubber nut
2. Paper element

Cleaning the Foam and Paper Elements

1. Foam Element

- A. Wash the foam element in liquid soap and warm water. When the element is clean, rinse it thoroughly.
- B. Dry the element by squeezing it in a clean cloth.
- C. Put one or two ounces of oil on the element (Fig. 27). Squeeze the element to distribute the oil.

IMPORTANT: Replace the foam element if it is torn or worn.

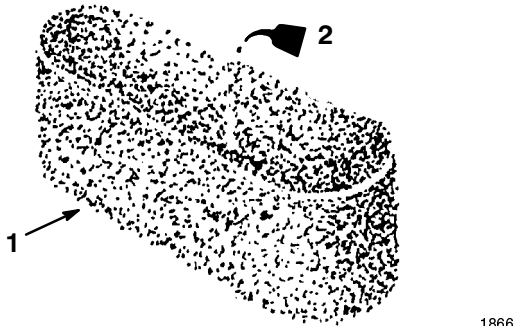

Figure 27

1. Foam element
2. Oil

2. Paper Element

- A. Lightly tap the element on a flat surface to remove dust and dirt (Fig. 28).
- B. Inspect the element for tears, an oily film, and damage to the rubber seal.

IMPORTANT: Never clean the paper element with pressurized air or liquids, such as solvent, gas, or kerosene. Replace the paper element if it is damaged or cannot be cleaned thoroughly.

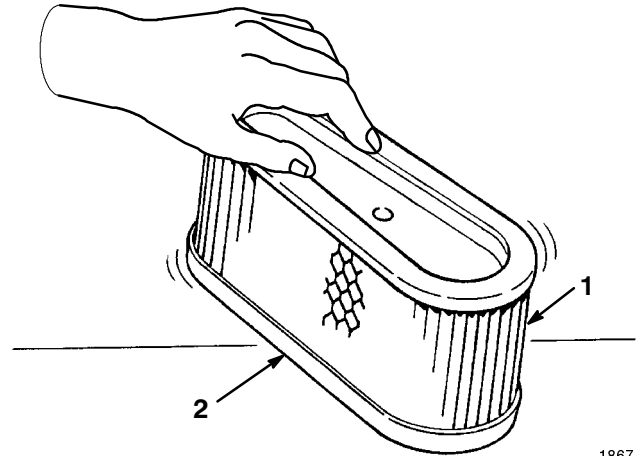

Figure 28

1. Paper element
2. Rubber seal

Installing the Foam and Paper Elements

IMPORTANT: To prevent engine damage, always operate the engine with the complete foam and paper air cleaner assembly installed.

1. Carefully slide the foam element onto the paper air cleaner element (Fig. 25).
2. Slide the air cleaner assembly onto the long rod. Now screw the rubber nut finger-tight against the air cleaner (Fig. 26).

Note: Make sure the rubber seal is flat against the air cleaner base.

3. Install the air cleaner cover and knob (Fig. 24). Tighten the knob snugly.
4. Close the hood.

Changing/Draining Oil

1. Start the engine and let it run five minutes. This warms the oil so it drains better.
2. Park the machine so that the right front side is slightly lower than the left side to assure the oil drains completely. Then disengage the blade control (PTO), set the parking brake, and turn the ignition key to “OFF” to stop the engine.
3. Open the hood.
4. Place a pan below the oil dipstick/fill tube and remove the drain plug (Fig. 30).
5. When oil has drained completely, install the drain plug.

Note: Dispose of the used oil at a certified recycling center.

6. Change oil filter (Fig. 31).
7. Slowly pour approximately 80% of the specified amount of oil into the filler tube (Fig. 29). Now check the oil level; refer to Checking Oil Level, page 33, steps 4-5.

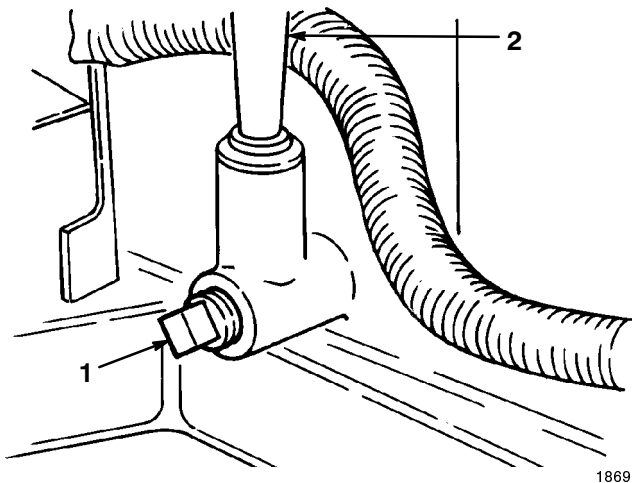

Figure 30

1. Oil drain plug
2. Oil dipstick/fill tube

Change Oil Filter—Service Interval/Specification

Replace the oil filter every 50 hours or every other oil change.

Note: Change oil filter more frequently when operating conditions are extremely dusty or sandy.

1. Drain the oil from the engine; refer to Changing/Draining Oil, page 34.
2. Remove the old filter and wipe the filter adapter (Fig. 31) gasket surface.
3. Apply a thin coat of new oil to the rubber gasket on the replacement filter (Fig. 31).

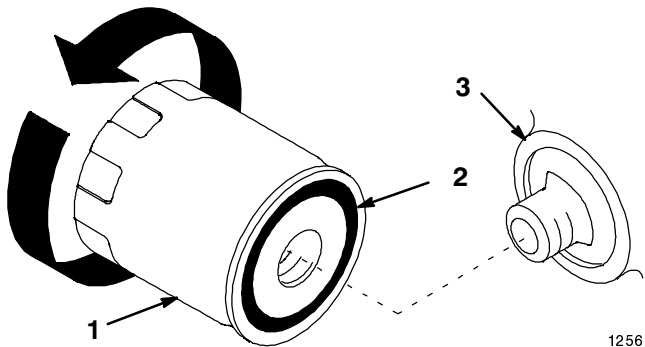

Figure 31

1. Oil filter
2. Gasket
3. Adapter

4. Install the replacement oil filter to the filter adapter. Turn the oil filter clockwise until the rubber gasket contacts the filter adapter, then tighten the filter an additional 1/2 turn (Fig. 31).
5. Slowly pour approximately 80% of the specified amount of oil into the filler tube (Fig. 29). Now check the oil level; refer to Checking Oil Level, page 33, steps 4 and 5.

Cutting Blade

To assure a superior quality of cut, keep the blade(s) sharp. For convenient sharpening and replacement, you may want to have an extra blade(s).

WARNING

POTENTIAL HAZARD

- A blade that is worn or damaged could break apart and pieces could be thrown at bystanders or at you as you use the mower.

WHAT CAN HAPPEN

- Pieces of blade that may be thrown could seriously injure or kill you or bystanders.

HOW TO AVOID THE HAZARD

- Periodically inspect the blade for wear and damage. Immediately install a new blade if it is worn or damaged.

Inspecting the Blade(s)

1. Remove the mower; refer to Removing the Mower, page 36.
2. Inspect the cutting edges (Fig. 32). If the edges are not sharp or have nicks, remove the blade(s) and sharpen them; refer to Sharpening the Blade(s), page 36.
3. Inspect the blade(s), especially the curved area (Fig. 32). If you notice any damage, wear, or a slot forming in this area (Fig. 32), immediately install a new blade.

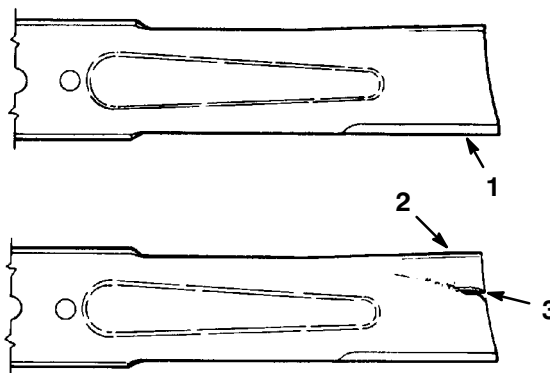

Figure 32

1. Cutting edge
2. Curved area
3. Wear/slot forming

151

Removing the Blade

1. Remove the mower; refer to Removing the Mower, page 36.
2. Carefully tip the mower over.
3. Remove the bolt (5/8" wrench), curved washer and blade (Fig. 33). A block of wood may be wedged between the blade and the mower to lock the blade when you are removing the bolt.
4. Inspect all parts. If a defect or damage is noticed, install new parts.

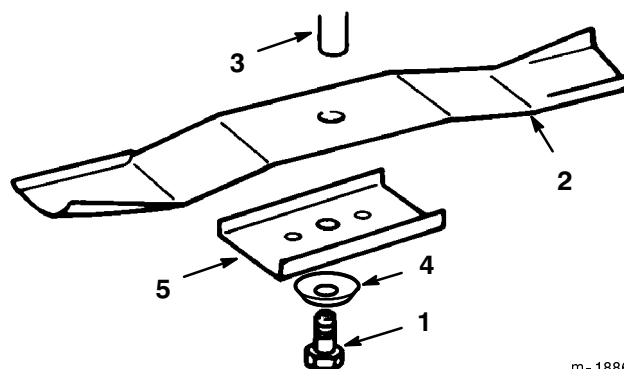

Figure 33

1. Bolt
2. Blade
3. Spindle
4. Curved washer
5. Stiffener (Recycler^P only)

m-1886

Sharpening the Blade(s)

1. Use a file to sharpen the cutting edge at both ends of the blade (Fig. 34). Maintain the original angle. The blade retains its balance if the same amount of material is removed from both cutting edges.



Figure 34

1. Sharpen at original angle

2. Check the balance of the blade by putting it on a blade balancer (Fig. 35). If the blade stays in a horizontal position, the blade is balanced and can be used. If the blade is not balanced, file some metal off the back side of the blade. Repeat this procedure until the blade is balanced.

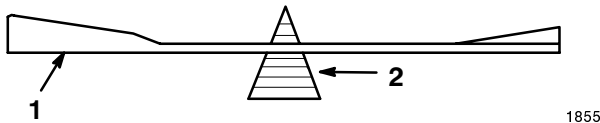

Figure 35

1. Blade
2. Balancer

Installing the Blade(s)

1. Install the blade, blade retainer, curved washer (cupped side toward blade), and the blade bolt (Fig. 33).

IMPORTANT: The curved part of the blade must be pointing toward the inside of the mower to assure proper cutting.

2. Tighten the blade bolt to 45-60 ft-lb (61-81 Nm).

Removing the Mower

1. Park the machine on a level surface, disengage the blade control (PTO), set the parking brake, and turn the ignition key to "OFF" to stop the engine.
2. Remove the key from the ignition switch and pull the wire off the spark plug.
3. Move the height-of-cut lever (deck lift) into the "D" notch.
4. Remove the height-of-cut lift assist spring from the retaining bolt (Fig. 36), using the spring tool provided with the machine. The spring is between the frame and the right rear wheel.

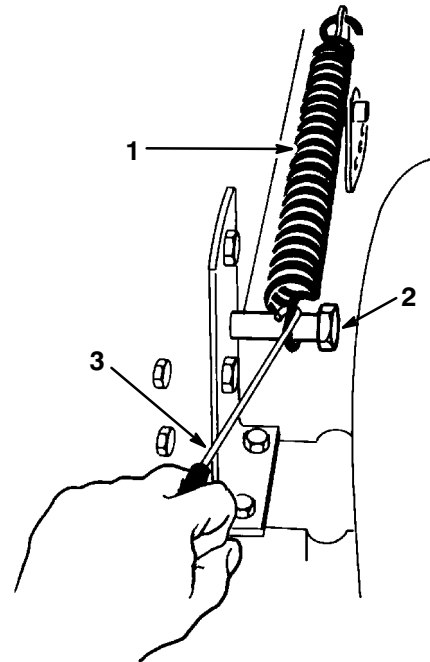

Figure 36

1. Spring
2. Bolt
3. Spring tool

CAUTION

POTENTIAL HAZARD

- The height-of-cut lever (deck lift) is spring-tensioned.

WHAT CAN HAPPEN

- When the mower is being removed, this spring-loaded mechanism could suddenly release and injure you or someone else.

HOW TO AVOID THE HAZARD

- Move the height-of-cut lever (deck lift) to the “D” position and remove the height-of-cut lift assist spring to release the spring tension.

5. Move the height-of-cut lever (deck lift) into the “A” notch.
6. Unhook the blade control (PTO) cable ring end from the idler spring (Fig. 37).
7. Remove rubber wiper and jam nut from blade control (PTO) cable at mounting bracket. Slide the cable from the bracket (Fig. 37).
8. Move the cable out of the way and lay inside frame rail so it cannot get caught in drive belts or pulleys.

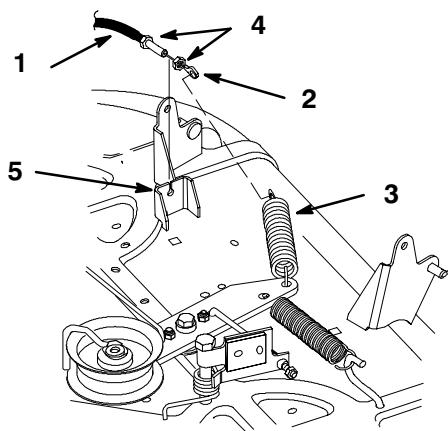
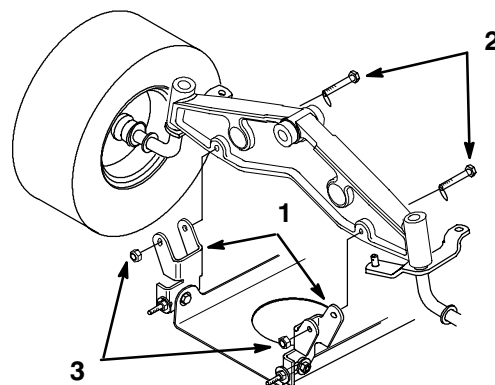

Figure 37

- | | |
|------------------------------|---------------------|
| 1. Blade control (PTO) cable | 4. Jam nut |
| 2. Ring end | 5. Mounting bracket |
| 3. Idler spring | |

9. Remove the bolts and lock nuts and pull the two mower pivot mount brackets down from the front axle (Fig. 38).



m-4630

Figure 38

- | | |
|--------------------------|-------------|
| 1. Pivot mount bracket | 3. Lock nut |
| 2. Bolt 5/16-18 x 2-1/2" | |

10. Remove the hair pin cotter and washer from the end of the long rod (Fig. 39). Now slide the rod out of the mower mount. Repeat this step on the opposite side of the mower.
11. Remove the hairpin cotter and washer at the mower leveling bracket (Fig. 39). Slide the bracket off the mounting pin. Re-install the washer and hairpin cotter for storage.
12. Rotate the leveling bracket up, toward the frame, and hook the long rod into one of the holes to store. Secure long rod with washer and hairpin cotter. Repeat for opposite side of the mower.
13. Move the height-of-cut lever (deck lift) into the “D” notch. Hook lift assist spring onto retaining bolt for storage (Fig. 36).

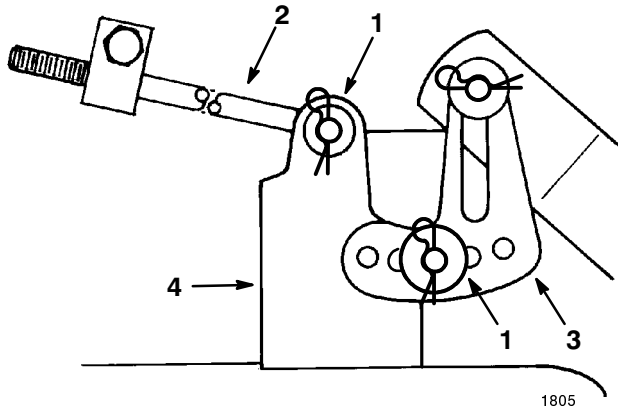

Figure 39

- | | |
|------------------------------|---------------------|
| 1. Hairpin cotter and washer | 3. Leveling bracket |
| 2. Long rod | 4. Mower mount |

14. Remove the mower belt from the lower engine pulley (Fig. 40). If you are careful, you can flex the belt guide(s) just far enough away from the pulley to remove the belt. If it is too difficult to remove the belt, loosen the bolts and nuts securing the belt guides.

IMPORTANT: Do not bend the belt guide(s) away from the pulley because the belt will not operate properly when the mower is installed later.

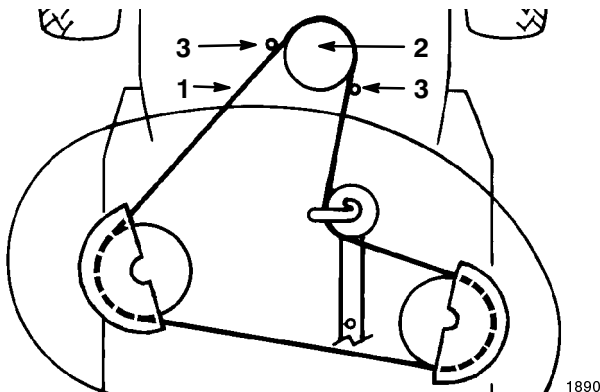

Figure 40

Top View

- | | |
|------------------|----------------|
| 1. Mower belt | 3. Belt guides |
| 2. Engine pulley | |

15. Turn the front wheels fully to the left. Slide the mower out to the right to complete removal.

Installing the Mower

1. Park the machine on a level surface, disengage the blade control (PTO), set the parking brake, and turn the ignition key to "OFF" to stop the engine.
2. Remove the key from the ignition switch and pull the wire off the spark plug.
3. Turn the front wheels fully to the left. Slide the mower under the chassis from the right side.
4. Install mower belt onto the lower engine pulley (Fig. 40). If you are careful, you can flex the belt guide(s) just far enough away from the pulley to install the belt. If it is too difficult to install the belt, loosen the bolts and nuts securing the belt guides.

IMPORTANT: Do not bend the belt guide(s) away from the pulley. There must be a maximum 1/8" (3.2 mm) between the belt guide(s) and the edge of the pulley to keep the belt on the pulley during operation. If the space is more than 1/8" (3.2 mm), adjust the belt guide(s) and tighten them securely. The belt guide(s) must not contact the pulley.

5. Install the mower pivot mount brackets to the front axle with bolts and lock nuts (Fig. 41).

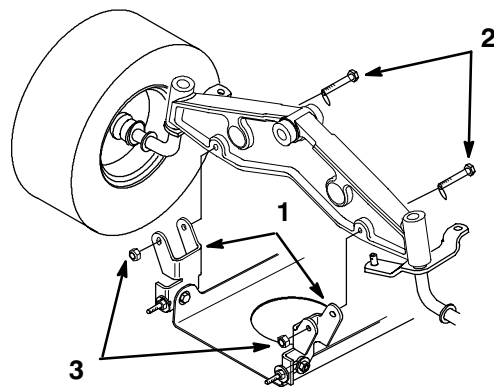

Figure 41

- | | |
|--------------------------|-------------|
| 1. Pivot mount bracket | 3. Lock nut |
| 2. Bolt 5/16-18 x 2-1/2" | |

6. Move the height-of-cut lever (deck lift) into the "A" notch.
7. Slide the end of the long rod through the hole in the mower mount (Fig. 42). Install the washer and hair pin cotter to secure the rod in place. Repeat this step on the opposite side of the mower.
8. Mount the slotted mower leveling bracket onto the pin on the height-of-cut arm (Fig. 42). Install the washer and hair pin cotter to secure the mower. Repeat this step on the opposite side of the mower.

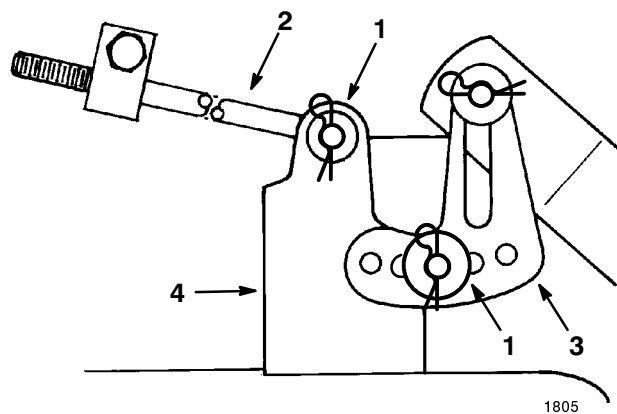

Figure 42

- | | |
|------------------------------|---------------------|
| 1. Hairpin cotter and washer | 3. Leveling bracket |
| 2. Long rod | 4. Mower mount |

9. Look under tractor and take down blade control (PTO) cable nested inside frame rail.
10. Remove first jam nut and thread second jam nut onto the blade control (PTO) cable all the way. Route cable through slot in deck bracket and thread second jam nut onto cable (Fig. 43).
11. Hook end of blade control (PTO) cable onto idler spring (Fig. 43).

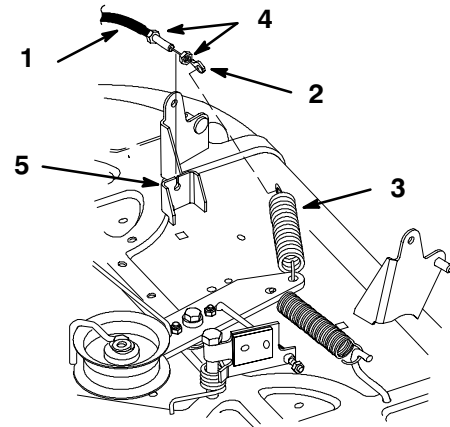

Figure 43

- | | |
|------------------------------|---------------------|
| 1. Blade control (PTO) cable | 4. Jam nut |
| 2. Ring end | 5. Mounting bracket |
| 3. Idler spring | |

12. Engage blade control (PTO) lever on dash. Measure distance between hook ends of idler spring (Fig. 44). Adjust jam nuts so 6" (150 mm) dimension is obtained (Fig. 44).
13. Tighten jam nuts securely, replace rubber wiper and disengage blade control (PTO).

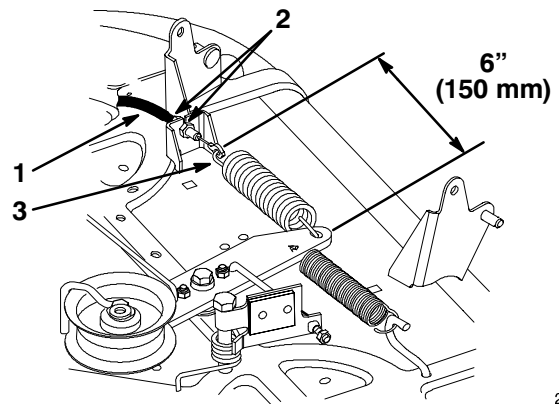

Figure 44

- | | |
|------------------------------|-----------------|
| 1. Blade control (PTO) cable | 3. Idler spring |
| 2. Jam nut | |

2384

1805

2385

14. Move the height-of-cut lever (deck lift) into the “D” notch to make it easier to install the height-of-cut lift assist spring.
15. Hook the height-of-cut lift assist spring onto the retaining bolt (Fig. 36), using the spring tool provided with the machine.
16. Check side-to-side blade level; refer to Side-to-Side Mower Leveling, page 40.

Blade Drive Belt

Removing the Blade Drive Belt

1. Remove the mower; refer to Removing the Mower, page 36.
2. Remove the pulley cover mounting screws and pulley covers from both blade pulleys (Fig. 45).
3. Loosen, but do not remove the bolt and nut securing the idler pulley and belt guide (Fig. 45).
4. Remove the belt from the pulleys.

Installing the Blade Drive Belt

1. Install the new belt around the blade pulleys and under the belt guide on the idler pulley.
2. Position the idler pulley belt guide so it points toward the left, 90° to the idler arm (Fig. 45). Tighten the mounting bolt and lock nut securing the idler pulley and belt guide.
3. Install the left and right pulley covers with the mounting screws (Fig. 45).
4. Install the mower; refer to Installing the Mower, page 38.

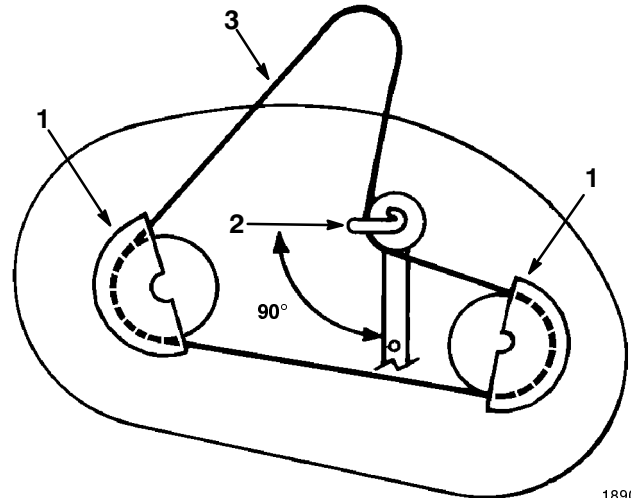

Figure 45

Top View

1. Pulley cover
2. Idler pulley belt guide position
3. Mower belt

Side-to-Side Mower Leveling

The mower blades must be level from side to side. Check the side-to-side level any time you install the mower or when you see an uneven cut on your lawn. Before you level the mower, set the air pressure in the front and rear tires to the recommended inflation. Refer to “Tire Pressure” (page 23) in the Maintenance Section.

1. Park the machine on a level surface, disengage the blade control (PTO), set the parking brake, and turn the ignition key to “OFF” to stop the engine.
2. Remove the key from the ignition switch and pull the wire off the spark plug.
3. Move the height-of-cut lever (deck lift) into the “C” notch.

4. Carefully rotate blade(s) side to side (Fig. 46). Measure between the outside cutting edges and the flat surface (Fig. 46). If both measurements are not within 3/16" (4.8 mm), an adjustment is required; refer to steps 5 and 6.

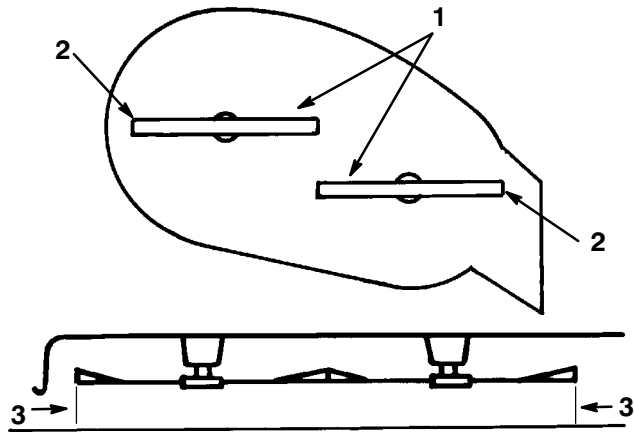

1891

Figure 46

- | | |
|--------------------------|-----------------|
| 1. Blades side to side | 3. Measure here |
| 2. Outside cutting edges | |

5. Remove the hair pin cotter and washer from the leveling bracket (Fig. 47). To level the blade(s), reposition the leveling bracket(s) in a different hole and install the washer and hair pin cotter. (Fig. 47). A front hole lowers the blade height and a rear hole raises its height. Repeat this procedure on the opposite side.

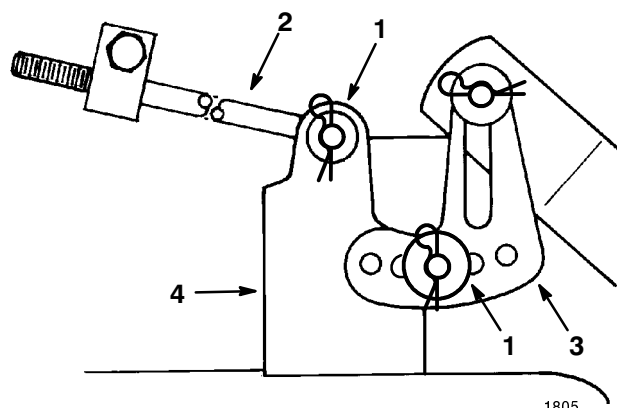

1805

Figure 47

- | | |
|------------------------------|---------------------|
| 1. Hairpin cotter and washer | 3. Leveling bracket |
| 2. Long rod | 4. Mower mount |

6. Now check the front-to-rear blade slope; refer to Front-to-Rear Blade Slope, page 42.

Front-to-Rear Blade Slope

Check the front-to-rear blade slope any time you install the mower. Before you check the slope, set the air pressure in the front and rear tires to the recommended inflation. Refer “Tire Pressure” (page 23) in the Maintenance Section. If the front of the mower is not within a range of 1/8”–3/8” (3.5 mm–10.5 mm) lower than the rear of the mower, adjust the blade slope using the following instructions:

1. Park the machine on a level surface, disengage the blade control (PTO), set the parking brake, and turn the ignition key to “OFF” to stop the engine.
2. Remove the key from the ignition switch and pull the wire off the spark plug.
3. Check and adjust side-to-side blade level if you have not checked the setting; refer to Side-to-Side Mower Leveling, page 40.
4. Move the height-of-cut lever (deck lift) into the “C” notch.
5. Measure the length of the rod extending out the front of the adjusting block on the sides of the chassis (Fig. 48). If the rod length is not 5/8” (15.9 mm), remove the hair pin cotter and washer from the end of the rod (Fig. 48), and turn the rod until the 5/8” (15.9 mm) dimension is obtained. Then install the end of the rod into the hole in the mower mount and secure in place with washer and hair pin cotter. Repeat this procedure on the opposite side of the mower.
6. Check the front to rear slope by measuring between the bottom of the mower (front center and rear center) and the flat surface (Fig. 49). If the front is not within a range of 1/8”–3/8” (3.5mm–10.5mm) lower than the rear, an adjustment is required.

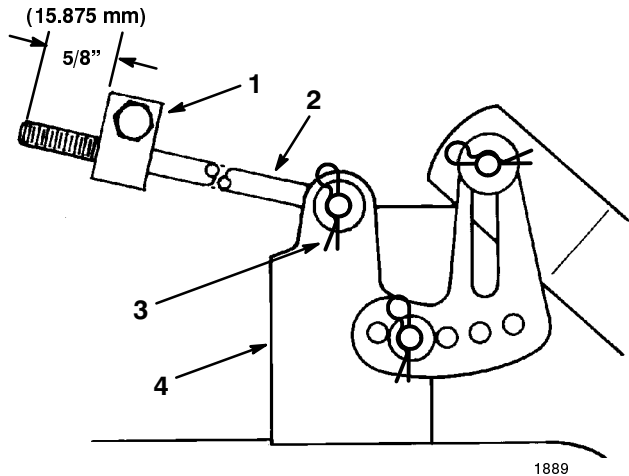

Figure 48

- | | |
|--------------------|------------------------------|
| 1. Adjusting block | 3. Hairpin cotter and washer |
| 2. Long rod | 4. Mower mount |

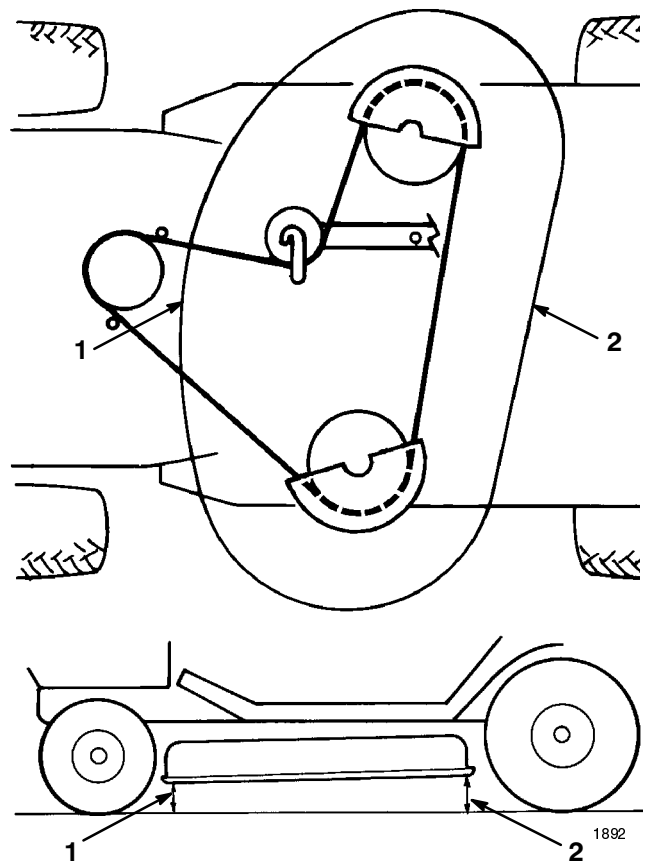
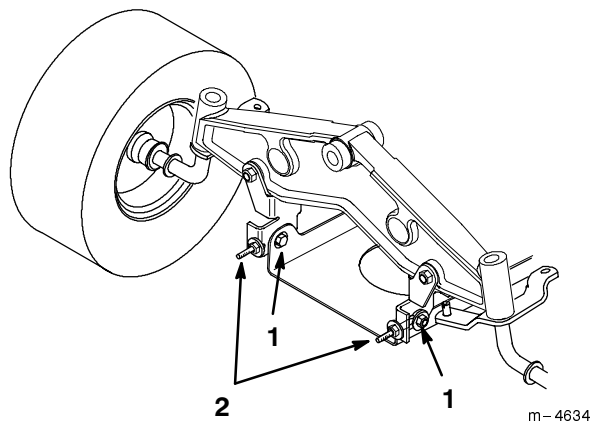

Figure 49

- | | |
|-------------------------|------------------------|
| 1. Measure front center | 2. Measure rear center |
|-------------------------|------------------------|

7. To adjust front-to-rear blade slope loosen front pivot plate mounting bolts slightly (Fig. 50).
8. Rotate lock nuts on eyebolts to change adjustment (Fig. 50). To raise the front of the mower, tighten the eyebolt lock nuts. To lower the front of the mower, loosen the eyebolt lock nuts.
9. After adjusting both eyebolt lock nuts evenly, check the front-to-rear slope again. Continue adjusting eyebolts until the front blade tip is 0-3/8" (0-9.2 mm) lower than the rear blade tip (Fig. 50).

10. When front-to-rear slope is correct, tighten the pivot plate mounting bolts (Fig. 50).

**Figure 50**

1. Pivot mounting bolt
2. Eyebolt locknut

11. When front-to-rear slope is correct, recheck the side-to-side level of the mower; refer to Side-to-Side Mower Leveling, page 40.

Washing Underside of Mower

After each use wash the underside of the mower to prevent grass build-up for improved mulch action and clipping dispersal.

1. Park the machine on a hard, level surface, disengage the power take off (PTO) and turn the ignition key to “OFF” to stop the engine.
2. Attach coupling (not supplied) to mower washout fitting and turn water on high (Fig. 51).
3. Lower the mower to the lowest height-of-cut.
4. Sit on the seat and start the engine. Engage power take off (PTO) and let mower run for one to three minutes.
5. Disengage the power take off (PTO) and turn the ignition key to “OFF” to stop the engine.
6. Turn the water off, remove coupling from the washout fitting and hose.
7. Run mower again for one to three minutes to remove excess water.

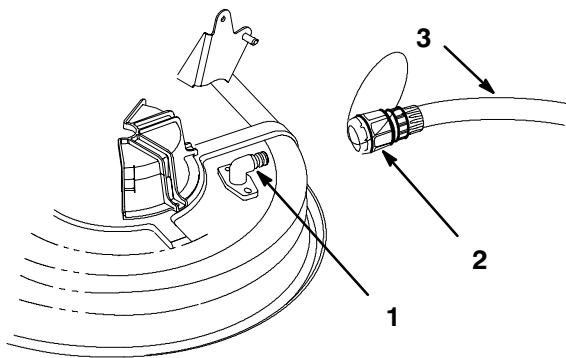

Figure 51

1. Washout fitting
2. Coupling
3. Hose

WARNING

POTENTIAL HAZARD

- A broken or missing washout fitting could expose you and others to thrown objects or blade contact.

WHAT CAN HAPPEN

- Contact with thrown debris or blade contact will cause injury or death.

HOW TO AVOID THE HAZARD

- Replace broken or missing washout fitting immediately, before using mower again.
- Plug any hole(s) in mower with bolts and locknuts.
- Never put your hands or feet under the mower or through openings in the mower.

Cleaning and Storage

1. Disengage the power take off (PTO), set the parking brake, and turn the ignition key to “OFF” to stop the engine. Remove the key.
2. Remove grass clippings, dirt, and grime from the external parts of the entire machine, especially the engine. Clean dirt and chaff from the outside of the engine’s cylinder head fins and blower housing.

IMPORTANT: You can wash the machine with mild detergent and water. **DO NOT PRESSURE WASH THE MACHINE.** Pressure washing may damage the electrical system or wash away necessary grease at friction points. Avoid excessive use of water, especially near the control panel, lights, engine, and the battery.

m-2921

3. Check the brake; refer to Brake, page 24.
4. Service the air cleaner; refer to Air Cleaner, page 31.
5. Grease the chassis; refer to Greasing and Lubrication, page 23.

6. Change the crankcase oil and filter; refer to Engine Oil, page 33.
7. Check the tire pressure; refer to Tire Pressure, page 23.
8. Prepare the machine for storage when non-use occurs over 30 days. Prepare machine for storage as follows.

- A. Add a petroleum based stabilizer/conditioner to fuel in the tank. Follow mixing instructions from stabilizer manufacture. (1 oz. per gallon). **Do not use an alcohol based stabilizer (ethanol or methanol).**

Note: A fuel stabilizer/conditioner is most effective when mixed with fresh gasoline and used at all times.

- B. Run engine to distribute conditioned fuel through the fuel system (5 minutes).
- C. Stop engine, allow to cool and drain the fuel tank; refer to Fuel Tank, page 30.
- D. Restart engine and run it until it stops.
- E. Choke or prime the engine. Start and run engine until it will not start. Operate primer, if equipped on machine, several times to ensure no fuel remains in primer system.
- F. Dispose of fuel properly. Recycle as per local codes.

IMPORTANT: Do not store stabilizer/conditioned gasoline over 90 days.

9. Remove the spark plug(s) and check its condition; refer to Spark Plug, page 29. With the spark plug(s) removed from the engine, pour two tablespoons of engine oil into the spark plug hole. Now use the electric starter to crank the engine and distribute the oil inside the cylinder. Install the spark plug(s); refer to Spark Plug, page 29. Do not install the wire on the spark plug(s).

10. Remove the battery from the chassis, check the electrolyte level, and charge it fully; refer to Battery, page 27. Do not connect the battery cables to the battery posts during storage.

IMPORTANT: The battery must be fully charged to prevent it from freezing and being damaged at temperatures below 32°F (0°C). A fully charged battery maintains its charge for about 50 days at temperatures lower than 40°F (4°C). If the temperatures will be above 40°F (4°C), check the water level in the battery and charge it every 30 days.

11. Check and tighten all bolts, nuts, and screws. Repair or replace any part that is damaged or defective.
12. Paint all scratched or bare metal surfaces. Paint is available from your Authorized Service Dealer.
13. Store the machine in a clean, dry garage or storage area. Remove the key from the ignition switch and keep it in a memorable place. Cover the machine to protect it and keep it clean.

Troubleshooting

PROBLEM	POSSIBLE CAUSES	CORRECTIVE ACTION
Starter does not crank	<ol style="list-style-type: none"> 1. Blade control (PTO) is ENGAGED. 2. Parking brake is not on. 3. Battery is dead. 4. Electrical connections are corroded or loose. 5. Fuse is blown. 6. Relay or switch is defective. 	<ol style="list-style-type: none"> 1. Move blade control (PTO) to DISENGAGED. 2. Set parking brake. 3. Charge the battery. 4. Check electrical connections for good contact. 5. Replace fuse. 6. Contact Authorized Service Dealer.
Engine will not start, starts hard, or fails to keep running.	<ol style="list-style-type: none"> 1. Operator is not seated. 2. Fuel tank is empty. 3. Air cleaner is dirty. 4. Spark plug wire is loose or disconnected. 5. Spark plug is pitted, fouled, or gap is incorrect. 6. Choke is not closing. 7. Dirt in fuel filter. 8. Idle speed is too low or mixture is incorrect. 9. Dirt, water, or stale fuel is in fuel system. 	<ol style="list-style-type: none"> 1. Sit on the seat. 2. Fill fuel tank with gasoline. 3. Clean or replace air cleaner element. 4. Install wire on spark plug. 5. Install new, correctly gapped spark plug. 6. Adjust throttle cable. 7. Replace fuel filter. 8. Adjust carburetor idle speed and idle mixture. 9. Contact Authorized Service Dealer.
Engine loses power.	<ol style="list-style-type: none"> 1. Engine load is excessive. 2. Air cleaner is dirty. 3. Oil level in crankcase is low. 4. Cooling fins and air passages under engine blower housing are plugged. 5. Spark plug is pitted, fouled, or gap is incorrect. 6. Vent hole in fuel cap is plugged. 7. Dirt in fuel filter. 8. Dirt, water, or stale fuel is in fuel system. 	<ol style="list-style-type: none"> 1. Reduce ground speed. 2. Clean air cleaner element. 3. Add oil to crankcase. 4. Remove obstruction from cooling fins and air passages. 5. Install new, correctly gapped spark plug. 6. Clean or replace the fuel cap. 7. Replace fuel filter. 8. Contact Authorized Service Dealer.

PROBLEM	POSSIBLE CAUSES	CORRECTIVE ACTION
Engine over heats.	<ol style="list-style-type: none"> 1. Engine load is excessive. 2. Oil level in crankcase is low. 3. Cooling fins and air passages under engine blower housing are plugged. 	<ol style="list-style-type: none"> 1. Reduce ground speed. 2. Add oil to crankcase. 3. Remove obstruction from cooling fins and air passages.
Abnormal vibration.	<ol style="list-style-type: none"> 1. Cutting blade(s) is bent or unbalanced. 2. Blade mounting bolt is loose. 3. Engine mounting bolts are loose. 4. Loose engine pulley, idler pulley, or blade pulley. 5. Engine pulley is damaged. 	<ol style="list-style-type: none"> 1. Install new cutting blade(s). 2. Tighten blade mounting bolt. 3. Tighten engine mounting bolts. 4. Tighten the appropriate pulley. 5. Contact Authorized Service Dealer.
Blade(s) does not rotate.	<ol style="list-style-type: none"> 1. Blade drive belt is worn, loose or broken. 2. Blade drive belt is off pulley. 	<ol style="list-style-type: none"> 1. Install new blade drive belt. 2. Install blade drive belt and check idler pulley and belt guides for correct position.
Machine does not drive.	<ol style="list-style-type: none"> 1. Drive control is in "PUSH" position. 2. Traction belt is worn, loose or broken. 3. Traction belt is off pulley. 	<ol style="list-style-type: none"> 1. Move drive control to "OPERATE" position. 2. Contact Authorized Service Dealer. 3. Contact Authorized Service Dealer.
Uneven cutting height.	<ol style="list-style-type: none"> 1. Tire pressure is incorrect. 2. Mower is not level. 3. Underside of mower is dirty. 	<ol style="list-style-type: none"> 1. Set tire pressure. 2. Level mower from side-to-side and front-to-rear. 3. Clean the underside of the mower.



Consumer
Riding
Products

The Toro Total Coverage Guarantee

A Two-Year Full Warranty
(Limited Warranty for Commercial Use)

Conditions and Products Covered

The Toro Company and its affiliate, Toro Warranty Company, pursuant to an agreement between them, jointly promise to repair any Toro Product used for normal residential purposes* if defective in materials or workmanship. The following time periods apply from the date of purchase:

<u>Products</u>	<u>Warranty Period</u>
• All Products	2 year full warranty
• 300 and 5xi Series Tractors:	
Chassis	5 year full warranty
Front Axle	5 year full warranty
Drive Shaft (5xi Series Only)	5 year full warranty
• All Batteries	1 year full warranty

This warranty covers both the cost of parts and labor, and transportation within a fifteen mile radius of the servicing dealer.

This warranty applies to all consumer riding products and their attachments.

* Normal residential purposes means use of the product on the same lot as your home. Use at more than one location is considered commercial use, and the commercial use warranty would apply.

Limited Warranty for Commercial Use

Toro Consumer Products and attachments used for commercial, institutional, or rental use are warranted against defects in materials or workmanship for the following time periods from the date of purchase:

<u>Products</u>	<u>Warranty Period</u>
• All Products	90 day limited warranty
• 300 and 5xi Series Tractors:	
Chassis	1 year limited warranty
Liquid Cooled Gas Engines	1 year limited warranty
Air Cooled Gas and Diesel Engines	2 year limited warranty

Instructions for Obtaining Warranty Service

Should you feel your Toro Product contains a defect in materials or workmanship, contact the retailer who sold you the product or any Authorized Service Dealer or Master Service Dealer. The Yellow Pages of your telephone directory is a good reference source. The dealer will either arrange service at his/her dealership or recommend another Authorized Service Dealer who may be more convenient. You may need proof of purchase (copy of registration card, sales receipt, etc.) for warranty validation.

Countries Other than the United States or Canada

Customers who have purchased Toro products exported from the United States or Canada should contact their Toro Distributor (Dealer) to obtain guarantee policies for your country, province, or state. If for any reason you are dissatisfied with your Distributor's service or have difficulty obtaining guarantee information, contact the Toro importer. If all other remedies fail, you may contact us at Toro Warranty Company.

If for any reason you are dissatisfied with the Service Dealer's analysis of the defect in materials or workmanship or if you need a referral to a Toro Service Dealer, please feel free to contact us at:

Customer Service Department
Toro Warranty Company
8111 Lyndale Avenue South
Bloomington, MN 55420-1196
612-888-8801
800-348-2424

Owner Responsibilities

You must maintain your Toro Product by following the maintenance procedures described in the operator's manual. Such routine maintenance, whether performed by a dealer or by you, is at your expense.

Items and Conditions Not Covered

There is no other express warranty except for special emission system coverage on some products. This express warranty does not cover:

- Cost of regular maintenance service or parts, such as filters, fuel, lubricants, tune-up parts, blade sharpening, brake and clutch adjustments.
- Any product or part which has been altered or misused or required replacement or repair due to normal wear, accidents, or lack of proper maintenance.
- Repairs necessary due to improper fuel, contaminants in the fuel system, or failure to properly prepare the fuel system prior to any period of non-use over three months.
- Pickup and delivery charges for distances beyond a fifteen mile radius from an Authorized Toro Service Dealer.

All repairs covered by this warranty must be performed by an Authorized Toro Service Dealer using Toro approved replacement parts.

General Conditions

Repair by an Authorized Toro Service Dealer is your sole remedy under this warranty.

Neither The Toro Company nor Toro Warranty Company is liable for indirect, incidental or consequential damages in connection with the use of the Toro Products covered by this warranty, including any cost or expense of providing substitute equipment or service during reasonable periods of malfunction or non-use pending completion of repairs under this warranty. Some states do not allow exclusions of incidental or consequential damages, or limitations on how long an implied warranty lasts, so the above exclusions and limitations may not apply to you.

This warranty gives you specific legal rights, and you may also have other rights which vary from state to state.