



**Wheel Horse<sup>®</sup>**  
**518xi Garden Tractor**  
**520xi Garden Tractor**  
**520xi Euro Garden Tractor**

**Model No. 73471-200000001 and Up**

**Model No. 73542-200000001 and Up**

**Model No. 73570-200000001 and Up**

## Parts Catalog

### Ordering Replacement Parts

To order replacement parts, please supply: the part number, the quantity, and the description of each part desired.

### Understanding Reference Numbers

Each identified part in an illustration has a reference number. The reference number for a part also appears in the parts list, along with other information about the part.

This catalog uses two special reference number formats, one to indicate parts in a service assembly and another to indicate the quantity of a given part in an illustration.

### Service Assembly Reference Numbers

Parts in service assemblies have reference numbers in the form **a:b**. The **a** represents the reference number of the entire service assembly and the **b** represents a sequential number unique to each part within the service assembly.

For example, a wheel assembly might be identified by reference number **6**, the tire by **6:1**, the valve by **6:2**, and the wheel by **6:3**. When you order the assembly identified by reference number **6**, you receive all parts identified by reference numbers **6:1**, **6:2**, and **6:3**. However, you may also order any part individually.

Reference numbers of this type appear in illustrations and in part lists.

### Reference Numbers Indicating Quantity

In an illustration, if a reference number indicates more than one part, the reference number has the form **nX y**. The **n** represents the quantity of the part, the **X** is the multiplication symbol, and the **y** represents the reference number.

For example, in an illustration, the reference number **2X 37** means that two of the parts identified by reference number **37** are indicated.

## Contents

Description	Page
Bumper & Hood Support Assembly	3
Steering Tower & Fuel Tank Support Assembly	4
Attach–A–Matic & Hitch Assembly	5
Lower Manual Steering Assembly	6
Manual Steering & Tilt Assembly	7
Tie Rods, Spindle, & Front Axle Assembly	8
Hydro Transaxle Assembly	9
Hydro Transaxle Assembly	10
Transmission Assembly	11–12
Drive Shaft Assembly	13
Lower Hydro Lift Assembly	14
Upper Hydro Lift Assembly	15
Hood & Headlight Assembly	16
Grille & Side Panels Assembly	17
Dash Assembly	18
Fender, Footrest, & Seat Assembly	19–20
Rear Smart Turn Assembly	21

Description	Page
Hi–Lo Shift Assembly	22
Upper Parking Brake Assembly	23
Hydro Controls Assembly	24
Front Smart Turn Assembly	25
Lower Parking Brake Assembly	26
Cruise Control Assembly	27
Fender & Fuel System Assembly	28
Wheel Assembly	29
Air Cooled Engine Assembly	30–31
Electrical Assembly (Model No. 73471 Only)	32
Electrical Assembly (Model Nos. 73542, & 73570 Only)	33–34
Electrical	35–38
Engine 18HP	39–49
Engine 20HP	50–60
Maintenance	61–63

## Accessories

Description	Model / Part No.
42" Rear Discharge Mower (Model No. 73471 & 73542 Only)	78353
42" Rear Discharge Low Cut Mower (Model No. 73570 Only)	78442
44" Side Discharge Mower (Model No. 73471 & 73542 Only)	78357
44" Side Discharge Low Cut Mower (Model No. 73570 Only)	78444
48" Side Discharge Mower (Model No. 73471 & 73542 Only)	78363
48" Side Discharge Low Cut Mower (Model No. 73570 Only)	78448
52" Side Discharge Mower (Model No. 73471 & 73542 Only)	78370

Description	Model / Part No.
52" Side Discharge Low Cut Mower (Model No. 73570 Only)	78452
60" Side Discharge Mower (Model No. 73471 & 73542 Only)	78395
60" Side Discharge Low Cut Mower (Model No. 73570 Only)	78469
36" Tiller*	79375
50" Grader Blade*	79356
42" Single Stage Snowthrower**	79365
44" Two–Stage Snowthrower**	79366
48" Snow/Dozer Blade**	79355

\*\* Requires 81115

## Part Description Abbreviations

Part descriptions in this catalog may include the following abbreviations.

Abbreviation	Meaning
HOC	height-of-cut
HS	hex socket
HSBH	hex socket button head
AR	as required
ASM	assembly
CARR	carriage
DEG	degrees
FH	flat head
GA	gauge
HF	hex flange
HWH	hex washer head
HH	hex head
HHF	hex head flange
HLH	hex lag head
HJ	hex jam
HSFH	hex socket flat head
HSH	hex socket head
HWHTF	hex washer head thread forming

Abbreviation	Meaning
INC	incorporated
LH	left hand
NI	nylon insert
PPH	Phillips pan head
PTH	Phillips truss head
PTO	power take off
RH	right hand
SFH	slotted fillister head
SHH	slotted hex head
SQH	square head
SHWH	slotted hex washer head
SPH	slotted pan head
SRH	slotted round head
STD	standard
TAP	self tapping
TTH	Torx truss head
WH	wing head

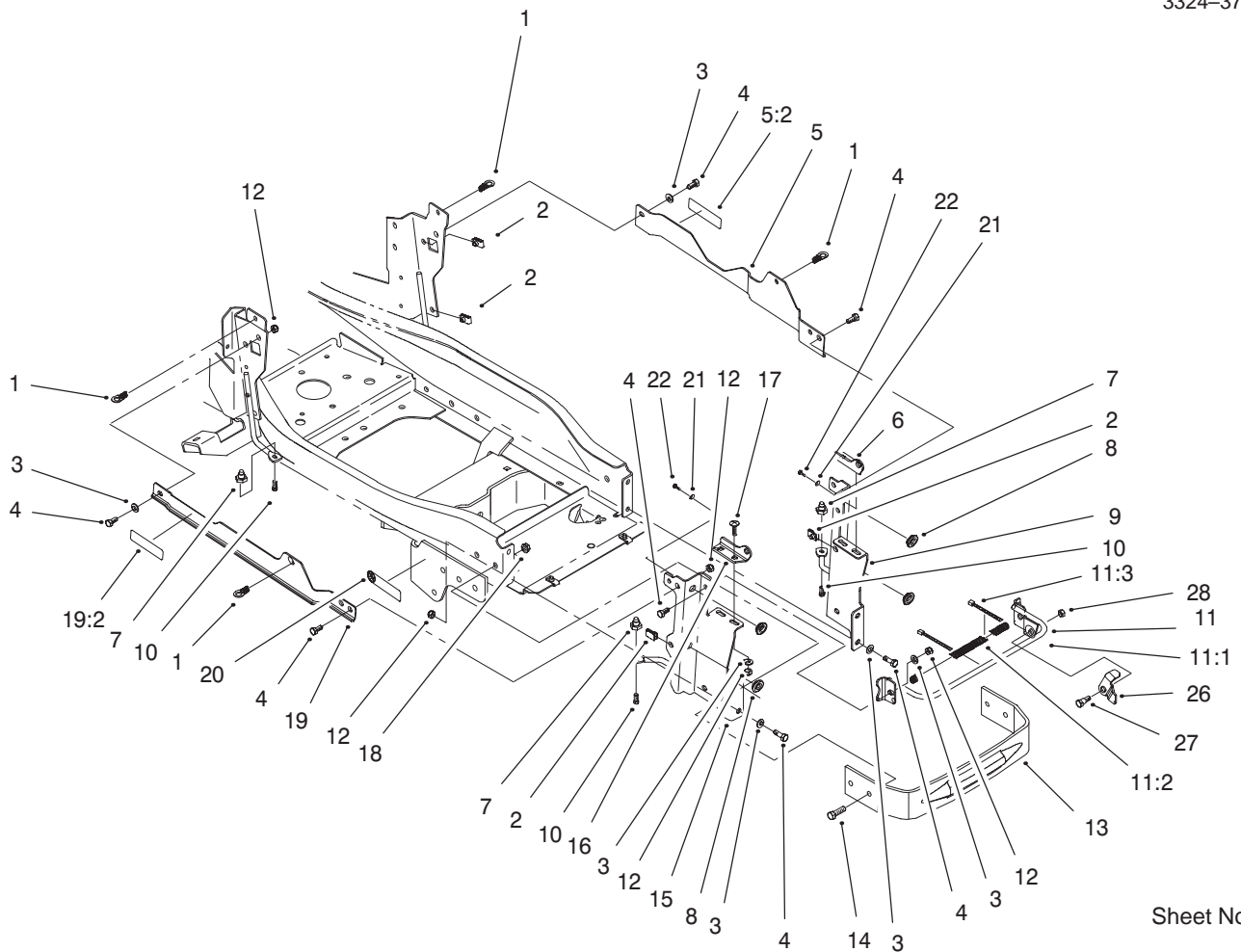

Sheet No.:3

## Bumper & Hood Support Assembly

Ref. No.	Part No.	Qty.	Description
1	95-4013	4	Assembly-Latch
2	107069	6	Clip
3	3256-23	12	Washer-Flat
4	322-3	12	Screw-HH
5	98-5064	1	ASM - Support w/Decal (only on: 73471, 73542)
5	98-5070	1	ASM - Support w/Decal (only on: 73570)
5:2	98-5015	1	Decal - Warning (only on: 73570)
5:2	98-5014	1	Decal - Warning (only on: 73471, 73542)
6	98-9026-03	1	Brkt-Hinge Lower LH
7	95-3989	4	Mount-Sidepanel
8	94-7910	4	Grommet
9	95-4082-03	1	Wa-Hood Sprt LH
10	46-8093	4	Screw-Plastite
11	99-5305	1	Support-Hood ASM
11:1	98-9017-03	1	Hood Support Brace W.a.
11:2	95-4258	1	Cover - Brace
11:3	614249	2	Tie Strap
12	3296-29	16	Nut-Lock, NI
13	94-2308-03	1	Bumper - Frame

Ref. No.	Part No.	Qty.	Description
14	323-7	4	Screw-HH
15	95-4081-03	1	Wa-Hood Sprt RH
16	98-9027-03	1	Brkt-Hinge Lower RH
17	3230-16	4	Screw-HH
18	3296-39	4	Nut-Lock, NI
19	99-5344	1	ASM Support/Decal (only on: 73570)
19	99-5345	1	ASM-Support/Decal (only on: 73471, 73542)
19:2	98-5014	1	Decal - Warning (only on: 73471, 73542)
19:2	98-5015	1	Decal - Warning (only on: 73570)
20	92-8747	2	Decal Attach-A-Matic
21	3256-61	2	Washer-Flat (only on: 73570)
22	32144-42	2	Screw-Selftap (only on: 73570)
26	98-9015	1	Lever - Hood Prop
27	37-8771	1	Bolt-Shoulder
28	3296-47	1	Nut-Lock, NI

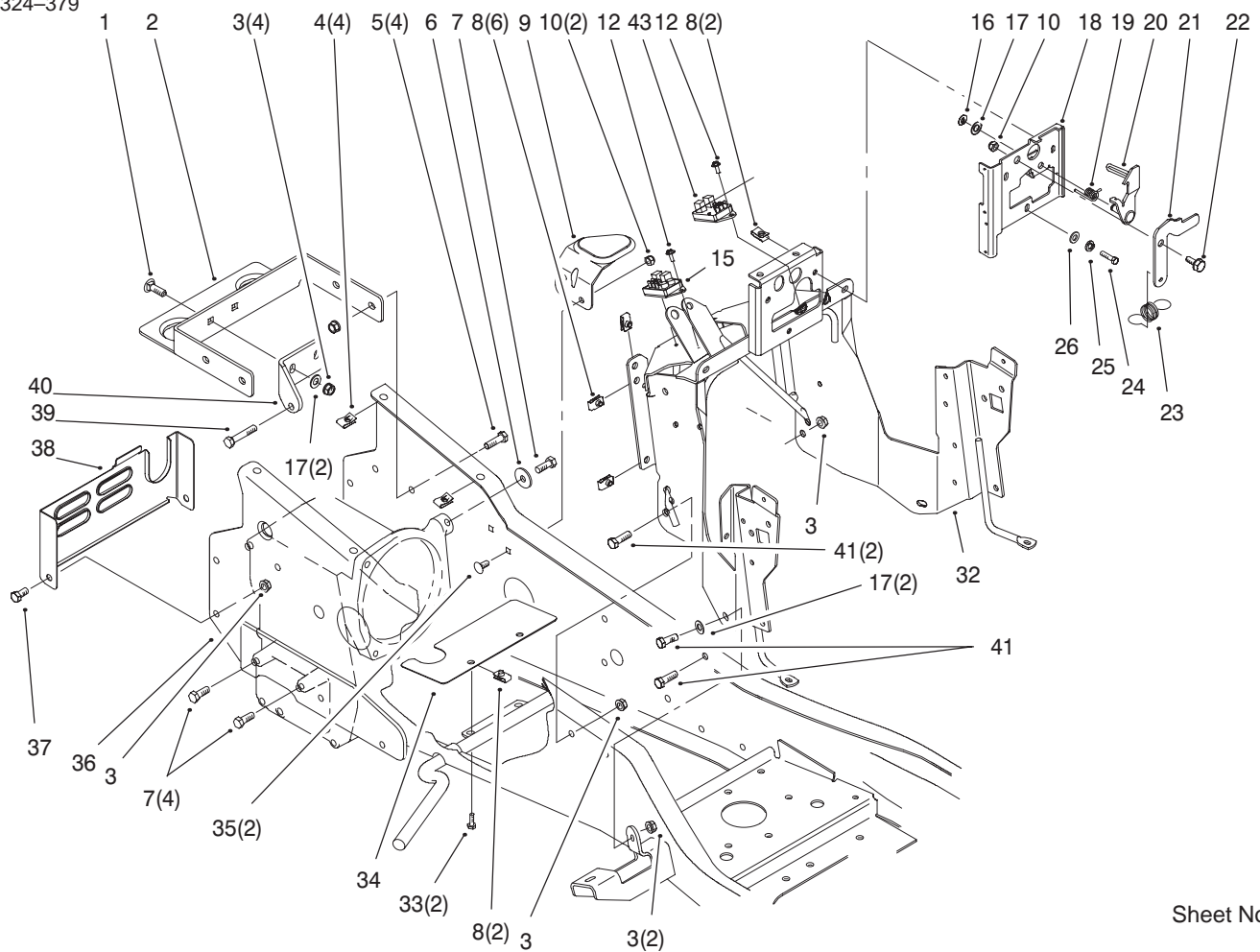

Sheet No.:4

## Steering Tower & Fuel Tank Support Assembly

Ref. No.	Part No.	Qty.	Description
1	3231-25	2	Screw-CARR
2	94-7740-03	1	Support-Gas Tank
3	3296-39	10	Nut-Lock, NI
4	94-2413	4	U-Nut
5	323-7	4	Screw-HH
6	2844	1	Washer
7	3235-22	5	Screw-HH
8	107069	10	Clip
9	95-3961-03	1	Support - Fuel Tank
10	3296-29	3	Nut-Lock, NI
12	12-5450	2	Screw (only on: 73542, 73570)
12	12-5450	1	Screw (only on: 73471)
15	99-3703	1	Module-Cruise (only on: 73542, 73570)
16	105797	1	Ring-Retaining
17	3256-24	5	Washer-Flat
18	95-3892-03	1	Bracket - Latch
19	95-4165	1	Spring - Latch Lever
20	95-3899	1	Wa - Latch Lever
21	95-3900	1	Latch - Tension Lever
22	37-8771	1	Bolt-Shoulder
23	95-3895	1	Spring - Latch Lever
24	321-4	3	Screw-HH
25	3253-3	3	Washer-Lock/Sp

Ref. No.	Part No.	Qty.	Description
26	3256-22	3	Washer-Flat
32	99-4441-03	1	Tower ASM-Welded
33	321-4	2	Screw-HH
34	95-4246	1	Baffle - Fan
35	3230-20	2	Screw-CARR
36	99-5306-03	1	Frame Wa
37	323-4	2	Screw-HH
38	95-4005-03	1	Cover - Rear
39	94-7972	1	Screw - HH
40	94-7739-03	1	Strap-Torque
41	323-6	4	Screw-HH
43	99-3701	1	Module-Nmir, Clutch

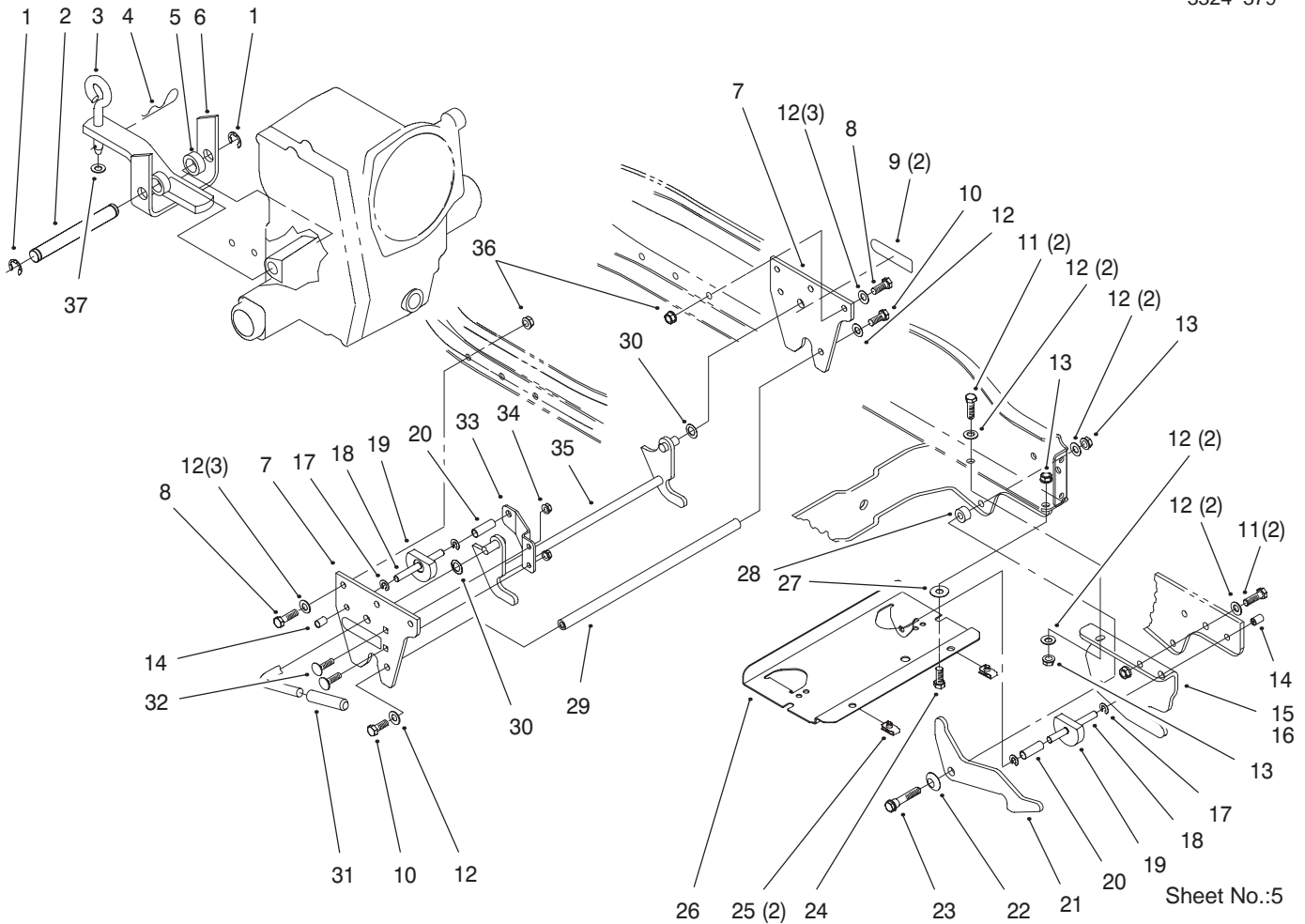

## Attach-A-Matic & Hitch Assembly

Ref. No.	Part No.	Qty.	Description
1	5618	2	E-Ring
2	105269	1	Pin-Stationary Hitch
3	106634	1	Pin-Tool
4	9335054	1	Pin-Hair
5	9791204	2	Spacer
6	98-8083-03	1	Hitch Wa
7	94-2251-03	2	Plate - Hitch
8	323-44	6	Screw-HH
9	98-1632	2	Decal - Attach-A-Matic
10	3235-22	2	Screw-HH
11	323-7	4	Screw-HH
12	3256-24	16	Washer-Flat
13	3296-39	8	Nut-Lock, NI
14	105316	3	Cap-Plunger Rod
15	94-2230-03	1	Hanger - RH
16	94-2231-03	1	Hanger - LH
17	105797	6	Ring-Retaining
18	94-2256	3	Rod - Lock
19	94-2258	3	Lock - Latch
20	8616	3	Spring
21	94-7777	2	Latch-Pulley Box
22	3290-221	2	Washer-Spring
23	92-7674	2	Bolt
24	323-6	2	Screw-HH
25	107069	2	Clip

Ref. No.	Part No.	Qty.	Description
26	94-2304-03	1	Tray - Battery
27	3-4685	2	Washer-Top Thrust
28	94-2233	2	Spacer
29	94-2475	1	Rod - Spacer
30	98-1629	2	Washer
31	9038	1	Grip
32	3230-2	2	Screw-CARR
33	94-7855-03	1	Brkt-Mid Aam
34	3296-29	2	Nut-Lock, NI
35	94-2250-03	1	Wa - Latch
36	108881	6	Nut-Differential
37	3256-26	1	Washer-Flat



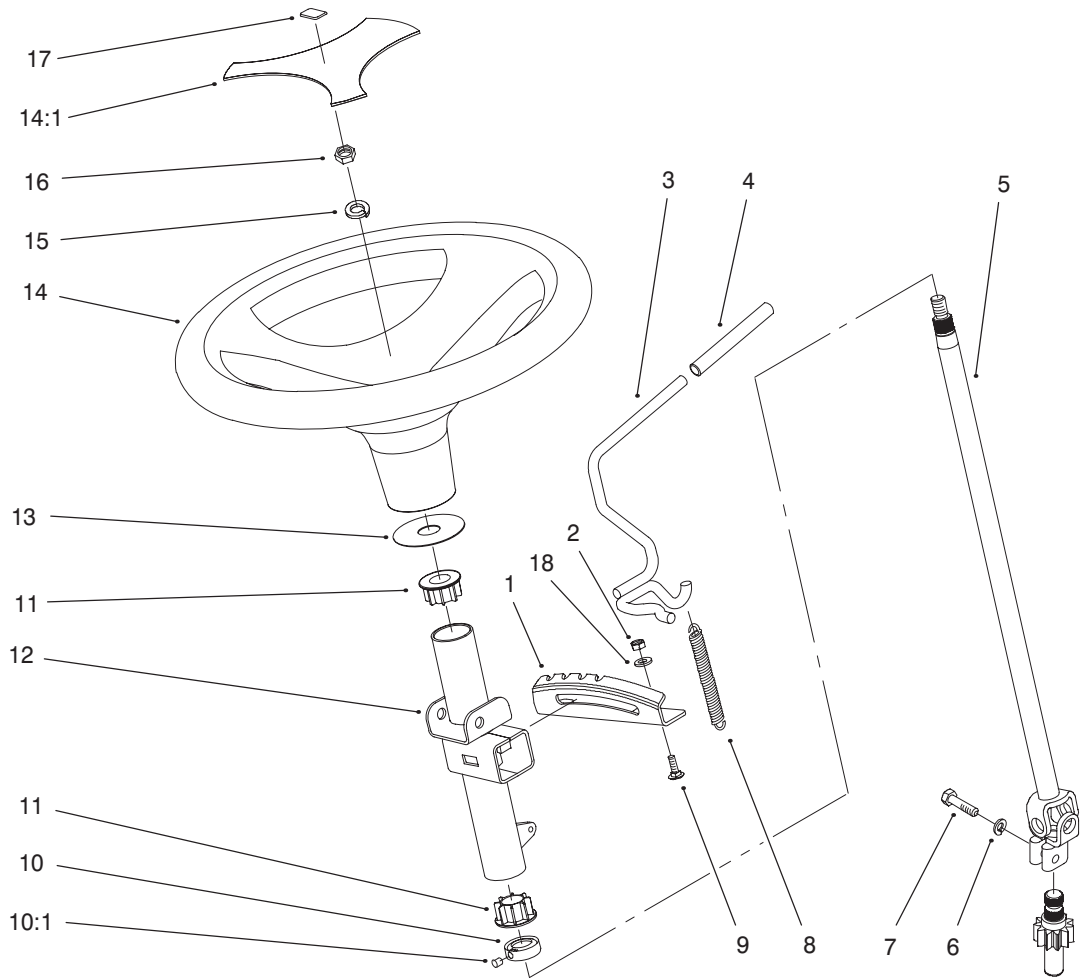

Sheet No.:7

## Manual Steering & Tilt Assembly

Ref. No.	Part No.	Qty.	Description
1	94-2382	1	Bracket – Detent
2	3296-42	2	Nut–Lock
3	95-3964	1	Wa – Tilt Lever
4	92-6798	1	Cap – Rod Tilt
5	94-2047	1	Shaft – Steering
6	3253-4	1	Washer
7	48-7730	1	Screw–HH
8	95-3805	1	Spring
9	3229-1	2	Screw–CARR
10	111383	1	Collar
10:1	3245-32	1	Screw–HS
11	93-1146	2	Bushing – Upper Strg
12	94-2450-03	1	Wa– Manual Column
13	94-2025	1	Washer – Boot
14	98-1471	1	Wheel – Steering 14” (only on: 73471)
14	98-7211	1	Assembly – Cover (Service)
14	98-1474	1	Wheel – Steering 15”, Soft (only on: 73542, 73570)
14:1	98-1468	1	Cover – Wheel, Steering (only on: 73471)
15	48-8070	1	Washer–Lock
16	3277-1	1	Nut–Hex

Ref. No.	Part No.	Qty.	Description
17	98-1459	1	Decal–Toro
18	3256-22	2	Washer–Flat

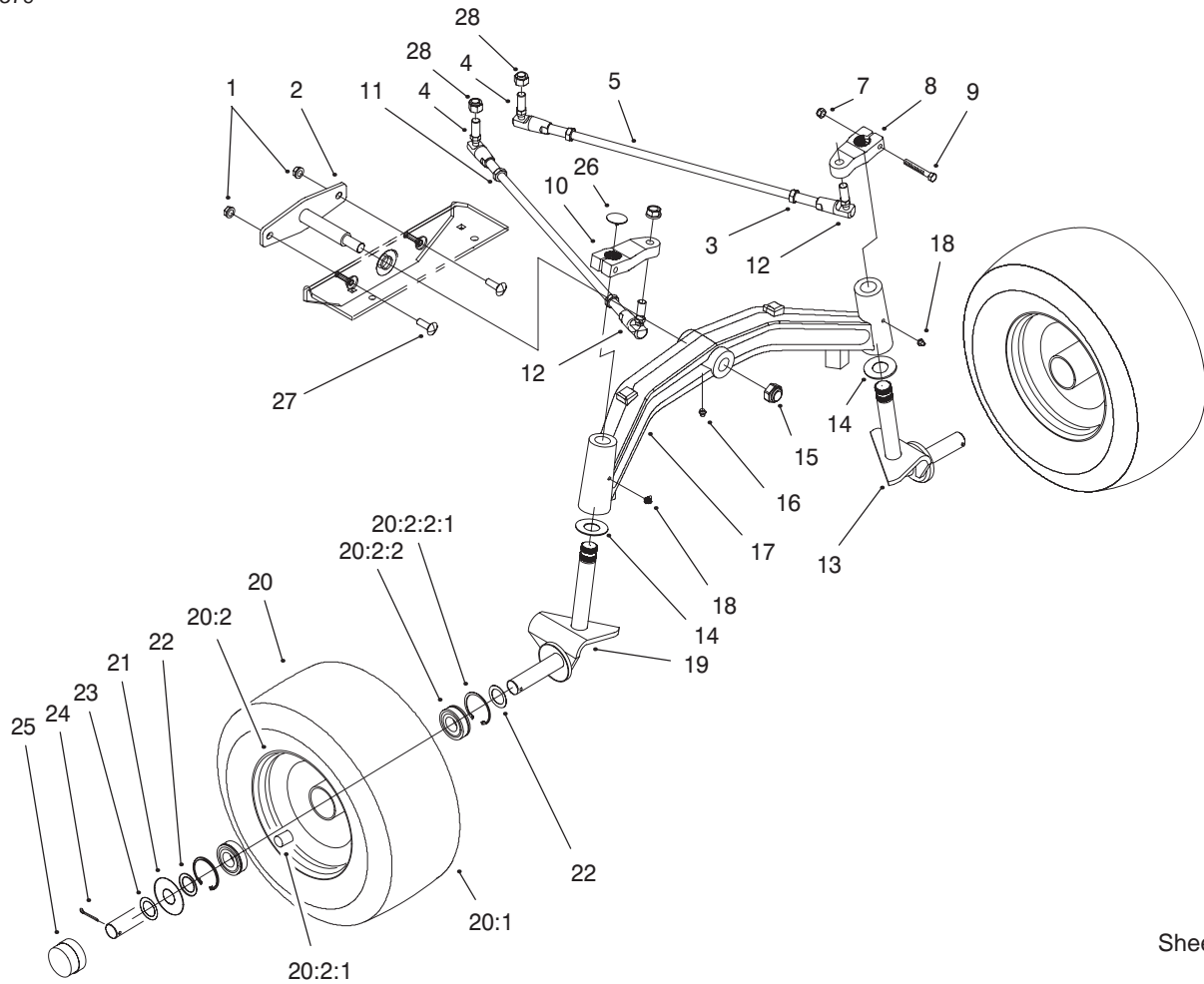

Sheet No.:14

## Tie Rods, Spindle, & Front Axle Assembly

Ref. No.	Part No.	Qty.	Description
1	3296-39	2	Nut-Lock, NI
2	94-2205-03	1	Wa - Pivot Pin
3	3220-5	2	Nut-Hex Jam
4	94-2239	2	Balljoint - LH Thread (only on: 73471)
4	94-7539	2	Balljoint - LH Thread (only on: 73542, 73570)
5	100-1121	2	Rod-Tie
7	3296-29	2	Nut-Lock, NI
8	94-2197	1	Arm - Steering LH
9	322-32	2	Screw-HH
10	94-2196	1	Arm - Steering RH
11	3220-12	2	Nut-Jam, LH Thread
12	98-8087	2	Balljoint - RH Thread (only on: 73471)
12	98-8086	2	Balljoint - RH Thread (only on: 73542, 73570)
13	94-7537-03	1	Wa - LH Spindle
14	9548	2	Washer-Thrust
15	3296-61	1	Nut-Lock
16	302-5	1	Fitting-Lube
17	94-7568-03	1	Axle-Front 25mm
18	302-5	2	Fitting-Lube
19	94-7536-03	1	Wa-RH Spindle

Ref. No.	Part No.	Qty.	Description
20	99-3695	2	Wheel & Tire ASM, Toro
20:1	99-3696	1	Tire
20:2	94-7541	1	Rim ASM, Toro
20:2:1	5108	1	Valve-Tubeless Tire
20:2:2	94-7538	2	Bearing
20:2:2:1	94-2053	1	Ring-Snap
*	112819	1	Tube-Inner
21	95-4060	2	Washer - Wheel
22	9202514	4	Washer
23	9202524	2	Washer
24	3272-18	2	Pin-Cotter
25	94-7871	2	Cap - Dust
26	98-1642	2	Cap - Spindle
27	3231-25	2	Screw-CARR
28	98-8089	4	Nut-Esna

\* Not illustrated

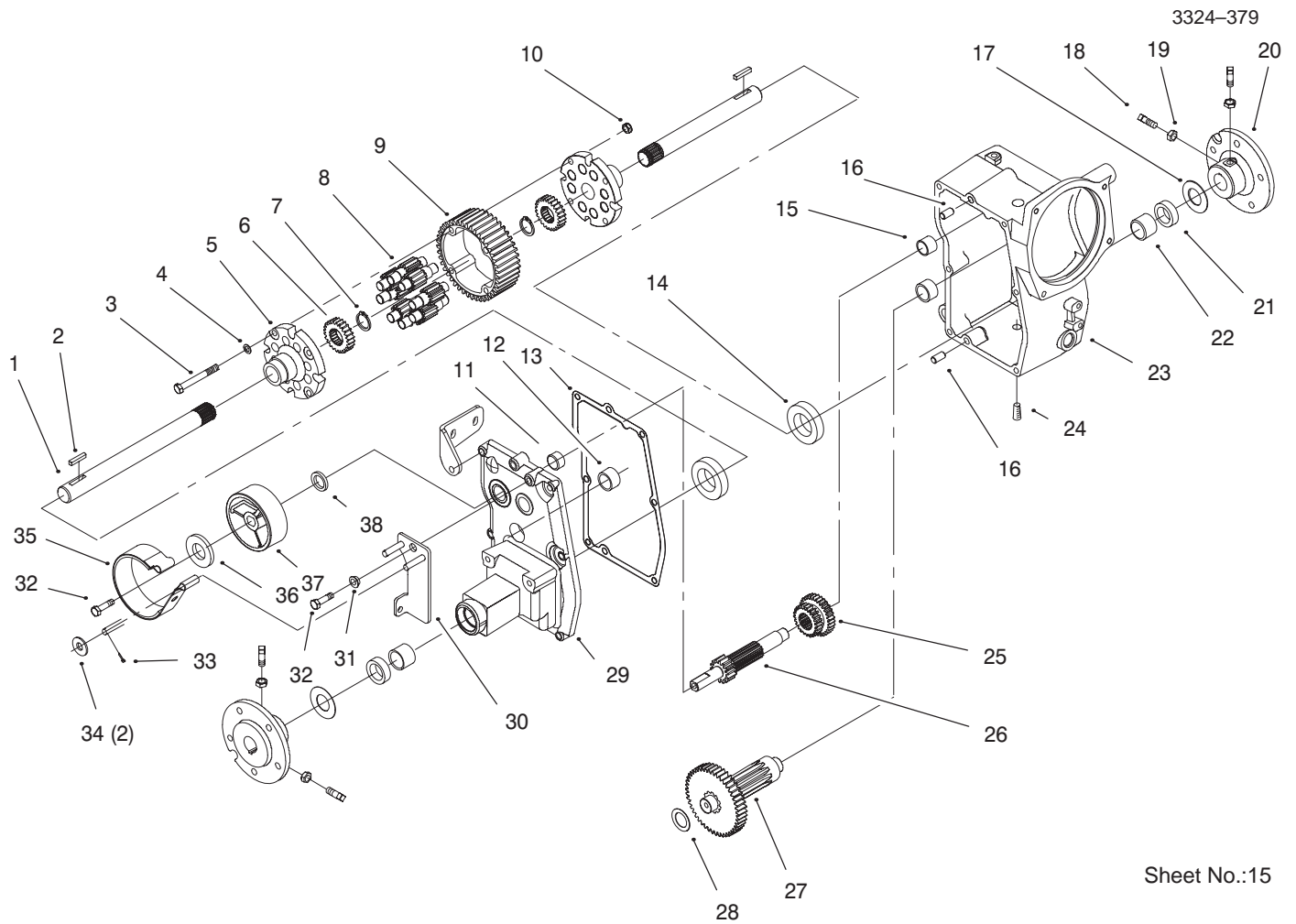

Sheet No.:15

## Hydro Transaxle Assembly

Ref. No.	Part No.	Qty.	Description
1	79-3340	2	Axle-Rear (11.62)
2	79-3370	2	Key
3	911423	4	Bolt-Hex
4	107374	4	Washer
5	111196	2	End Cap-Differential
6	101889	2	Gear-Axle Differential
7	105876	2	Ring-Snap
8	101623	8	Gear-Pinion 11t
9	105061	1	Gear-Differential Ring 43t
10	108881	4	Nut-Differential
11	1540	1	Bearing-Needle
12	94-2021	2	Bearing - Needle
13	99-5334	1	Gasket-Case
14	111199	2	Bearing-Ball
15	1529	1	Bearing-Needle
16	108363	2	Pin-Locating
17	106826	2	Washer-Thrust
18	3243-5	4	Screw-Set
19	3218-3	4	Nut-Jam
20	105763-03	2	Hub-Whl(5blt1-1/8
21	6449	2	Seal-Oil
22	9416	2	Bearing
23	94-2001-03	1	Case-LH-Trans
24	99-8551	1	Plug-Pipe
25	94-2008	1	Gear - Sliding

Ref. No.	Part No.	Qty.	Description
26	94-2007	1	Shaft - Brake
27	94-2006	1	Assembly - Gear
28	9547	1	Washer-Thrust
29	94-2002-03	1	Case-RH-Trans
30	94-2019-03	1	Wa-Brake Pivot Arm
31	100309	1	Cam-Spacer
32	3235-22	2	Screw-HH
33	3272-6	2	Pin-Cotter
34	3256-24	2	Washer-Flat
35	94-2419	1	Band - Brake
36	2844	1	Washer
37	94-2009	1	Drum - Brake
38	253-44	1	Seal-Oil

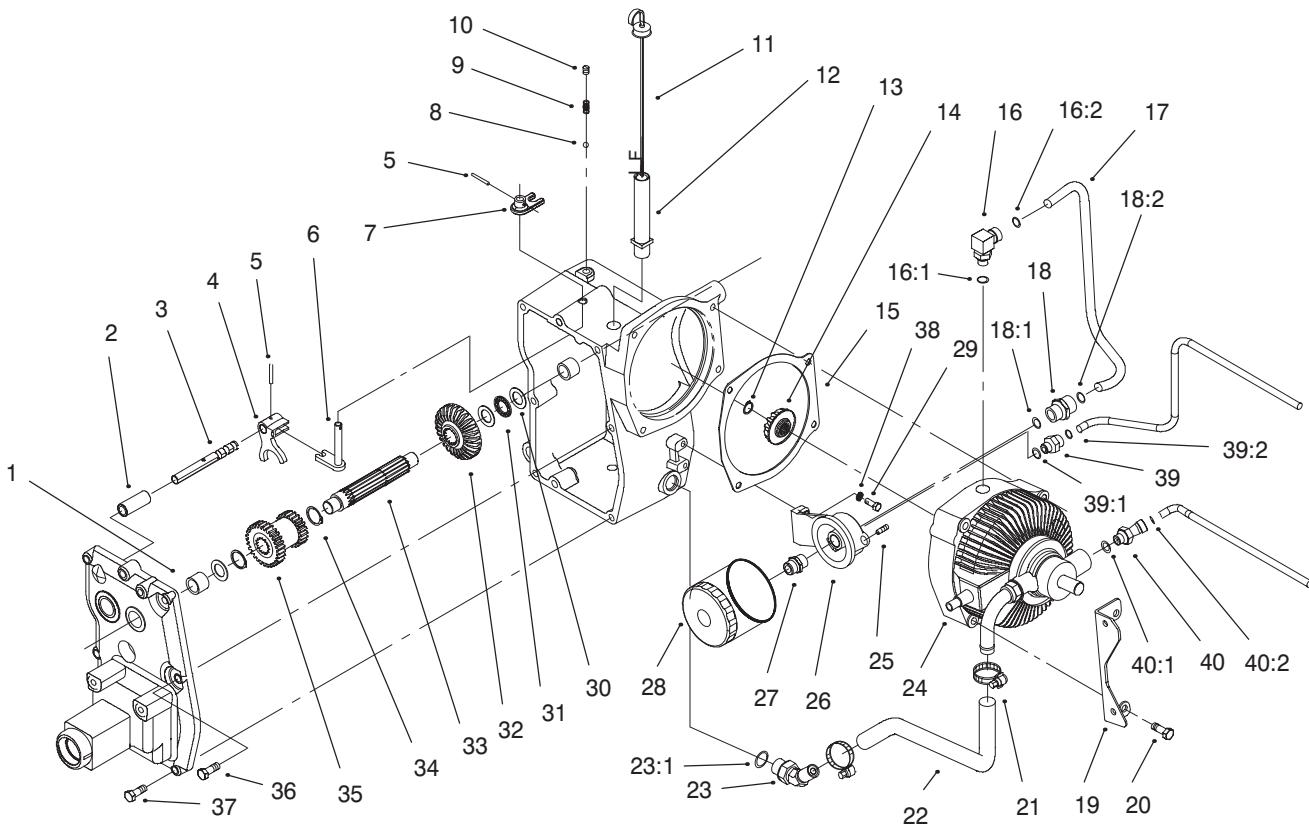

Sheet No.:16

## Hydro Transaxle Assembly

Ref. No.	Part No.	Qty.	Description
1	1529	2	Bearing-Needle
2	94-2014	1	Tube - Shifter Rail
3	94-2054	1	Rail - Shift
4	94-2015	1	Fork - Hi/Lo Shift
5	933154	2	Pin-Roll
6	94-2143	1	Wa - Shifter Arm
7	94-7510	1	Shift - Hi/Lo
8	3517	1	Ball-Detent
9	94-2024	1	Spring - Shift Detent
10	3247-2	1	Screw-Hex Socket Set
11	94-7680-03	1	Dipstick
12	94-7559	1	Tube - Dipstick
13	32120-64	1	Ring-External Snap
14	94-7565	1	Pinion - Bevel
15	702062	1	Gasket - Trans.
16	94-7693	1	Fitting - Orfs 08-06 90
16:1	237-42	1	O-Ring
16:2	237-30	1	O-Ring
17	94-7969	1	Tube - Hydraulic
18	94-7694	1	Fitting - Orfs 08-06 Str
18:1	237-42	1	O-Ring
18:2	237-30	1	O-Ring
19	94-2148-03	1	Plate-Sprt Brkt

Ref. No.	Part No.	Qty.	Description
20	323-13	4	Screw-HH
21	2412-141	2	Clamp-Drive, Worm
22	95-4133	1	Hose - Suction
23	94-7692	1	Fitting - Hose
23:1	237-80	1	O-Ring
24	94-2003	1	Transmission - Hydro
25	99-8551	1	Plug-Pipe
26	108323	1	Base-Filter
27	5991	1	Fitting
28	79-5270	1	Ass'y-Oil Filter
29	321-5	2	Screw-HH
30	1535	3	Washer-Thrust
31	8571	1	Bearing-Thrust
32	94-7566	1	Gear - Bevel
33	94-2010	1	Shaft - Input
34	32151-29	2	Ring-Snap, External
35	94-2011	1	Gear - Hi/Lo
36	323-9	3	Screw-HH
37	323-8	2	Screw-HH
38	3253-3	2	Washer-Lock/Sp
39	95-4138	1	Fitting - Hydr. Straight
39:1	237-22	1	O-Ring
39:2	237-42	1	O-Ring
40	95-4135	1	Fitting - Hydraulic 45
40:1	237-42	1	O-Ring
40:2	237-22	1	O-Ring

# Transmission Assembly

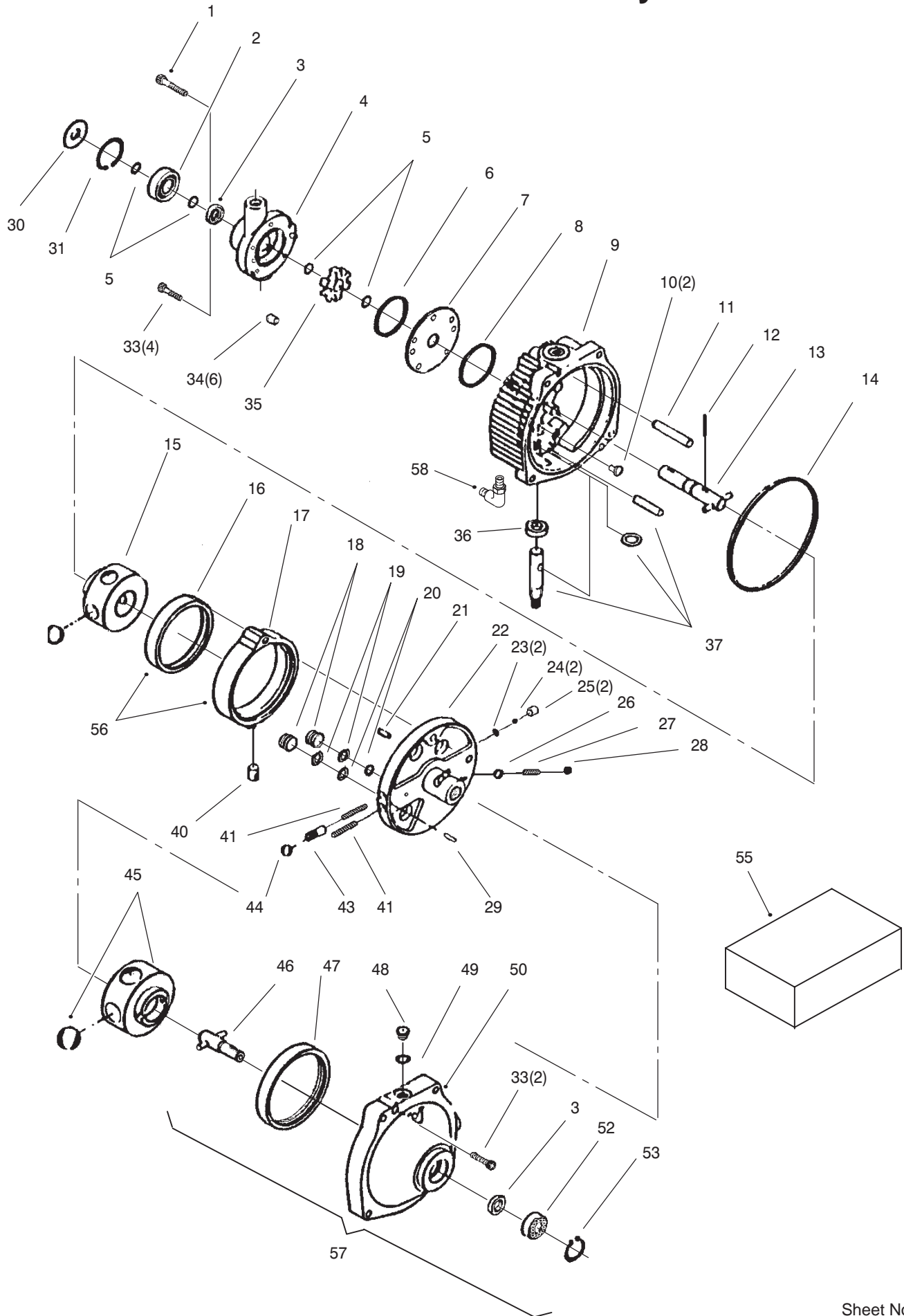





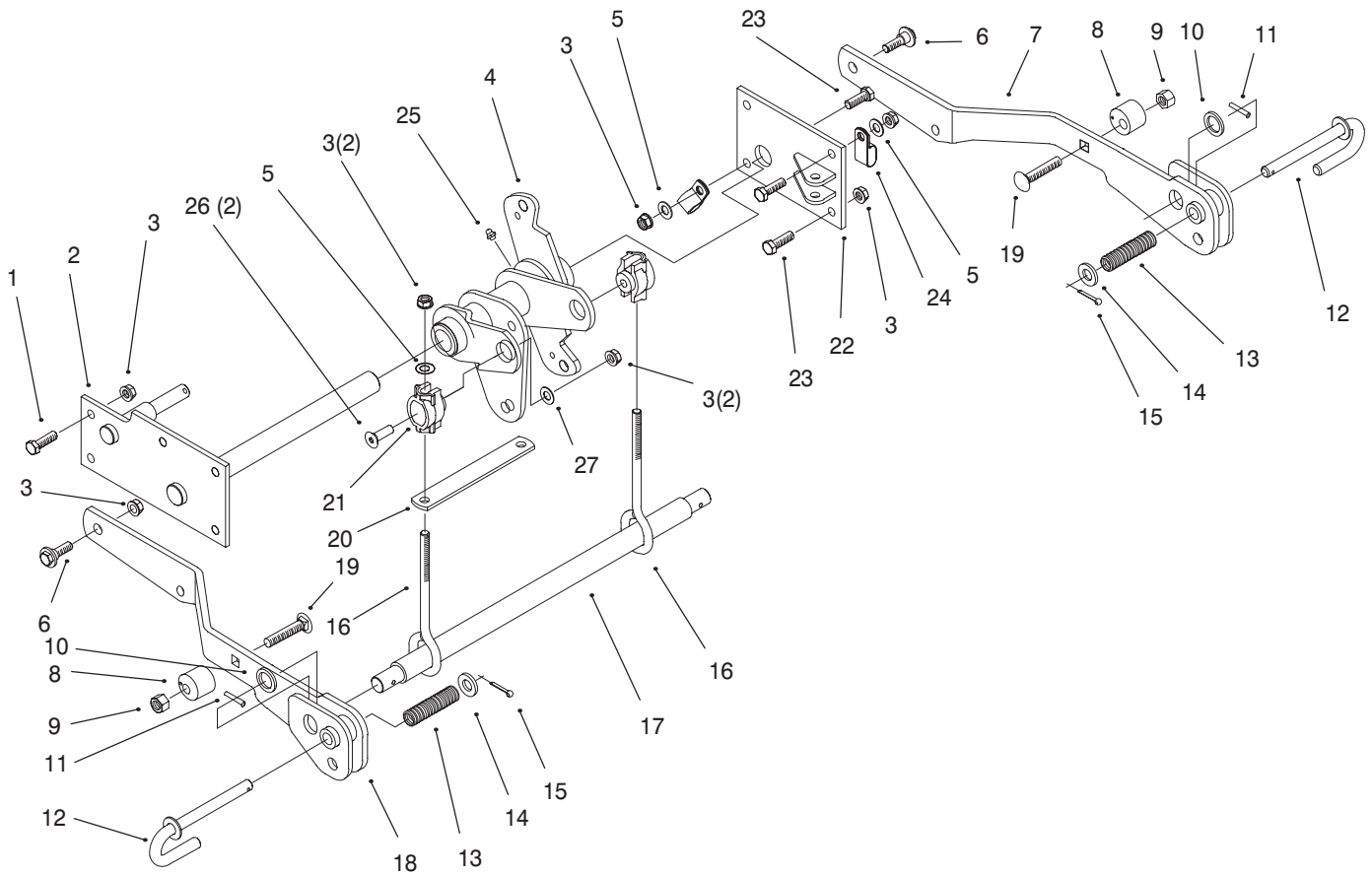

Sheet No.:18

## Lower Hydro Lift Assembly

Ref. No.	Part No.	Qty.	Description
1	323-7	5	Screw-HH
2	94-2263-03	1	Wa-Deck Lift Support
3	3296-39	13	Nut-Lock, NI
4	99-4430	1	Bellcrank And Bushing ASM
5	3256-24	2	Washer-Flat (only on: 73471, 73542)
6	614672	2	Bolt-Shoulder
7	94-2279-03	1	Wa - LH Lift Arm
8	94-2411	2	Stop - Lift Adj
9	3296-48	2	Nut-Lock NI
10	3256-28	2	Washer-Flat
11	32121-79	2	Pin-Roll
12	94-2301	2	Pin - J
13	95-4256	2	Spring - Compression
14	3256-26	2	Washer-Flat
15	3272-10	2	Pin-Cotter
16	94-2262	2	Rod - Lift
17	94-2277-03	1	Bar - Lift
18	94-2278-03	1	Wa - RH Lift Arm
19	3232-5	2	Screw-CARR
20	94-7600-03	1	Spacer-Strap
21	99-2344	2	Sleeve-Lift
22	94-7578-03	1	Plate - LH Support
23	323-18	4	Screw-HH
24	98-1617	1	Clamp-Tube

Ref. No.	Part No.	Qty.	Description
25	302-5	1	Fitting-Lube
26	99-8051	2	Screw
27	99-6496	2	Washer-Flat

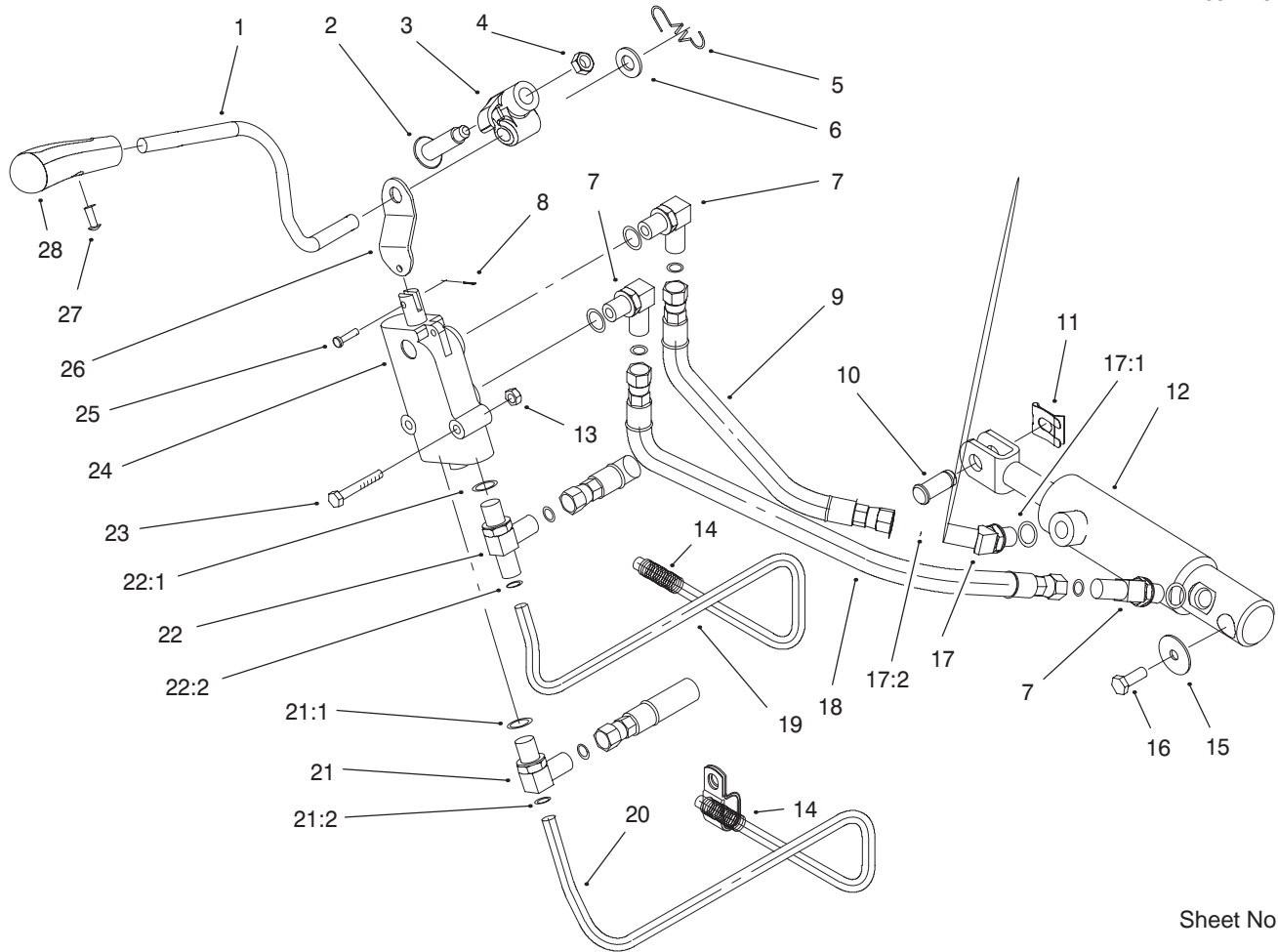

Sheet No.:19

## Upper Hydro Lift Assembly

Ref. No.	Part No.	Qty.	Description
1	94-7714	1	Handle – Lift
2	92-1099	1	Bolt-Shoulder
3	95-4168	1	Trunnion – Lift Lever
4	610358	1	Nut-Jam, Locking
5	95-4221	1	Spring – Lift Extension
6	95-4235	1	Washer
7	95-4141	3	Fitting – Hydraulic 90
8	3272-1	1	Pin-Cotter
9	94-7945	1	Assembly – Hose
10	98-1639	1	Pin-Clevis
11	95-4064	1	Clip-Pin
12	94-2300	1	ASM – Lift Cylinder
13	3296-42	2	Nut-Lock
14	95-4258	2	Cover – Brace
15	3256-57	1	Washer-Flat
16	95-4245	1	Screw – Thread Locking
17	95-4136	1	Fitting – Hydraulic 45
17:1	237-42	1	O-Ring
17:2	237-21	1	O-Ring
18	94-7944	1	Assembly – Hose
19	94-7970	1	Tube – Hydraulic
20	95-3806	1	Tube – Hydraulic
21	95-4138	1	Fitting – Hydr. Straight
21:1	237-22	1	O-Ring

Ref. No.	Part No.	Qty.	Description
21:2	237-42	1	O-Ring
22	95-4137	1	Fitting – Hydraulic Long
22:1	237-42	1	O-Ring
22:2	237-22	1	O-Ring
23	321-10	2	Screw-HH
24	94-2458	1	Valve – Hydro Lift
25	283-16	1	Pin-Clevis
26	98-1620	1	Link – Lift
27	95-4236	1	Tscrew – PPH
28	94-2100	1	Knob – Lift (only on: 73471, 73542)
28	95-4106	1	Knob – Lift (Int'l) (only on: 73570)

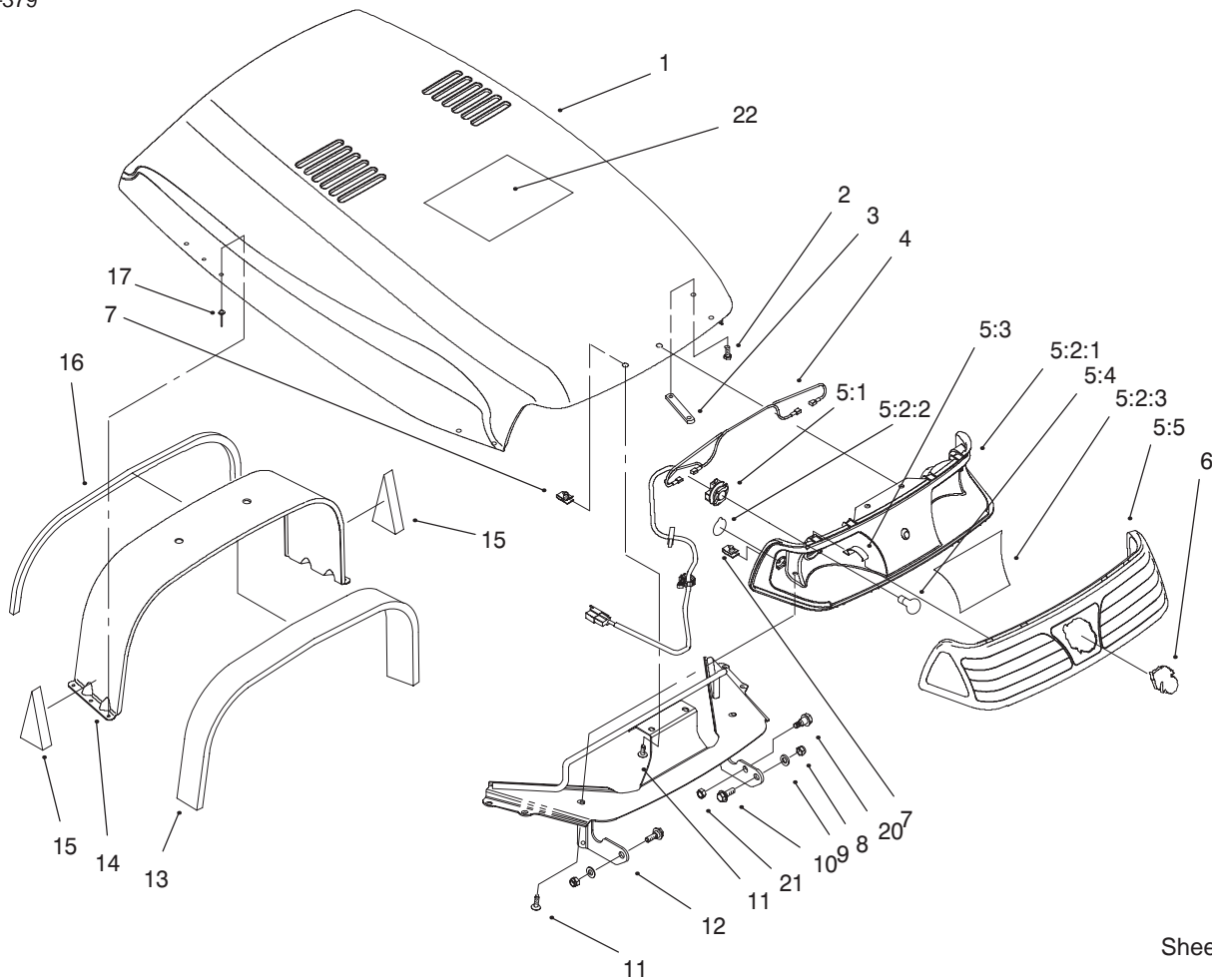

Sheet No.:20

## Hood & Headlight Assembly

Ref. No.	Part No.	Qty.	Description
1	98-7205	1	Assembly – Hood (Service)
2	63-8590	4	Screw
3	99-2323	2	Plate-Nut
4	95-0691	1	Harness – Wire,Lights
*5	95-4166	1	Assembly – Headlight
5:1	98-3591	2	ASM – Socket, Sealed
*5:2	98-7210	1	Assembly-Light Reflector
5:2:1	94-2098	1	Reflector – Headlight
5:2:2	98-1602	2	Decal – Sidelight
5:2:3	98-3597	1	Decal-Headlight Reflector
5:3	95-4129	4	Clip – Retainer
5:4	7228	2	Bulb –No. 1156
5:5	94-2099	1	Lens – Headlight
6	95-4248	1	Logo – Horsehead
7	107069	4	Clip
8	3296-29	2	Nut-Lock, NI
9	3256-23	2	Washer-Flat
10	27-0410	2	Screw-Shoulder
11	92-7020	4	Screw-HH
12	99-4962-03	1	Front Bulkhead, W.a.
13	95-4078	1	Foam Seal – Rear Bh
14	95-3902-03	1	Wa-Rear Bulkhead

Ref. No.	Part No.	Qty.	Description
15	95-4259	2	Foam – Lower Bulkhead
16	95-4233	1	Foam – Tape
17	3269-12	6	Rivet-Pop
20	92-6986	1	Bolt – Shoulder
21	3296-47	1	Nut-Lock, NI
22	100-7304	1	Decal-Services 5xi (only on: 73471, 73542)

\*Not illustrated



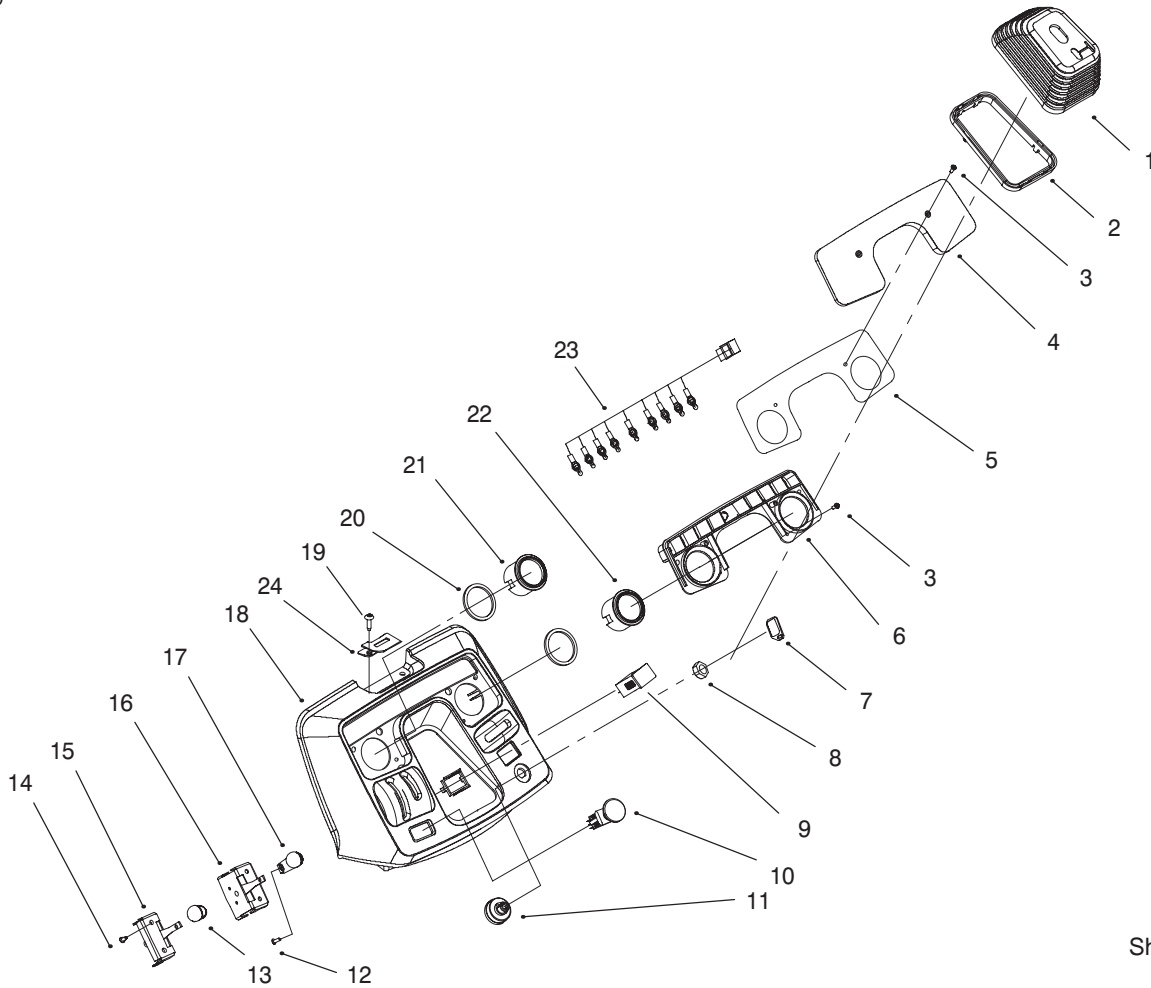

Sheet No.:22

## Dash Assembly

Ref. No.	Part No.	Qty.	Description
1	94-2102	1	Boot – Steering
2	95-3844	1	Retainer – Boot
3	95-4234	6	Screw – Pan Hd X-Recess
4	95-3842	1	Lens – Dash
5	95-4072	1	Decal – Dash Lens (only on: 73542, 73570)
5	95-4071	1	Decal – Dash Lens (only on: 73471)
6	95-3843	1	Housing – Light,Dash
7	62-7770	1	Key-Ignition
8	700919	1	Nut
9	94-4208	1	Hourmeter
10	95-7489	1	Switch – PTO
11	92-6785	1	Switch – Ignition
12	95-4236	2	Tscrew – PPH
13	94-2121	1	Knob – Throttle
14	32144-32	4	Screw
15	95-4036	1	ASM – Throttle Control
16	95-4035	1	Assembly – Choke Control
17	94-2122	1	Knob – Choke
18	94-2101	1	Dash
19	92-7020	4	Screw-HH

Ref. No.	Part No.	Qty.	Description
20	95-4238	2	Gasket – Foam
21	94-7616	1	Gauge – Oil Temperature
22	95-3830	1	Gauge-Fuel
23	99-3719	1	Harness-Light Khl 18 (only on: 73471)
23	99-3720	1	Harness-Light Khl 20,22 (only on: 73542, 73570)
24	95-4287	1	Guard – Latch (only on: 73570)

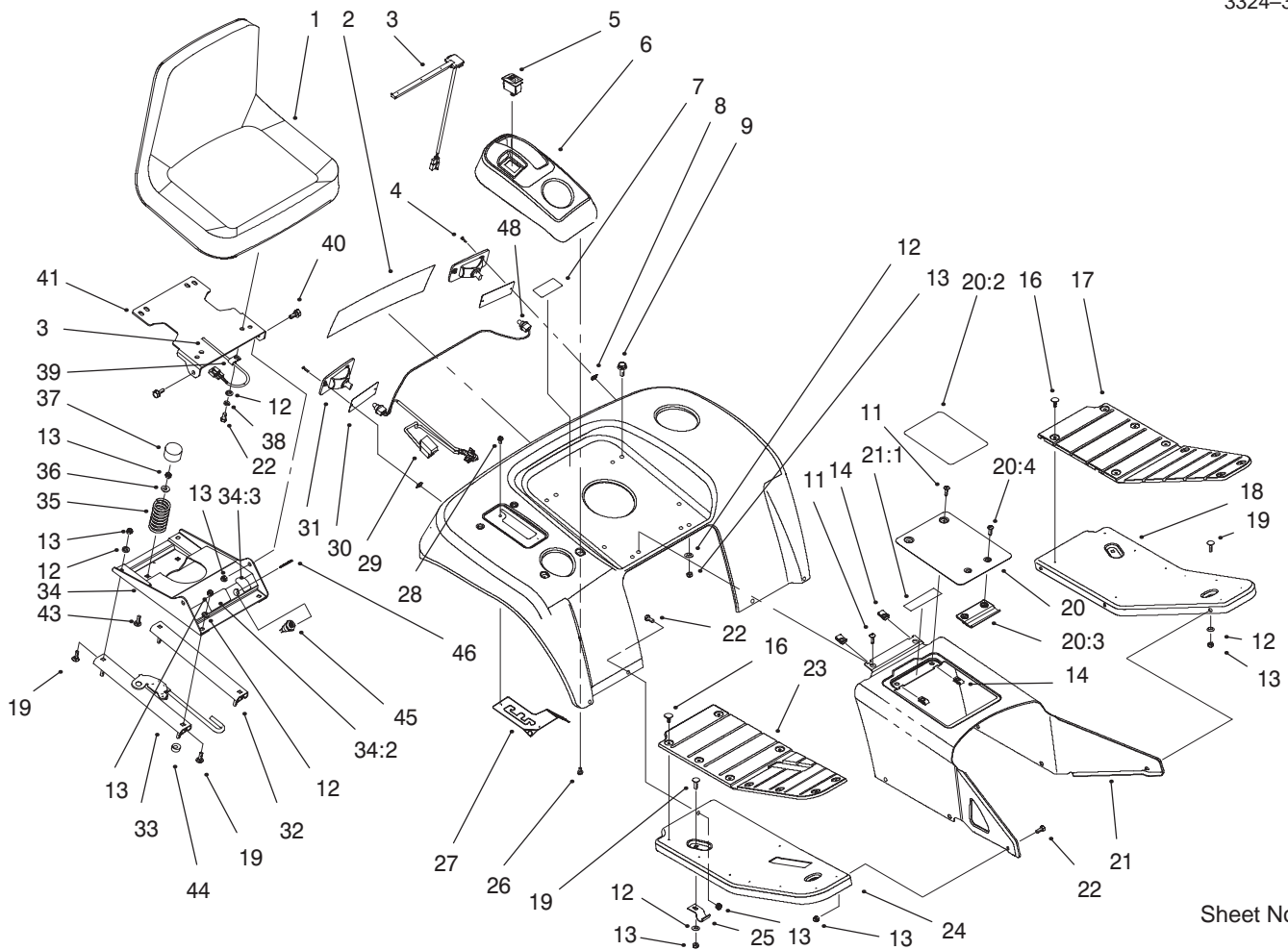

Sheet No.:23

## Fender, Footrest, & Seat Assembly

Ref. No.	Part No.	Qty.	Description
1	92-6511	1	Seat V-511 (only on: 73471)
1	94-3518	1	Seat (only on: 73542, 73570)
2	95-4262	1	Decal - Fender
3	38-1420	1	Switch-Seat
4	3250-29	4	Screw-PPH
5	94-7602	1	Switch - Cruise (only on: 73542, 73570)
6	94-2120	1	Pod - Control (only on: 73542)
6	95-4001	1	Pod - Control 18 HP (only on: 73471)
6	95-4000	1	Pod - Control Int'l (only on: 73570)
7	76-1340	1	Decal - USA (only on: 73471, 73542)
8	95-4115	4	Nut - Speed
9	3234-29	4	Screw-HHF
11	92-7020	4	Screw-HH
12	3256-23	21	Washer-Flat (only on: 73471, 73542)
12	3256-23	16	Washer-Flat (only on: 73570)
13	3296-29	29	Nut-Lock, NI
14	107069	4	Clip

Ref. No.	Part No.	Qty.	Description
16	3290-479	18	Fastener-Panel
17	94-2096	1	Pad - LH Footrest
18	94-2090-01	1	Footrest - LH
19	3230-16	8	Screw-HH
20	99-6089	1	ASM Cover/Decal (only on: 73471, 73542)
20	98-1623	1	ASM - Tunnel Cover Europe (only on: 73570)
20:2	99-6090	1	Decal-Danger (only on: 73471, 73542)
20:2	98-1608	1	Decal - Danger Europe (only on: 73570)
20:3	95-4107	1	Retainer - Cover
20:4	94-4496	2	Screw-PPH (only on: 73570)
21	98-5025	1	ASM - Tunnel w/Decal (only on: 73471, 73542)
21	98-5058	1	ASM - Tunnel w/Decal Europe (only on: 73570)
21:1	98-5015	1	Decal - Warning (only on: 73570)

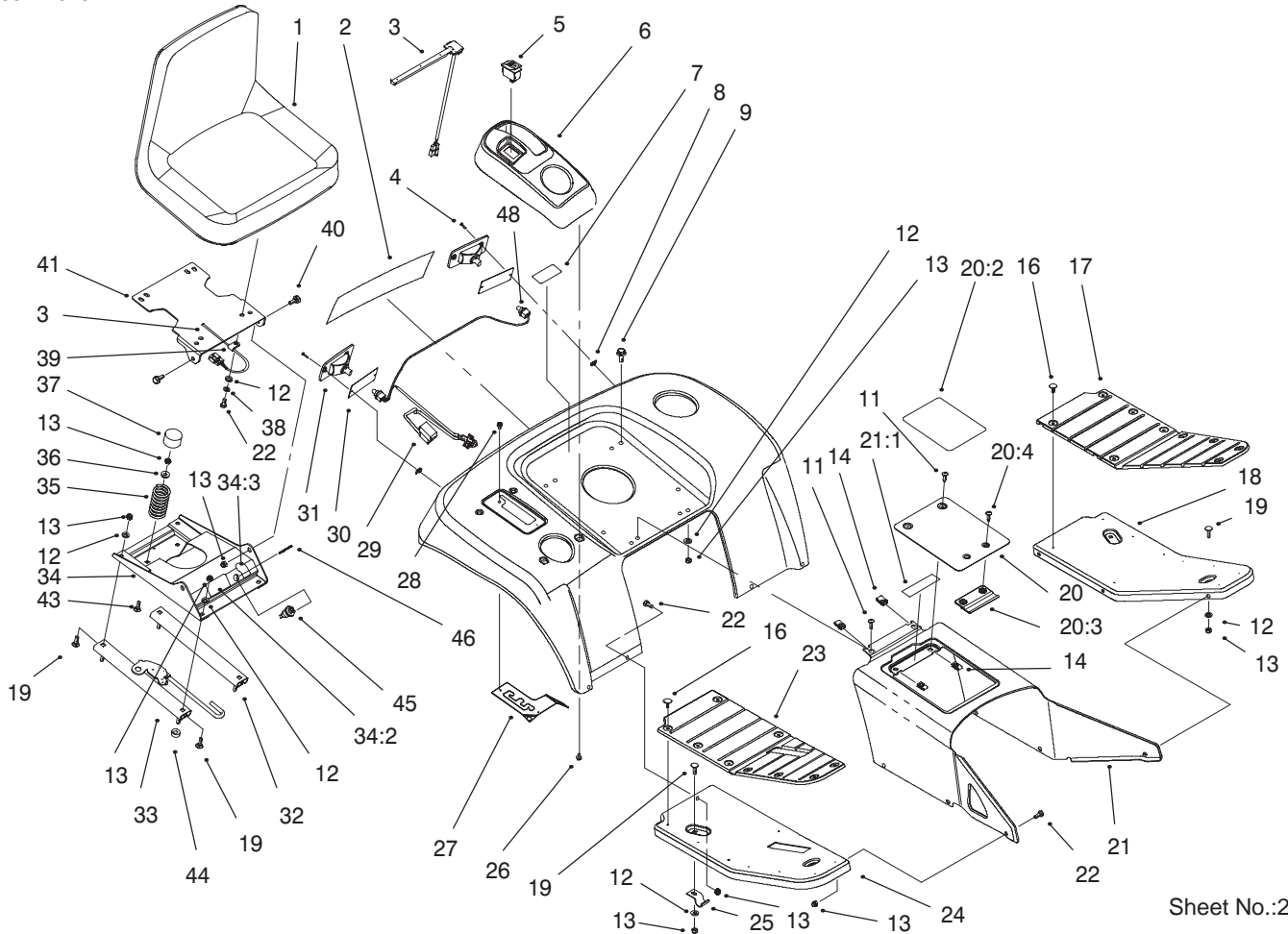

Sheet No.:23

## Fender, Footrest, & Seat Assembly (cont.)

Ref. No.	Part No.	Qty.	Description
21:1	80-8760	1	Decal – Danger (only on: 73471, 73542)
22	322-3	18	Screw-HH
23	94-2095	1	Pad – RH Footrest
24	94-2089-01	1	Footrest – RH
25	95-3858	2	Bracket-Footrest
26	32144-20	4	Screw-Thread Forming
27	98-8711-03	1	Gate – Hi/Lo Shift
28	32144-4	2	Screw-HH
29	99-3726	1	Harness-Rear (only on: 73542, 73570)
30	95-4123	2	Gasket – Tail Light (only on: 73471)
31	95-4089	2	Reflector (only on: 73471)
31	94-2124	2	Lamp – Taillight (only on: 73542, 73570)
32	94-2112	1	Slide – Seat Slave
33	94-2177	1	Slide – Seat Latch
34	99-6099	1	Seat Base ASM-Intl (only on: 73570)
34	99-6098	1	Seat Base ASM (only on: 73471, 73542)
34:2	99-2985	1	Decal-Danger (only on: 73471, 73542)

Ref. No.	Part No.	Qty.	Description
34:3	99-5339	1	Decal-Nmir Switch (only on: 73471, 73542)
35	94-2106-03	2	Spring – Compression
36	105503	2	Bushing
37	95-4242	2	Cap – Seat Spring
38	3253-4	4	Washer
39	98-2390	1	Clamp – R
40	37-8771	2	Bolt-Shoulder
41	94-2111-03	1	Mount – Seat
43	3230-22	2	Screw-CARR
44	4-2390	4	Washer
45	46-5780	1	Switch-Starter
46	62-7770	1	Key-Ignition
48	109045	2	Light Bulb

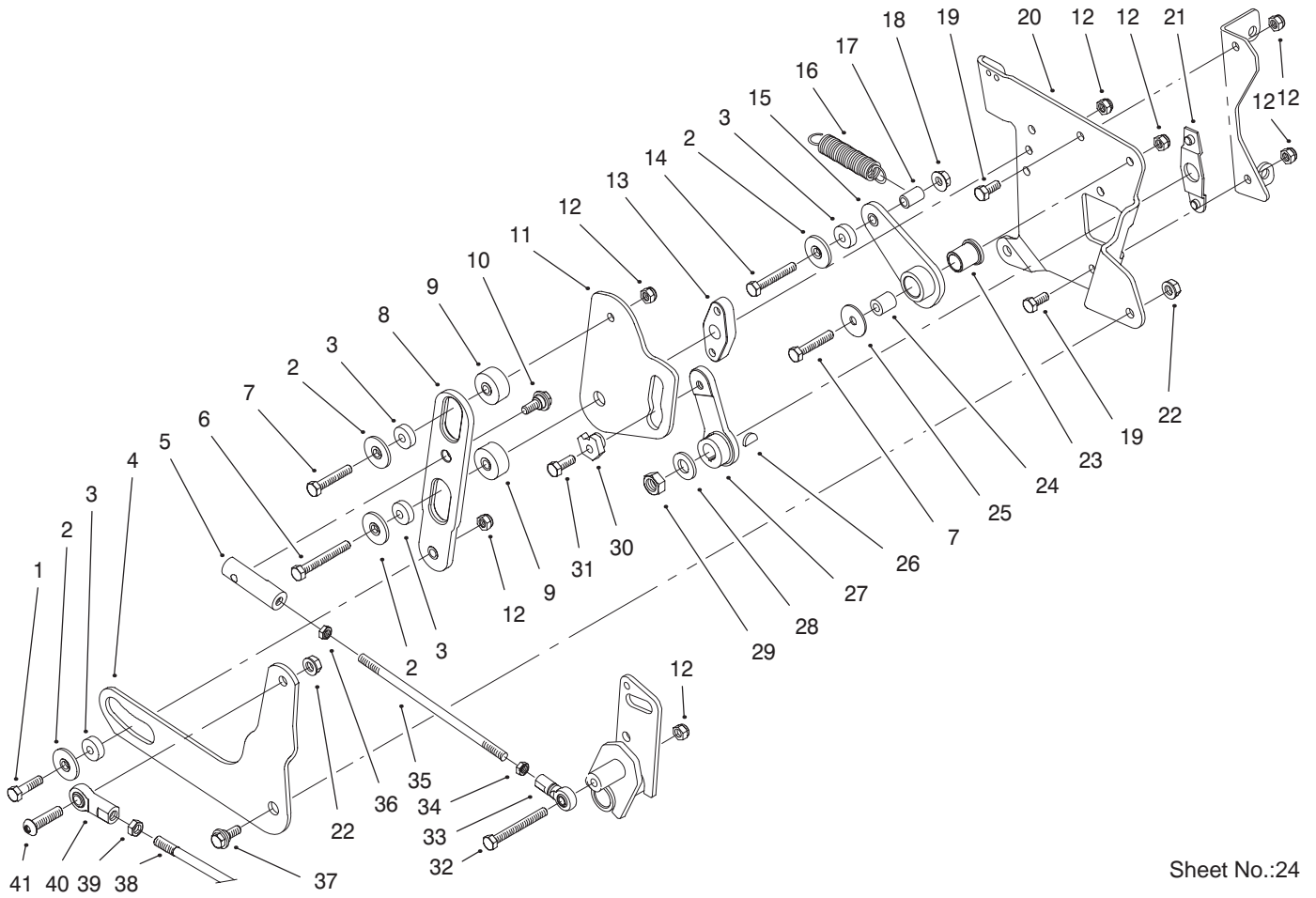

Sheet No.:24

## Rear Smart Turn Assembly

Ref. No.	Part No.	Qty.	Description
1	322-6	1	Screw-HH
2	94-2313	4	Retainer - Bearing
3	95-4185	4	Bearing - Ball
4	95-3801-03	1	Wa - Lift Slider
5	94-7637	1	End - 5/16 RH Rod
6	322-12	1	Screw-HH
7	322-9	2	Screw-HH
8	94-2144	1	Slider - Speed Control
9	94-2169	2	Standoff - Cam Plate
10	94-7817	1	Bolt - Shoulder
11	94-2145	1	Plate - Cam
12	3296-29	8	Nut-Lock, NI
13	94-2168	1	Standoff - Slider
14	322-10	1	Screw-HH
15	94-7586	1	Arm - Rtn To Neutral
16	63-1590	1	Spring-Idler
17	94-2309	1	Standoff - Spring
18	3256-23	1	Washer-Flat
19	322-3	2	Screw-HH
20	99-8053-03	1	Plate-Control
21	94-7814	1	Locator-Control Plate
22	108881	2	Nut-Differential
23	94-7913	1	Bushing - Flanged
24	94-7564	1	Spacer
25	3256-57	1	Washer-Flat
26	3257-24	1	Key-Woodruff

Ref. No.	Part No.	Qty.	Description
27	94-7816	1	Arm - Speed Control
28	3256-26	1	Washer-Flat
29	3296-45	1	Nut-Lock, NI
30	94-2468	1	Cam
31	95-4245	1	Screw - Thread Locking
32	322-13	1	Screw-HH
33	94-7571	1	End - RH Rod
34	3220-20	1	Nut-Jam LH
35	94-2497	1	Rod - Slider To Pivot
36	3220-2	1	Nut-Jam
37	94-7582	1	Bolt - Shoulder
38	94-7500	1	Rod-Lift Lever To Strg
39	3220-3	1	Nut-Jam
40	92-7008	1	Rod End - Female
41	95-3857	1	Screw-Head, Button

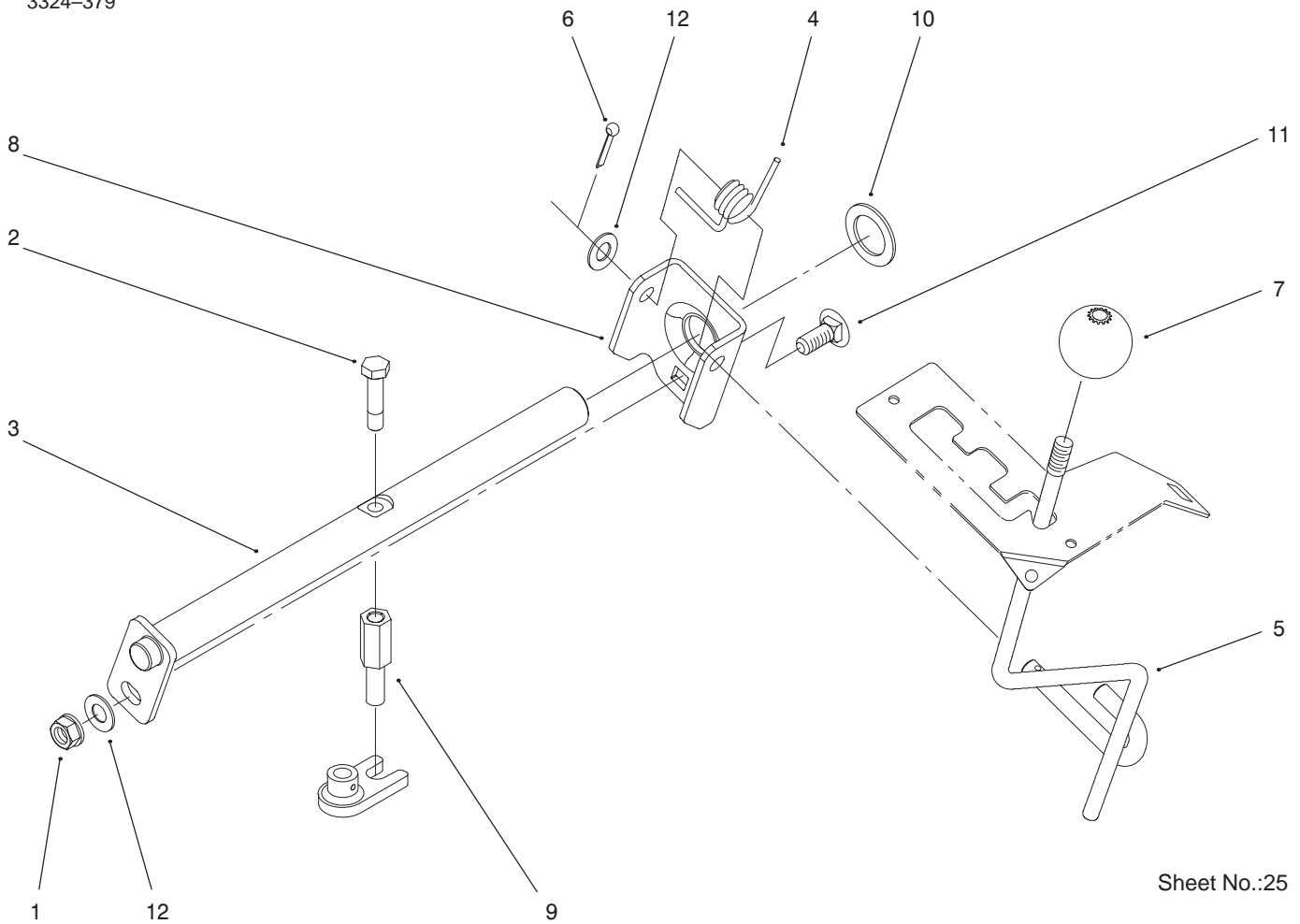

Sheet No.:25

## Hi-Lo Shift Assembly

Ref. No.	Part No.	Qty.	Description
1	3296-39	1	Nut-Lock, NI
2	99-4953	1	Screw-Thread Locking
3	99-4445	1	Shift Rod ASM-Welded
4	99-4446	1	Spring-Torsion
5	99-4448	1	Lever-Shift W.a.
6	3272-10	1	Pin-Cotter
7	95-4022	1	Knob - Hi/Lo Shift
8	99-4951	1	Bracket-Pivot
9	99-4952	1	Rod-Shift Pivot
10	99-4958	1	Spacer-Shift
11	3231-22	1	Screw-CARR
12	3256-24	2	Washer-Flat

Ref. No.	Part No.	Qty.	Description

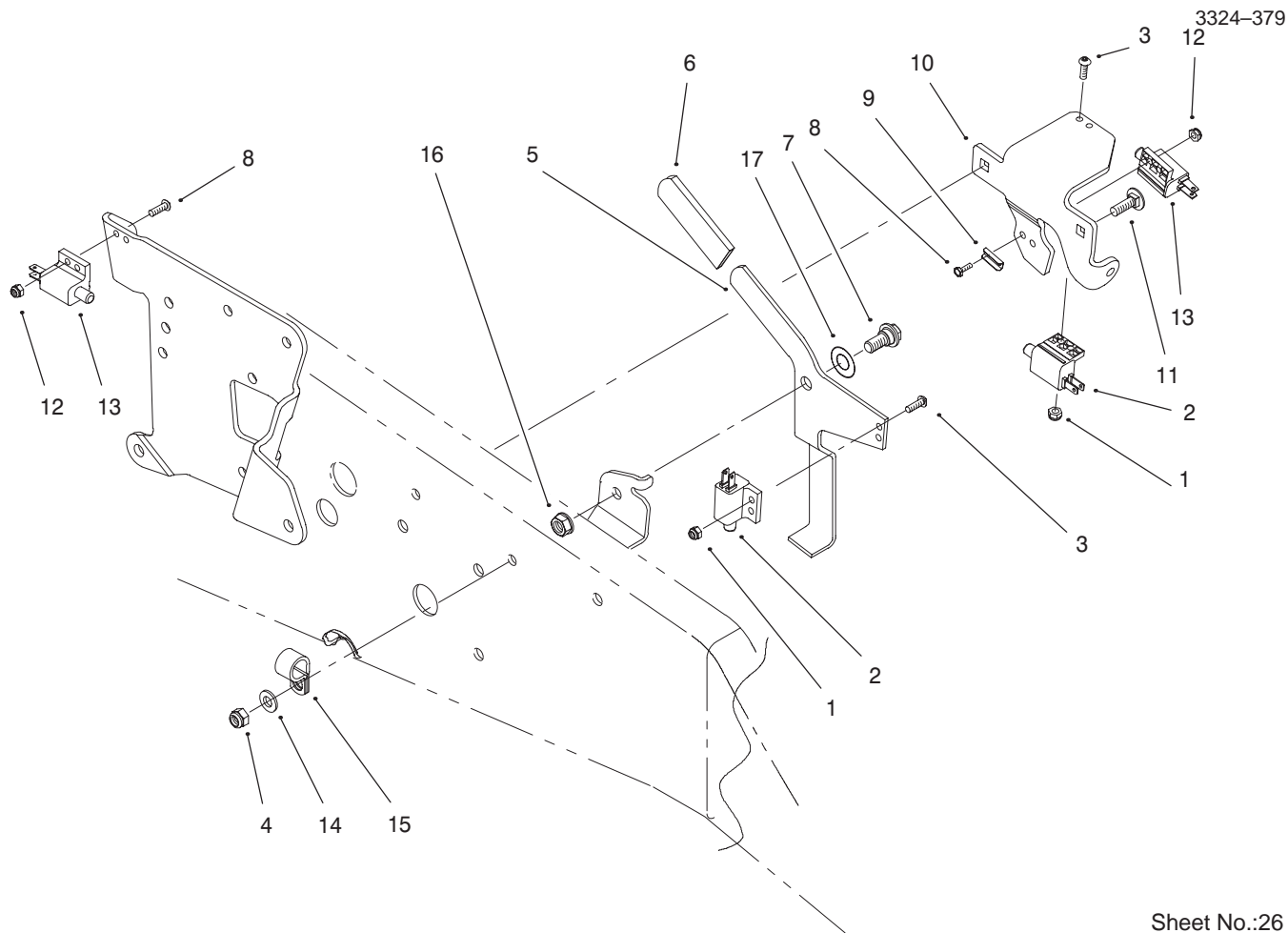

Sheet No.:26

## Upper Parking Brake Assembly

Ref. No.	Part No.	Qty.	Description
1	3296-2	4	Nut-Lock (only on: 73542, 73570)
1	3296-2	2	Nut-Lock (only on: 73471)
2	65-7410	1	Switch - Single Pole (only on: 73471)
2	65-7410	2	Switch - Single Pole (only on: 73542, 73570)
3	3274-14	4	Screw-HSH (only on: 73542, 73570)
3	3274-14	2	Screw-HSH (only on: 73471)
4	3296-29	2	Nut-Lock, NI
5	94-2157-03	1	Latch-Prking Brake
6	102597	1	Grip
7	94-7582	1	Bolt - Shoulder
8	99-8128	4	Screw
9	94-7905	1	Retainer-Screw
10	94-7562-03	1	Bracket - Switch
11	3230-16	2	Screw-HH
12	3296-1	4	Nut-Lock NI
13	95-1653	2	Switch - Single Pole
14	3256-23	1	Washer-Flat
15	98-2358	1	Clamp - R
16	108881	1	Nut-Differential

Ref. No.	Part No.	Qty.	Description
17	98-3087	1	Washer - Power Steering

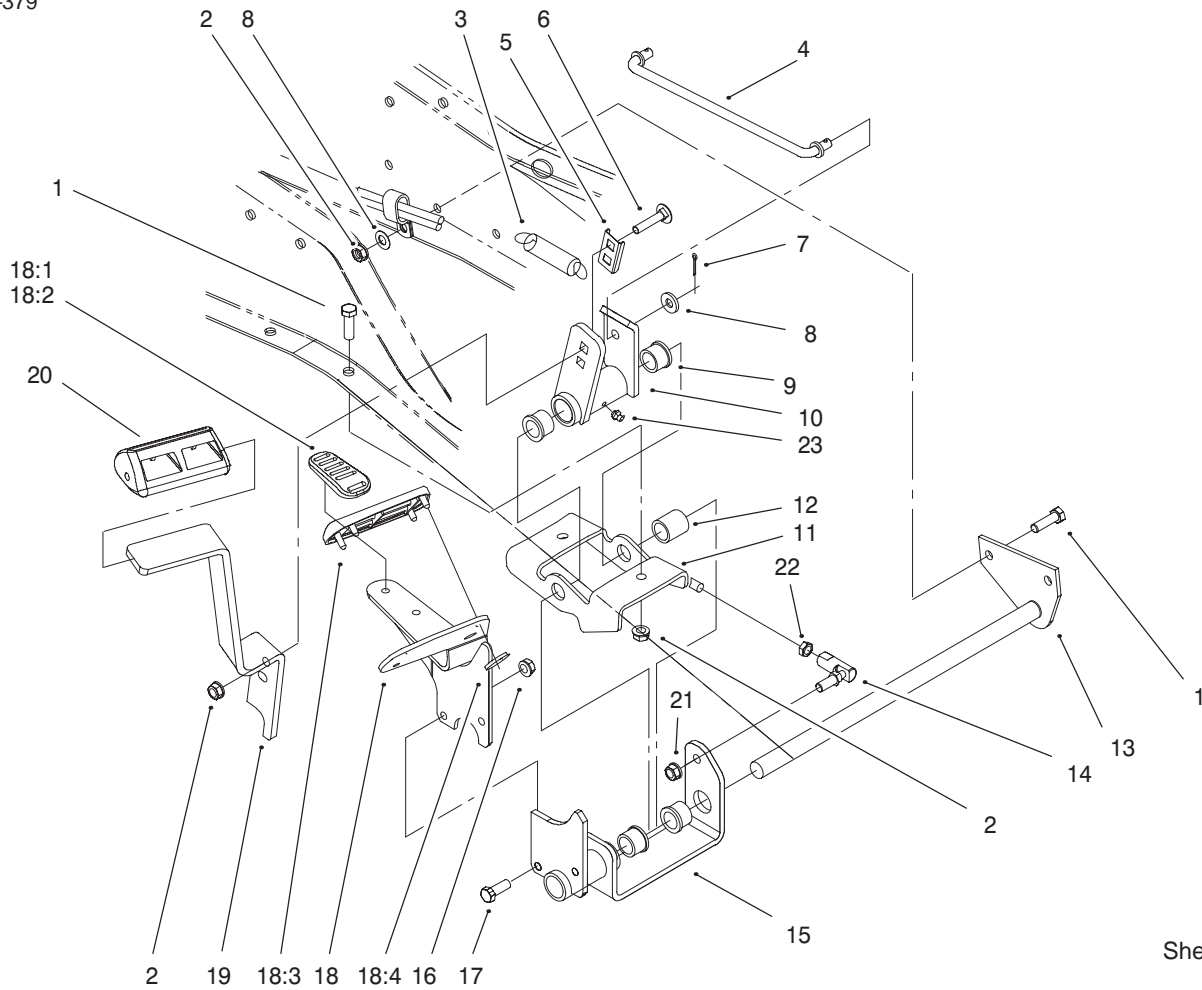

Sheet No.:27

## Hydro Controls Assembly

Ref. No.	Part No.	Qty.	Description
1	323-7	4	Screw-HH
2	3296-39	6	Nut-Lock, NI
3	63-1590	1	Spring-Idler
4	94-2499	1	Rod-Pivot Plate To Pedal
5	94-7818	1	Retainer - Screw
6	3231-25	2	Screw-CARR
7	3272-10	2	Pin-Cotter
8	3256-24	3	Washer-Flat
9	98-1636	4	Bushing - Flange
10	94-2351-03	1	Wa - Brake Bracket
11	94-2343-03	1	Bracket - Support
12	94-7501	1	Spacer - Pedal
13	94-2345-03	1	Wa-Pivot Shaft
14	94-7572	1	End - RH Tie Rod
15	94-2342-03	1	Wa-Frwd/Rev Brkt
16	3296-29	2	Nut-Lock, NI
17	322-5	2	Screw-HH
18	99-8050	1	Hydro Pedal ASM
18:1	99-2300-03	1	Hydro Pedal, W.a.
18:2	98-9039	1	Heel Pad-Hydro Pedal
18:3	98-9040	1	Toe Pad-Hydro Pedal
18:4	32112-6	6	Pushnut
19	94-2352-03	1	Pedal - Brake
20	94-2123	1	Pad - Brake Pedal
21	3296-6	1	Nut-Lock, NI

Ref. No.	Part No.	Qty.	Description
22	3220-3	1	Nut-Jam
23	302-5	1	Fitting-Lube

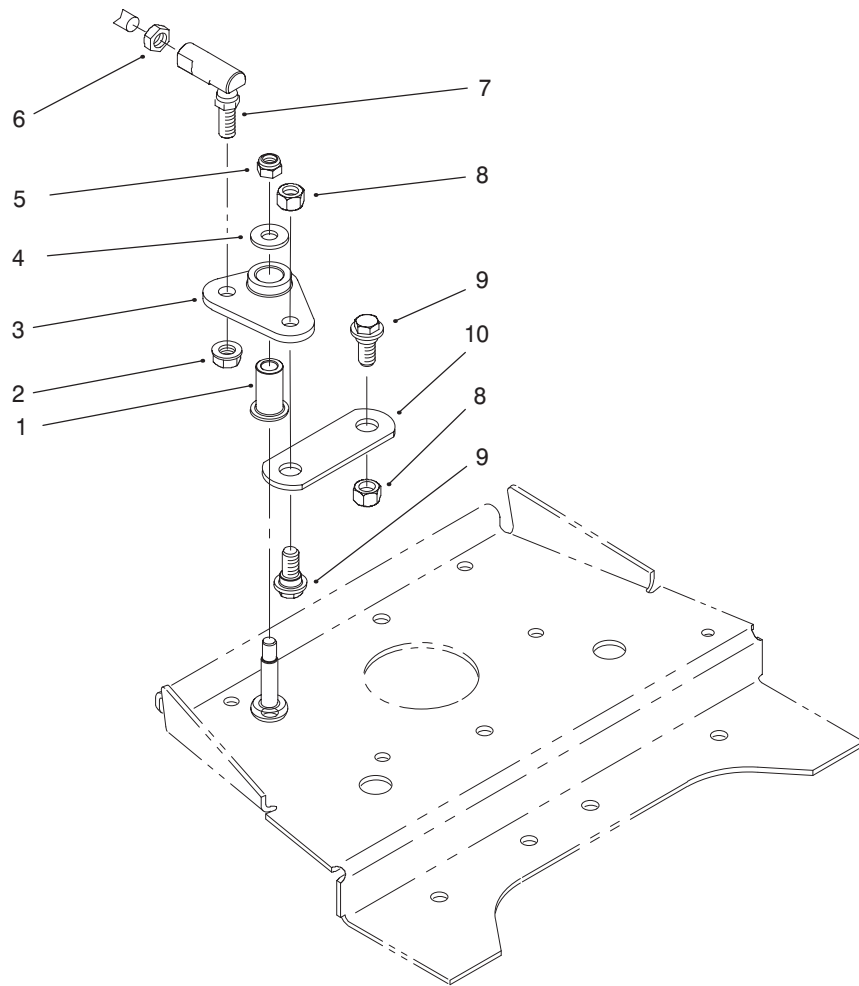

Sheet No.:28

### Front Smart Turn Assembly

Ref. No.	Part No.	Qty.	Description
1	94-7919	1	Bushing
2	3296-6	1	Nut-Lock, NI
3	94-7579	1	Lever - Slow Down
4	98-3499	1	Washer - Flat
5	3296-29	1	Nut-Lock, NI
6	3220-16	1	Nut-Jam, LH
7	94-7573	1	End - LH Tie Rod
8	108881	2	Nut-Differential
9	94-7582	2	Bolt - Shoulder
10	94-2409	1	Link - Slow Down

Ref. No.	Part No.	Qty.	Description



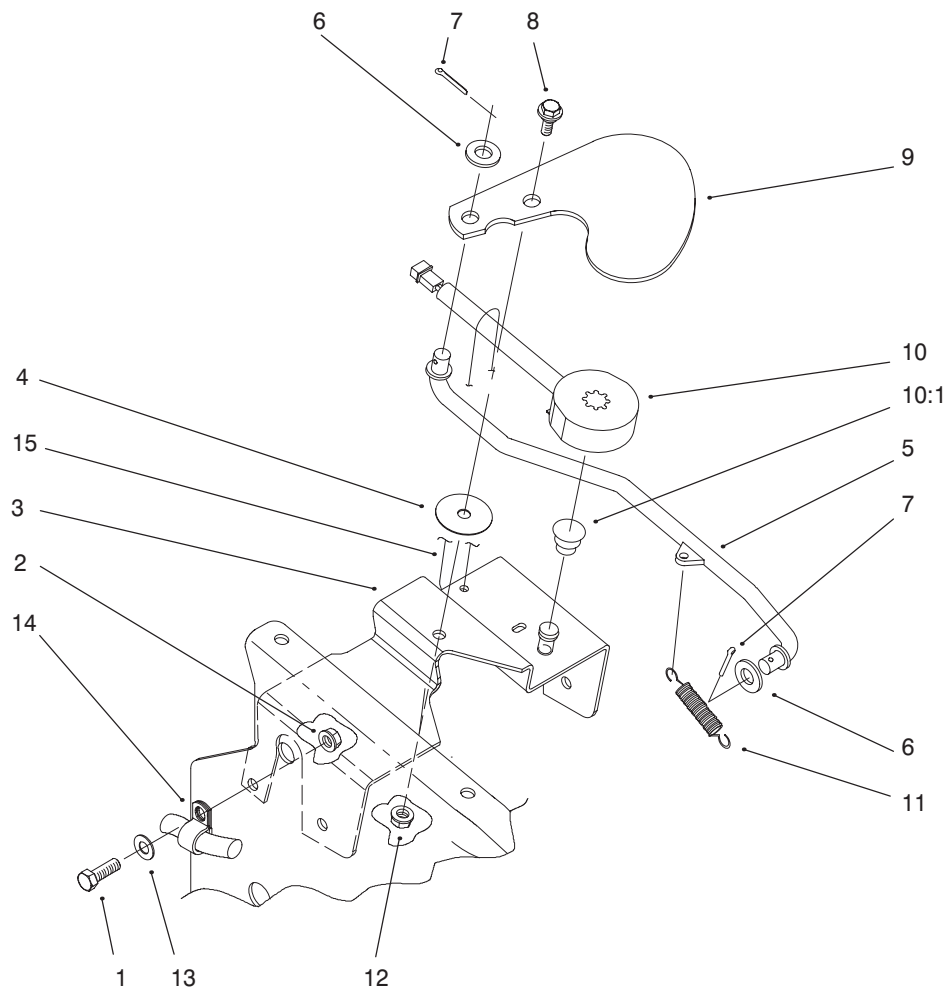

Sheet No.:30

## Cruise Control Assembly

Ref. No.	Part No.	Qty.	Description	Ref. No.	Part No.	Qty.	Description
1	323-7	4	Screw-HH (only on: 73542, 73570)	10:1	93-6601	1	Spring - Compression (only on: 73542, 73570)
1	323-7	2	Screw-HH (only on: 73471)	11	66-4160	1	Spring-Upper Solenoid (only on: 73542, 73570)
2	3296-39	2	Nut-Lock, NI (only on: 73471)	12	108881	1	Nut-Differential
2	3296-39	4	Nut-Lock, NI (only on: 73542, 73570)	13	3256-24	2	Washer-Flat
3	99-6097-03	1	Brkt-Cruise (only on: 73542, 73570)	14	98-2358	2	Clamp - R
4	94-7575	1	Spacer - Cruise (only on: 73542, 73570)	15	614249	1	Tie Strap (only on: 73542, 73570)
5	94-7980	1	Wa - Cruise Control Rod (only on: 73542, 73570)				
6	3256-26	2	Washer-Flat (only on: 73542, 73570)				
7	3272-10	2	Pin-Cotter (only on: 73542, 73570)				
8	94-7582	1	Bolt - Shoulder (only on: 73542, 73570)				
9	99-5309	1	Plate - Magnet (only on: 73542, 73570)				
10	99-8090	1	Magnet ASM (only on: 73542, 73570)				



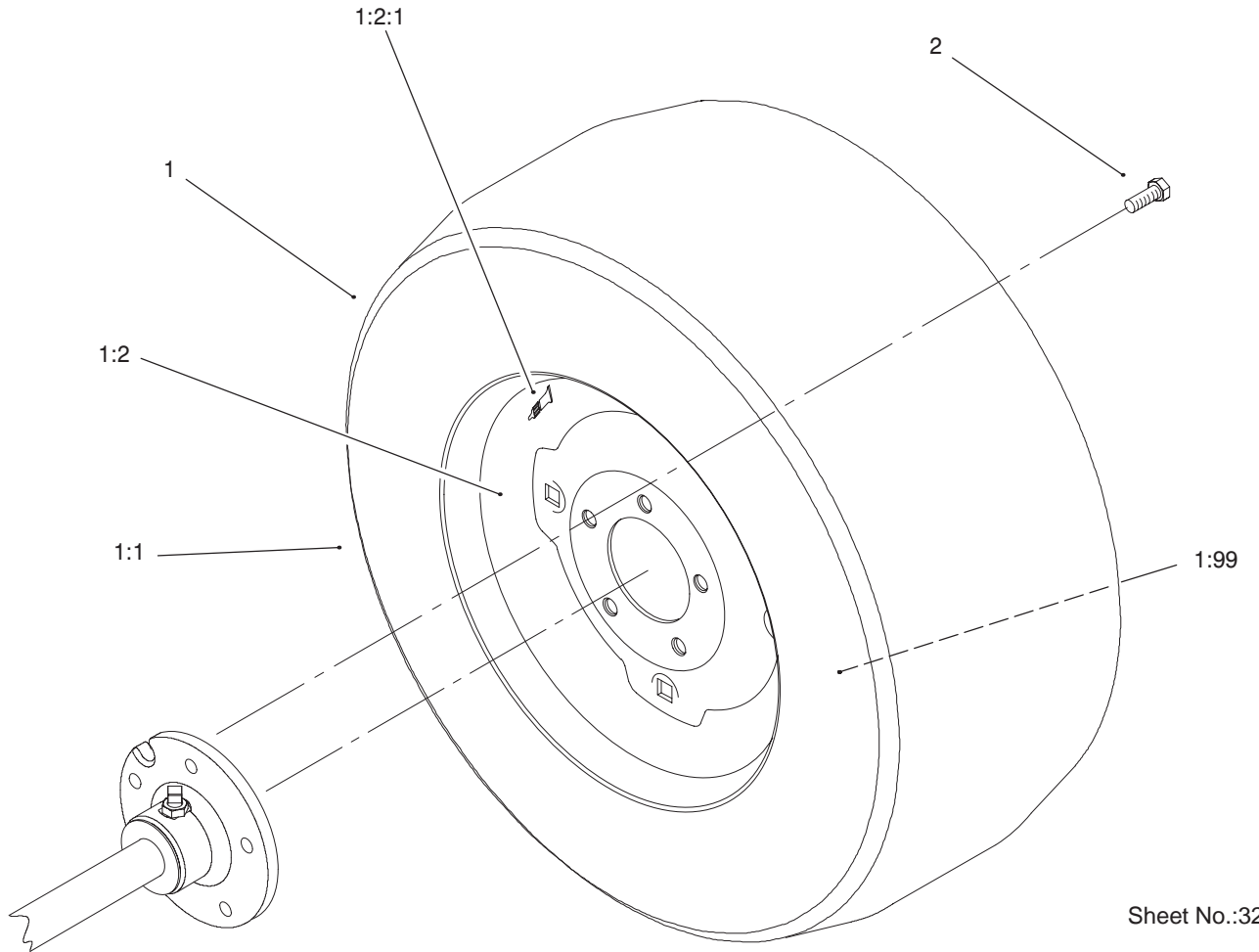

Sheet No.:32

### Wheel Assembly

Ref. No.	Part No.	Qty.	Description
1	99-3694	2	Wheel & Tire ASM, Toro
1:1	99-2334	1	Tire
1:2	110680	1	Rim-ASM, Toro
1:2:1	5108	1	Valve-Tubeless Tire
1:99	7007	1	Tube-Inner
2	83-2720	10	Lug-Bolt

Ref. No.	Part No.	Qty.	Description

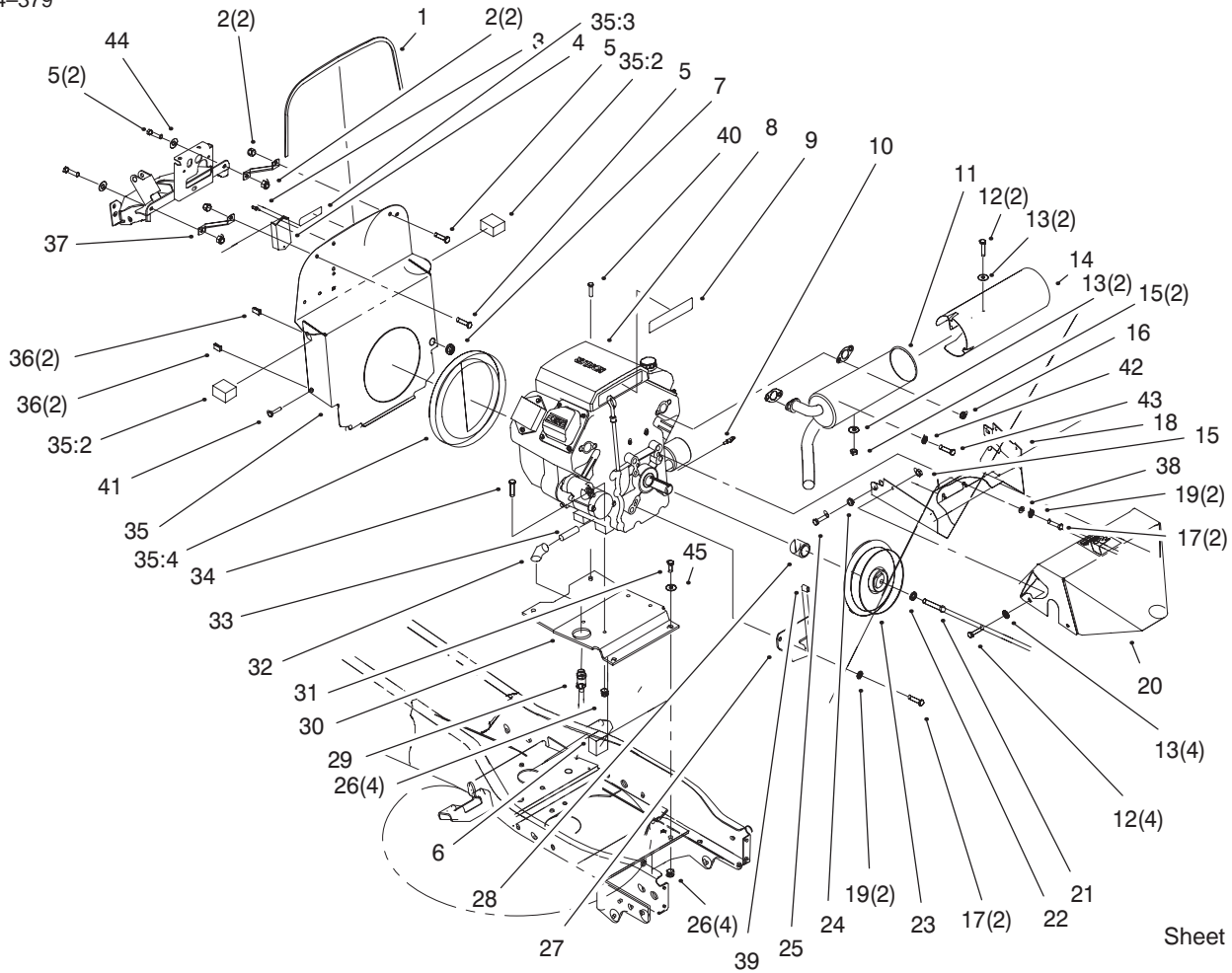

Sheet No.:33

## Air Cooled Engine Assembly

Ref. No.	Part No.	Qty.	Description
1	95-4125	1	Trim – Lock, Bulkhead
2	3296-29	4	Nut–Lock, NI
3	12-5450	1	Screw
4	99-1933	1	Module–Low Voltage
5	322-3	4	Screw–HH
6	98-3086	2	Foam Seal – Kohler, Side
7	240-9	1	Grommet
8	94-2160	1	Engine – 20hp (only on: 73542, 73570)
8	94-2159	1	Engine – 18hp (only on: 73471)
9	98-3580	1	Decal – 20 HP Engine (only on: 73542, 73570)
9	98-3579	1	Decal – 18 HP Engine (only on: 73471)
10	94-7619	1	Sender – Oil Temperature
11	94-7558	1	Muffler – Kohler
12	321-3	6	Screw–HH
13	3256-22	8	Washer–Flat
14	94-7560	1	Reflector – Heat
15	32152-4	6	Nut–Conelock (only on: 73471, 73570)
16	92-6780	4	Nut–Hex Flange

Ref. No.	Part No.	Qty.	Description
17	323-6	4	Screw–HH
18	94-7522-03	1	Shrd–Muffler
19	3253-5	4	Washer–Lock/Sp
20	94-7524-03	1	Shroud–Muffler
21	94-7973	1	Screw–HH
22	3256-25	1	Washer–Flat
23	94-2190	1	Clutch – PTO
24	3253-3	2	Washer–Lock/Sp
25	33113-008	2	Screw–HH
26	3296-39	8	Nut–Lock, NI
27	94-2356-03	1	Clutch – Stop
28	94-2068	1	Spacer – Clutch
29	92-6877	1	Valve – Oil Drain
30	94-2199-03	1	Plate – Engine
31	323-7	3	Screw–HH
32	2811-16	1	Elbow–90 Degree
33	98-7200	1	Nipple
34	323-9	4	Screw–HH
35	98-5060	1	ASM–Bulkhead w/Decal (only on: 73471, 73542)
35	98-5062	1	ASM – Bulkhead w/Decal (only on: 73570)
35:2	98-3086	2	Foam Seal – Kohler, Side



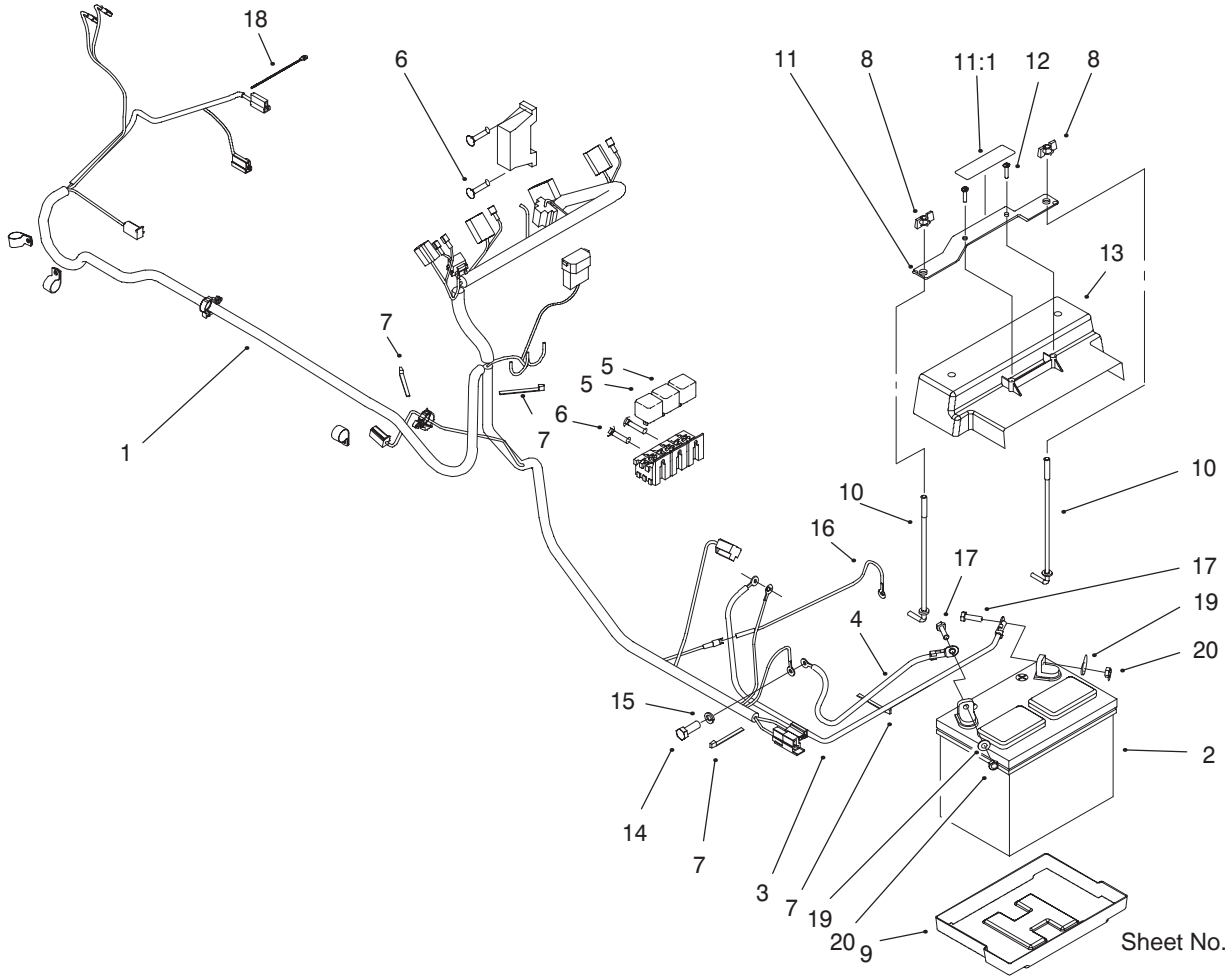

Sheet No.:43

## Electrical Assembly (Model No. 73471 Only)

Ref. No.	Part No.	Qty.	Description
1	99-3722	1	Wire Harness 18 HP (only on: 73471)
2	94-1867	1	Battery (only on: 73471)
3	95-7854	1	Cable - Battery,Red 27" (only on: 73471)
4	95-7873	1	Cable - Battery (only on: 73471)
5	98-7249	3	Relay-Speedometer (only on: 73471)
6	12-5450	4	Screw (only on: 73471)
7	614249	3	Tie Strap (only on: 73471)
8	32103-22	2	Nut-Wing (only on: 73471)
9	106948	1	Tray-Battery (only on: 73471)
10	95-4042	2	Hook-Battery Retain (only on: 73471)
11	98-5056	1	Assembly - Strap w/Decal (only on: 73471)
11:1	93-1265	1	Decal - Hot Surface (only on: 73471)

Ref. No.	Part No.	Qty.	Description
12	94-4496	2	Screw-PPH (only on: 73471)
13	95-4044	1	Shield - Battery (only on: 73471)
14	33104-020	1	Screw-HHF (only on: 73471)
15	3253-4	1	Washer (only on: 73471)
16	98-1492	1	Wire Harness - Kohler (only on: 73471)
17	321-5	2	Screw-HH (only on: 73471)
18	98-5072	1	Tie-Cable (only on: 73471)
19	3256-22	2	Washer-Flat (only on: 73471)
20	3296-42	2	Nut-Lock (only on: 73471)
*	Nn10277	1	Fuse-30 Amp (only on: 73471)
*	218-578	2	Fuse-10 Amp Blade Type (only on: 73471)
*	109102	1	Fuse-25 Amp (only on: 73471)

\*Not illustrated

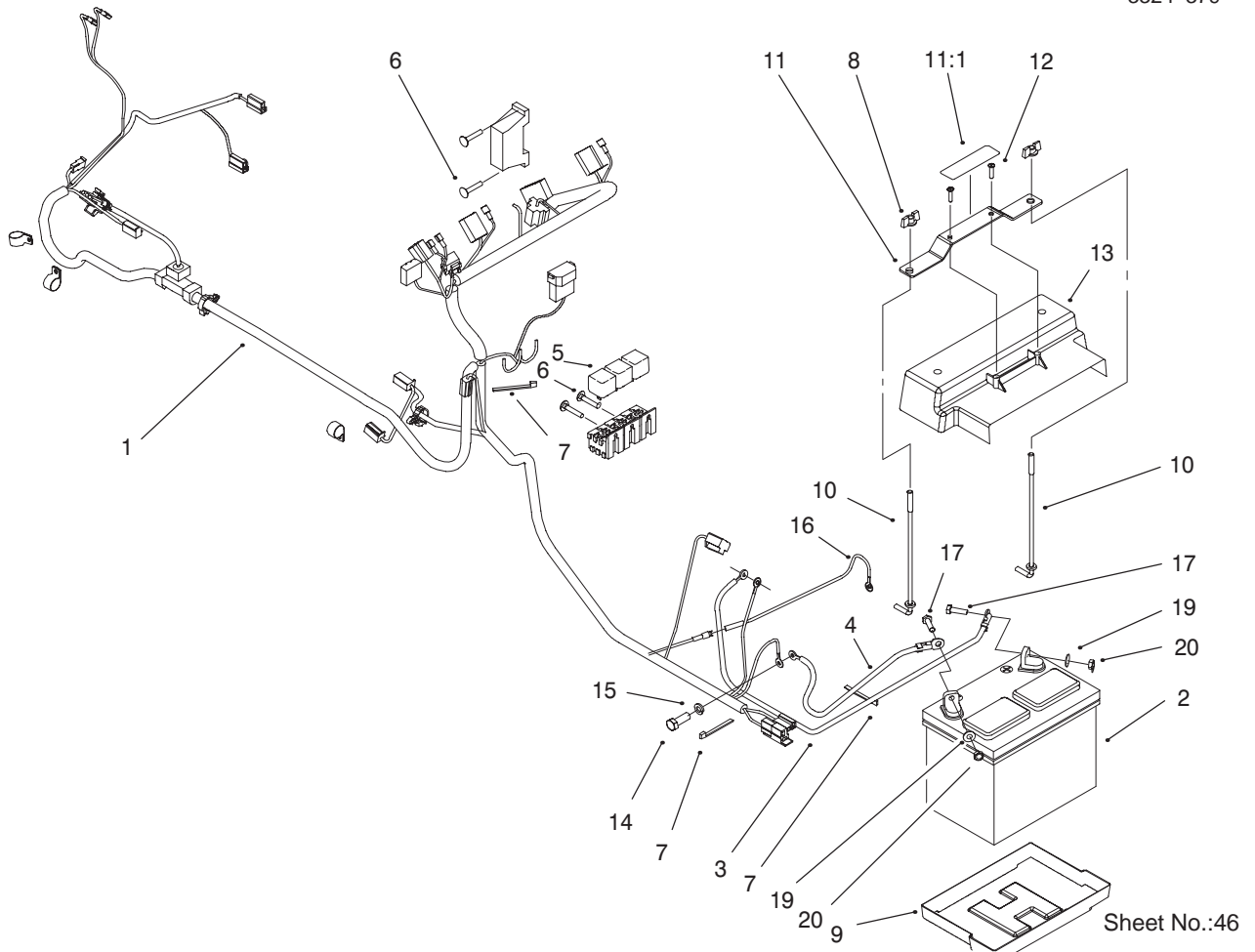

Sheet No.:46

## Electrical Assembly (Model Nos. 73542, & 73570 Only)

Ref. No.	Part No.	Qty.	Description
1	99-3723	1	Wire Harness-20/22 HP (only on: 73542, 73570)
2	94-1867	1	Battery (only on: 73542, 73570)
3	95-7854	1	Cable - Battery, Red 27" (only on: 73542, 73570)
4	95-7873	1	Cable - Battery (only on: 73542, 73570)
5	98-7249	3	Relay-Speedometer (only on: 73542, 73570)
6	12-5450	4	Screw (only on: 73542, 73570)
7	614249	2	Tie Strap (only on: 73542, 73570)
8	32103-22	2	Nut-Wing (only on: 73542, 73570)
9	106948	1	Tray-Battery (only on: 73542, 73570)
10	95-4042	2	Hook-Battery Retain (only on: 73542, 73570)

Ref. No.	Part No.	Qty.	Description
11	98-5056	1	Assembly - Strap w/Decal (only on: 73542, 73570)
11:1	93-1265	1	Decal - Hot Surface (only on: 73542, 73570)
12	94-4496	2	Screw-PPH (only on: 73542, 73570)
13	95-4044	1	Shield - Battery (only on: 73542)
13	95-4092	1	Shield - Battery (Int'l) (only on: 73570)
14	33104-020	1	Screw-HHF (only on: 73542, 73570)
15	3253-4	1	Washer (only on: 73542, 73570)
16	98-1492	1	Wire Harness - Kohler (only on: 73542, 73570)
17	321-5	2	Screw-HH (only on: 73542, 73570)
19	3256-22	2	Washer-Flat (only on: 73542, 73570)
20	3296-42	2	Nut-Lock (only on: 73542, 73570)

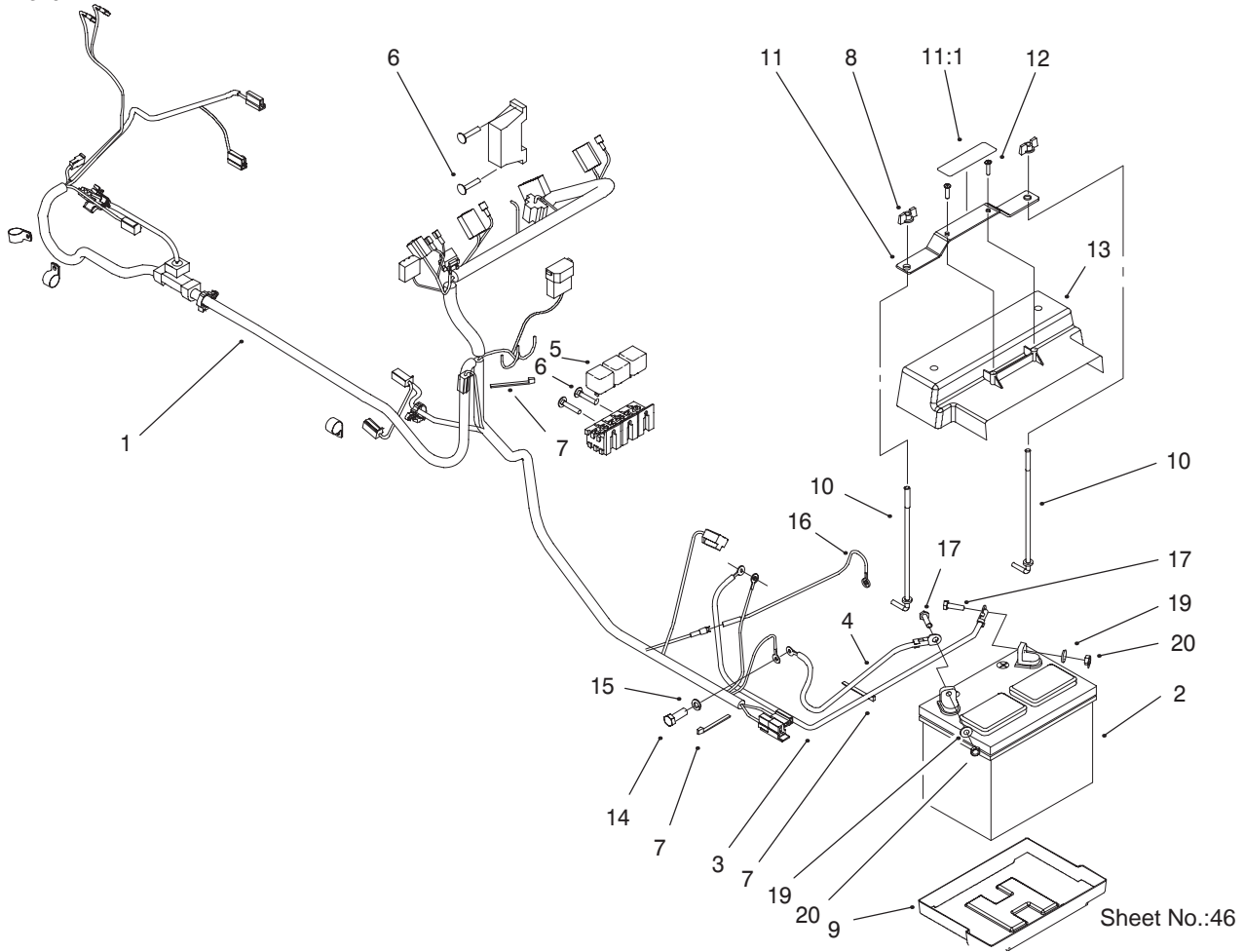

Sheet No.:46

### Electrical Assembly (Model Nos. 73542, & 73570 Only)

Ref. No.	Part No.	Qty.	Description
*	109102	1	Fuse-,25 Amp (only on: 73542, 73570)
*	218-578	2	Fuse-10 Amp Blade Type (only on: 73542, 73570)
*	Nn10277	1	Fuse-30 Amp (only on: 73542, 73570)

Ref. No.	Part No.	Qty.	Description

\*Not illustrated

# Wiring Diagram 18HP

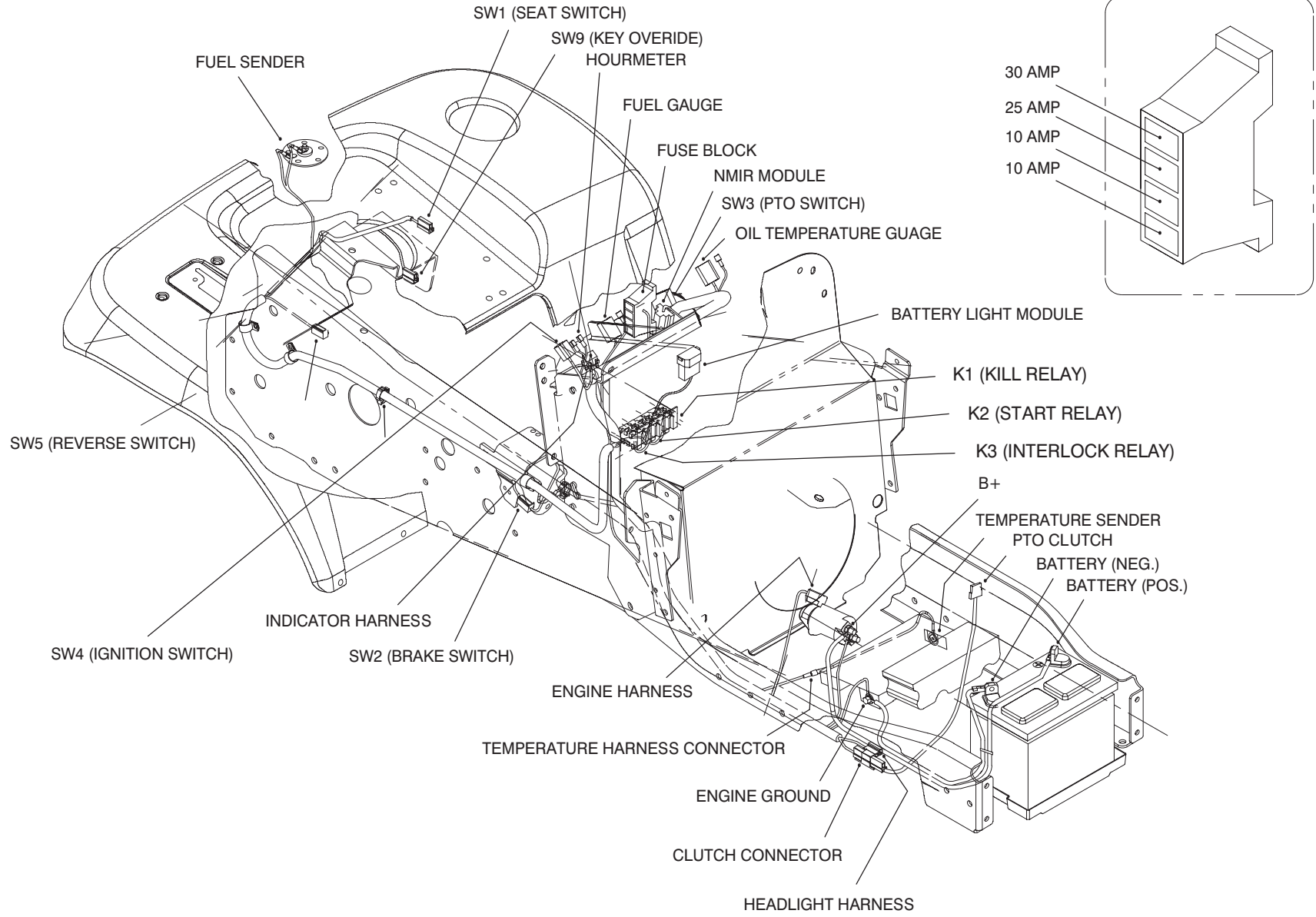

# Wiring Schematic 18HP

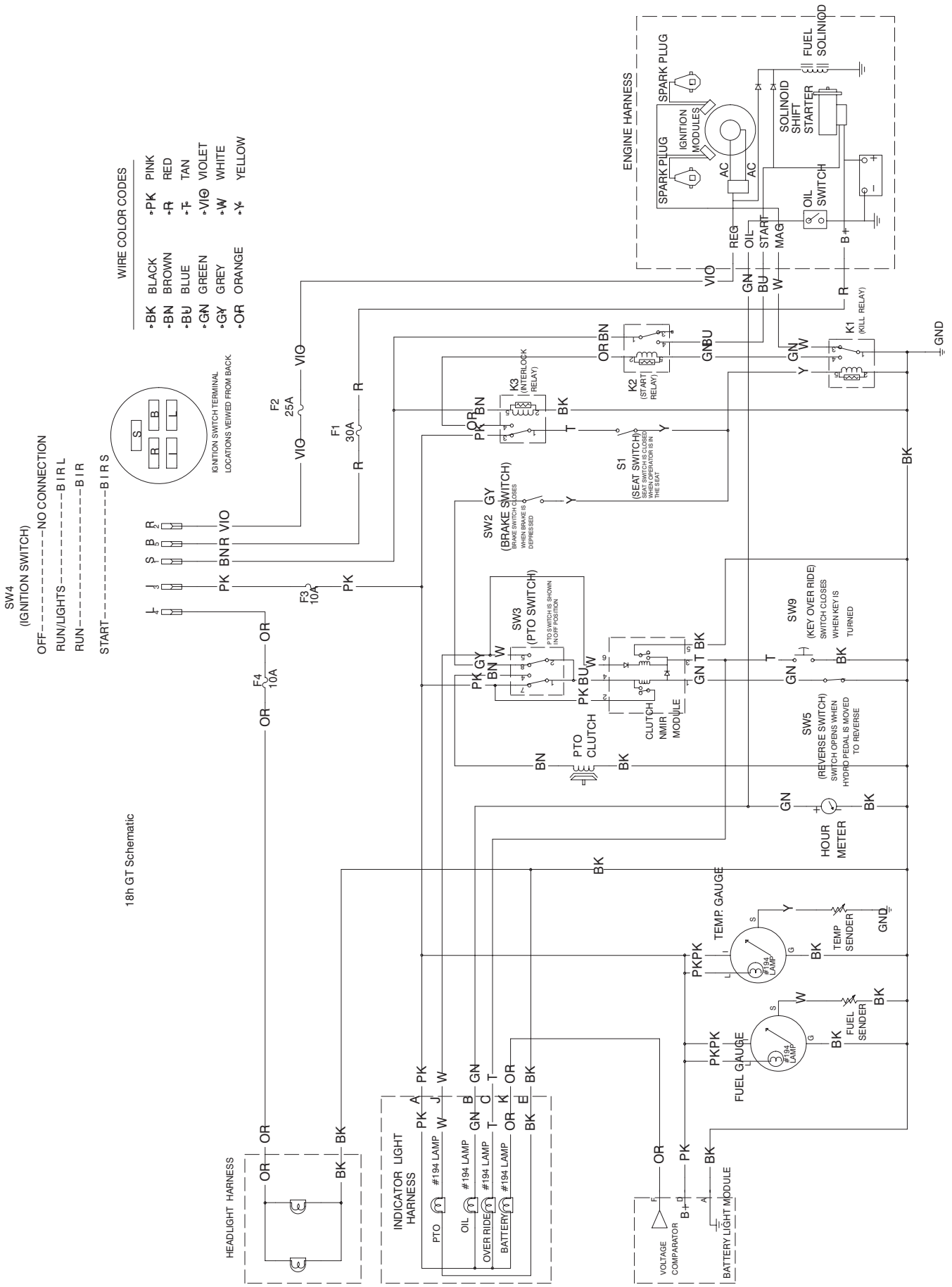

WIRE COLOR CODES

•BK	BLACK	•PK	PINK
•BN	BROWN	•R	RED
•BU	BLUE	•T	TAN
•GN	GREEN	•VIO	VIOLET
•GY	GREY	•W	WHITE
•OR	ORANGE	•Y	YELLOW

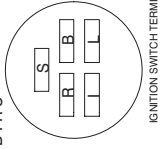

SW4 (IGNITION SWITCH)  
 OFF-----NO CONNECTION  
 RUN/LIGHTS-----B I R L  
 RUN-----B I R  
 START-----B I R S

18h GT Schematic



# Wiring Schematic 20HP

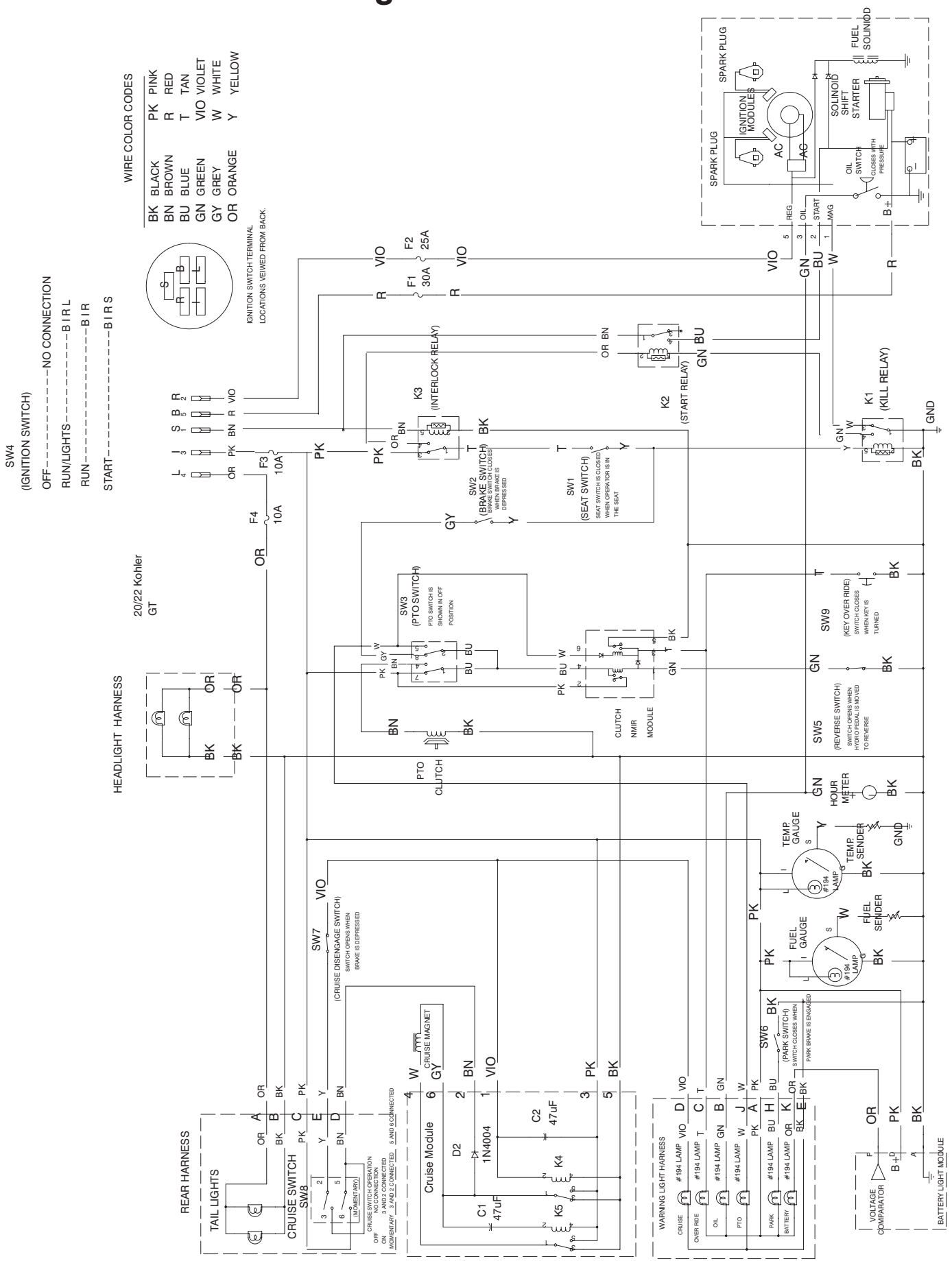

**WIRE COLOR CODES**

BK	BLACK	PK	PINK
BN	BROWN	R	RED
BU	BLUE	T	TAN
GN	GREEN	VIO	VIOLET
GR	GREY	W	WHITE
OR	ORANGE	Y	YELLOW

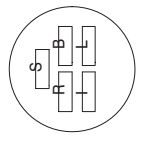

SW4 (IGNITION SWITCH)  
 OFF-----NO CONNECTION  
 RUN/LIGHTS-----B I R L  
 RUN-----B I R  
 START-----B I R S

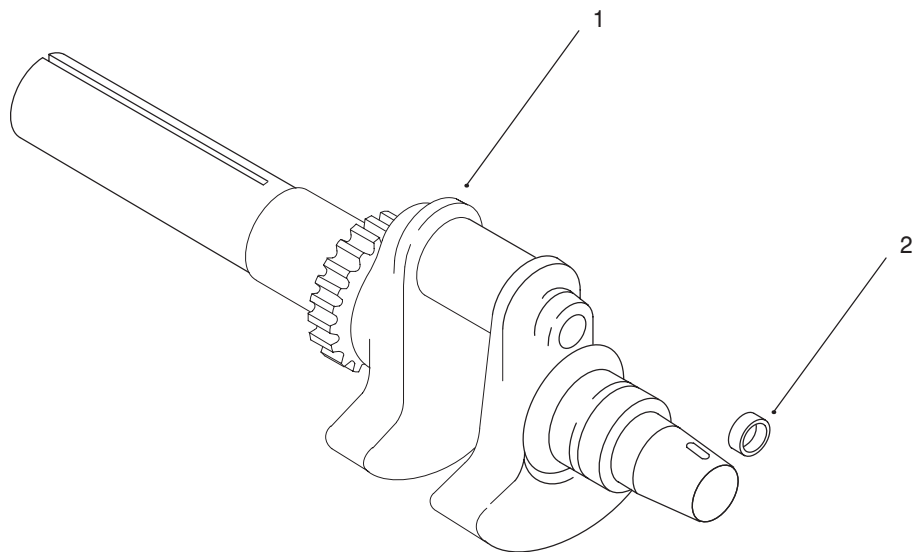

### Group 1 – Crankshaft (Model 73471 Only)

Ref. No.	Part No.	Description	No. Used
1	24 014 14	Crankshaft	2
2	52 139 09	Plug, cup	1

Ref. No.	Part No.	Description	No. Used

**Obtain Parts From Your Local Kohler Dealer**  
 Kohler Engine #CH18S-62579

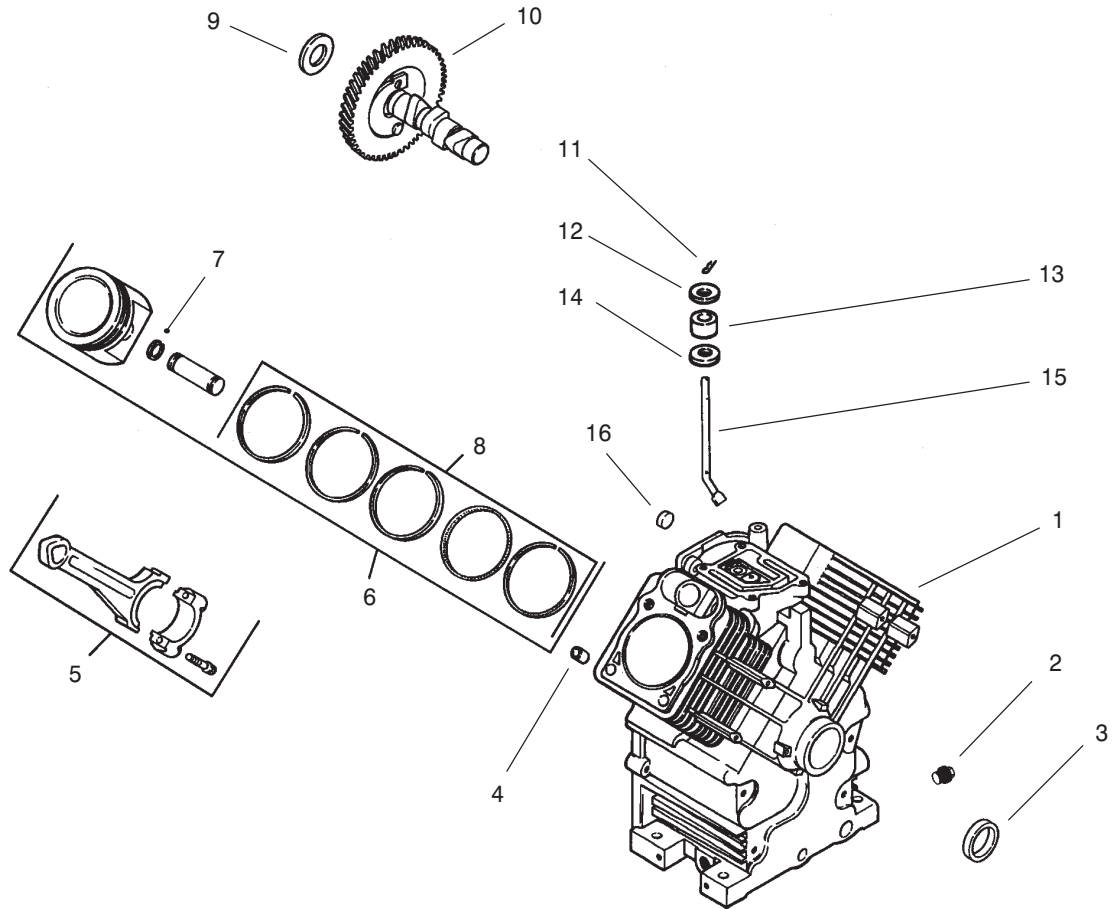

### Group 2 – Crankcase (Model 73471 Only)

Ref. No.	Part No.	Description	No. Used
1		Cylinder Block (Use Miniblock 24 782 01)	1
2	X-75-10	Plug, hex. head	2
3	24 032 01	Seal, oil front	1
4	12 380 17	Pin, dowel locating	6
5	24 067 09	Connecting Rod (Std.)	2
	24 067 10	Connecting Rod (.25)	2
6	24 874 01	Piston w/Ring Set (Std.)	2
	24 874 02	Piston w/Ring Set (.25)	2
	24 874 03	Piston w/Ring Set (.50)	2
7	24 018 01	Retainer, piston pin	4
8	24 108 01	Ring Set (Std.)	2
	24 108 02	Ring Set (.25)	2
	24 108 03	Ring Set (.50)	2

Ref. No.	Part No.	Description	No. Used
9	12 422 09	Shim, camshaft red	A/R
	12 422 13	Shim, camshaft black	A/R
	12 422 07	Shim, camshaft white	A/R
	12 422 08	Shim, camshaft blue	A/R
	12 422 10	Shim, camshaft yellow	A/R
	12 422 11	Shim, camshaft green	A/R
	12 422 12	Shim, camshaft gray	A/R
10	24 012 05	Camshaft	1
11	12 380 04	Pin, hitch	1
12	M-0631005	Washer, flat	1
13	12 032 01	Seal, governor cross shaft	1
14	X-25-102	Washer	1
15	24 144 01	Shaft, governor cross	1
16	52 139 09	Plug, cup	1

Obtain Parts From Your Local Kohler Dealer  
Kohler Engine #CH18S-62579

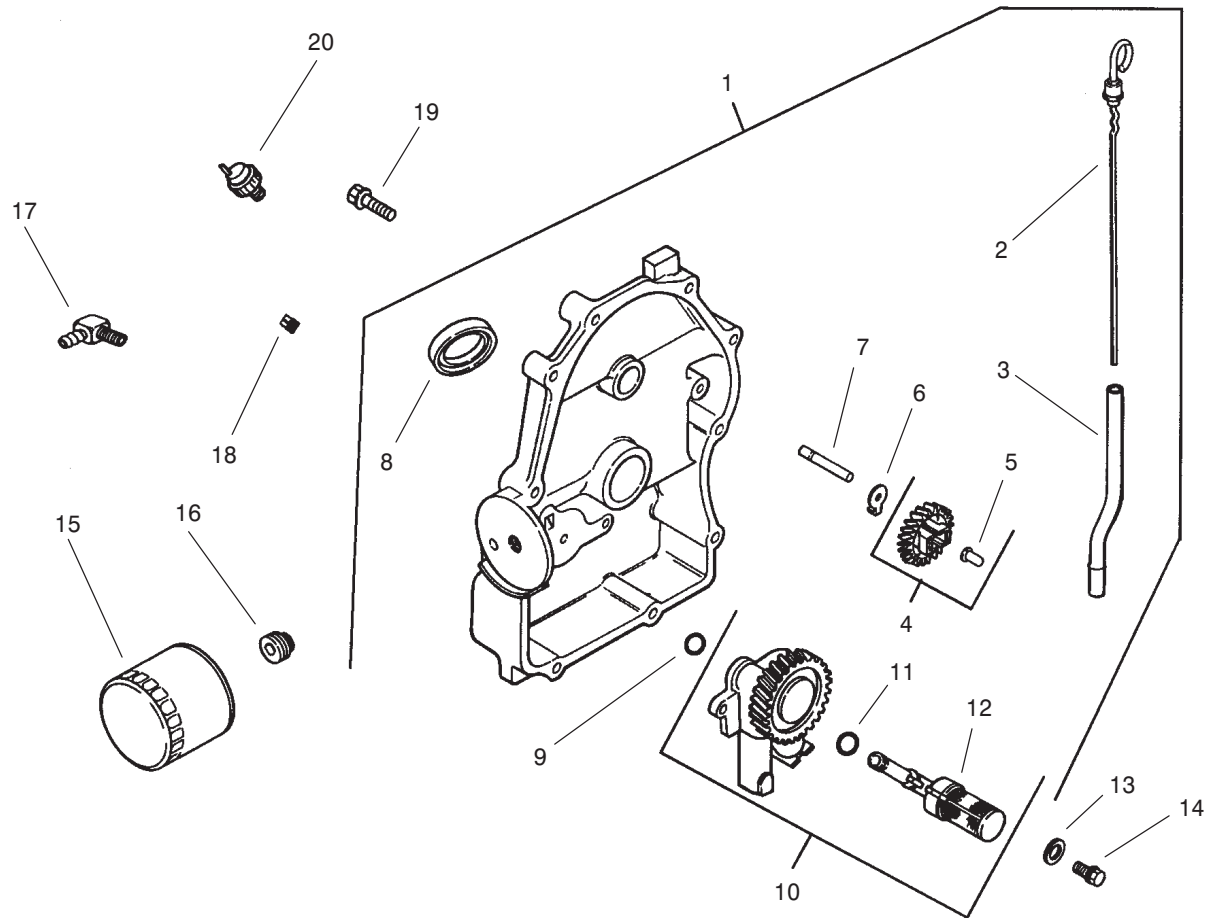

### Group 3 – Oil Pan Lubrication (Model 73471 Only)

Ref. No.	Part No.	Description	No. Used	Ref. No.	Part No.	Description	No. Used
1	54 009 01	Plate, closure assembly (Includes 2–12)	1	11	24 153 01	O–Ring, oil pick–up	1
2	24 038 06	Dipstick	1	12	24 381 04	Pick–up, oil	1
3	24 123 08	Tube, dipstick	1	13	M–0631005	Washer	2
4	24 043 12	Kit, governor gear (Includes 5)	1	14	M–0645025	Screw, hex. flange	2
5	12 380 01	Pin, governor regulating	1	15	12 050 01	Filter, oil	1
6	52 448 02	Tab, locking	1	16	24 136 01	Nipple, oil filter	1
7	12 144 02	Shaft, governor gear	1	17	25 155 02	Connector	1
8	52 032 08	Seal, oil (PTO end)	1	18	X–75–23	Plug, pipe	1
9	24 153 08	O–Ring	1	19	24 086 16	Screw, hex. flange	10
10	24 393 10	Oil pump assembly (Includes 11–12)	1	20	52 099 06	Switch, pressure	1
						<b>Not Illustrated</b>	
					25 113 05	Decal, oil sentry	1

Obtain Parts From Your Local Kohler Dealer  
Kohler Engine #CH18S–62579

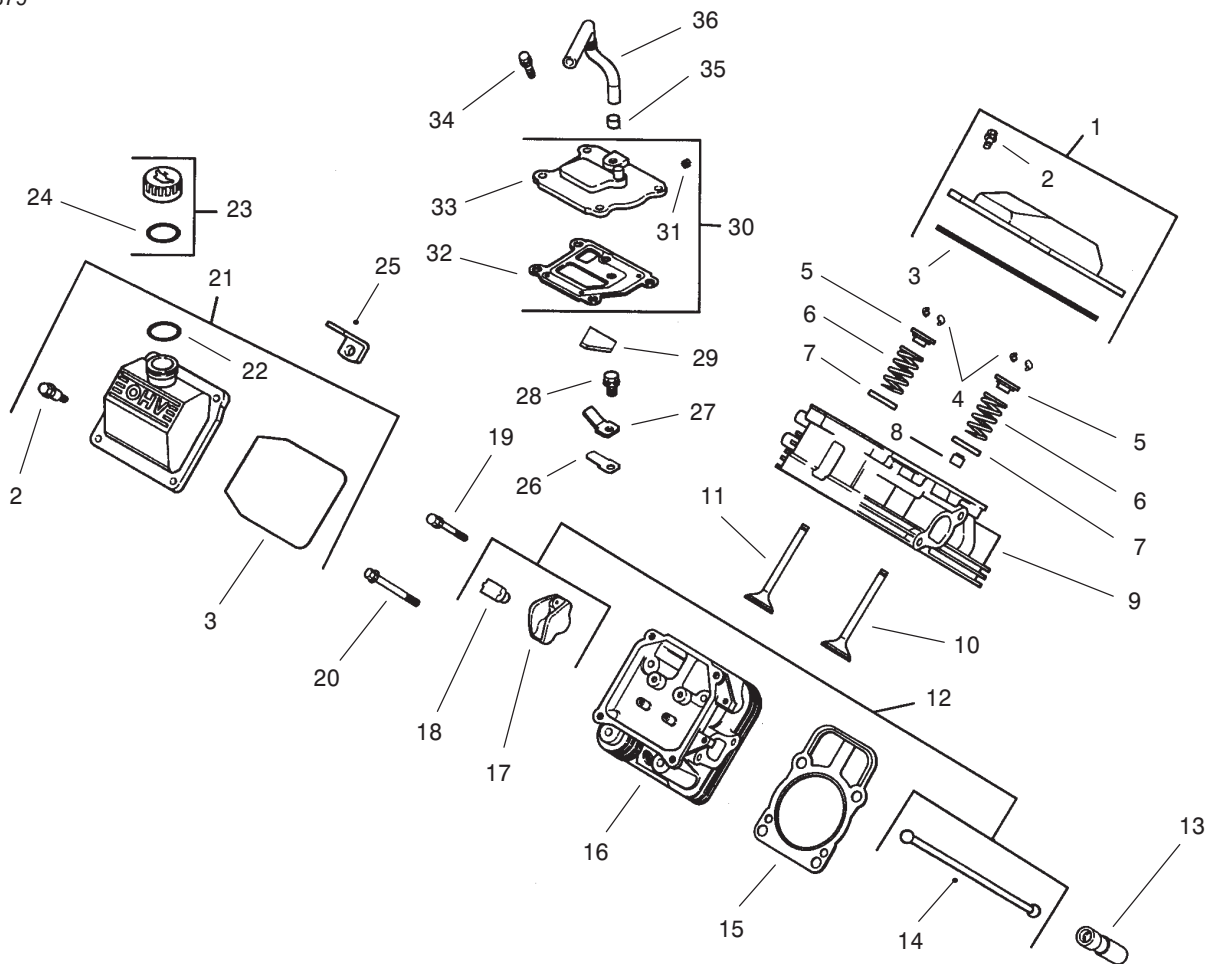

### Group 4 – Head/Valve/Breather (Model 73471 Only)

Ref. No.	Part No.	Description	No. Used
1	24 755 74	Kit, valve cover – plain (Includes 2-3)	1
2	24 086 32	Screw, shoulder	4
3	24 153 16	O-Ring, valve cover	1
4	12 755 03	Kit, retainer	4
5	12 173 01	Cap, valve spring	4
6	24 089 02	Spring, valve	4
7	235011	Retainer, spring	4
8	24 032 05	Seal, valve stem	2
9	24 318 09	Head assembly, #1 cylinder	1
10	24 017 01	Valve, intake ( Std.)	2
	24 017 02	Valve, intake (.25)	2
11	24 016 01	Valve, exhaust (Std.)	2
	24 016 02	Valve, exhaust (.25)	2
12	24 755 66	Kit, valve train (Includes 14,17,18)	1
13	12 351 02	Lifter, valve	4
14	24 411 05	Rod, push	4
15	24 041 08	Gasket, cylinder head	2
16	24 318 10	Head assembly, #2 cylinder	1
17	25 186 01	Arm, rocker	4

Ref. No.	Part No.	Description	No. Used
18	24 599 01	Pivot, rocker arm	4
19	M-0640034	Screw, hex. flange	4
20	12 086 16	Screw, hex. flange	8
21	24 755 75	Kit, valve cover – oil fill (Includes 2,3,22)	1
22	24 153 09	O-Ring	1
23	25 755 13	Kit, oil fill cap (Includes 24)	1
24	12 153 03	O-Ring, oil fill cap	1
25	24 445 01	Strap, lifting	1
26	24 402 03	Reed, breather	1
27	12 018 01	Retainer, breather reed	1
28	M-0545010	Screw, hex. flange	1
29	24 050 01	Filter, breather	1
30	24 033 01	Kit, breather (Includes 31-33)	1
31	X-75-23	Plug, allen head	1
32	24 041 23	Gasket, breather	1
33	24 096 02	Cover, breather	1
34	M-0645020	Screw, hex. flange	4
35	X-426-9	Clamp, breather	1
36	24 326 06	Hose, breather	1

Obtain Parts From Your Local Kohler Dealer

Kohler Engine #CH18S-62579

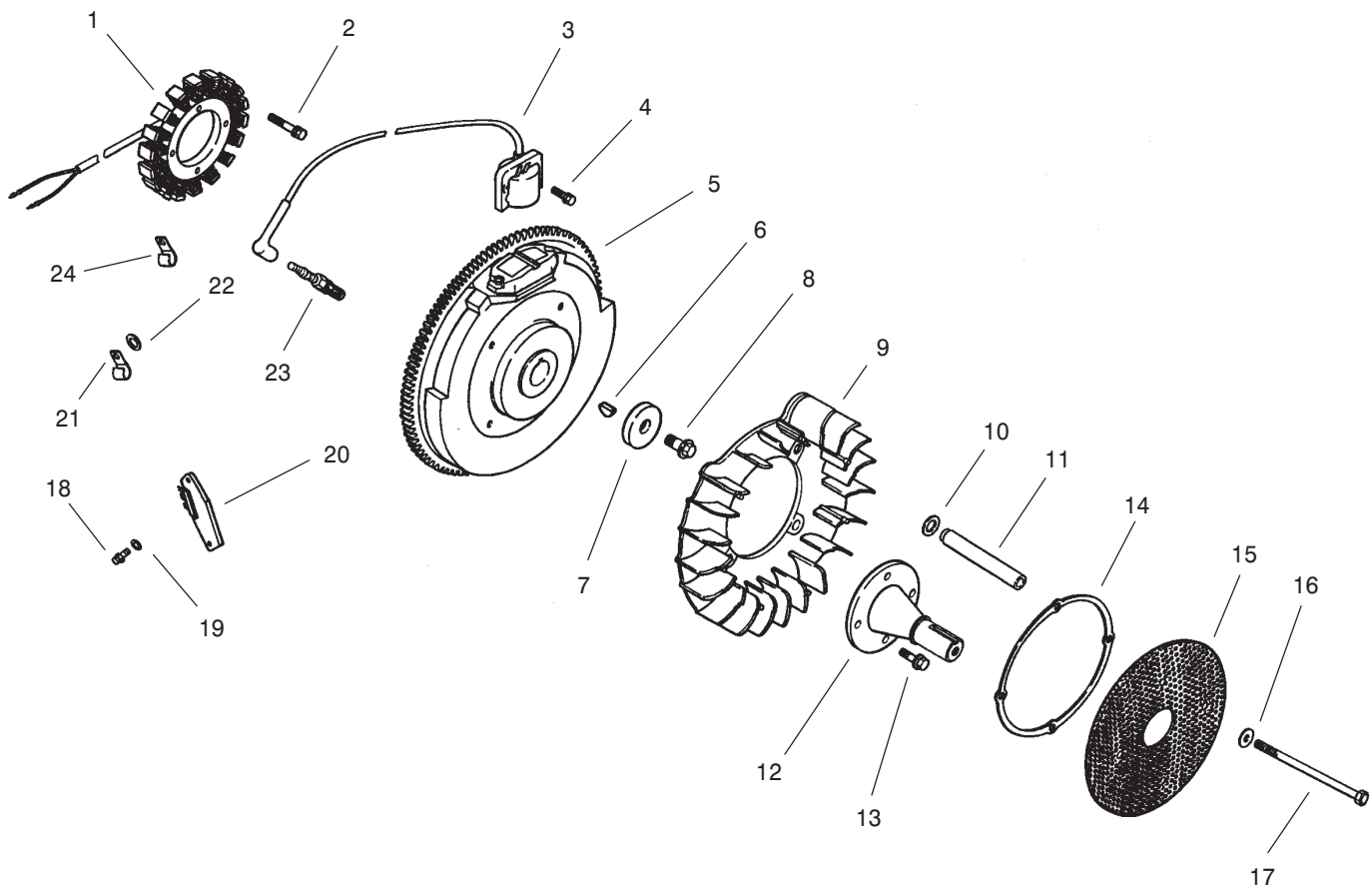

### Group 5 – Ignition/Electrical (Model 73471 Only)

Ref. No.	Part No.	Description	No. Used
1	24 085 03	Kit, 15 amp stator (Incl. 24 126 71 bracket)	1
2	M-0548025	Screw, hex. cap	2
3	24 584 01	Module, ignition	2
4	M-0545020	Screw, hex. flange	4
5	24 025 01	Flywheel	1
6	X-42-15	Key	1
7	12 468 03	Washer	1
8	12 086 14	Screw, hex. flange	1
9	24 157 03	Fan	1
10	24 468 11	Washer, spring	4
11	24 112 14	Spacer, grass screen	4
12	24 144 25	Shaft, front drive	1
13	M-0839025	Screw, hex. flange	4
14	24 141 06	Ring, support	1
15	24 162 22	Screen, grass	1
16	X-25-53	Washer, plain	4
17	M-0603100	Screw, hex. cap	4
18	24 086 18	Screw, phillips head	2
19	X-25-92	Washer	2
20	25 403 03	Rectifier-regulator 15 amp	1
21	235173	Clip, cable	1
22	X-25-63	Washer	1

Ref. No.	Part No.	Description	No. Used
23	12 132 02	Spark Plug	2
24	48 154 02	Clip, cable	1
		<b>Not Illustrated</b>	
	25 518 28	Lead, black, (4" - 18 gauge - insulated grip barrel eyelet terminals)	1
	24 176 08	Harness, wiring	1
	24 176 49	Harness, wiring (Includes 3 connectors)	1
	236602	Connector	1
	15 155 01	Connector	1
	52 155 04	Connector	1
	24 126 71	Bracket, stator wire	1
	25 086 43	Screw, set (adjusts grass scraper blade)	1
	X-22-11	Washer, lock(for ground screw & wire)	1
	41 155 03	Connector	1
	277563	Connector	1
	X-67-3	Screw (mounts 5 wire connector to baffle)	2

Obtain Parts From Your Local Kohler Dealer  
Kohler Engine #CH18S-62579

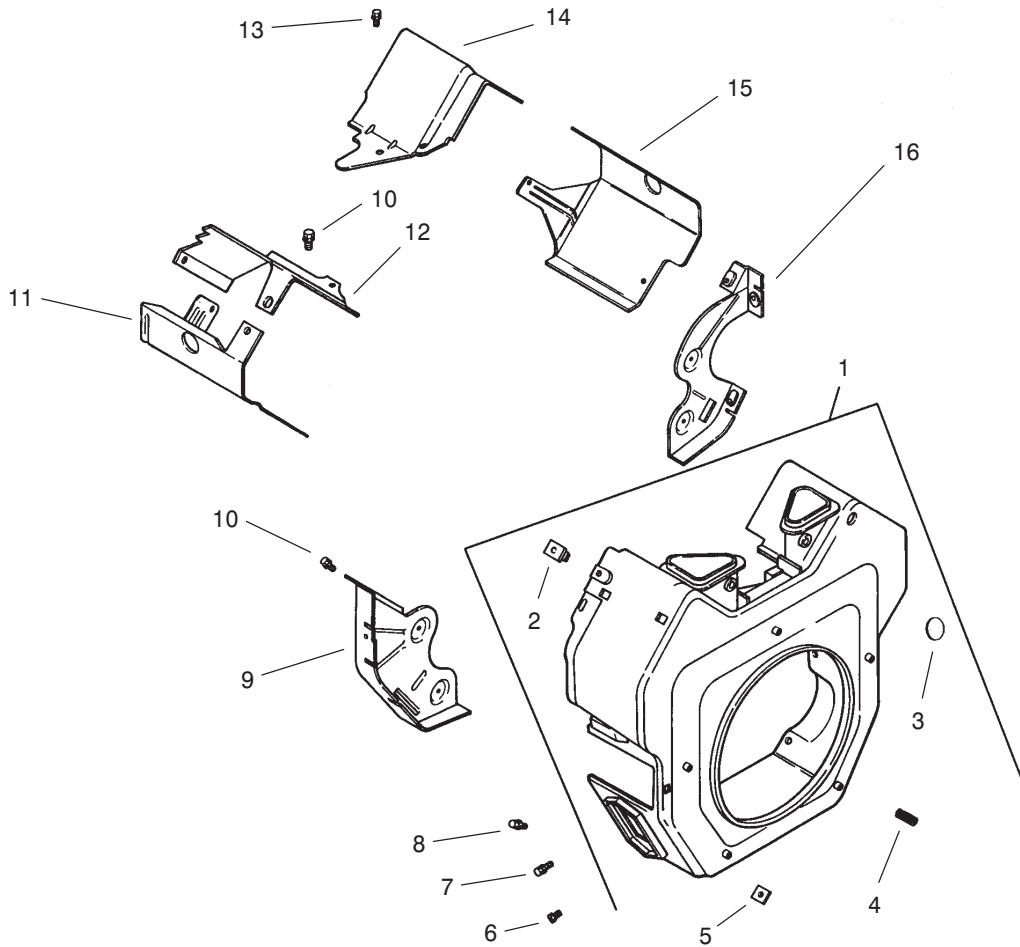

### Group 6 – Blower Housing & Baffles (Model 73471 Only)

Ref. No.	Part No.	Description	No. Used
1	24 027 83	Housing, blower (Includes 2-5)	1
2	24 100 02	Nut, plastic	2
3	24 755 90	Kit, button plug	1
4	24 086 43	Screw, set	1
5	24 100 01	Nut, plastic	2
6	M-0551016	Screw, hex. flange	1
7	M-0545016	Screw, hex. flange	5
8	M-0545020	Screw, hex. flange	2
9	24 146 02	Plate, backing - #2 side	1

Ref. No.	Part No.	Description	No. Used
10	M-0645016	Screw, hex. flange	6
11	24 063 20	Baffle, cyl. barrel-#2 side	1
12	24 063 17	Baffle, valley - #2 side	1
13	M-0545010	Screw, hex. flange	2
14	24 063 24	Baffle, valley - #1 side	1
15	24 063 30	Baffle, cyl. barrel-#1 side	1
16	24 146 08	Plate, backing - #1 side	1
		<b>Not Illustrated</b>	1
	24 113 11	Decal, HP	1

Obtain Parts From Your Local Kohler Dealer  
Kohler Engine #CH18S-62579

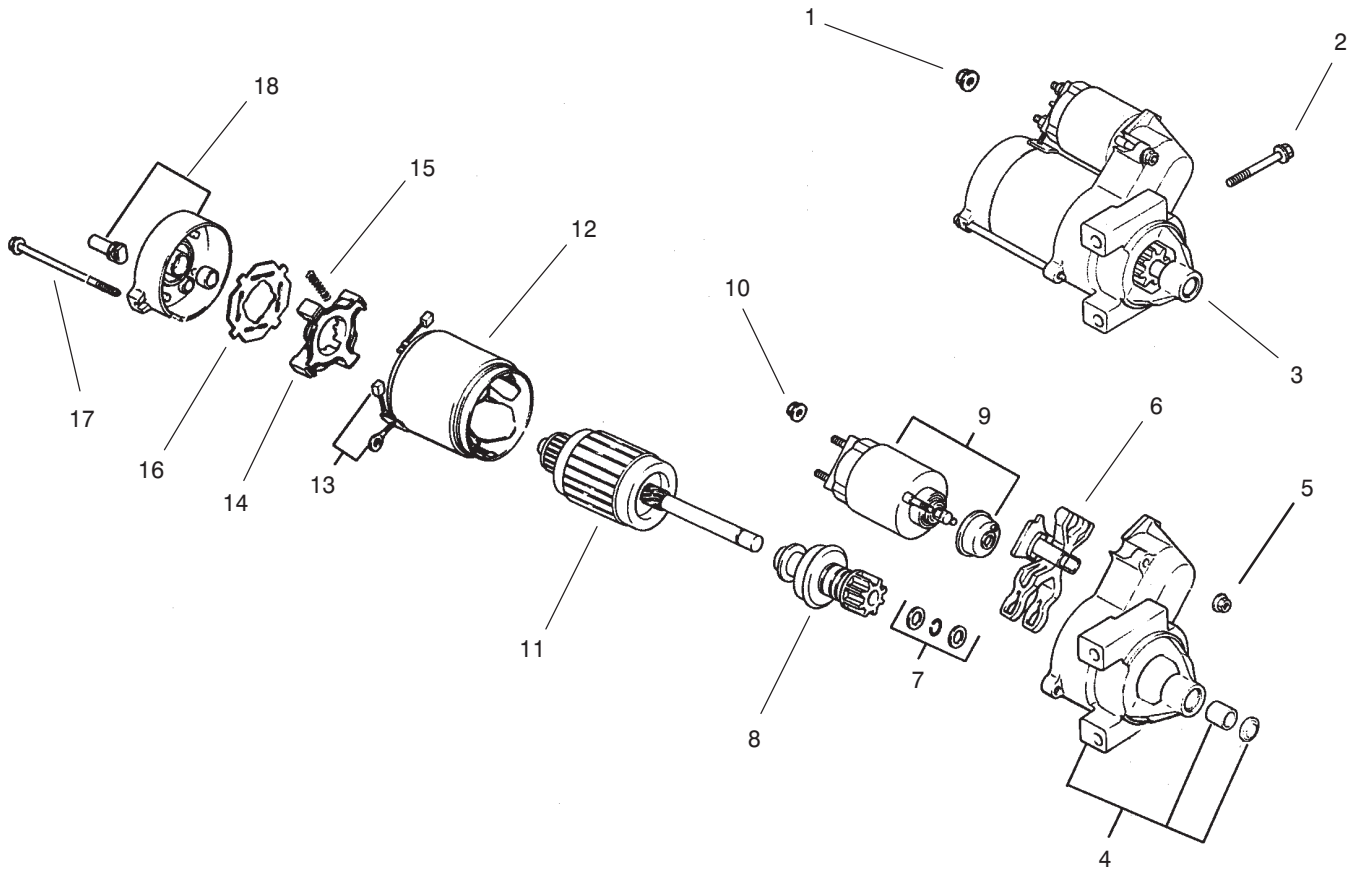

## Group 7 – Starting System (Model 73471 Only)

Ref. No.	Part No.	Description	No. Used
1	M-0841080	Nut, hex flange	1
2	M-0839080	Screw, hex. flange	2
3	24 098 01	Starter, solenoid shift assembly (Incl. 4-18)	1
4	24 081 04	Drive, end cap	1
5	52 100 10	Nut, starter	2
6	12 090 10	Lever, starter drive	1
7	24 755 84	Kit, starter repair	1
8	12 239 01	Drive, pinion	1
9	52 435 02	Solenoid	1

Ref. No.	Part No.	Description	No. Used
10	52 100 09	Nut, starter	1
11	12 170 04	Armature, starter	1
12	12 471 01	Frame	1
13	52 221 01	Kit, brush & spring (Includes 15)	1
14	52 323 03	Holder, brush	1
15	52 089 09	Spring, brush	4
16	52 168 01	Insulator	1
17	52 211 05	Bolt, thru	2
18	24 301 01	Commutator, end cap	1

Obtain Parts From Your Local Kohler Dealer  
Kohler Engine #CH18S-62579

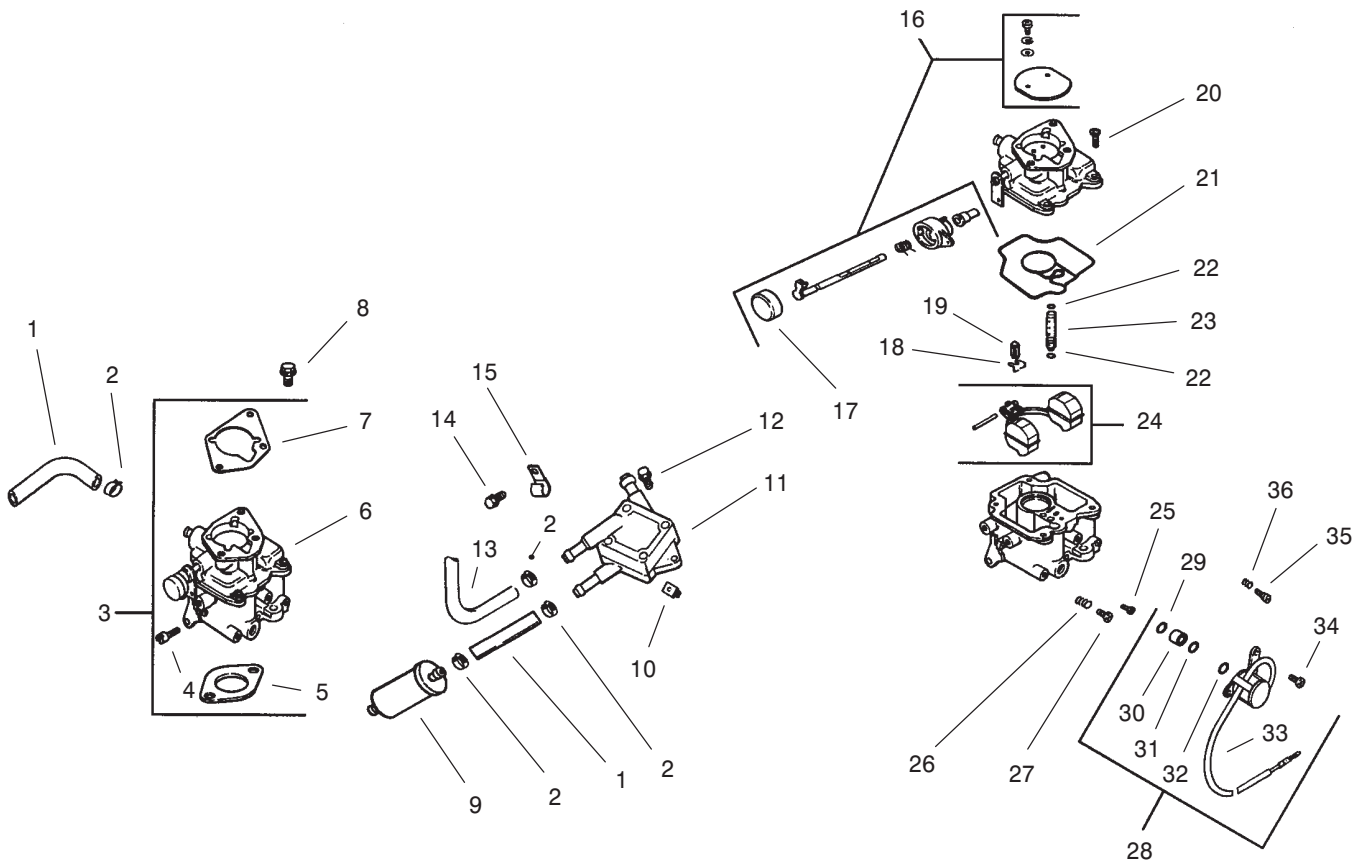

### Group 8 – Fuel System (Model 73471 Only)

Ref. No.	Part No.	Description	No. Used
1	25 353 10	Line, fuel 9"	2
2	X-426-9	Clamp, hose	6
3	24 853 35	Kit, carburetor w/gasket (Includes 4-7)	1
4	24 086 05	Screw, throttle stop	1
5	24 041 06	Gasket, air cleaner base	1
6	24 053 32	Carburetor assembly (Includes 16-36, carburetor repair kit 24 757 03)	1
7	24 041 17	Gasket, carburetor	1
8	M-0651030	Screw, hex. flange	2
9	24 050 02	Filter, fuel	1
10	24 100 01	Nut, plastic	2
11	24 393 04	Pump, fuel – pulse	1
12	24 086 12	Screw, hex. cap	2
13	24 353 04	Line, fuel 17"	1
14	M-0650012	Screw, hex. flange	1
15	47 154 01	Clip, cable	1
16	24 757 07	Kit, choke repair (Includes 17)	1
17	24 173 02	Cap, choke lever	1
18	24 154 01	Clip, inlet needle valve	1

Ref. No.	Part No.	Description	No. Used
19	24 462 01	Valve, inlet needle	1
20	24 086 09	Screw, carburetor body	4
21	24 041 09	Gasket, carburetor body	1
22	24 153 02	O-Ring, slow jet	2
23	24 337 01	Jet, slow	1
24	24 757 02	Kit, float repair	1
25	24 337 02	Jet, main	1
26	24 089 10	Spring, idle adjust screw	1
27	24 086 10	Screw, idle adjusting	1
28	24 757 01	Kit, solenoid (Includes 29-34)	1
29	24 153 06	O-Ring	1
30	24 521 01	Seat, solenoid	1
31	24 153 05	O-Ring	1
32	24 153 04	O-Ring	1
33	24 435 01	Solenoid	1
34	24 086 07	Screw, solenoid	2
35	24 368 01	Needle, idle	1
36	24 089 11	Spring, idle needle	1
	24 757 03	<b>Not Illustrated</b> Kit, carburetor repair	1

Obtain Parts From Your Local Kohler Dealer  
Kohler Engine #CH18S-62579

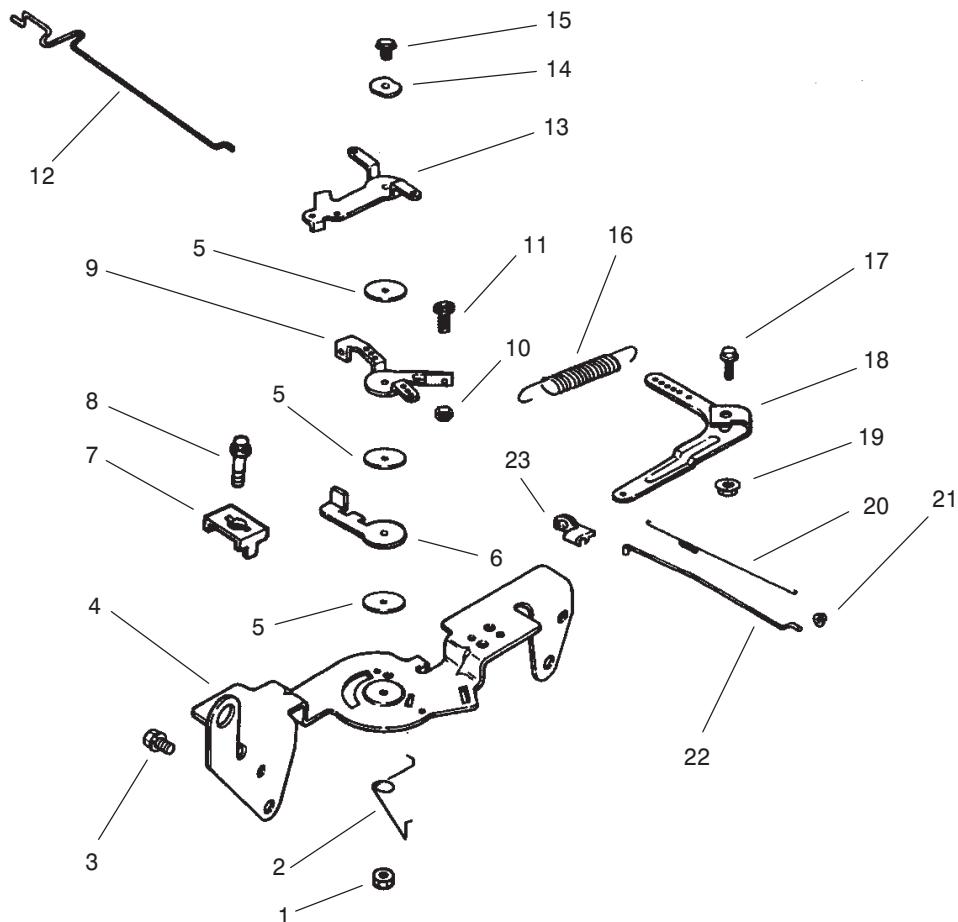

## Group 9 – Engine Controls (Model 73471 Only)

Ref. No.	Part No.	Description	No. Used
1	M-0547050	Nut, hex. lock	1
2	24 089 03	Spring, choke return	1
3	M-0645016	Screw, hex. flange	4
4	24 126 56	Bracket, control	1
5	24 468 01	Washer	3
6	24 090 07	Lever, throttle actuator	1
7	12 237 01	Clamp, cable	2
8	M-0545016	Screw, hex. flange	2
9	24 090 03	Lever, throttle control	1
10	M-0446030	Nut, hex	1
11	M-0401030	Screw, hex. cap	1
12	24 079 02	Linkage, choke	1

Ref. No.	Part No.	Description	No. Used
13	24 090 05	Lever, choke	1
14	41 468 03	Washer, spring	1
15	M-0545020	Screw, hex. flange	1
16	24 089 15	Spring, governor	1
17	SM-0642025	Screw, hex. flange	1
18	24 090 14	Lever, governor	1
19	M-0641060	Nut, hex. flange	1
20	24 089 01	Spring, linkage	1
21	25 158 08	Bushing, linkage retaining	1
22	24 079 01	Linkage, throttle	1
23	25 158 11	Bushing, linkage retaining	1

Obtain Parts From Your Local Kohler Dealer  
Kohler Engine #CH18S-62579

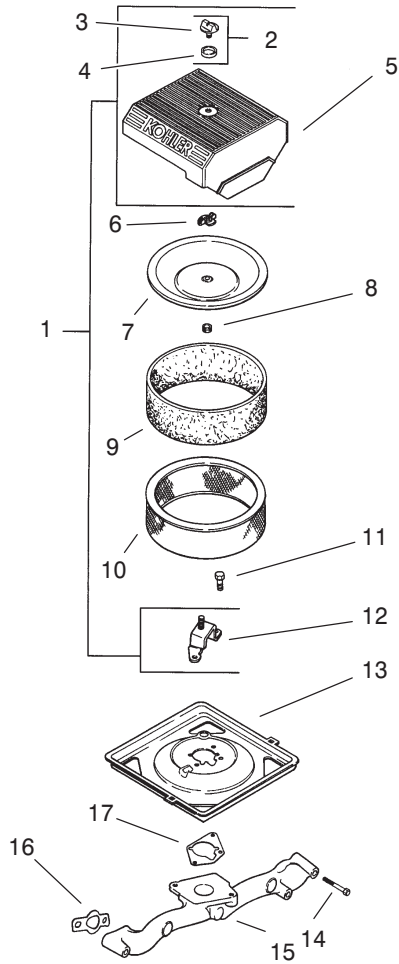

### Group 10 – Air Filter (Model 73471 Only)

Ref. No.	Part No.	Description	No. Used	Ref. No.	Part No.	Description	No. Used
1	24 743 05	Kit, air cleaner cover (Includes 2-5, 12)	1	9	24 083 02	Precleaner, element	1
2	54 755 01	Kit, knob with seal (Includes 3-4)	1	10	47 083 03	Element, air cleaner	1
3	25 341 03	Knob, cover	1	11	M-0639016	Screw, hex. flange	3
4	24 153 15	Seal, air cleaner cover knob	1	12	24 126 21	Bracket, air cleaner base	1
5	24 096 24	Cover, air cleaner	1	13	24 094 03	Base, air cleaner	1
6	12 100 01	Wing Nut	1	14	M-0651055	Screw, hex. flange	4
7	24 096 01	Cover, inner air cleaner	1	15	24 164 14	Manifold, intake	1
8	24 032 03	Seal, inner air cleaner	1	16	24 041 01	Gasket, intake manifold	2
				17	24 041 06	Gasket, air cleaner base	1

**Obtain Parts From Your Local Kohler Dealer**  
 Kohler Engine #CH18S-62579

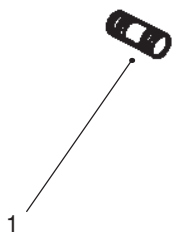

### Group 11 – Exhaust (Model 73471 Only)

Ref. No.	Part No.	Description	No. Used
1	25 072 04	Stud	4
		<b>Not Illustrated</b>	
	24 782 01	Miniblock	1
	24 755 03	Gasket Set	1

Ref. No.	Part No.	Description	No. Used

Obtain Parts From Your Local Kohler Dealer  
 Kohler Engine #CH18S-62579



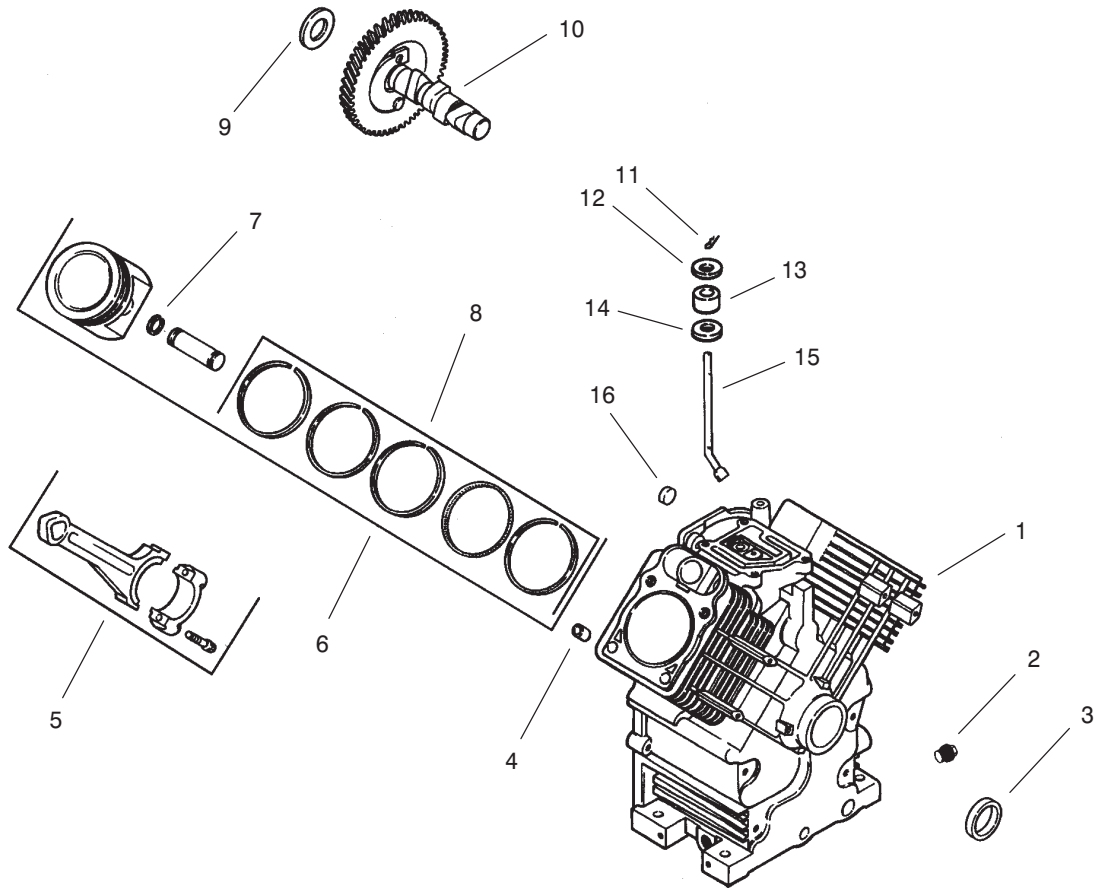

## Group 2 – Crankcase (Models 73542 & 73570)

Ref. No.	Part No.	Description	No. Used
1	X-75-10	Cylinder Block (Use Miniblock 24 782 01)	1
2	24 032 01	Plug, hex. head	2
3	12 380 17	Seal, oil front	1
4		Pin, dowel locating	6
5	24 067 09	Connecting Rod (Std.)	2
	24 067 10	Connecting Rod (.25)	2
6	24 874 01	Piston w/Ring Set (Std.)	2
	24 874 02	Piston w/Ring Set (.25)	2
	24 874 03	Piston w/Ring Set (.50)	2
7	24 018 01	Retainer, piston pin	4
8	24 108 01	Ring Set (Std.)	2
	24 108 02	Ring Set (.25)	2
	24 108 03	Ring Set (.50)	2

Ref. No.	Part No.	Description	No. Used
9	12 422 09	Shim, camshaft red	A/R
	12 422 13	Shim, camshaft black	A/R
	12 422 07	Shim, camshaft white	A/R
	12 422 08	Shim, camshaft blue	A/R
	12 422 10	Shim, camshaft yellow	A/R
	12 422 11	Shim, camshaft green	A/R
	12 422 12	Shim, camshaft gray	A/R
10	24 012 05	Camshaft	1
11	12 380 04	Pin, hitch	1
12	M-0631005	Washer, flat	1
13	12 032 01	Seal, governor cross shaft	1
14	X-25-102	Washer, plain	1
15	24 144 01	Shaft, governor cross	1
16	52 139 09	Plug, cup	1

Obtain Parts From Your Local Kohler Dealer  
Kohler Engine #CH20S-64583

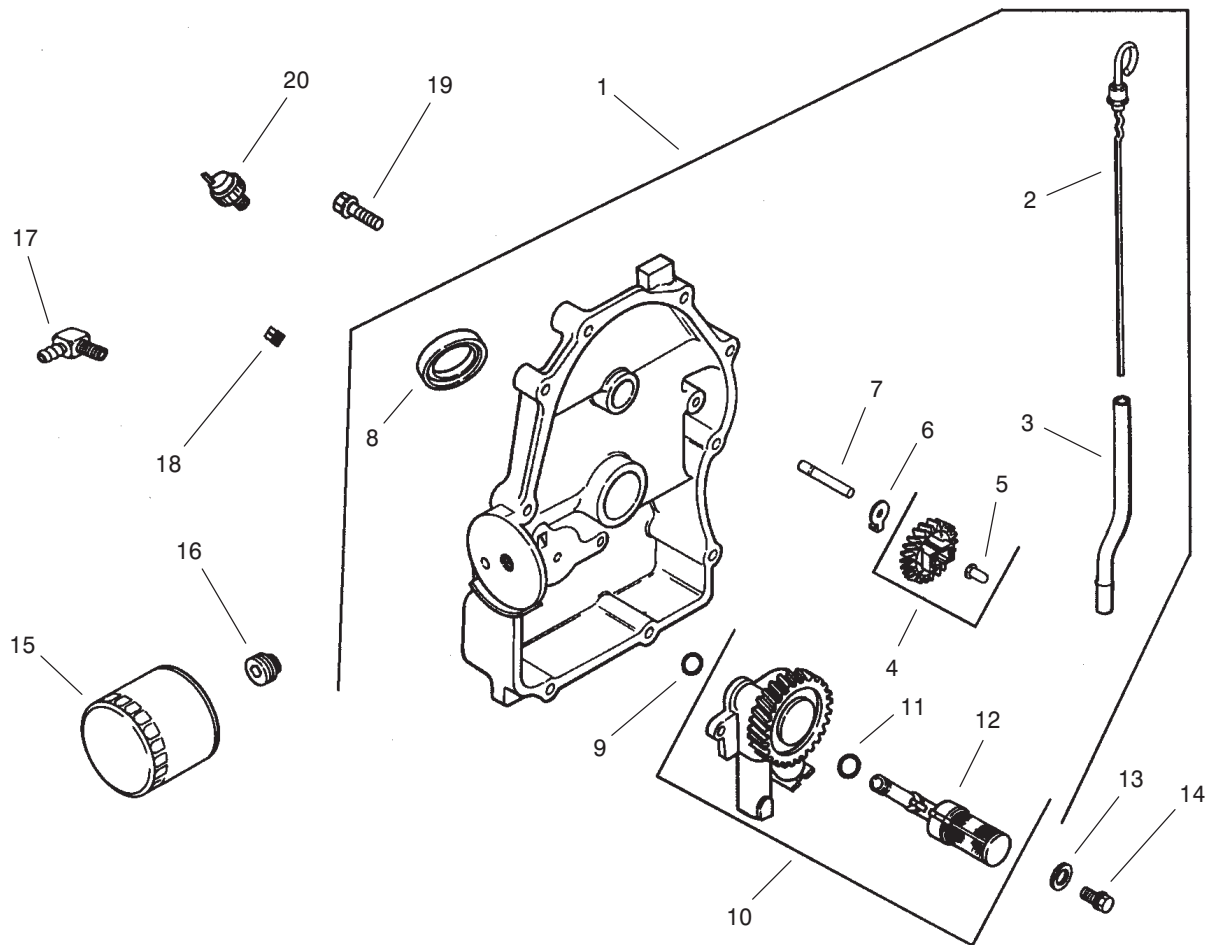

### Group 3 – Oil Pan/Lubrication (Models 73542 & 73570)

Ref. No.	Part No.	Description	No. Used
1	54 009 01	Plate, closure assembly (Includes 2-12)	1
2	24 038 06	Dipstick	1
3	24 123 08	Tube, dipstick	1
4	24 043 12	Kit, governor gear (Includes 5)	1
5	12 380 01	Pin, governor regulating	1
6	52 448 02	Tab, locking	1
7	12 144 02	Shaft, governor gear	1
8	52 032 08	Seal, oil (PTO end)	1
9	24 153 08	O-Ring	1
10	24 393 10	Oil pump assembly (Includes 11,12)	1
11	24 153 01	O-Ring, oil pick-up	1

Ref. No.	Part No.	Description	No. Used
12	24 381 04	Pick-up, oil	1
13	M-0631005	Washer, plain	2
14	M-0645025	Screw, hex. flange	2
15	12 050 01	Filter, oil	1
16	24 136 01	Nipple, oil filter	1
17	25 155 02	Connector	1
18	X-75-23	Plug, pipe	1
19	24 086 16	Screw, hex. flange	10
20	52 099 06	Switch, pressure	1
		<b>Not Illustrated</b>	
	25 113 05	Decal, oil sentry	1

Obtain Parts From Your Local Kohler Dealer  
Kohler Engine #CH20S-64583

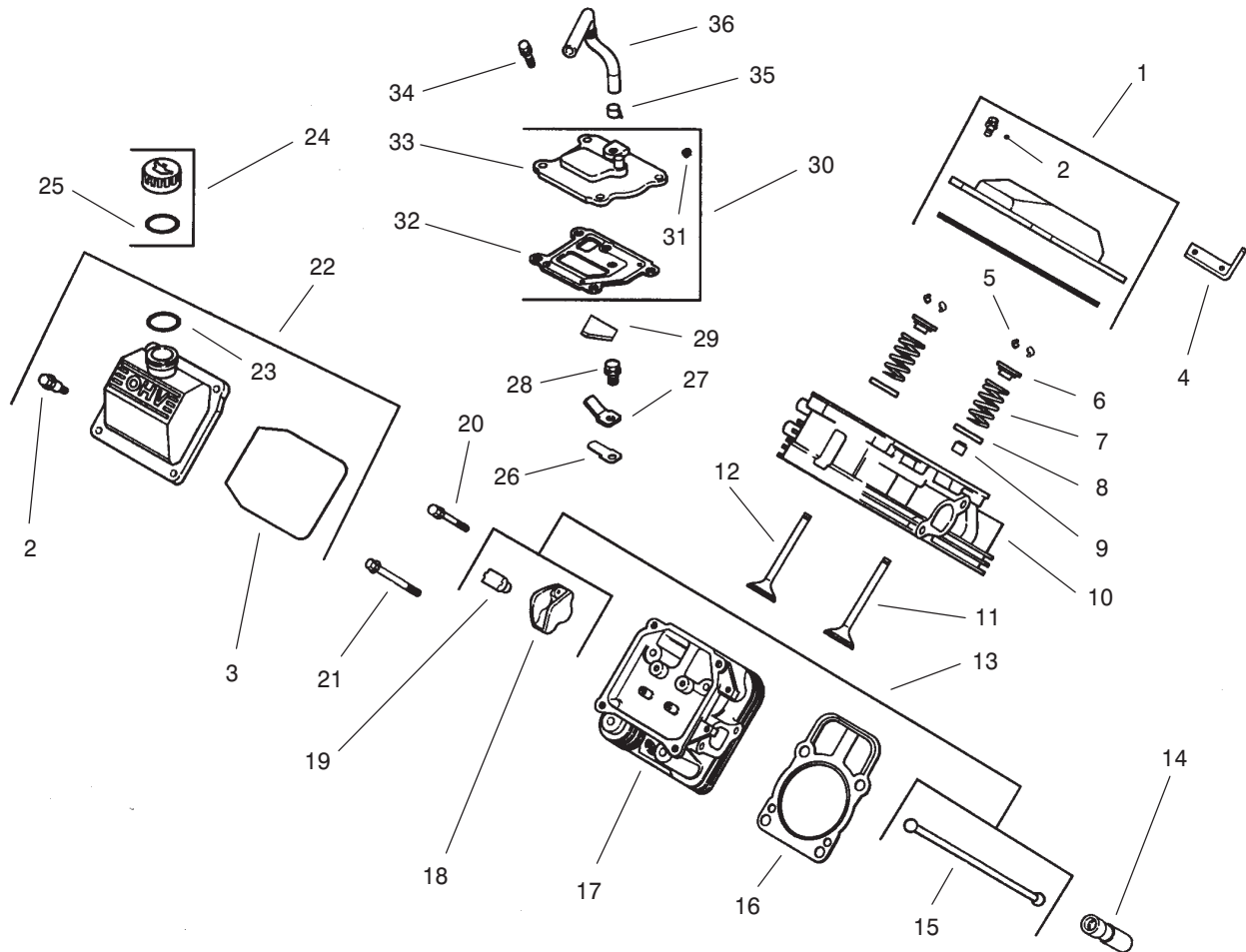

## Group 4 – Head/Valve/Breather (Models 73542 & 73570)

Ref. No.	Part No.	Description	No. Used	Ref. No.	Part No.	Description	No. Used
1	24 755 74	Kit, valve cover – plain (Includes 2-3)	1	18	25 186 01	Arm, rocker	4
2	24 086 32	Screw, shoulder	4	19	24 599 01	Pivot, rocker arm	4
3	24 153 16	O-Ring, valve cover	1	20	M-0640034	Screw, hex. flange	4
4	24 445 01	Strap, lifting	1	21	12 086 16	Screw, hex. flange	8
5	12 755 03	Kit, retainer	4	22	24 755 75	Kit, valve cover – oil fill (Includes 2,3,23)	1
6	12 173 01	Cap, valve spring	4	23	24 153 09	O-Ring	1
7	24 089 02	Spring, valve	4	24	25 755 13	Kit, oil fill cap (Includes 25)	1
8	235011	Retainer, spring	4	25	12 153 03	O-Ring, oil fill cap	1
9	24 032 05	Seal, valve stem	2	26	24 402 03	Reed, breather	1
10	24 318 09	Head assembly, #1 cylinder	1	27	12 018 01	Retainer, breather reed	1
11	24 017 01	Valve, intake (Std.)	2	28	M-0545010	Screw, hex. flange	1
	24 017 02	Valve, intake (.25)	2	29	24 050 01	Filter, breather	1
12	24 016 01	Valve, exhaust (Std.)	2	30	24 033 01	Kit, breather (Includes 31-33)	1
	24 016 02	Valve, exhaust (.25)	2	31	X-75-23	Plug, allen head 1/8 pipe	1
13	24 755 66	Kit, valve train (Includes 15,18,19)	1	32	24 041 23	Gasket, breather	1
14	12 351 02	Lifter, valve	4	33	24 096 02	Cover, breather	1
15	24 411 05	Rod, push	4	34	M-0645020	Screw, hex. flange	4
16	24 041 08	Gasket, cylinder head	2	35	X-426-9	Clamp, breather	1
17	24 318 10	Head assembly, #2 cylinder	1	36	24 326 06	Hose, breather	1

Obtain Parts From Your Local Kohler Dealer  
Kohler Engine #CH20S-64583

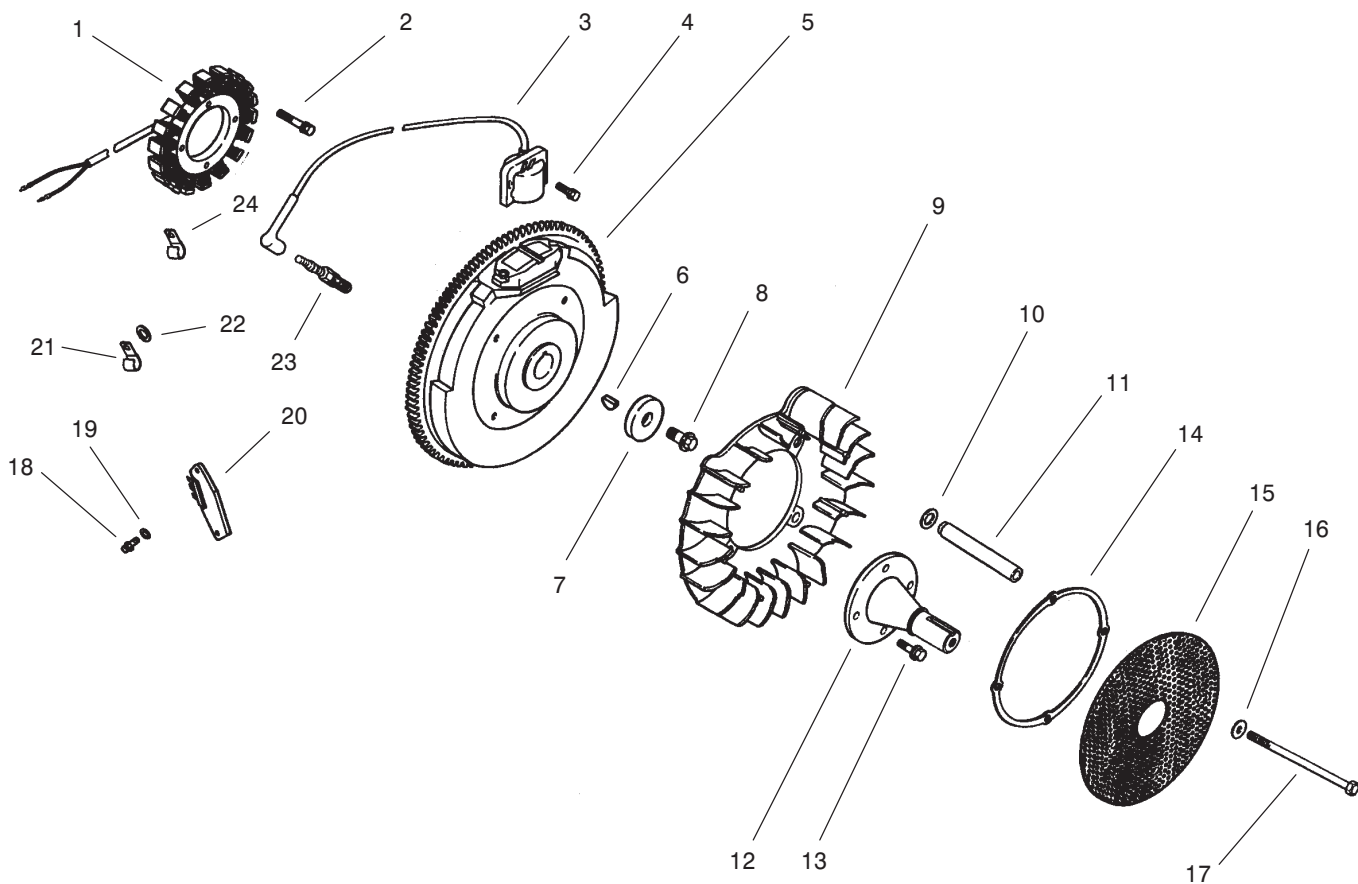

### Group 5 – Ignition/Electrical (Models 73542 & 73570)

Ref. No.	Part No.	Description	No. Used
1	54 755 09	Kit, 15 amp stator (Incl. 24 126 71 bracket)	1
2	M-0548025	Screw, hex. cap	2
3	24 584 01	Module, ignition	2
4	M-0545020	Screw, hex. flange	4
5	24 025 01	Flywheel	1
6	X-42-15	Key	1
7	12 468 03	Washer, plain	1
8	12 086 14	Screw, hex. flange	1
9	24 157 03	Fan	1
10	24 468 11	Washer, spring	4
11	24 112 14	Spacer, grass screen	4
12	24 144 25	Shaft, front drive	1
13	M-0839025	Screw, hex. flange	4
14	24 141 06	Ring, support	1
15	24 162 22	Screen, grass	1
16	X-25-53	Washer, plain	4
17	M-0603100	Screw, hex. cap	4
18	24 086 18	Screw, phillips hd.	1
19	X-25-92	Washer, plain	2
20	25 403 03	Rectifier-regulator 15 amp	1
21	235173	Clip, cable	1
22	X-25-63	Washer, plain	1
23	12 132 02	Spark Plug	2

Ref. No.	Part No.	Description	No. Used
24	48 154 02	Clip, cable	1
		<b>Not Illustrated</b>	
	25 518 28	Lead, black, (4" - 18 gauge - insulated grip barrel eyelet terminals)	1
	24 176 08	Harness, wiring	1
	24 176 49	Harness, wiring (Includes 3 connectors)	1
	236602	Connector	1
	15 155 01	Connector	1
	52 155 04	Connector	1
	24 126 71	Bracket, stator wire	1
	25 086 43	Screw, set (adjusts grass scraper blade)	1
	X-22-11	Washer, lock (for ground screw & wire)	1
	41 155 03	Connector	1
	277563	Connector	1
	X-67-3	Screw (mounts 5 wire connector to baffle)	2

Obtain Parts From Your Local Kohler Dealer  
Kohler Engine #CH20S-64583

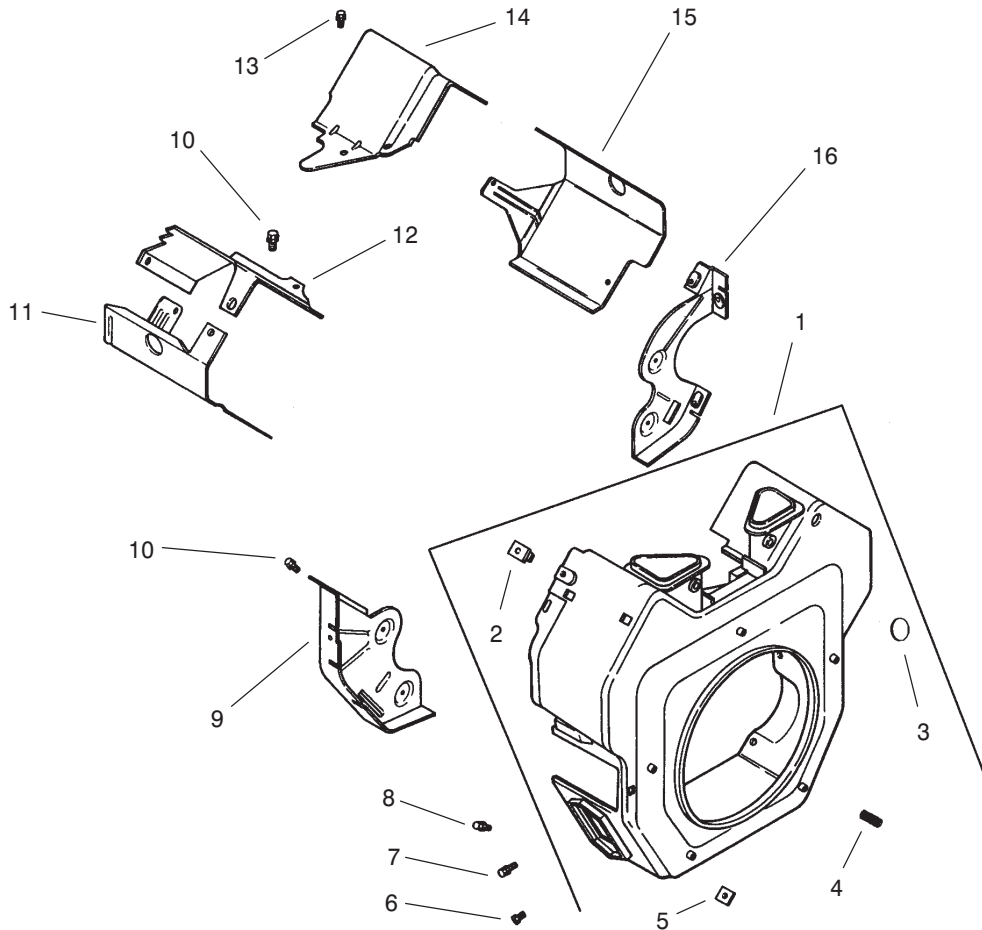

### Group 6 – Blower Housing & Baffles (Models 73542 & 73570)

Ref. No.	Part No.	Description	No. Used
1	24 027 86	Housing, blower (Includes 2-5)	1
2	24 100 02	Nut, plastic	2
3	24 755 90	Kit, button plug	1
4	24 086 43	Screw, set	1
5	24 100 01	Nut, plastic	2
6	M-0551016	Screw, hex. flange	1
7	M-0545016	Screw, hex. flange	5
8	M-0545020	Screw, hex. flange	2
9	24 146 02	Plate, backing - #2 side	1

Ref. No.	Part No.	Description	No. Used
10	M-0645016	Screw, hex. flange	6
11	24 063 20	Baffle, cyl. barrel-#2 side	1
12	24 063 17	Baffle, valley - #2 side	1
13	M-0545010	Screw, hex. flange	2
14	24 063 24	Baffle, valley - #1 side	1
15	24 063 30	Baffle, cyl. barrel-#1 side	1
16	24 146 08	Plate, backing - #1 side	1
		<b>Not Illustrated</b>	
	24 113 12	Decal, HP	1

Obtain Parts From Your Local Kohler Dealer  
Kohler Engine #CH20S-64583

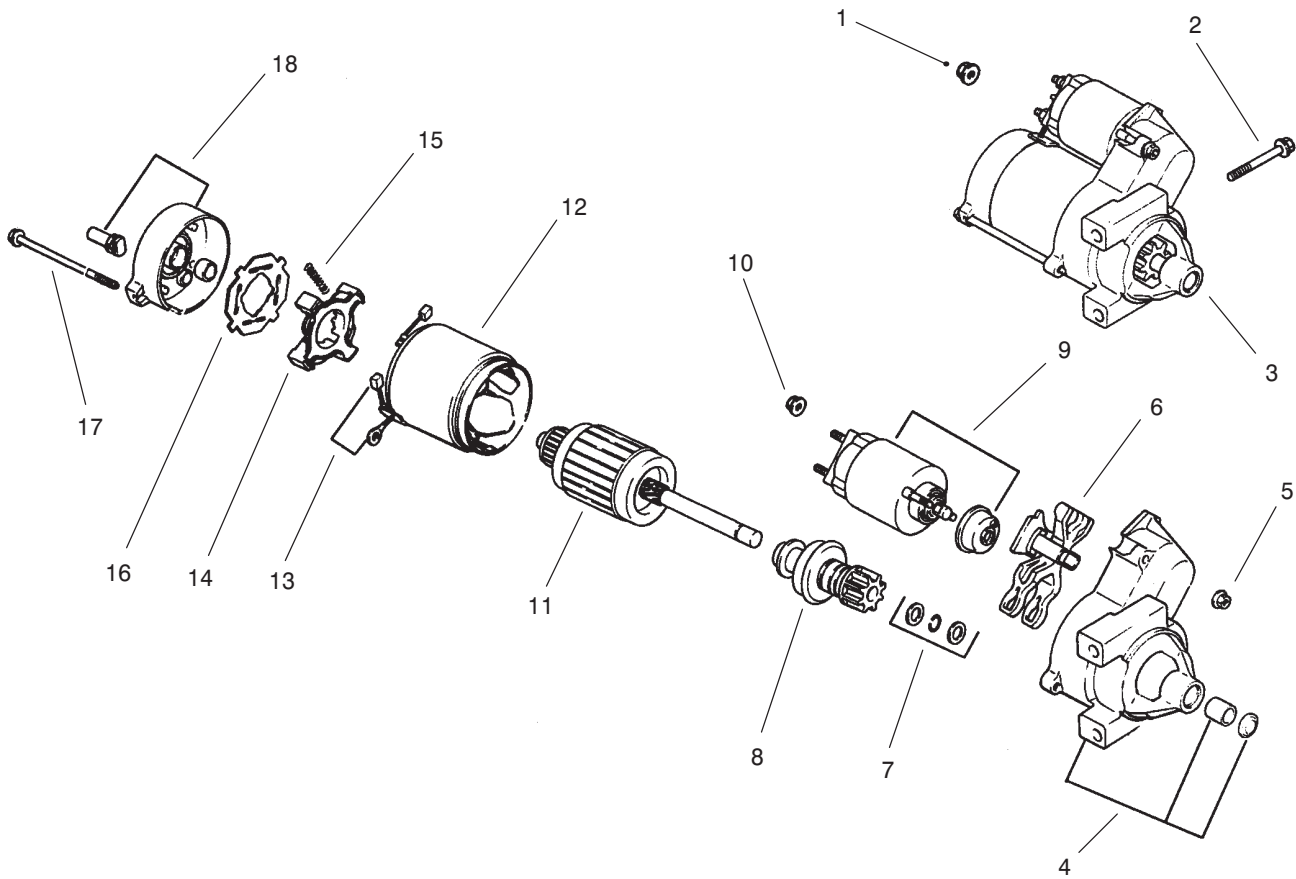

### Group 7 – Starting System (Models 73542 & 73570)

Ref. No.	Part No.	Description	No. Used
1	M-0841080	Nut, hex flange	1
2	M-0839080	Screw, hex. flange	2
3	24 098 01	Starter, solenoid shift assembly (Incl. 4-18)	1
4	24 081 04	Drive, end cap	1
5	52 100 10	Nut, starter	2
6	12 090 10	Lever, starter drive	1
7	24 755 84	Kit, starter repair	1
8	12 239 01	Drive, pinion	1
9	52 435 02	Solenoid	1

Ref. No.	Part No.	Description	No. Used
10	52 100 09	Nut, starter	1
11	12 170 04	Armature, starter	1
12	12 471 01	Frame	1
13	52 221 01	Kit, brush & spring (Includes 15)	1
14	52 323 03	Holder, brush	1
15	52 089 09	Spring, brush	4
16	52 168 01	Insulator	1
17	52 211 05	Bolt, thru	2
18	24 301 01	Commutator, end cap	1

**Obtain Parts From Your Local Kohler Dealer**  
 Kohler Engine #CH20S-64583

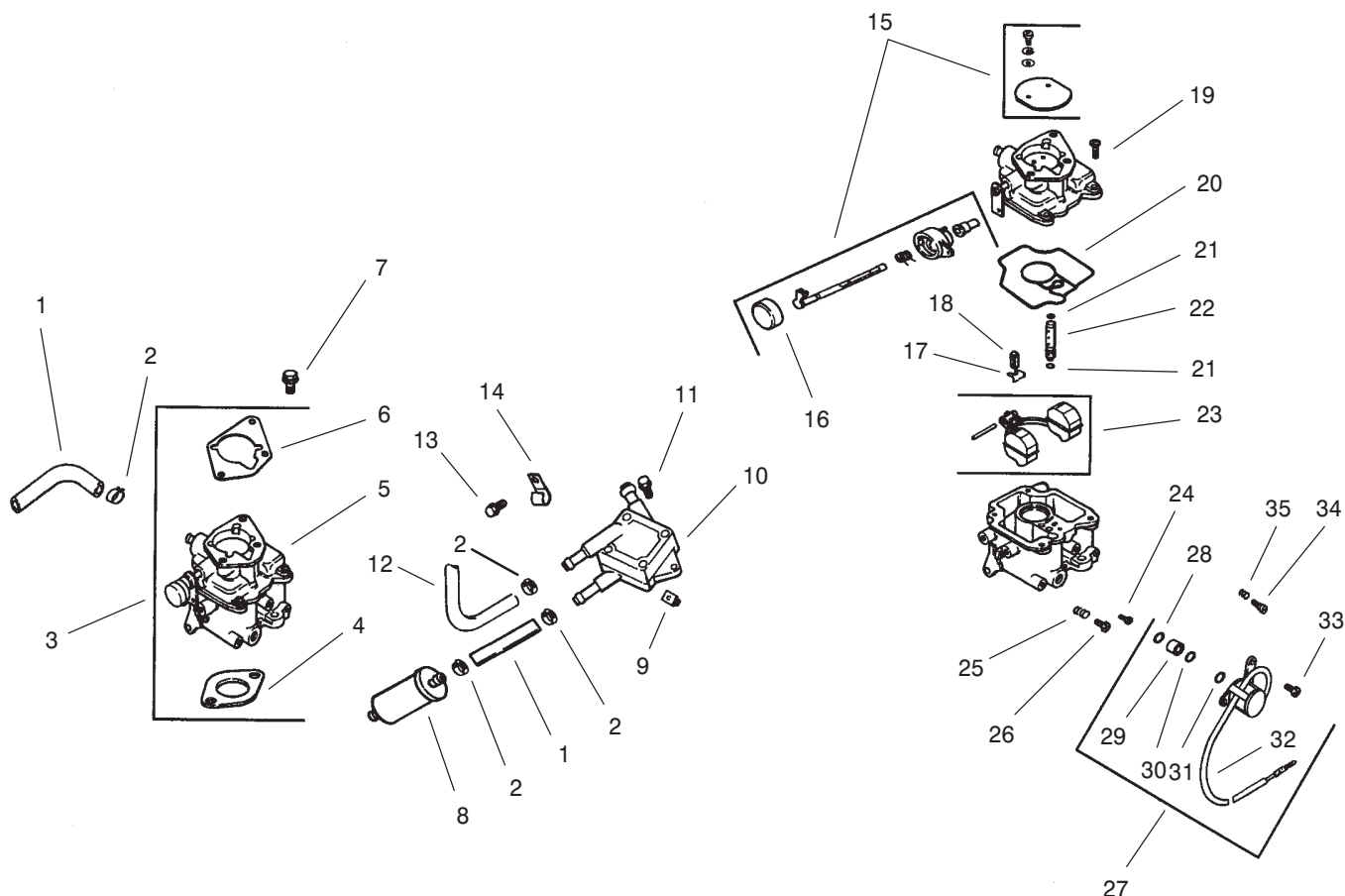

## Group 8 – Fuel System (Models 73542 & 73570)

Ref. No.	Part No.	Description	No. Used	Ref. No.	Part No.	Description	No. Used
1	25 353 10	Line, fuel 9"	2	19	24 086 09	Screw, carburetor body	4
2	X-426-9	Clamp, hose	6	20	24 041 09	Gasket, carburetor body	1
3	24 853 32	Kit, carburetor w/gasket (Includes 4-6)	1	21	24 153 02	O-Ring, slow jet	2
4	24 041 06	Gasket, air cleaner base	1	22	24 337 01	Jet, slow	1
5	24 053 32	Carburetor assembly (Includes 15-35)	1	23	24 757 02	Kit, float repair	1
6	24 041 17	Gasket, carburetor	1	24	24 337 02	Jet, main	1
7	M-0651030	Screw, hex. flange	2	25	24 089 10	Spring, idle adjust screw	1
8	24 050 02	Filter, fuel	1	26	24 086 10	Screw, idle adjusting	1
9	24 100 01	Nut, plastic	2	27	24 757 01	Kit, solenoid (Includes 28-33)	1
10	24 393 04	Pump, fuel – pulse	1	28	24 153 06	O-Ring	1
11	24 086 12	Screw, hex. cap	2	29	24 521 01	Seat, solenoid	1
12	24 353 04	Line, fuel 17"	1	30	24 153 05	O-Ring	1
13	M-0650012	Screw, hex. flange	1	31	24 153 04	O-Ring	1
14	47 154 01	Clip, cable	1	32	24 435 01	Solenoid	1
15	24 757 07	Kit, choke repair (Includes 16)	1	33	24 086 07	Screw, solenoid	2
16	24 173 02	Cap, choke lever	1	34	24 368 01	Needle, idle	1
17	24 154 01	Clip, inlet needle valve	1	35	24 089 11	Spring, idle needle	1
18	24 462 01	Valve, inlet needle	1			<b>Not Illustrated</b>	
					24 757 03	Kit, carburetor repair	1

Obtain Parts From Your Local Kohler Dealer  
Kohler Engine #CH20S-64583

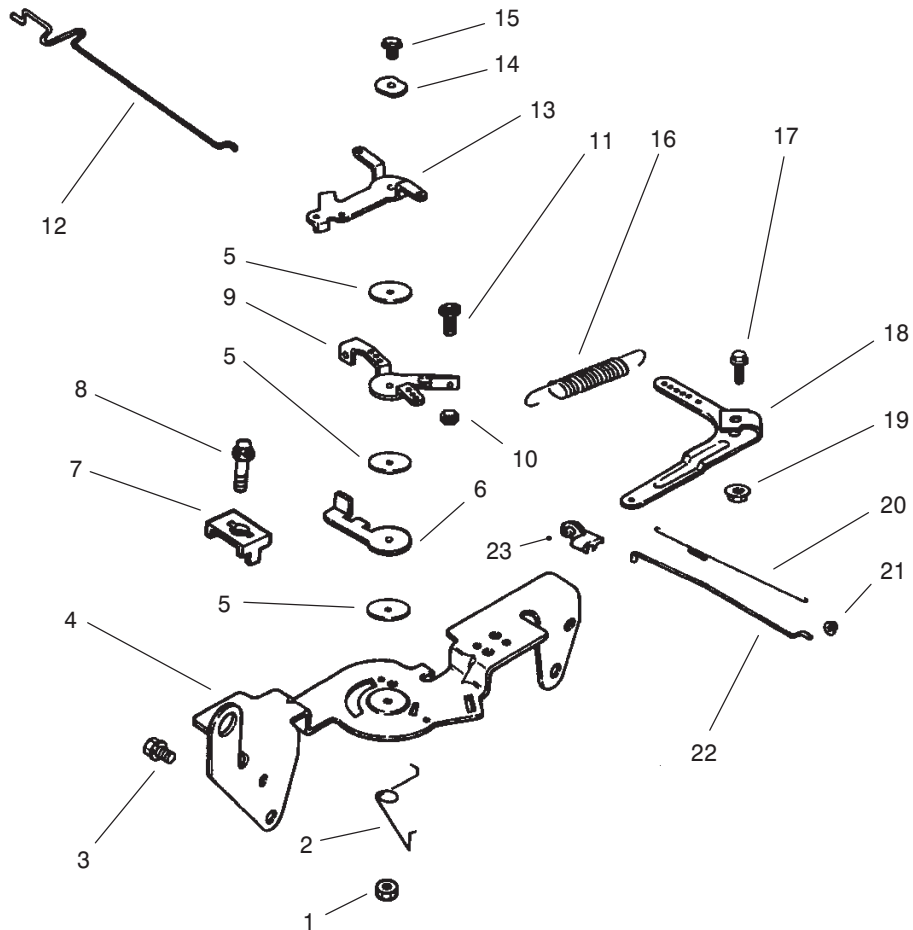

## Group 9 – Engine Controls (Models 73542 & 73570)

Ref. No.	Part No.	Description	No. Used
1	M-0547050	Nut, hex. lock	1
2	24 089 03	Spring, choke return	1
3	M-0645016	Screw, hex. flange	4
4	24 126 56	Bracket, control	3
6	24 090 07	Lever, throttle actuator	1
7	12 237 01	Clamp, cable	2
8	M-0545016	Screw, hex. flange (On: 73540 Only)	2
8	98-7374	Screw, torx (On: 73541 Only)	2
9	24 090 03	Lever, throttle control	1
10	M-0446030	Nut, hex	1
11	M-0401030	Screw, hex. cap	1
12	24 079 02	Linkage, choke	1

Ref. No.	Part No.	Description	No. Used
13	24 090 05	Lever, choke	1
14	41 468 03	Washer, spring	1
15	M-0545020	Screw, hex. flange	1
16	24 089 15	Spring, governor	1
17	SM-0642025	Screw, hex. flange	1
18	24 090 14	Lever, governor	1
19	M-0641060	Nut, hex. flange	1
20	24 089 01	Spring, linkage	1
21	25 158 08	Bushing, linkage retaining	1
22	24 079 01	Linkage, throttle	1
23	25 158 11	Bushing, linkage retaining	1

Obtain Parts From Your Local Kohler Dealer  
Kohler Engine #CH20S-64583

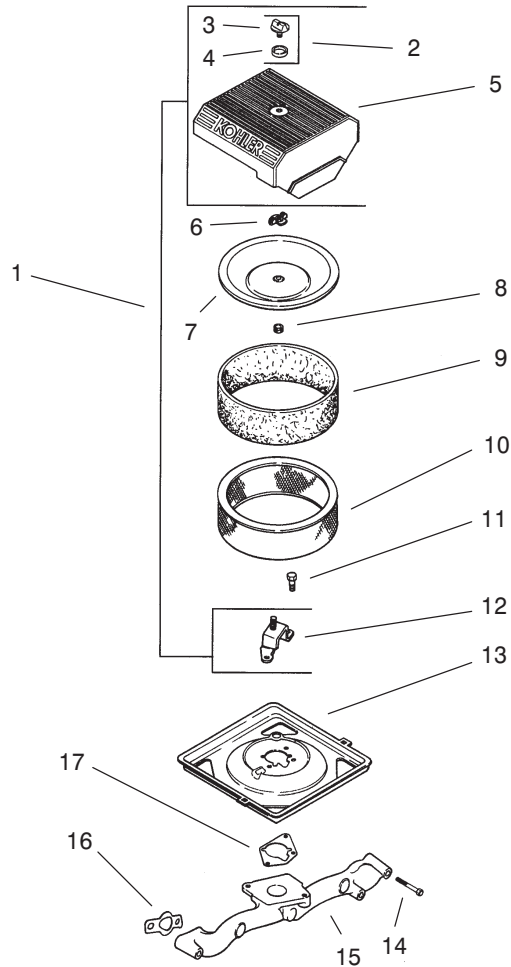

### Group 10 – Air Intake (Models 73542 & 73570)

Ref. No.	Part No.	Description	No. Used	Ref. No.	Part No.	Description	No. Used
1	24 743 05	Kit, air cleaner cover (Includes 2-5, 12)	1	8	24 032 03	Seal, inner air cleaner	1
2	54 755 01	Kit, knob with sea (Includes 3,4)	1	9	24 083 02	Precleaner, element	1
3	25 341 03	Knob, cover	1	10	47 083 03	Element, air cleaner	1
4	24 153 15	Seal, air cleaner cover knob	1	11	M-0639016	Screw, hex. flange	3
5	24 096 24	Cover, air cleaner	1	12	24 126 21	Bracket, air cleaner base	1
6	12 100 01	Wing Nut	1	13	24 094 03	Base, air cleaner	1
7	24 096 01	Cover, inner air cleaner	1	14	M-0651055	Screw, hex. flange	4
				15	24 164 14	Manifold, intake	1
				16	24 041 01	Gasket, intake manifold	2
				17	24 041 06	Gasket, air cleaner base	1

**Obtain Parts From Your Local Kohler Dealer**  
 Kohler Engine #CH20S-64583

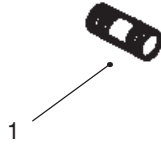

### Group 11 – Exhaust (Models 73542 & 73570)

Ref. No.	Part No.	Description	No. Used
1	25 072 04	Stud	4
	24 782 01	<b>Not Illustrated</b> Miniblock	
	24 755 03	Gasket Set	

Ref. No.	Part No.	Description	No. Used

Obtain Parts From Your Local Kohler Dealer  
 Kohler Engine #CH20S-64583







