



MODEL NO. 09700TE—200000001 &amp; UP

OPERATOR'S  
MANUAL**PROCORE 440 AERATOR**

To understand this product, and for safety and optimum performance, read this manual before starting operation. Pay special attention to **SAFETY INSTRUCTIONS** highlighted by this symbol.



# Table of Contents

<b>Table of Contents</b>	<b>2</b>	<b>Controls</b>	<b>17</b>
<b>Safety</b>	<b>3</b>	<b>Operation</b>	<b>18</b>
<b>Symbol Glossary</b>	<b>6</b>	Adjust Tine Depth	18
<b>Specifications</b>	<b>8</b>	Principles Of Operating	21
Set-Up Instructions	9	Training Period	21
Tractor Requirements	9	Before Aerating	22
Ballast Requirements	9	Aerating Procedures	22
Connect Lower Link Arms	9	Transport Operation	22
Connect The Upper Link	9	Inspection And Clean-Up After Use	23
Install Side Guards	10	Operating Tips	23
Adjust the PTO Shaft Length	10	<b>Maintenance</b>	<b>24</b>
Connect the PTO Shaft	11	Greasing Bearings And Bushings	24
Mount the Castor/Safety Stand	11	Gearbox Lubrication	24
Adjusting The Sway Links	12	Torque Set Screws	25
Level the Aerator Side-To-Side	13	Adjusting Pulley Scrapers	25
Adjust the 3-Point Lift Stop	13	Adjusting Belt Tension	25
Install Tines/Tine Heads	13	Replacing Belts	26
Mount The Turf Guards	13	Storage	27
Adjust The Roller Scraper	14	<b>Identification And Ordering</b>	<b>28</b>
Adjust The Turf Guards	14		
Removing the Aerator from the Tractor	15		

# Safety

Improper use or maintenance of the machine can result in injury. To reduce the potential for injury, comply with the following safety instructions.

## Before Operating

1. Owners of this aerator must give operators and employees full operation and safety instructions before allowing them to operate this machine and at least annually thereafter. An operator who has not read and fully understood all operating and safety instructions is not qualified to operate this machine. Become familiar with all controls and know how to stop quickly.
2. Do not allow children to operate the machine. Do not allow adults to operate the machine without proper instruction.
3. Remove all debris or other objects that might interfere with operation. Keep all bystanders away from the work area.
4. Locate and mark all underground obstructions such as irrigation components, electrical or telephone lines.
5. Make sure the tractor is in neutral and the hand brake is applied before starting. Refer to your tractor operator's manual for safe starting procedures.
6. To maintain full steering control, add front-end weights to the tractor. Refer to the tractor operator's manual for weight requirements.
7. Keep all shields and safety devices in place. If a shield, safety device or decal is damaged, repair or replace it before beginning operation. Also tighten any loose nuts, bolts and screws to assure the machine is in safe operating condition.
8. Do not operate the machine while wearing sandals, tennis shoes, sneakers or shorts. Also, do not wear loose fitting clothing that could get

caught in moving parts. Always wear long pants and substantial shoes. Wearing safety glasses, safety shoes, ear protection and a helmet is advisable and may be required by some local ordinances and insurance regulations.

## While Operating

9. Keep all bystanders and pets away from the work area.
10. Using the machine demands attention, and to prevent loss of control:
  - A. Use only in daylight or when there is good artificial light.
  - B. Watch for holes or other hidden hazards.
  - C. Do not transport the machine close to a sand trap, ditch, creek or other hazard.
  - D. Reduce speed on side hills and before making sharp turns to prevent tipping or loss of control.
  - E. Look behind the aerator before backing up.
11. If the tines strike a solid object or the machine vibrates abnormally, shut the engine off. Remove the key from the ignition switch. Check the aerator and traction unit for damage. Repair any damage before restarting the engine and operating the tines. Be sure tines are in good condition and all bolts are tight.
12. Before leaving the machine unattended, disengage power to the aerator, lower the aerator and set the parking brake. Stop the engine.
13. Never dismount while the tractor is in motion. Never get on or off the tractor while the engine is running and the PTO drive shaft is engaged. Never step over the PTO shaft to reach other side of the aerator—walk around the machine.
14. Park the aerator on a level surface, install the rear

support/safety stand and chock roller before disconnecting from the tractor.

15. If it is necessary to probe below the soil surface, use a non conductive material to prevent electrical shock in case electrical wires are present.

### Transporting

16. Be sure you are in compliance with all regulations regarding transporting equipment on the public roads and highways.
17. Ensure that all reflectors and lights required are in place and are clean and visible to overtaking and oncoming traffic.
18. Never allow anyone to ride on the machine during transport.
19. Reduce speed on rough roads and surfaces.
20. Independent brakes should ALWAYS be locked together when on the road.

### PTO Shaft

21. For all PTO shaft steel parts (tubes, bearings, joints, etc.) disassembly or repairs, it is highly advisable to contact your local Toro distributor. Removal of components for repairs and re-assembly may damage some parts if not carried out correctly using special tools available in a dealer's workshop.
22. The PTO shaft should not be used without the guards supplied, with partial protection, with damaged guard or without the special anti-rotation chains correctly hooked, so as to permit the maximum angle of the PTO shaft without breaking the chains.

### Storage Safety

23. Store the aerator on a firm level surface.

24. Store the aerator away from areas of human activity.
25. DO NOT allow children to play on or around the stored machine.
26. Make sure the aerator is sifting, or blocked up firm and solid and will not sink into soft ground causing it to tip.
27. Ensure that the rear stand pin is secured in place.
28. Block the aerator to prevent it from rolling or tipping.

### Maintenance

29. Before making adjustments or performing maintenance on the aerator, switch off the engine, stop the PTO and apply the hand brake before dismounting from the tractor. Be sure the aerator is on the ground or lowered onto the rear castor/safety stand.
30. Support the machine with the rear castor/safety stand when working beneath it. NEVER rely on the tractor's hydraulics to support the machine.
31. Place all controls in neutral, stop the engine, apply the hand brake and wait for all moving parts to stop before servicing maintaining, adjusting or unblocking the aerator.
32. Be sure the machine is in safe operating condition by keeping nuts, bolts and screws tight. Check the tine mounting bolts and nuts frequently to be sure they are tightened to specification.
33. DO NOT check or adjust belt tension when the tractor engine is running.
34. Be sure all guards are replaced and the hood is securely shut after maintaining or adjusting the machine.
35. Perform only those maintenance instructions described in this manual. If major repairs are

ever needed or assistance is desired, contact an Authorized Toro Distributor. To ensure optimum performance and safety, always purchase genuine TORO replacement parts and accessories to keep the Toro all TORO. NEVER USE “WILL-FIT” REPLACEMENT PARTS AND ACCESSORIES MADE BY Other MANUFACTURERS. Look for the TORO logo to assure genuineness. Using unapproved replacement parts and accessories could void the warranty of The Toro Company.

# Symbol Glossary

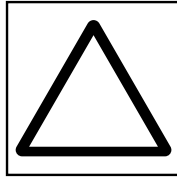

**SAFETY ALERT SYMBOL**



**GENERAL HAZARD SAFETY ALERT**



**CRUSHING OF WHOLE BODY, APPLIED FROM ABOVE**

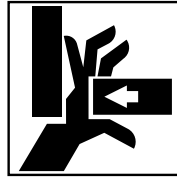

**CRUSHING OF FINGERS OR HAND, FORCE APPLIED FROM SIDE**

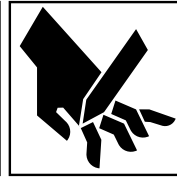

**CUTTING OF FINGERS OR HAND**

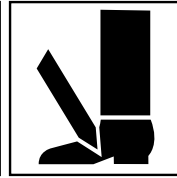

**CUTTING OF FOOT**



**CRUSHING OR PUNCTURE OF FOOT, CORING HEAD**



**WHOLE BODY ENTANGLEMENT, IMPLEMENT INPUT DRIVE LINE**

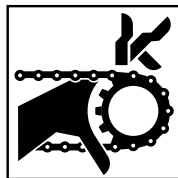

**FINGERS OR HAND ENTANGLEMENT, CHAIN DRIVE**



**THROWN OR FLYING OBJECTS, WHOLE BODY EXPOSURE**

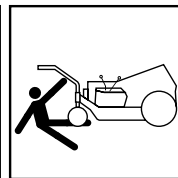

**RUNOVER/BACKOVER, GREENS AERATOR**

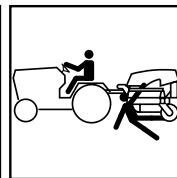

**RUNOVER/BACKOVER, HC 4000 AERATOR**



**SECURE LIFTING CYLINDER WITH LOCKING DEVICE BEFORE GETTING IN HAZARDOUS AREA**



**INSERT SAFETY LOCK BEFORE GETTING IN HAZARDOUS AREA**

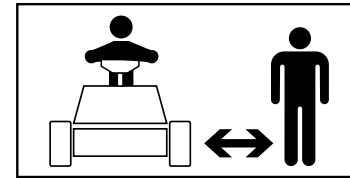

**STAY A SAFE DISTANCE FROM MACHINE, GREENS AERATOR**

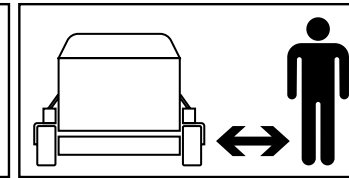

**STAY A SAFE DISTANCE FROM MACHINE, HC 4000 AERATOR**

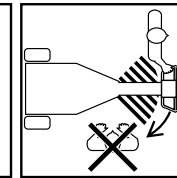

**STAY CLEAR OF ARTICULATION AREA WHILE ENGINE IS RUNNING, GREENS AERATOR**

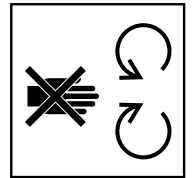

**DO NOT OPEN OR REMOVE SAFETY SHIELDS WHILE ENGINE IS RUNNING**

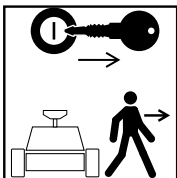

**SHUT OFF ENGINE & REMOVE KEY BEFORE LEAVING OPERATOR POSITION, GREENS AERATOR**

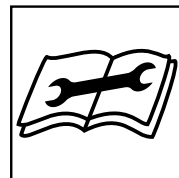

**CONSULT TECHNICAL MANUAL FOR PROPER SERVICE PROCEDURES**

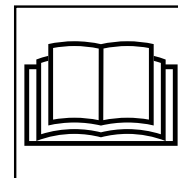

**READ OPERATOR'S MANUAL**

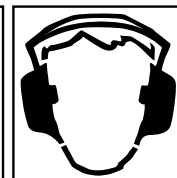

**HEARING PROTECTION MUST BE WORN**

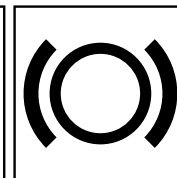

**BRAKE SYSTEM**

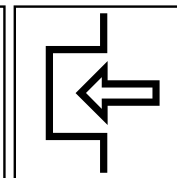

**ENGAGE**

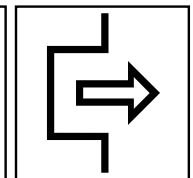

**DISENGAGE**

Symbol Glossary

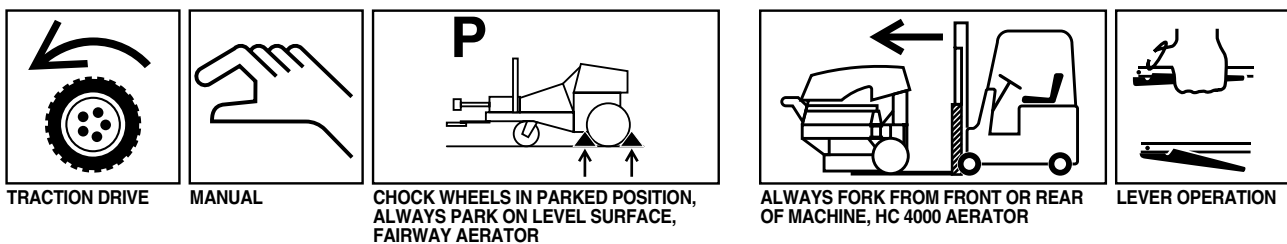
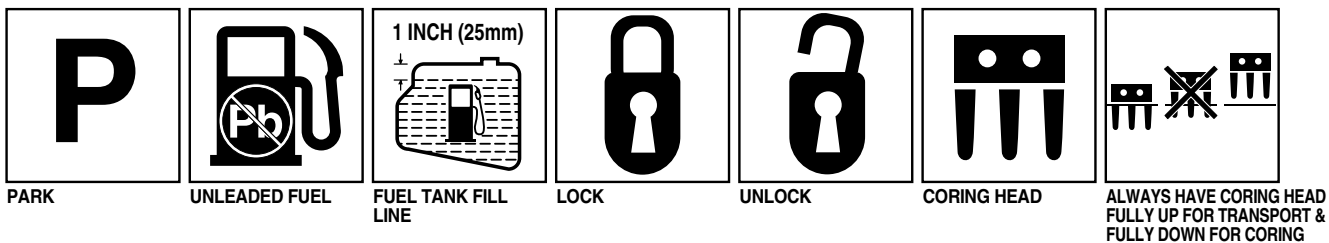
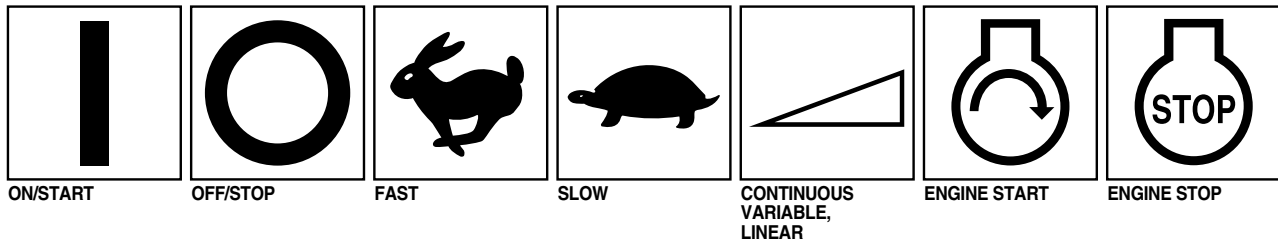

# Specifications

Working Width—40” (1.0 m)  
 Overall Width—52” (1.32 m)  
 Overall Length—33” (0.84 m)  
 Overall Height—34” (0.86 m)  
 Number of Tine Heads—6  
 Roller Diameter—6 inches (152 mm)  
 Weight—840 lbs. (381 Kg)

PTO Speed—540 rpm  
 Power Requirement—16 hp (12 KW)  
 Hitch Category—Category one, three-point linkage  
 Min./Max. Depth—0–4.2” (0–105 mm)  
 Drive Belt Section—HA (2)/tine pair

km/hr	Forward Hole Spacings	Lateral Hole Spacing Mini Tine	Lateral Hole Spacing 4-Tine Head	Lateral Hole Spacing 3-Tine Head	Sq. m/hr
1.0	25mm	30mm	62mm	81mm	936
1.3	38mm	30mm	62mm	81mm	1,252
1.7	51mm	30mm	62mm	81mm	1,906
2.3	64mm	30mm	62mm	81mm	2,386
2.7	76mm	30mm	62mm	81mm	2,850
3.2	89mm	30mm	62mm	81mm	3,330
3.5	102mm	30mm	62mm	81mm	3,794
4.0	114mm	30mm	62mm	81mm	4,292

**Note:** Performance specifications shown are maximum values obtained at rated (540 rpm) PTO speed. Changing engine / PTO rpm in any particular gear (or fixed hydrostatic pedal position) will NOT change forward hole spacings, although mph and productivity specifications WILL be proportionately changed

# Set-Up Instructions

## Tractor Requirements

- 16 KW
- Correct tire pressure
- Category one 3-point hitch, rated to lift at least a 1000 lb. (454 Kg) implement
- 540 rpm tractor PTO
- Adequate front end weight (ballast)

## Ballast Requirements

!CAUTION!

To help prevent bodily injury and provide added stability, make sure the front of the tractor is equipped with proper ballast. Refer to the tractor operator's manual for ballast requirements.

Refer to the tractor operator's manual for ballast requirements.

## Connect Lower Link Arms

1. The aerator must be positioned on a flat, level surface for installation.
2. Back the tractor squarely up to the aerator until the lower link arms are aligned with the hitch pins.
3. Make sure the PTO is disengaged.
4. Engage the parking brake, STOP the engine and remove the key from the ignition. Wait for the engine and all moving parts to STOP before leaving the operator's seat on the tractor.
5. Insert the right and left lower link arms onto the hitch pins (Fig. 1).

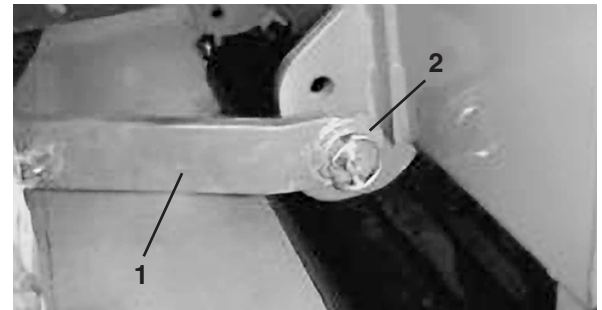

Figure 1

1. Lower link
2. Lynch pin

6. Secure the lower link arms to the hitch pins with lynch pins (Fig. 1)

## Connect The Upper Link

**NOTE:** The front of the aerator **MUST** be vertical or angle forward slightly while operating for best aeration hole quality (Fig. 2). This angle will change when depth adjustments are made. Adjust the upper link to control this angle. Refer to *Operation* for additional information.

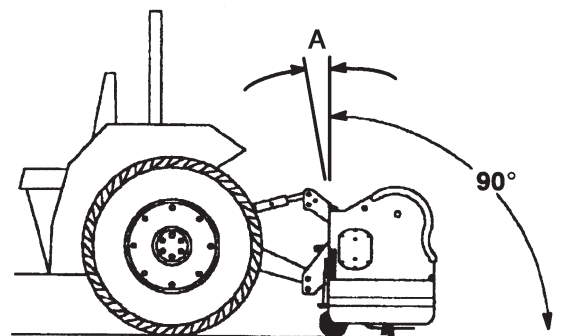

Figure 2

1. 0–8° Operating range

1. Connect the upper link (Fig. 3) to the bracket and secure with a link pin and lynch pin.

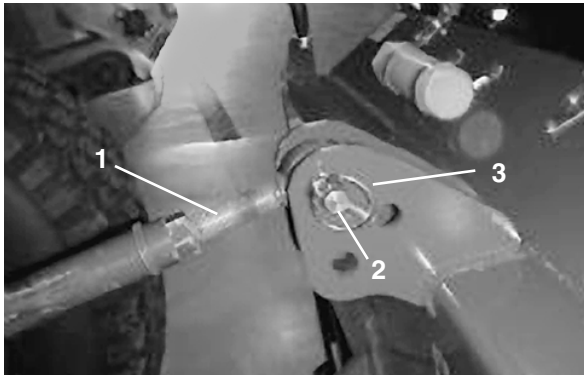

Figure 3

- 1. Upper link
- 2. Link pin
- 3. Lynch pin

2. Rotate the adjusting link to tighten the link. Do not overtighten to raise the back end of the aerator off the ground.
3. Tighten the lock nut to secure the upper link into position.

## Install Side Guards

1. Remove the (4) nuts, lock washers and washers loosely secured to each bottom end of the aerator frame.
2. Position the appropriate side guard (left or right) onto the mounting studs (Fig. 4).
3. Secure each side guard to the mounting studs with the washers and nuts previously removed.

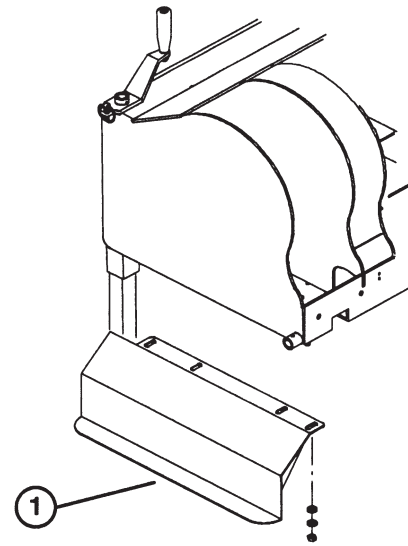

Figure 4

- 1. Side guard (L.H.)

## Adjust the PTO Shaft Length

**IMPORTANT:** A long PTO shaft is supplied with the machine to accommodate large variations in the tractor's PTO and 3-point locations. For some tractors, this shaft is too long and must be cut to the correct length or gearbox damage may result.

1. With the aerator vertical or angled slightly forward, lower the aerator until the gear box shaft is approximately the same height as the tractor PTO shaft. This is the shortest distance between the two shafts.
2. Measure the distance from the lock groove of the tractor PTO shaft to the lock groove of the aerator gearbox PTO shaft. Record this dimension.
3. Fully collapse the PTO shaft and measure the distance between the lock pin collars. Record this dimension.
4. At its shortest length, the two halves of the PTO shaft must have at least 1.5 inches (37 mm) of additional clearance to collapse. If the dimension in step 2 is not at least 1.5 inches (37 mm) greater than the dimension in step 3, the PTO shaft is too long; go to step 5. If there is enough

clearance to allow the PTO shaft to collapse, go to step 10.

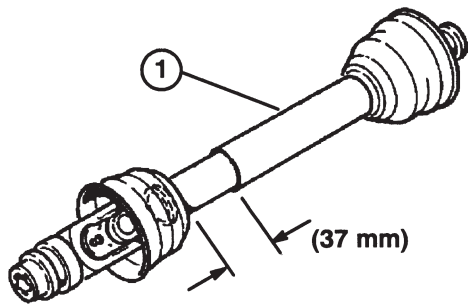

Figure 5

1. PTO shaft

5. Use the following calculation to establish how much shorter the shaft must be, when connected, to assure a clearance of 1.5 inches (37 mm).
  - A. Subtract the dimension recorded in step 3 from the dimension recorded in step 2. Record this dimension.
  - B. Subtract the result in step 5A from 1.5" (37mm). The PTO shaft must be shortened by this amount.
6. Using a hacksaw, cut the yellow guards and the steel tubes shorter by the calculated length. Cut both halves of the PTO shaft
7. Deburr the ends of the steel tubes internally and externally.
8. Remove all debris from the tube sections.
9. Grease the steel tubes liberally
10. Assemble the PTO shaft and secure it to the aerator and tractor.
11. Measure the shaft. If not at least 1.5 inches (37 mm), repeat the procedure.
12. Raise the the aerator to its highest position. There must be at least 3 inches (75 mm) of overlap of the halves. Adjust the 3-point lift stop, if necessary. Refer to *Adjust the 3-point Lift Stop*.

## Connect the PTO Shaft

1. Connect the PTO shaft to the gearbox input shaft.
2. Connect the PTO shaft to the rear tractor PTO shaft.
3. Slide the PTO shaft forward as far as it will go.
4. Depress the pin to secure the PTO shaft in place. Slide the PTO shaft back and forth to make sure it is properly locked.

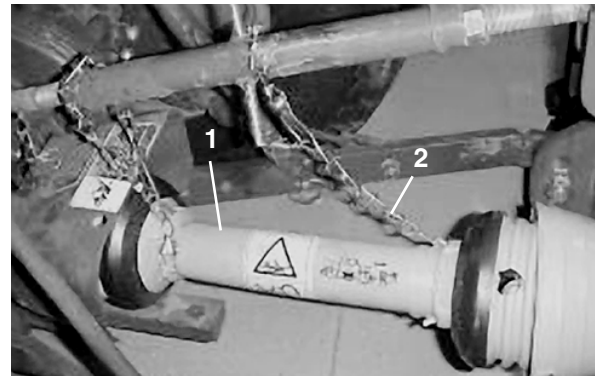

Figure 6

1. PTO shaft  
2. Safety chains

5. Connect the shield safety chains from the power shaft sections to the welded clips on the link arms or to the PTO shields. Make sure the chains remain slack when the aerator is raised or lowered.

	<b>CAUTION</b>	
<p>To help prevent bodily injury, keep all PTO shields in place and connect the shield chains to the link arms or PTO shields to prevent the shields from rotating during operation.</p>		

## Mount the Castor/Safety Stand

**NOTE:** Use the castor wheel to move the aerator around on a hard surface, when aligning to the tractor for installation or for storage. Level the aerator by adjusting the roller until the point of the depth adjustment arrow is just above the side guards.

1. Remove the bolt and nut securing the rear castor/safety stand tube to the shipping pallet. Retain the bolt and washer for installation of the castor wheel.

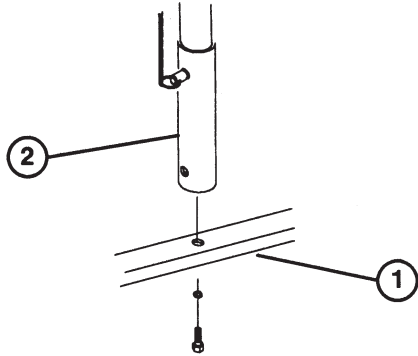

Figure 7

1. Shipping pallet
2. Castor/safety stand

2. Raise the aerator off the pallet.
3. Remove the pallet.
4. Mount the castor wheel to the rear castor/safety stand tube with the previously-removed bolt and washer (Fig. 8).

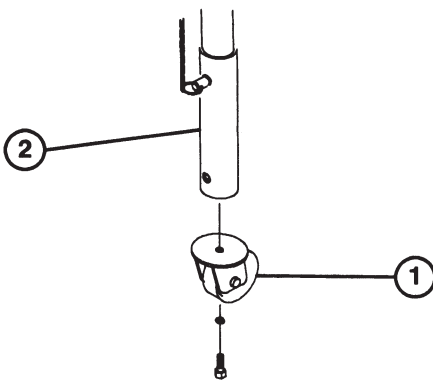

Figure 8

1. Castor wheel
2. Castor/ safety stand

5. The rear castor/safety stand has two positions:
  - Collapsed for aerator storage
  - Extended for aerator maintenance
6. Secure the castor/safety stand in desired position with the pin. Tighten the castor knob.
7. Slowly lower the aerator to the ground.

**NOTE:** To store the castor/safety stand when not in use:

- A. Remove the wheel, collapse the tubes and secure with it with the pin. Store components between the aerator main center plates under the hood. Tighten the castor knob.

or

- B. Complete assembly can be secured upside down in receiver bracket. Tighten the castor knob.



Figure 9

1. Pin
2. Castor knob

## Adjusting The Sway Links

Adjust the sway links on the lower draft arms of the 3-point hitch to keep side-to-side sway to a maximum of less than 1 inch (25 mm) on each side.

1. Adjust the lower links until they contact the aerator mounting plates. This will reduce the stress on the pins. If the tractor has sway chains instead of sway links, washers should be installed between the lower link arm and the lynch pin to reduce the load on the lift pins.

**NOTE:** Refer to the tractor operator's manual for additional installation and adjustment procedures.

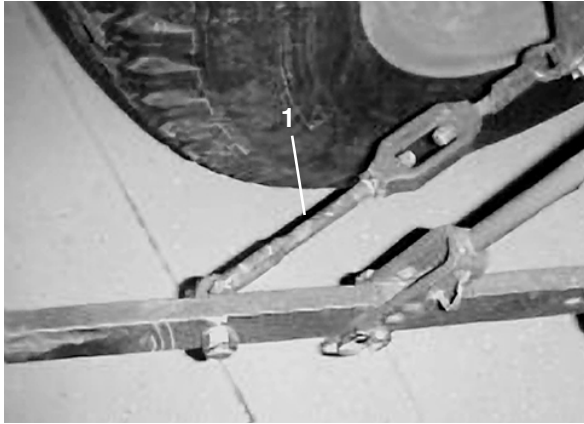

Figure 10

1. Sway link

## Level the Aerator Side-To-Side

1. Park the tractor and aerator on a level, firm surface.
2. Place a level on top of the aerator hood to check for level side-to-side.

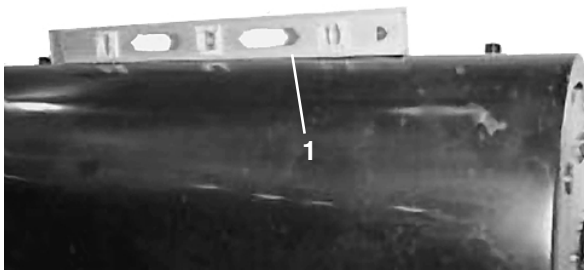

Figure 11

1. Level

3. Turn the adjustable link body (if provided) to raise or lower the link arm until the aerator is leveled side-to-side.

**NOTE:** Refer to the tractor operator's manual for additional adjustment procedures.

## Adjust the 3-Point Lift Stop

Adjust and set the 3-point lift stop (Fig. 12) to provide approximately 10cm (4") ground clearance, when in the raised position, to minimize PTO angle when raising the aerator. For transporting or trailer loading/unloading, the full lift range can be used as long as the PTO tubes do not slide apart. Operating the PTO in the fully raised position may damage the PTO.

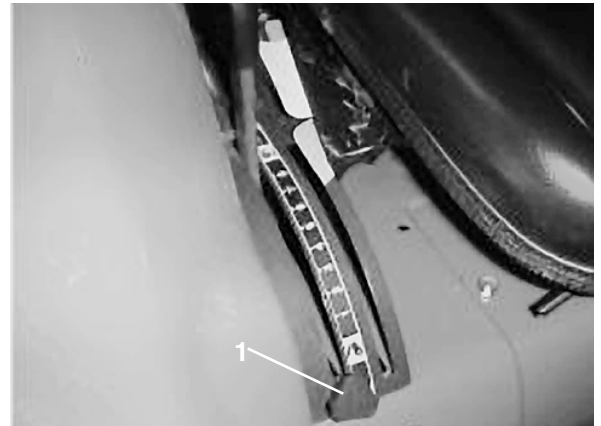

Figure 12

1. 3-point lift stop

**NOTE:** Refer to the tractor operator's manual for adjustment procedures.

## Install Tines/Tine Heads

A wide selection of tines and tine heads are available for the aerator. Choose the tine type, size and spacings required for the job. Install the tine head and tines per Installation Instructions supplied with each tine kit. Refer to accessory chart for required tines.

**IMPORTANT: Never operate the aerator without the tine heads installed. The arms will move excessively and may damage the aerator frame.**

## Mount The Turf Guards

A wide selection of turf guards are available for the aerator. Choose the required turf guards per accessory chart.

1. Loosen the nuts securing the turf guard clamps to

the turf finger tool bar (Fig. 13).

2. Slide the appropriate turf guard under the center turf guard clamp while inserting the notch onto the locator key of the turf finger bracket (Fig. 13).

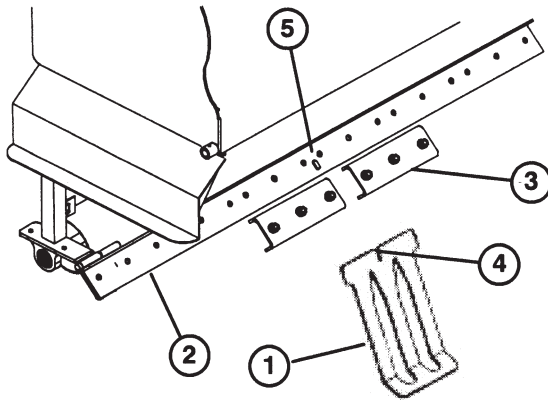

**Figure 13**

1. Turf guard
2. Turf finger tool bar
3. Turf guard clamp
4. Notch
5. Locator key

3. Tighten the nuts securing the turf guard and the center turf guard clamp to the turf finger bracket.

4. Working outward, mount the remaining turf guards to each side and secure the turf guard clamps.

**IMPORTANT: From the rear of the machine, check that the tines line up with the center of the gaps in the turf guards.**

5. To decrease down pressure of turf guards:
  - A. Remove the nuts securing each end of the turf finger bracket to the roller legs (Fig. 14).
  - B. Pivot the turf finger bracket upward and insert a washer onto each stud.
  - C. Pivot the turf finger downward onto the studs and check the angle.
  - D. Install nuts to secure the assembly.

**NOTE:** Aeration depth may need to be reduced to assure clearance between the tine heads and the turf guards. Check clearance before aerating.

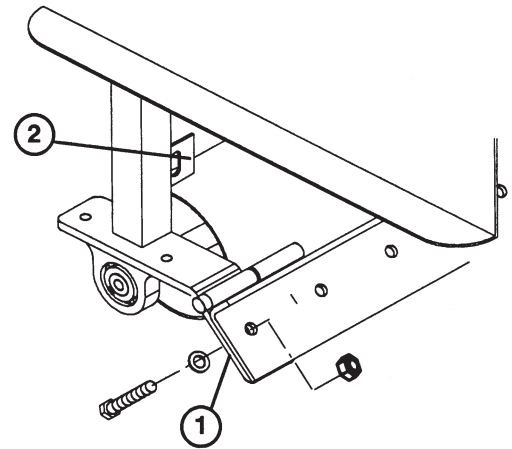

**Figure 14**

1. Spacer location (11 each end)
2. Roller scraper tab

**NOTE:** To aid in the loading/unloading the aerator from a trailer, remove the nuts securing each end of the turf finger tool bar to the roller legs and pivot the turf finger tool bar upward.

## Adjust The Roller Scraper

Adjust the roller scraper so there is approximately a 1/8" (3mm) gap between the scraper and the roller.

1. Loosen the fasteners securing each end of the scraper to the roller scraper tab (Fig. 14).
2. Slide the roller scraper up or down to the required position and tighten the fasteners.

## Adjust The Turf Guards

Before starting your new aerator, remove the rear castor stand and lower the machine on the 3-point linkage until the depth control roller is resting on the ground. From the rear of the machine, check that the tines line up exactly with the center of the gaps in the turf guards. Install the correct turf guards (Fig. 15), if necessary.



Figure 15

**NOTE:** Turf with a good root structure may not require the turf guards. If this is the case, **DO NOT REMOVE** the TURF GUARD TOOL BAR because this adds support to the roller leg assembly. Just remove the plastic fingers from the turf guard bracket.

## Removing the Aerator from the Tractor

1. Stop the vehicle on a level surface, not on a slope.
2. Disengage the PTO and engage the parking brake.
3. STOP the engine and remove the key from the ignition switch.
4. Before leaving the operator's seat on the tractor, wait for the engine and all moving parts to STOP.
5. Install the rear castor/safety stand, collapse it to storage position and install the pin. Tighten the knob.
 

**NOTE:** The aerator can be stored on the original shipping pallet if desired. Remove the castor wheel.
6. Disconnect the safety shield chains from the PTO. Secure the end of the chain to the aerator side of the PTO shaft to prevent the PTO shaft from coming apart.
7. Slowly lower the aerator until the rear castor/safety stand contacts the ground.
8. Lower the roller, by adjusting the depth control handles, until the roller contacts the ground.
9. Loosen the locking nut and rotate the adjusting link to release tension between the aerator and tractor.
10. Remove the lynch pin and top link pin securing the center link to the bracket.
11. Push the release pin to disconnect the power shaft from the tractor's PTO shaft.
12. Slide the power shaft back and remove it from the tractor.
13. Remove the lynch pins and slide the lower link arms off the hitch pins.

# Accessory Chart

## ProCore 440 Aerator

### Model Number 09700 TE

8 Mini Tine Head	3-Tine Heavy-Duty Head	4-Tine Heavy-Duty Head	3-Tine Head	4-Tine Head
<b>Heads Required</b> <hr/> 4 Model 09721	<b>Heads Required</b> <hr/> 6 Model 09733	<b>Heads Required</b> <hr/> 4 Model 09734	<b>Heads Required</b> <hr/> 4 Model 09722	<b>Heads Required</b> <hr/> 4 Model 09723
<b>Turf Guards Required</b> <hr/> 2 x #100-5420* 3 x #100-5421	<b>Turf Guards Required</b> <hr/> 2 x #100-5414 1 x #100-5415*	<b>Turf Guards Required</b> <hr/> 2 x #100-5416 1 x #100-5417*	<b>Turf Guards Required</b> <hr/> 2 x #100-5414 1 x #100-5415*	<b>Turf Guards Required</b> <hr/> 2 x #100-5416 1 x #100-5417*
<b>Tines Required</b> <hr/> 32	<b>Tines Required</b> <hr/> 12	<b>Tines Required</b> <hr/> 16	<b>Tines Required</b> <hr/> 12	<b>Tines Required</b> <hr/> 16
<b>Tine Options</b> <hr/> 9.5mm Mini Solid Tine = #100-3622  5m Mini Side Eject Tines = 100-3625	<b>Tine Options</b> <hr/> 19mm Hollow Tine = #86-9720  19mm Side Eject Tine = 92-7900		<b>Tine Options</b> <hr/> 9mm Solid Tine = #100-3626 10mm Solid Tine = #100-3627 11mm Solid Tine = #100-3628 13mm Solid Tine = #100-3629 16mm Solid Tine = #100-3630 10mm Hollow Tine = #100-3633 13mm Hollow Tine = #100-3634 16mm Hollow Tine = #100-3635 16mm Heavy-Duty, Side-Ejection Hollow Tine = #100-3632 19mm Heavy-Duty, Side-Ejection Hollow Tine = #100-3631	

**\*Note: one of these turf guards must be installed in the center position**

# Controls

**Depth Adjustment Handles** (Fig. 16)—Remove the lynch pins, rotate the handles to raise or lower tines to the desired depth and replace the lynch pins.



**Figure 16**

1. Depth adjustment handle
2. Lynch pin

**Depth Guides** (Fig. 17)—Depth guides (1 through 27) are provided to give equal increments for adjustment. The numbers do not relate to measurements of depth as this changes with tine type and amount of tine wear. Adjustment between two numbers will give approximately 0.2 inches (5 mm) change in depth. The higher the number, the deeper the tine penetration. Always adjust each side to the same number.



**Figure 17**

1. Depth guide

# Operation

## Adjust Tine Depth

To adjust the working depth of the tine, proceed as follows:

1. Remove the lynch pin from each depth adjustment handle (Fig. 18).



**Figure 18**

1. Depth adjustment handle

2. Turn the depth adjuster handles to raise (deeper) or lower (shallow) the roller.
3. Depth guides (Fig. 19) are provided with numbers 1 through 27. Depth varies with the mounted angle of aerator, tine type and amount of tine wear. Refer to the *Depth Chart*. Tine depth between two numbers is approximately 0.20 inches (5 mm). The higher the number, the deeper the tine penetration. Always adjust each side to the same number.



**Figure 19**

1. Depth guide

**IMPORTANT:** If a large change in height is required, adjust each leg by a small amount to ensure the roller legs are adjusted as evenly as possible.

**NOTE:** Remember: when depth changes are made, you will need to adjust the top link length to give the correct machine angle. Refer to *Connect the Upper Link*.

**IMPORTANT:** Tine depth is affected by the mounted angle of the aerator, as well as the depth setting. If the aerator is angled rearward, the tine heads may contact the turf guards and damage may occur. Depths 26 & 27 cannot be used when the aerator is in the vertical position. See the *Depth Chart*.

4. Install the depth adjustment handles' lynch pins before running the machine, even if you are just testing for correct depth.

**IMPORTANT:** Tine depth is determined by the tine type, depth adjustment and mounted angle of the aerator. Refer to the *Depth Chart*.

Maximum depth is achieved when the aerator is mounted vertically (Fig. 20) and the depth adjustment set at 25. In this condition, do not operate at greater depth settings, as there is minimal clearance between the tine head and the turf guards. Never operate with

the aerator angled rearward or damage to the turf guards may occur.

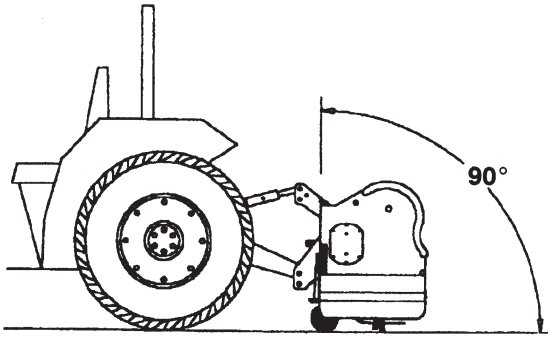

Figure 20

In some instances, angling the aerator forward may improve hole quality but will also reduce aeration depth and gain clearance with the turf guards. A forward angle of approximately 4° is a good initial setting. Use a magnetic-based angle indicator to determine the forward angle, or use the following procedure:

- A. Position the aerator on a flat level surface.
- B. Make sure the aerator roller is on the ground and the depth indicator is set at the desired setting.
- C. Measure and record the distance from the ground to the lower rear corner of the frame (“H1”) and from the ground the front corner of the frame (“H2.”)
- D. Adjust the upper link until the difference between “H1”-”H2” matches the desired forward angle of the aerator (See *Angle Chart* below).

<b>H1-H2</b>	<b>0mm</b>	<b>21mm</b>	<b>43mm</b>	<b>64mm</b>	<b>85mm</b>
<b>Angle</b>	0°	2°	4°	6°	8°

## Depth Chart

Depth Gage	Heavy-Duty & Standard Tines			Mini Tines (102mm long)		
	Installed Angle			Installed Angle		
	0°	4°	8°	0°	4°	8°
1						
2						
3	mm	<b>A</b>		<b>A</b>		
4	3					
5	8					
6	13					
7	18	mm				
8	23	2				
9	28	7				
10	33	13				
11	38	18	mm			
12	43	24	0	mm		
13	48	29	6	1		
14	53	35	11	6		
15	58	40	17	11		
16	63	46	23	16		
17	68	51	28	21	mm	
18	73	57	34	26	5	
19	78	62	39	31	11	
20	83	68	45	36	17	
21	88	73	51	41	23	mm
22	93	79	56	46	29	3
23	98	84	62	51	35	10
24	103	90	68	56	41	17
25	108	95	73	61	47	24
26	<b>B</b>	101	79	<b>B</b>	53	31
27		107	84		60	38

**Key:**

A= Do not operate the aerator in this range-unacceptable results may occur

B= Do not operate the aerator in this range—turf guard damage may occur

In instances where sufficient root growth exists, the turf guards may be removed to attain maximum depth without damaging the turf guards.

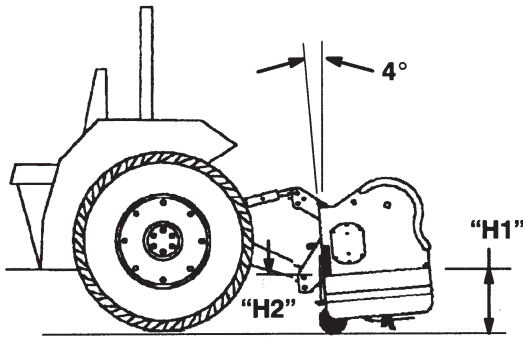

Figure 21



Figure 22

1. Depth guide

**NOTE:** For future reference, record the upper link length that achieves the desired operating angle.

### Tractor Controls

It is necessary to familiarize yourself with the operation of the following tractor controls before you are able to operate the aerator:

- PTO Engagement
- 3-Point Hitch (Raise/Lower)
- Clutch
- Throttle
- Gear Selection

**NOTE:** Refer to the tractor operator's manual for operating instructions.

## Principles Of Operating

The tractor's three-point hitch linkage lifts the aerator for transport and lowers it for operation.

The tractor's power take-off (PTO) power is transmitted via shafts, gearbox and drive belts to a number of crankshafts that drive the tine holding arms into the turf surface. As the tractor travels forward with the PTO engaged and the machine lowered, a series of holes are created in the turf surface.

The depth of the tine's penetration is determined by the mounted angle of the aerator and the height of the depth-control roller.

The distance between the holes created is determined by the tractor's gear ratio (or hydrostatic traction pedal position) and the number of tines in each tine head. Simply changing engine rpm does NOT change hole spacing.

## Training Period

Before using the aerator, find a clear area and practice using the machine. Operate the tractor at the recommended gear settings and PTO drive speeds and become thoroughly familiar with machine's handling. Practice stopping and starting, raising and lowering the aerator, disengaging the PTO drive and aligning the machine with previous passes. A practice session assures confidence in the performance of the aerator and promotes proper operating techniques wherever the machine is operated.

If there are sprinkler heads, electrical or communication lines or other obstructions in the area to be aerated, mark these items to assure they are not damaged during operation.

⚠
CAUTION
⚠

To avoid personal injury, never leave the tractor seat without first setting the parking brake and disengaging the PTO drive. Never perform aerator repairs without lowering the aerator onto the castor/safety stand. Be sure all safety devices are secured in proper place before resuming operation.

## Before Aerating

Inspect the area of operation for hazards that could damage the machine and remove them, if possible, or plan how to avoid them. Carry replacement tines and tools for repairs should tines contact foreign materials.

## Aerating Procedures

1. Lower the aerator on the 3-point linkage so that the tines are nearly to the ground at the lowest part of their stroke.
2. At a low tractor engine rpm, engage the power take-off (PTO) clutch to start the aerator working.

**IMPORTANT: Do not operate the aerator at 540 PTO rpm when lifted out of the ground. This machine can be damaged if operated at full speed without the tines working in the turf. Never operate the aerator without tine heads installed**

3. Select a gear that gives a forward speed of approximately 0.6–2.5 MPH (1 to 4 km/hr) at rated PTO speed. (Refer to the tractor operator's manual)
4. As the clutch is released and the tractor moves forward, lower the machine fully into work and increase engine speed to give a maximum of 540 rpm at the PTO.

**NOTE:** When using needle-tine heads, make sure to read the instructions, included with the kit, for unique operating procedure.

**IMPORTANT: Never operate the tractor PTO in excess of 540 rpm or damage to the aerator could occur.**

5. Note the hole pattern. If you need greater hole spacing, increase the tractor's forward speed by changing up a gear or, with a hydro-static drive tractor, shift the hydrostat lever or pedal to give faster speed. For closer hole spacing, decrease tractor forward speed. Changing engine speed, in a particular gear, WILL NOT change the hole

pattern. Operate at an engine speed in which the aerator runs smoothly.

**IMPORTANT: Look behind frequently to ensure the machine is operating properly and alignment is maintained with previous passes.**

6. Use the front tractor wheel as a guide to maintain equal lateral hole spacing with the previous pass.
7. At the end of the aeration pass, raise the aerator, lower the engine rpm and disengage the PTO.
8. If you back into a tight area (like a tee box), disengage the PTO and raise the aerator to its highest position. Use caution not to catch the turf guards on the turf.
9. Always clear the area of all damaged machine parts, such as broken tines, etc., to prevent their being picked up by mowers or other turf maintenance equipment.
10. Replace broken tines, inspect, and correct damage to those still usable. Repair any other machine damage before operating.

## Transport Operation

To begin transport operation, raise the aerator and disengage the PTO. To avoid loss of control, traverse steep inclines slowly, approach rough areas at reduced speed and cross severe undulations carefully.

**Important: Do not exceed transport speeds of 15 mph (24 km/hr).**

**CAUTION:** Do not exceed the maximum or minimum tractor tire inflation pressures as recommended by tire manufacturer.

## Inspection And Clean-Up After Use

After daily use, thoroughly wash the machine with a garden hose without a nozzle to avoid contamination and seal-and-bearing damage due to excessive water pressure. A brush may be used to remove caked-on material.

Use mild detergent to clean the covers. Applying a coat of auto wax periodically will retain the covers' glossy finish. After cleaning, inspect for machine damage, gear oil leakage, component and tine wear.

## Operating Tips

1. Gradually engage the PTO at low engine speed while increasing throttle to 540 PTO rpm (maximum) while lowering the aerator. Operate at engine rpm in which the aerator runs most smoothly.

**NOTE:** Changing engine/PTO rpm in a particular tractor gear (or fixed hydrostatic pedal position on tractors with hydrostatic transmission) will NOT change forward hole spacing

**IMPORTANT:** Do not operate the PTO at high rpms for extended time periods when the aerator is out of the ground.



2. Make very gradual turns when aerating. Never make sharp turns with the PTO drive engaged. Plan your aeration path before lowering the aerator.
3. If the tractor “bogs” down when operating on hard ground or going uphill, raise the aerator slightly until speed is regained, then lower the aerator again.
4. Do not aerate if ground is too hard or dry. Best results are obtained after a rain or when turf has been watered the previous day.

**NOTE:** If the roller rides off the ground while aerating, the ground is too hard to achieve the

desired depth. Reduce the aeration depth until the roller contacts the ground during operation.

5. Raise the aerator penetration if ground is hard packed. Clean the cores and re-aerate at deeper penetration, preferably after watering.
6. The aerator is offset to one side to allow aerating without driving over the cores with the tractor tires. Whenever possible, aerate with the longer offset towards the previous aeration pass.
7. Always check/adjust the top link whenever aeration depth is changed. The front of the aerator should be vertical or angled slightly forward. Experiment with depth and angle to achieve best hole quality.

**NOTE:** After optimum hole quality is attained, record the depth setting and the upper link length for future reference.

	<b>CAUTION</b>	
<p>To avoid personal injury, never leave the tractor seat without first setting the parking brake and disengaging the PTO drive. Never perform aerator adjustments or repairs without first lowering the aerator onto the castor/safety stand. Be sure all safety devices are secured in proper place before resuming operation.</p>		

### Optional Core Windrower

When using hollow tines, an Optional Core Windrower (Toro Model No. 09731) is available to place cores in narrow rows behind the machine.

### Optional Core Following Kit (Not recommended for use on greens)

An Optional Contour Following Kit (Toro Model No. 09154) is recommended for aeration on undulating or uneven surfaces.

# Maintenance

## Greasing Bearings And Bushings

The main working bearings of the aerator are sealed for life and require no maintenance or lubrication. This drastically reduces the maintenance required and eliminates the risk of grease or oil being dropped onto the turf.

There are grease fittings that must be lubricated with an SAE multi-purpose, high -temperature grease with high pressure (EP) performance or SAE multi-purpose lithium base grease.

The lubrication intervals and points are:

**LUBRICATE DAILY**—PTO shaft (4) (Fig. 23).



Figure 23

**LUBRICATE WEEKLY**—Roller Bearings (2) (Fig. 24), Depth Jacks (2) (Fig. 25), Drive Shaft Bearings (2) (Fig. 26).



Figure 24

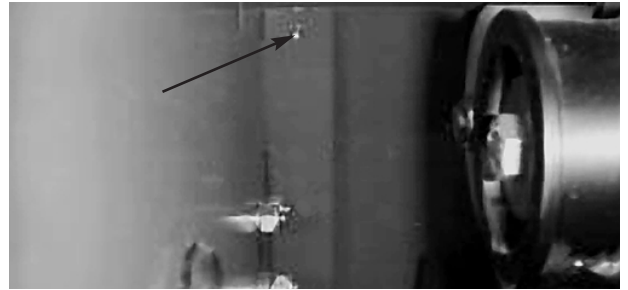

Figure 25

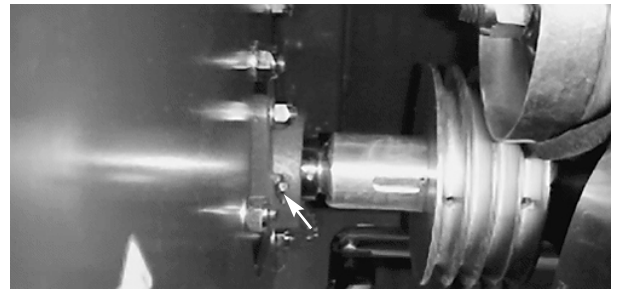

Figure 26

## Gearbox Lubrication

The gearbox is filled with 85/140 gear oil or equivalent.

Check gearbox oil level every 6 months or 100 hours.

1. Remove the check plug at the rear of the gearbox.
2. Make sure oil is up to bottom of the plug hole in the gearbox.
3. If oil level is low, remove fill plug on top of the gearbox and replenish oil as required.
4. Install the plug.

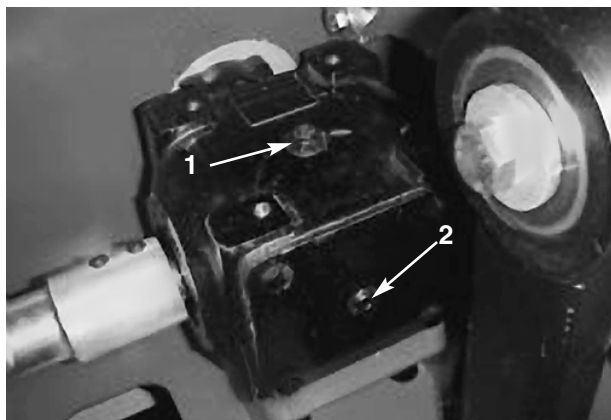

Figure 27

1. Check plug
2. Fill plug

## Torque Set Screws

After the first 10 hours of operation, and every 50 hours thereafter, torque the set screws securing the taper lock bushings to driven pulleys to 37 ft. lbs. (50 N-m) (2 each pulley) (Fig. 28).

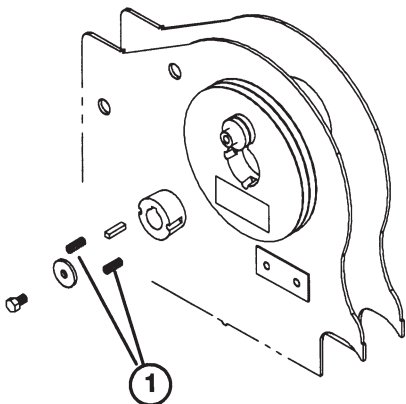

Figure 28

1. Bushing set screws

After the first 10 hour of operation, and every 50 hours thereafter, torque the set screws securing drive shafts to gear box shafts to 20-25 ft. lbs. (26-32 N-m) (4 each side) (Fig. 29).

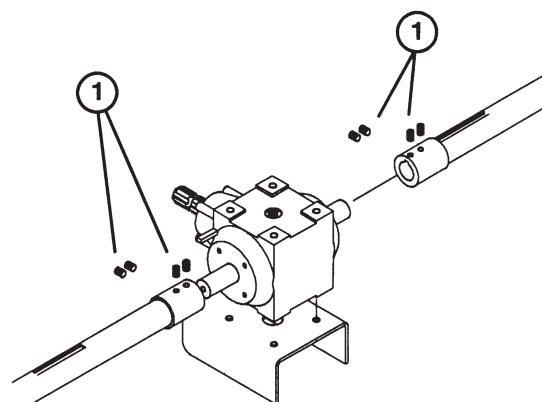

Figure 29

1. Drive shaft set screws

## Adjusting Pulley Scrapers

To prevent build-up of dirt sand or other debris in the pulley grooves, make sure the pulley scrapers are adjusted correctly.

1. Loosen the lock nut securing the pulley scrapers to the mounting bracket (Fig. 30)

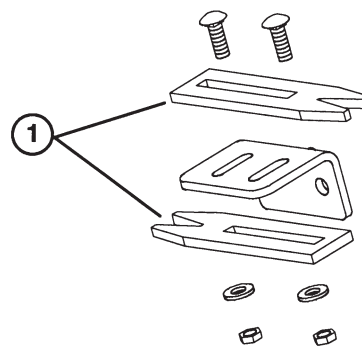

Figure 30

1. Pulley scrapers

2. Slide the pulley scrapers until they almost contact the sides of the pulley groove(s).
3. Tighten the nut to lock adjustment.

## Adjusting Belt Tension

Check belt tension after every few hours of operation. Make sure belts are properly tensioned to assure correct operation of unit and unnecessary wear, and whether they may cause poor hole quality in some conditions.

1. Check tension by depressing the belt upward at the lower midspan of the pulleys with 14 Kg of force. The belt should deflect 3–5 mm. If the deflection is incorrect, go to the next step. If it is correct, continue operation.
2. To adjust belt tension:
  - A. While holding the bolt (Fig. 31), loosen the nut securing the idler pulley (Fig. 32)

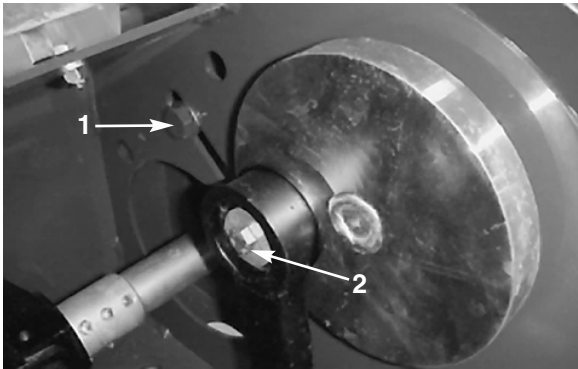

**Figure 31**

1. Idler pulley bolt
2. Tine arm bolt (R.H and L.H. threads)

- B. Insert a pry bar into the frame slot (Fig. 32) and pry the idler toward the belt.
- C. Tighten the nut while maintaining pressure on the pry bar.

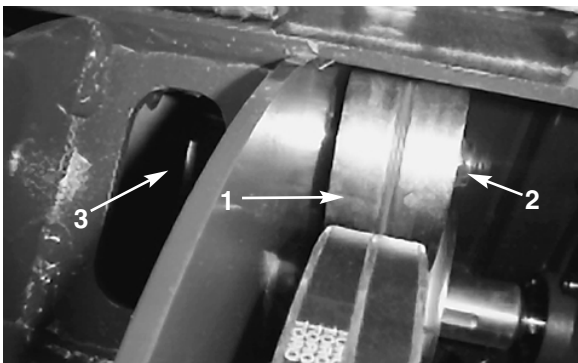

**Figure 32**

1. Idler pulley
2. Idler pulley nut
3. Frame slot

- D. Rotate the crankshaft pulley two full turns to seat the belt in the pulley grooves.
- E. Check belt tension.

## Replacing Belts

1. Loosen the idler pulley nut to release tension on the belt (Fig. 32).
2. remove the idler pulley nut and remove the pulley.
3. Loosen the tine arm bolts (right-hand and left-hand threads).
4. Remove the fasteners securing the bottom of the tine arm or rotalink arm to the bottom links (Fig. 33). Align the tine arm with the slot in the frame and slide off the crank pin.



**Figure 33**

1. Tine arm
2. Bottom link
3. Rotalink arm
4. Lower link bearings

5. To ensure components are re-installed correctly, mark the location of the end cover on the aerator frame (Fig. 34).
6. Remove the eight cap screws and flat washers securing the end over and bearing housing to the end of the aerator frame.

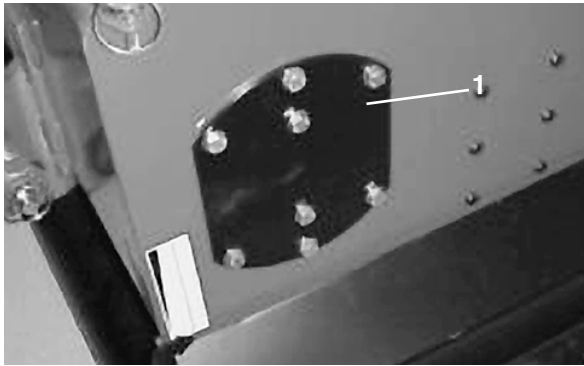

Figure 34

1. End cover

7. Loosen the bearing's set screws (Fig. 35)

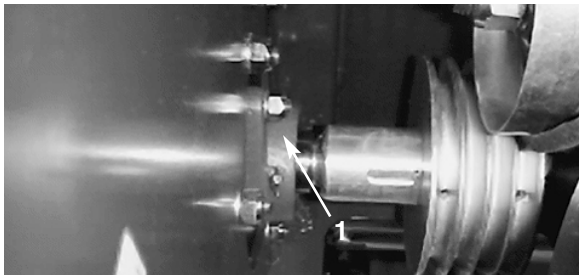

Figure 35

1. Bearing

8. Remove the end cover and bearing.

**Note:** Remove only the end cover necessary to access belts being removed, i.e.,

Left cover—Left belts

Right cover—Right belts

9. Slide the belts off the pulleys.
10. Remove the belts from the aerator by routing them over the drive shaft, through holes in frame center plates, over bearings and out the hole in the end of the frame.
 

**IMPORTANT: When changing belts, always change both belts on the pulley.**
11. Route the new belts over the drive shaft and onto the pulleys.
12. Reinstall the end cover onto the drive shaft. At the location marked on the frame, secure the end cover to the aerator frame with the cap screws

and flat washers removed earlier.

13. Reinstall the top of the tine arm to pulley with a screw, lock washer and flat washer (right-hand and left-hand threads).
14. Reinstall the bottom of the tine arm to the bottom links or rotalink arm with the removed fasteners.
15. Adjust belt tension. Refer to *Adjusting Belt Tension*.

**Note:** The heavy-duty sealed bearings used in the lower links of the ProCore 660 and 880 aerators may also be used as replacement bearings in the lower links for the ProCore 440 (Fig. 33). When the wider heavy-duty bearings are used, eliminate the flat washer/spacers normally used with narrower bearings.

## Storage

At the end of an aerating season or when the aerator will not be used for a long period, it is good practice to do the following preventative maintenance.

1. Clean off any dirt or grease that may have accumulated on the aerator or any of the moving parts.
2. Remove the tines and clean out the hollow tines. Coat tines with oil to prevent rusting during storage.
3. Open the hood and clean out the inside of the machine.
4. Lubricate all grease fittings.
5. Store the machine with the roller and castor wheel standing on a hard, dry surface or board and block the roller.
6. Remove the PTO drive shaft and store it under the hood
7. Paint the roller and touch up any other scratches on the paint work.

8. Replace any missing or damaged decals.
9. Store the aerator inside a dry, secure building. Inside storage will reduce maintenance, give a longer working life and increase the residual value of the machine. If inside storage is not available, cover the aerator with a heavy sheet or tarpaulin and secure it tightly.

## Identification And Ordering

### Model and Serial Numbers

The aerator has two identification numbers: a model number and a serial number. The two numbers are stamped on a plate that is riveted to the center frame plate, under the hood (Fig. 36). In any correspondence concerning the aerator, supply the model and serial numbers to be sure you receive correct information and replacement parts.

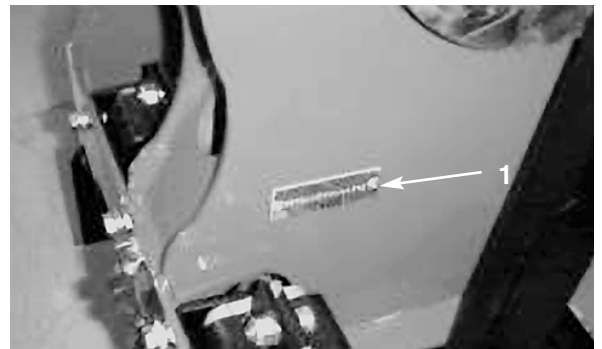

**Figure 36**

1. Model & serial number plate

To order replacement parts from an authorized TORO Distributor, supply the following information:

1. Model and serial numbers of the machine.
2. Part number, description and quantity of parts desired.

**Note:** Do not order by reference number if a parts catalog is being used; use the part number.