



Count on it.

Parts Catalog

Super Recycler®

Lawn Mower

Model No. 21387—Serial No. 405700000 and Up



Ordering Replacement Parts

To order replacement parts, please supply the part number, the quantity, and the description of each part desired.

Understanding Reference Numbers

Each identified part in an illustration has a reference number. The reference number for a part also appears in the parts list, along with other information about the part.

This catalog uses two special reference number formats, one to indicate parts in a service assembly and another to indicate the quantity of a given part in an illustration.

Service Assembly Reference Numbers

Parts in service assemblies have reference numbers in the form a:b. The a represents the reference number of the entire service assembly and the b represents a sequential number unique to each part within the service assembly.

For example, a wheel assembly might be identified by reference number 6, the tire by 6:1, the valve by 6:2, and the wheel by 6:3. When you order the assembly identified by reference number 6, you receive all parts identified by reference numbers 6:1, 6:2, and 6:3. However, you may also order any part individually. Reference numbers of this type appear in illustration and in parts lists.

Reference Numbers Indicating Quantity

In an illustration, if a reference number indicates more than one part, the reference number has the form nX y. The n represents the quantity of the part, the X is the multiplication symbol, and the y represents the reference number.

For example, in an illustration, the reference number 2X 37 means that two of the parts identified by reference number 37 are indicated.

Contents

Housing Assembly	4
Rear Door and Mulch Plug Assembly	6
Bag Assembly	8
Engine and Blade Assembly	10
Front Wheel and Height-of-Cut Assembly	12
Transmission and Rear Wheel Height-of-Cut Assembly	14
Electrical Assembly	16
Handle Assembly	18
Attachments and Accessories	20

Housing Assembly

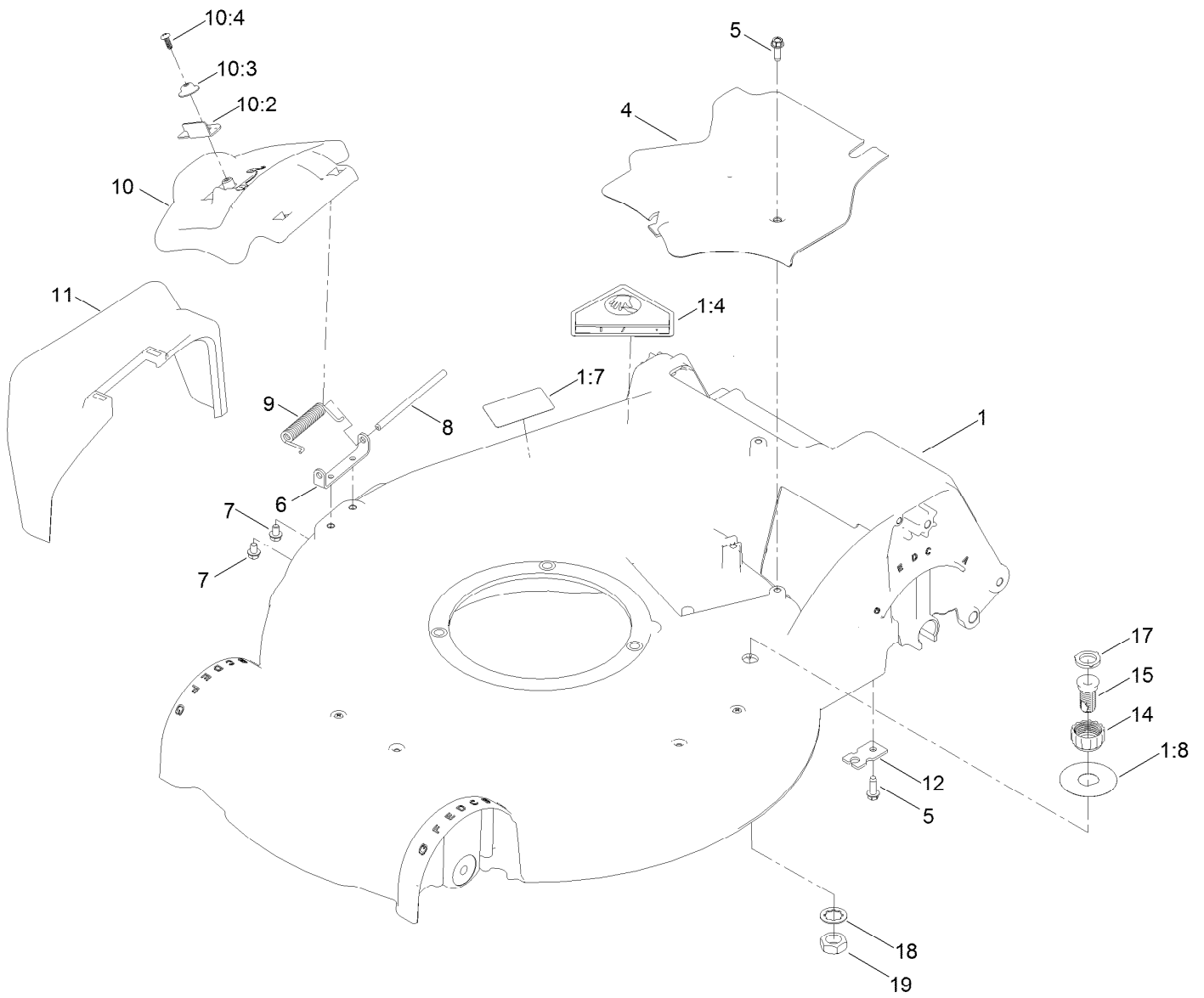

Housing Assembly (continued)

<i>Ref.</i>	<i>Part Number</i>	<i>Qty.</i>	<i>Description</i>	<i>Ref.</i>	<i>Part Number</i>	<i>Qty.</i>	<i>Description</i>
1	140-3768	1	Housing ASM	10:2	138-3221	1	Latch-Door
1:4	94-8072	1	Decal-Danger	10:3	138-3242	1	Cap-Door
1:7	125-5092	1	Decal-Placement, Foot	10:4	137-9137	1	Screw-PPH
1:8	137-9196	1	Decal-Quick Wash	11	108-3753	1	Chute-Discharge, Side
4	107-7494	1	Cover-Belt	12	138-3224	1	Bracket-Cable, Traction
5	49-2040	2	Screw-HWHTF	14	112-6401	1	Coupling-Hose, Washout Port
6	112-6416	1	Bracket-Cover	15	112-6400	1	Port-Washout
7	137-4795	2	Screw	17	112-6438	1	Washer-Seal, Washout Port
8	99-5291	1	Rod-Cover	18	3254-5	1	Washer-Lock
9	99-5293	1	Spring-Torsion	19	3218-6	1	Nut-Jam
10	107-3717	1	Discharge Door ASM				

Rear Door and Mulch Plug Assembly

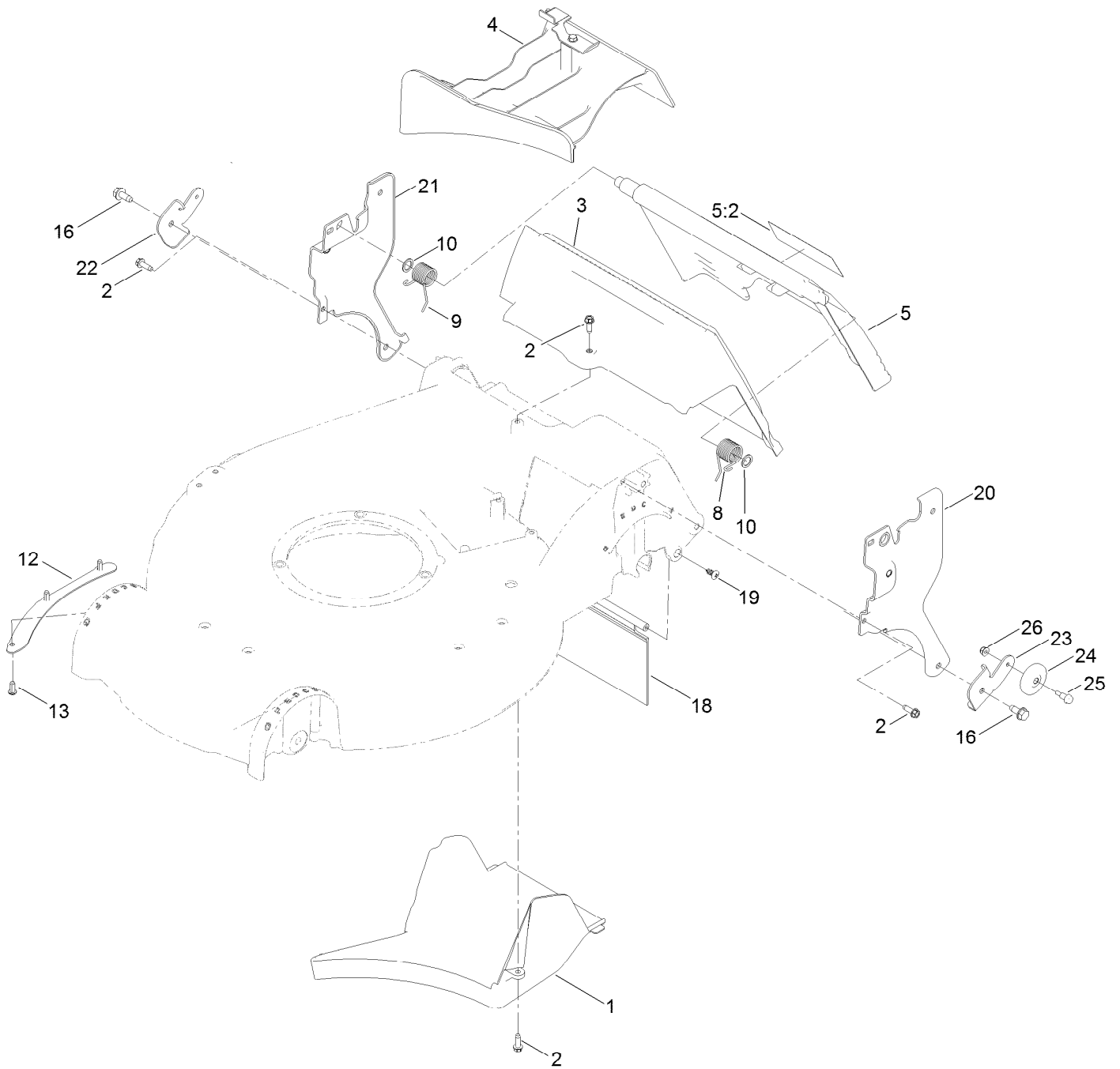

Rear Door and Mulch Plug Assembly (continued)

<i>Ref.</i>	<i>Part Number</i>	<i>Qty.</i>	<i>Description</i>	<i>Ref.</i>	<i>Part Number</i>	<i>Qty.</i>	<i>Description</i>
1	107-7495	1	Tunnel-Discharge	16	32144-70	2	Screw-HWHTF
2	49-2040	5	Screw-HWHTF	18	120-7011	1	Shield-Trailing
3	114-2668	1	Chute	19	117-1092	2	Screw-PTH
4	115-8413	1	Mulch Plug ASM	20	137-9108	1	Plate-Handle, LH
5	137-9139	1	Rear Door ASM	21	137-9107	1	Plate-Handle, RH
5:2	131-4514	1	Decal-Warning	22	140-1286-03	1	Bracket-Smartstow, RH
8	115-2859	1	Spring-Torsion	23	140-1287-03	1	Bracket-Smartstow, LH
9	114-7924	1	Spring-Torsion	24	106-9799	2	Wheel-Sweep
10	94-8196	2	Washer-Nylon	25	140-1292	2	Screw-Shoulder
12	105-1316-01	1	Lip-Housing	26	138-0719	2	Nut-HF
13	63-8590	3	Screw				

Bag Assembly

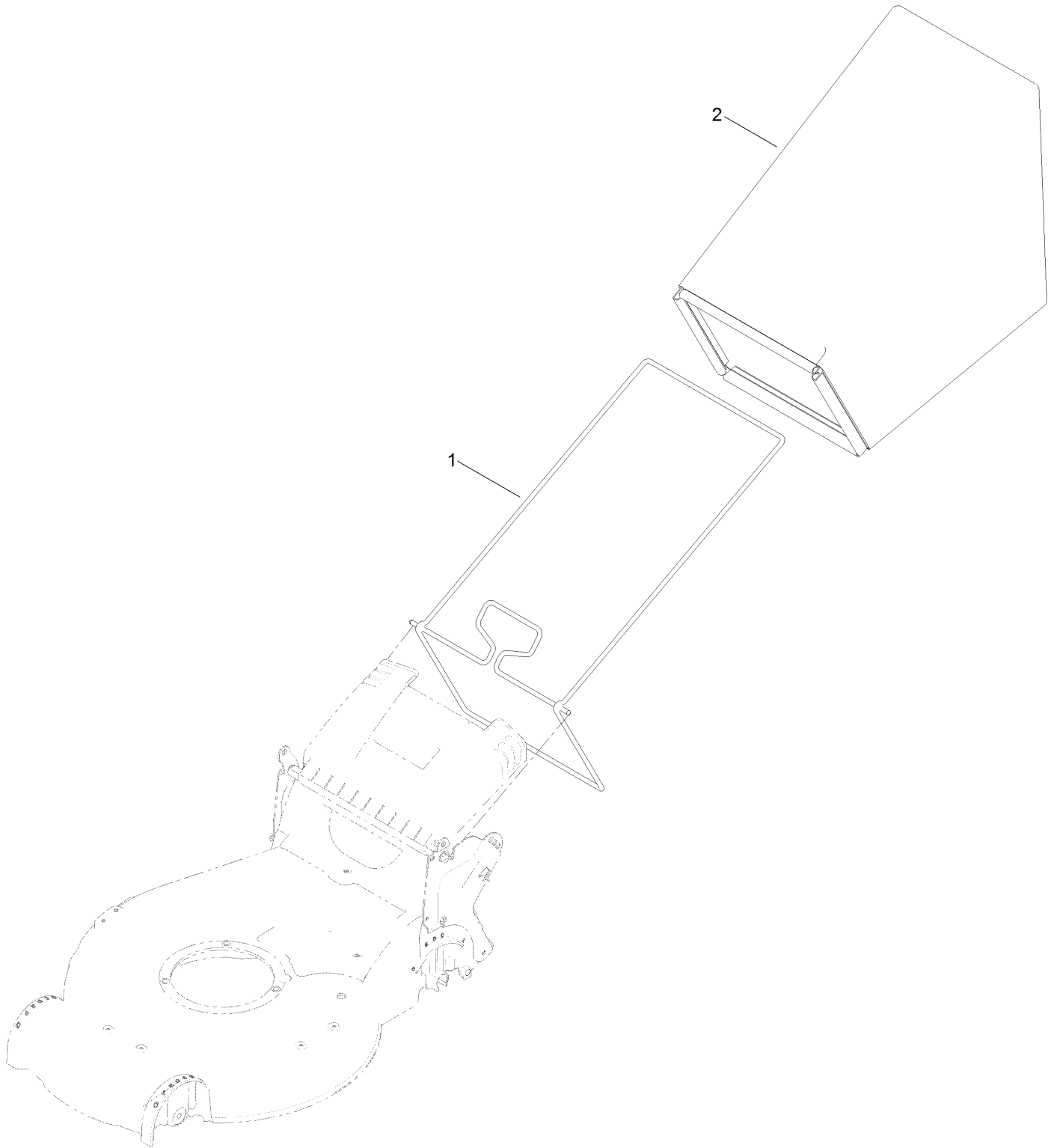

Bag Assembly (continued)

<i>Ref.</i>	<i>Part Number</i>	<i>Qty.</i>	<i>Description</i>
1	132-4529-03	1	Bag Frame ASM
2	114-2664	1	Grass Bag ASM

Engine and Blade Assembly

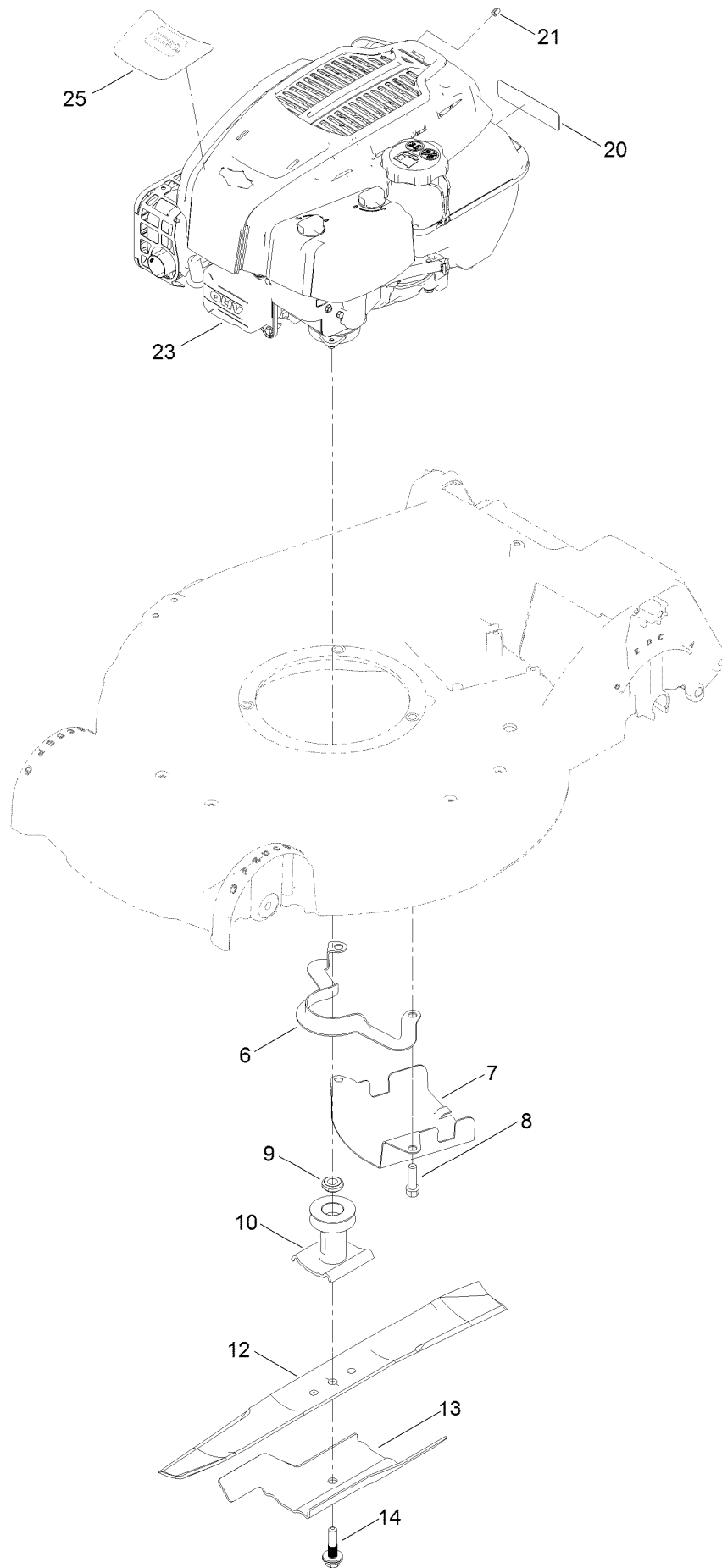

Engine and Blade Assembly (continued)

<i>Ref.</i>	<i>Part Number</i>	<i>Qty.</i>	<i>Description</i>	<i>Ref.</i>	<i>Part Number</i>	<i>Qty.</i>	<i>Description</i>
6	108-8110-03	1	Guide-Belt	14	125-2466	1	Bolt-Blade
7	107-7489-03	1	Shield-Grass	20	133-8062	1	Decal-Arrestor, Spark
8	95-1727	3	Screw-Taptite	21	2210-316	1	Stop-Rope
9	106-3999	1	Spacer-Driver	23		1	Engine-Briggs 875 ES SS ●
10	106-3987	1	Driver-Blade				■
12	133-8183-03	1	Blade-Recycling, 21In	25	140-3774	1	Decal-Engine
13	105-6848-01	1	Accelerator-Blade				

● Not serviced separately

■ Obtain parts from www.briggsandstratton.com

Front Wheel and Height-of-Cut Assembly

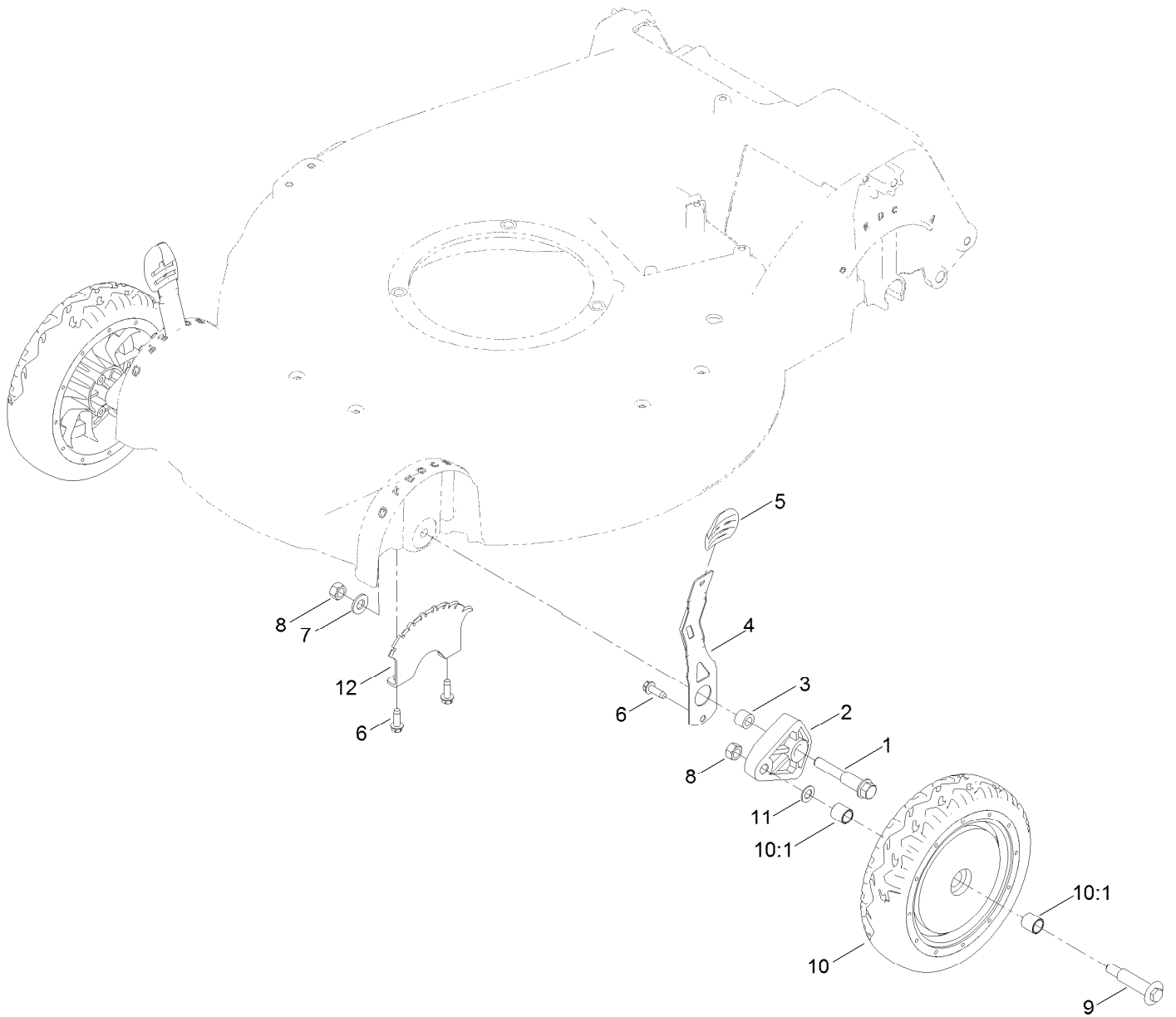

Front Wheel and Height-of-Cut Assembly (continued)

<i>Ref.</i>	<i>Part Number</i>	<i>Qty.</i>	<i>Description</i>	<i>Ref.</i>	<i>Part Number</i>	<i>Qty.</i>	<i>Description</i>
1	114-3467	2	Screw-Shoulder	8	603773	4	Locknut
2	107-7492	2	Arm-Pivot	9	92-1057	2	Bolt-Shoulder
3	52-2480	2	Spacer-Wheel	10	140-1294	2	Wheel ASM
4	107-7491	2	Arm-Spring	10:1	27-6250	2	Bushing
5	105-3042	2	Knob-Lever, HOC	11	40-1940	2	Washer
6	49-2040	6	Screw-HWHTF	12	139-1669-01	2	Plate-HOC
7	3256-24	2	Washer-Flat				

Transmission and Rear Wheel Height-of-Cut Assembly

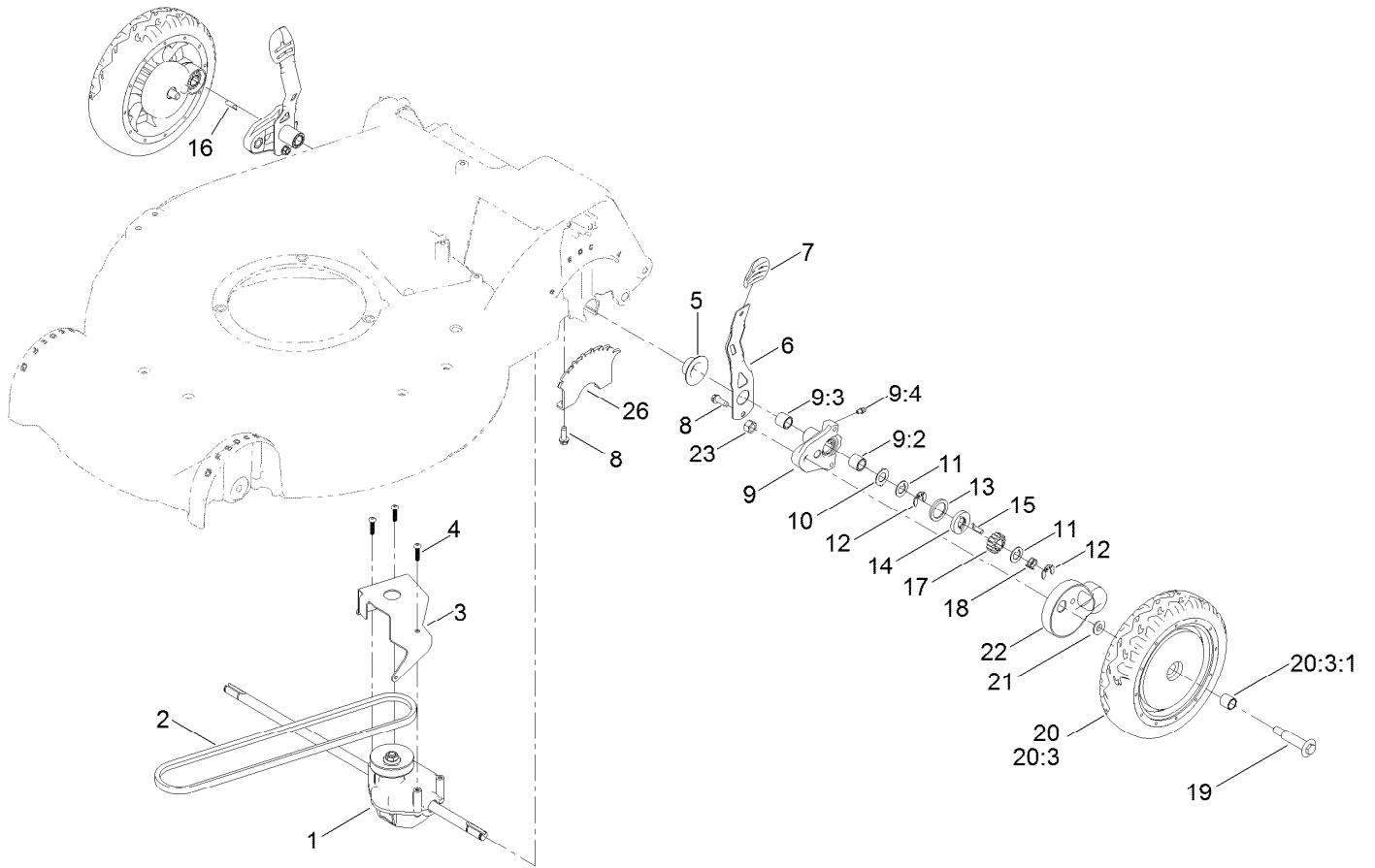

Transmission and Rear Wheel Height-of-Cut Assembly (continued)

<i>Ref.</i>	<i>Part Number</i>	<i>Qty.</i>	<i>Description</i>	<i>Ref.</i>	<i>Part Number</i>	<i>Qty.</i>	<i>Description</i>
1	121-9184	1	Transmission ASM	13	65-4710	2	Ring-Friction
2	115-4669	1	Belt-V	14	65-4760	2	Washer-Clutch
3	114-7977-03	1	Bracket-Transmission	15	139-6644	1	Key-Rocking, L.H.
4	108-7476	3	Screw-Plastite	16	139-6643	1	Key-Rocking, R.H.
5	138-3235	2	Cap-End	17	65-4750	2	Gear-Pinion
6	107-7491	2	Arm-Spring	18	65-4720	2	Spring-Compression
7	105-3042	2	Knob-Lever, HOC	19	92-1057	2	Bolt-Shoulder
8	49-2040	6	Screw-HWHTF	20	140-1295	2	Wheel Gear ASM
9	100-8774	2	Pivot Arm ASM	20:3		1	Wheel ASM ●
9:2	47-2900	1	Bushing	20:3:1	27-6250	2	Bushing
9:3	70-9760	1	Bushing	21	74-1671	2	Spacer-Cover, Wheel
9:4	302-56	1	Fitting-Grease	22	74-1660	2	Cover-Wheel
10	65-4730	2	Washer-Arm, Pivot	23	603773	2	Locknut
11	65-4740	4	Washer-Thrust, Keyed	26	139-1669-01	2	Plate-HOC
12	65-2720	4	Ring-Retaining, Clip				

● Not serviced separately

Electrical Assembly

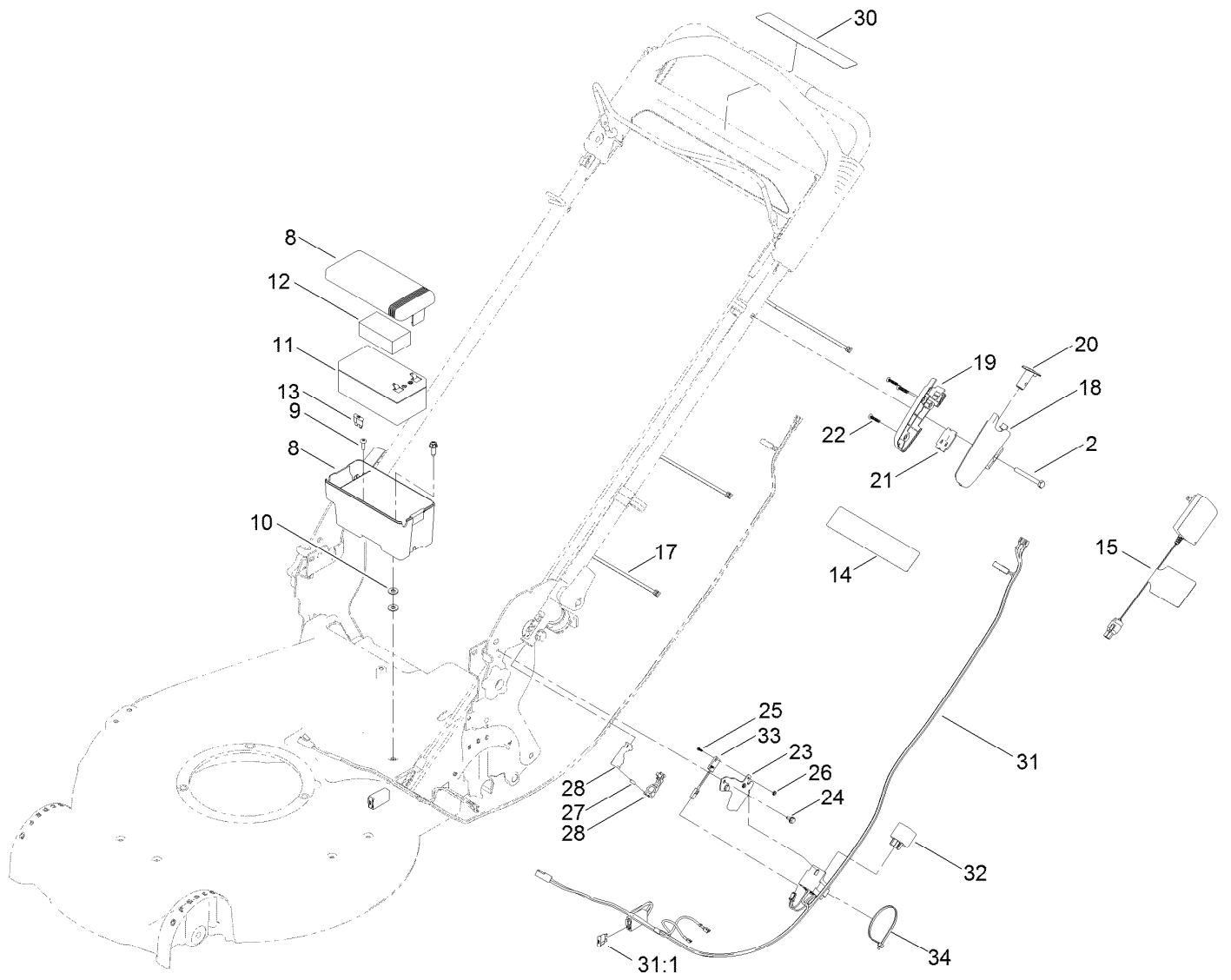

Electrical Assembly (continued)

<i>Ref.</i>	<i>Part Number</i>	<i>Qty.</i>	<i>Description</i>	<i>Ref.</i>	<i>Part Number</i>	<i>Qty.</i>	<i>Description</i>
2	321-50	1	Screw-HH	22	94-4496	3	Screw-PPH
8	108-4844	1	Battery Box ASM	23	140-3828-03	1	Bracket-Sensor
9	32144-32	1	Screw	24	104-2065	2	Screw-HWH
10	120-9679	2	Washer-Flat	25	360-0224	2	Screw
11	106-8397	1	Battery-Wet	26	3296-52	2	Nut-Lock, NI
12	107-3774	1	Foam-Battery, Top	27	114-5896	1	Magnet
13	99-6124	1	Fuse-40 Amp	28	140-3806	2	Housing-Magnet
14	104-7953	1	Decal-Warning	30	133-1900	1	Decal-Button, Push
15	136-9126	1	Charger, Battery (12V)	31	140-3761	1	Harness-Wire
17	3290-379	3	Tie-Cable	31:1	99-6124	1	Fuse-40 Amp
18	133-8160	1	Housing-Switch, LH	32	1-643275	1	Relay
19	133-8161	1	Housing-Switch, RH	33	140-3832	1	Reed Switch ASM
20	125-2470	1	Button-Switch	34	3290-379	1	Tie-Cable
21	121-9173	1	Switch-Push Button				

Handle Assembly

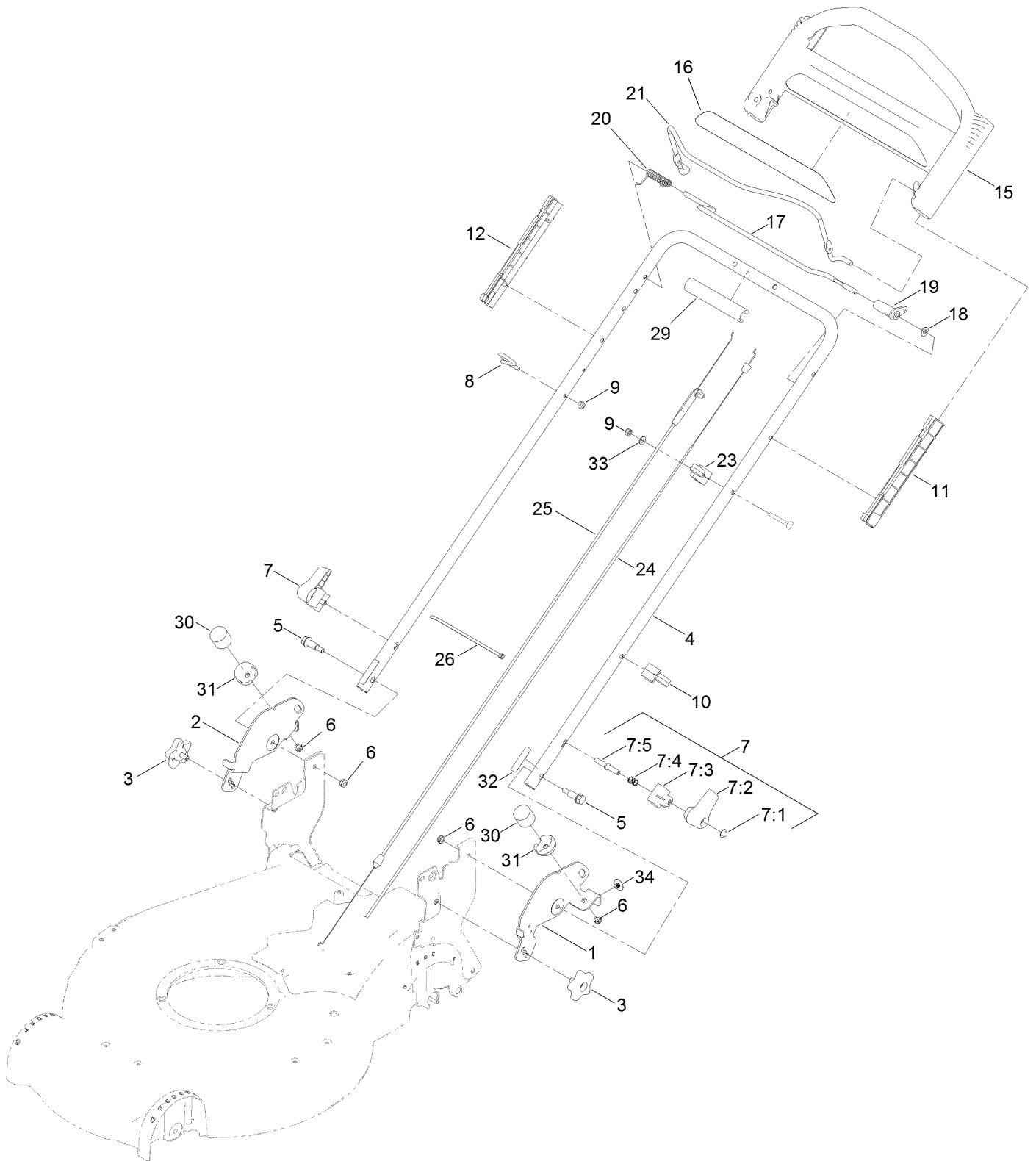

Handle Assembly (continued)

<i>Ref.</i>	<i>Part Number</i>	<i>Qty.</i>	<i>Description</i>	<i>Ref.</i>	<i>Part Number</i>	<i>Qty.</i>	<i>Description</i>
1	140-3831-03	1	Bracket-Float, LH	15	104-8678	1	Handle-Control
2	137-4838-03	1	Bracket-Float, RH	16	140-3821	1	Decal
3	137-4844	2	Knob-Handle	17	136-7150	1	Bar-Control, Traction
4	140-3824-05	1	Handle-Upper	18	3256-23	1	Washer-Plain
5	130-2344	2	Bolt-Shoulder	19	99-1589	1	Lever-Traction
6	3296-47	4	Nut-Lock, NI	20	136-7166	1	Spring-Torsion
7	138-3249	2	Quick Release ASM	21	131-0880-03	1	Bail-Brake
7:1	32112-11	1	Nut-Push	23	136-5864	1	Anchor-Cable
7:2	138-3248	1	Lever-Release	24	117-9389	1	Cable-Traction
7:3	138-3253	1	Anchor-Spring	25	117-5900	1	Cable-Brake
7:4	115-2858	1	Spring-Compression	26	614249	3	Tie-Cable
7:5	138-3243	1	Rod-Release	29	131-4551	1	Cover-Handle
8	86-9671	1	Guide-Rope	30	137-4803	2	Bumper-Rubber
9	3296-73	2	Nut-Lock, NI	31	137-9100	2	Cover-Bumper
10	114-7988	1	Guide-Cable	32	140-3827	2	Decal-Flex
11	105-6842	1	Guide-LH	33	3256-1	1	Washer-Flat
12	105-6841	1	Guide-RH	34	130-6721	2	Clip-Tree

Attachments and Accessories

For 21387 Super Recycler Lawn Mower

Product Name	Model/Part
Bagging Blade	108-3759-03
Briggs Maint Kit.....	130-8148
4-Cycle Fuel, Snow And Lawn 32oz Can	131-3823
Traction Assist Handle Kit.....	131-4590
Toro Premium Fuel Treatment 12 Oz Bottle	131-6572
Oil-30/10W-30 Synthetic (Quart).....	138-6053
Toro 4-Cycle SAE 30 Oil (32oz Bottle)	38903
Summer Oil-Case of 24 (20oz Bottles).....	38916
Bag-Walk Behind (Toro).....	490-7318
Lawnmower Cover.....	490-7462

Notes:

Notes:

Notes:



Count on it.