



**Backhoe**  
**Dingo<sup>®</sup> Attachment**  
Model No. 22412—200000001 & Up

**Operator's Manual**





# Contents

	Page
Introduction .....	2
Safety .....	2
Safety Decals .....	3
Specifications .....	4
Stability Ratings .....	4
Setup .....	5
Loose Parts .....	5
Installing the Side Bar Bracket .....	5
Changing the Tilt Cylinder Pin .....	6
Greasing the Backhoe .....	6
Installing a Bucket .....	6
Adjusting the Seat .....	7
Operation .....	8
Operation Checklist .....	8
Backhoe Overview .....	8
Controls .....	8
Connecting the Backhoe to the Traction Unit ...	9
Operating the Backhoe .....	11
Securing the Backhoe for Transport .....	12
Disconnecting the Backhoe from the Traction Unit .....	13
Maintenance .....	14
Service Interval Chart .....	14
Greasing and Lubrication .....	14
Changing the Bucket Orientation .....	15
Changing the Boom Speed .....	15
Storage .....	16
Troubleshooting .....	16

## Introduction

We want you to be completely satisfied with your new product, so feel free to contact your local Authorized Service Dealer for help with service, genuine replacement parts, or other information you may require.

Whenever you contact your Authorized Service Dealer or the factory, always know the model and serial numbers of your product. These numbers will help the Service Dealer or Service Representative provide exact information about your specific product. You will find the model and serial number on a plate located on the product.

For your convenience, write the product model and serial numbers in the space below.

**Model No:** \_\_\_\_\_

**Serial No.** \_\_\_\_\_

The warning system in this manual identifies potential hazards and has special safety messages that help you and others avoid personal injury, even death. **DANGER**, **WARNING** and **CAUTION** are signal words used to identify the level of hazard. However, regardless of the hazard, be extremely careful.

**DANGER** signals an extreme hazard that will cause serious injury or death if the recommended precautions are not followed.

**WARNING** signals a hazard that may cause serious injury or death if the recommended precautions are not followed.

**CAUTION** signals a hazard that may cause minor or moderate injury if the recommended precautions are not followed.

Two other words are also used to highlight information. “Important” calls attention to special mechanical information and “Note” emphasizes general information worthy of special attention.

The left and right side of the machine is determined by standing in the normal operator’s position.

## Safety

**Improper use or maintenance by the operator or owner can result in injury. To reduce the potential for injury, comply with the safety instructions in the traction unit operator’s manual and always pay attention to the safety alert ▲ symbol, which means CAUTION, WARNING, or DANGER—“personal safety instruction.” Failure to comply with the instruction may result in personal injury or death.**

**! DANGER !**

**POTENTIAL HAZARD**

- There may be buried power, gas, and/or telephone lines in the work area.

**WHAT CAN HAPPEN**

- Electric shock, death, or explosion may occur.

**HOW TO AVOID THE HAZARD**

- Have the property or work area marked for buried lines and do not dig in marked areas.

**! WARNING !**

**POTENTIAL HAZARD**

- When going up or down hill, the machine could overturn if the heavy end is toward the downhill side.

**WHAT CAN HAPPEN**

- Someone may be pinned or seriously injured by the machine if it overturns.

**HOW TO AVOID THE HAZARD**

- Operate up and down slopes with the backhoe uphill.

**! DANGER !**

**POTENTIAL HAZARD**

- There may be overhead power lines in the work area.

**WHAT CAN HAPPEN**

- Electric shock or death may occur if a power line is touched by the backhoe.

**HOW TO AVOID THE HAZARD**

- Survey and mark the area where there are overhead power lines, and dig with caution under power lines, to ensure that you do not touch them with the backhoe.

**! CAUTION !**

**POTENTIAL HAZARD**

- The tires of the traction unit can be slippery.

**WHAT CAN HAPPEN**

- If the tires are used as a step to climb on to or off of the backhoe, the operator could slip and fall, causing injury.

**HOW TO AVOID THE HAZARD**

- Use the step provided when climbing on to or off of the backhoe and not the traction unit tires.

## Safety Decals

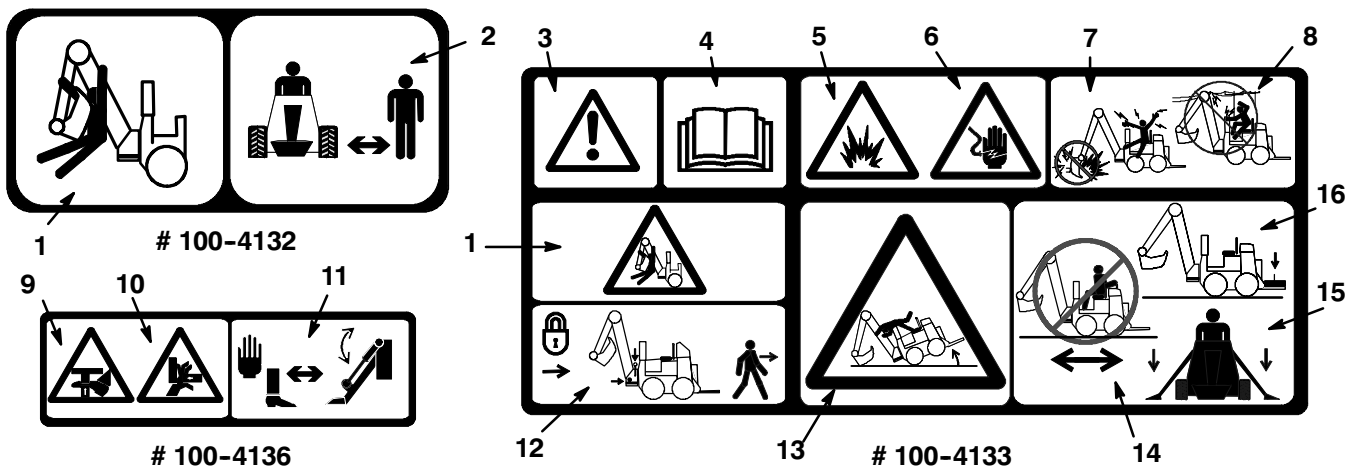

Figure 1

- |                               |   |  |   |
|-------------------------------|---|--|---|
| 1. Crushing hazard—whole body | 6. Electric shock hazard                                    | 10. Crushing hazard—hand                             | 14. Do not move the traction unit while seated on the backhoe |
| 2. Keep bystanders away       | 7. Do not dig in areas with underground utilities           | 11. Keep hands and feet away from moving stabilizers | 15. Lower the stabilizers before beginning work               |
| 3. Safety alert symbol        | 8. Do not allow the backhoe to contact overhead power lines | 12. Secure the boom before leaving the machine       | 16. Use the counterweight                                     |
| 4. Read the operator's manual | 9. Crushing hazard—foot                                     | 13. Tipping hazard                                   |   |
| 5. Explosive hazard           |   |  |   |

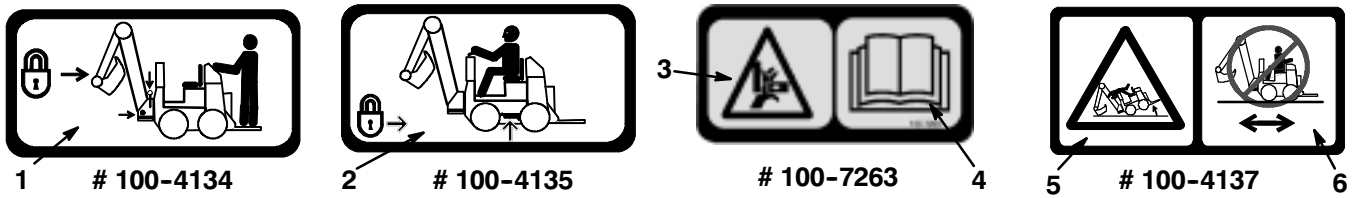

Figure 2

1. Secure the boom before transporting the backhoe
2. Install and secure the side bars before operating the backhoe
3. Crushing hazard
4. Read the operator's manual
5. Tipping hazard
6. Do not move the traction unit while seated on the backhoe

## Specifications

**Note:** Specifications and design are subject to change without notice.

Width	34.5 inches (87.6 cm)
Length	112.5 inches (286 cm)
Transport height	84 inches (213 cm)
Fully raised height	115 inches (292 cm)
Weight	710 lbs (322 Kg)
Digging depth (maximum)	79 inches (200.6 cm)
Bucket rotation	135 degrees
Swing arc	151 degrees
Stabilizer spread (working)	130 inches (330 cm)

## Stability Ratings

To determine the degree of slope you can traverse with the backhoe installed on a traction unit, find the stability rating for the hill position you want to travel in the following table, then find the degree of slope for the same rating and hill position in the Stability Data section of the traction unit operator's manual.

! **WARNING** !

**POTENTIAL HAZARD**

- Exceeding the maximum recommended slope can cause the traction unit to tip.

**WHAT CAN HAPPEN**

- If the traction unit tips, you or bystanders could be crushed.

**HOW TO AVOID THE HAZARD**

- Do not drive the traction unit on a slope steeper than the maximum recommended slope, as determined in the following table and the traction unit operator's manual.

Orientation	Stability Rating
<b>Front Uphill</b> 	C
<b>Rear Uphill</b> 	D
<b>Side Uphill</b> 	C

**IMPORTANT:** If your traction unit has a rear operator's platform, the counterweight must be used on the platform while using the backhoe, or the traction unit will become unstable.

# Setup

## Loose Parts

**Note:** Use the chart below to identify parts for assembly.

DESCRIPTION	QTY.	USE
Side bar bracket	2	Install the side bar brackets and attach to the backhoe.
Back-plate	2	
Bolt	6	
Nut	6	
Side bar, left	1	
Side bar, right	1	
Long tilt cylinder pin	1	
Cotter pin	2	
Lynch pin	2	
Link	2	
Bucket, 9, 12, or 16 inch (23, 30, or 41 cm)	1	Install on the backhoe. Must be purchased separately.

## Installing the Side Bar Bracket

1. Remove the traction unit manual holder and relocate it under the control panel (models 22305 and 22305TE only).
2. Remove the battery from the traction unit. Refer to your traction unit operator's manual.

**Note:** If you have a 4-Paw, diesel traction unit, you do not need to remove the battery; however, you do need to remove the loader arm cylinder and exhaust cover plate on the right side of the machine. To remove the loader arm cylinder, you need to raise the loader arms and install the cylinder lock on the left side before removing the right cylinder. Replace the cylinder and plate when finished installing the side bar bracket.

3. Line up the side bar bracket as illustrated in Figure 3 and mark the centers of the three holes (you may need to adjust the position of the bracket slightly so that the bracket and back-plate do not interfere with weldments on the traction unit).

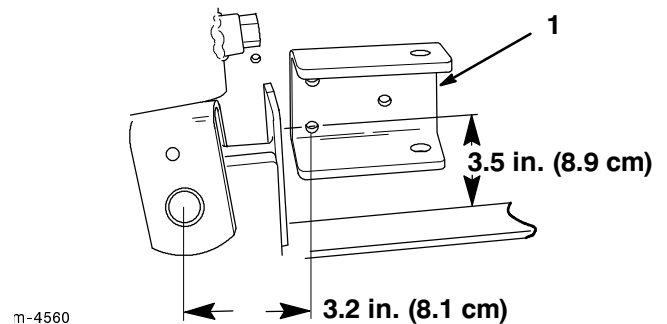

**Figure 3**

1. Side bar bracket
  2. 3.2 in. (8.1 cm)
- 
4. Drill three, 9/16 in. (1.43 cm) diameter holes through the side of the traction unit at the marked locations.
  5. Secure the side bar bracket to the side of the traction unit using the back-plate, three carriage bolts, and three nuts (Fig. 4).

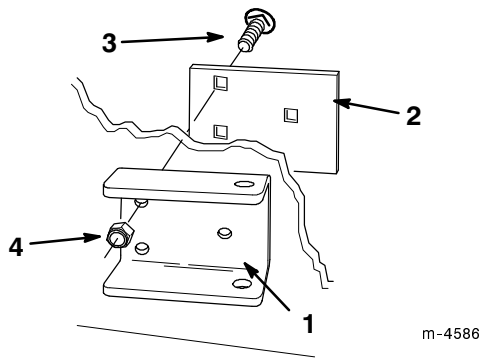

**Figure 4**

- |                     |                  |
|---------------------|------------------|
| 1. Side bar bracket | 3. Carriage bolt |
| 2. Back-plate       | 4. Nut           |

6. Torque the nuts to 75 ft-lbs (102 N·m).
7. Repeat steps 3-6 for the other side of the traction unit.
8. Install the battery from the traction unit. Refer to your traction unit operator's manual.

**Note:** On some chain drive traction units, the bolt heads will interfere with the battery case. If this happens, elongate the holes in the frame for mounting the battery clamp.

## Changing the Tilt Cylinder Pin

1. Block up the mount plate so that it cannot swing forward.

! **CAUTION** !

**POTENTIAL HAZARD**

- When you remove the tilt cylinder pin, the mount plate may swing forward.

**WHAT CAN HAPPEN**

- Your feet or hands, or those of bystanders, could be crushed.

**HOW TO AVOID THE HAZARD**

- Block up the mount plate before removing the tilt cylinder pin.

2. Remove the bolt securing the upper tilt cylinder pin (Fig. 5).
3. Using a hammer and punch, remove the tilt cylinder pin.

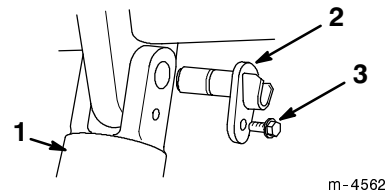
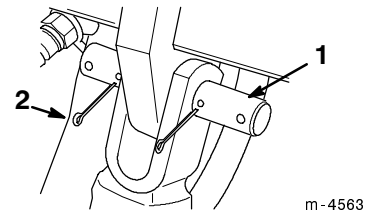

**Figure 5**

- |                      |         |
|----------------------|---------|
| 1. Tilt cylinder     | 3. Bolt |
| 2. Tilt cylinder pin |         |

4. Apply a generous coating of grease to the new pin.
5. Install the new pin into position and secure it with two cotter pins (Fig. 6).

**Note:** Leave the new pin installed, even when the backhoe is removed.



**Figure 6**

- |                          |               |
|--------------------------|---------------|
| 1. New tilt cylinder pin | 2. Cotter pin |
|--------------------------|---------------|

## Greasing the Backhoe

Before using the backhoe for the first time, ensure that all of the fittings are fully greased; refer to Greasing and Lubrication, page 14.

## Installing a Bucket

The backhoe does not come with a bucket installed because several sizes of buckets are available for you to choose from. Install your bucket as follows:

1. Connect the backhoe onto the traction unit and raise the dipperstick above the ground; for more information, refer to Operation, page 8.
2. Remove the bolts and nuts securing each of the two bucket pins to the dipperstick (Fig. 7).
3. Remove the pins.
4. Align the pin holes in the bucket with the mounting holes in the dipperstick (Fig. 7).

- Secure the bucket with the pins, bolts, and nuts removed previously (Fig. 7).

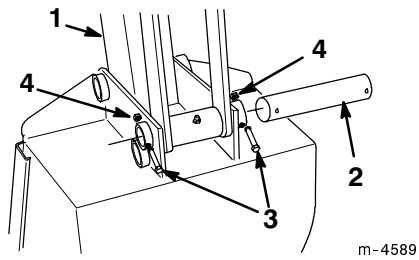

**Figure 7**

- |                |         |
|----------------|---------|
| 1. Dipperstick | 3. Bolt |
| 2. Bucket pin  | 4. Nut  |

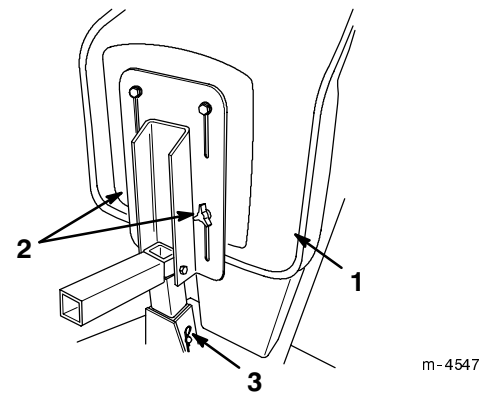

**Figure 8**

- |          |                           |
|----------|---------------------------|
| 1. Seat  | 3. Pin and hairpin cotter |
| 2. Knobs |                           |

## Adjusting the Seat

! **CAUTION** !

**POTENTIAL HAZARD**

- The seat mounting bracket has several pinch points.

**WHAT CAN HAPPEN**

- You could pinch and/or cut your fingers when adjusting the seat.

**HOW TO AVOID THE HAZARD**

- Take care to keep your fingers away from the seat mounting bracket when moving the seat up and down and when lowering the seat into position.

- Stop the engine.
- Tilt the seat forward.
- Loosen the knobs on the bottom of the seat (Fig. 8) and slide the seat forward or back as needed.
- To adjust the seat height, remove the hairpin cotter and pin from the seat stand (Fig. 8) and raise or lower the seat as required.

- When you have the proper height, install the pin and hairpin cotter to secure the seat.

# Operation

**Note:** Always use the traction unit to lift and move the attachment.

## Operation Checklist

To ensure safe, effective use of the backhoe, complete the following activities before, during, and after operating the backhoe:

**Note:** For detailed descriptions of these procedures, refer to *Installing the Backhoe on the Traction Unit* (page 9) and *Operating the Backhoe* (page 11).

### Before Operation:

- Locate and mark underground utilities.
- Install the counterweight on the traction unit.
- Install the links between the backhoe and the tilt cylinder pin on the traction unit.
- Install the side bars between the backhoe and the traction unit frame.
- Install the hydraulics lever clamp over the traction unit controls.
- Lower the stabilizer arms before digging.

### During Operation:

Only operate the backhoe from the backhoe seat.

Only move the traction unit from the traction unit operator's position and not from the seat of the backhoe.

### After Operation:

Install the pins securing the boom from moving up and down and side to side (Figs. 16 and 17) before leaving the backhoe unattended, transporting it, or disconnecting it from the traction unit.

## Backhoe Overview

Figure 9 illustrates the backhoe. Familiarize yourself with all of the components listed in Figure 9.

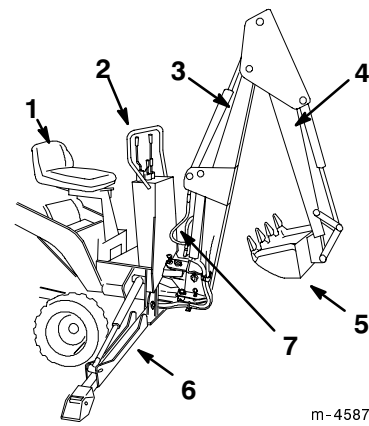
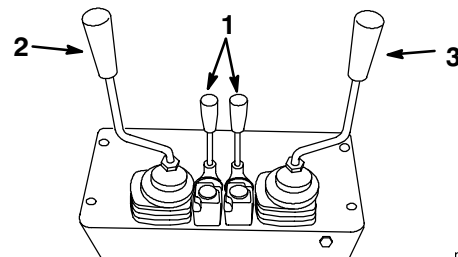

**Figure 9**

- |                |                           |
|----------------|---------------------------|
| 1. Seat        | 5. Bucket                 |
| 2. Controls    | 6. Stabilizer             |
| 3. Boom        | 7. Speed adjustment valve |
| 4. Dipperstick |                           |

## Controls

Familiarize yourself with all of the controls listed in Figure 10 before you operate the backhoe.



**Figure 10**

- |                              |                                     |
|------------------------------|-------------------------------------|
| 1. Stabilizer control levers | 3. Dipperstick/bucket control lever |
| 2. Boom control lever        |                                     |

### Stabilizer Control Levers

Move the stabilizer control levers forward to lower the stabilizers and rearward to raise the stabilizers.

### Boom Control Lever

Move the boom control lever forward to lower the boom and rearward to raise the boom. Move the boom control lever to the right to swing the boom to the right and move it left to swing the boom to the left.

You can also move the boom control lever into an intermediate position (i.e., forward and left, forward and right, rearward and left, or rearward and right) to swing the boom at the same time as you raise or lower it.

## Dipperstick/Bucket Control Lever

Move the dipperstick/bucket control lever forward to extend the dipperstick and rearward to retract the dipperstick. Move the dipperstick/bucket control lever to the right to dump the bucket and move it left to load the bucket.

You can also move the dipperstick/bucket control lever into an intermediate position (i.e., forward and left, forward and right, rearward and left, or rearward and right) to extend or retract the dipperstick at the same time as you load or dump the bucket.

## Connecting the Backhoe to the Traction Unit

**IMPORTANT:** Before connecting any attachments to the traction unit, ensure that the mount plates are free of any dirt or debris and that the pins rotate freely.

1. Start the engine.
2. Tilt the attachment mount plate forward.
3. Drive forward, positioning the mount plate into the upper lip of the receiver plate (Fig. 11).

**IMPORTANT:** You must center the mount plate in the receiver plate so that the gaps on the sides are equal. If you do not center the plates, you may not be able to install the side bars.

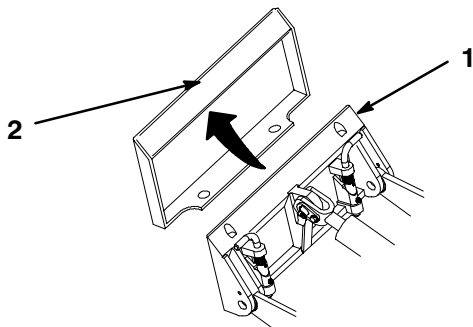

**Figure 11**

1. Mount plate
2. Receiver plate

4. Tilt the mount plate back until the receiver plate contacts the mount plate
5. Engage the quick attach pins, ensuring that they are fully seated in the mount plate (Fig. 12).

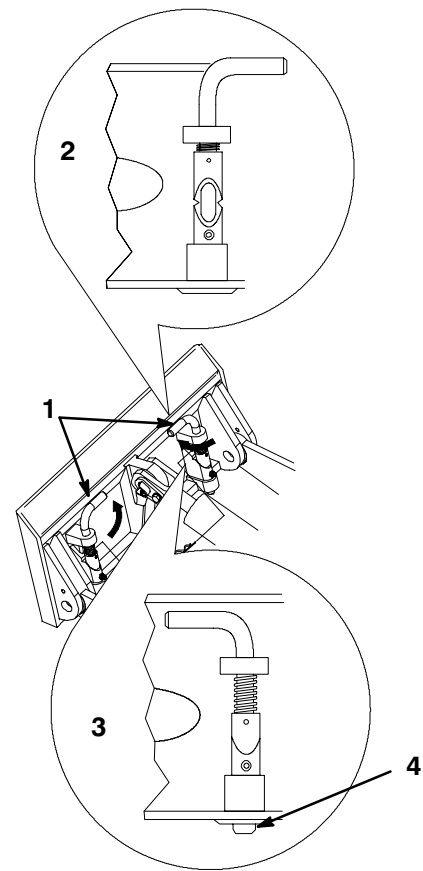

**Figure 12**

1. Quick attach pins (shown in engaged position)
2. Disengaged position
3. Engaged position
4. When engaged, the pin must protrude through the bottom of the attachment mount plate.

m-4056

! **WARNING** !

**POTENTIAL HAZARD**

- If the quick attach pins are not fully seated through the attachment mount plate, the attachment could fall off of the traction unit.

**WHAT CAN HAPPEN**

- Falling attachments can crush you or bystanders.

**HOW TO AVOID THE HAZARD**

- Always ensure that your quick attach pins are fully seated in the attachment mount plate.

6. Tilt the backhoe part of the way back.
7. Stop the engine.
8. Move the auxiliary hydraulics lever forward, backward, and back to neutral to relieve pressure at the hydraulic couplers.

9. Push the auxiliary hydraulics lever forward into the detent position.
10. Remove the protective covers from the hydraulic couplers on the traction unit.
11. Ensure that all foreign matter is cleaned from the hydraulic connectors.
12. Push the attachment male connector into the female connector on the traction unit.

**Note:** If you connect the attachment male connector first, you will relieve any pressure build up in the attachment.

**WARNING**

**POTENTIAL HAZARD**

- Hydraulic fluid escaping under pressure can penetrate skin and cause injury.

**WHAT CAN HAPPEN**

- Fluid accidentally injected into the skin must be surgically removed within a few hours by a doctor familiar with this form of injury or gangrene may result.

**HOW TO AVOID THE HAZARD**

- Keep body and hands away from pin hole leaks or nozzles that eject high pressure hydraulic fluid.
- Use cardboard or paper to find hydraulic leaks, never use your hands.

**CAUTION**

**POTENTIAL HAZARD**

- Hydraulic couplers, hydraulic lines/valves, and hydraulic fluid may be hot.

**WHAT CAN HAPPEN**

- Contact with hot hydraulic components or fluid may cause burns.

**HOW TO AVOID THE HAZARD**

- Wear gloves when operating the hydraulic couplers.
- Allow the traction unit to cool before touching hydraulic components.
- Do not touch hydraulic fluid spills.

13. Push the attachment female connector into the male connector on the traction unit.

14. Confirm that the connection is secure by pulling on the hoses.
15. Move the auxiliary hydraulics lever to neutral.
16. Start the engine.
17. Tilt the backhoe all the way back.

**CAUTION**

**POTENTIAL HAZARD**

- Tilting the backhoe can pinch hands.

**WHAT CAN HAPPEN**

- You could pinch and/or crush your hand when adjusting the seat.

**HOW TO AVOID THE HAZARD**

- Keep away from the moving backhoe when tilting.

18. Slide the two links on each end of the tilt cylinder pin and the backhoe link pin and secure them with two lynch pins (Fig. 13).

**Note:** You may need to move the attachment tilt lever to line up the holes in the links with the pins.

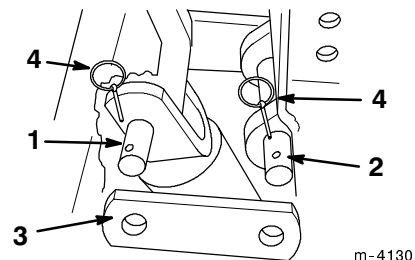
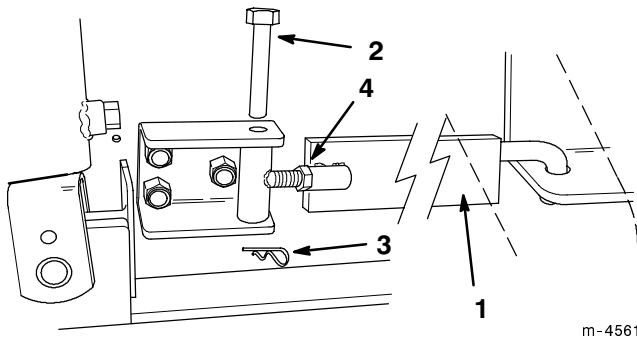

**Figure 13**

- |                      |              |
|----------------------|--------------|
| 1. Tilt cylinder pin | 3. Link      |
| 2. Backhoe link pin  | 4. Lynch pin |

19. Install the side bars on each side as illustrated in Figure 14. The decal on each side bar must be visible when installed.
20. If the bars do not fit snugly, remove them, loosen the jam nut, and thread the compound side bar together or apart as needed to ensure that they fit as tight as possible (Fig. 14). Tighten the jam nut when finished.

**Note:** If you have a 4-Paw, diesel traction unit, you may need to loosen the hood and slide it up in the mounting slots to ensure that the hood does not interfere with the side bars.

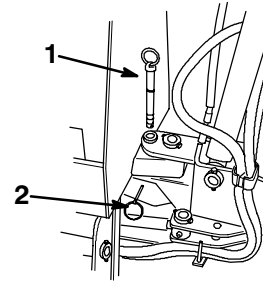

**Figure 14**

m-4561

- |             |                   |
|-------------|-------------------|
| 1. Side bar | 3. Hairpin cotter |
| 2. Pin      | 4. Jam nut        |

**Note:** One pin prevents the boom from swinging side to side (Fig. 16) and the other prevents the boom from moving up and down (Fig. 17).



**Figure 16**

m-4548

- |        |              |
|--------|--------------|
| 1. Pin | 2. Lynch pin |
|--------|--------------|

## Operating the Backhoe

### Preparing the Backhoe

1. Drive to the work location.
2. If your traction unit has a parking brake, engage it.
3. Pull the auxiliary hydraulics lever to the operator grip and install the hydraulics lever clamp by pushing it over the hand grip and sliding it right so that the pin through the clamp slides under the right hand grip (Fig. 15).

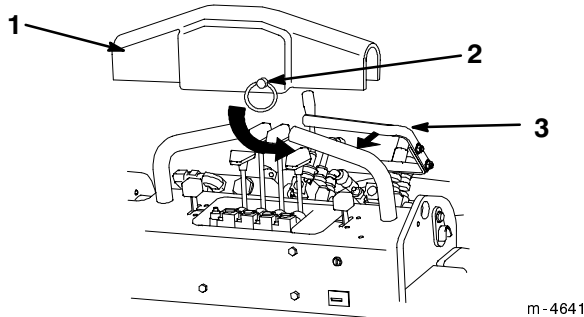

**Figure 15**

m-4641

- |                           |                               |
|---------------------------|-------------------------------|
| 1. Hydraulics lever clamp | 3. Auxiliary hydraulics lever |
| 2. Pin                    |                               |

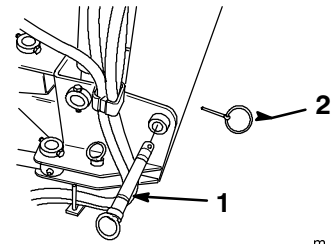

**Figure 17**

m-4550

- |        |              |
|--------|--------------|
| 1. Pin | 2. Lynch pin |
|--------|--------------|

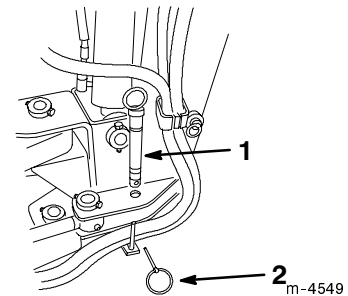

**Figure 18**

m-4549

- |        |              |
|--------|--------------|
| 1. Pin | 2. Lynch pin |
|--------|--------------|

4. Push the stabilizer control levers forward to lower both stabilizers until they touch the ground and the front wheels of the traction unit come off of the ground slightly.
5. Remove the two pins locking the boom in place (Figs. 16 and 17) and place them in the storage positions (Fig. 18).

### Digging a Hole

Using a backhoe with precision and proficiency takes time and practice. In general, you dig a hole by extending the dipperstick and bucket, lowering them into the ground, and then pullback on the dipperstick while raising the boom and curling the bucket rearward (Fig. 19).

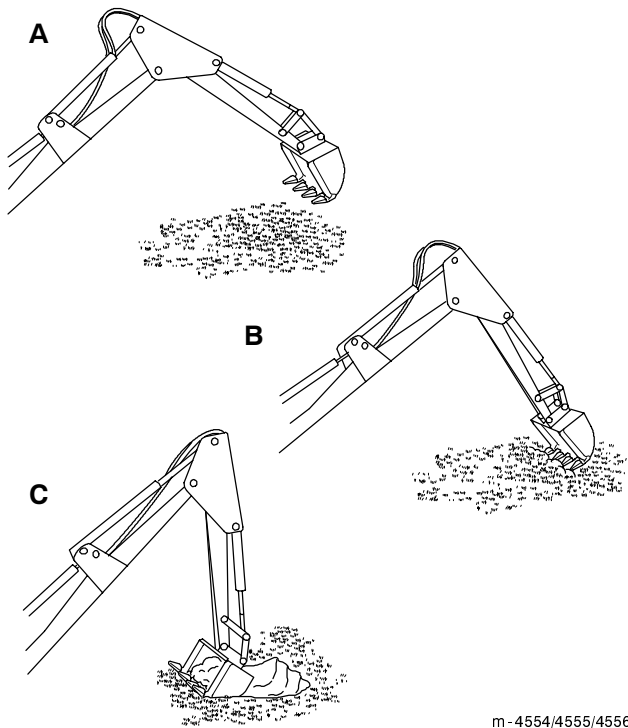

Figure 19

To empty the bucket you swing it to the left or right and extend the dipperstick and uncurl bucket, dumping the load (Fig. 20).

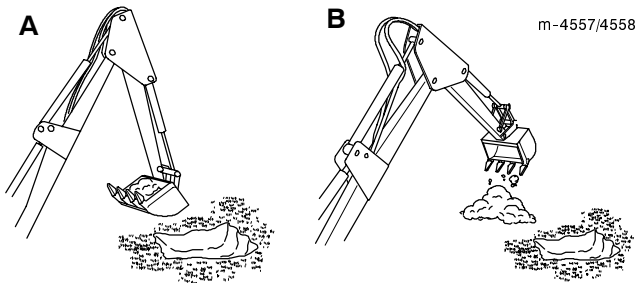

Figure 20

The distance you extend the dipperstick and bucket and the size of bite you take will vary greatly with the soil type, moisture content of the soil, and obstructions in the soil, such as tree roots and rocks.

Spend some time practicing with the backhoe to get the feel for how it operates and how to best use it in the conditions in which you work. Please read and use the following tips when operating the backhoe:

- Do not dig too close to the backhoe body or stabilizers. The backhoe could undercut the stabilizers or traction unit causing the machine to fall into the hole.

! **WARNING** !

**POTENTIAL HAZARD**

- If you dig too close to the backhoe, the backhoe could fall into the hole.

**WHAT CAN HAPPEN**

- The backhoe and traction unit could tip on top of you into the hole causing severe injury.

**HOW TO AVOID THE HAZARD**

- Ensure that you do not dig within three feet of the backhoe or stabilizers.

- Do not take large bites of soil. Instead, sweep the bucket through the soil using the swinging motion of the dipperstick a few inches deep at a time.
- If the bucket catches in the soil, uncurl the bucket, raise the boom slightly, and continue digging.
- If your traction unit has a speed selector, set it to the fast position (rabbit) while you are learning how to operate the backhoe (this will slow the backhoe down). Set it to the slow position (turtle) once you feel you have mastered the use of the backhoe.
- If your traction unit has a flow divider, set it to the 11 o'clock position.

## Securing the Backhoe for Transport

! **WARNING** !

**POTENTIAL HAZARD**

- If you do not secure the boom, it could swing or lower during transport or when disconnecting the backhoe from the traction unit.

**WHAT CAN HAPPEN**

- The traction unit could become unstable causing loss of control and you or bystanders could be injured.
- If the boom swings when disconnecting, it could crush or amputate fingers or hands as you or someone else disconnects the attachment locking pins.

**HOW TO AVOID THE HAZARD**

- Always secure the boom before transport and before disconnecting the backhoe from the traction unit.

1. Fully raise the boom, retract the dipperstick, and curl the bucket rearward (Fig. 21). Ensure that you center the boom locking pin holes as much as possible.

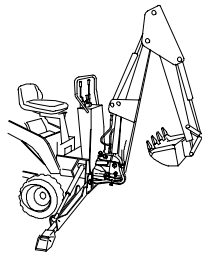

**Figure 21**

2. Pull the stabilizer levers rearward until the stabilizers are fully raised.
3. Secure the boom using the two pins removed prior to operation (Figs. 22 and 23).

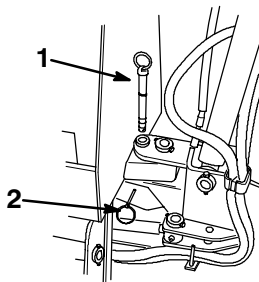

**Figure 22**

1. Pin
2. Lynch pin

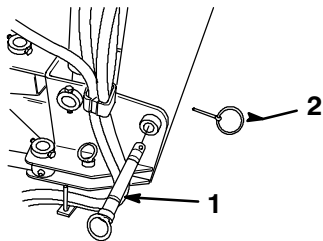

**Figure 23**

1. Pin
2. Lynch pin

4. Stop the engine and remove the key.
5. Remove the hydraulics lever clamp (Fig. 15).
6. Secure the clamp under the backhoe seat by inserting the end of the pin in the clamp into the hole in the seat support (Fig. 24).

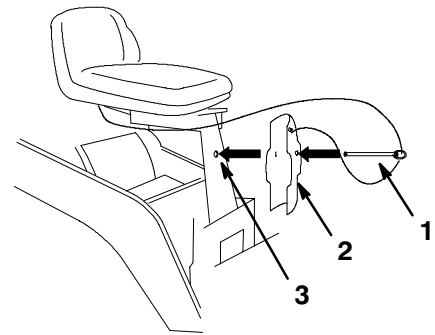

**Figure 24**

1. Pin
2. Clamp
3. Hole in seat support

7. Slowly transport the backhoe as needed.

## Disconnecting the Backhoe from the Traction Unit

1. Secure the backhoe in the transport position (refer to Securing for Transport, page 12), move the backhoe to a level storage area, and stop the engine.

⚠
WARNING
⚠

**POTENTIAL HAZARD**

- If you do not secure the boom, it could swing or lower when disconnecting the backhoe from the traction unit.

**WHAT CAN HAPPEN**

- The traction unit could become unstable causing loss of control and you or bystanders could be injured.
- If the boom swings when disconnecting, it could crush or amputate fingers or hands as you or someone else disconnects the attachment locking pins.

**HOW TO AVOID THE HAZARD**

- Always secure the boom before disconnecting the backhoe from the traction unit.

2. Remove the hairpin cotters and pins securing the side bars and remove the side bars (Fig. 14).
3. Pin the side bars in the storage positions as illustrated in Figure 25.

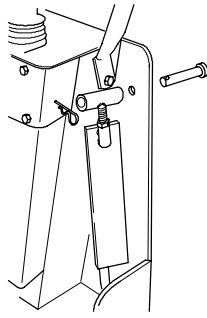

m-4590

Figure 25

4. Start the engine.
  5. Remove the lynch pins securing the links and remove the links (Fig. 13).
- Note:** You may need to adjust the tilt lever slightly to loosen the links.
6. Secure the links and two lynch pins for storage on the pins on the backhoe and the other two lynch pins on the traction unit tilt cylinder pin.
  7. Disengage the attachment lock pins by turning them to the outside.
  8. Tilt the backhoe forward slowly until the storage supports on the backhoe receiver plate and the bucket contacts the ground.

! **WARNING** !

**POTENTIAL HAZARD**

- If the backhoe is removed from the traction unit without a bucket installed on the dipperstick, the backhoe will be unstable.

**WHAT CAN HAPPEN**

- The backhoe could tip over injuring you or other bystanders.

**HOW TO AVOID THE HAZARD**

- Do not remove the backhoe from the traction unit without first installing a bucket onto the backhoe.

9. Stop the engine.
10. Move the auxiliary hydraulic lever forward, backward, and back to the neutral position to relieve hydraulic pressure at the hydraulic couplers.
11. Slide the collar back on hydraulic couplers and disconnect them.
12. Install protective covers onto the hydraulic couplers on the traction unit.

13. Start the engine.
14. Tilt the mount plate forward and back the traction unit away from the backhoe.

## Maintenance

! **CAUTION** !

**POTENTIAL HAZARD**

- If you leave the key in the ignition switch, someone could start the engine.

**WHAT CAN HAPPEN**

- Accidental starting of the engine could seriously injure you or other bystanders.

**HOW TO AVOID THE HAZARD**

- Remove the key from the ignition switch before you do any maintenance.

## Service Interval Chart

Service Operation	8 Hours	Storage Service
Grease fittings	X	X
Chipped surfaces-paint		X

## Greasing and Lubrication

### Service Interval/Specification

Grease all fittings every 8 operating hours (Fig. 26). Note that in most cases the grease fittings are located in the center of every pivot pin. Also, grease the fitting in the swing cylinder pivot pin, located under the seat column, under the backhoe (this location is not shown in Figure 26).

Grease all fittings immediately after every washing.

Grease Type: General-purpose grease

### How to Grease

1. Stop the engine and remove the key.
2. Clean the grease fittings with a rag.
3. Connect a grease gun to each fitting.
4. Pump grease into the fittings until grease begins to ooze out of the bearings.

5. Wipe up any excess grease.

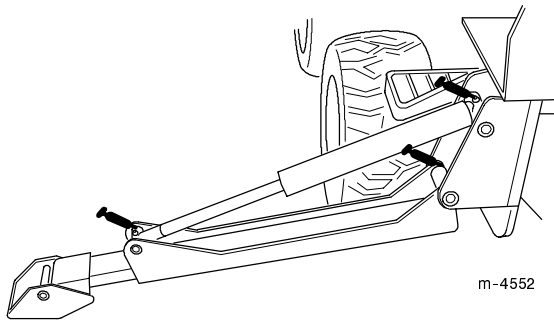
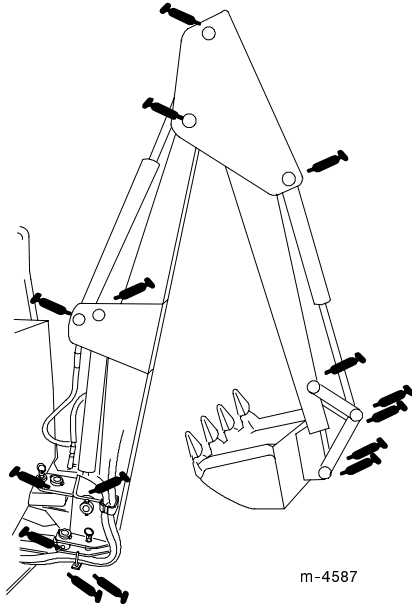

Figure 26

## Changing the Bucket Orientation

You can change the angle that the bucket is mounted on the dipperstick to a position that allows you to dig more vertically. This will allow you to dig very close to a foundation, or dig a square sided hole. To change the orientation, complete the following procedure:

1. Remove the bolts and nuts securing the upper bucket pin (Fig. 27).
2. Remove the pin.
3. Swing the bucket up, aligning the second set of holes with the mounting holes on the dipperstick (Fig. 27).

4. Secure the bucket with the pin, bolt, and nut removed previously.

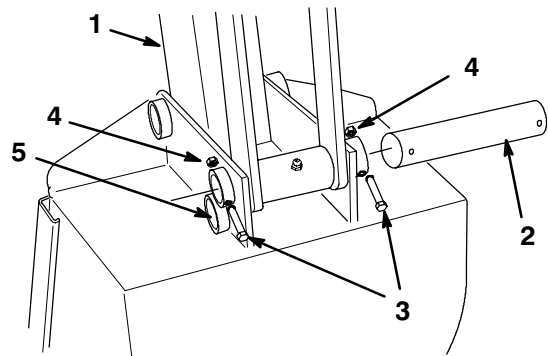

Figure 27

- |                     |                        |
|---------------------|------------------------|
| 1. Dipperstick      | 4. Nut                 |
| 2. Upper bucket pin | 5. Second set of holes |
| 3. Bolt             |                        |

## Changing the Boom Speed

You can change the speed that the boom moves up and down and left and right by changing the setting of three speed adjustment valves. The valve that controls the up and down movement is located on top of the boom (Fig. 9).

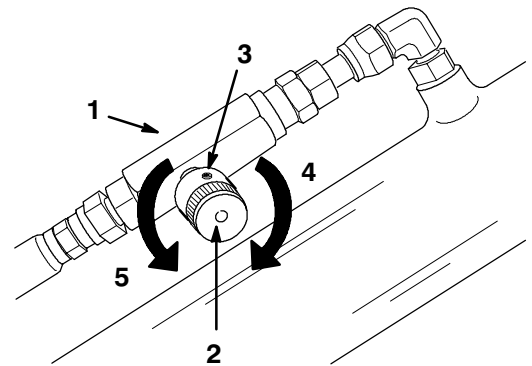
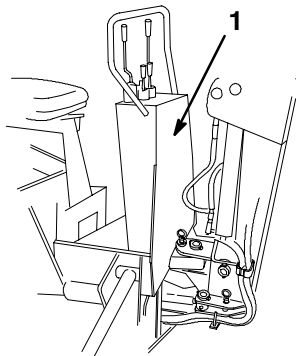

Figure 28

- |                           |         |
|---------------------------|---------|
| 1. Speed adjustment valve | 4. Slow |
| 2. Knob                   | 5. Fast |
| 3. Set screw              |         |

The two valves that control the left and right swing of the boom are located inside of the controls access panel (Fig. 29). To access these valves, remove six locknuts and the panel. Adjust both valves equally. Replace the access panel when finished.



m-4587

**Figure 29**

1. Controls access panel

To adjust the valves, complete the following procedure and refer to Figure 28.

1. Loosen the set screw located on the side of the knob on the valve.
2. To increase the speed of the boom, turn the knob counter-clockwise.
3. To decrease the speed of the boom, turn the knob clockwise.
4. Tighten the set screw.

## Storage

1. Before long term storage wash the attachment with mild detergent and water to remove dirt and grime.
2. Apply grease to all grease fittings.
3. Check and tighten all bolts, nuts, and screws. Repair or replace any part that are damaged or worn.
4. Paint all scratched or bare metal surfaces. Paint is available from your Authorized Service Dealer.
5. Store the attachment in a clean, dry garage or storage area. Cover it to protect it and keep it clean.

# Troubleshooting

PROBLEM	POSSIBLE CAUSES	CORRECTIVE ACTION
Backhoe does not operate	<ol style="list-style-type: none"> <li>1. Hydraulic coupler not completely connected</li> <li>2. Auxiliary hydraulics valve on the traction unit is not fully engaged.</li> <li>3. Transport pins were not removed.</li> <li>4. Hydraulic fluid level is low.</li> <li>5. Damaged hydraulic coupler</li> <li>6. Obstructed hydraulic hose</li> <li>7. Pinched hydraulic hose</li> <li>8. Auxiliary hydraulic valve on the traction unit is not opening.</li> <li>9. Hydraulic coupler not completely connected</li> <li>10. Bent piston rod</li> </ol>	<ol style="list-style-type: none"> <li>1. Check and tighten all couplers.</li> <li>2. Engage the valve.</li> <li>3. Remove the pins.</li> <li>4. Fill the traction unit hydraulic tank.</li> <li>5. Check couplers and replace any that are defective.</li> <li>6. Find and remove the obstruction.</li> <li>7. Replace the hose.</li> <li>8. Repair the valve.</li> <li>9. Check and tighten all couplers.</li> <li>10. Contact your Authorized Toro Dealer.</li> </ol>

<b>PROBLEM</b>	<b>POSSIBLE CAUSES</b>	<b>CORRECTIVE ACTION</b>
Backhoe is operating slowly	<ol style="list-style-type: none"> <li>1. Hydraulic oil is cold.</li> <li>2. Engine speed is too slow.</li> <li>3. Speed adjustment valve is set too slow.</li> <li>4. Pinched hydraulic hose</li> <li>5. Speed adjustment valve is leaking oil.</li> <li>6. Damaged cylinder</li> <li>7. Damaged hydraulic pump</li> </ol>	<ol style="list-style-type: none"> <li>1. Allow the engine to warm the oil before operating.</li> <li>2. Increase the throttle speed of the traction unit.</li> <li>3. Adjust the speed adjustment valve to obtain the desired speed.</li> <li>4. Replace the hose.</li> <li>5. Contact your Authorized Toro Dealer.</li> <li>6. Contact your Authorized Toro Dealer.</li> <li>7. Contact your Authorized Toro Dealer.</li> </ol>
Backhoe fails to hold up a load (all loads will normally settle down over a long period of time)	<ol style="list-style-type: none"> <li>1. Damaged hydraulic hose</li> <li>2. Damaged cylinder</li> <li>3. Damaged control valve</li> </ol>	<ol style="list-style-type: none"> <li>1. Replace the hose.</li> <li>2. Contact your Authorized Toro Dealer.</li> <li>3. Contact your Authorized Toro Dealer.</li> </ol>
Hydraulic oil leakage	<ol style="list-style-type: none"> <li>1. Damaged hydraulic hose</li> <li>2. Damaged hydraulic system</li> </ol>	<ol style="list-style-type: none"> <li>1. Replace the hose.</li> <li>2. Contact your Authorized Toro Dealer.</li> </ol>
Swing cylinder malfunctioning	<ol style="list-style-type: none"> <li>1. Damaged cylinders, swing restrictors, or cross-over relief valve</li> </ol>	<ol style="list-style-type: none"> <li>1. Contact your Authorized Toro Dealer.</li> </ol>
Control valve sticking or working hard	<ol style="list-style-type: none"> <li>1. Dirty hydraulic oil</li> <li>2. Damaged or dirty valve</li> <li>3. Damaged cylinder</li> </ol>	<ol style="list-style-type: none"> <li>1. Change the hydraulic oil.</li> <li>2. Contact your Authorized Toro Dealer.</li> <li>3. Contact your Authorized Toro Dealer.</li> </ol>
Backhoe operation is spongy or jerky	<ol style="list-style-type: none"> <li>1. Hydraulic fluid level is low.</li> <li>2. Air in the hydraulic system</li> <li>3. Hydraulic oil is cold.</li> <li>4. Pinched hydraulic hose</li> </ol>	<ol style="list-style-type: none"> <li>1. Fill the traction unit hydraulic tank.</li> <li>2. Extend the cylinders as far as possible and hold them in an extended position for several seconds.</li> <li>3. Allow the engine to warm the oil before operating.</li> <li>4. Replace the hose.</li> </ol>





