



Blower Assembly Kit

Wheelhorse® 44" Vacuum Baggers

Part No. 104-2489

Installation Instructions

Remove the Discharge Tube

1. Unhook the rubber latch from the knob (Fig. 1).
2. Slide the lower end of the discharge tube off the blower discharge opening (Fig. 1).

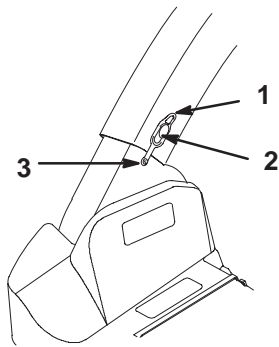

Figure 1

1. Rubber latch
2. Knob
3. Latch post

3. Remove the rubber latch, latch post, and push fastener securing the latch post from the blower, saving them for later (Fig. 1).

Note: Removing the latch post fastener may damage the fastener. You can order another fastener from your Authorized Toro Dealer.

Remove Blower Belt Cover

Remove the 2 knobs and 4 washers securing the blower belt cover and remove the cover (Fig. 2).

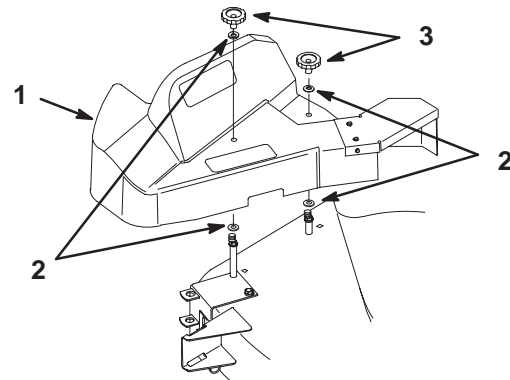

m-3590

Figure 2

1. Blower belt cover
2. Washer
3. Knob

Remove the Blower from the Mower

1. Open the latch and swing the blower out away from the mower (Fig. 3).

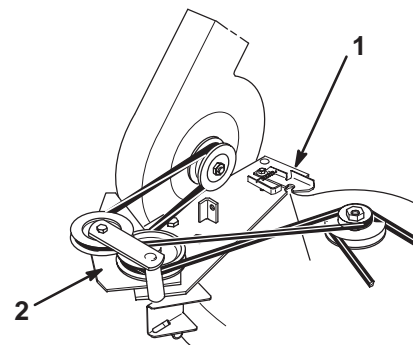

m-3557

Figure 3

1. Latch
2. Pulleys

- Remove the blower belt from idler and blower pulleys (Fig. 3).
- Remove the blower by lifting the pivot pin out of the pivot support (Fig. 4).

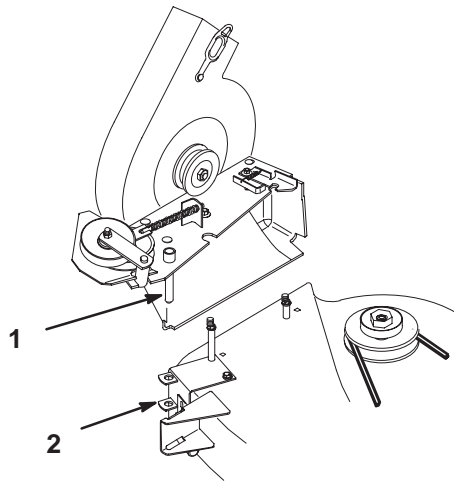

m-3593

Figure 4

- Pivot pin
- Pivot support

Removing the Latch and Blower Mounting Plate

- Remove the bolt, washer, and nut securing the latch to the top of the blower (Fig. 5).

Note: You can leave the latch connected to the blower mounting plate by the spring if desired.

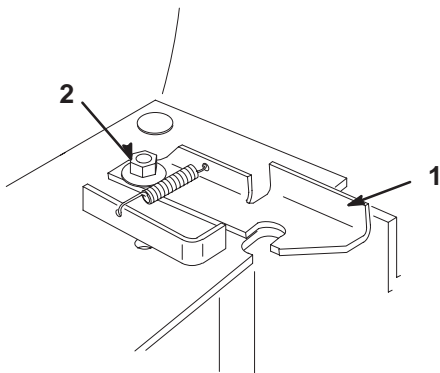

Figure 5

- Latch
- Bolt, nut, and washer

- Remove the flange nut, washer, and carriage bolt securing the L-bracket and remove the bracket.
- Remove the 3 carriage bolts and flange nuts securing the blower mounting plate to the blower and remove the plate.

- Save the blower mounting plate, latch, and all removed hardware, and discard the blower

Assembling the New Blower

- Assemble the blower mounting plate to the new blower (Fig. 6) with 3 carriage bolts and flange nuts.

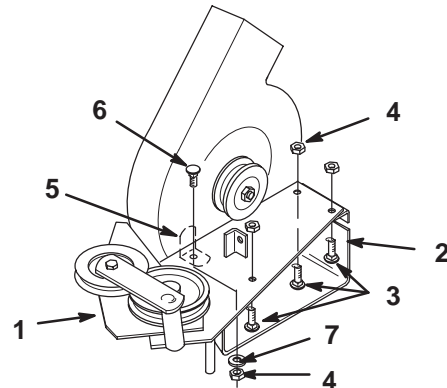

1495

Figure 6

- Blower mounting plate
- Blower assembly
- Carriage bolt, 5/16 x 3/4 in.
- Flange nut, 5/16 in.
- L-bracket
- Carriage bolt, 5/16 x 7/8 in. (down from top)
- Washer, 5/16 in.

- In the front inside hole of the blower insert a carriage bolt (Fig. 6).

Important The carriage bolt must be installed down through the plate and blower for proper belt clearance.

- Inside the blower housing, slide the L-bracket over the bolt.
- Hold the L-bracket tight against the blower housing wall and secure it with the washer and flange nut (Fig. 6).

- Install the latch using the bolt, washer, and nut removed previously (Fig. 5).

Important Ensure that you do not over tighten the bolt and nut securing the latch. The latch must be able to pivot freely.

- If you disconnected the latch spring, connect it to the bracket on the blower mounting plate.
- Install the bolt, latch post, and rubber latch on the new blower (Fig. 1).

Installing the Blower

Install the blower onto your mower as directed in your *Blower Operator's Manual*.