



Count on it.

Parts Catalog

**21in Heavy-Duty Recycler®/Rear
Bagger**

Lawn Mower

Model No. 22287—Serial No. 40000000 and Up



Ordering Replacement Parts

To order replacement parts, please supply the part number, the quantity, and the description of each part desired.

Understanding Reference Numbers

Each identified part in an illustration has a reference number. The reference number for a part also appears in the parts list, along with other information about the part.

This catalog uses two special reference number formats, one to indicate parts in a service assembly and another to indicate the quantity of a given part in an illustration.

Service Assembly Reference Numbers

Parts in service assemblies have reference numbers in the form a:b. The a represents the reference number of the entire service assembly and the b represents a sequential number unique to each part within the service assembly.

For example, a wheel assembly might be identified by reference number 6, the tire by 6:1, the valve by 6:2, and the wheel by 6:3. When you order the assembly identified by reference number 6, you receive all parts identified by reference numbers 6:1, 6:2, and 6:3. However, you may also order any part individually. Reference numbers of this type appear in illustration and in parts lists.

Reference Numbers Indicating Quantity

In an illustration, if a reference number indicates more than one part, the reference number has the form nX y. The n represents the quantity of the part, the X is the multiplication symbol, and the y represents the reference number.

For example, in an illustration, the reference number 2X 37 means that two of the parts identified by reference number 37 are indicated.

Contents

Housing Assembly	4
Grass Bag Assembly	6
Engine and Blade Assembly	8
Front Wheel and Height-of-Cut Assembly	10
Transmission and Rear Wheel Assembly	12
Handle and Control Assembly	14
Attachments and Accessories	16

Housing Assembly

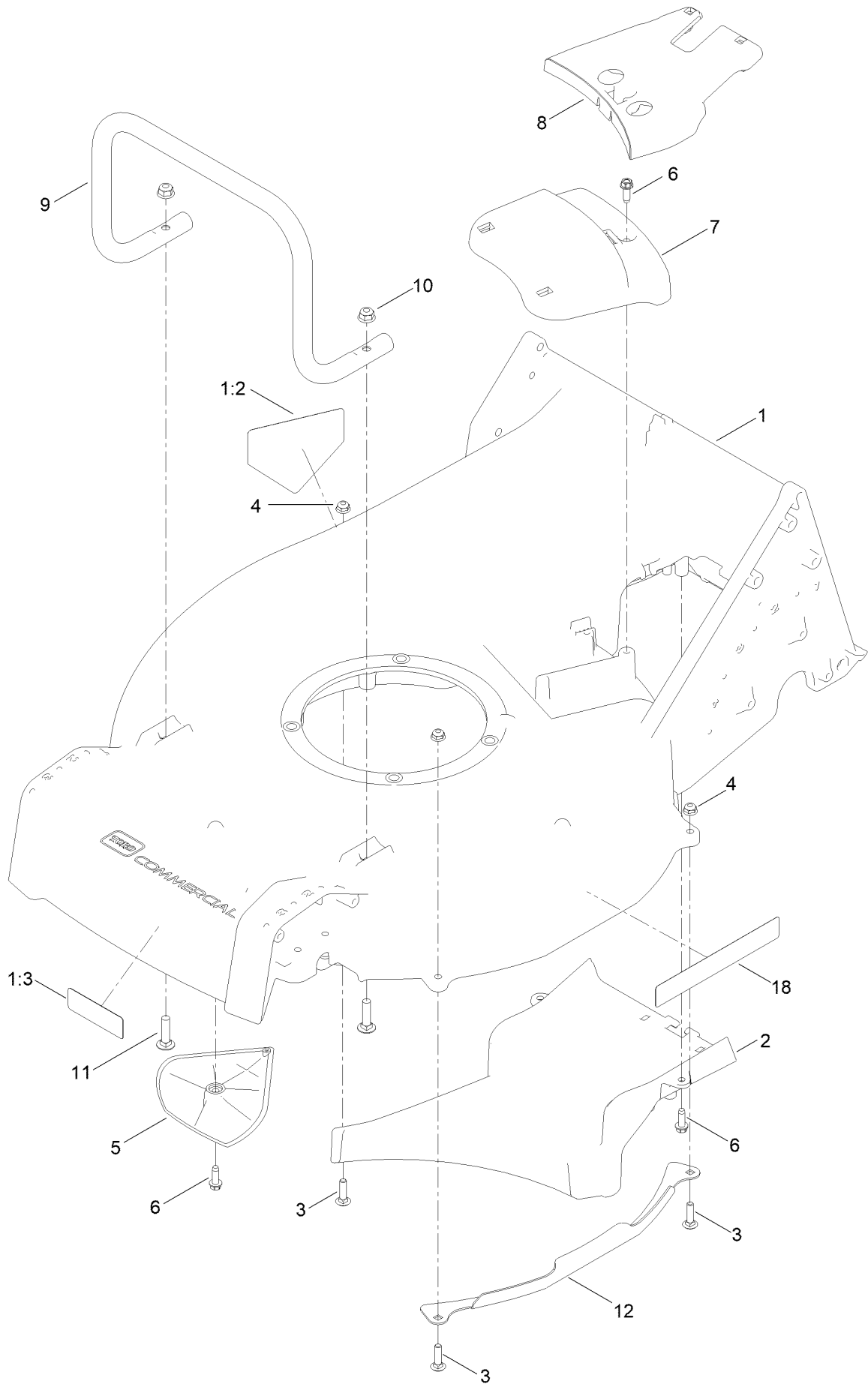

Housing Assembly (continued)

<i>Ref.</i>	<i>Part Number</i>	<i>Qty.</i>	<i>Description</i>	<i>Ref.</i>	<i>Part Number</i>	<i>Qty.</i>	<i>Description</i>
1	136-5896	1	Housing ASM	7	125-5038	1	Cover-Belt, Front
1:2	94-8072	1	Decal-Danger	8	125-8380	1	Cover-Belt, Rear
1:3	130-9670	1	Decal-Warning, Blade	9	140-3880-03	1	Guard-Engine
2	125-1002-01	1	Floor-Chute	10	104-8300	2	Nut-HF, NI
3	3229-2	4	Screw-CARR	11	3230-3	2	Screw-CARR
4	104-7201	4	Nut-HF	12	125-1047-03	2	Guard-Side, Deck
5	125-5041	2	Kicker	18	119-2368	2	Decal-Recycler
6	49-2040	5	Screw-HWHTF				

Grass Bag Assembly

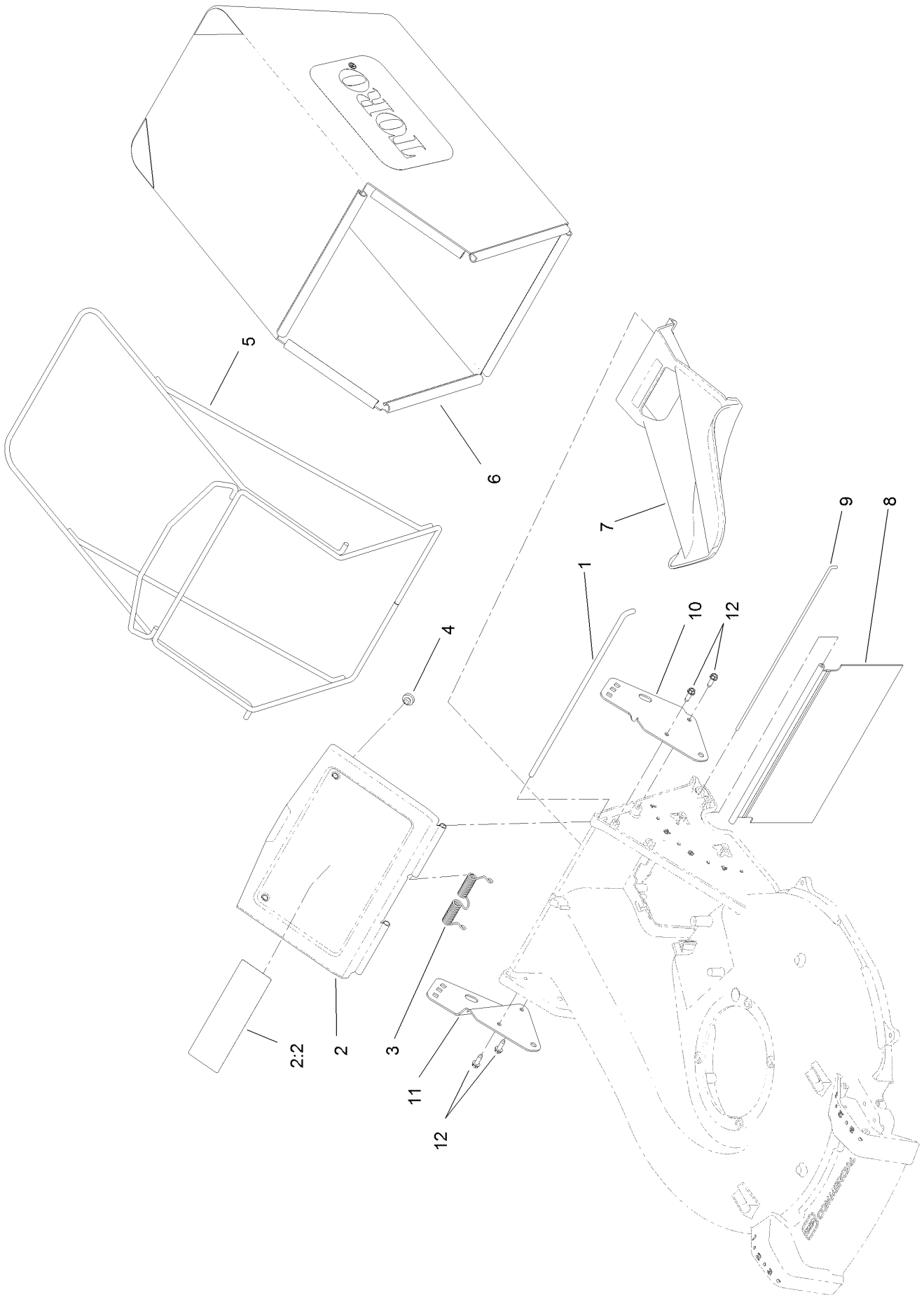

Grass Bag Assembly (continued)

<i>Ref.</i>	<i>Part Number</i>	<i>Qty.</i>	<i>Description</i>	<i>Ref.</i>	<i>Part Number</i>	<i>Qty.</i>	<i>Description</i>
1	125-1017	1	Rod-Door, Bag	7	125-1008	1	Plug-Mulch
2	125-8402	1	Bag Door ASM	8	125-1007	1	Shield-Trailing
2:2	116-7583	1	Decal-Warning	9	125-8413	1	Rod-Shield, Trailing
3	125-1019	1	Spring-Torsion	10	133-8193-03	1	Bracket-Mount, Handle (LH)
4	1-513658	2	Bumper	11	133-8194-03	1	Bracket-Mount, Handle (RH)
5	121-1399-03	1	Frame-Bag	12	32144-70	4	Screw-HWHTF
6	125-1030	1	Bag-Grass				

Engine and Blade Assembly

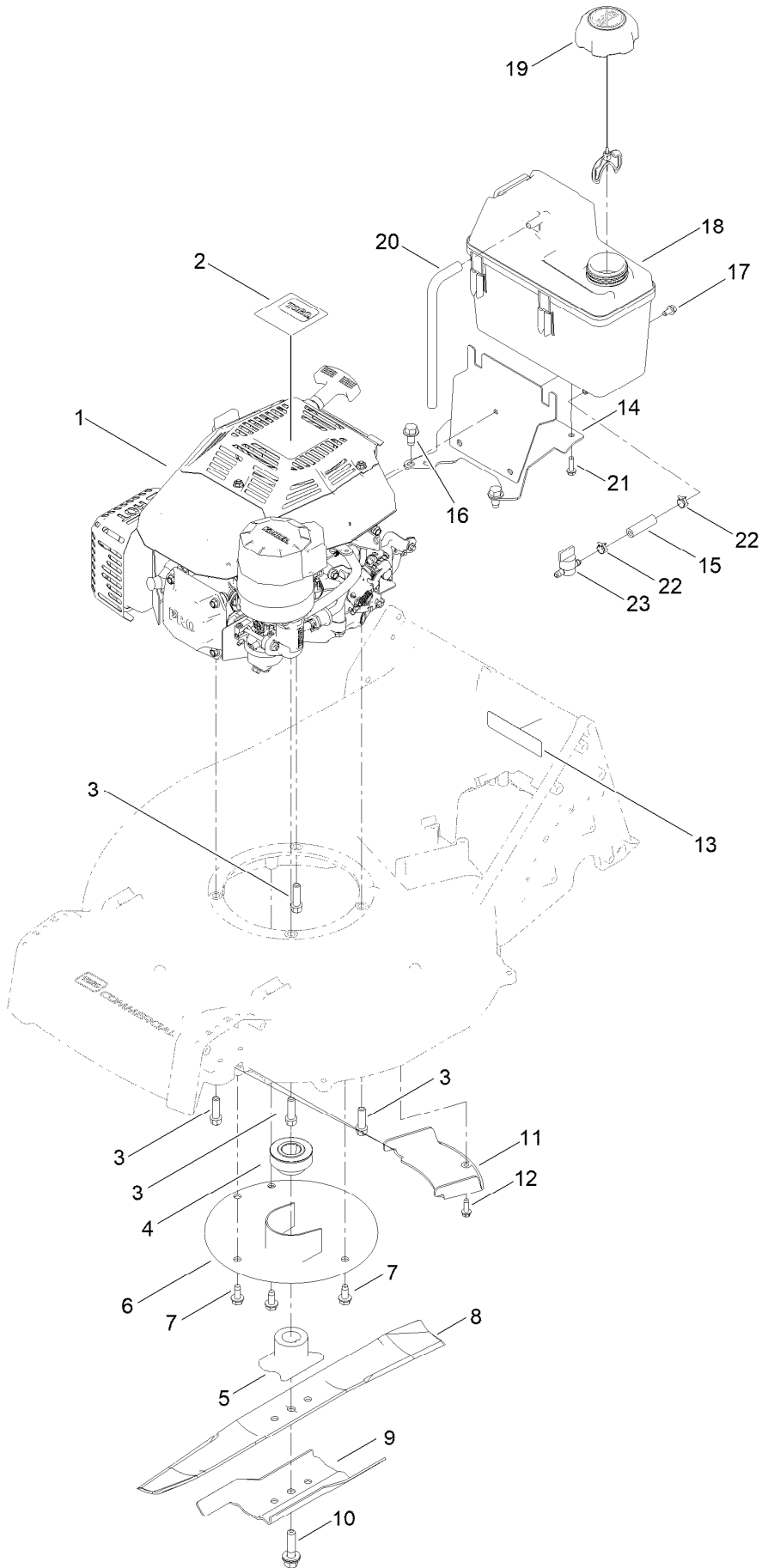

Engine and Blade Assembly (continued)

<i>Ref.</i>	<i>Part Number</i>	<i>Qty.</i>	<i>Description</i>	<i>Ref.</i>	<i>Part Number</i>	<i>Qty.</i>	<i>Description</i>
1		1	Engine-Kohler ●■	13	133-8062	1	Decal-Arrestor, Spark
2	140-4116	1	Decal-Kohler	14	133-8173	1	Tank Mount ASM
3	95-1727	4	Screw-Taptite	15	119-7856	1	Hose-Fuel
4	125-8396	1	Pulley-Driver	16	110-9380	2	Screw-HWH
5	125-1004	1	Driver-Blade	17	116-8929	1	Screw-HWH
6	125-8370	1	Protector-Crankshaft	18	114-0280	1	Tank-Fuel
7	32144-70	3	Screw-HWHTF	19	137-4127	1	Cap-Fuel
8	133-8183-03	1	Blade-Recycling, 21In	20	115-0962	1	Hose-Vent, Canister
9	125-1069-03	1	Accelerator-Blade	21	46-8091	2	Screw-HWH
10	125-2466	1	Bolt-Blade	22	2412-98	2	Clamp-Hose
11	125-1024	1	Cover-Belt	23	1-603770	1	Valve-Fuel
12	49-2040	1	Screw-HWHTF				

● Not serviced separately

■ Obtain parts from www.kohlerplus.com

Front Wheel and Height-of-Cut Assembly

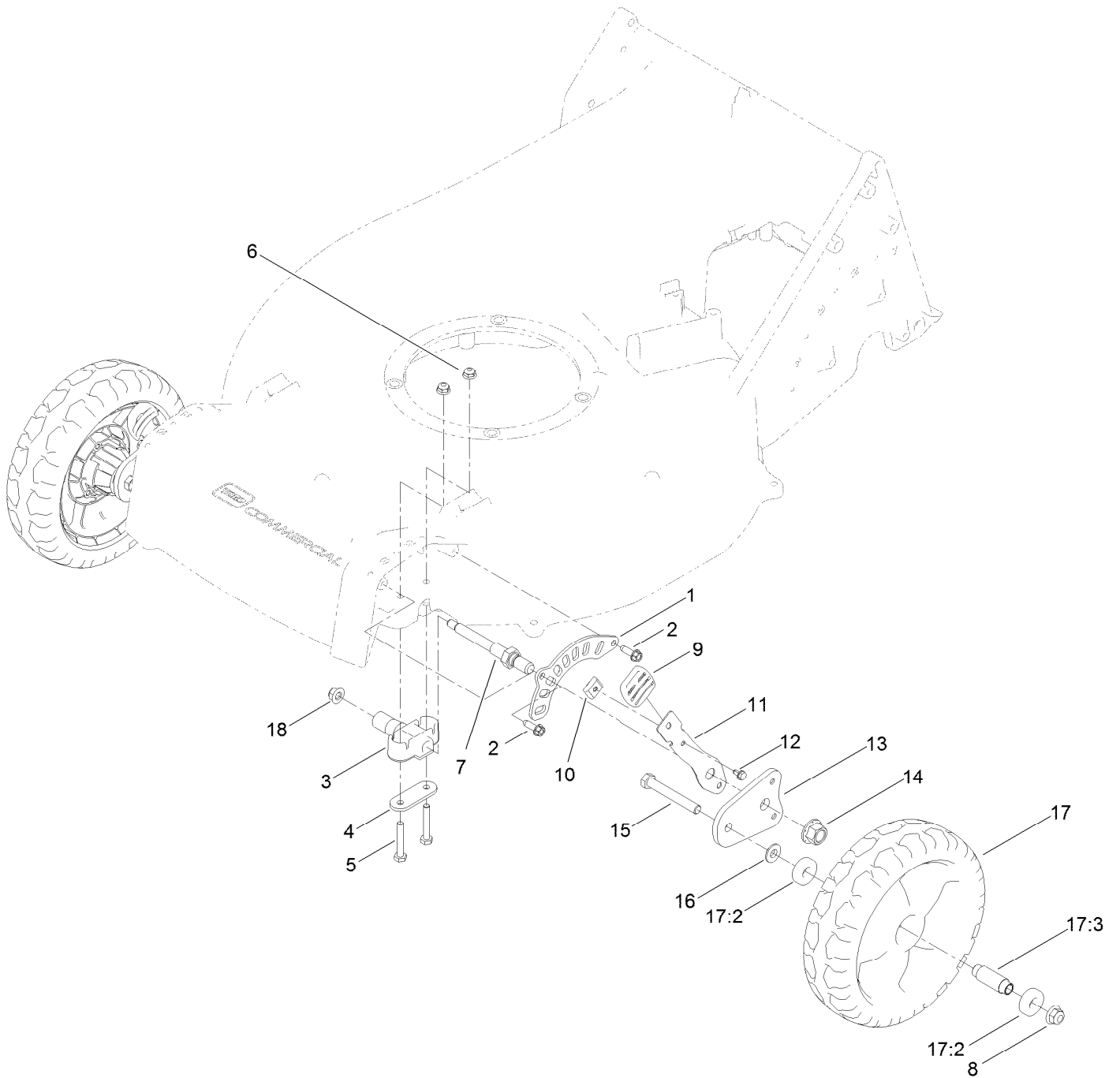

Front Wheel and Height-of-Cut Assembly (continued)

<i>Ref.</i>	<i>Part Number</i>	<i>Qty.</i>	<i>Description</i>	<i>Ref.</i>	<i>Part Number</i>	<i>Qty.</i>	<i>Description</i>
1	121-1439	2	Plate-HOC, Front	11	121-1431-03	2	Arm-Spring
2	49-2040	4	Screw-HWHTF	12	104-2065	2	Screw-HWH
3	136-5871	2	Bushing-Axle, Front (HOC)	13	130-6420	2	Arm-Pivot, Front
4	130-6434	2	Retainer-Bushing, Axle	14	99-5107	2	Nut-Lock
5	321-37	4	Screw-HH	15	323-13	2	Screw-HH
6	104-7201	4	Nut-HF	16	74-1671	2	Spacer-Cover, Wheel
7	133-2644	2	Axle-Front HOC	17	133-2639	2	Wheel
8	104-8301	2	Nut-HF, NI	17:2	133-2603	2	Bearing-Ball
9	125-1093	2	Knob-Lever, HOC	17:3	125-1077	1	Spacer
10	131-5377	2	Key-Arm, Spring	18	104-8300	2	Nut-HF, NI

Transmission and Rear Wheel Assembly

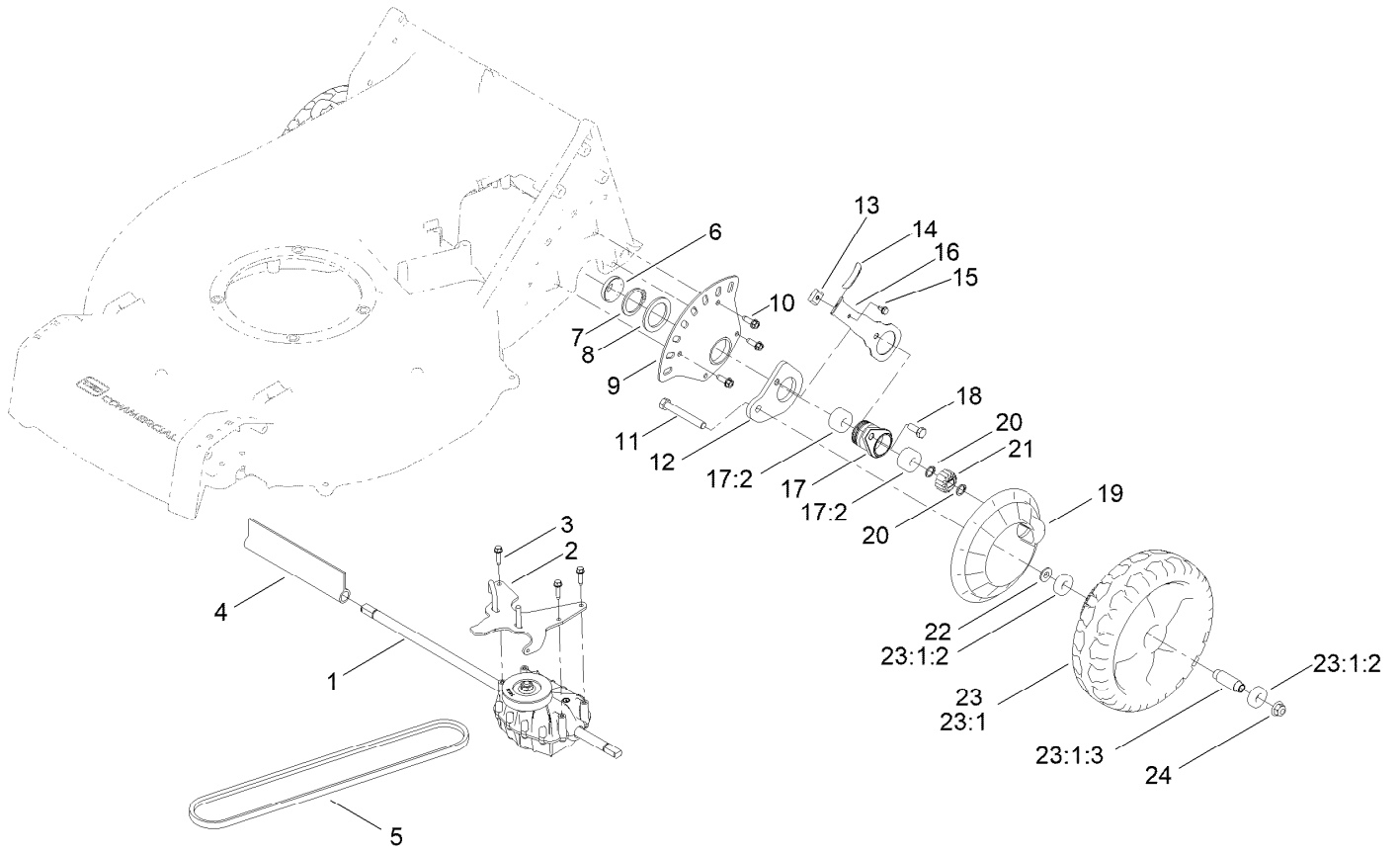

Transmission and Rear Wheel Assembly (continued)

<i>Ref.</i>	<i>Part Number</i>	<i>Qty.</i>	<i>Description</i>	<i>Ref.</i>	<i>Part Number</i>	<i>Qty.</i>	<i>Description</i>
1	140-4011	1	Transmission-HD	15	104-2065	2	Screw-HWH
2	140-4012-03	1	Belt Guide ASM	16	121-1448-03	2	Arm-Spring, Rear
3	27-0220	3	Screw-Special	17	136-5894	2	Bearing Retainer ASM
4	130-9681	1	Cover-Shaft, Transmission	17:2	133-2606	2	Bearing-Ball, Custom
5	125-8395	1	Belt-V	18	133-2668	2	Screw-HH
6	127-6848	2	Cover-Bearing	19	133-2635	2	Cover-Wheel
7	32151-10	2	Ring-Retaining	20	32151-61	4	Ring-Retaining
8	98-1452	2	Washer-Thrust	21	131-5399	2	Gear-Pinion, 15T
9	130-6422	2	Plate-HOC, Rear	22	74-1671	2	Spacer-Cover, Wheel
10	49-2040	6	Screw-HWHTF	23	133-2640	2	9-Inch Wheel ASM
11	323-13	2	Screw-HH	23:1		1	Wheel ●
12	133-2641	2	Arm-Pivot, Rear	23:1:2	133-2603	2	Bearing-Ball
13	131-5377	2	Key-Arm, Spring	23:1:3	125-1077	1	Spacer
14	125-1093	2	Knob-Lever, HOC	24	104-8301	2	Nut-HF, NI

● Not serviced separately

Handle and Control Assembly

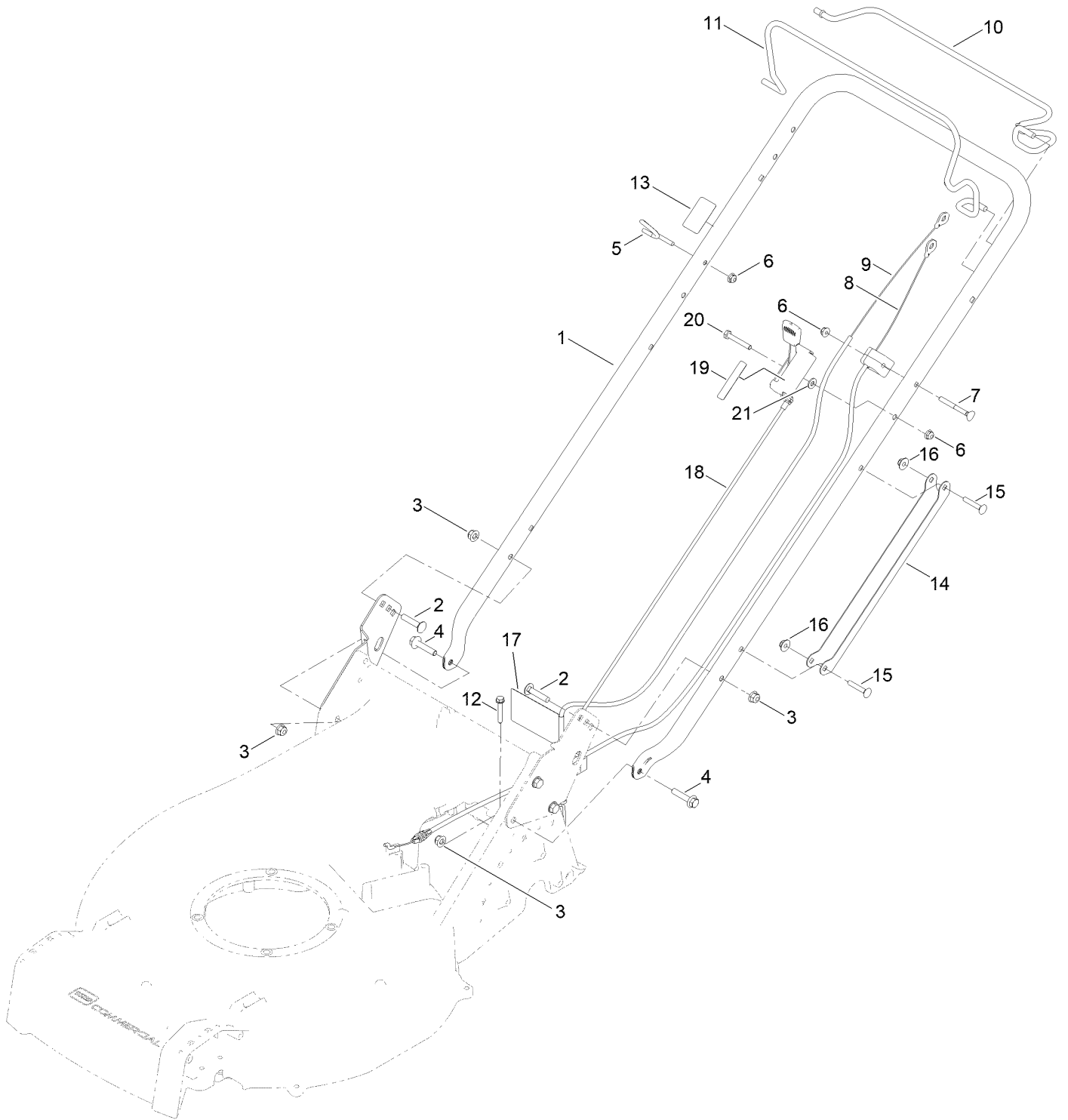

Handle and Control Assembly (continued)

<i>Ref.</i>	<i>Part Number</i>	<i>Qty.</i>	<i>Description</i>	<i>Ref.</i>	<i>Part Number</i>	<i>Qty.</i>	<i>Description</i>
1	137-4817-03	1	Handle	12	94-2691	1	Screw-HWH
2	3230-4	2	Bolt-CARR	13	125-8404	1	Decal-Primer
3	104-8300	4	Nut-HF, NI	14	127-6897-03	1	Guard-Cable, Handle
4	115-1794	2	Screw-HHF	15	108-0988	2	Screw-CARR
5	114-2775	1	Guide-Rope	16	114-3778	2	Nut-HF
6	104-7201	3	Nut-HF	17	130-6722	1	Decal
7	92-2270	1	Screw-Handle	18	139-1821	1	Control-Throttle
8	140-3884	1	Cable-Brake, Kohler	19	125-8406	1	Decal-Throttle, Choke
9	125-8372	1	Cable-Traction	20	321-10	1	Screw-HH
10	125-8437-03	1	Bail-Traction	21	3256-22	1	Washer-Flat
11	125-8436-03	1	Bail-Brake				

Attachments and Accessories

For 22287 21in Heavy-Duty Recycler/Rear Bagger Lawn Mower

Product Name	Model/Part
Blade-Bagging, 21in	125-1072-03
Cup-Anti Scalp.....	125-8440
Rear Discharge Kit.....	130-9734

Notes:

Notes:

Notes:



Count on it.