



Count on it.

Operator's Manual

**60in and 72in DFS E-Z Vac™
Collection System
Z500 Series Z Master® Mowers**

Model No. 78544—Serial No. 280000001 and Up

Model No. 78545—Serial No. 280000001 and Up

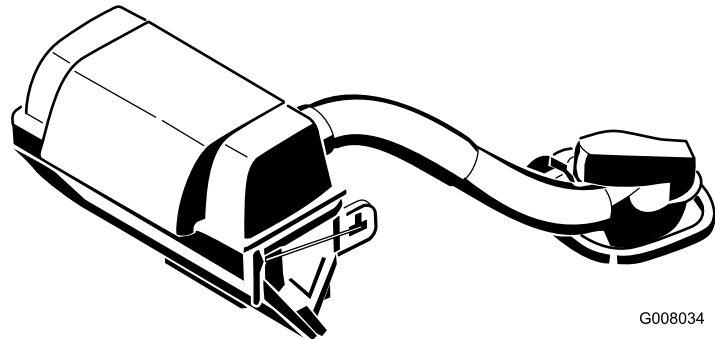

G008034



Introduction

Read this information carefully to learn how to operate and maintain your product properly and to avoid injury and product damage. You are responsible for operating the product properly and safely.

You may contact Toro directly at www.Toro.com for product safety and operation training materials, accessory information, help finding a dealer, or to register your product.

Whenever you need service, genuine Toro parts, or additional information, contact an Authorized Service Dealer or Toro Customer Service and have the model and serial numbers of your product ready. [Figure 1](#) and [Figure 2](#) identifies the location of the model and serial numbers on the product. Write the numbers in the space provided.

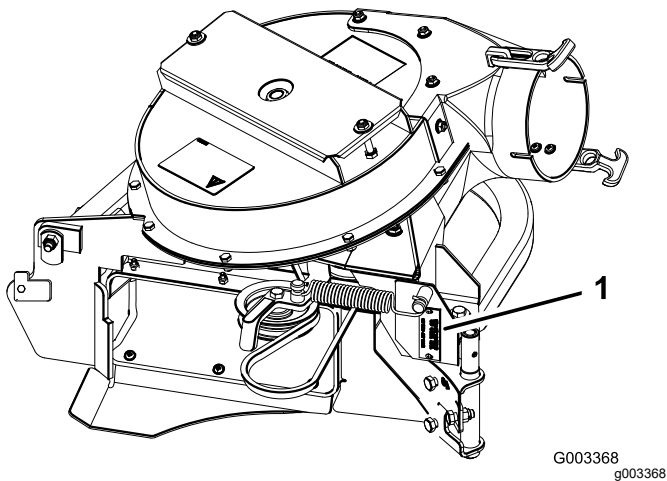

Figure 1

1. Blower model and serial number location

| |
|---|
| Model No. _____ Serial No. _____ |
|---|

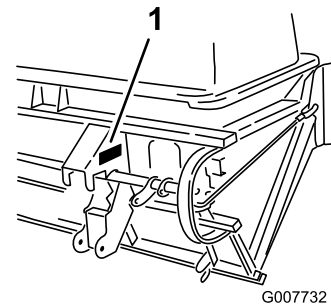

Figure 2

Bagger Serial Number

1. Bagger model and serial number location

| |
|---|
| Model No. _____ Serial No. _____ |
|---|

This manual identifies potential hazards and has safety messages identified by the safety alert symbol ([Figure 3](#)), which signals a hazard that may cause serious injury or death if you do not follow the recommended precautions.



Figure 3

1. Safety alert symbol

This manual uses 2 words to highlight information. **Important** calls attention to special mechanical information and **Note** emphasizes general information worthy of special attention.

Contents

| | |
|--|----|
| Safety | 3 |
| Safety and Instructional Decals | 4 |
| Setup | 5 |
| 1 Preparing the Mower | 6 |
| 2 Installing the Bagger Mounting Bracket | 6 |
| 3 Installing the Handle Assembly | 8 |
| 4 Tightening all Mounting Bolts | 9 |
| 5 Installing the Bagger Assembly | 9 |
| 6 Routing the Blower Belt into the Blower Assembly | 10 |
| 7 Installing the Blower Assembly | 10 |
| 8 Sizing the Upper Tube for 152 cm (60 inch) Mowers with Gas Engines | 12 |
| 9 Installing the Discharge Tubes | 13 |
| 10 Installing the Belt Cover | 16 |

Safety

The following list contains safety information specific to Toro products and other safety information you must know.

- Become familiar with the safe operation of the equipment, with the operator controls, and safety signs.
- Use extra care with grass catchers or other attachments. These can change the operating characteristics and the stability of the machine.
- Follow the manufacturer's recommendations for adding or removing wheel weights or counterweights to improve stability.
- Do not use a grass catcher on steep slopes. A heavy grass catcher could cause loss of control or overturn the machine.
- Slow down and use extra care on hillsides. Be sure to travel in the recommended direction on hillsides. Turf conditions can affect the machine's stability. Use extreme caution while operating near drop-offs. Refer to the traction unit *Operator's Manual* for operation near slopes and drop-offs.
- Keep all movement on slopes slow and gradual. Do not make sudden changes in speed, directions or turning.
- The grass catcher can obstruct the view to the rear. Use extra care when operating in reverse.
- Use care when loading or unloading the machine into a trailer or truck. If the machine is to be driven on to a truck or trailer with the hopper full, always back up the ramp.
- Never operate with the discharge deflector raised, removed or altered, unless using a grass catcher.
- Keep hands and feet away from moving parts. Do not make adjustments with the engine running.
- Stop on level ground, disengage drives, chock or block wheels, shut off engine before leaving the operator's position for any reason including emptying the grass catcher or unclogging the chute.
- If you remove the grass catcher, be sure to install any discharge deflector or guard that might have been removed to install the grass catcher. Do not operate the mower without either the entire grass catcher or the grass deflector in place.
- Stop the engine before removing the grass catcher or unclogging the chute.
- Do not leave grass in grass catcher for extended periods of time.
- Grass catcher components are subject to wear, damage and deterioration, which could expose moving parts or allow objects to be thrown. Frequently check components and replace

| | |
|--|----|
| 11 Installing the Weights | 17 |
| 12 Adjusting the Parking Brake | 17 |
| 13 Checking the Tire Pressure | 18 |
| Operation | 19 |
| Positioning the Adjustable Baffle | 19 |
| Emptying the Bagger | 20 |
| Clearing Obstructions from the Collection System | 20 |
| Removing the Bagger | 20 |
| Using the Grass Deflector | 21 |
| Transporting Machines | 21 |
| Operating Tips | 21 |
| Maintenance | 23 |
| Recommended Maintenance Schedule(s) | 23 |
| Cleaning the Bagger Screen | 23 |
| Cleaning the Collection System | 23 |
| Inspecting the Blower Belt | 23 |
| Replacing the Blower Belt | 23 |
| Checking and Adjusting the Blower Latch | 24 |
| Greasing the Idler Arm and Handle Pivot | 24 |
| Inspecting the Collection System | 25 |
| Adjusting the Door Closing | 25 |
| Adjusting the Door Opening | 25 |
| Adjusting the Latches | 26 |
| Inspecting the Mower Blades | 26 |
| Installing the Mower Blades | 26 |
| Installing the Grass Deflector | 27 |
| Storage | 28 |
| Troubleshooting | 29 |

with manufacturer's recommended parts, when necessary.

Safety and Instructional Decals



Safety decals and instructions are easily visible to the operator and are located near any area of potential danger. Replace any decal that is damaged or lost.



1-653554

decal1-653554



106-3339

decal106-3339



1-653558

decal1-653558



98-5954

decal98-5954

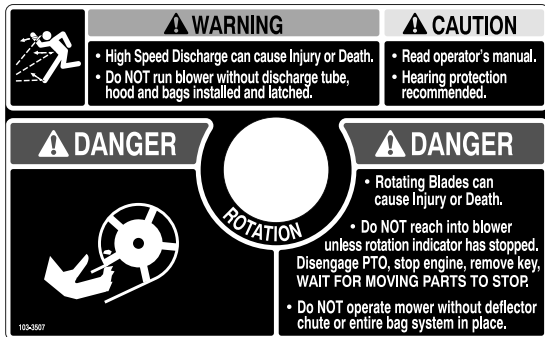

103-3507

decal103-3507

Setup

Loose Parts

Use the chart below to verify that all parts have been shipped.

| Procedure | Description | Qty. | Use |
|-----------|---|------------------------------------|---|
| 1 | No parts required | – | Prepare the mower. |
| 2 | Bagger mounting bracket Bagger side plate Spacer Bolt (3/8 x 1-1/2 inches) Bolt (3/8 x 1 inch) (for Z593 mowers only) Flange nut (3/8 inch) Curved washer | 1 2 2 14 2 14 14 | Install the bagger mounting bracket. |
| 3 | Handle assembly Washer Bolt (3/8 x 1-1/4 inches) Clevis-pin spring Locknut (3/8 inch) | 1 2 3 1 3 | Install the handle assembly. |
| 4 | No parts required | – | Tighten all mounting bolts. |
| 5 | Bagger assembly Clevis pin Hairpin cotter | 1 2 2 | Install the bagger assembly. |
| 6 | Blower belt (from the Blower and Drive Kit) | 1 | Route the blower belt into the blower assembly. |
| 7 | Blower assembly (from the Blower and Drive Kit) Spring (from the Blower and Drive Kit) | 1 1 | Install the blower assembly. |
| 8 | Upper tube | 1 | Size the upper tube for 152 cm (60 inch) mowers with gas engines. |
| 9 | Upper tube Lower tube Bolt (#10 x 3/4 inches) Locknut (#10) Washer (7/32 inch) | 1 1 3 3 3 | Install the discharge tubes. |
| 10 | Belt cover (from the Blower and Drive Kit) | 1 | Install the belt cover. |
| 11 | Caster weight (if needed) U-bolt Nut (1/2 inch) Lock washer (1/2 inch) Plate Top weight (for 60 inch mower decks only) | 2 2 4 4 2 2 | Install the weights. |
| 12 | No parts required | – | Adjust the parking brake. |
| 13 | No parts required | – | Check the tire pressure. |

Note: Determine the left and right sides of the machine from the normal operating position.

1

Preparing the Mower

No Parts Required

Procedure

Perform the following procedure to prepare the mower for attaching the blower and finishing kit.

1. Disengage the PTO, move the motion-control levers to the NEUTRAL-LOCKED position and set the parking brake.
2. Stop the engine, remove the key, and wait for all moving parts to stop before leaving the operating position.
3. Repair all bent or damaged areas of mower deck and replace any missing parts.
4. Clean the mower of any debris on the deck or rear part of the mower to ease installation.

2

Installing the Bagger Mounting Bracket

Parts needed for this procedure:

| | |
|----|--|
| 1 | Bagger mounting bracket |
| 2 | Bagger side plate |
| 2 | Spacer |
| 14 | Bolt (3/8 x 1-1/2 inches) |
| 2 | Bolt (3/8 x 1 inch) (for Z593 mowers only) |
| 14 | Flange nut (3/8 inch) |
| 14 | Curved washer |

Procedure

Important: Do not tighten any bolts until both side brackets and bagger mounting bracket are fit loose on the machine.

Refer to Tightening the Mounting Bolts for the correct procedure to tighten the bolts.

1. Remove the bolts, nuts, and washers holding the roll bar to one side of the machine. Discard the nuts, bolts, and washers (Figure 4, Figure 5, and Figure 6).
2. Install the bagger side plate and the roll bar section to the side of the machine using 4 bolts (3/8 x 1-1/2 inches), 4 curved washers (3/8 inch), and 4 flange nuts (3/8 inch) (Figure 4, Figure 5, and Figure 6).
3. Repeat the steps above for the opposite side (Figure 4, Figure 5, and Figure 6).

Note: Make sure the curved washers are installed as shown in Figure 4, Figure 5, and Figure 6.

4. Install the bagger mounting bracket to the left and right side bagger brackets with 4 bolts (3/8 x 1-1/2 inches), 4 curved washers (3/8 inch), and 4 flange nuts (3/8 inch) (Figure 4, Figure 5, and Figure 6).
5. Install the bagger mounting bracket to the rear frame of the machine with 2 bolts (3/8 x 1-1/2 inches) (use 2 bolts (3/8 x 1 inch) for Z593 mowers as shown in Figure 5), 2 curved washers (3/8 inch), and 2 flange nuts (3/8 inch) (Figure 4, Figure 5, and Figure 6).

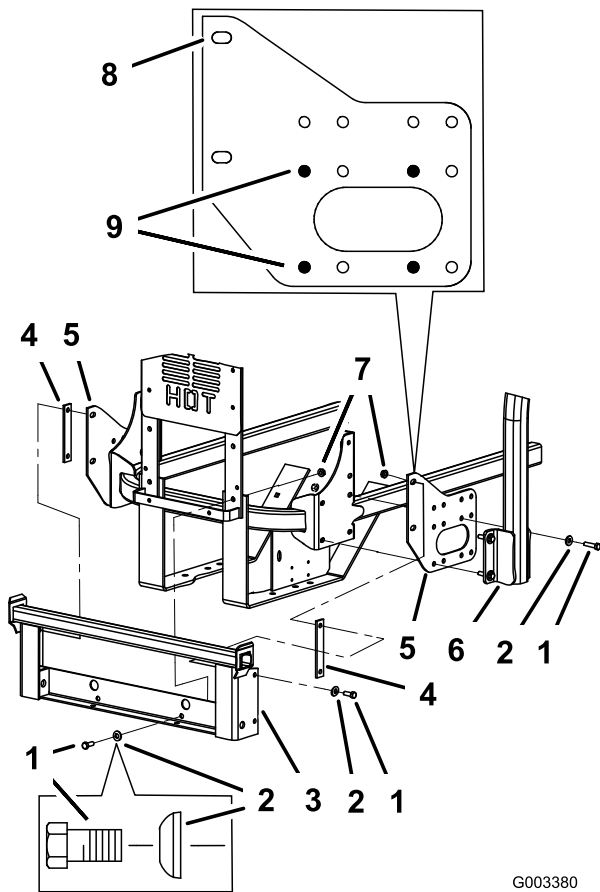

G003380
g003380

Figure 4
For Z500 Gas Mowers

- | | |
|------------------------------|--|
| 1. Bolt (3/8 x 1-1/2 inches) | 6. ROPS |
| 2. Curved washer (3/8 inch) | 7. Flange nut (3/8 inch) |
| 3. Bagger mounting bracket | 8. Side view of bagger side plate |
| 4. Spacer | 9. Holes to use when installing the side bracket |
| 5. Bagger side plate | |

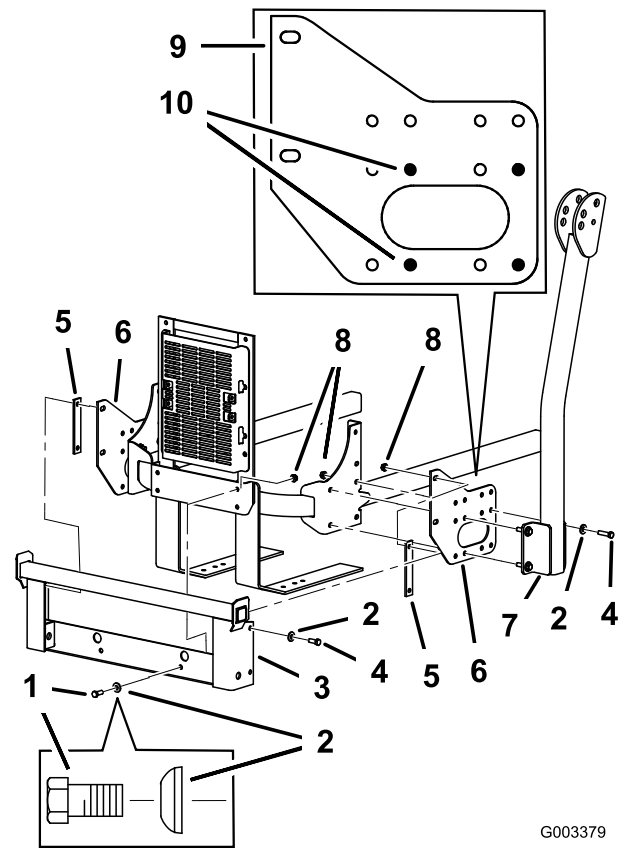

G003379
g003379

Figure 5
For Kubota Diesel Mowers

- | | |
|------------------------------|---|
| 1. Bolt (3/8 x 1 inch) | 6. Bagger side plate |
| 2. Curved washer (3/8 inch) | 7. ROPS |
| 3. Bagger mounting bracket | 8. Flange nut (3/8 inch) |
| 4. Bolt (3/8 x 1-1/2 inches) | 9. Side view of bagger side plate |
| 5. Spacer | 10. Holes to use when installing the side bracket |

3

Installing the Handle Assembly

Parts needed for this procedure:

| | |
|---|---------------------------|
| 1 | Handle assembly |
| 2 | Washer |
| 3 | Bolt (3/8 x 1-1/4 inches) |
| 1 | Clevis-pin spring |
| 3 | Locknut (3/8 inch) |

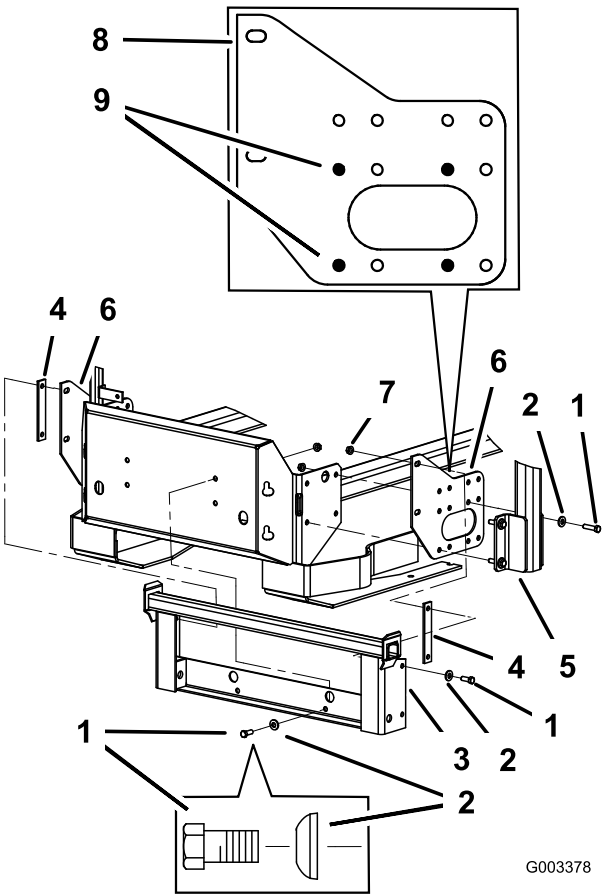

Figure 6

For Daihatsu Diesel Mowers

- 1. Bolt (3/8 x 1-1/2 inches)
- 2. Curved washer, (3/8 inch)
- 3. Bagger mounting bracket
- 4. Spacer
- 5. Bagger side plate
- 6. ROPS
- 7. Flange nut (3/8 inch)
- 8. Side view of bagger side plate
- 9. Holes to use when installing the side bracket

Procedure

1. Position the handle assembly between the ROPS roll bar and the bagger mounting bracket (Figure 8).
2. Install the handle assembly to the bagger mounting bracket and the machine with 3 bolts (3/8 x 1-1/4 inches) and 3 locknuts (3/8 inch) (Figure 7 and Figure 8).

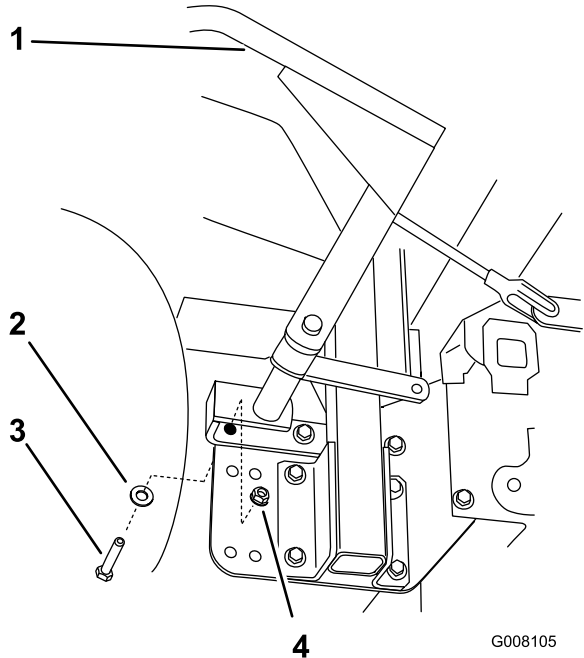

Figure 7

- 1. Handle assembly
- 2. Washer
- 3. Bolt (3/8 x 1-1/4 inches)
- 4. Nut (3/8 inch)

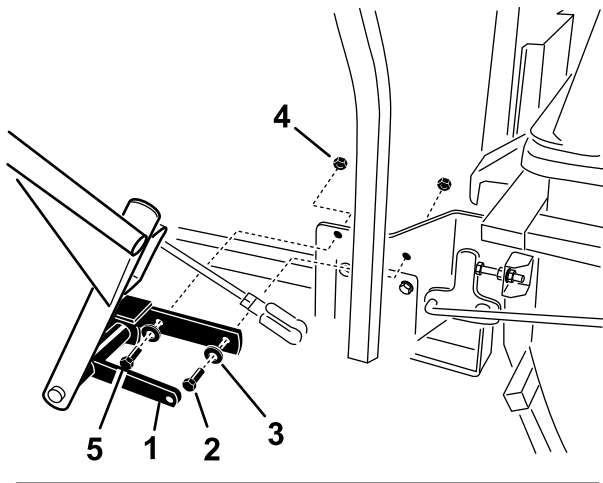

Figure 8

- | | |
|------------------------------|---|
| 1. Handle assembly | 4. Nut (3/8 inch) |
| 2. Bolt (3/8 x 1-1/4 inches) | 5. This bolt is not used on Kubota powered machines |
| 3. Washer | |

3. Install the bagger arm linkage to the bagger assembly with a clevis pin spring (Figure 9).

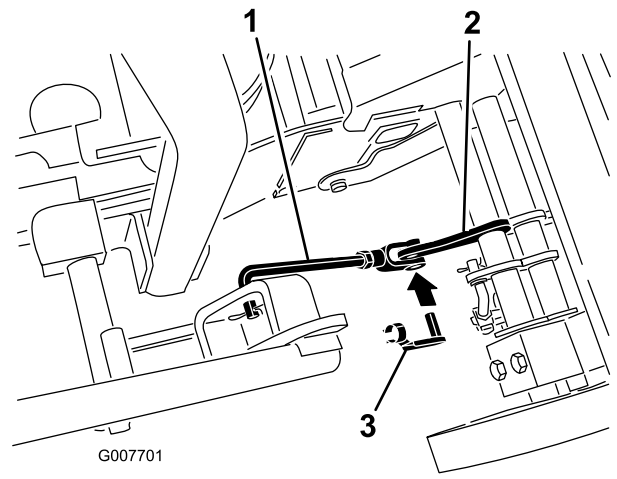

Figure 9

- | | |
|--------------------|----------------------|
| 1. Bagger arm link | 3. Clevis pin spring |
| 2. Bagger assembly | |

4

Tightening all Mounting Bolts

No Parts Required

Procedure

The following steps are the correct sequence to tighten the side brackets and the bagger mounting bracket. All mounting bolts need to be torqued to 48 N·m (35 ft-lb).

1. Tighten the bagger mounting bracket to the rear frame first.
2. Tighten the ROPS and side brackets to the side of the mower.
3. If the bagger mounting bracket moves side to side an 1/8 inch or more, install one or both of the spacers between the bagger mounting bracket and mounting plates (Figure 4, Figure 5, and Figure 6).
4. Tighten the bagger mounting bracket to the side brackets.

5

Installing the Bagger Assembly

Parts needed for this procedure:

| | |
|---|-----------------|
| 1 | Bagger assembly |
| 2 | Clevis pin |
| 2 | Hairpin cotter |

Procedure

1. Install the bagger assembly onto the bagger mounting bracket (Figure 10).
2. Install the 2 clevis pins into the bagger assembly and bagger mounting bracket. Secure it with 2 hairpin cotters (Figure 10).

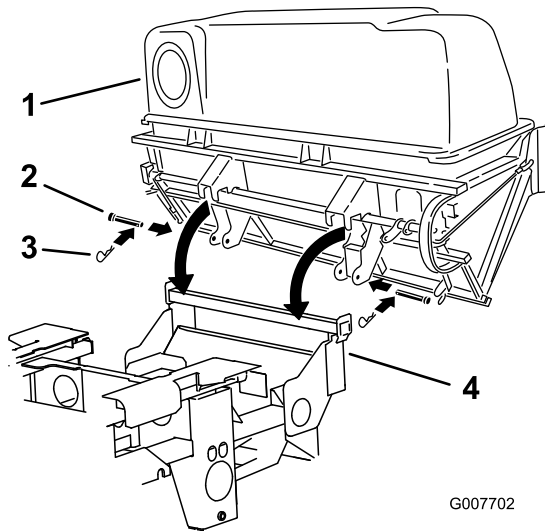

Figure 10

- | | |
|------------------|----------------------------|
| 1. Hood assembly | 3. Hairpin cotter |
| 2. Clevis pin | 4. Bagger mounting bracket |

6

Routing the Blower Belt into the Blower Assembly

Parts needed for this procedure:

| | |
|---|---|
| 1 | Blower belt (from the Blower and Drive Kit) |
|---|---|

Procedure

1. Install the belt around the blower pulley (Figure 11).
2. Install the spring to the idler arm and the peg on the blower assembly (Figure 11).

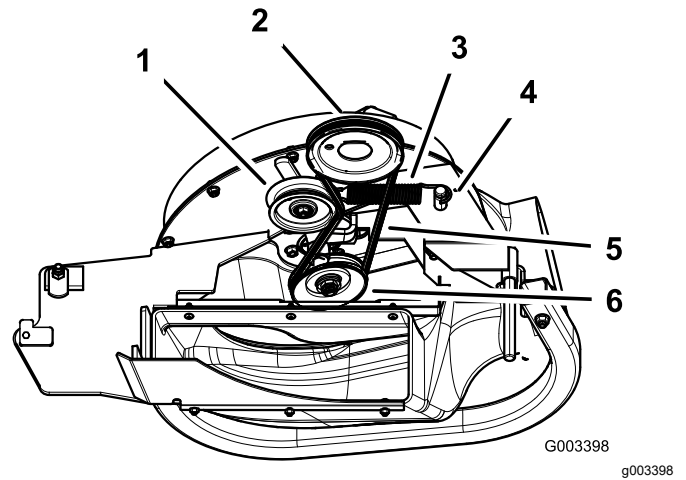

Figure 11

- | | |
|----------------------|------------------|
| 1. Idler pulley | 4. Peg |
| 2. Mower-deck pulley | 5. Belt |
| 3. Spring | 6. Blower pulley |

7

Installing the Blower Assembly

Parts needed for this procedure:

| | |
|---|---|
| 1 | Blower assembly (from the Blower and Drive Kit) |
| 1 | Spring (from the Blower and Drive Kit) |

Procedure

⚠ WARNING

An uncovered discharge opening could allow the lawn mower to throw objects at you or bystanders, resulting in serious injury. Also, contact with the blade could occur.

- Never operate the lawn mower unless you install a cover plate, a mulch plate, or a grass chute and catcher.
- Make sure that the grass deflector is installed when you remove the grass chute and catcher.

1. Remove the side-discharge chute from the mower deck (Figure 12).

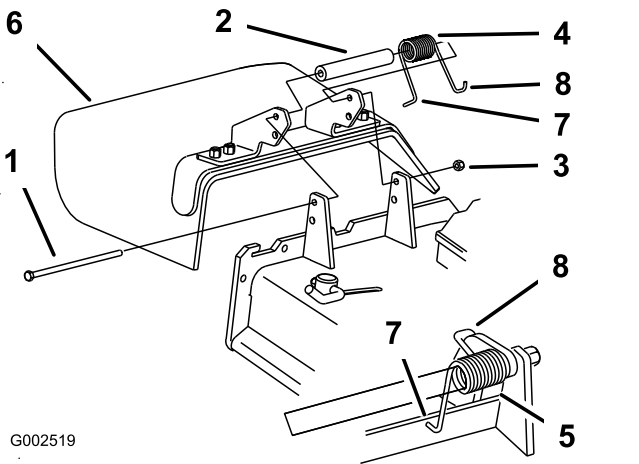

Figure 12

- | | |
|------------|---|
| 1. Bolt | 5. Spring installed |
| 2. Spacer | 6. Grass deflector |
| 3. Locknut | 7. L-end of spring (Place it behind the deck edge before installing the bolt) |
| 4. Spring | 8. J-hook end of the spring |

2. Slide the blower-assembly peg into the pivot hole. For 152 cm (60 inch) mowers refer to Figure 13 and for 183 cm (72 inch) mowers refer to Figure 14.

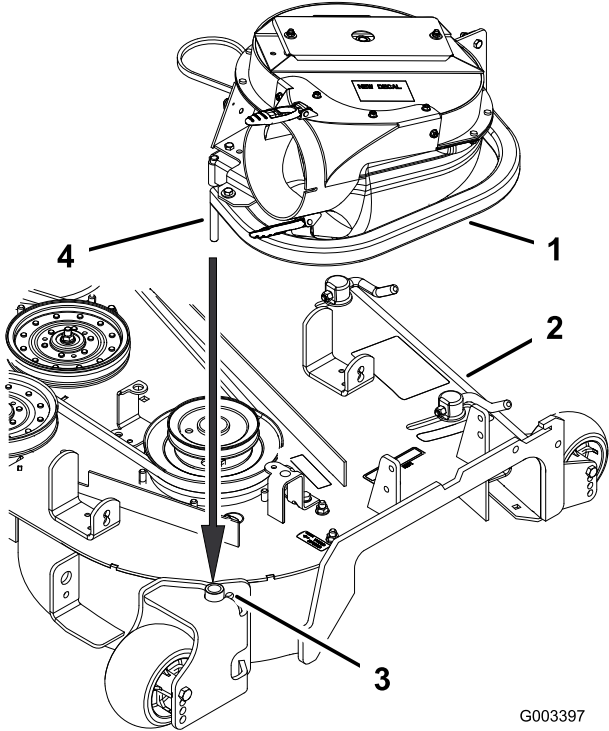

Figure 13

152 cm (60 inch) Mower Deck

- | | |
|---------------------------------------|------------------------------|
| 1. Blower assembly | 3. Pivot hole |
| 2. Mower deck, 152 cm (60 inch) shown | 4. Blower-assembly peg shown |

G003397
g003397

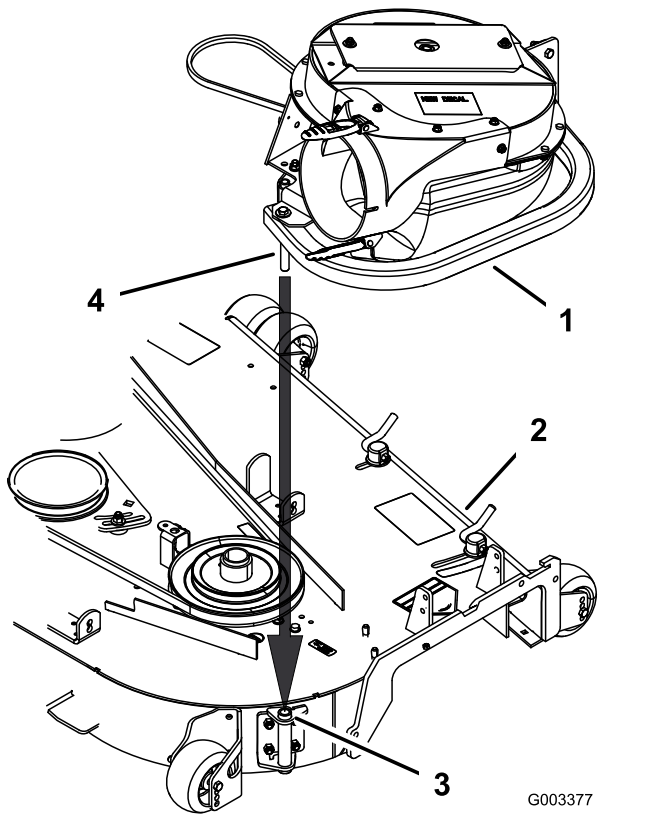

Figure 14

183 cm (72 inch) Mower Deck

- | | |
|---------------------------------------|------------------------|
| 1. Blower assembly | 3. Pivot hole |
| 2. Mower deck, 183 cm (72 inch) shown | 4. Blower-assembly peg |

3. Close the blower assembly to see if the latches are adjusted correctly (Figure 15).

Note: Loosen or tighten the bolt so the latches firmly hold the blower assembly against the mower deck but can be released by hand (Figure 15).

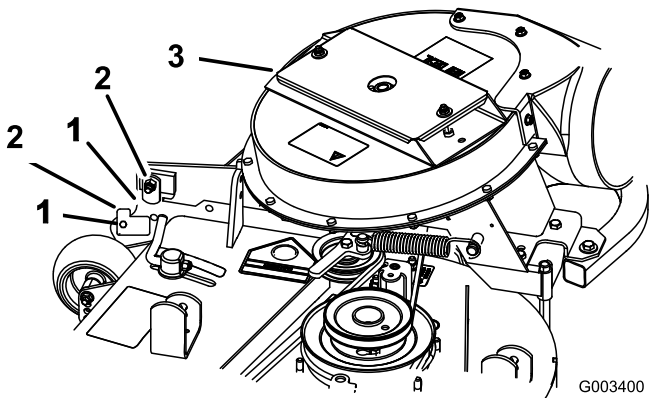

Figure 15

- | | |
|----------|--------------------|
| 1. Latch | 3. Blower assembly |
| 2. Bolt | |

4. Install the spring as shown in Figure 16.

Note: Make sure that the hooks are in the correct position.

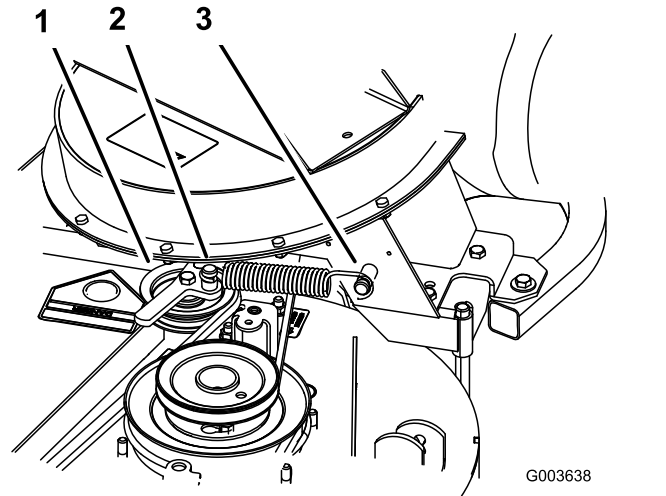

Figure 16

- | | |
|-------------------------------|------------------|
| 1. Spring-loaded idler pulley | 3. Long-hook end |
| 2. Short-hook end | |

5. Pull the spring-loaded idler pulley back and route the belt around the mower-deck pulley (Figure 17).

Note: Ensure that the belt is routed around the blower pulleys correctly (Figure 17).

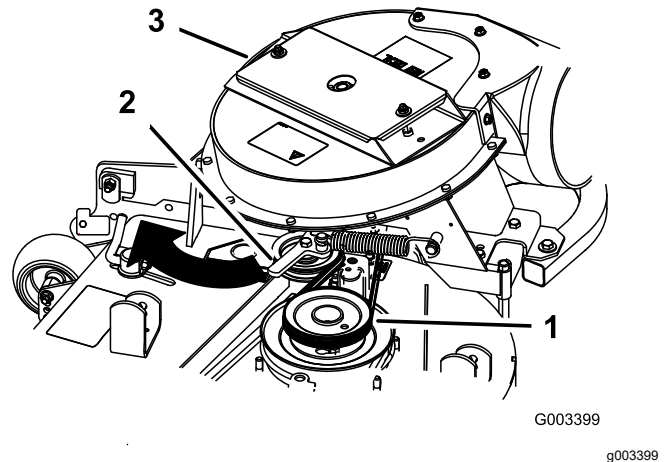

Figure 17

- | | |
|-------------------------------|-----------|
| 1. Mower-deck pulley | 3. Blower |
| 2. Spring-loaded Idler pulley | |

8

Sizing the Upper Tube for 152 cm (60 inch) Mowers with Gas Engines

Parts needed for this procedure:

| | |
|---|------------|
| 1 | Upper tube |
|---|------------|

Procedure

Note: This procedure is for 152 cm (60 inch) mowers with gas engines only.

1. Measure up 89 mm (3-1/2 inches) from the bottom of the upper tube. Use the existing 3 holes as marks and then mark it in several places to create a line around the tube (Figure 18).
2. Cut the 89 mm (3-1/2 inches) off the upper tube (Figure 18).

Note: Notice the three indentations in the tube. This is where holes will be drilled in the following procedure.

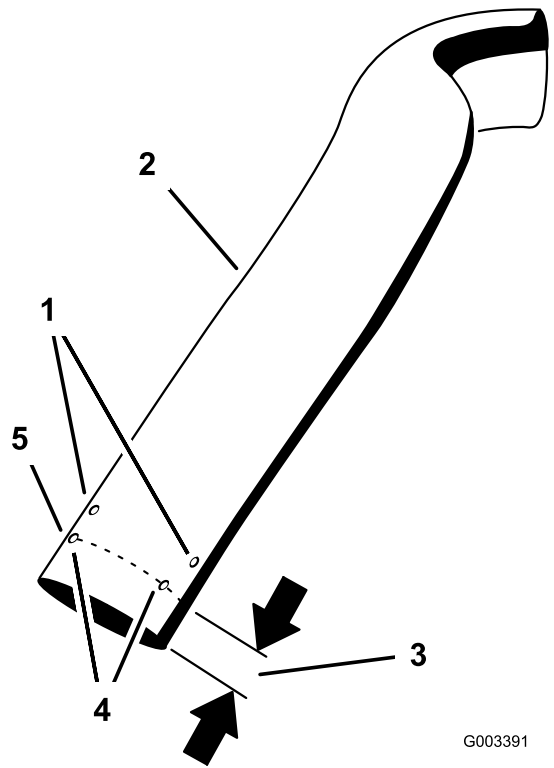

Figure 18

G003391

g003391

1. Indentations for drilling holes
2. Upper tube
3. Cut off 89 mm (3-1/2 inches) for 152 cm (60 inch) mowers with gas engines only
4. Use the existing holes to create a line
5. Line to cut tube

9

Installing the Discharge Tubes

Parts needed for this procedure:

| | |
|---|-------------------------|
| 1 | Upper tube |
| 1 | Lower tube |
| 3 | Bolt (#10 x 3/4 inches) |
| 3 | Locknut (#10) |
| 3 | Washer (7/32 inch) |

Procedure

Important: Make sure that the mower deck is in the lowest height-of-cut position while installing the discharge tubes.

Note: Remember to replace the grass deflector when the bagger is removed from the mower. Refer to [Installing the Grass Deflector \(page 27\)](#).

1. Disengage the PTO and set the parking brake.
2. Stop the engine, remove the key, and wait for all moving parts to stop before leaving the operating position.
3. Lower the mower deck to the lowest height-of-cut position.
4. Install the upper tube into the bagger opening and pull it back out so that the rubber seal is protruding out ([Figure 19](#)).

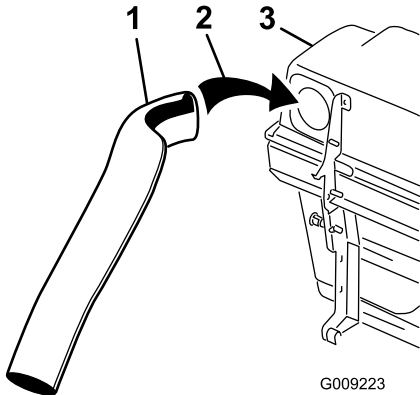

Figure 19

1. Upper tube
2. Bagger opening
3. Bagger hood

5. Measure the distance the tube is inside the hood.

Note: Measure from the hood plate to the edge of the tube as shown in [Figure 20](#). This distance needs to be 19 mm (3/4 inch).

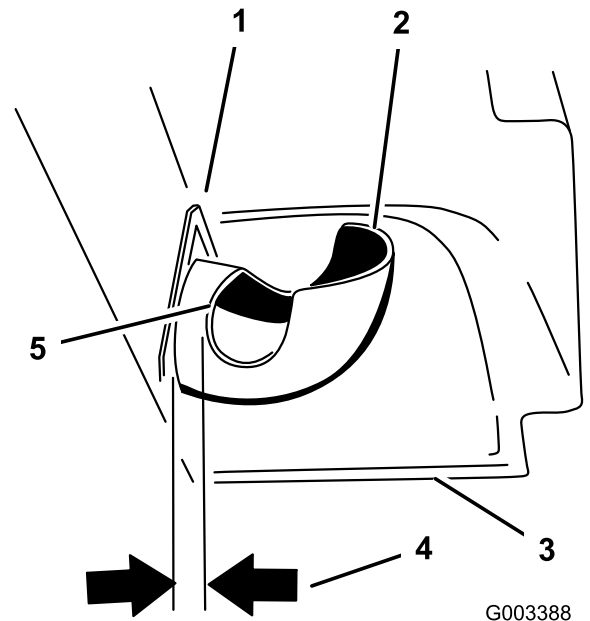

Figure 20

1. Hood plate
2. Upper tube
3. Hood in the down position
4. 19 mm (3/4 inch)
5. Edge of tube

6. Once the 19 mm (3/4 inch) measurement has been achieved, mark the upper tube on the outside where the rubber seal protrudes out ([Figure 21](#)).

Note: This is marked to ensure the correct position for the upper tube when drilling the holes and connecting the upper and lower tubes.

Note: The rubber seal must protrude out from the bagger hood.

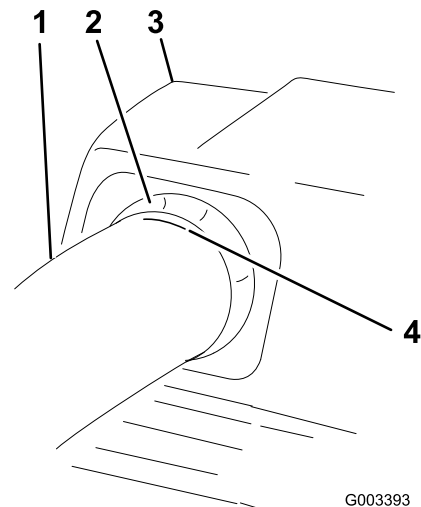

Figure 21

1. Upper tube
2. Rubber seal protruding out
3. Bagger hood
4. Mark here against the rubber seal.

7. Install the lower tube into the upper tube (Figure 22).

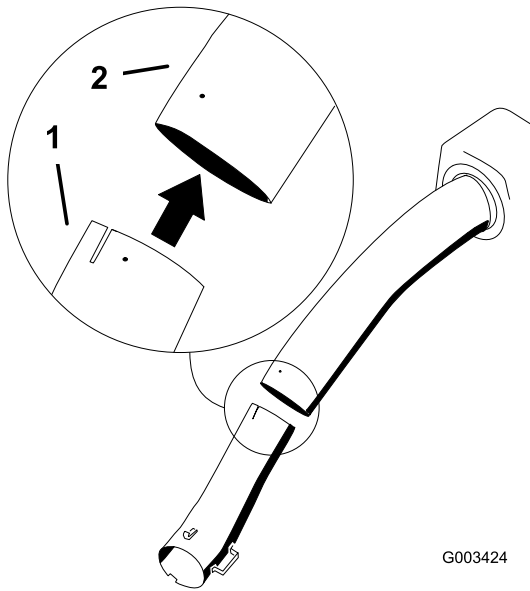

Figure 22

1. Lower tube
2. Upper tube

8. Slide the lower tube onto the boot and latch them together (Figure 23).

Note: There is a latch on the top and bottom of the blower housing.

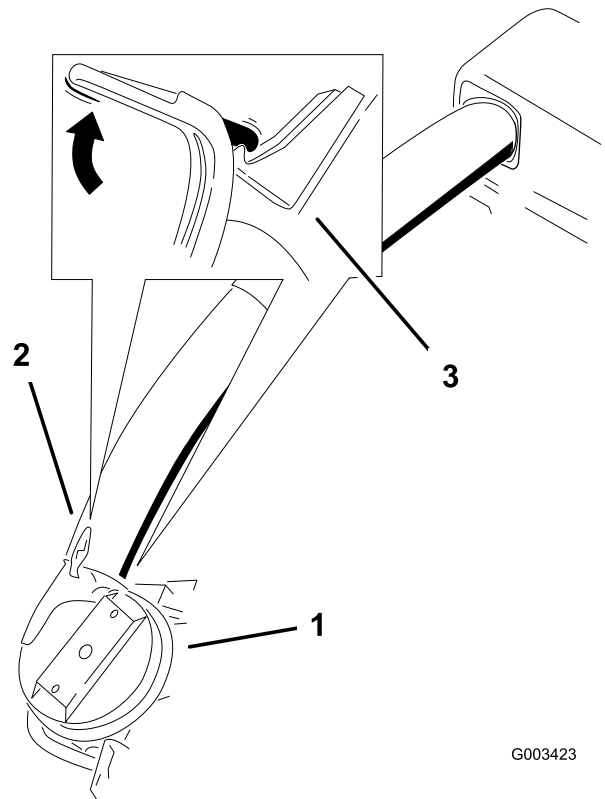

Figure 23

1. Blower assembly
2. Lower tube
3. Latch

9. Make sure that the mower deck is in the lowest height-of-cut position and the mark on the upper tube is still positioned against the protruding rubber seal.

Check to make sure that the mark from Figure 21 is still in place.

- Using the 3 holes or indentations in the upper tube as a template, drill 3 holes (7/32 inch diameter) where the upper and lower tubes join together (Figure 24).

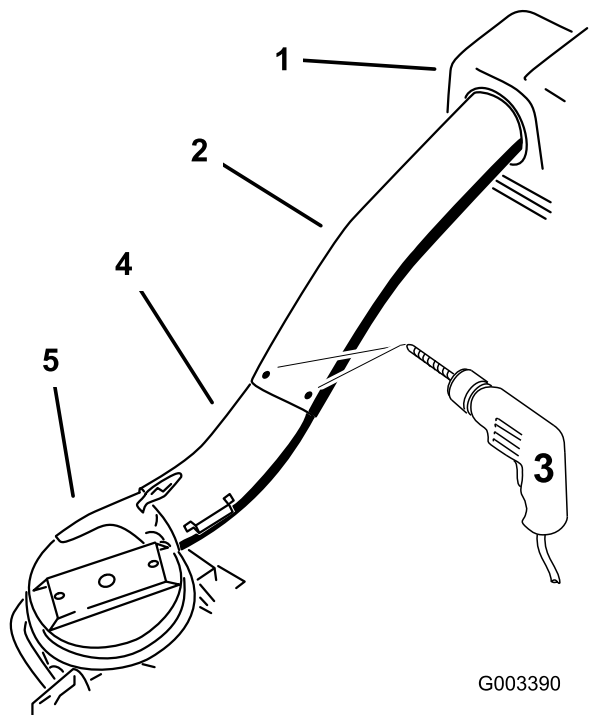

Figure 24

- | | |
|---|--------------------|
| 1. Bagger hood | 4. Lower tube |
| 2. Upper tube | 5. Blower assembly |
| 3. Drill 7/32 inch diameter holes here (use the upper tube as a template) | |

- Remove the lower tube from the blower.

- Join the upper and lower tubes with 3 bolts (#10 x 3/4 inches), 3 flat washers (7/32 inch), and 3 locknuts (#10) as shown in Figure 25.

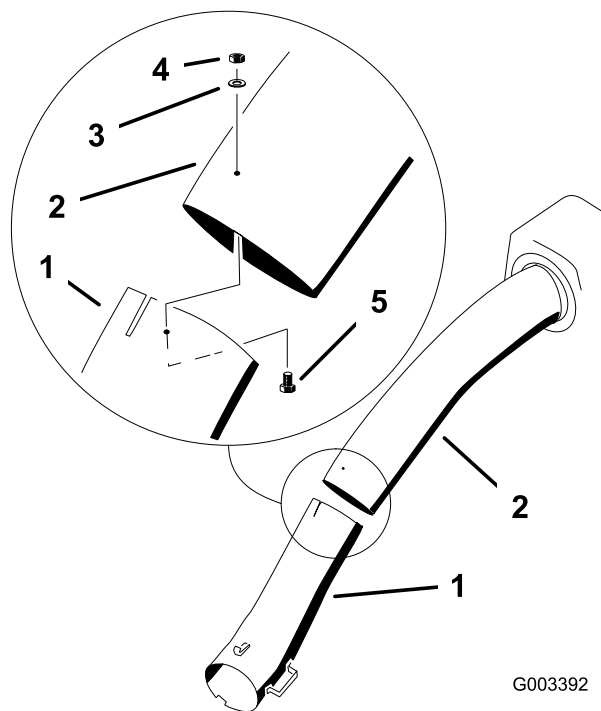

Figure 25

- | | |
|----------------------------|-----------------------------|
| 1. Lower tube | 4. Locknut (#10) |
| 2. Upper tube | 5. Bolt, (#10 x 3/4 inches) |
| 3. Flat washer (7/32 inch) | |

- Install the lower tube onto the blower housing and secure it with the latches.

10

Installing the Belt Cover

Parts needed for this procedure:

| | |
|---|--|
| 1 | Belt cover (from the Blower and Drive Kit) |
|---|--|

Procedure

- Lower the mower deck to the lowest height-of-cut position.
- Install the new belt cover so that the notches on both sides go over the belt-cover supports and secure the latch (Figure 26).

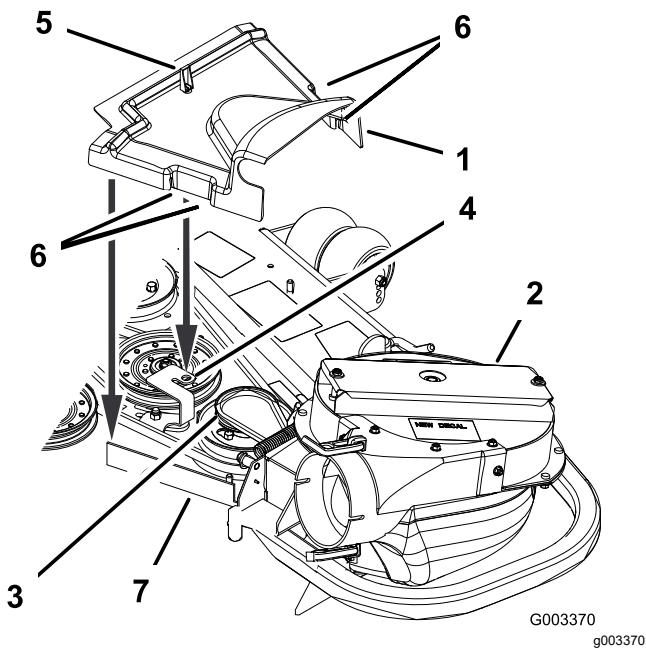

Figure 26

- | | |
|-----------------------|-----------------------|
| 1. Belt cover | 5. Latch |
| 2. Blower assembly | 6. Belt cover notch |
| 3. Pulley assembly | 7. Belt cover support |
| 4. Belt cover bracket | |

2. Install plate, nuts (1/2 inch) and lock washer (1/2 inch) under the frame and weight (Figure 27).
3. Repeat for opposite side.

Note: All Z Master mowers receive the caster weights.

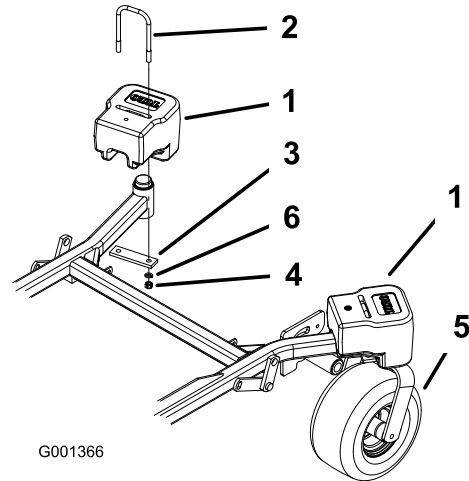

Figure 27

- | | |
|------------------------|-----------------|
| 1. Front caster weight | 4. Nut |
| 2. U-bolt | 5. Front caster |
| 3. Plate | 6. Lock washer |

Note: Only Z Master mowers with 153 cm (60 inch) mower decks receive the top weights.

4. Install the top weights on top of each caster weight for 153 cm (60 inch) mowers with 2 bolts (1/2 x 2-1/2 inches) (Figure 28).

11

Installing the Weights

Parts needed for this procedure:

| | |
|---|---|
| 2 | Caster weight (if needed) |
| 2 | U-bolt |
| 4 | Nut (1/2 inch) |
| 4 | Lock washer (1/2 inch) |
| 2 | Plate |
| 2 | Top weight (for 60 inch mower decks only) |

Procedure

To comply with ANSI/OPEI B71.4-2004 Standard, you must add weights to the machine.

⚠ CAUTION

The bagger adds a lot of weight to the rear of the machine and may cause an unstable condition, which could result in a loss of control.

1. Place caster weights on the front casters.

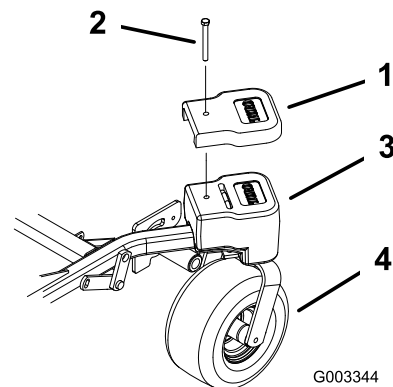

Figure 28

- | | |
|------------------------------|------------------------|
| 1. Top weight | 3. Front caster weight |
| 2. Bolt (1/2 x 2-1/2 inches) | 4. Front caster wheel |

12

Adjusting the Parking Brake

No Parts Required

Procedure

Check the parking brake for proper adjustment.

1. Disengage brake lever (lever down).
2. Measure the length of the spring.

The measurement should be 70 mm (2-3/4 inch) between washers (Figure 29).

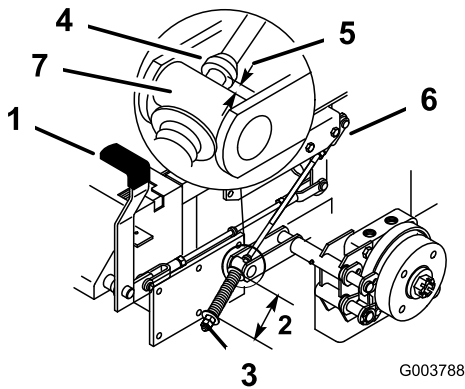

Figure 29

- | | |
|--------------------------------|---------------------------|
| 1. Brake lever | 5. 5–7 mm (3/16–1/4 inch) |
| 2. Spring (2-3/4 inches/70 mm) | 6. Jam nut and yoke |
| 3. Adjusting nuts | 7. Trunnion roller |
| 4. Collar on brake rod | |

3. If adjustment is necessary, loosen the jam nut below the spring and tighten the nut directly below the yoke (Figure 29). Turn the nut until the correct measurement is obtained. Tighten the two nuts together and repeat on opposite side of unit.
4. Turn nuts clockwise to shorten spring length and turn counter-clockwise to lengthen the spring.
5. Engage parking brake, lever up.
6. Measure the distance between the trunnion roller and the collar on brake rod. The measurement should be 5–7 mm (3/16–1/4 inch) (Figure 29).
7. If adjustment is necessary, loosen the jam nut directly below the yoke. Turn the bottom rod until

the correct measurement is obtained (Figure 29). Tighten jam nut at the yoke.

13

Checking the Tire Pressure

No Parts Required

Procedure

Note: Increase the tire pressure due to the additional weight.

Check and increase the air pressure in the front caster wheels and the rear tires (Figure 30).

Pressure:

Rear tires: 138 kPa (20 psi)

Front caster wheels: 172 kPa (25 psi)

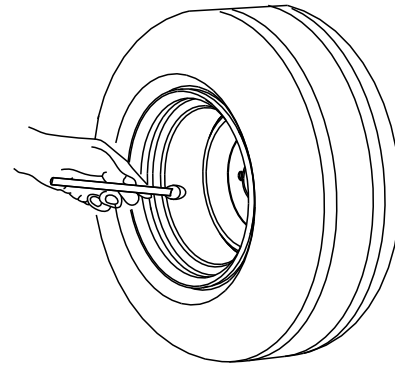

Figure 30

Operation

Note: Determine the left and right sides of the machine from the normal operating position.

Important: Set the parking brake when you leave the machine, even if just for a few minutes.

⚠ WARNING

To avoid personal injury, follow these procedures:

- Become familiar with all operating and safety instructions in the *Operator's Manual* for your machine before using this attachment.
- Never remove the bagger or bagger tubes while the engine is running.
- Always shut the engine off and wait for all moving parts to stop before clearing an obstruction from the bagging system.
- Never do maintenance or repairs while the engine is running.
- Set the parking brake.

⚠ WARNING

Without the grass deflector, bagger tubes or complete collection system mounted in place, you and others are exposed to blade contact and thrown debris. Contact with the rotating mower blade(s) and thrown debris will cause injury or death.

- Always install the grass deflector when you remove the collection system and change to side-discharge mode.
- If the grass deflector is ever damaged, replace it immediately. The grass deflector routes material down toward the turf.
- Never put your hands or feet under the mower.
- Never try to clear the discharge area or mower blades unless you move the power take off (PTO) to off and rotate the ignition key to off. Also remove the key and pull the wire off the spark plug(s).
- Turn off the engine before unclogging the discharge chute.
- Never use your hands to unclog the discharge chute, use a stick or similar object.

⚠ CAUTION

Children or bystanders may be injured if they move or attempt to operate the tractor while it is unattended.

Always remove the ignition key and set the parking brake when leaving the machine unattended, even if just for a few minutes.

Positioning the Adjustable Baffle

Adjust the baffle to position B (middle position) for bagging. Refer to the *Operator's Manual* for the machine for the baffle adjustment procedure.

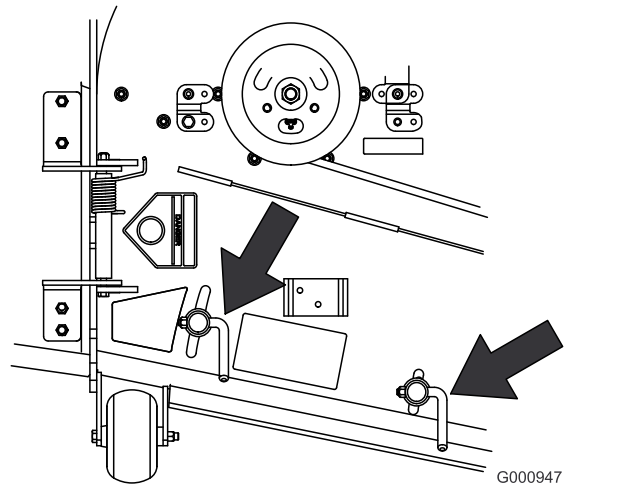

Figure 31

Emptying the Bagger

1. Disengage the PTO and set the parking brake.
2. Lift the handle to open the door and empty the hopper.
3. Push the handle down to close the door ([Figure 32](#)).

Note: If the machine is to be driven on to a truck or trailer with the hopper full, always back up the ramp. This will reduce the chance of rearward tip.

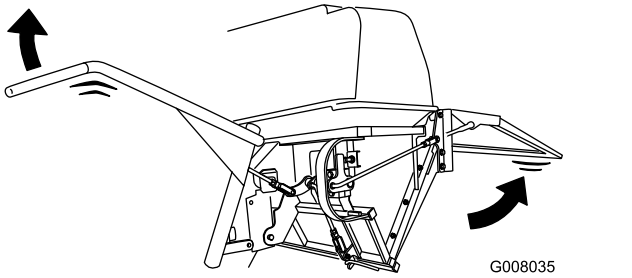

Figure 32

Clearing Obstructions from the Collection System

⚠ WARNING

When you operate collection system, the blower rotates and can cut off or injure hands.

- Before adjusting, cleaning, repairing and inspecting the blower, and before unclogging the chute, turn off the engine and wait for all moving parts to stop. Remove the key.
 - Use a stick, not your hands, to remove an obstruction from the blower and tube.
 - Keep face, hands, feet, and any other part of your body or clothing away from concealed, moving, or rotating parts.
1. Disengage the PTO and set the parking brake.
 2. Turn off the engine, remove the key, and wait for all moving parts to stop before leaving the operating position.
 3. Empty the bagger.
 4. Unlatch the lower tube.
 5. Remove the tubes from the bagger.
 6. Use a stick or similar object, not your hands, to remove and clear the obstruction from the tube assembly.

Note: In most cases, the debris can be shaken out of the tubes.

7. If the blower assembly is plugged, unlatch the blower assembly, remove the belt, and swing it open.
8. Use a stick or similar object, not your hands, to remove and clear the obstruction from the blower assembly.
9. After you remove the obstruction, install the complete collection system and resume operation.

Removing the Bagger

⚠ WARNING

Components around engine will be hot if the machine has been running. Touching hot components can cause burns.

- Do not touch engine components when they are hot.
 - Allow engine to cool before removing the bagger.
1. Disengage the PTO, set the parking brake, and chock or block the tires.
 2. Turn off the engine, remove the key, and wait for all moving parts to stop before leaving the operating position.
 3. Unlatch the lower tube from the blower and remove the tube from the blower assembly.
 4. Remove the tube from the bagger hood.
 5. Lower the mower deck to the lowest height-of-cut position.
 6. Unlatch the belt cover over the mower-pulley assembly.
 7. Remove the blower belt from the mower-pulley assembly.
 8. Open the blower assembly.
 9. Remove the blower assembly from the pivot hole.
 10. If you are changing to side-discharge mode, ensure that the grass deflector is installed and can be lowered into working position.
 11. Remove the collection system assembly.

Using the Grass Deflector

⚠ DANGER

Without the grass deflector, discharge cover, or complete grass catcher assembly mounted in place, you and others are exposed to blade contact and thrown debris. Contact with rotating mower blade(s) and thrown debris will cause injury or death.

- Always install the grass deflector when removing the collection system and changing to side discharge mode.
- If the grass deflector is ever damaged, replace it immediately. The grass deflector routes material down toward the turf.
- Never put your hands or feet under the mower.
- Never try to clear the discharge area or mower blades unless you move the power take off (PTO) to the off position, rotate the ignition key to off and remove the key.

Transporting Machines

Do not leave grass or debris in the bagger while transporting the machine on a trailer or truck.

⚠ DANGER

Transporting the machine with grass or debris in the bagger can damage the machine.

Do not leave grass or debris in the bagger while transporting the machine on a trailer or truck.

Operating Tips

Machine Size

Remember that the machine is longer and wider with this attachment installed. If you turn too sharply in confined places, you may damage the attachment or other property.

Trimming

Always trim with the left side of the mower. Do not trim with the right side of the mower because you could damage the bagging tubes.

Cutting Height

For optimum bagging performance, set the deck height-of-cut to remove no more than 51 to 76 mm

(2 to 3 inches) or 1/3 of the grass height, whichever is less. Cutting off more than this will reduce the capacity of the vacuum system.

Cutting Frequency

Cut the grass often, especially when it grows rapidly. You need to cut your grass twice if it gets excessively long; refer to [Bagging Long Grass](#) (page 21).

Cutting Technique

For best lawn appearance, be sure to slightly overlap the mower into the previously cut area. This helps reduce the load on the engine and reduces the chance of plugging the blower assembly and tubes.

Bagging Speed

The bagging system may plug if you drive too fast and the engine speed gets too slow. On hills, you may need to slow the ground speed of the machine. Mow downhill whenever possible.

⚠ CAUTION

As the bagger fills, extra weight is added to the back of the machine. If you stop and start suddenly on hills, you may lose steering control or the machine may tip.

- Do not start or stop suddenly when going uphill or downhill. Avoid uphill starts.
- If you do stop the machine when going uphill, disengage the PTO. Then back down the hill using a slow speed.
- Do not change speeds or stop on slopes.

Bagging Long Grass

If the grass grows longer than normal, or if it contains a high degree of moisture, raise the cutting height higher than usual and cut and bag the grass at this setting. Then cut and bag the grass again using the lower, normal setting.

Excessively long grass is heavy and may not be propelled completely into the bagger. If this happens, the tube and blower may plug. To avoid plugging the bagging system, mow the grass at a high height-of-cut, then lower the mower to your normal cutting height and repeat the bagging process.

Bagging Wet Grass

If possible, always try to cut grass when it is dry. Wet grass can cause plugging.

Reducing Plugging

To avoid plugging the bagging system, reduce the ground speed and mow the grass at a high height-of-cut, then lower the mower to your normal cutting height and repeat the bagging process.

Signs of Plugging

As you use the bagger, a small amount of grass clippings normally blow out the front of the mower. An excessive amount of clipping blow-out indicates that the bagger is full or the tube is plugged.

Bagging Blades

In most mowing conditions, the standard high lift blades provides the best bagging performance.

The Toro Atomic blade is recommended for bagging leaves in dry conditions. In dry, dusty conditions, the medium lift or low lift blades reduces dust and dirt blowout while providing effective bagging air flow.

Contact an Authorized Service Dealer for the proper blades for different mowing conditions.

Curb Climbing and Loading

Always lift the deck to the highest position when loading the machine on trailers or ascending/descending a curb. Leaving the mower in a lower position while loading or going over a curb can cause damage to the mower. If a curb is higher than 152 mm (6 inches), cross it at a sharp angle with the deck fully raised. Use extreme caution when loading onto a trailer. Use a full-width ramp; the ramp should be long enough so that the angle does not exceed 15 degrees.

Maintenance

Recommended Maintenance Schedule(s)

| Maintenance Service Interval | Maintenance Procedure |
|------------------------------|--|
| After the first 8 hours | <ul style="list-style-type: none"> Inspect the blower belt. Inspect the collection system. |
| Before each use or daily | <ul style="list-style-type: none"> Clean the hood screen. Clean the collection system. |
| Every 25 hours | <ul style="list-style-type: none"> Inspect the blower belt. |
| Every 50 hours | <ul style="list-style-type: none"> Grease the idler arm. |
| Every 100 hours | <ul style="list-style-type: none"> Grease the handle pivot. Inspect the collection system. |

Cleaning the Bagger Screen

Service Interval: Before each use or daily

Clean the screen before each use (more often in wet grass).

1. Disengage the power take off (PTO) and set the parking brake.
2. Turn off the engine, remove the key, and wait for all moving parts to stop before leaving the operating position.
3. Open the bagger.
4. Clean the debris from the screen.
5. Close the bagger.

Cleaning the Collection System

Service Interval: Before each use or daily

1. Wash the inside and outside of the bagger hood, tube, and the underside of the mower. Use a mild automotive detergent to remove dirt.
2. Make sure you remove matted grass from all parts.
3. After washing all parts, let them dry thoroughly.

Note: With all parts installed, start and run the machine for a minute to assist in drying.

Inspecting the Blower Belt

Service Interval: After the first 8 hours
Every 25 hours

Check the belts for cracks, frayed edges, burn marks, or any other damage. Replace damaged belts.

Replacing the Blower Belt

1. Disengage the PTO, move the motion-control levers to the NEUTRAL-LOCKED position, and set the parking brake.
2. Stop the engine, remove the key, and wait for all moving parts to stop before leaving the operating position.
3. Pull back on the spring-loaded idler pulley to relieve the belt tension (Figure 33).
4. Remove the existing bagger belt from the mower-deck pulley and then the blower pulleys.
5. Install the new belt around the blower pulleys and the mower-deck pulley (Figure 33).

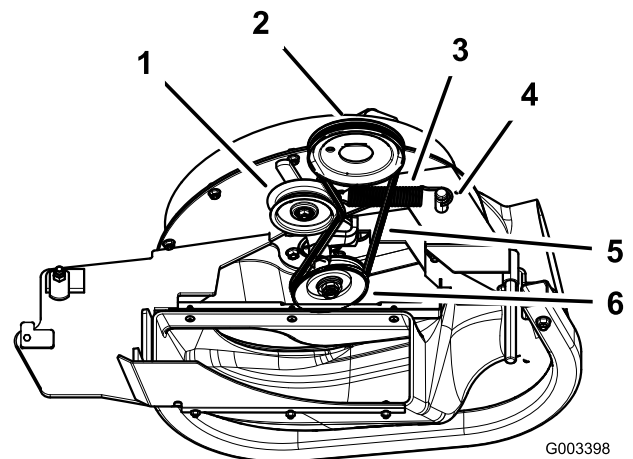

Figure 33

- | | |
|----------------------|------------------|
| 1. Idler pulley | 4. Peg |
| 2. Mower-deck pulley | 5. Belt |
| 3. Spring | 6. Blower pulley |

- Install the spring as shown in [Figure 34](#).

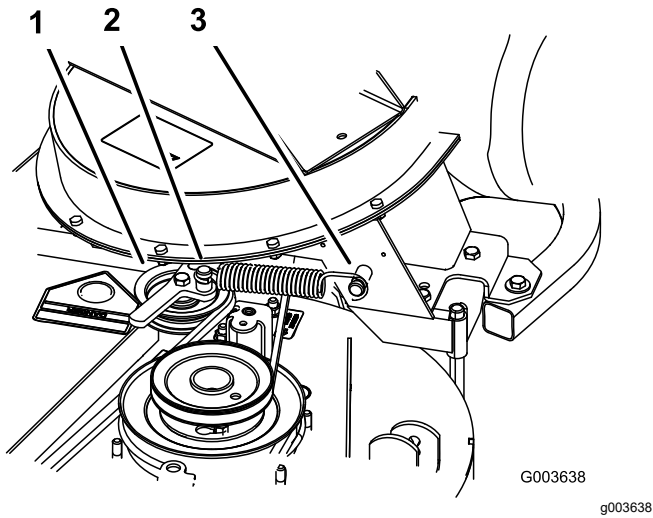

Figure 34

- Spring-loaded idler pulley
- Short-hook end
- Long-hook end

- Pull back on the spring-loaded idler pulley and install the belt onto the spring-loaded idler pulley ([Figure 33](#)).

Checking and Adjusting the Blower Latch

Close the blower assembly to see if the latches are adjusted correctly. Loosen or tighten the bolts so the latches firmly hold the blower assembly against the mower deck but can be released by hand.

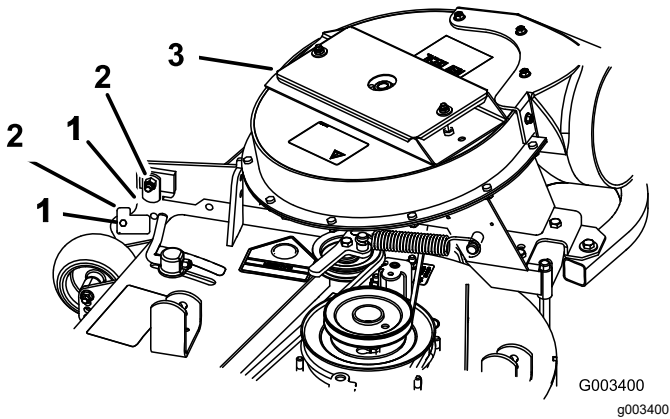

Figure 35

- Latch
- Bolt
- Blower assembly

Greasing the Idler Arm and Handle Pivot

Service Interval: Every 50 hours—Grease the idler arm.

Every 100 hours—Grease the handle pivot.

Grease the blower belt idler arm ([Figure 36](#)).

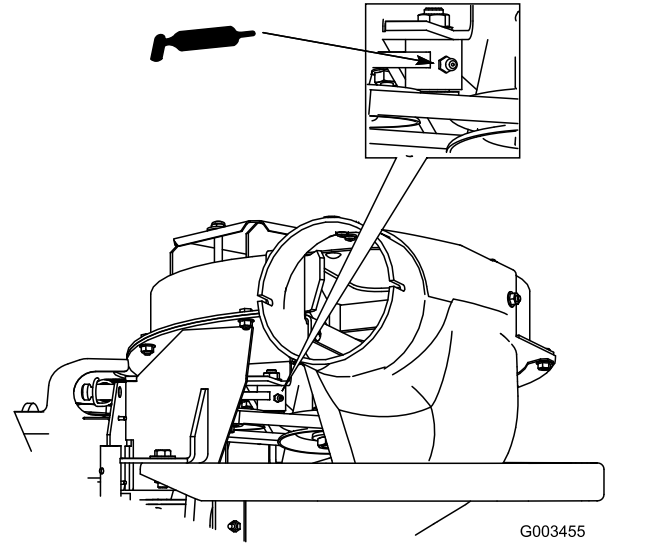

Figure 36

Grease the handle pivot ([Figure 37](#)).

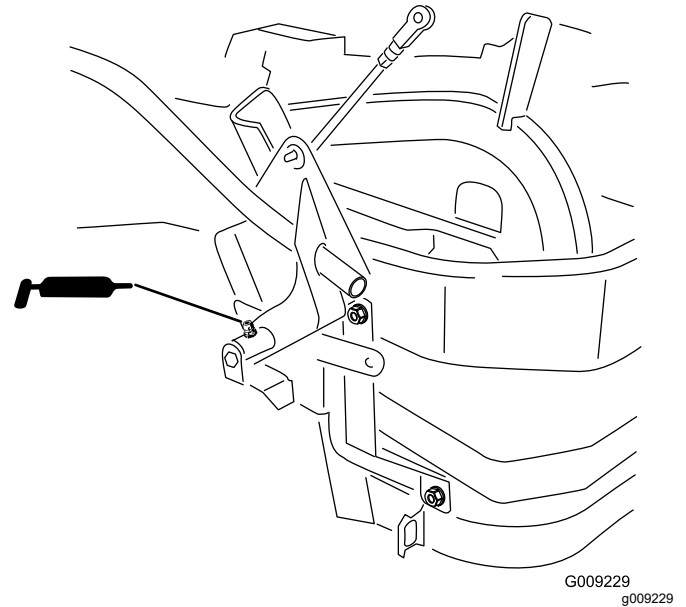

Figure 37

Inspecting the Collection System

Service Interval: After the first 8 hours

Every 100 hours

1. Disengage the PTO, move the motion-control levers to the NEUTRAL-LOCKED position, and set the parking brake.
2. Stop the engine, remove the key, and wait for all moving parts to stop before leaving the operating position.
3. Check the upper tube, lower tube, bagger, and the blower assembly.

Note: Replace these parts if they are cracked or broken.

4. Check the bagger frame.

Note: Replace any parts that are cracked or broken.

5. Tighten all nuts bolts and screws.

Adjusting the Door Closing

The two hinge links and two stop screws can be adjusted to provide complete closing of the door.

1. Disengage the PTO, move the motion-control levers to the NEUTRAL-LOCKED position, and set the parking brake.
2. Stop the engine, remove the key, and wait for all moving parts to stop before leaving the operating position.
3. With the door closed, loosen the nuts and adjust the stop bolts so that the contact arm is straight up and down (Figure 38 and Figure 39).
4. Adjust the length of the hinge links to so that the door completely closes and reasonable force is on the handle (Figure 38 and Figure 39).

Note: Lengthen the links to reduce the force. Shorten the links to increase the force

Note: Make sure that both the left and right sides are adjusted the same distance. With the door closed, the links should be slightly tight to minimize rattling.

5. Tighten the nuts.

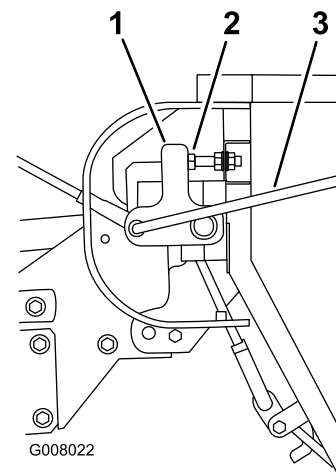

Figure 38

1. Contact arm—straight up and down
2. Stop bolt
3. Hinge links

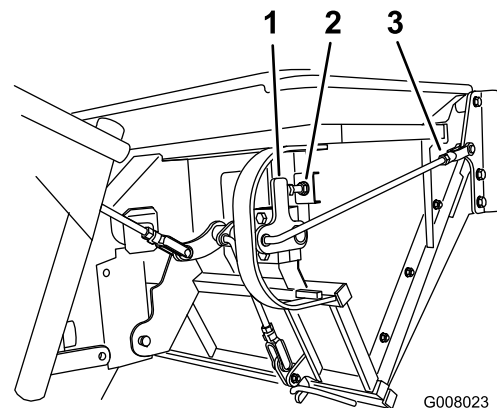

Figure 39

1. Contact arm
2. Stop bolt
3. Hinge links

Adjusting the Door Opening

Note: Perform this procedure after adjusting the door to completely close.

Adjust the handle link to so that the door opens as much as possible (Figure 40).

Note: Lengthen the handle link to open the door farther. Shorten the handle link to open the door less

Note: How far the door opens is controlled by the contact arm hitting the stop. The stop is not adjustable and prevents the door from being opened too far.

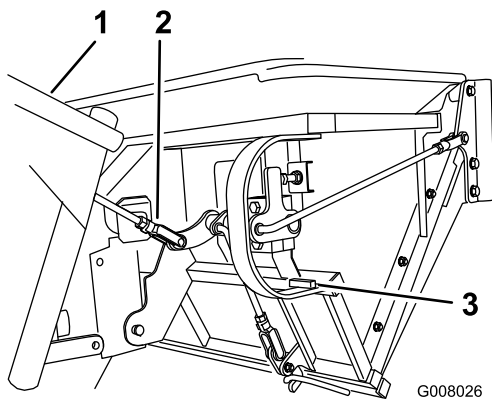

Figure 40

- 1. Handle
- 2. Handle link
- 3. Stop

Adjusting the Latches

Note: Adjust the open door and closed door positions before adjusting the latches.

1. Disengage the PTO, move the motion-control levers to the NEUTRAL-LOCKED position, and set the parking brake.
2. Stop the engine, remove the key, and wait for all moving parts to stop before leaving the operating position.
3. Close the door.
4. Ensure that the latches completely engage and contacts the latch rod welded to the door ([Figure 41](#)).

Note: The latches need to be tight against the latch rod. They need to be loose enough to move or wiggle.

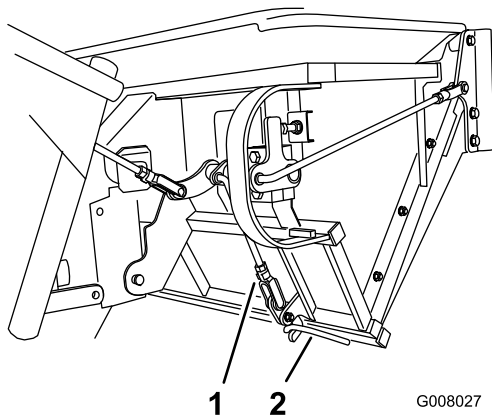

Figure 41

- 1. Latch link
- 2. Latch rod

Inspecting the Mower Blades

1. Inspect the mower blades regularly and whenever a blade strikes a foreign object.
2. If blades are badly worn or damaged, install new blades. Refer to your mower *Operator's Manual* for complete blade maintenance.

Installing the Mower Blades

In most mowing conditions, the standard high-lift blades will provide the best bagging performance.

The Toro Atomic blade is recommended for bagging leaves in dry conditions. In dry dusty conditions, the medium-lift or low-lift blades reduces dust and dirt blowout while providing effective bagging air flow.

Contact an Authorized Service Dealer for the proper blades for different mowing conditions.

Refer to the mower *Operator's Manual* for more information on installing blades.

Installing the Grass Deflector

⚠ WARNING

An uncovered discharge opening could allow the lawn mower to throw objects at you or others and result in serious injury. Also, contact with the blade could occur.

- Never operate the lawn mower unless you install a cover plate, a mulch plate, or a grass chute and catcher.
- Make sure that the grass deflector is in the down position.

1. Remove the locknut, bolt, spring and spacer holding the deflector to the pivot brackets (Figure 42).
2. Remove the damaged or worn grass deflector.
3. Place the spacer and spring onto the grass deflector.

Note: Place the **L** end of the spring behind the deck edge.

Note: Make sure that the **L** end of the spring is installed behind the deck edge before installing the bolt as shown in Figure 42

4. Install the bolt and nut.
5. Place the **J**-hook end of the spring around the grass deflector (Figure 42).

Important: The grass deflector must be able to lower down into position. Lift the deflector up to test that it lowers into the full down position.

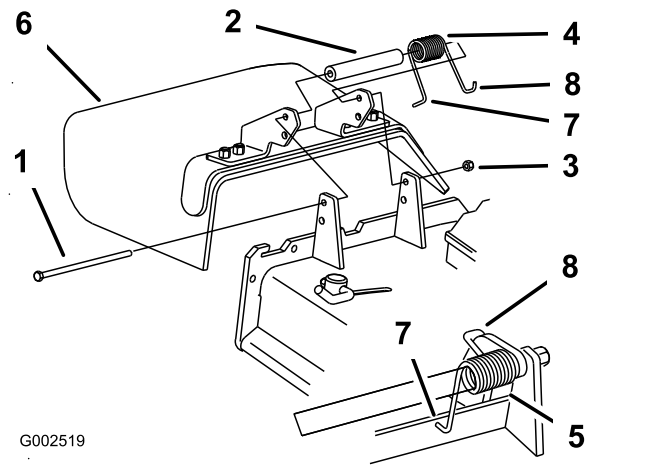

Figure 42

- | | |
|------------|--|
| 1. Bolt | 5. Spring installed |
| 2. Spacer | 6. Grass Deflector |
| 3. Locknut | 7. L end of spring, place behind deck edge before installing bolt |
| 4. Spring | 8. J -hook end of spring |

Storage

1. Clean the bagger. Refer to [Cleaning the Bagger Screen \(page 23\)](#) and [Cleaning the Collection System \(page 23\)](#).
2. Inspect the bagger for damage. Refer to [Inspecting the Collection System \(page 25\)](#).
3. Make sure that the bagger is empty and thoroughly dry.
4. Check the belt for wear or cracks.
5. Store the machine in a clean, dry place, out of direct sunlight. If you must store the machine outside, cover it with a weatherproof cover. This protects the plastic parts and extends the life of the machine.

Troubleshooting

| Problem | Possible Cause | Corrective Action |
|---|---|--|
| There is abnormal vibration. | <ol style="list-style-type: none"> 1. Cutting blade(s) is/are bent or unbalanced. 2. A blade-mounting bolt is loose. 3. A blower pulley or pulley assembly is loose. 4. A blower belt is worn. 5. Blower fan blade(s) is/are bent or unbalanced. | <ol style="list-style-type: none"> 1. Install new cutting blade(s). 2. Tighten the blade-mounting bolt. 3. Tighten the appropriate pulley. 4. Replace the blower belt. 5. Contact an Authorized Service Dealer. |
| Bagging performance is reduced. | <ol style="list-style-type: none"> 1. The engine speed is low. 2. The screen in the bagger hood is plugged. 3. A blower belt is loose. 4. A tube or blower is plugged. 5. The bagger is full. | <ol style="list-style-type: none"> 1. Always operate the collection system at full throttle. 2. Remove debris, leaves or grass clippings from the screen. 3. Replace the blower belt. 4. Locate and remove the plugged debris. 5. Empty the bagger. |
| Blower and tubes plug too frequently. | <ol style="list-style-type: none"> 1. The bagger is too full. 2. The engine speed is low. 3. Grass is too wet. 4. Grass is too long. 5. The screen in the bagger hood is plugged. 6. The ground speed is too fast. 7. A blower belt is worn. | <ol style="list-style-type: none"> 1. Dump the bagger more frequently. 2. Always operate the collection system at full throttle. 3. Cut grass when it is dry. 4. Cut no more than 51-76 mm (2-3 inches) or 1/3 of the grass height, whichever is less. 5. Remove debris, leaves or grass clippings from the screen. 6. Drive slower at full throttle. 7. Replace the blower belt. |
| Debris blow out. | <ol style="list-style-type: none"> 1. The bagger is too full. 2. The ground speed is too fast. 3. The mower deck is not level. | <ol style="list-style-type: none"> 1. Dump the bagger more frequently. 2. Drive slower at full throttle. 3. See the <i>Operator's Manual</i> for the machine for leveling the mower deck. |
| The blower impeller does not spin freely. | <ol style="list-style-type: none"> 1. The blower is plugged. 2. The impeller not aligned. | <ol style="list-style-type: none"> 1. Remove debris, leaves or grass clippings from the blower impeller. 2. Contact an Authorized Service Dealer. |

Notes:

Notes:



The Toro Total Coverage Warranty

A Limited Warranty (see warranty periods below)

Landscape
Contractor
Equipment
(LCE)

Conditions and Products Covered

The Toro Company and its affiliate, Toro Warranty Company, pursuant to an agreement between them, jointly promise to the original purchaser to repair the Toro Products listed below if defective in materials or workmanship.

The following time periods apply from the date of purchase by the original owner:

| Products | Warranty Period |
|------------------------------|---|
| 21 in. Mowers | 2 years Residential Use ¹ 1 year Commercial Use |
| • Engines ⁴ | Honda – 2 years Kawasaki – 3 years |
| 30 in. Mowers | 2 years Residential Use ¹ 1 year Commercial Use |
| • Engines ⁴ | Kawasaki – 3 years |
| Mid-Size Walk-Behind Mowers | 2 years |
| • Engines ⁴ | Kawasaki – 3 years |
| Grand Stand® Mowers | 5 years or 1,200 hours ² 3 years |
| • Engines ⁴ | Lifetime (original owner only) ³ |
| • Frame | |
| Z Master® 2000 Series Mowers | 4 years or 500 hours ² 3 years |
| • Engines ⁴ | Lifetime (original owner only) ³ |
| • Frame | |
| Z Master® 3000 Series Mowers | 5 years or 1,200 hours ² 3 years |
| • Engines ⁴ | Lifetime (original owner only) ³ |
| • Frame | |
| Z Master® 5000 Series Mowers | 5 years or 1,200 hours ² Kohler Command – 2 years Kohler EFI – 3 years |
| • Engines ⁴ | Lifetime (original owner only) ³ |
| • Frame | |
| Z Master® 6000 Series Mowers | 5 years or 1,200 hours ² Kawasaki – 3 years |
| • Engines ⁴ | Lifetime (original owner only) ³ |
| • Frame | |
| Z Master® 7000 Series Mowers | 5 years or 1,200 hours ² 2 years |
| • Engines ⁴ | Lifetime (original owner only) ³ |
| • Frame | |
| Z Master® 8000 Series Mowers | 2 years or 1,200 hours ² 2 years |
| • Engines ⁴ | Lifetime (original owner only) ³ |
| • Frame | |
| All Mowers | |
| • Battery | 90 days Parts and Labor 1 year Parts only |
| • Belts and Tires | 90 days |
| • Attachments | 1 year |

¹Residential use means use of the product on the same lot as your home. Use at more than one location is considered commercial use and the commercial warranty would apply.

²Whichever occurs first.

³Lifetime Frame Warranty - If the main frame, consisting of the parts welded together to form the tractor structure that other components such as the engine are secured to, cracks or breaks in normal use, it will be repaired or replaced, at Toro's option, under warranty at no cost for parts and labor. Frame failure due to misuse or abuse and failure or repair required due to rust or corrosion are not covered.

⁴Some engines used on Toro Products are warranted by the engine manufacturer.

Instructions for Obtaining Warranty Service

If you think that your Toro Product contains a defect in materials or workmanship, follow this procedure:

- Contact any Authorized Toro Service Dealer to arrange service at their dealership. To locate a dealer convenient to you, refer to the Yellow Pages of your telephone directory (look under "Lawn Mowers") or access our web site at www.Toro.com. You may also call the numbers listed in item #3 to use the 24-hour Toro Dealer locator system.
- Bring the product and your proof of purchase (sales receipt) to the Service Dealer. The dealer will diagnose the problem and determine if it is covered under warranty.
- If for any reason you are dissatisfied with the Service Dealer's analysis or with the assistance provided, contact us at:

RLC Customer Care Department
Toro Warranty Company
8111 Lyndale Avenue South
Bloomington, MN 55420-1196
888-865-5676 (U.S. Customers)
888-865-5691 (Canada customers)

Owner Responsibilities

You must maintain your Toro Product by following the maintenance procedures described in the *Operator's Manual*. Such routine maintenance, whether performed by a dealer or by you, is at your expense.

Items and Conditions Not Covered

There is no other express warranty except for special emission system coverage and engine warranty coverage on some products. This express warranty does not cover the following:

- Cost of regular maintenance service or parts, such as filters, fuel, lubricants, oil changes, spark plugs, air filters blade sharpening or worn blades, cable/linkage adjustments, or brake and clutch adjustments
- Components failing due to normal wear
- Any product or part which has been altered or misused or neglected and requires replacement or repair due to accidents or lack of proper maintenance
- Pickup and delivery charges
- Repairs or attempted repairs by anyone other than an Authorized Toro Service Dealer
- Repairs necessary due to failure to follow recommended fuel procedure (consult *Operator's Manual* for more details)
 - Removing contaminants from the fuel system is not covered
 - Use of old fuel (more than one month old) or fuel which contains more than 10% ethanol or more than 15% MTBE
 - Failure to drain the fuel system prior to any period of non-use over one month

General Conditions

All repairs covered by these warranties must be performed by an Authorized Toro Service Dealer using Toro approved replacement parts.

Neither The Toro Company nor Toro Warranty Company is liable for indirect, incidental or consequential damages in connection with the use of the Toro Products covered by this warranty, including any cost or expense of providing substitute equipment or service during reasonable periods of malfunction or non-use pending completion of repairs under this warranty.

All implied warranties of merchantability (that the product is fit for ordinary use) and fitness for use (that the product is fit for a particular purpose) are limited to the duration of the express warranty.

Some states do not allow exclusions of incidental or consequential damages, or limitations on how long an implied warranty lasts, so the above exclusions and limitations may not apply to you.

This warranty gives you specific legal rights, and you may also have other rights which vary from state to state.

Countries Other than the United States or Canada

Customers who have purchased Toro products outside the United States or Canada should contact their Toro Distributor (Dealer) to obtain guarantee policies for your country, province, or state. If for any reason you are dissatisfied with your Distributor's service or have difficulty obtaining guarantee information, contact the Toro importer. If all other remedies fail, you may contact us at Toro Warranty Company.

Australian Consumer Law: Australian customers will find details relating to the Australian Consumer Law either inside the box or at your local Toro Dealer.