



MODEL NO. 04356—200000001 AND UP

OPERATOR'S
MANUAL**GREENSMASTER® 3100**

To understand this product, and for safety and optimum performance, read this manual before starting operation. Pay special attention to **SAFETY INSTRUCTIONS** highlighted by this symbol.



The safety alert symbol means **CAUTION**, **WARNING** or **DANGER**—personal safety instruction. Failure to comply with the instruction may result in personal injury.



Forward

The Greensmaster 3100 was developed to provide an efficient, trouble-free and time-saving method of mowing high-quality turf on the finest greens. The latest concepts in engineering, design and safety have been incorporated into this machine, along with the highest quality parts and workmanship. This product will provide excellent service if you follow proper operation and maintenance practices.

We know, because you have purchased the industry leader in mowing excellence, that future performance and dependability are of prime importance. Therefore, this manual should be read by you and all others involved with the Greensmaster 3100 to make sure that safety, operation and maintenance procedures are followed.

Table of Contents

Forward	2	Maintenance	24
Table of Contents	2	Maintenance Schedule	24
Safety	3	Lubrication	26
Sound & Vibration Levels	5	Changing the Engine Oil and Filter	28
Symbol Glossary	6	Servicing the Air Cleaner	28
Specifications	9	Adjusting the Throttle Control	29
Set-Up	10	Adjusting the Choke Control	29
Install the Cutting Units	10	Adjusting Carburetor and Speed Control	29
Installing Cutting Units	11	Replacing Spark Plugs	30
Rear Ballast	12	Fuel Filter Replacement	30
Before Operating	13	Changing the Hydraulic Oil and Filter	31
Check the Engine Oil	13	Checking Hydraulic Hoses and Lines	31
Fill the Gas Tank	13	Brake Adjustment	32
Check the Hydraulic System	14	Rear Camshaft Adjustment	32
Tire Pressure	15	Adjusting the Lift and Mow Pedal Height	33
Check Wheel Nut Torque	15	Leveling the Lift and Mow Pedals	33
Controls	16	Adjusting the Traction Pedal	33
Operating Instructions	18	Adjusting the Cutting Unit Lift/Drop	34
Break-In Period	18	Adjusting the Lift Cylinders	35
Starting Instructions	18	Seat Switch Maintenance	35
Check the Interlock System Operation	18	Traction Switch Maintenance	35
Check the Leak Detector Operation	20	Mow/Lift Switch Maintenance	36
Preparing the Machine for Mowing	21	Adjusting the Traction Return Linkage	36
Training Period	21	Battery Care	36
Before Mowing	21	Troubleshooting	38
Mowing Procedures	21	Storage	44
Leak Detector Operation	22	Identification and Ordering	44
Transport Operation	23		
Inspection and Clean-Up After Mowing	23		

Safety

Training

1. Read the instructions carefully. Be familiar with the controls and the proper use of the equipment.
2. Never allow children or people unfamiliar with these instructions to use the lawn mower. Local regulations may restrict the age of the operator.
3. Never mow while people, especially children, or pets are nearby.
4. Keep in mind that the operator or user is responsible for accidents or hazards occurring to other people or their property.
5. Do not carry passengers.
6. All drivers should seek and obtain professional and practical instruction. Such instruction should emphasize:
 - the need for care and concentration when working with ride-on machines;
 - control of a ride-on machine sliding on a slope will not be regained by the application of the brake. The main reasons for loss of control are:
 - insufficient wheel grip;
 - being driven too fast;
 - inadequate braking;
 - the type of machine is unsuitable for its task;
 - lack of awareness of the effects of ground conditions, especially slopes;
 - incorrect hitching and load distribution.

Preparation

1. While mowing, always wear substantial footwear and long trousers. Do not operate the equipment when barefoot or wearing open sandals.
2. Thoroughly inspect the area where the equipment is to be used and remove all objects which may be thrown by the machine.
3. **WARNING—Petrol is highly flammable.**

- Store fuel in containers specifically designed for this purpose.
- Refuel outdoors only and do not smoke while refueling.
- Add fuel before starting the engine. Never remove the cap of the fuel tank or add petrol while the engine is running or when the engine is hot.
- If petrol is spilled, do not attempt to start the engine but move the machine away from the area of spillage and avoid creating any source of ignition until petrol vapors have dissipated.
- Replace all fuel tanks and container caps securely.

4. Replace faulty silencers.

Operation

1. Do not operate the engine in a confined space where dangerous carbon monoxide fumes can collect.
2. Mow only in daylight or in good artificial light.
3. Before attempting to start the engine, disengage all blade attachment clutches and shift into neutral.
4. Do not use on slopes of more than:
 - Never mow side hills over 5°
 - Never mow uphill over 10°
 - Never mow downhill over 15°
5. Remember there is no such thing as a “safe” slope. Travel on grass slopes requires particular care. To guard against overturning:
 - do not stop or start suddenly when going up or downhill;
 - engage the clutch slowly, and always keep the machine in gear, especially when travelling downhill;
 - machine speeds should be kept low on slopes and during tight turns;

- stay alert for bumps and hollows and other hidden hazards;
 - never mow across the face of the slope, unless the lawn mower is designed for this purpose.
6. Use care when pulling loads or using heavy equipment.
 - Use only approved drawbar hitch points.
 - Limit loads to those you can safely control.
 - Do not turn sharply. Use care when reversing.
 - Use counterweight(s) or wheel weights when suggested in the instruction handbook.
 7. Watch out for traffic when crossing or near roadways.
 8. Stop the blades rotating before crossing surfaces other than grass.
 9. When using any attachments, never direct discharge of material toward bystanders nor allow anyone near the machine while in operation .
 10. Never operate the lawn mower with defective guards, shields or without safety protective devices in place.
 11. Do not change the engine governor settings or overspeed the engine. Operating the engine at excessive speeds may increase the hazard of personal injury.
 12. Before leaving the operator's position:
 - Disengage the power take-off and lower the attachments;
 - Change into neutral and set the parking brake;
 - Stop the engine and remove the key.
 13. Disengage the drive to attachments when transporting or not in use.
 14. Stop the engine and disengage the drive to the attachment
 - Before refueling;
 - Before removing the grass catcher;
 - Before making height adjustments unless the adjustment can be made from the operator's position.
 - Before clearing blockages;
 - Before checking, cleaning or working on the lawnmower;
 - After striking a foreign object. Inspect the lawnmower for damage and make repairs before restarting and operating the equipment.
 15. Reduce the throttle setting during engine runout and, if the engine is provided with a shutoff valve, turn the fuel off at the conclusion of mowing.

Maintenance and Storage

1. Keep all nuts, bolts and screws tight to be sure the equipment is in safe working condition.
2. Never store the equipment with petrol in the tank inside a building where fumes may reach an open flame or spark.
3. Allow the engine to cool before storing in any enclosure.
4. To reduce the fire hazard, keep the engine, silencer, battery compartment and petrol storage area free of grass, leaves, or excessive grease.
5. Check the grass catcher frequently for wear or deterioration.
6. Replace worn or damaged parts for safety.
7. If the fuel tank has to be drained, this should be done outdoors.
8. Be careful during adjustment of the machine to prevent entrapment of the fingers between moving blades and fixed parts of the machine.
9. On multi-bladed machines, take care as rotating one blade can cause other blades to rotate.
10. When the machine is to be parked, stored or left unattended, lower the cutting means unless a positive mechanical lock is used.

Sound & Vibration Levels

Sound Levels

This unit has an equivalent continuous A-weighted sound pressure at the operator ear of: 86 dB(A), based on measurements of identical machines per 84/538/EEC.

This unit has a sound power level of 100 dB(A)/1pW, based on measurements of identical machines per procedures outlined in Directive 79/113/EEC and amendments.

Vibration Levels

This unit has a vibration level of 2.5 m/s² at the posterior, based on measurements of identical machines per ISO 2631 procedures.

This unit does not exceed a vibration level of 0.5 m/s² at the posterior based on measurements of identical machines per ISO 2631 procedures.

Symbol Glossary

Caustic liquids, chemical burns to fingers or hand	Poisonous fumes or toxic gases, asphyxiation	Electrical shock, electrocution	High pressure fluid, injection into body	High pressure spray, erosion of flesh	High pressure spray, erosion of flesh	Crushing of fingers or hand, force applied from above	Crushing of toes or foot, force applied from above

Crushing of whole body, applied from above	Crushing of torso, force applied from side	Crushing of fingers or hand, force applied from side	Crushing of leg, force applied from side	Crushing of whole body	Crushing of head, torso and arms	Cutting of fingers or hand	Cutting of foot

Cutting or entanglement of foot, rotating auger	Severing of foot, rotating knives	Severing of fingers or hand, impeller blade	Wait until all machine components have completely stopped before touching them	Severing of fingers or hand, engine fan	Whole body entanglement, implement input drive line	Fingers or hand entanglement, chain drive





Hand & arm entanglement, belt drive	Thrown or flying objects, whole body exposure	Thrown or flying objects, face exposure	Runover/backover, (relevant machine to appear in dashed box)	Machine tipping, riding mower	Machine rollover, ROPS (relevant machine to appear in dashed box)	Stored energy hazard, kickback or upward motion	Hot surfaces, burns to fingers or hands





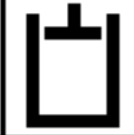

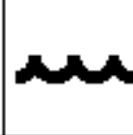
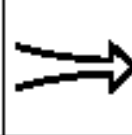

Explosion	Fire or open flame	Secure lifting cylinder with locking device before getting in hazardous area	Stay a safe distance from the machine	Stay clear of articulation area while engine is running	Do not open or remove safety shields while engine is running	Do not step on loading platform if PTO is connected to tractor & engine is running	Do not step



Shut off engine & remove key before performing maintenance or repair work	Riding on this machine is allowed only on a passenger seat & only if the driver's view is not hindered	Consult technical manual for proper service procedures	Fasten seat belts	Safety alert triangle	outline safety alert symbol	Read operator's manual





Symbol Glossary







							
Eye protection must be worn	Head protection must be worn	Hearing protection must be worn	Caution, toxic	First aid	Flush with water	Engine	Transmission



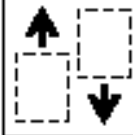



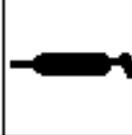

							
Fire, open light & smoking prohibited	Hydraulic system	Brake system	Oil	Coolant (water)	Inlet air	Exhaust gas	Pressure

							
Level indicator	Liquid level	Filter	Temperature	Failure/ Malfunction	Service/ lock/ mechanism	On/over	Off/stop

							
Engage	Disengage	Attachment lower	Attachment raise	Spacing distance	Spindle driver/ collector auger	Plug/ increase/ positive polarity	Minus/ decrease/ negative polarity

							
Horn	Battery charging condition	Hourmeter/ elapsed operating hours	Foot	Slow	Cap/ always variable, linear	Volume empty	Volume full

							
Machine travel direction forward/rearward	Control lever operating direction, dual direction	Control lever operating direction, multiple direction	Clockwise rotation	Counter-clockwise rotation	Grease lubrication point	Oil lubrication point	Lift point

							
Jacket or support point	Drinking/ emptying	Engine lubricating oil	Engine lubricating oil pressure	Engine lubricating oil level	Engine lubricating oil filter	Engine lubricating oil temperature	Engine coolant

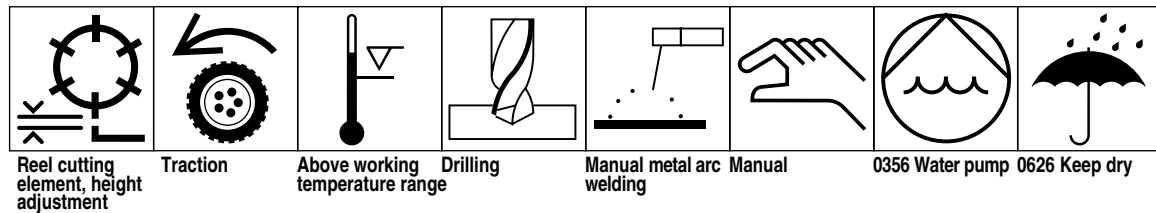
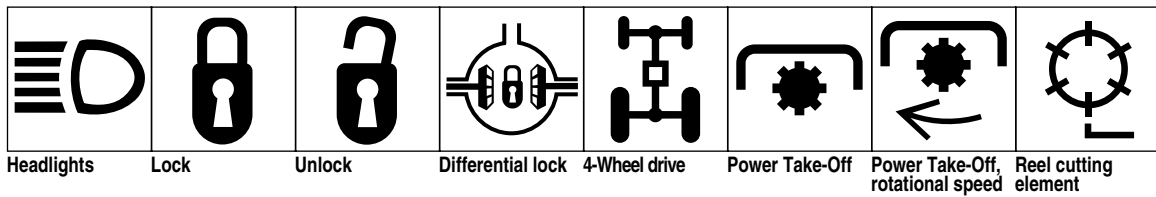
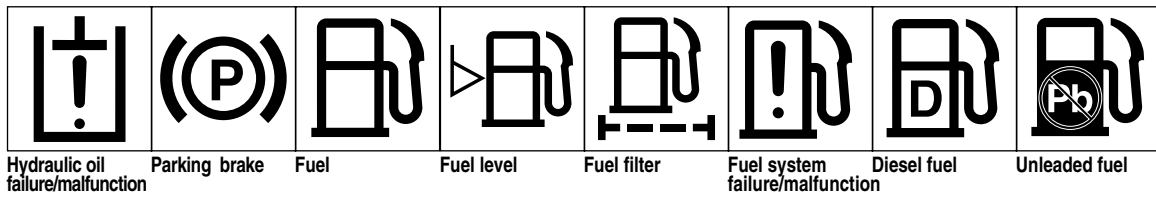
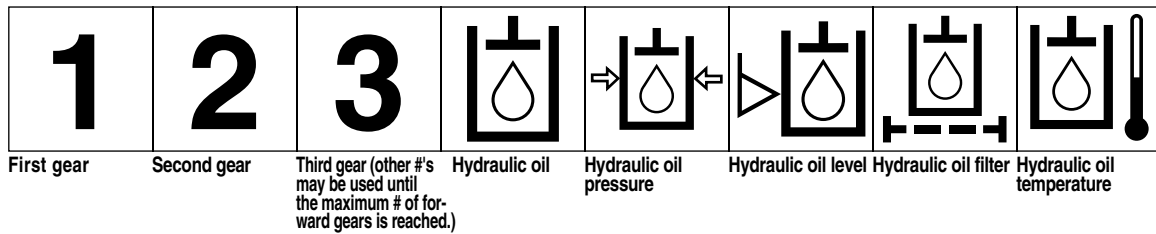
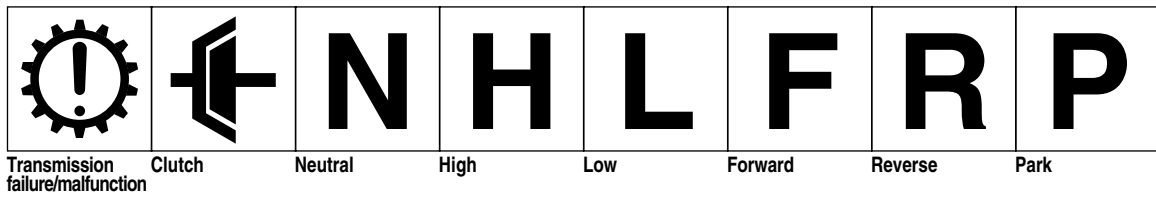
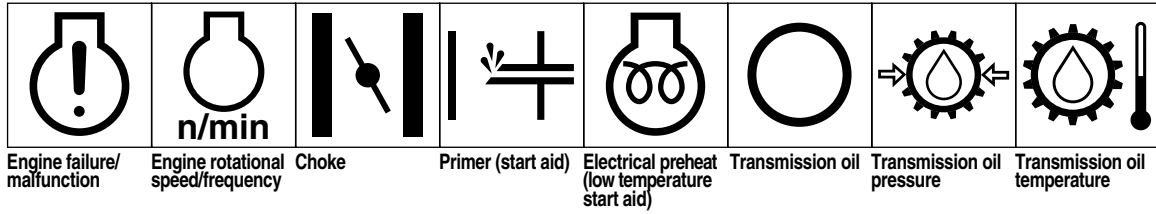
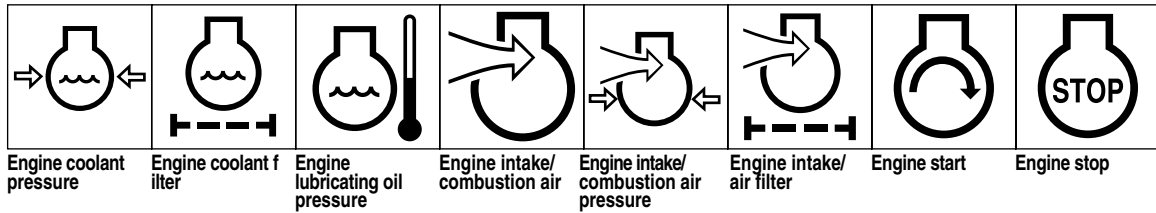

Specifications

Configuration: Tricycle vehicle with the front two wheels providing drive and the rear wheel providing steering. The operator sits in the center over the No. 1 cutting unit with the No. 2 & 3 cutting units in front of the vehicle.

Power: 4-cycle gasoline engine, electric start, with output of 13.4 kW @3,600 rpm. Maximum no-load governed engine speed is 2,900 rpm.

Traction: All-hydraulic drive, consisting of multiple stack pump valve, valve, and two orbital gear motors to drive the front wheels.

Cutting Units: All-hydraulic drive, consisting of three gear pump sections, three valve sections and three gear motors that drive the reels.

Hydraulic Valve: Five spool sections: the first 3 spool sections control the lowering, mowing and lift functions of the cutting units. The spools moved out provide lowering and MOW operation; moved in they provide LIFT operation. The number 4 spool section controls the traction functions, N (Neutral), 1 (Mow), and 2 (transport). The number 5 spool section controls forward and reverse traction.

Tire Pressure :

- 55–83 kPa—front
- 55–103 kPa—rear

Brakes: 15 cm drum-type mechanical with rack and pawl lock for parking.

Hydraulic Filter: 10-micron, cartridge type.

Hydraulic Oil Reservoir: 32.2 liter capacity with internal baffle. Type fluid: Mobil 15M. Red dye is added at the factory.

Gas Tank: 28.4 liter capacity.

Fuel Filter: In-line type.

Fuel Pump: Vacuum pulse type.

Seat Adjustment: 17.8 cm (forward and rearward).

Wheel Bearings:

Drive Wheels: Needle provided in wheel motors.
Rear Caster Wheels: Timken tapered roller

Electrical & Instrumentation: The engine contains a 18-amp alternator; the circuit is fused at 20 amps. Instruments include ammeter and hour meter. An accessory terminal is available at the leak detector test switch if attachment of headlights is desired.

Battery: 12-Volt, lead acid, 32-amp. hour. Size: Length—18.4cm, Width—12.4cm, height—15.2cm.

General Specifications:

Width of Cut:	149.9 cm
Wheel Tread:	123.3 cm
Wheel Base:	119 cm
Overall Length:	229 cm
Overall Width:	177 cm
Overall Height:	123 cm
Net Weight (Wet):	381 kg
Shipping Weight (In carton):	471 kg

Speeds:

1st —6.1 kmh
2nd—13 kmh
Rev.—3.1 kmh

Reels: 1,975 rpm (approximately)

Clip:

0.46 cm	(11-Blade Cutting Unit)
0.64 cm	(8-Blade Cutting Unit)
1.0 cm	(5-Blade Cutting Unit)

Specifications and design subject to change without notice.

Set-Up

Install the Cutting Units

For Cutting Unit Models 04404, 04406, 04408 04450 and 04468.

Note: When sharpening, setting height of cut, or performing other maintenance procedures on the cutting units, store the cutting unit reel motors in support tubes on the front of the frame to prevent damage to the hoses.

1. Remove the cutting units from their cartons. Assemble and adjust according to the operator's manual for the cutting units. Use the height gauge bar from the loose parts kit to adjust height of cut.
2. Slide the cutting units under the pull frames and position the hoop on the top of cutting units over the lift arms (Fig. 1).

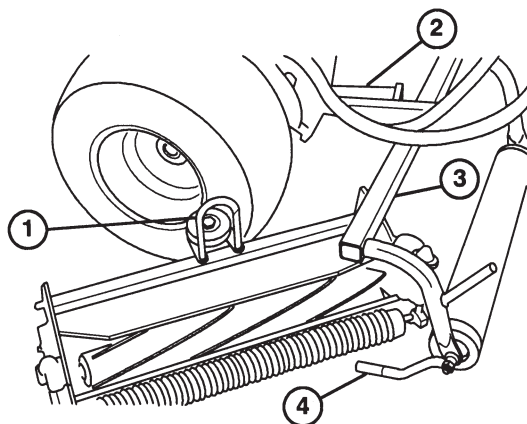

Figure 1

1. Hoop
2. Lift arm
3. Pull frame
4. Pull arm

3. Assemble the mount nuts for the reel drive motor to each cutting unit. Leave approximately 1.2cm of threads exposed on each mount stud (Fig. 2).

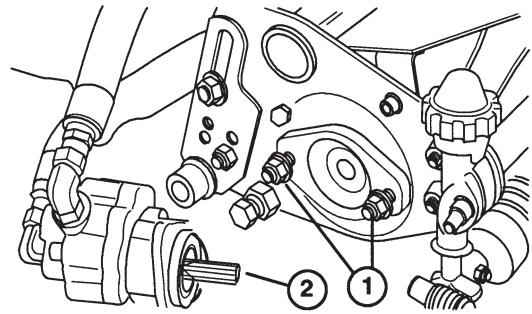

Figure 2

1. Motor mount nuts
2. Coat with grease

4. Remove the protective covers from the cutting units and the reel drive motor shafts. Coat the spline shaft of the motor with clean grease and install the motor by turning the motor clockwise so the motor flanges clear the studs. Rotate the motor counterclockwise until the flanges encircle the studs, then tighten the mounting nuts (Fig. 2).

Note: Retain the protective covers for the cutting units. Install them whenever the reel drive motors are removed to protect the cutting unit bearings from contamination.

5. Slide the sleeve back on the ball joint and rotate the pull arm down so the socket fits over the ball stud. Release the sleeve so it slides over the stud and locks the assemblies together (Fig. 4).
6. Mount the baskets on the pull frames, loosen the jam nuts on the pull arms and adjust the ball sockets until there is 6–11mm clearance between the lip of the basket and the reel blades (Fig. 3).

Note: This prevents the basket from tipping the cutting unit forward, causing the hoop to come off the lift arm while mowing.

Be sure the basket lips are equidistant from the reel blades all across each reel. If the basket is too close to the reel, it is possible for the reel to contact the basket when the cutting unit is raised off the ground.

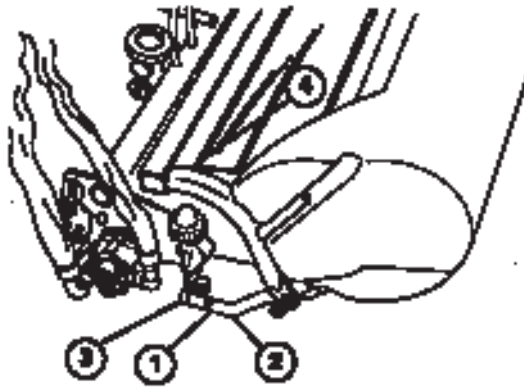

Figure 3

1. Jam nut
2. Pull arm
3. Ball joint-adjust for clearance
4. 6–11mm clearance

7. Align the sockets in the ball joints so the open side of the socket is centered toward the ball stud. Tighten the jam nuts to secure the sockets in position (Fig. 3).

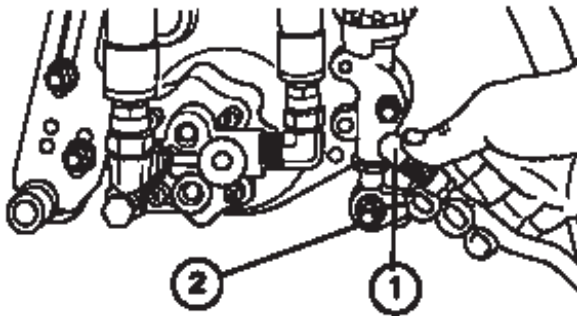

Figure 4

1. Slide back to mount
2. Ball stud

Installing Cutting Units

For Cutting Unit Models 04480, 04481, 04482, and 04483.

Note: When sharpening, setting height of cut or performing other maintenance procedures on the cutting units, store the cutting unit reel motors in support tubes on the front of the frame to prevent damage to the hoses.

1. Remove the cutting units from their cartons. Assemble and adjust according to the operator's manual for the cutting units. Use the height gauge bar from the loose parts kit to adjust height

of cut.

2. Mount a washer and ball stud to each end of the front roller on the cutting units (Fig. 5).
3. Slide the cutting unit under the pull frame while hooking the lift roller onto the lift arm (Fig. 5).

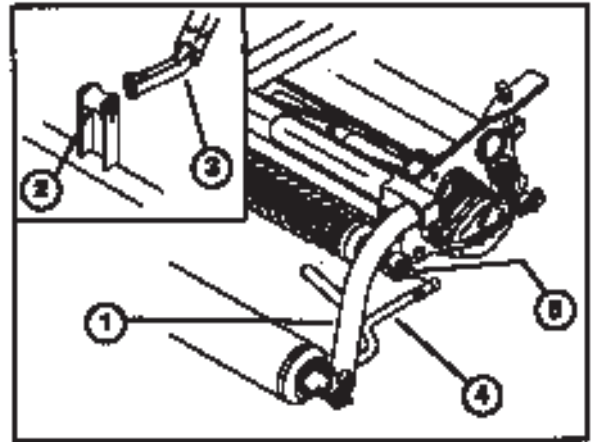

Figure 5

1. Pull frame
2. Lift roller
3. Lift arm
4. Pull arm
5. Ball stud

4. Slide the sleeve back on the ball joint and rotate the pull arm down so the socket fits over the ball stud. Release the sleeve so that it slides over the stud and locks the assemblies together (Fig. 6).
5. Mount the baskets on the pull frames, loosen the jam nuts on the pull arms and adjust the ball sockets until there is 6–11mm clearance between the lip of the basket and the reel blades or front shield.

Note: This prevents the basket from tipping the cutting unit forward causing the lift roller to come off the lift arm while mowing.

Be sure the basket lips are equidistant from the reel blades all across each reel. If the basket is too close to the reel, it's possible for the reel to contact the basket when the cutting unit is raised off the ground.

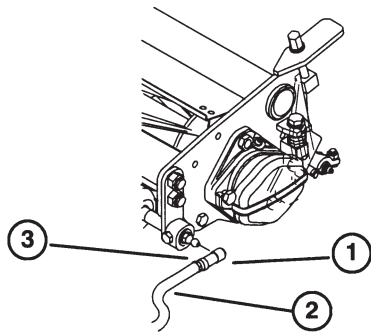

Figure 6

1. Ball joint
2. Pull arm
3. Jam nut

6. Align the sockets in the ball joints so the open side of the socket is centered toward the ball stud. Tighten the jam nuts to secure the sockets in position (Fig. 6).
7. Assemble the mounting capscrews for the reel drive motor to each cutting unit. Leave approximately 1.2cm of thread exposed on each mounting capscrew (Fig. 7).

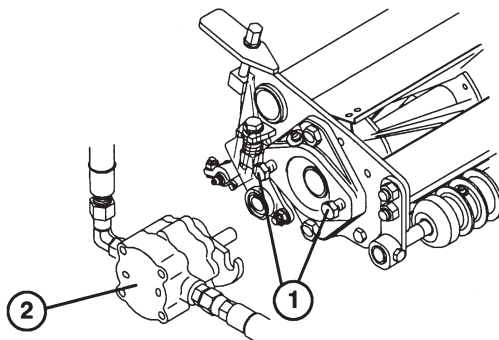

Figure 7

1. Capscrews
2. Drive motor

8. Remove the protective covers from the cutting units and the reel drive motor shafts.

Note: Retain the protective covers for the cutting units. Install them whenever the reel drive motors are removed to protect the cutting unit bearings from contamination.
9. Using a hand pump grease gun, fill the cavity at the end of the cutting unit with #2 general purpose grease.

10. Coat the spline shaft of the motor with clean grease and install the motor by rotating the motor clockwise so that the motor flanges clear the studs. Rotate the motor counterclockwise until the flanges encircle the studs, then tighten the mounting capscrews (Fig. 7).

Rear Ballast

This unit complies with the ANSI B71.4-1999 Standard when 40 lbs. of calcium chloride ballast is added to the rear wheel.

Important If a puncture occurs in a tire with calcium chloride, remove the unit from the turf area as quickly as possible. To prevent possible damage to turf, immediately soak the affected area with water.

Before Operating

Check the Engine Oil

The engine is shipped with 1.7 liter (with filter) of oil in the crankcase; however, the level of oil must be checked before and after you first start the engine.

1. Position the machine on a level surface.
2. Unscrew the dipstick and wipe it with a clean cloth. Screw the dipstick into the tube and make sure it is seated fully. Unscrew the dipstick and check the oil level. If it is low, remove the filler cap from the valve cover and add enough oil to raise the level to the FULL mark on the dipstick.

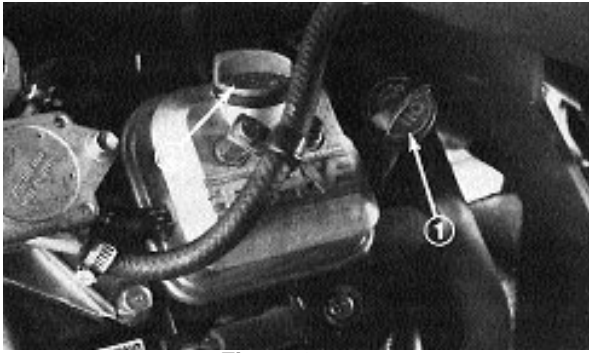

Figure 8

1. Dipstick
2. Fill Cap

3. The engine uses any high-quality detergent oil having the American Petroleum Institute — API—service classification SC, SD, SE, SF or SG. Recommended viscosity (weight) is SAE 30.
4. Pour the oil into the opening in the valve cover until the oil level is up to the FULL mark on the dipstick. Add the oil slowly and check the level often during this process. **DO NOT OVERFILL.**

Important Check the oil level every 8 operating hours or daily. Initially change the oil and filter after the first 8 hours of operation; after that—under normal conditions—change the oil after every 50 hours and the filter after every 100 hours. However, change the oil more often when you operate the engine in extremely dusty or dirty conditions.

5. Install the dipstick firmly in place.

Fill the Gas Tank



DANGER



Because gasoline is flammable, use caution when storing or handling it. Do not fill the fuel tank while the engine is running, or hot, or when the machine is in an enclosed area. Vapors may build up and be ignited by a spark or flame source many feet away. **DO NOT SMOKE** while filling the fuel tank to prevent the possibility of an explosion. Always fill the fuel tank outside and wipe up any spilled gasoline before starting the engine. Use a funnel or spout to prevent spilling gasoline before starting the engine and fill the tank to about 1 inch from the top of the tank, not the filler neck. Store gasoline in a clean safety-approved container and keep the cap in place on the container. Keep gasoline in a cool, well-ventilated place—never in an enclosed area such as a hot storage shed. To assure volatility, do not buy more than a 30-day supply of gasoline. Gasoline is a fuel for internal combustion engines; therefore, do not use it for any other purpose. Since many children like the smell of gas, keep it out of their reach because the fumes are explosive and dangerous to inhale.

THE TORO COMPANY STRONGLY RECOMMENDS THE USE OF CLEAN, FRESH UNLEADED REGULAR GASOLINE IN TORO GASOLINE-POWERED PRODUCTS. UNLEADED GASOLINE BURNS CLEANER, EXTENDS ENGINE LIFE, AND PROMOTES GOOD STARTING BY REDUCING THE BUILD-UP OF COMBUSTION CHAMBER DEPOSITS. LEADED GASOLINE CAN BE USED IF UNLEADED IS NOT AVAILABLE.

NOTE: Never use methanol, gasoline containing methanol, gasohol containing more than 10% ethanol, gasoline additives, premium gasoline, or white gas because the engine fuel system damage could result.

1. Fill the gasoline tank to the bottom of the filler neck. **DO NOT OVERFILL.** Install the cap and tighten it securely in place.



Figure 9

1. Fuel tank cap

Check the Hydraulic System

The hydraulic system is designed to operate on anti-wear hydraulic fluid. The machine's reservoir is filled at the factory with 8.5 gallons (32.2 l) of Mobil 15M hydraulic fluid. **Check the level of hydraulic fluid before the engine is first started and daily thereafter.**

Group 1 Hydraulic Fluid (Moderate climate—average duty)

Note: The fluids within this group are interchangeable.

ISO VG 46/48 multi-viscosity anti-wear hydraulic fluid

Mobil	DTE 15M
Amoco	Rykon Premium ISO 46
Castrol	AWH 46
Conoco	Hydroclear AW MV68
Gulf	Harmony HVI 46 AW
Kendall	Hyken Golden MV SAE 5W-20
Pennzbell	AWX MV46
Phillips	Magnus A KV 5W-20
Shell	Tellus T 46
Sunoco	Sun Hyd. Oil 2105
Texaco	Rando HDZ 46

Universal Tractor Hydraulic Fluid

Mobil	Mobilfluid 424
Amoco	1000 Fluid
Chevron	Tractor Hydraulic Fluid
Conoco	Hydroclear Powertran
Esso	Hydraul

Gulf	Universal Tractor Fluid
Kendall	Hyken 052
Marathon	Maraf fluid Super HT
Pennzoil	Hydra-trans
Phillips	HG Fluid
Shell	Donax TD
76 Lubricants	Hydraulic/Tractor Fluid
Sunoco	TH Fluid
Texaco	TDH

Group 2 Hydraulic Fluid (Hot Climate—Heavy Duty)

Note: The fluids within this group are interchangeable.

ISO VG 68 anti-wear hydraulic fluid

Mobil	DTE 26
Amoco	Rykon AW No. 68
Castrol	AWS 68
Chevron	Hydraulic Oil AW ISO 68
Conoco	Hydroclear AW 68
Exxon	Nuto H 68
Gulf	Harmony 68AW
Kendall	Four Seasons AW68
Marathon	ISO 68
Pennzoil	IAW Hydraulic Oil 68
Phillips	Magnus A ISO 68
Shell	Tellus 68
76 Lubricants	AW 68
Sunoco	SunVis 868
Texaco	Rando HD 68

Important Group 1 fluids are recommended for use at typical ambient temperatures of 0°C to 41°C. The ISO type 46/68 fluid has been found to offer optimal performance in a wide range of temperature conditions for the average user. The Universal Tractor Fluids offer similar performance for those who prefer them, with perhaps some slight loss of efficiency at high ambient temperatures compared with the Type 46/48 fluids

Group 2 fluids are recommended for heavy-duty use in hot climates where ambient temperatures range from about 20°C to 49°C. Use at lower ambient temperatures may result in hard starting, increased engine laboring while cold, sluggish or non-operating spool valves while cold and high

filter back-pressure due to the higher viscosity of these fluids.

Note: When changing from one type of hydraulic fluid to another, be certain to remove all the old fluid from the system because some brands are not completely compatible with other brands of hydraulic fluid.

Group 3 Hydraulic Fluid (biodegradable): ISO VG 32/46 anti-wear hydraulic fluid

Mobil

EAL 224H

Note: This biodegradable hydraulic fluid is not compatible with the fluids in groups 1 or 2

Note: When changing from standard fluid to the biodegradable type, be certain to follow approved flushing procedures as published by Mobil. Contact your local Toro distributor for details.

Important Use only types of hydraulic fluids specified. Other fluids could cause system damage.

Note: A red dye additive for the hydraulic system fluid is available in 19.8 ml bottles. One bottle is sufficient for 22 L of hydraulic fluid. Order Part No. 44-2500 from your Authorized Toro Distributor.

1. Position the machine on a level surface. Make sure the machine has cooled down so fluid is cold. Check the level of oil by viewing the sight gauge on the side of the auxiliary oil tank. If the oil level is up to the FULL mark next to the gauge, the oil level is sufficient.
2. If the oil level is below the FULL mark on the auxiliary tank, remove the cap from the hydraulic oil tank and slowly fill the tank with Mobil 15M or equivalent hydraulic oil until the level is up to the mark next to the sight gauge. Do not mix oils. Install the cap.

Important To prevent system contamination, clean the tops of hydraulic fluid containers before puncturing them. Assure the pour spout and funnel are clean.

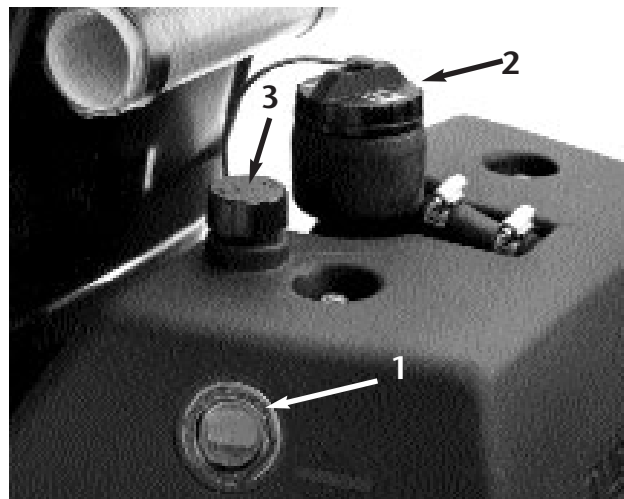

Figure 10

1. Sight gauge
2. Hydraulic tank cap
3. Auxiliary tank breather

NOTE: Make a close visual inspection of the hydraulic components. Inspect for leaks, loose fasteners, missing parts, improperly routed lines, etc. Make any corrections necessary.

Tire Pressure

The tires are over-inflated at the factory for shipping. Reduce the tire pressure to the proper levels before starting the unit.

Vary the tire pressure for the drive wheels, depending on your turf conditions, from a minimum of 55 KPa to a maximum of 83 KPa

Vary the tire pressure for the rear wheel from a minimum of 55 KPa to a maximum of 103 KPa. Traction improves with lower tire pressure.

Check Wheel Nut Torque



WARNING



Torque the wheel nuts to 95–122 N•m after one to four hours of operation and again after 10 hours of operation, then every 200 hours thereafter. Failure to maintain proper torque could result in personal injury.

Controls

MOW PEDAL (Fig. 11)—Depressing the mow pedal FULLY during operation lowers the cutting units and starts the reels. The mow pedal will stay depressed so the operator need not hold the pedal down.

BRAKE PEDAL (Fig. 11)—The brake pedal actuates an automotive drum-type mechanical brake at each traction wheel.

LIFT PEDAL (Fig. 11)—Depressing the lift pedal during operation stops the reels from turning and lifts the cutting units. The lift pedal must be FULLY depressed until the cutting units are fully raised and have stopped rotating.

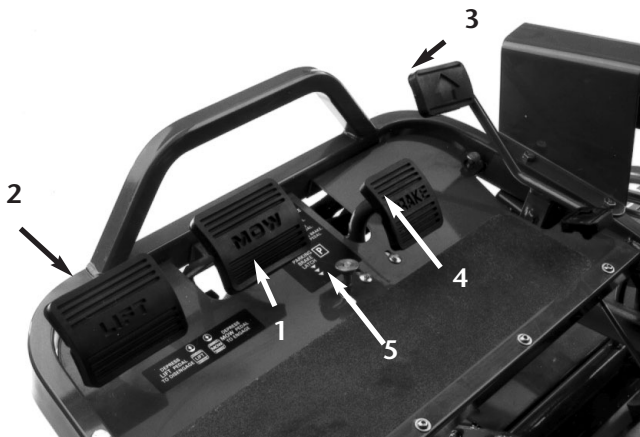

Figure 11

1. Mow pedal
2. Lift pedal
3. Traction pedal
4. Brake pedal
5. Parking brake button

PARKING BRAKE BUTTON (Fig. 11)—Depressing the brake pedal to actuate the brake assembly, then depressing the parking brake button will keep the brakes engaged for parking. Disengage by depressing the brake pedal. Form the habit of locking the parking brake before you leave the machine.

TRACTION PEDAL (Fig. 11)—The traction pedal makes the machine move forward, backward or stop. Depress the top of the pedal to move forward and the bottom of the pedal to move backward. Also, allow the pedal to move to the neutral position to stop the machine. Do not rest your heel on reverse when operating forward (Fig. 12).

THROTTLE CONTROL (Fig. 13)—The throttle controls the engine speed. Moving the throttle control toward FAST increases engine rpm; moving the throttle toward SLOW decreases engine rpm.

NOTE: You cannot stop the engine using the throttle control.

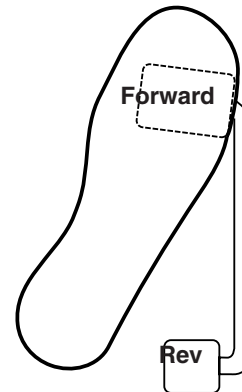

Figure 12

CHOKE (Fig. 13) —To start a cold engine, close the carburetor choke by moving the choke control forward to the CLOSED position. After the engine starts, regulate the choke to keep the engine running smoothly. As soon as possible, open the choke by pulling it rearward to OPEN. A warm engine requires little or no choking.

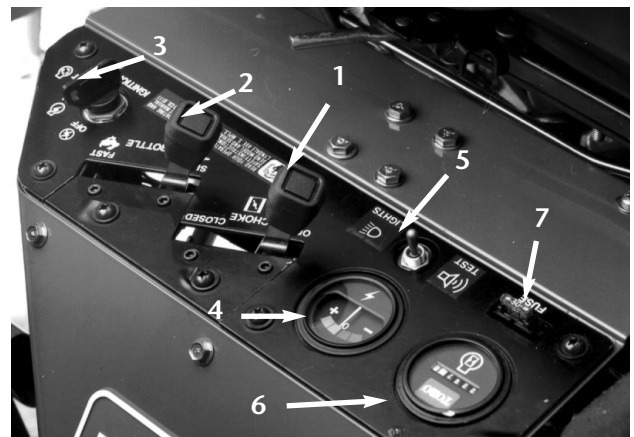

Figure 13

1. Choke control
2. Throttle control
3. Ignition switch
4. Ammeter
5. Leak detector test / light switch
6. Hour meter
7. Fuse (20 amp)

IGNITION SWITCH (Fig. 13)—Insert the key into

the switch and turn it clockwise to the **START** position to start the engine. Release the key as soon as the engine starts. Turn the key counter-clockwise to **OFF** to stop the engine

VOLTMETER (Fig. 13)—The ammeter shows the electrical system voltage.

FUSE (Fig. 13)—The 10-amp fuse is part of the electrical circuit.

LEAK DETECTOR TEST/LIGHT SWITCH (Fig. 13) From the middle operating position, move the switch rearward to check the operation of the leak detector alarm and time delay. Move the switch forward to operate optional headlights.

HOUR METER (Fig. 13)—Shows the total hours of machine operation. The hour meter starts whenever the key switch is turned to **ON**.

SEAT ADJUSTING HANDLE (Fig. 13)—Located on the left side of the seat, this lever allows four inch fore-and-aft adjustment.

MOW LOCKOUT LEVER (Fig. 14)—locks the mow pedal, preventing accidental starting of the cutting units. To unlock, pull the mow lockout pin outward, rotate it clockwise and insert the end into the rear hole in the bracket.

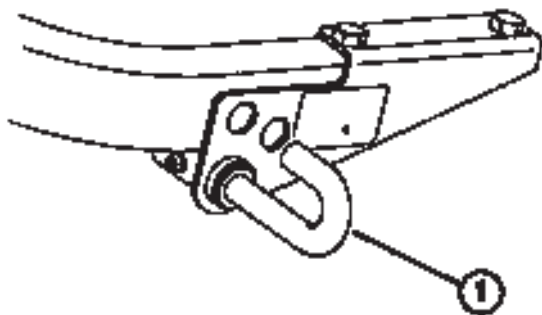

Figure 14

1. Mow lockout lever pin

SHIFT SELECTOR (Fig. 15)—Provides two traction selections, plus a **NEUTRAL** position. It is permissible to shift from one selection to another while the machine is in motion. No damage will result.

1. Neutral—Used for starting the engine.
2. No. 1 Position—Used for greens mowing operation.
3. No. 2 Position—Used for transport operation.

NOTE: If you operate the machine in reverse with the cutting units down, they will be pulled off the lift arms.

STEERING ARM LOCKING LEVER (Fig. 15)—Rotate the lever rearward to loosen, then raise or lower the steering arm for comfort. Then rotate the lever forward to tighten.

To adjust the locking lever:

1. Rotate the lever rearward to loosen adjustment and move the steering arm to its lowest position.
2. Loosen the lever set screw.
3. Rotate the adjusting bolt (left-hand thread) counter-clockwise to tighten, or clockwise to loosen the adjustment.
4. Tighten the set screw to lock the adjustment.

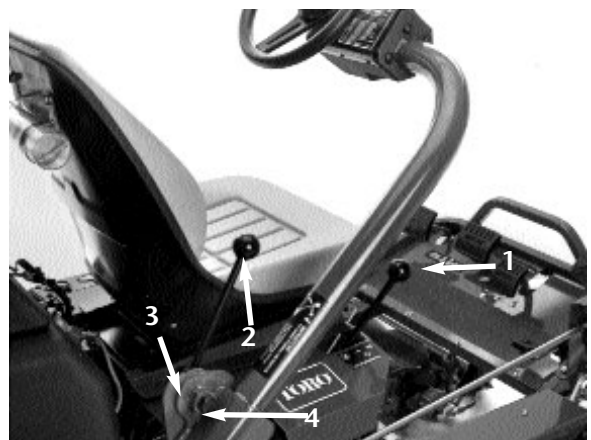

Figure 15

1. Shift selector
2. Steering arm locking lever
3. Set screw
4. Adjusting bolt

Operating Instructions

Break-In Period

1. Refer to the engine manual supplied with the Greensmaster 3100 for oil change and maintenance procedures recommended during break-in.
2. Only 8 hours of mowing operation is required for the Greensmaster 3100 break-in period.
3. The first hours of operation are critical to future dependability. Monitor performance closely so that minor difficulties that could lead to major problems can be corrected. Inspect the machine often during break-in for signs of oil leakage, loose fasteners, or any other malfunction.
4. To assure optimum performance of the brake system, burnish (break-in) the brakes before use. To burnish brakes: Firmly apply brakes and drive the machine at mowing speed until the brakes are hot, as indicated by their smell. An adjustment to the brakes may be required after break-in. Refer to Brake Adjustment.

Starting Instructions

Note: Inspect the areas beneath the mowers to make sure they are clear of debris.

1. Unlock the mow lockout lever by pulling the pin outward, rotating it clockwise and inserting the end into the rear hole in the bracket.
2. Sit on the seat, place the shift selector in NEUTRAL, and check the mow and lift pedals to make sure they are level with one another.
3. Remove your foot from the traction pedal and make sure the pedal is in neutral.
4. Move the choke lever to ON—when starting a cold engine—and the throttle lever to the half-throttle position.
5. Insert and turn the ignition key clockwise until the engine starts. After the engine starts, regulate the choke to keep the engine running smoothly. As soon as possible, open the choke by pulling it rearward to the OFF position. A warm engine requires little or no choking.

6. Check the machine out with the following procedures after the engine has started:
 - A. Move the throttle control to FAST and momentarily engage the reels by depressing the mow pedal (the cutting units should drop and all reels should turn).
 - B. Operate the lift pedal; the cutting reels should stop and the cutting units raise to full transport position.

NOTE: Stop the engine. Check the lip of each basket to be sure it doesn't contact the reel during operation. Re-adjust if the basket does make contact.
 - C. Depress the brake pedal to keep the machine from moving and operate the traction pedal through the forward and reverse positions. Continue the above procedure for 1–2 minutes.
 - D. Neutralize the traction lever and the mow and lift pedals, lock the parking brake, and turn the engine off. Check for oil leaks; if oil leaks appear, check the tightness of the hydraulic fittings. If oil leaks continue to appear, contact your local TORO dealer for assistance and, if necessary, replacement parts.

Important The motor or wheel seals may show some trace of oil for a short period of time until the break-in period is completed.

NOTE: When the Greensmaster 3100 is new and the bearings and reels are tight, it is necessary to use the FAST throttle control position for this check. A fast throttle setting may not be required after break-in.

Check the Interlock System Operation

The interlock system prevents the engine from cranking or starting unless the operator is on the seat, the shift selector is in NEUTRAL and the cutting units are DISENGAGED. Also, the engine will stop when the cutting units are engaged or if the shift selector is in the No. 1 or No. 2 position with operator off the seat. Do the following system checks daily to make

sure the interlock system operates correctly.



CAUTION



The interlock switches are for the operator's protection, so do not disconnect them. Check switch operation daily to assure the interlock system is operating. If a switch is defective, replace it before operating. Regardless of whether the switches are operating properly, replace them every two years to assure maximum safety. Do not rely entirely on safety switches—use common sense!

1. Sit on the seat, engage the parking brake, move the shift selector to neutral, remove your foot from the traction pedal and make sure the pedal is in neutral, and depress the lift pedal and release it. Try to start the engine. The engine should crank and run, which means the interlock system is operating correctly. If the engine did not crank, go to step 2. If the engine cranked, contact your local TORO dealer for assistance.
2. Sit on the seat, engage the parking brake and depress the lift pedal fully and release it. Move the shift selector to the #1 and #2 positions while trying to start the engine in each position. The engine should not crank, which means the traction switch on the valve bank is operating correctly. If the engine did not crank, go to step 3. If the engine cranked, contact your local TORO dealer for assistance.
3. Sit on the seat, engage the parking brake, depress the lift pedal and release it. Move the shift selector to Neutral and try to start the engine. The engine should start and continue to run, which means the traction switch and the mow/lift switch on valve bank are operating correctly—go to step 4. If the engine cranked but did not start, the problem is not in the interlock system. If the engine did not crank, contact your local TORO dealer for assistance.
4. Sit on the seat, engage the parking brake and move the shift selector to neutral. Depress the mow pedal and try to start the engine. The engine should not crank, which means the mow-lift switch is operating correctly. If the engine did not crank, go to step 5. If the engine cranked, ask your local TORO dealer for

assistance.

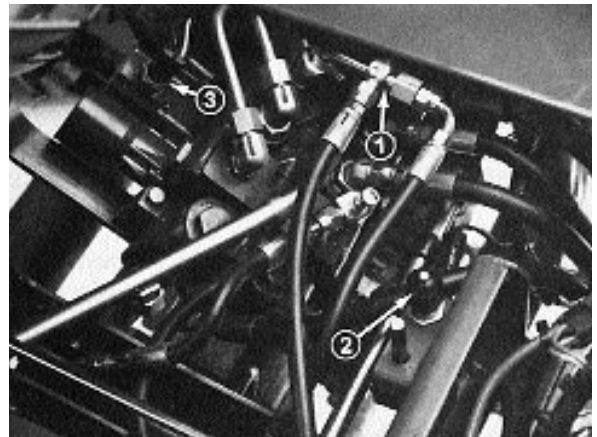

Figure 16

1. Traction switch
2. Seat switch
3. Mow/lift switch

5. Sit on the seat, move the shift selector to neutral, depress the lift pedal and release it. Start the engine and depress the mow pedal. Carefully rise off the seat; the engine should stop. If the engine stops, the interlock system is operating correctly. If the engine does not stop, stop the engine and find the problem before operating the machine again. If you need assistance, contact your local TORO distributor.
6. Sit on the seat, move the traction shift selector to neutral, fully depress the lift pedal and release it. Start the engine and drive to an open area that is free of debris and foreign objects. Keep all people, especially children, away from the front of the machine and out of the area of operation. Move the shift selector to neutral, make sure the mow pedal is disengaged, set the throttle control at half speed and engage the parking brake. (Do not engage the parking brake button.) Hold the steering wheel, brace your feet on the foot deck and brake pedal, and move the shift selector to the #1 position. Carefully rise off the seat; the engine should stop. If the engine stops, the interlock system is operating correctly.
7. Repeat this check with the shift selector in the #2 position. If the engine does not stop, stop the engine and find the problem before operating the machine. If you need assistance, contact your local TORO dealer.

Note: The Greensmaster 3100 is equipped with an interlock switch on the parking brake. The

engine will stop if the traction shift selector is in #1 or #2 positions with the parking brake engaged.

Check the Leak Detector Operation

The TURF GUARDIAN™ leak detector detects hydraulic oil system leaks. If the oil level in the main hydraulic reservoir is lowered by 12–18 cl, the float switch in the tank will close. After a 1-second delay, the alarm will sound. Expansion of oil, due to normal heating during machine operation, will cause oil to transfer into the auxiliary oil reservoir. The oil is allowed to return to the main tank when the ignition switch is turned off.

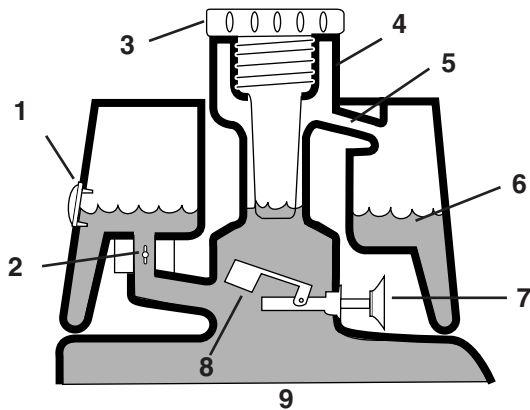

Figure 17
BEFORE START (cold oil)

1. Sight window
2. Solenoid return valve open
3. Filler cap
4. Filler neck
5. Overflow tube
6. Fluid level (cold)
7. No sound
8. Float raised, switch open
9. Hydraulic oil tank

To check system operation

1. With the ignition switch in the ON position, move the leak detector switch rearward and hold. After the one-second time delay elapses, the alarm should sound.
2. Release leak detector switch.

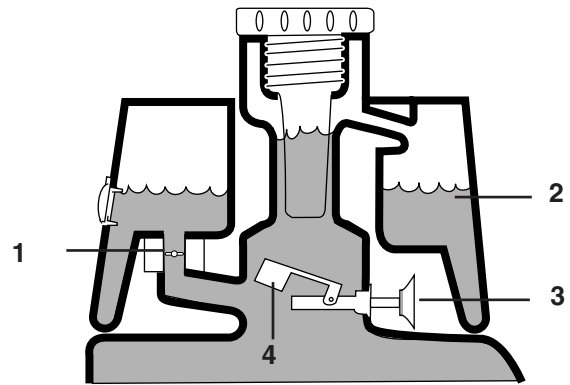

Figure 18

NORMAL OPERATION (oil warm)

1. Solenoid return valve closed
2. Fluid level (warm)
3. No sound
4. Float raised, switch open

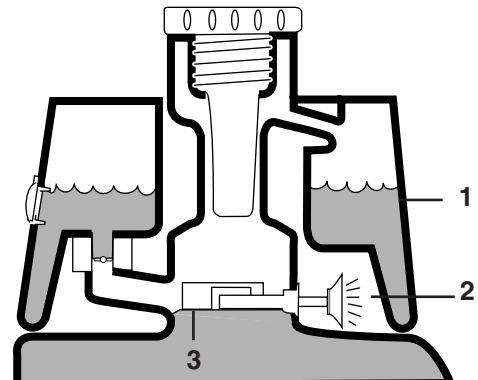

Figure 19

LEAK ALERT!

1. Fluid level (warm)
2. Warning buzzer
3. Float down, switch closed

To check leak detector system operation

1. Move the ignition switch to ON. DO NOT START THE ENGINE.
2. Remove the hydraulic tank cap and strainer from the neck of the tank.
3. Insert a clean rod or screw driver into the tank neck and gently push down on the switch float (Fig. 20). The alarm should sound after a one-second delay.
4. Release the float; the alarm should stop.

5. Install the strainer screen and the hydraulic tank cap. Move the ignition switch to OFF.

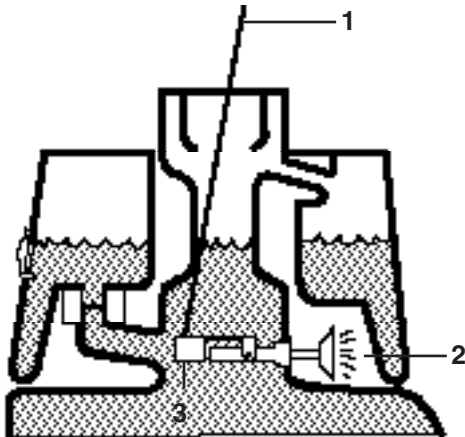

Figure 20

1. Clean the rod or screwdriver
2. Warning buzzer
3. Press down on the switch float

Preparing the Machine for Mowing

To help align the machine for successive cutting passes, do the following to the No. 2 and No. 3 cutting-unit baskets:

1. Measure in approximately 12 cm from the outer edge of each basket.
2. Either place a strip of white tape or paint a line onto each basket paralleling the outer edge of each basket (Fig. 21).

Training Period

Before mowing greens with the Greensmaster 3100, we suggest that you find a clear area and practice starting and stopping, raising and lowering the cutting units, turning, etc. This will help you gain confidence in the performance of the Greensmaster 3100.

Important If you shift to the No. 2 position while cutting greens, no increase in speed will result. However, a sudden increase in speed will develop when you actuate the lift pedal. For safety, use only the No. 1 position for cutting greens and the No. 2 position for transport.

Before Mowing

Inspect the green for debris, remove the flag from the cup, and determine the best direction in which to mow. Base the direction to mow on the previous mowing direction. Always mow in an alternate pattern from the previous mowing, so that the grass blades will be less apt to lay down and become difficult to trap between the reel blades and bedknife.

Mowing Procedures

1. Approach the green with the shift selector in the number 1 position. Start on one edge of the green so the ribbon procedure of cutting may be used. This holds compaction to a minimum and leaves a neat, attractive pattern on the greens.

Important Shift to the No. 1 position when approaching a green because machine speed will automatically be reduced when the cutting units are engaged. Higher speed will resume when the cutting units are disengaged.

2. Actuate the mow pedal as the front edge of the grass baskets cross the outer edge of the green. This procedure drops the cutting units to the turf and starts the reels.

NOTE: The No. 1 (rear) cutting unit reel will not start until all the cutting units are on the ground and No. 2 and No. 3 cutting units are cutting.

Important Remember that the No. 1 cutting unit reel is delayed and therefore, you should practice to gain the timing necessary to minimize the clean-up mowing operation.

3. Overlap a minimal amount with the previous cut on return passes. To maintain a straight line across the green and keep the machine an equal distance from the edge of the previous cut, establish an imaginary sight line 2 to 3 meters ahead of the machine to the edge of the uncut portion of the green (Fig. 21). Some people find it useful to include the outer edge of the steering wheel as part of the sight line; i.e., keep the steering wheel edge aligned with a point that is always kept the same distance away from the front of the machine (Fig. 21).

4. As the front of the baskets cross the edge of the green, depress the lift pedal. This will stop the reels and lift the cutting units. Timing of this procedure is important, so the mowers do not cut into the fringe area. However, as much of the green as possible should be cut to minimize the amount of grass left to mow around the outer periphery.
5. Cut down on operating time and ease line-up for the next pass by momentarily turning the machine in the opposite direction, then turning in the direction of the uncut portion; i.e., if intending to turn right, first swing slightly left, then right. This will help get the machine more quickly aligned for the next pass. Follow the same procedure for turning in the opposite direction. It's good practice to try to make as short a turn as possible. However, turn in a wider arc during warmer weather to avoid bruising the turf.

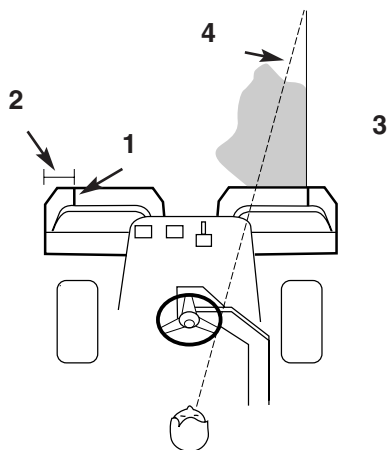

Figure 21

1. Alignment strip
2. Approximately 12 cm
3. Cut grass on right
4. Keep focal spot 2–3 meters ahead of the machine

NOTE: Due to the nature of the power steering system, the steering wheel will not return to its original position after a turn has been completed.

Important Never stop on a green with the cutting unit reels operating because you may damage the turf. Stopping on a wet green with the Greens–master 3100 may leave marks or indentations from the wheels.

6. If the leak detector alarm sounds while cutting on a green, immediately raise the cutting units, drive directly off the green and stop the machine in a

area away from the green. Find out what caused the alarm and correct the problem.

Important Prolonged idling of the machine after heavy use may cause a false alarm in the leak detector system, due to oil contraction as it cools. If this occurs, turn the engine off for a minute while the main hydraulic tank is refilled from the auxiliary tank.

7. Finish cutting the green by mowing the outer periphery. Be sure to change the direction of cutting from the previous mowing. Always keep weather and turf conditions in mind and be sure to change the direction of mowing from the previous cutting. Replace the flag.
8. Empty the grass baskets of all clippings before transporting to the next green. Heavy wet clippings place an undue strain on the baskets and will add unnecessary weight to the machine, thereby increasing the load on the engine, hydraulic system, brakes, etc.

Leak Detector Operation

The leak detector alarm may sound for one of the following reasons:

1. A leak has occurred.
 2. The oil level in the main reservoir is reduced by 12–18cl due to oil contraction from cooling.
- If the alarm sounds, turn it off as quickly as possible and inspect for leaks. If the alarm sounds while operating on a green, drive off the green first. Determine the source of the leak and repair it before continuing operation. If a leak is not found and a false leak is suspected, move the ignition switch to OFF and let the machine stand for 1–2 minutes to allow the oil levels to stabilize. Then start the machine and operate in a non-sensitive area to confirm that no leak exists.

False alarms due to oil contraction may be caused by extended idling after normal operation. A false alarm may also occur if the machine is worked at a reduced work load after an extended period of heavier work. To avoid false alarms, turn the machine off rather than letting it idle for extended periods.

Transport Operation

Make sure the cutting units are in the highest UP position. Set the shift selector in No. 2 if conditions will permit faster ground speed. In rough or hilly areas, shift to No. 1 and operate at slower ground speeds. Use the brakes to slow the machine while going down steep hills to avoid loss of control. Always approach rough areas at a reduced speed (shift selector in No. 1), and cross severe undulations carefully. Familiarize yourself with the width of the machine. Do not attempt to pass between objects that are close together so that you can prevent costly damage and down time.

Inspection and Clean-Up After Mowing

After mowing, thoroughly wash the machine. Use a garden hose without a nozzle so excessive water pressure doesn't contaminate and damage seals and bearings. After cleaning, inspect the machine for possible hydraulic fluid leaks, damage or wear to the hydraulic and mechanical components. Also check the cutting units for sharpness. Lubricate the mow and lift pedal and the brake shaft assembly with SAE 30 oil or spray lubricant to deter corrosion and keep the machine performing well during the next mowing operation.

Maintenance

Maintenance Schedule

Maintenance Procedure	Maintenance Interval & Service			
Check battery fluid level Check battery cable connections Service the air filter pre-cleaner Lubricate all grease fittings †Change the engine oil	Every 50 hours	Every 100 hours	Every 200 hours	Every 800 hours
†Replace the engine oil filter Replace the air filter element				
Check the reel bearing preload adjustment Torque the wheel lug nuts				
Replace the spark plugs Replace the fuel filter Check valve clearance Check the engine RPM (idle and full throttle)				

† Initial break in at 8 hours

Replace moving hoses Replace safety switches Fuel tank—drain and flush Hydraulic tank—drain and flush Replace the hydraulic oil	Recommendations Items are recommended every 2000 hours or 2 years, whichever occurs first.
---	--

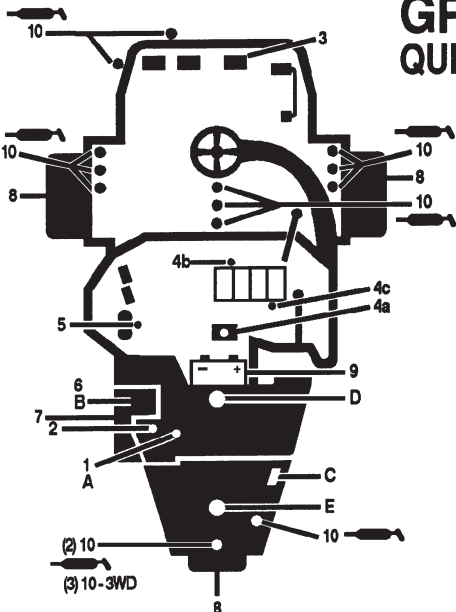

GREENSMaster 3100

QUICK REFERENCE AID



SEE OPERATOR'S MANUAL

CHECK/SERVICE (daily)

1. OIL LEVEL, ENGINE
2. OIL LEVEL, HYDRAULIC TANK
3. BRAKE FUNCTION
4. INTERLOCK SYSTEM:
 - 4a. SEAT INTERLOCK
 - 4b. MOW - LIFT INTERLOCK
 - 4c. TRACTION INTERLOCK
5. LEAK DETECTOR ALARM
6. AIR FILTER & PRECLEANER
7. ENGINE COOLING FINS
8. TIRE PRESSURE
(8 - 12 psi front, 8 - 15 psi rear)
- WHEEL NUT TORQUE (40-50 FT-LBS.)
9. BATTERY
10. LUBRICATION 

FLUID SPECIFICATIONS / CHANGE INTERVALS

See operator's manual for initial change	FLUID TYPE	CAPACITY	CHANGE INTERVALS		FILTER PART NO.
			FLUID	FILTER	
A. ENGINE OIL	SAE 30 SG	*1.7 l	50 HRS.	100 HRS.	491056
B. AIR CLEANER	—	—	—	100 HRS.	394018
C. FUEL FILTER	—	—	—	1000 HRS.	83-1320
D. HYDRAULIC OIL	MOBIL DTE 15M	28.4 l	2000 HRS.	2000 HRS.	68-9880
E. FUEL TANK	UNLEADED GAS	32.2 l	—	—	—

*including filter

94-9036

Daily Maintenance Checklist

- ✓ Safety Interlock Operation
- ✓ Brake Operation
- ✓ Engine Oil & Fuel Level
- ✓ Cooling system Fluid Level
- ✓ Radiator & Screen for Debris
- ✓ Unusual Engine Noises
- ✓ Unusual Operating Noises
- ✓ Hydraulic System Oil Level
- ✓ Hydraulic Hoses for Damage
- ✓ Fluid Leaks
- ✓ Tire Pressure
- ✓ Instrument Operations
- ✓ Lubricate All Grease Fittings
- ✓ Touch-up Damaged Paint

Lubrication

Before servicing or making adjustments to the machine, stop the engine and remove the key from the switch.

The traction unit has grease fittings that must be lubricated regularly with No. 2 General Purpose Lithium Base Grease. If the machine is operated under normal conditions, lubricate all bearings and bushings after every 50 hours of operation.

The traction unit bearings and bushings that must be lubricated are: Rear wheel roller clutches and external ball bearing (1) (Fig. 22), Steering fork shaft (1) (Fig. 23), Lift arm pivot (3), Pivot hinge (3) (Fig. 24), Pull frame shaft and roller (12) (Fig. 25), Power steering cylinder (1) (Fig. 26), Mow lift pivot (1) (Fig. 27), Lift cylinders (3) (Fig. 28) and Mow lockout lever (Fig. 29).

1. Wipe grease fittings clean so foreign matter cannot be forced into the bearing or bushing.
2. Pump grease into the bearing or bushing.
3. Wipe up excess grease.
4. Apply grease to the reel motor spline shaft and onto the lift arm when the cutting unit is removed for service.
5. Apply a few drops of SAE 30 engine oil or spray lubricant (WD 40) to all pivot points daily after cleaning.



Figure 22

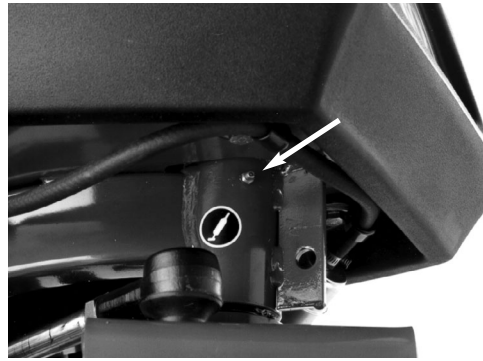

Figure 23

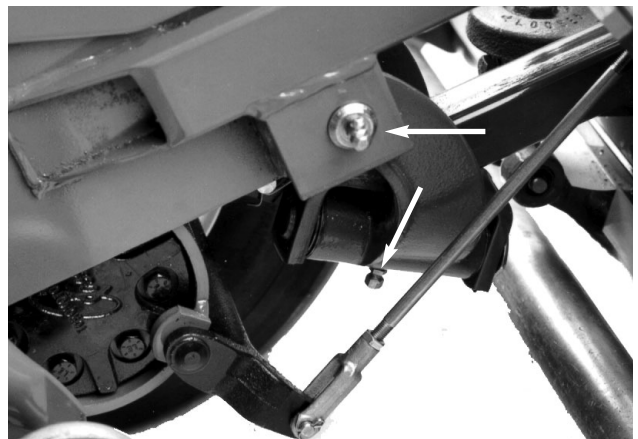

Figure 24



Figure 25



Figure 26

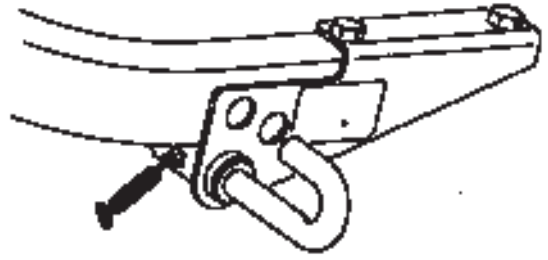

Figure 29



Figure 27

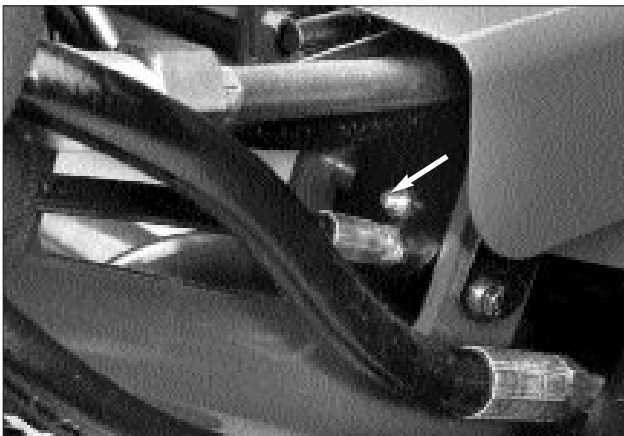

Figure 28



CAUTION



Before servicing or making adjustments to the machine, stop the engine and remove the key from the switch.

Changing the Engine Oil and Filter

Change the oil and filter initially after the first 8 hours of operation, thereafter change the oil every 50 hours and the filter every 100 hours.

1. Remove the drain plug and let oil flow into a drain pan. When oil stops flowing, install the drain plug.

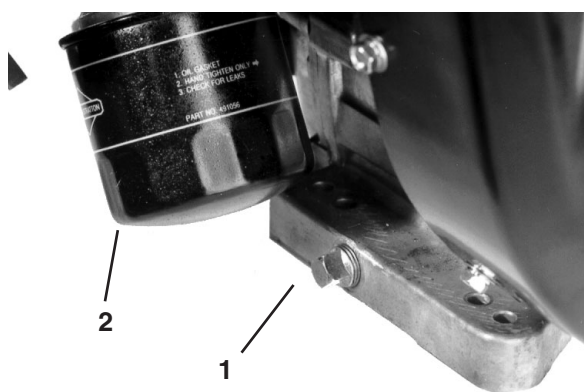

Figure 30

1. Drain plug
2. Oil filter

2. Remove the oil filter. Apply a light coat of clean oil to the new filter gasket.
3. Screw the filter on by hand until the gasket contacts the filter adapter, then tighten 1/2 to 3/4 turn further. **DO NOT OVER-TIGHTEN.**
4. Add oil to the crankcase, refer to CHECK ENGINE OIL.
5. Dispose of oil properly.

Servicing the Air Cleaner

Service the air cleaner foam pre-cleaner after every 50 operating hours and the air cleaner cartridge after every 100 operating hours. More frequent cleaning is required when operating in dusty or dirty conditions.

1. Release the locking clips and remove the air cleaner cover. Clean the cover thoroughly.



Figure 31

1. Air cleaner cover

2. Remove the wing nut securing the elements to the air cleaner body.
3. If the foam element is dirty, remove it from the paper element. Clean thoroughly.



Figure 32

1. Foam element
2. Paper element

- A. **WASH** the foam element in a solution of liquid soap and warm water. Squeeze to remove dirt, but do not twist because the foam may tear.
- B. **DRY** by wrapping the element in a clean cloth. Squeeze the cloth and foam element to dry.

C. SATURATE the element with clean engine oil. Squeeze the element to remove excess oil and to distribute oil thoroughly. An oil damp element is desirable.

4. When servicing the foam element, check the condition of the paper element. Clean by gently tapping on a flat surface or replace as required.
5. Reinstall the foam element, paper element and the air cleaner cover.

Important Do not operate the engine without the air cleaner element because extreme engine wear and damage will likely result.

Adjusting the Throttle Control

Proper throttle operation depends on proper throttle control adjustment. Before adjusting the carburetor, assure the throttle control is operating properly.

1. Loosen the cable clamp screw securing the cable to the engine.
2. Move the remote throttle control lever forward to the FAST position.
3. Pull firmly on the throttle cable until the back of the swivel contacts stop.

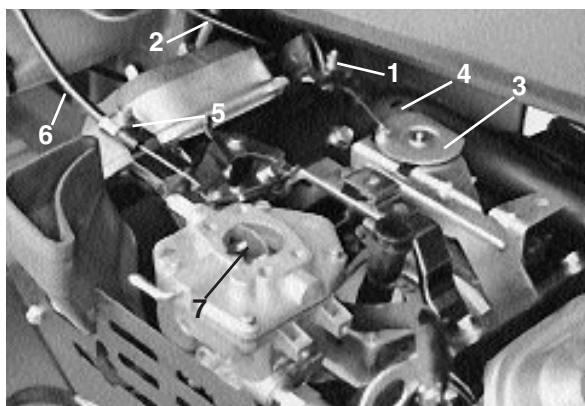

Figure 33

1. Throttle casing clamp screw
2. Throttle cable
3. Swivel
4. Stop
5. Choke casing clamp screw
6. Choke cable
7. Choke butterfly

4. Tighten the cable clamp screw and check the

engine RPM setting.

High Idle: 2850 ± 50 rpm

Low Idle: 1400 ± 50 rpm

Adjusting the Choke Control

1. Loosen the cable clamp screw securing the cable to the engine.
2. Move the remote choke control lever forward to the CLOSED position.
3. Pull firmly on the choke cable until the choke butterfly is completely closed, then tighten the cable clamp screw.

Adjusting Carburetor and Speed Control

Important Before the carburetor and speed control are adjusted, the throttle and choke controls must be adjusted properly.

The engine must be running during adjustment of the carburetor and speed control. To guard against possible personal injury, shift into neutral, and engage the parking brake. Keep your hands, feet, face, and other parts of your body away from the cutter blades and any rotating engine parts.

1. Start the engine and let it run at half throttle for approximately five minutes to warm up.

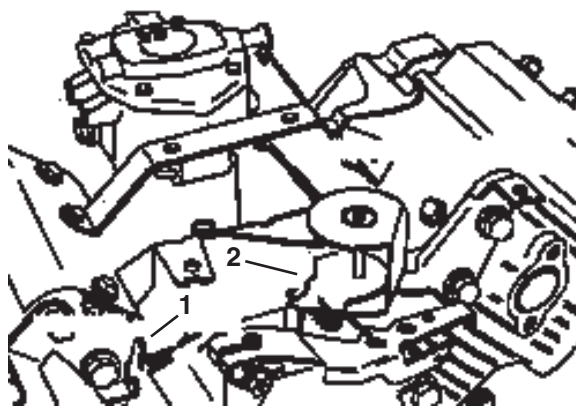

Figure 34

1. Governed idle spring anchor tang
2. High-speed spring anchor tang

2. Move the throttle control to the SLOW setting. Hold the governor lever so that the throttle lever is in the idle position (against idle stop screw) and adjust the idle stop screw to 1400 ± 50 rpm by turning the screw in or out. Check speed with a tachometer.
3. Turn the idle mixture screw slowly clockwise (lean mixture) until the engine speed just starts to decrease. Note the position of the needle.

Now turn the idle mixture screw slowly counterclockwise (rich mixture) until the engine speed just starts to decrease. Note the position of the needle.

Set the screw midway between the rich and lean settings.

4. After the idle mixture has been adjusted, hold the governor lever so the throttle lever is in the idle position (against the idle stop screw) and readjust the idle stop screw to bring speed to 1200 ± 50 rpm.
5. With the governor control lever in the governed idle position (no tension on high-speed spring) bend the governed idle spring anchor tang to attain a governed idle speed of 1400 ± 50 rpm.
6. Move the throttle control to the FAST position. Bend the high-speed spring anchor tang to attain a high speed of 2850 ± 50 rpm.

Replacing Spark Plugs

Replace spark plugs after every 800 operating hours. Recommended air gap is 0.030".

Correct spark plug is a Champion RC 12YC.

Note: The spark plug usually lasts a long time; however, the plug should be removed and checked whenever the engine malfunctions.

1. Clean the area around spark plugs so that foreign matter cannot fall into the cylinder when you remove the spark plug.
2. Pull off spark plug wires and remove the plugs from the cylinder head.

3. Check the condition of the side electrode, center electrode, and center electrode insulator to assure there is no damage.

Important A cracked, fouled, dirty or otherwise malfunctioning spark plug must be replaced. Do not sand blast, scrape, or clean electrodes using a wire brush because grit may release from the plug and fall into the cylinder. The result is usually a damaged engine.

4. Set the air gap between the center and side of electrodes at 0.030". Install a gapped spark plug w/gasket seal, and tighten the plug to 200 in-lb. If you don't use a torque wrench, tighten the plug firmly.

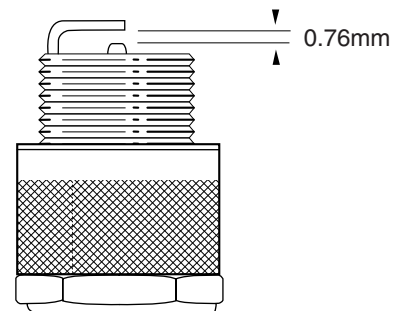

Figure 35

Fuel Filter Replacement

An in-line filter is incorporated into the fuel line between the fuel tank and carburetor. Replace the filter every 800 hours or sooner if fuel flow is restricted. Be sure the arrow on the filter is pointing away from the fuel tank.

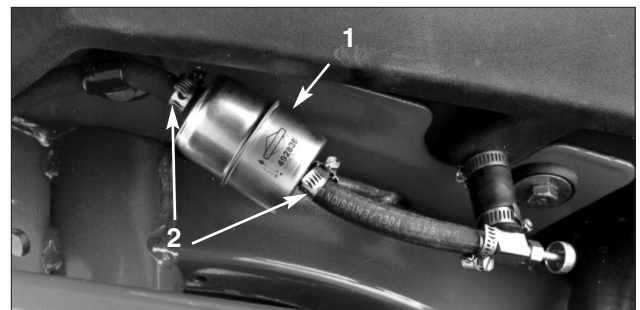

Figure 36

1. Fuel filter
2. Hose clamps

Since gasoline is highly flammable, drain it outdoors and make sure the engine is cool to prevent a fire

hazard. Wipe up any gasoline that may have spilled. Do not drain gasoline near any open flame or where a spark may ignite gasoline fumes. Do not smoke a cigar, cigarette, or a pipe when handling gasoline.

1. Close the fuel shut-off valve, loosen the hose clamp on the carburetor side of the filter and remove the fuel line from the filter.
2. Place a drain pan under the filter, loosen the remaining hose clamp and remove the filter.
3. Install the new filter with the arrow on the filter body pointing away from the fuel tank.

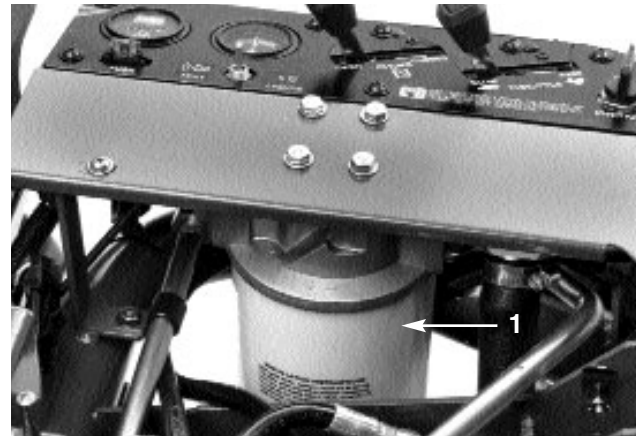

Figure 38

1. Hydraulic Filter

Changing the Hydraulic Oil and Filter

Normally, change the hydraulic oil and filter after every 2,000 operating hours. If the oil becomes contaminated, contact your local TORO distributor because the system must be flushed. Contaminated oil looks milky or black when compared with clean oil.

1. Remove the drain plug from the reservoir and let the hydraulic oil flow into a drain pan. Install and tighten the plug after the hydraulic oil stops draining.



Figure 37

1. Hydraulic Reservoir Drain Plug

2. Clean the area around the filter mounting area. Place a drain pan under the filter and remove the filter.

3. Fill the replacement filter with Mobil DTE 15M hydraulic fluid, lubricate the sealing gasket and hand turn until the gasket contacts the filter head. Then tighten 3/4 turn further. The filter should now be sealed.

4. Fill the large hydraulic tank and small auxiliary tank with approximately 32l of hydraulic oil. Refer to *Check the Hydraulic System*.

5. Start the machine and run it at idle for 3 to 5 minutes to circulate the fluid and remove any air trapped in the system. Stop the machine and recheck the fluid level.

NOTE: If the leak detector alarm sounds, turn the key OFF and wait a few minutes for the oil level to equalize in the tanks. Recheck the fluid level and add oil, if required.

6. Dispose of oil properly.

Checking Hydraulic Hoses and Lines

Check hydraulic lines and hoses daily for leaks, kinked lines, loose mounting supports, wear, loose fittings, weather deterioration and chemical deterioration. Make all necessary repairs before operating.



CAUTION



Keep your body and hands away from pin-hole leaks or nozzles that eject high-pressure hydraulic fluid. Use cardboard or paper to find hydraulic leaks. Hydraulic fluid escaping under pressure can penetrate skin and cause injury. Fluid accidentally injected into the skin must be surgically removed within a few hours by a doctor familiar with this form of injury or gangrene may result.

Brake Adjustment

A brake adjustment rod is located on each side of the Greensmaster 3100 so the brakes can be equally adjusted. Adjust the brakes as follows:

1. Transport the Greensmaster 3100 and depress the brake pedal; both wheels should lock equally.



CAUTION



As a safety precaution, always check brakes in a wide, open-spaced, flat area that is free of other persons and obstructions.

2. If the brakes don't lock equally, disconnect the brake rods by removing the cotter pin and clevis pin.
3. Loosen the jam nut and adjust the clevis accordingly.

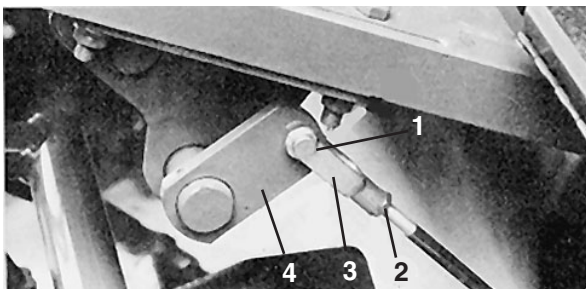

Figure 39

1. Clevis pin & cotter pin
2. Jam nut
3. Clevis
4. Brake shaft

4. Assemble the clevis to the brake shaft.

5. Check the amount of free travel of the brake pedal when adjustment is completed. There should be 1.2–2.5 cm travel before the brake shoes make contact with the brake drums. Re-adjust, if necessary, to achieve this setting.
6. Transport the Greensmaster 3100 and depress the brake pedal; both brakes should lock equally. Readjust them, if necessary.
7. Burnish brakes annually, refer to *Break-in Period*.

Rear Camshaft Adjustment

A camshaft misaligned with the valve bank may cause the following:

- A. No increase in ground speed in No. 2 (transport) traction selection.
- B. The mow pedal will not stay depressed (in detent) without foot pressure.
- C. Slow lift of the cutting units.
- D. Slow or no drive to the cutting units.

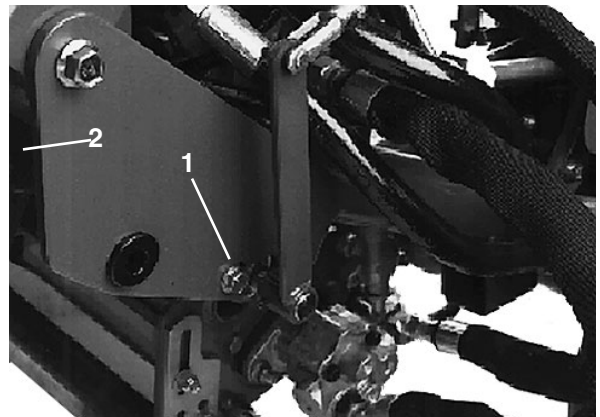

Figure 40

1. Mounting capscrews
2. Cam blocks

1. If one or more malfunctions occur, loosen the rear camshaft mounting capscrews and relocate the cam shaft until the condition is corrected.
2. Retighten the capscrews.

You must readjust the mow/lift switch when the camshaft adjustment is completed and the lift and

mow pedal height.

Adjusting the Lift and Mow Pedal Height

Adjust the lift and mow pedal to equal height to gain proper spool travel in the valve bank as follows:

1. Place 1, 2 and 3 spools in neutral (center of travel) and remove the transfer rod guard from the foot panel.
2. Loosen the jam nut securing the yoke on the front of the long control rod; remove the cotter pin and clevis pin.
3. Move the adjustment lever by hand to level the mow and lift the pedals and adjust the yoke on the control rod until the hole in the yoke lines up with the adjustment lever hole.

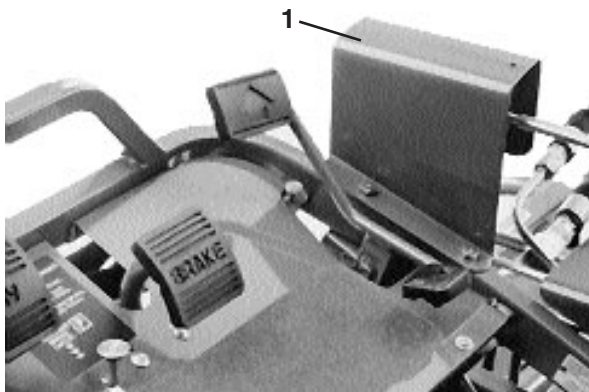

Figure 41

1. Transfer rod guard

4. Install the clevis pin and cotter pin. Tighten the jam nut and install the transfer rod guard.
5. Actuate the mow pedal by hand. Be sure the lift pivot under the pedals clears the stop welded to the frame, thereby allowing full spool travel.

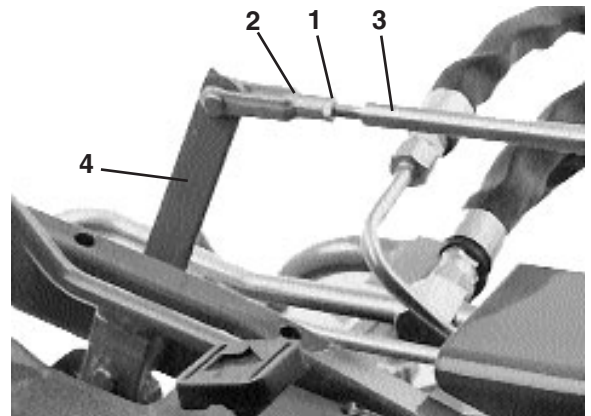

Figure 42

1. Jam nut
2. Yoke
3. Control rod
4. Adjustment lever

Leveling the Lift and Mow Pedals

If the lift and mow pedals are not level when in the neutral position, an adjustment to the lift pivot is required.

1. Loosen the nut on the back side of the lift pivot.
2. Rotate the eccentric screw to raise or lower the lift pivot spring, leveling the lift pivot and pedals.

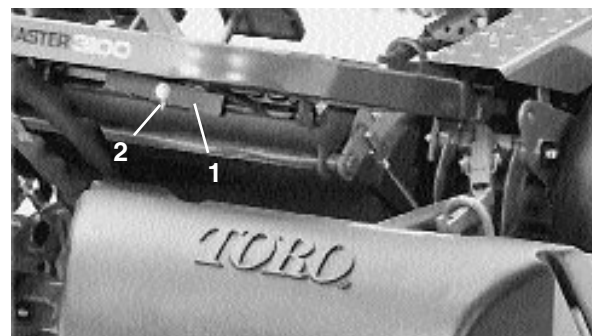

Figure 43

1. Lift Pivot
2. Eccentric Screw

3. While holding the screw, tighten the nut to lock the adjustment.

Adjusting the Traction Pedal

To check forward and reverse operation of the traction pedal, proceed as follows:

Forward

1. Press the traction pedal fully forward until the No. 5 section, valve spool is completely pulled out.
2. The pedal should contact the pedal stop. If the pedal contacts the stop before the spool is completely out, or if the pedal does not make contact with the stop, the stop must be adjusted.

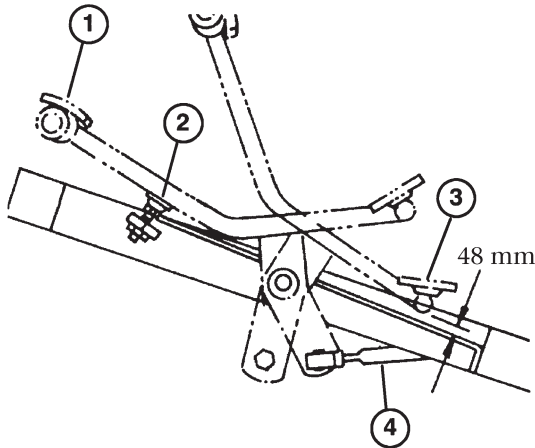

Figure 44

1. Fully forward
2. Pedal stop
3. Reverse
4. Control rod

3. Loosen the hex nut securing the threaded rod to the frame. Turn the flange nut on the rod to raise or lower the stop (rod), while checking the pedal.
4. When completed, tighten the nut.

Reverse

1. Press down on the rear of the traction pedal (reverse) until the No. 5 section spool valve is completely pushed in.
2. Check the distance between the bottom of the pedal and the footrest, as shown in Fig. 48. Distance should be approximately 4.8mm. If the distance is greater or less than 4.8mm, an adjustment to the traction control rod is required.
3. Remove the jam nut and ball joint securing the control rod to the traction shaft pivot.
4. Loosen the jam nuts securing the ball joints to the control rod and adjust the ball joints and

control rod to attain 4.8mm dimension when reinstalled.

Adjusting the Cutting Unit Lift/Drop

1. The machine's cutting unit lift/drop circuit is equipped with a flow control valve. This valve is pre-set at the factory at approximately 3-1/2 turns open, but an adjustment may be required to compensate for differences in hydraulic oil temperatures, mowing speeds, etc. If an adjustment is required, proceed as follows:

Note: Allow hydraulic oil to reach full operating temperature before adjusting the flow control valve.

2. Raise the seat and locate the flow control valve mounted to the main control valve.

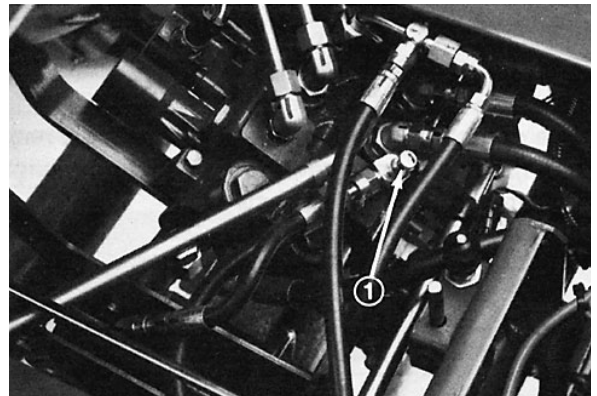

Figure 45

1. Flow control valve

3. Loosen the jam nut retaining the adjusting knob on the flow control. When loosening the jam nut, hold the flow control knob to prevent it from rotating.
4. Rotate the knob 1/4 turn counterclockwise if the center cutting unit is dropping too late or turn it 1/4 turn clockwise if the center cutting unit is dropping too early.
5. After achieving the desired setting, hold the knob to prevent any further rotation and tighten the jam nut.

Adjusting the Lift Cylinders

To regulate the height of the front cutting units when in the raised (transport) position, the front lift cylinders may be adjusted.

1. Lower the cutting units to the floor.
2. Loosen the jam nut on the clevis of the cutting unit lift cylinder you wish to adjust.
3. Disconnect the cylinder clevis from the lift arm.
4. Rotate the clevis until you attain the desired height.
5. Connect the cylinder clevis to the lift arm and tighten the jam nut.

Seat Switch Maintenance

1. Pivot the seat forward and secure it with the support rod to prevent it from falling accidentally and causing injury.
2. Remove the boot from the button end of the seat switch and retain it for installation on the replacement switch. Unplug the switch connectors.

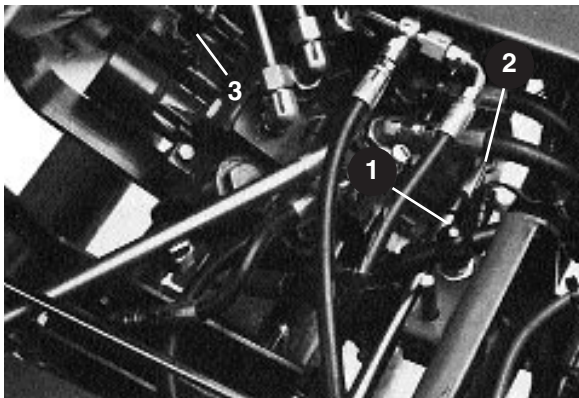

Figure 46

1. Traction switch
2. Seat switch
3. Mow/lift switch

3. Loosen the jam nut and unscrew the switch from the mounting bracket.
4. Screw the new switch through the mounting bracket until the switch button is about 1.6mm

shorter than the top of the seat return spring pin. Install the boot into the mount grooves.

5. Carefully release the seat to its normal down position, but do not sit or apply force on the seat. There should be a slight gap between the switch and the seat plate.
6. Lock the switch in place by tightening the jam nut to 75 in-lb against the mounting bracket.
Important Switch threads will be damaged if the jam nut is over-tightened.
7. Connect a continuity tester or ohm meter to the switch terminals. With the seat in the down position and no one on the seat, the switch circuit should not have continuity. If there is continuity, repeat steps 4–6. If there is no continuity, go to step 8.
8. Sit on the seat. The seat switch should have continuity. If there is no continuity, repeat steps 4–7. If there is continuity go to step 9.
9. Plug the switch connectors together.

Traction Switch Maintenance

1. Pivot the seat forward and secure it with the support rod to prevent it from falling accidentally and causing injury.
2. Unplug the switch connectors from the traction switch installed in the valve bank bonnet on the selector valve section.
3. Loosen the jam nut and unscrew the switch from the mounting bracket.
4. Move the shift selector to neutral.
5. Partially screw the new switch into the bonnet.
6. Connect a continuity tester or ohm meter to the switch terminals and continue to turn the switch in until there is continuity. Then rotate the switch in 1/2 turn (180 degrees).
7. Secure the jam nut to 75 in-lb. against the bonnet.

Important Switch threads will be damaged if

the jam nut is over-tightened.

8. Connect a continuity tester or ohm meter to the switch terminals and move shift selector to the #1 and #2 positions. There should not be continuity when the shift selector is in either of these positions. If there is continuity, repeat steps 5 and 6.
9. Move the shift selector lever to neutral and connect a continuity tester or ohm meter to the switch terminals. The switch should show continuity. This means the switch is operating correctly.
10. Plug the switch connectors together.

Mow/Lift Switch Maintenance

Important Spool travel for 1, 2 and 3 spools must be correct before the mow/lift switch can be adjusted. Refer to *Rear Camshaft Adjustment*.

1. Pivot the seat forward and secure it with the support rod to prevent it from falling accidentally and causing injury.
2. Unplug the switch connectors from the end of the mow/lift switch installed in the valve bank bonnet.
3. Loosen the jam nut and unscrew the switch from the valve bank bonnet.
4. While holding the lift pedal in a fully depressed position (valve bank spools fully IN), partially screw the new switch into the bonnet.
5. Connect a continuity tester or ohm meter across the switch terminals and turn the switch in until continuity occurs. Then rotate the switch in 1/2 turn (180 degrees) and secure the jam nut to 75 in-lb. against the bonnet.

Important Switch threads will be damaged if the jam nut is over-tightened.

6. Connect a continuity tester or ohm meter to the switch terminals and depress the mow pedal. There should not be continuity. If there is continuity, repeat step 4. Go to step 7 if there is no continuity.

7. Depress the lift pedal and release it (neutral position). The switch circuit should have continuity.
8. Plug the switch connectors together.

Adjusting the Traction Return Linkage

If the shift selector lever does not return to the neutral or #1 position from the #2 position when the mow pedal is engaged, an adjustment to the traction return linkage is required.

1. Loosen the front jam nut securing the cable assembly to the mow/lift control rod bracket.
2. Move the shift lever to the #1 position.
3. While holding the mow/lift control rod in the rear position, tighten the rear locknut to remove almost all slack from the cable assembly. Do not over-tension the cable.
4. Tighten the front jam nut to lock adjustment.
5. Check operation and re-adjust as required.

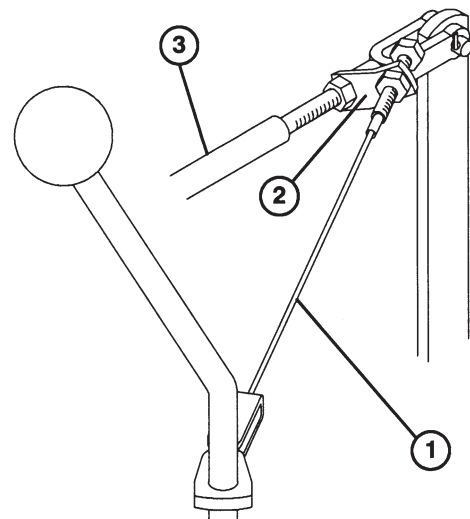

Figure 47

1. Cable assembly
2. Mow/lift control rod bracket
3. Mow/lift control rod

Battery Care

1. Battery electrolyte level must be properly maintained and the top of the battery kept clean.

If the Greensmaster 3100 is stored in a location where temperatures are extremely high, the battery will run down more rapidly than if the machine is stored in a location where temperatures are cool.

Since the gasses from the battery and the gasoline fumes are explosive, keep open flame and electrical sparks away from the area; do not smoke.

2. Check the electrolyte level every 50 operating hours or, if the machine is in storage, every 30 days.
3. Maintain cell level with distilled or demineralized water. Do not fill cells above the bottom of the split ring inside each cell.
4. Keep the battery top clean by washing it periodically with a brush dipped in ammonia or bicarbonate of soda solution. Flush the top surface with water after cleaning. Do not remove the fill caps while cleaning.
5. Battery cables must be tight on the battery terminals to provide good electrical contact.
6. If corrosion occurs at the terminals, disconnect the cables—negative (–) cable first—and scrape the clamps and terminals separately. Reconnect the cables—positive cable first—and coat the terminals with petroleum jelly.

Troubleshooting

CONDITION	CAUSE	CORRECTION
ENGINE:		
1. Loss of power	<ul style="list-style-type: none"> • Out of fuel • Clogged fuel line—debris in the fuel tank • Clogged fuel filter • Low crankcase oil level • Wrong oil in the crankcase • Carburetor fuel solenoid • Throttle cable set incorrectly • Choke closed • Plugged air cleaner element • Carburetor malfunction • Ignition malfunction • Cooling fins plugged with debris.. Engine overheating. • Internal engine malfunction • Engine-pump coupling loose • Hydraulic system malfunction 	<ul style="list-style-type: none"> • Re-fill the fuel tank • Clean the fuel tank. Use clean gasoline. • Replace the filter • Add oil. Check the oil level more often. • Replace with correct oil • Check solenoid and wiring • Repair as necessary • Readjust • Replace the element. Service more often. • Repair as necessary. • Repair as necessary. • Clean fins. Repair the engine as necessary. • Repair as necessary. • Repair or replace. • Refer to <i>Hydraulic Trouble Shooting</i>, (See below).
2. Engine won't start	<ul style="list-style-type: none"> • Faulty ignition system • No fuel • Defective starter system • Carburetor fuel solenoid 	<ul style="list-style-type: none"> • Repair as necessary • Check the fuel level. Add gasoline to the tank. • Check connections, solenoid, starter motor, ignition switch. • Check solenoid and wiring.
HYDRAULIC:		
1. No ground speed increase in #2 selection.	<ul style="list-style-type: none"> • Maladjusted control lever. • Maladjusted rear camshaft. • Mow-lift linkage binding or broken lift pivot spring. • Wrong detent parts in #4 spool. • #2 or #3 spool relief valves stuck open. (Reel drive RPM will also be low on #1 or #3 cuffing unit). 	<ul style="list-style-type: none"> • Adjust. Refer to <i>Traction Switch Adjustment</i>. • Adjust by moving right-hand end of the rear camshaft forward or left-hand end rearward. • Lubricate or repair the machine. • Remove valve bank & repair #4 spool assembly. • Remove, and repair or replace the relief cartridge.
2. No #1 or Reverse Traction speed. Normal #2 speed.	<ul style="list-style-type: none"> • Defective or missing disc seal between the #3 or #4 valve sections. • Poppet inside #4 spool stuck open. Off seat. • Open traction relief cartridge in the #4 spool section. 	<ul style="list-style-type: none"> • Remove the valve bank. Replace the disc seal. • Remove the valve bank. Repair the #4 spool section. • Remove the relief cartridge. Repair or replace it.

CONDITION	CAUSE	CORRECTION
3. No #1 or Reverse Traction speed. Normal #2 speed.	<ul style="list-style-type: none"> • Traction motor lacks efficiency. Fluid leaking past internal gears. • Hydraulic pump lacks efficiency. Fluid leaking past internal gears. 	<ul style="list-style-type: none"> • Test to identify faulty motor. Repair or replace the motor. • Test to verify diagnosis. Repair or replace the pump.
4. Slow or no traction in all selections.	<ul style="list-style-type: none"> • Brakes dragging • Faulty O-ring seals around the traction relief cartridge or the inlet sleeve in #4 spool valve. Fluid leaking by the tank. • Worn or weak traction motor(s). • Pump excessively worn. • Traction relief in #4 spool valve open 	<ul style="list-style-type: none"> • Determine cause & repair • Remove the relief and inlet sleeve. Replace the O-rings. • Test to verify. Repair or replace motor(s). • Test to verify. Repair or replace. • Remove, repair or replace.
5. Slow or no traction in all selections. (Reels affected)	<ul style="list-style-type: none"> • Low oil level in the reservoir • Loose shift lever bracket • Maladjusted rear camshaft • Engine lacks power 	<ul style="list-style-type: none"> • Add oil to the proper level • Readjust & tighten the shift lever • Readjust • Repair as necessary
6. Binding shift lever	<ul style="list-style-type: none"> • Lack of lubrication in #4 spool detent assembly. 	<ul style="list-style-type: none"> • Remove the valve bank. Dissassemble the detent assembly & repair.
7. All 3 cuffing units raise and lower too slowly.	<ul style="list-style-type: none"> • Binding lift cylinders & linkages. (lack of lubrication). 	<ul style="list-style-type: none"> • Lubricate more frequently.
8. Center cutting (#1) unit dropping too late or too early.	<ul style="list-style-type: none"> • Maladjusted flow control valve 	<ul style="list-style-type: none"> • Readjust
9. Front cutting units too high or too low when raised (transport) position.	<ul style="list-style-type: none"> • Maladjusted front lift cylinders 	<ul style="list-style-type: none"> • Readjust
10. Cutting units lift too slowly.	<ul style="list-style-type: none"> • Rear camshaft maladjusted • #2 spool travel restricted by the mow-lift switch. • The lift check poppet in #1 spool section is stuck partially closed. 	<ul style="list-style-type: none"> • Readjust • Readjust the switch • Remove the lift check. Repair or replace.

CONDITION	CAUSE	CORRECTION
11. Cutting units drop during transport (between greens)	<ul style="list-style-type: none"> • Internal lift cylinder leak • Lift check plug seals in the #1 spool body are defective • The detent stud in the #1 spool is loose • #1 spool is loose in valve body Fluid bypassing. 	<ul style="list-style-type: none"> • Raise units & block them up. Remove lines from brazed tube & remove blocks. Line which leaks fluid is attached to bad cylinder. Repair cylinder. • Remove lift check plugs. Replace O-ring assemblies. • Remove adjustment cap from the #1 spool bonnet. Retighten the stud with a screwdriver. • Replace spool valve assembly
12 Cutting units drop while the machine is stored. (Overnight)	<ul style="list-style-type: none"> • Normal condition 	<ul style="list-style-type: none"> • No repair necessary
13. One or more cutting units are slow or there is no reel drive action.	<ul style="list-style-type: none"> • The bedknife-to-reel adjustment is too tight • Tight reel bearings • Rear camshaft is maladjusted • Poppet in relief cartridge off seat. • Improper suction line(s) installed. Line collapsed. • Blockage in line fitting. • Excessively worn motor. • Slow reel rpm—No. 1 C.U. • Excessively worn pump • Spool loose in valve body. Fluid leak past spool. • Steel pressure line damaged. Flow restricted. (Front cutting units only). • Low fluid level. (Will affect total machine performance). 	<ul style="list-style-type: none"> • Readjust per instructions in the operator's manual for cutting unit. • Repair as necessary • Readjust • Remove and repair or replace the relief cartridge • Remove. Use genuine TORO parts only. • Repair as necessary • Test to verify. Repair or replace the motor. • Check the lift cylinders for internal leakage. Repair or replace. • Test to verify. Repair or replace. • Replace the spool valve assembly. • Replace the line. • Add fluid.
14. Center cutting unit (#1) reel operates in the raised position.	<ul style="list-style-type: none"> • Rear camshaft maladjusted. The #3 spool is too far out of body. • Restriction in brazed tube assembly on the #3 spool section. • Restriction in the valve return port between the #3 spool section and right-hand cover. 	<ul style="list-style-type: none"> • Readjust the camshaft • Remove restriction • Disassemble the cover & remove the restriction.
15 Reel drive pressure lines pulsates during operation.	<ul style="list-style-type: none"> • Normal condition. Will vary from line to line. 	<ul style="list-style-type: none"> • No repair necessary.

CONDITION	CAUSE	CORRECTION
16. Mow pedal won't stay down unless it is held down with foot. (#1 spool not in "detent").	<ul style="list-style-type: none"> • The rear camshaft is maladjusted. • Defective #1 spool detent 	<ul style="list-style-type: none"> • Readjust the camshaft • Remove and repair
17. Leak detector alarm sounds.	<ul style="list-style-type: none"> • Oil leak in the system • Low fluid level • Oil contracting as it cools, due to prolonged idling after heavy use. • Solenoid valve fails to open 	<ul style="list-style-type: none"> • Repair as necessary • Add fluid • Turn the engine off for approximately one minute, while the main hydraulic tank is refilled from auxiliary tank. • Repair as necessary
18. Leak detector alarm fails to sound.	<ul style="list-style-type: none"> • The leak detector float switch is not operating properly • The time delay operates incorrectly • The alarm doesn't operate • Electrical malfunction • The solenoid valve fails to close 	<ul style="list-style-type: none"> • Check operation of the leak detector float switch and wiring. • Replace • Replace • Test to verify. Repair as necessary. • Repair as necessary

ELECTRICAL

1. The engine starts (but it shouldn't) when the shift selector is in gear	The traction switch is adjusted incorrectly or is defective.	Refer to <i>Traction Switch Maintenance</i> .
2. The engine starts (but it shouldn't) when the mow pedal is depressed (reels engaged).	The mow/lift switch is adjusted incorrectly or is defective.	Refer to <i>Mow/Lift Switch Maintenance</i> .
3. The engine starts (but it shouldn't) when an operator is not on seat.	The seat switch is adjusted incorrectly or is defective.	Refer to <i>Seat Switch Maintenance</i> .

CONDITION	CAUSE	CORRECTION
<p>4. The engine fails to crank, regardless of shift selector or mow pedal position.</p>	<ul style="list-style-type: none"> • The mow/lift switch, traction switch and/or seat switch adjusted incorrectly or are defective. • Battery terminals are corroded • The mow/lift or traction switch wires are loose • The battery is dead • The solenoid is defective • The ignition switch is defective • The starter is defective • The engine is seized • The key switch, voltmeter, or solenoid wires are loose • The operator must be on seat. 	<ul style="list-style-type: none"> • Refer to Traction Switch Maintenance • Refer to Mow/Lift Switch Maintenance • Refer to Seat Switch Maintenance. • Clean terminals. • Check wires and connect them properly • Charge or replace the battery • Replace the solenoid • Replace the ignition switch • Replace or repair the starter • Repair the engine • Connect wires • Sit on the seat
<p>5. The engine cranks but does not start when the shift selector and mow pedal are in neutral.</p>	<ul style="list-style-type: none"> • The cause of this problem is unrelated to interlock wiring system. • The rear camshaft is maladjusted. • The engine or rectifier plug is loose • The “ I “ terminal wire of the key switch is loose • Engine trouble or out of gas. • Parking brake kill relay defective 	<ul style="list-style-type: none"> • All interlock switches are OK; therefore, go to next cause. • Refer to <i>Rear Camshaft Adjustment</i> • Connect wire • Connect wire • Determine problem and correct • Replace relay
<p>6. The engine does not stop when mow pedal is depressed (reels engaged) as you get off the seat.</p>	<ul style="list-style-type: none"> • The mow/lift or seat switch adjusted incorrectly or are defective. • The seat return pin spring broken, missing or jammed down. • The seat pivot fails to rotate freely. 	<ul style="list-style-type: none"> • Refer to <i>Mow/Lift Switch Maintenance</i>. • Refer to <i>Seat Switch Maintenance</i>. • Replace, loosen and lubricate parts so pin operates freely. • Loosen and lubricate the seat pivot pin to assure free movement.
<p>7. The engine does not stop when the shift selector is in gear as you get off the seat.</p>	<ul style="list-style-type: none"> • The traction or seat switch is adjusted incorrectly or they are defective. • The seat return pin spring broken, missing or jammed down. • The seat pivot fails to rotate freely. 	<ul style="list-style-type: none"> • Refer to <i>Traction Switch Maintenance</i>. • Refer to <i>Seat Switch Maintenance</i>. • Replace, loosen and lubricate parts so the pin operates freely. • Loosen and lubricate the seat pivot pin to assure free movement.

CONDITION	CAUSE	CORRECTION
<p>8. The engine does not continue to run when sitting on seat and shift selector is placed in gear or mow pedal is depressed.</p>	<ul style="list-style-type: none"> • The seat switch adjusted incorrectly or is defective. • The seat return pin spring jammed in the up position. • The parking brake switch wires are loose. • The parking brake switch wires are defective 	<ul style="list-style-type: none"> • Refer to <i>Seat Switch Maintenance</i>. • Loosen and lubricate jammed parts so pin operates freely. Replace spring if defective. • Connect wires • Replace the switch
<p>9. The engine stops regardless of shift selector or mow pedal position (even if both are in "Neutral") as you get off the seat.</p>	<ul style="list-style-type: none"> • The mow/lift switch and/or traction switch is adjusted incorrectly or are defective. • The mow/lift and/or traction switch wires are loose. • The traction switch extension plug wires are loose. • The "B" terminal wire of the key switch is loose. 	<ul style="list-style-type: none"> • Refer to <i>Switch Maintenance</i>. • Connect wires. • Connect wires. • Connect wire.
<p>10. The engine seems to "cut-out" too much during transport. Note: Some "cut-out" is normal.</p>	<ul style="list-style-type: none"> • Seat is lifting the off seat switch button too easily 	<ul style="list-style-type: none"> • Adjust the seat switch: refer to <i>Seat Switch Maintenance</i>. • Instruct the operator to sit back in the seat during transport.
<p>11. The engine does not stop when the ignition key is rotated to the OFF position.</p>	<ul style="list-style-type: none"> • C ignition switch • Ignition switch is defective • Wires in the connector have shorted • The engine timing or carburetor adjustment is incorrect. 	<ul style="list-style-type: none"> • Push the connector onto the ignition switch terminals. • Replace the ignition switch • Repair affected wires • Adjust carburetor or engine timing
<p>12. The battery does not charge.</p>	<ul style="list-style-type: none"> • Defective or missing fuse • Loose wire(s) in the electrical system • Defective regulator or engine charging circuit 	<ul style="list-style-type: none"> • Install a new fuse • Check all connections and make all necessary repairs • Install a new regulator or repair the engine charging circuit.
<p>13. The engine does not stop when sitting on seat and shift selector is in gear with parking brake on.</p>	<ul style="list-style-type: none"> • The connector is off the parking brake kill relay • The parking brake switch is defective • The diode is defective 	<ul style="list-style-type: none"> • Push the connector onto the parking brake kill relay • Replace the parking brake switch • Replace the diode

Storage

If you wish to store the Greensmaster 3100 for a long period of time, take the following steps before storage:

1. Remove accumulations of dirt and old grass clippings. Sharpen the reels and bedknives, if necessary; refer to the cutting unit operator's manual. Use a rust preventive on bedknives and reel blades. Grease and oil all lubrication points; refer to *Lubrication*.
2. Block up wheels to remove the tire weights.
3. Drain and replace the hydraulic fluid and filter, inspect hydraulic lines and fittings. Replace, if necessary; refer to *Changing Hydraulic Oil and Filter* and *Checking Hydraulic Lines and Hoses*.
4. All fuel should be removed from the fuel tank; run the engine until it stops from lack of fuel. The small amount of fuel that remains in the bottom of the tank should be removed by absorbing it with a clean dry cloth. Replace the fuel filter; refer to *Fuel Filter Replacement*.
5. While the engine is still warm, drain oil from the crankcase. Refill with fresh oil; refer to *Changing Engine Oil and Filter*.
6. Remove the spark plugs, pour 3cl of SAE 30 oil into the cylinders and crank slowly to distribute the oil. Replace the spark plugs; refer to *Replacing Spark Plugs*.
7. Clean dirt and chaff from the cylinder, cylinder head fins and blower housing.
8. Remove the battery and charge it fully. Either store it on the shelf or on the machine. Leave the cables disconnected if stored on the machine. Store the battery in a cool atmosphere to avoid quick deterioration of the charge in the battery.
9. If possible, store in a warm, dry location.

Identification and Ordering

Model and Serial Numbers

The Greensmaster 3100 has two identification numbers: a model number and a serial number. The two numbers are stamped on a plate, which is riveted on the right inside of the footrest support. In any correspondence concerning the Greensmaster 3100, supply the model and serial numbers to be sure that you obtain correct information and replacement parts.

To order replacement parts from an authorized TORO distributor, supply the following information:

1. Model and serial numbers of the machine.
2. Part number, description and quantity of parts desired.

Note: Do not order by reference number if a parts catalog is being used; use the part number.