

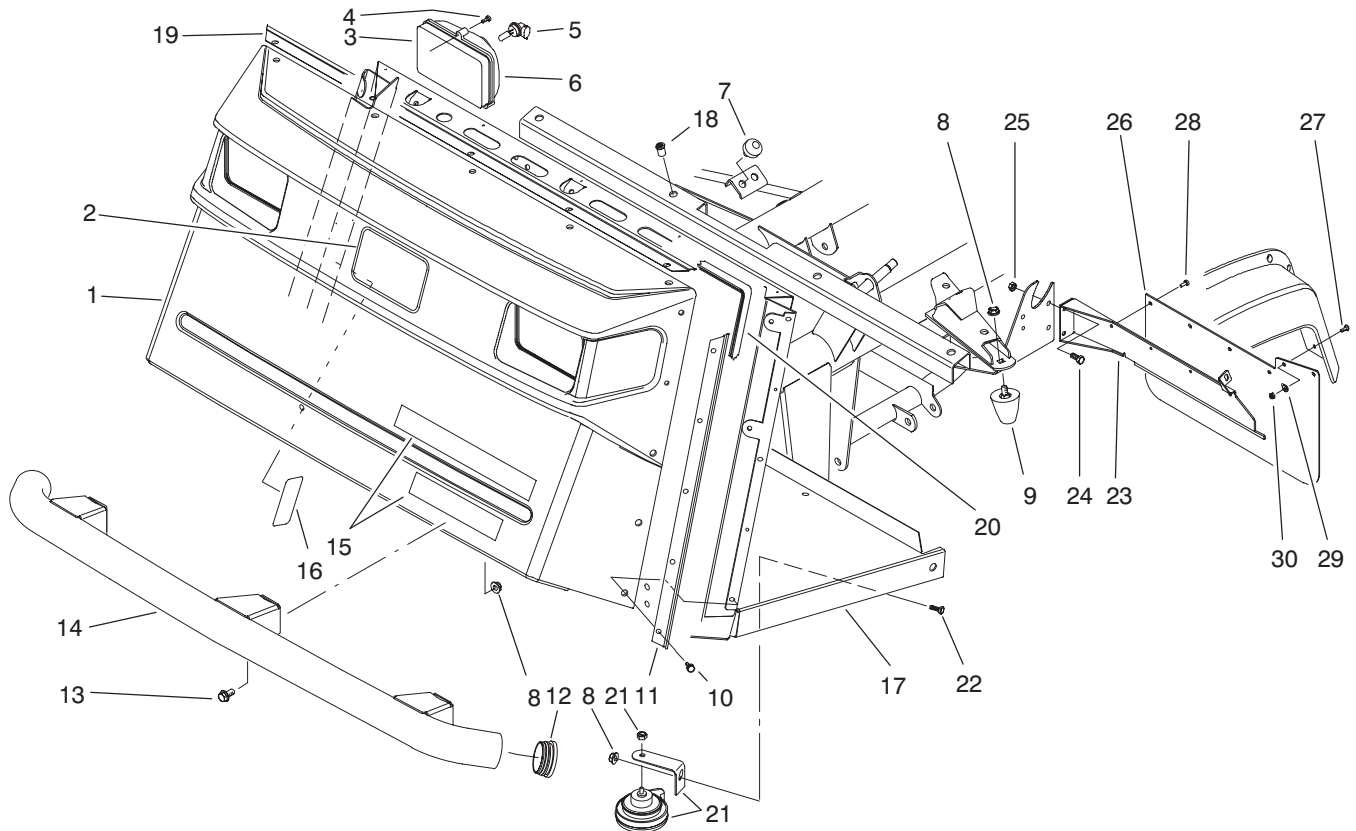

MODEL NO. 07210-20000230 & Up

PARTS
CATALOG

WORKMAN® 3100



T-1581-1

FRONT BUMPER & HOOD ASSEMBLY

Ref. No.	Part No.	Description	No. Used	Ref. No.	Part No.	Description	No. Used
1	87-0710	Hood	1	17	94-5240	Operators Platform Assy. (Incl. Ref. #18)	1
2	62-5550	Decal - TORO	1	18	32148-7	Nut - Clinch	8
3	87-2120	Headlight Assembly (Incl. Ref. #5-6)	2	19	87-8130-03	Bracket - Trim Top	1
4	32104-88	Screw	6	20	87-8160	Trim	1
5	87-6320	Bulb - Headlight	2	21	116749	Horn Assembly	1
6	87-6330	Lens - Headlight	2	22	323-4	Screw - Cap Hex. Hd.	1
7	87-2440	Bumper	2	23	94-3838-03	Bracket - Mudflap LH	1
8	3290-357	Nut - Flange Lock	9	*	94-3839-03	Bracket - Mudflap RH	1
9	26-0071	Bumper	2	24	321-4	Screw - Cap Hex. Hd.	4
10	87-6620	Screw	15	25	32128-33	Nut - Lock	4
11	87-8120-03	Bracket - Trim Side	2	26	94-3841	Mudflap	2
12	2410-42	Cap - Front Bumper	2	27	3250-13	Screw - Pan Hd.	4
13	3234-1	Screw - Hex. Flange Hd.	6	28	146489	Rivet - Pop	8
14	87-4070-03	Bumper - Front	1	29	3256-61	Washer - Flat	4
15	87-6030	Decal - Workman 3100	1	30	3296-2	Nut - Lock	4
16	87-9510	Decal - Load Rating	1				

*Not Illustrated

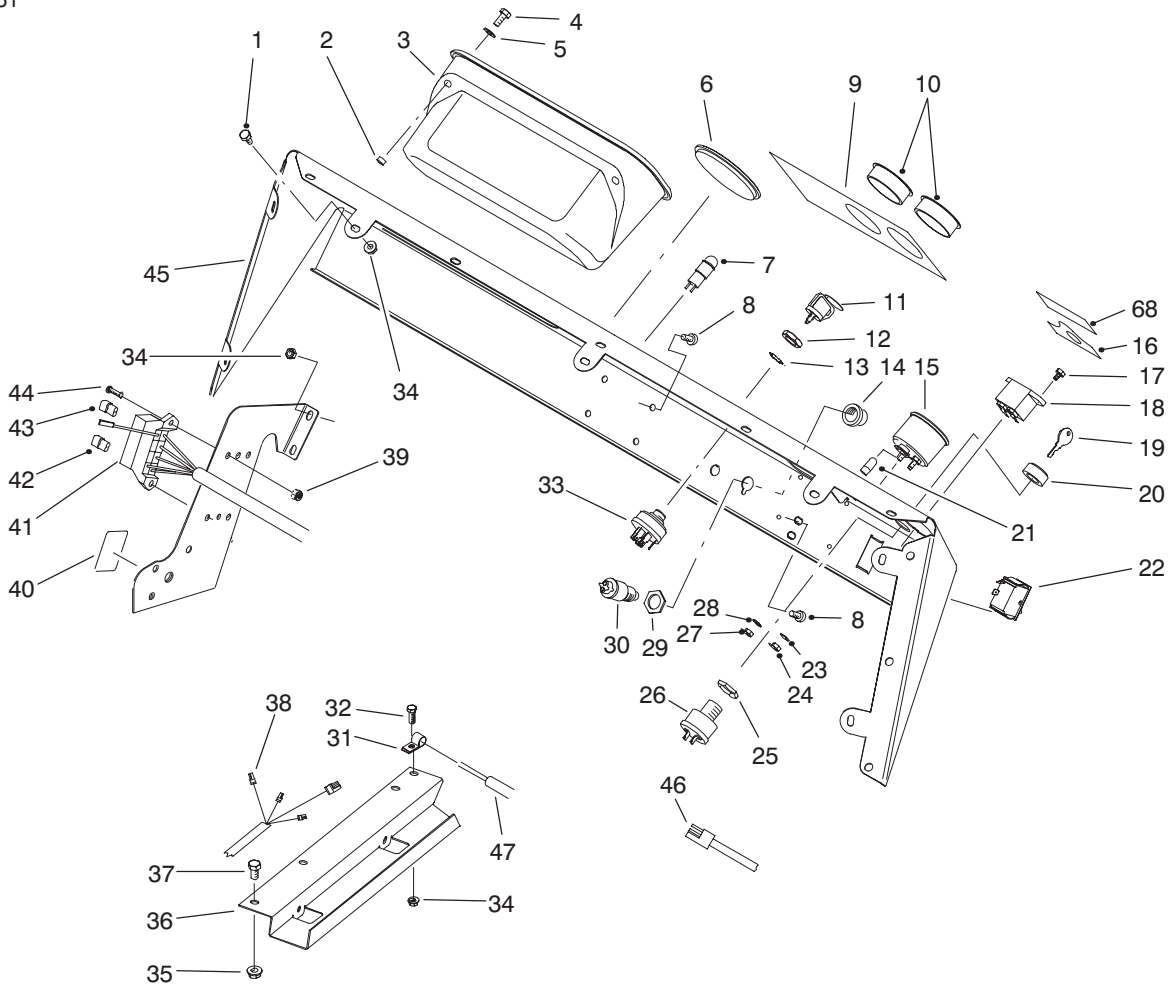

T-1729-1

CONTROL PANEL ASSEMBLY

Ref. No.	Part No.	Description	No. Used
1	321-2	Screw - Cap Hex. Hd.	7
2	32148-6	Insert - Threaded	2
3	87-3780	Box - Glove	1
4	321-3	Screw - Cap Hex. Hd.	2
5	3256-22	Washer - Flat	2
6	2410-35	Plug - Hole	1
7	87-8580	Light - Indicator (Red)	1
8	3274-31	Screw - Hex. Socket Hd.	4
9	87-7910	Decal - Dash	1
10	87-8360	Plug - Hole	2
11	63-8360	Key - Ignition	1
12	218-446	Nut - Hex.	1
13	218-447	Washer - Lock	1
14		Button - Horn	1
15	87-5580	Fuel Gauge Assembly (Incl. Ref. #23, 24, 27 & 28)	1
16	87-5910	Decal - Supervisor	1
17	32144-18	Screw - Cap Hex. Hd.	2
18	75-6820	Hourmeter	1
19	87-0740	Key - Supervisor Switch	1
20	87-1720	Nut - Supervisor Switch	1
21	218-600	Bulb	1
22	87-3790	Switch - Light	1
23	3253-15	Washer - Lock	2
24	3217-25	Nut - Hex.	2
25		Nut - Hex.	1

Ref. No.	Part No.	Description	No. Used
26	94-5245	Supervisor Switch Assy. (Incl. Ref. #19, 20 & 25)	1
27	3217-29	Nut - Hex.	3
28	3253-19	Washer - Lock	3
29		Nut - Hex.	1
30	18-2830	Horn Switch Assembly (Incl. Ref. #14 & 29)	1
31	2412-89	Clamp - R	1
32	321-4	Screw - Cap Hex. Hd.	1
33	27-2360	Ignition Switch Assembly (Incl. Ref. #12 & 13)	1
34	32128-33	Nut - Flange	12
35	32128-20	Nut - Flange	3
36	93-7094-03	Cover - Wire Harness	1
37	322-2	Screw - Cap Hex. Hd.	3
38	99-1115	Harness - Wire Rear	1
39	3296-2	Nut - Lock	2
40	87-6670	Decal - Fuse Block	1
41	87-8200	Harness - Wire Front	1
42	218-574	Fuse 7.5 Amp.	2
43	218-581	Fuse 15 Amp.	1
44	3250-13	Screw	2
45	87-8560	Control Panel Assembly (Incl. Ref. #9,16 & 48)	1
46	87-4230	Harness - Wire Front LH	1
47	94-3837	Cable - Clutch	1
48	94-5272	Decal - Warning	1

ELECTRICAL SCHEMATIC

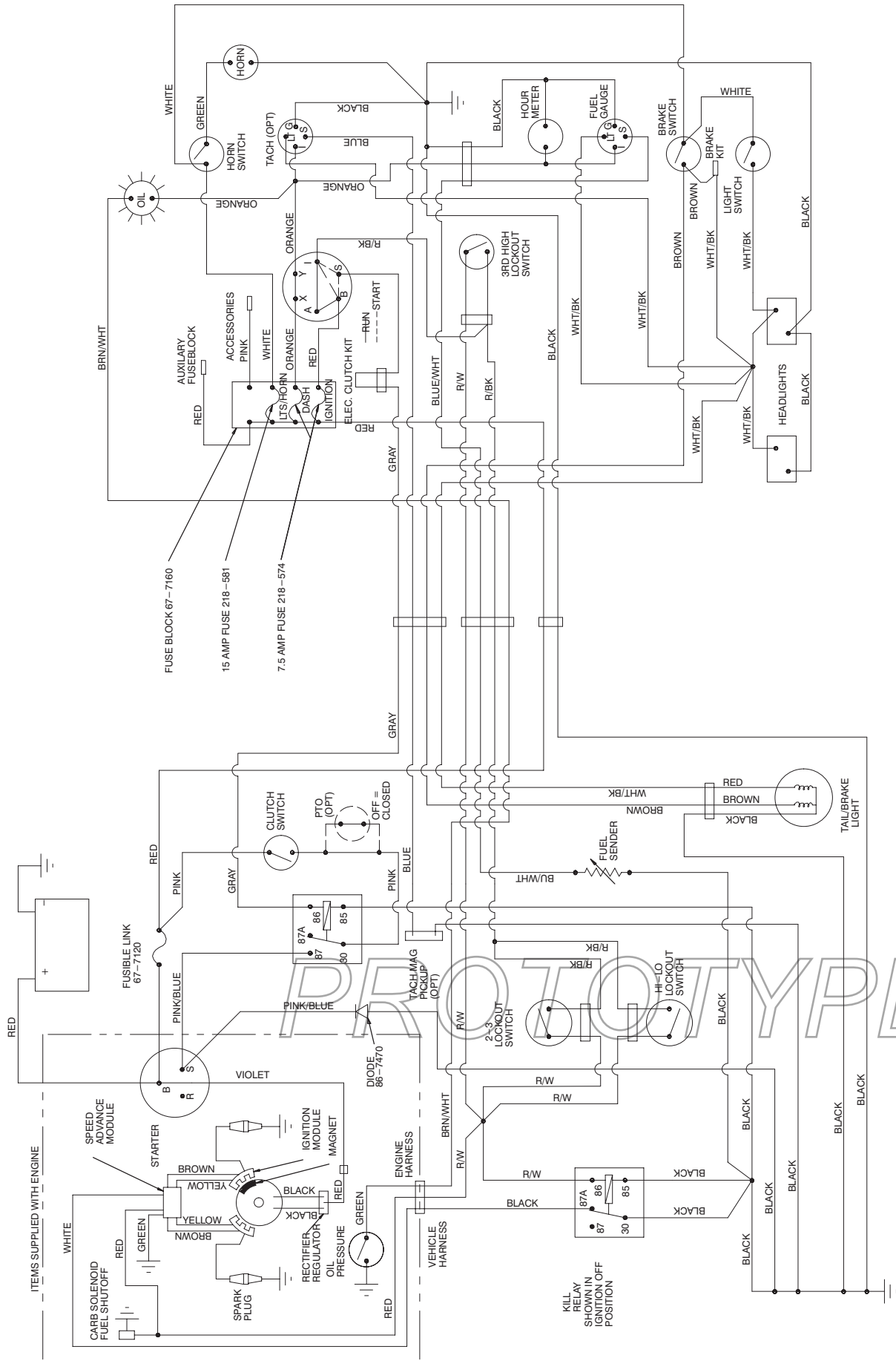

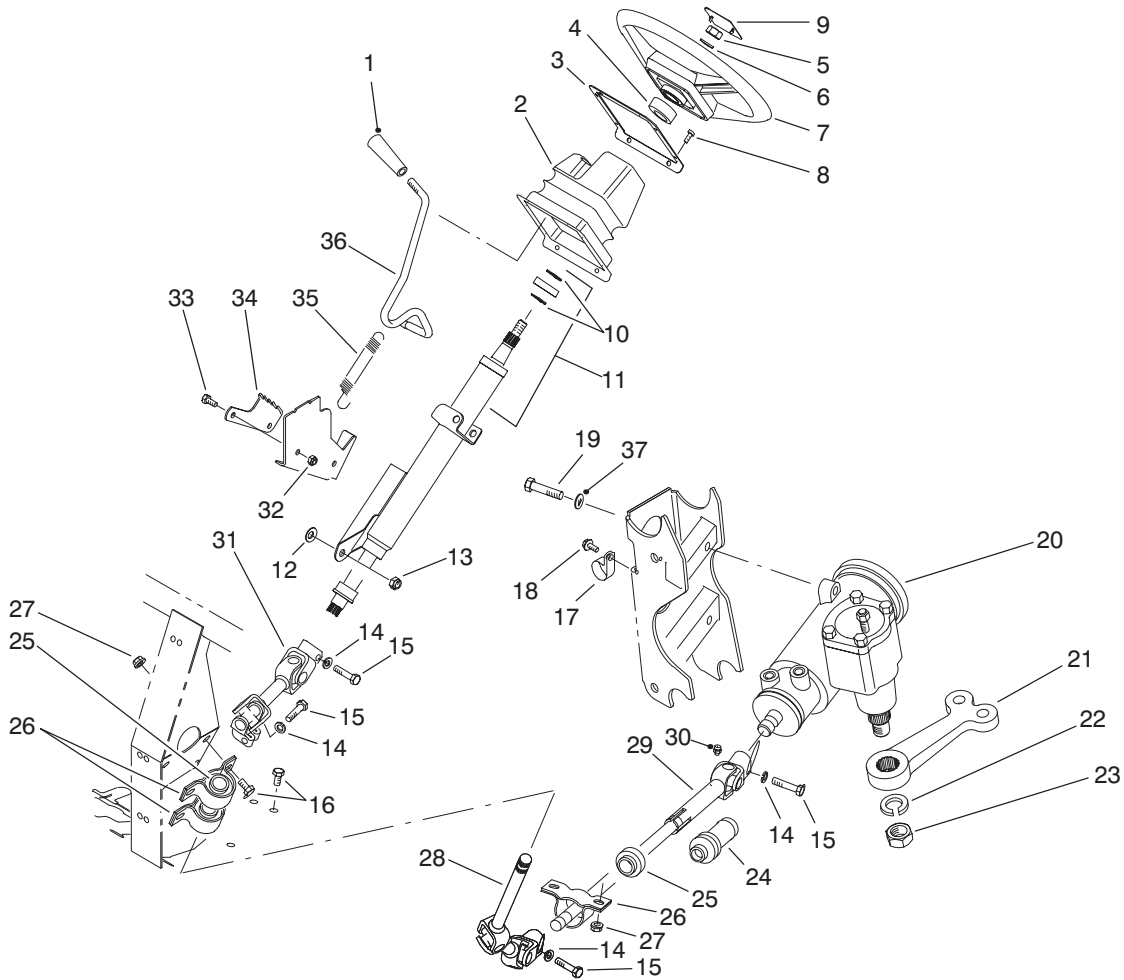

T-1584-1

STEERING LINKAGE ASSEMBLY

Ref. No.	Part No.	Description	No. Used	Ref. No.	Part No.	Description	No. Used
1	233-39	Knob	1	21	87-0370-03	Arm - Pitman	1
2	87-3460	Boot - Tilt Steering	1	22	39-7420	Washer - Lock	1
3	87-4720-03	Plate - Steering Boot	1	23	39-7440	Nut - Lock	1
4	21-9260	Spacer	1	24	92-4157	Boot - Steering Shaft	1
5	3277-1	Nut - Hex.	1	25	87-2280	Bearing	3
6	48-8070	Washer - Flat	1	26	87-3250	Mount - Bearing	3
7	87-3820	Wheel - Steering	1	27	32128-20	Nut - Flange	6
8	32144-116	Screw - Pan Head	8	28	92-4155	Upper Slip Joint Assembly	1
9	87-3750	Cover - Steering Wheel	1	29	92-4156	Lower Slip Joint Assembly (Incl. Ref. #24 & 30)	1
10	43-6550	Ring - Retaining	2	30	302-5	Fitting - Grease	1
11	92-4153	Steering Column Assembly (Incl. Ref. #10)	1	31	92-4154	Universal Joint Assembly	1
12	3290-455	Washer	1	32	3296-42	Nut - Lock	2
13	3296-59	Nut - Lock	1	33	321-3	Screw - Cap Hex. Hd.	2
14	3253-4	Washer - Lock	4	34	87-3610	Bracket - Detent	1
15	48-7740	Screw - Cap Hex. Hd.	4	35	65-5360	Spring - Extension	1
16	322-2	Screw - Cap Hex. Hd.	6	36	87-3130	Lever - Tilt Steering	1
17	2412-105	Clamp - R	2	37	87-7480	Washer - Flat	3
18	32144-10	Screw - Self Tapping	2	*	87-3100	Lower Shaft Assembly (Incl. Ref. #24 & 28-30)	1
19	93-7145	Screw - Cap Hex. Hd.	3	*	87-3120	Steering Column & Shaft (Incl. Ref. #10, 11 & 31)	1
20	87-1500-03	Steering Gear Assembly (Incl. Ref. #22 & 23)	1				

*Not Illustrated

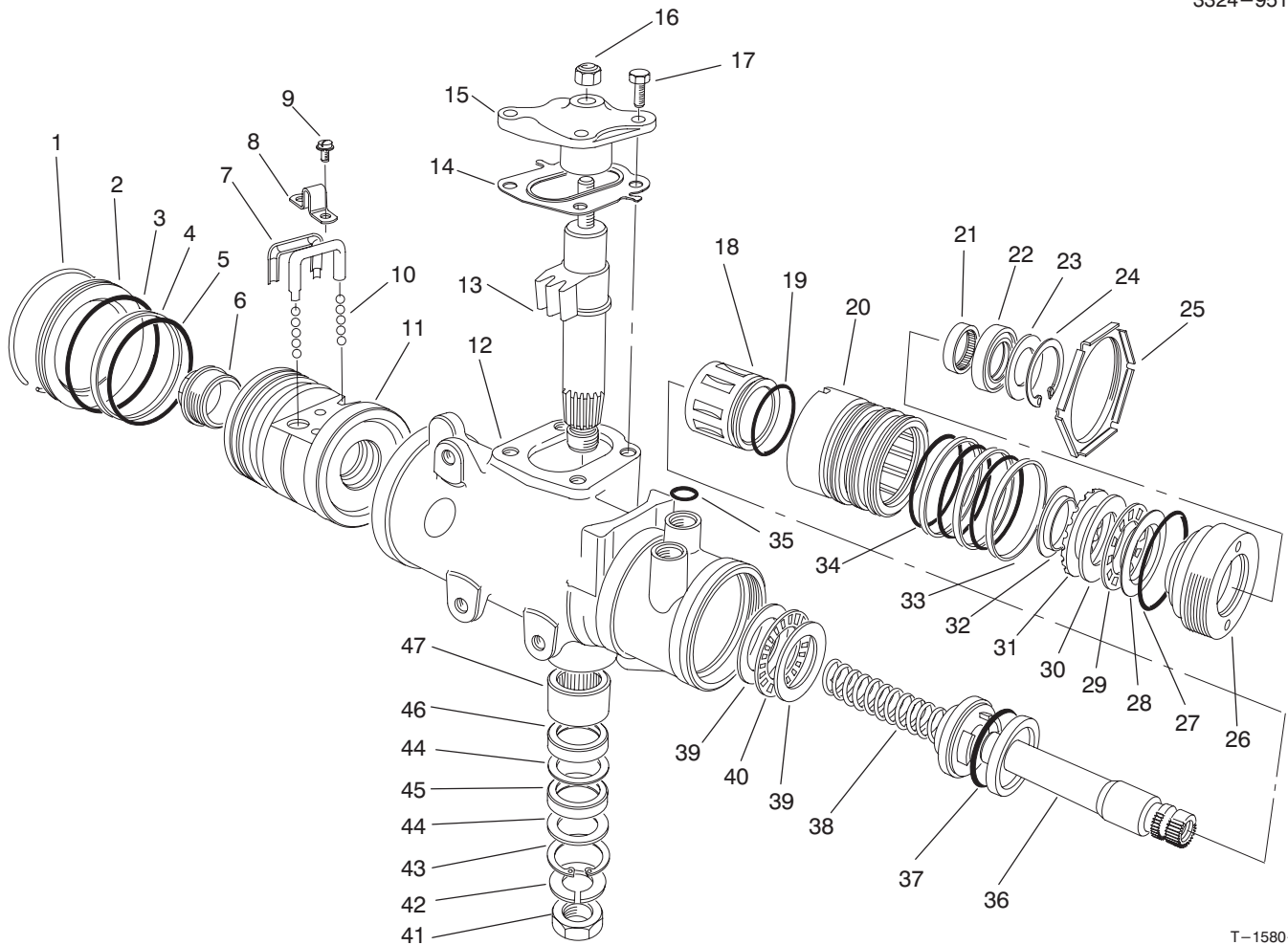

T-1580-1

STEERING GEAR ASSEMBLY NO. 87-1500

Ref. No.	Part No.	Description	No. Used	Ref. No.	Part No.	Description	No. Used
1		Ring - Retaining	1	24		Ring - Retaining	1
2	92-4165	Plug - Housing End	1	25	92-4159	Nut - Adjuster Plug Lock	1
3		Seal - Housing End Plug	1	26		Plug - Adjuster	1
4		Ring - Rack Piston	1	27	28-8200	O-Ring	1
5		O-Ring, Rack Piston	1	28		Race - Upper Bearing	1
6	18-4340	Plug - Rack Piston End	1	29		Bearing - Roller, Thrust	1
7	92-4168	Return - Guide Ball	2	30		Race - Thrust Bearing	1
8	18-4270	Clamp - Ball Return Guide	1	31		Spacer - Thrust Bearing	1
9	18-4260	Screw/Lockwasher Assy.	2	32		Retainer - Bearing	1
10	18-5190	Kit - Ball, Recirculating (Consists of 12 each of .2806 Dia. & .2812 Dia. Chrome Balls)	1	33		Ring - Valve Body	3
11		Nut - Rack Piston	1	34		O-Ring	3
12		Housing - Steering Gear	1	35	39-7310	O-Ring	3
13		Gear - Pitman Shaft	1	36		Shaft - Stub	1
14	28-8280	Seal Kit - Side Cover (Incl. Ref. #17)	1	37		O-Ring	1
15		Cover - Housing Side	1	38		Worm - Steering	1
16	28-8220	Nut - Lash Adjuster	1	39		Race - Thrust Bearing	2
17	28-8210	Bolt - Flange Hex. Hd.	4	40		Bearing - Roller, Thrust	1
18		Spool Valve	1	41	39-7440	Nut - Pitman Arm	1
19		O-Ring, Spool Valve	1	42	39-7420	Washer - Lock	1
20		Valve Body	1	43		Ring - Retaining	1
21	92-4169	Bearing - Needle	1	44		Washer - Seal, Backup	2
22		Seal - Stub Shaft	1	45		Seal - Pitman Shaft	1
23		Seal - Stub Shaft Dust	1	46		Seal - Pitman Shaft	1
				47	92-4170	Bearing - Pitman Shaft	1
				*	92-4161	Service Cover Assembly Housing Side (Incl. Ref. #14-17)	1

*Not Illustrated

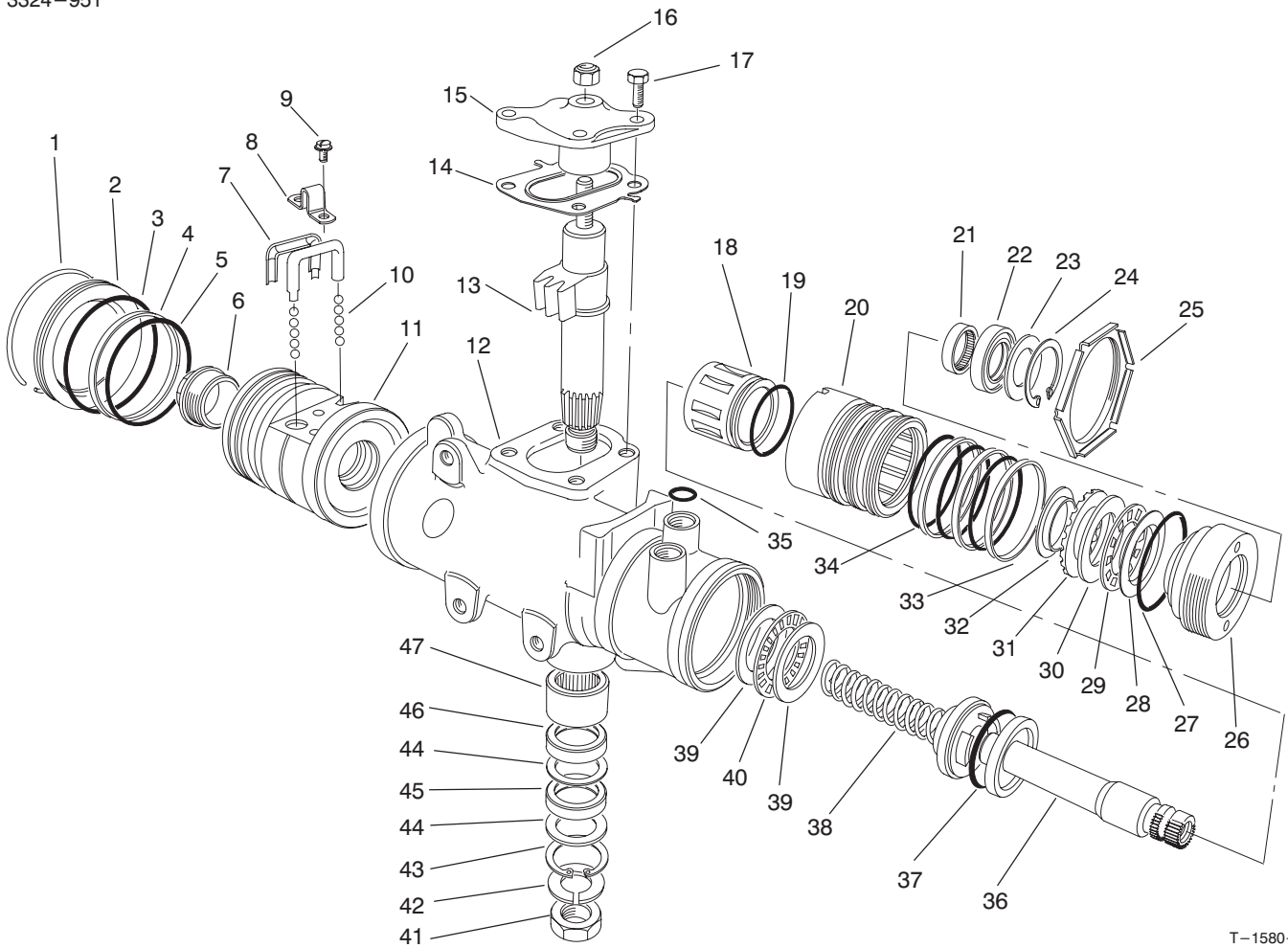

T-1580-1

STEERING GEAR ASSEMBLY NO. 87-1500

Ref. No.	Part No.	Description	No. Used
*	28-8270	Seal Service Kit - End Plug (Incl. Ref. #1 & 3)	1
*	28-8290	Seal Service Kit Rack/Piston (Incl. Ref. #4 & 5)	1
*	18-5180	Bearing Kit - Lower Thrust (Incl. Ref. #39-40)	1
*	98-2962	Seal Kit - Pitman Shaft (Incl. Ref. #43-46)	1
*	18-5170	Seal Kit - Valve Ring (Incl. Ref. #19, 33, 34 & 37)	1
*	92-4163	Steering Housing Assembly (Incl. Ref. #12 & 43-47)	1
*	92-4167	Service Plug Assembly (Incl. Ref. #22-24 & 27)	1

Ref. No.	Part No.	Description	No. Used
*	92-4162	Pitman Shaft - Gear Service (Incl. Ref. #13-14 & 17)	1
*	92-4158	Valve Assy. - Hyd. Gear (Incl. Ref. #18-20, 33, 34, 36 & 37)	1
*	92-4160	Bearing Service Kit - Upper (Incl. Ref. #28-32)	1
*	92-4166	Rack/Piston/Nut Assembly (Incl. Ref. #1-11 & 38)	1
*	92-4164	Plug Assy. - Service Adjust. (Incl. Ref. #21-24 & 26-32)	1
*	87-1500	Steering Gear (Complete)	1

*Not Illustrated

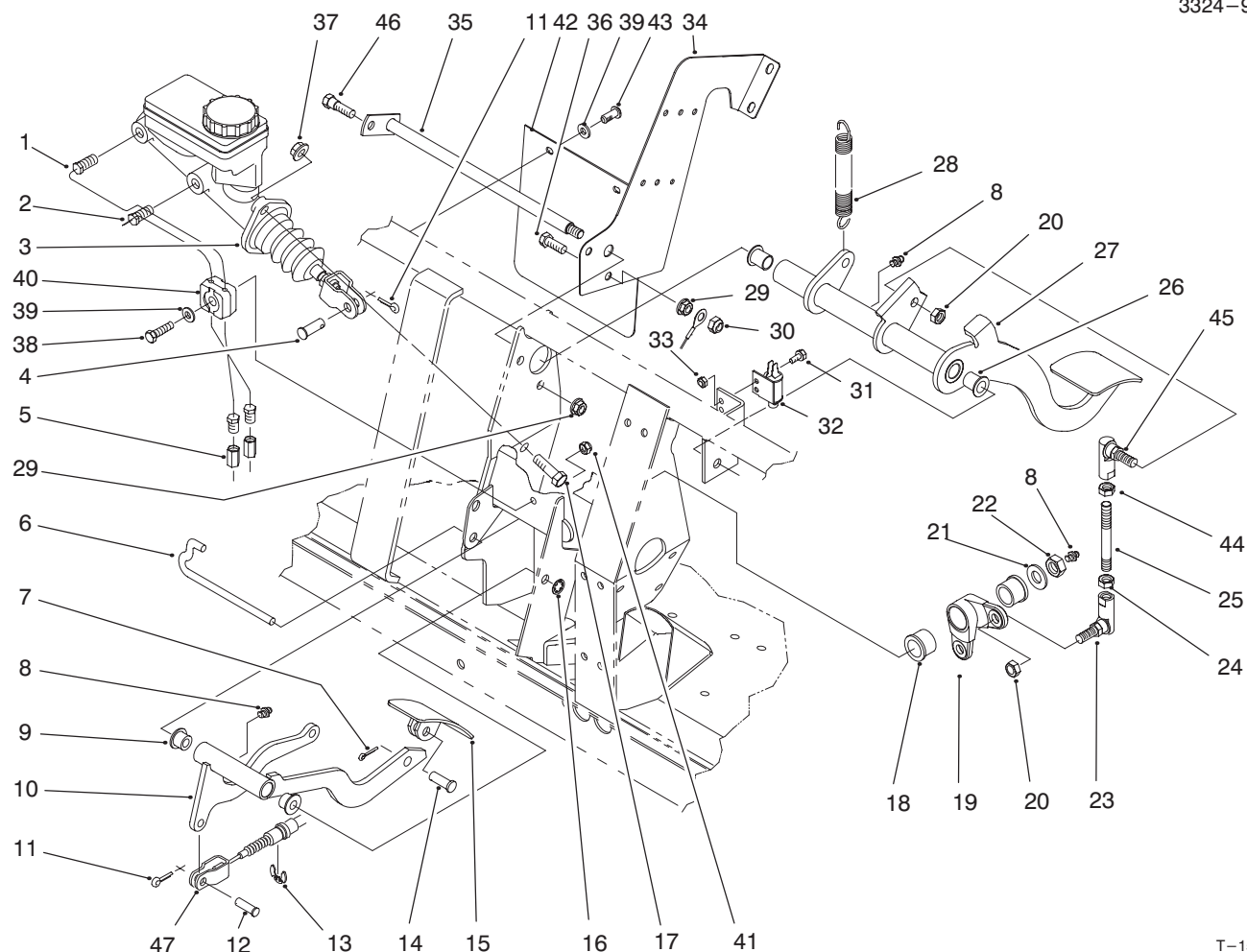

T-1585-2

BRAKE & ACCELERATOR PEDAL ASSEMBLY

Ref. No.	Part No.	Description	No. Used	Ref. No.	Part No.	Description	No. Used
1	94-3814	Tube - Hydraulic	1	25	94-5299	Rod - Link	1
2	94-3815	Tube - Hydraulic	1	26	256-155	Bushing - Flange	2
3	94-3800	Master Cylinder Assembly	1	27	93-8965-03	Pedal - Brake	1
4	283-2	Pin - Clevis	1	28	76-9430-03	Spring - Extension	1
5	87-3570	Union - Brake Line	2	29	32128-20	Nut - Flange Lock	2
6	87-2880	Shaft - Accelerator Pedal	1	30	3296-29	Nut - Lock	1
7	3272-6	Pin - Cotter	1	31	3290-321	Screw - Hex. Flange Hd.	2
8	302-5	Fitting - Grease	3	32	55-7120	Switch - Brake Light	1
9	256-259	Bushing - Flange	2	33	3296-2	Nut - Lock	2
10	93-8961-03	Arm - Accelerator Pedal	1	34	94-3821-03	Plate - Center, Frame	1
11	3272-10	Pin - Cotter	2	35	95-7394	Shaft - Brake	1
12	283-30	Pin - Clevis	1	36	322-5	Screw - Cap Hex. Hd.	1
13	32120-47	Ring - E	1	37	3290-357	Nut - Flange	2
14	283-85	Pin - Clevis	1	38	321-9	Screw - Cap Hex. Hd.	1
15	93-8969-03	Pedal - Accelerator	1	39	3256-22	Washer - Flat	3
16	32151-56	Ring - Retaining	1	40	87-7660	Clamp - Tube	2
17	323-7	Screw - Cap Hex. Hd.	2	41	3296-42	Nut - Lock	1
18	256-247	Bushing - Flange	2	42	94-5221	Flap - Master Cylinder	1
19	94-5223	Bell Crank	1	43	87-6620	Screw - Torx Pan Hd.	2
20	3296-6	Nut - Lock	2	44	3220-16	Nut - Hex. Jam	1
21	3256-26	Washer - Flat	1	45	68-3841	Ball Joint Assembly	1
22	3296-23	Nut - Lock	1	46	28-0540	Bolt - Shoulder	1
23	68-3840	Ball Joint	1	47	94-3834	Cable - Accelerator	1
24	3220-3	Nut - Hex. Jam	1				

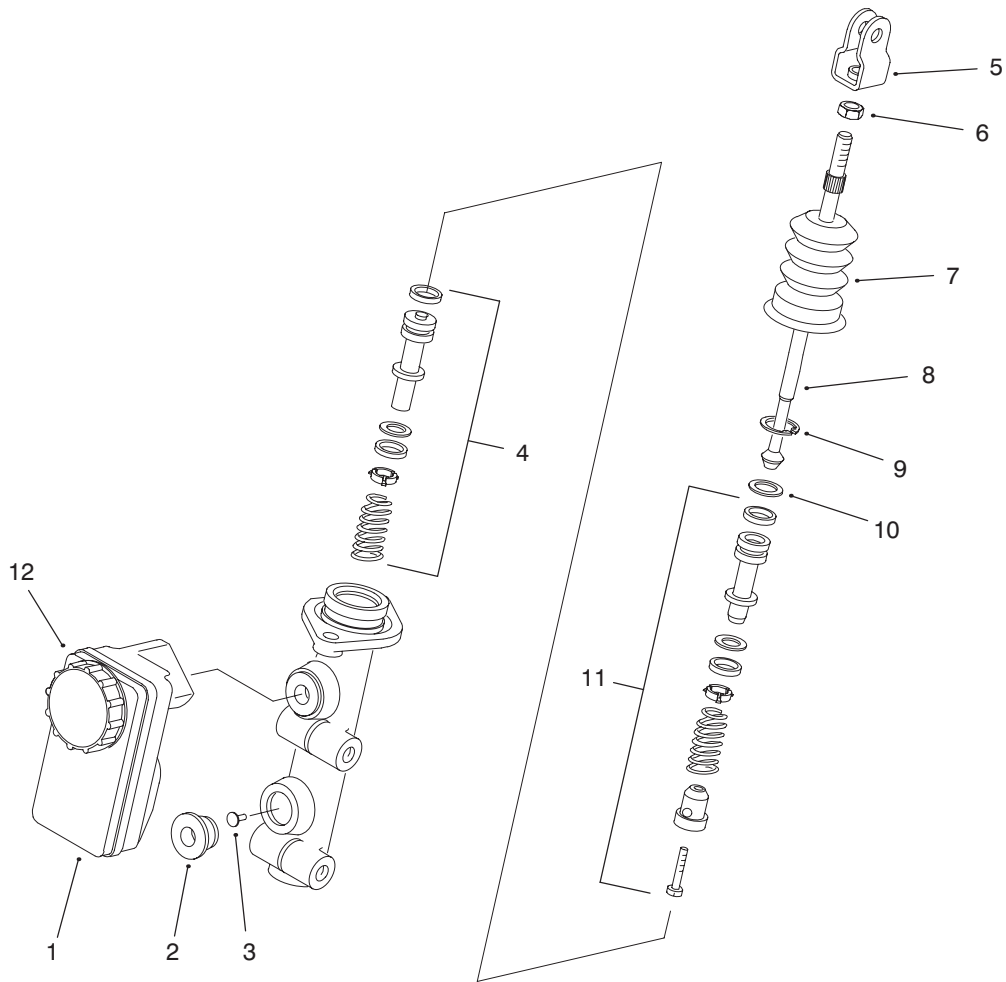

T-2339-1

MASTER BRAKE CYLINDER NO. 94-3800

Ref. No.	Part No.	Description	No. Used
1	87-3040	Reservoir - Master Cylinder (Incl. Ref. #12)	1
2	93-8971	Seal	2
3	92-4103	Pin - Stop	1
4	92-4102	Secondary Piston Assembly	1
5	92-4110	Clevis	1
6	21-0360	Nut	1

Ref. No.	Part No.	Description	No. Used
7	94-5209	Dust Cover	1
8	94-5210	Rod - Push	1
9	92-4109	Circlip	1
10	92-4108	Washer - Retainer	1
11	92-4101	Primary Piston Assembly	1
12	92-4112	Cap Assembly	1

PROTOTYPE

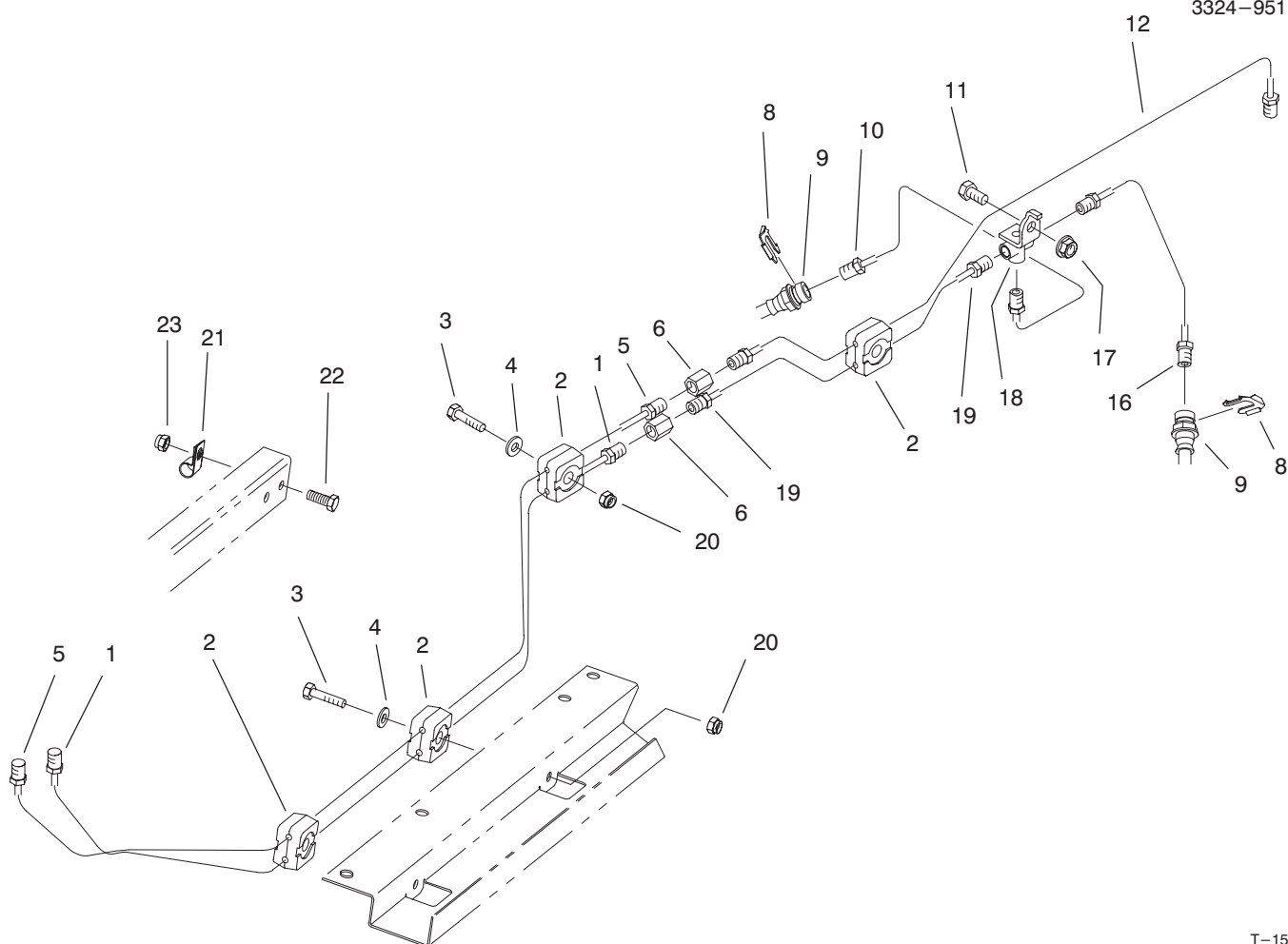

T-1587

HYDRAULIC BRAKE LINE ROUTING ASSEMBLY

Ref. No.	Part No.	Description	No. Used	Ref. No.	Part No.	Description	No. Used
1	94-3820	Tube - Brake Front	1	12	94-3842	Tube - Brake Rear	1
2	87-7660	Clamp - Brake Line	8	16	93-7082	Tube - Brake Front LH	1
3	321-9	Screw - Cap Hex. Hd.	4	17	32128-20	Nut - Flange	1
4	3256-22	Washer - Flat	4	18	87-3560	Tee - Brake Line	1
5	94-3819	Tube - Brake Rear	1	19	93-7085	Tube - Brake Front	1
6	87-3570	Fitting - Union	2	20	3296-42	Nut - Lock	4
8	87-3580	Retainer - Brake Hose	2	21	2412-89	Clamp - R	1
9	93-7123	Hose - Brake Front	2	22	321-4	Screw - Cap Hex. Hd.	1
10	93-7081	Tube - Brake Front RH	1	23	32128-33	Nut - Lock Flange	1
11	322-2	Screw - Cap Hex. Hd.	1				

HYDRAULIC SCHEMATIC

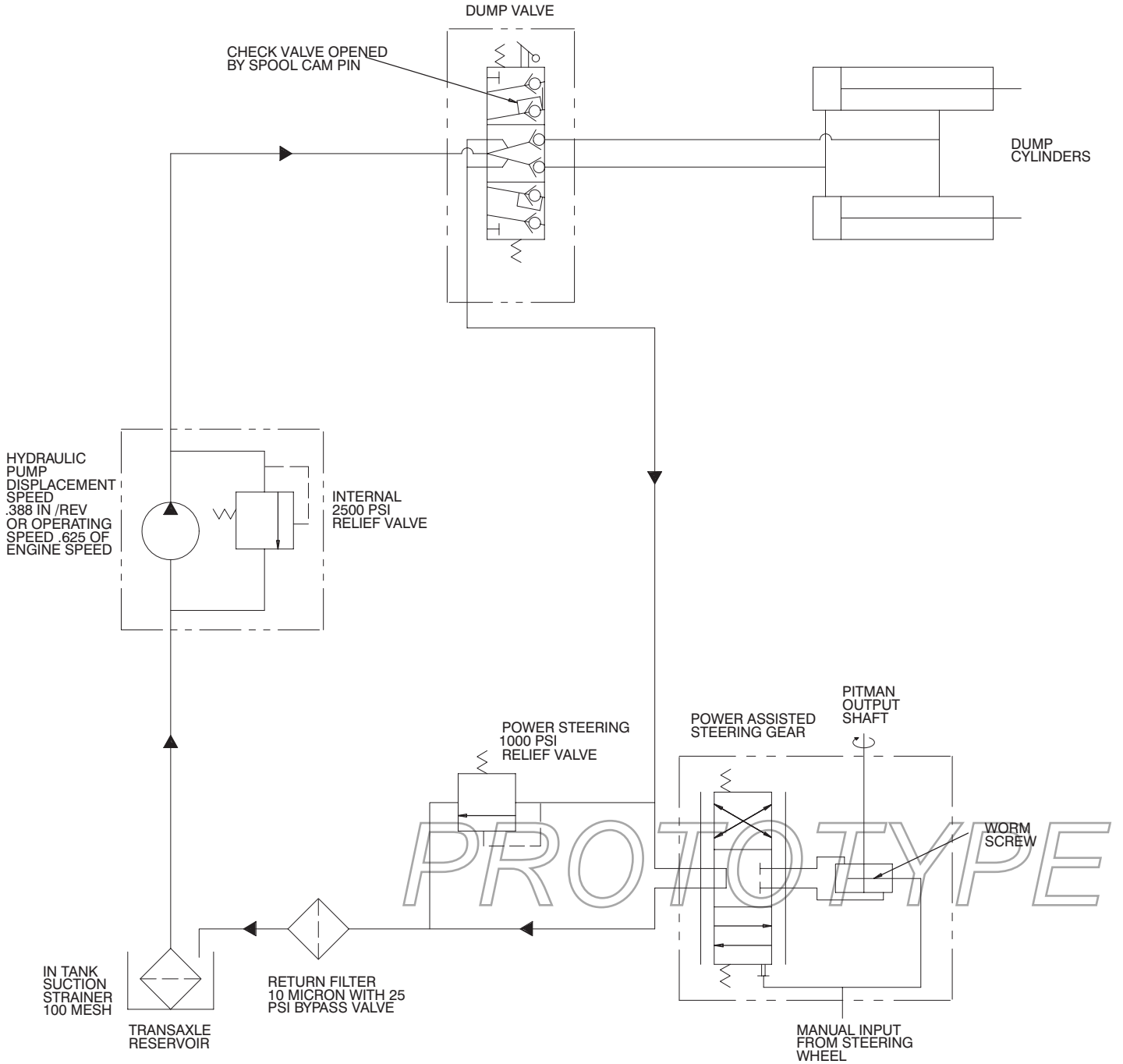

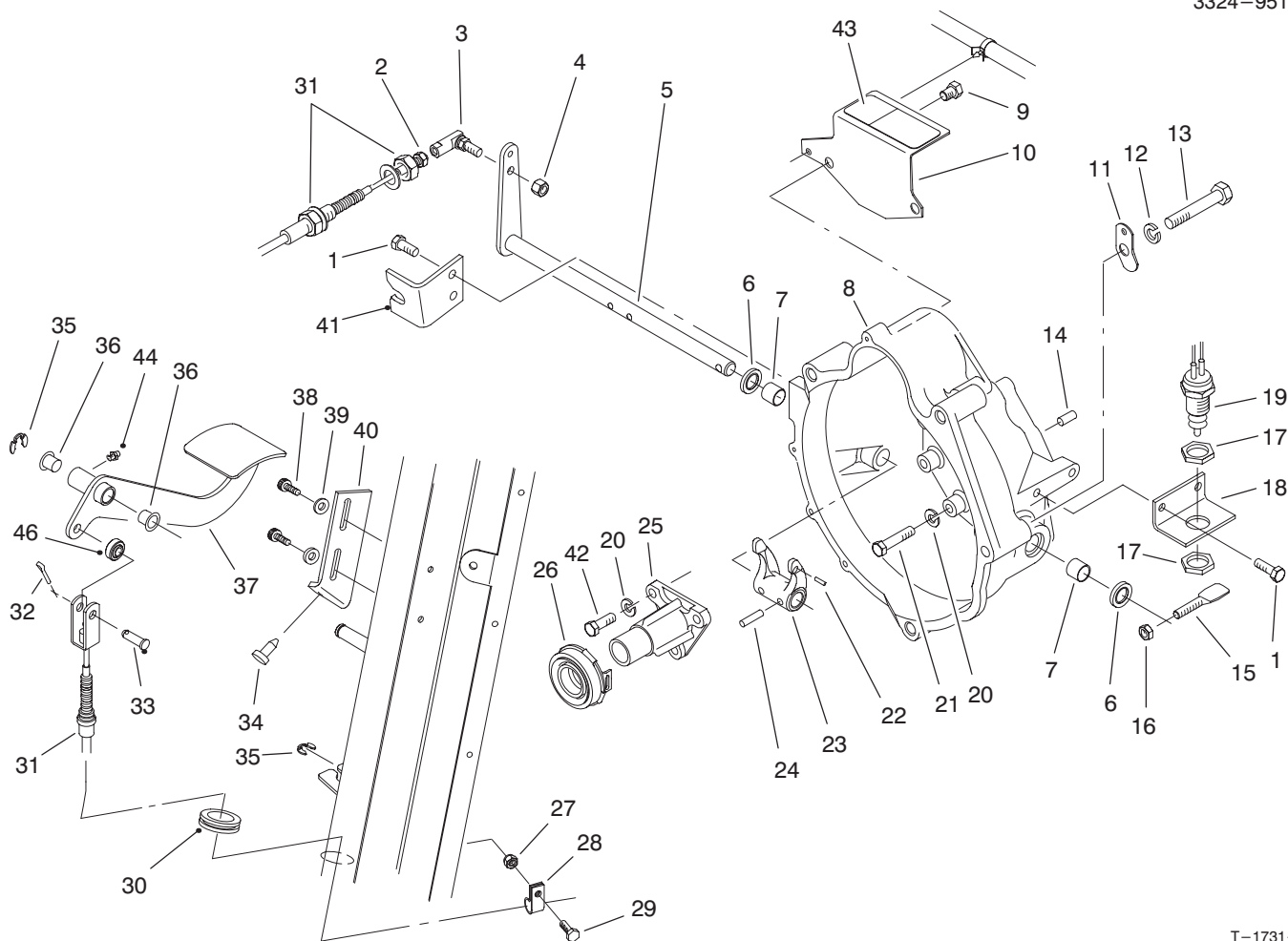

T-1731-2

CLUTCH LINKAGE ASSEMBLY

Ref. No.	Part No.	Description	No. Used	Ref. No.	Part No.	Description	No. Used
1	33114-020	Screw - Cap Hex. Hd.	4	24	32121-24	Pin - Roll	2
2	3220-2	Nut - Jam	1	25	87-5320	Guide - Release	1
3	2411-33	Joint - Ball	1	26	87-2100	Bearing - Release	1
4	3296-4	Nut - Lock	1	27	32128-33	Nut - Flange Lock	1
5	87-5290	Shaft - Release	1	28	2412-89	Clamp - R	1
6	87-1920	Seal - Shaft	2	29	321-4	Screw - Cap Hex. Hd.	1
7	87-3770	Bushing - Sleeve	2	30	240-5	Grommet	1
8	93-7121	Housing - Bell	1	31	99-1201	Clutch Cable Assembly (Incl. Ref. #2)	1
9	60-9920	Screw - Cap Hex. Hd.	2	32	3272-10	Pin - Cotter	1
10	87-8790	Starter Cover Plate Assembly (Incl. Ref. #43)	1	33	283-75	Pin - Clevis	1
11	87-6410	Bracket - Harness	1	34	87-8460	Bumper	1
12	3253-22	Washer - Lock	4	35	32120-47	Ring - E	2
13	56-2150	Screw - Cap Hex. Hd.	4	36	256-156	Bushing - Flange	2
14	87-1910	Pin - Alignment	2	37	99-1199-03	Pedal - Clutch	1
15	87-5360	Lever	1	38	87-6620	Screw - Torx Pan Hd.	2
16	3296-29	Nut - Lock	1	39	3256-22	Washer - Flat	2
17	3218-20	Nut - Jam	2	40	87-8710	Tab - Clutch	1
18	87-5350	Bracket - Switch	1	41	87-8471	Bracket - Clutch	1
19	87-5490	Switch - Neutral	1	42	33114-025	Screw - Cap Hex. Hd.	3
20	42-9850	Washer - Lock	12	43	66-6840	Decal - Hot Surface	1
21	33114-040	Screw - Cap Hex. Hd.	9	44	302-5	Fitting - Grease	1
22	32121-7	Pin - Roll	1	46	99-1202	Rod End	1
23	87-5300	Fork - Clutch	1				

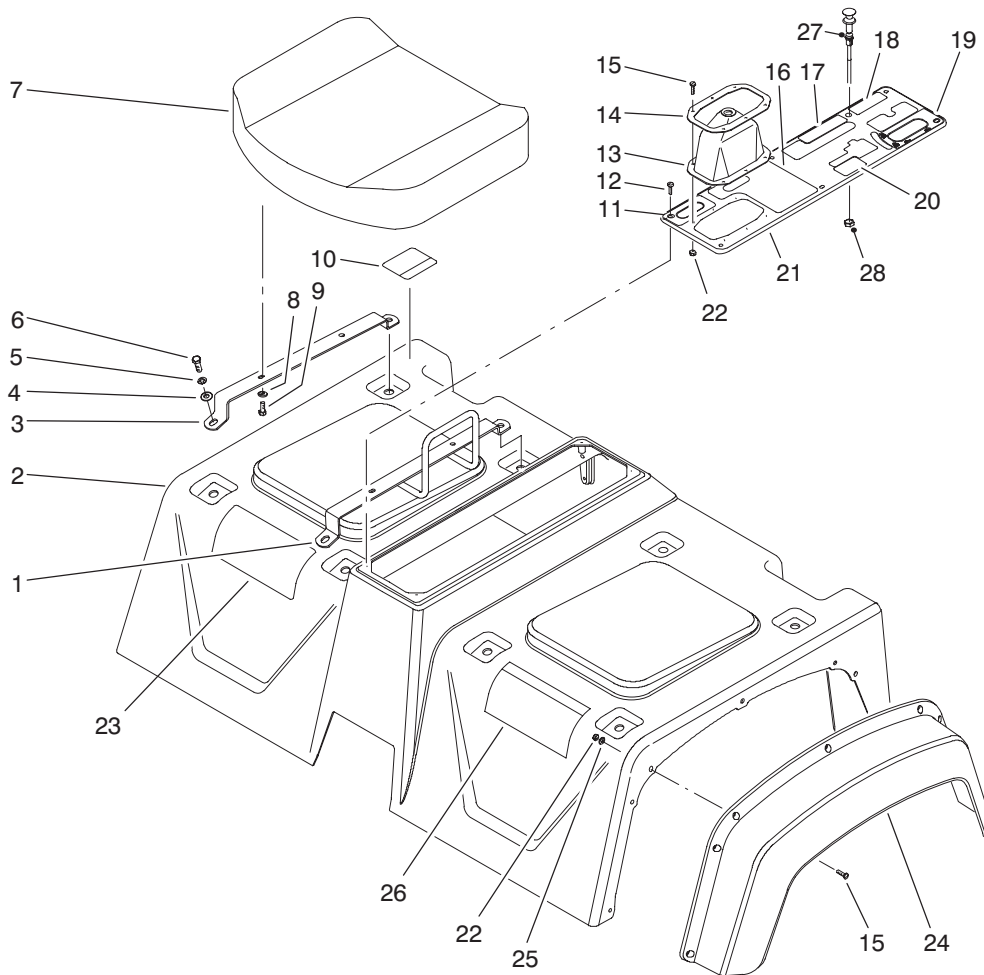

T-1589-2

SEAT BASE ASSEMBLY

Ref. No.	Part No.	Description	No. Used
1	87-6890-03	Hold - Hand	1
2	87-7070	Skirt Assembly (Incl. Ref. #10 & 26)	1
3	87-3800-03	Bracket - Seat Bottom	3
4	3256-23	Washer - Flat	4
5	3253-4	Washer - Lock	8
6	322-5	Screw - Cap Hex. Hd.	8
7	87-5060	Cushion - Seat Bottom	2
8	3256-22	Washer - Flat	8
9	321-4	Screw - Cap Hex. Hd.	8
10	87-5930	Decal - Caution	1
11	87-5960	Decal - Axle Range	1
12	32144-52	Screw - Hex. Hd.	6
13	87-8620	Boot - Shift	1
14	87-3760-03	Plate - Shift Boot	1

Ref. No.	Part No.	Description	No. Used
15	3250-13	Screw - Hex. Hd.	20
16	87-5970	Decal - PTO	1
17	87-6000	Decal - Differential Lock	1
18	92-2609	Decal - Remote Hydraulics	1
19	87-6010	Decal - Dump Hydraulics	1
20	87-6020	Decal - Parking Brake	1
21	87-8080	Console Plate Assembly (Incl. Ref. #11 & 16-20)	1
22	3296-2	Nut - Lock	20
23	93-8990	Decal - Quick Reference	1
24	87-9480	Fender - Front	2
25	3256-61	Washer - Flat	14
26	87-5920	Decal - Danger	1
27	87-8060	Choke Control Assembly	1
28	3220-3	Nut - Jam	1

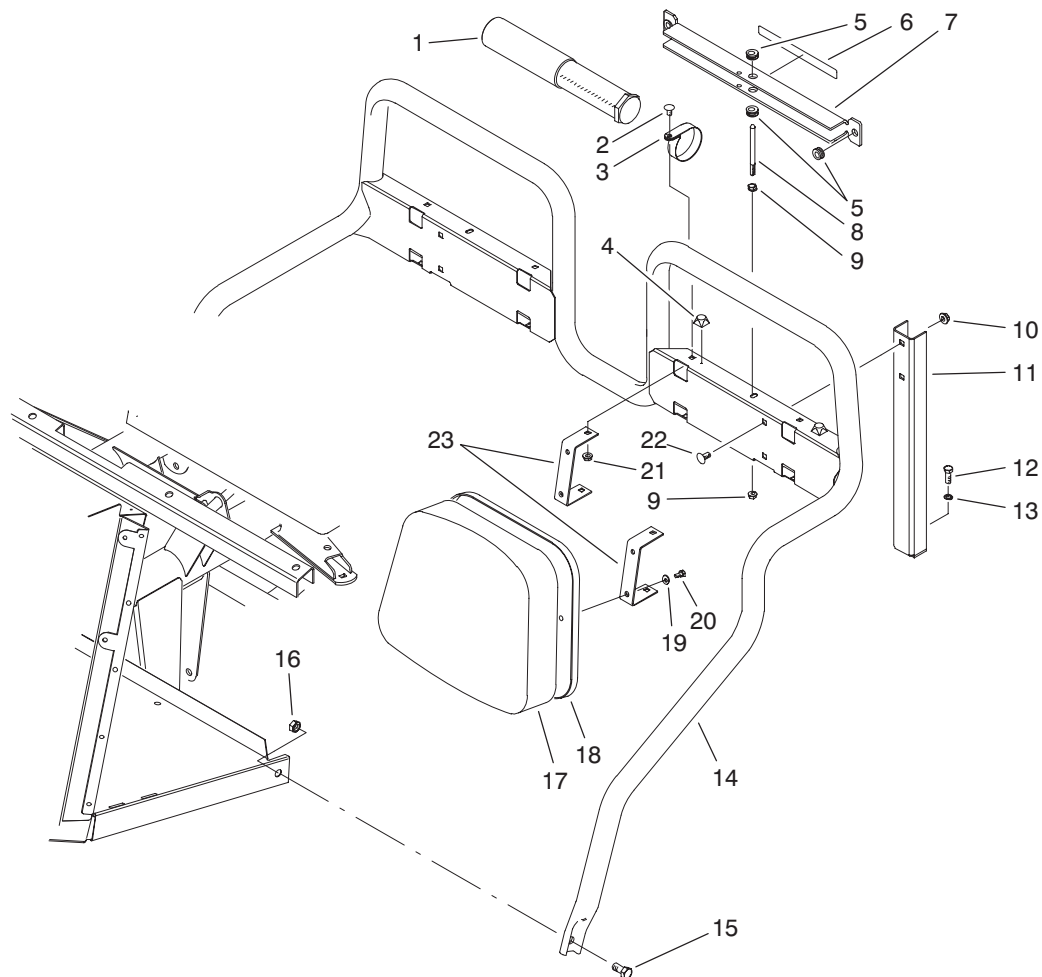

T-1779-1

SEAT BACK ASSEMBLY

Ref. No.	Part No.	Description	No. Used	Ref. No.	Part No.	Description	No. Used
1	74-0720	Tube - Manual	1	12	323-6	Screw - Cap Hex. Hd.	2
2	3230-18	Bolt - Carriage	2	13	3253-21	Washer - Lock	2
3	2412-133	R-Clamp	2	14	87-6170-03	Frame - Seat	1
4	111071	Bumper	2	15	325-4	Screw - Cap Hex. Hd.	2
5	92-5972	Grommet	4	16	3296-23	Nut - Lock	2
6	87-7930	Decal - Danger	1	17	87-6290	Cushion - Seat Back	2
7	87-7950	Bed Support Assembly (Incl. Ref. #5 & 6)	1	18	87-6280	Plate - Seat Back	2
8	87-7940	Stud	1	19	3256-22	Washer - Flat	8
9	32128-44	Nut - Flange Lock	2	20	321-4	Screw - Cap Hex. Hd.	8
10	3290-357	Nut - Flange Lock	4	21	32128-20	Nut - Flange Lock	8
11	87-2510-03	Bracket - Seat Frame	2	22	3231-21	Bolt - Carriage	4
				23	87-6240-03	Bracket - Seat Back	4

3324-951

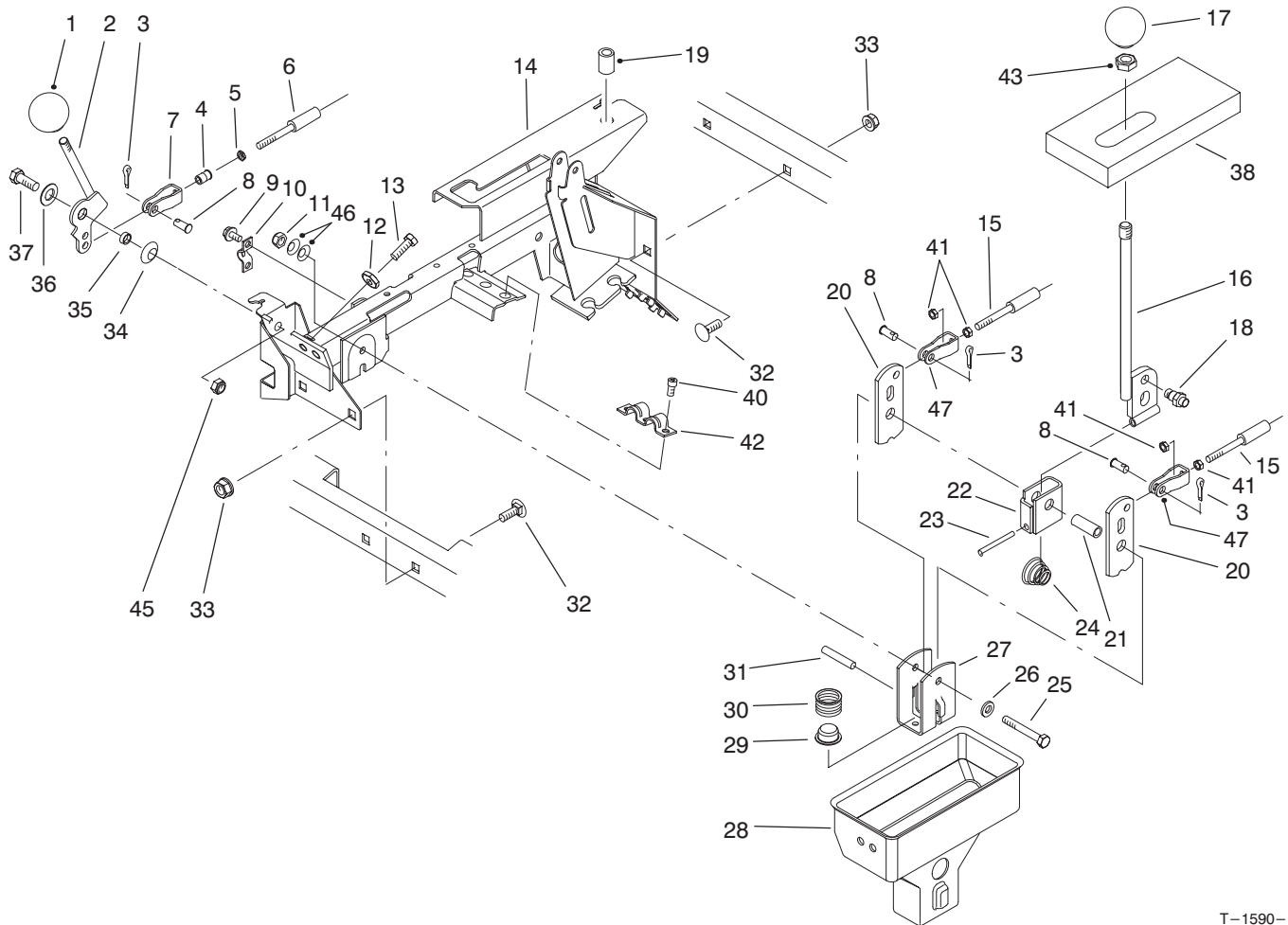

T-1590-1

HI-LO & SHIFT LEVER ASSEMBLIES

Ref. No.	Part No.	Description	No. Used
1	233-37	Knob	1
2	87-4350	Lever - Hi-Lo	1
3	3272-6	Pin - Cotter	3
4	32148-15	Insert - Threaded	1
5	3219-14	Nut	1
6	87-4420	Hi-Lo Cable Assembly (Incl. Ref. #5)	1
7	87-7160	Cable Clevis Assembly (Incl. Ref. #4)	3
8	283-62	Pin - Clevis	3
9	32144-4	Screw - Hex. Washer Hd.	2
10	87-4340	Clamp - Cable	1
11	3296-58	Nut - Lock	2
12	3220-3	Nut - Jam	2
13	3211-8	Screw - Cap Hex. Hd.	2
14	94-5202	Lever Support Assembly (Incl. Ref. #19)	1
15	87-4260	Cable Assembly (Incl. Ref. #41)	2
16	87-2040	Lever - Shift	1
17	87-6720	Knob	1
18	87-3650	Pin - Shift	1
19	32148-7	Nut - Clinch	2
20	87-3540	Link - Shift	2

Ref. No.	Part No.	Description	No. Used
21	87-2520	Tube - Pivot	1
22	87-6040	Bracket - Shifter	1
23	32121-48	Pin - Roll	1
24	87-2900	Spring - Compression	1
25	322-12	Screw - Cap Hex. Hd.	1
26	87-8640	Washer - Flat	1
27	87-3520	Clevis	1
28	87-2260	Boot - Shift Lower	1
29	87-3530	Button - Shifter	1
30	87-3660	Spring - Compression	1
31	3290-507	Pin - Dowel	1
32	3231-21	Bolt - Carriage	4
33	3290-357	Nut - Flange Lock	4
34	3290-221	Washer - Spring	1
35	76-9100	Spacer - Hi-Lo Lever	1
36	49-9150	Washer - Flat	1
37	323-6	Screw - Cap Hex. Hd.	1
38	87-6570	Foam - Seal	1
40	65-5220	Screw - Hex. Socket Hd.	3
41	3220-1	Nut - Jam	4
42	87-4960	Clamp - Cable	1
43	3218-18	Nut - Jam	1
45	3296-39	Nut - Lock	1
46	3290-456	Washer - Belleville	2

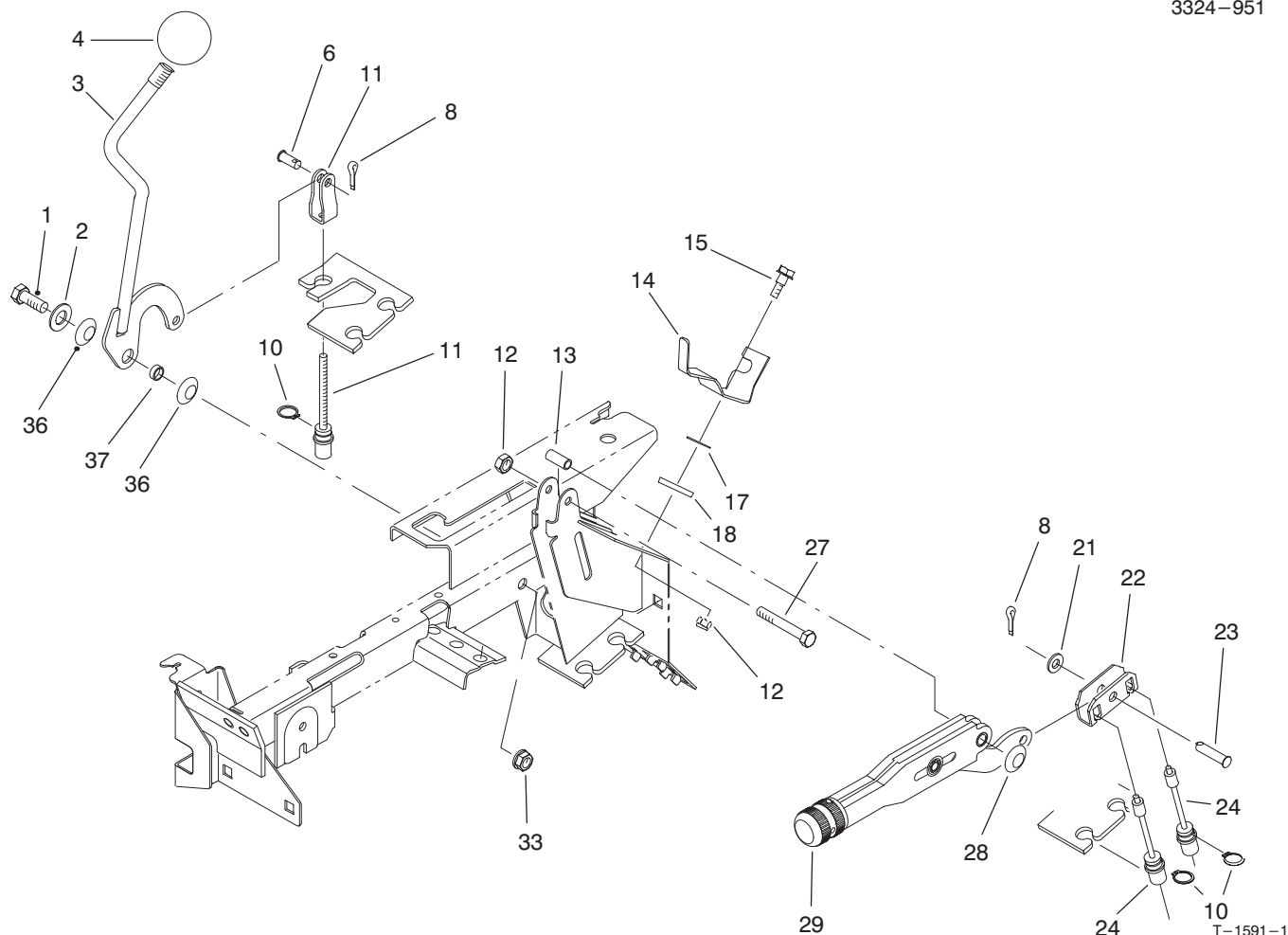

DIFFERENTIAL LOCK & PARKING BRAKE ASSEMBLIES

Ref. No.	Part No.	Description	No. Used
1	323-6	Screw - Cap Hex. Hd.	1
2	49-9150	Washer - Flat	1
3	87-5030	Lever - Differential Lock	1
4	233-48	Knob	1
6	283-62	Pin - Clevis	1
8	3272-6	Pin - Cotter	2
10	32120-47	Ring - Retaining	3
11	87-4460	Differential Lock Cable	1
12	3296-42	Nut - Lock	2
13	87-4710	Spacer - Parking Brake	1
14	87-6640-03	Lever - Dump Stop	1
15	42-3560	Screw - Shoulder	1

Ref. No.	Part No.	Description	No. Used
17	3290-478	Washer - Belleville	1
18	71-5320	Washer - Flat	1
21	3256-23	Washer - Flat	1
22	87-3480	Plate - Brake Equalizer	1
23	94-3829	Pin - Clevis	1
24	87-8240	Cable - Parking Brake	2
27	321-9	Screw - Cap Hex. Hd.	1
28	3290-477	Washer - Curved	1
29	87-2710	Lever - Parking Brake	1
33	3296-39	Nut - Lock	1
36	3290-221	Washer - Spring	2
37	76-2290	Spacer	1

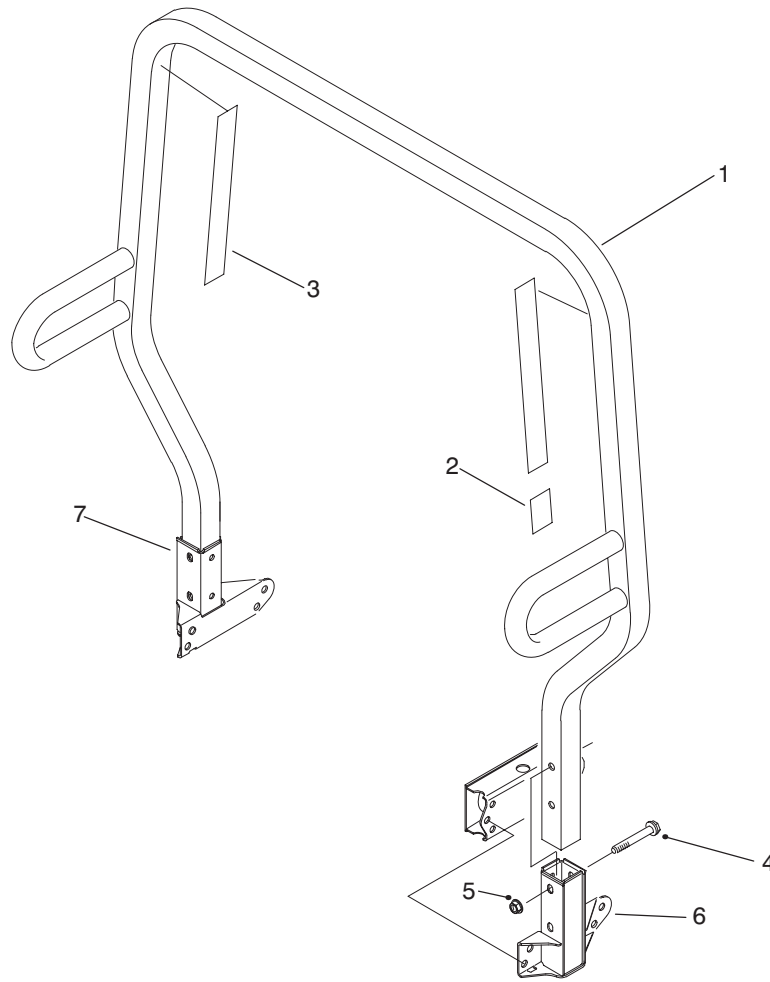

T-1592-1

R.O.P.S. ASSEMBLY

Ref. No.	Part No.	Description	No. Used
1	87-7090	R.O.P.S. Frame Assembly (Incl. Ref. #2 & 3)	1
2	87-5940	Decal - Rollover	1
3	87-5980	Decal - ROPS	2

Ref. No.	Part No.	Description	No. Used
4	3234-40	Screw - Hex. Flange Hd.	4
5	32128-23	Nut - Flange Lock	4
6	87-6950-03	Receiver - LH	1
7	87-6960-03	Receiver - RH	1

PROTOTYPE

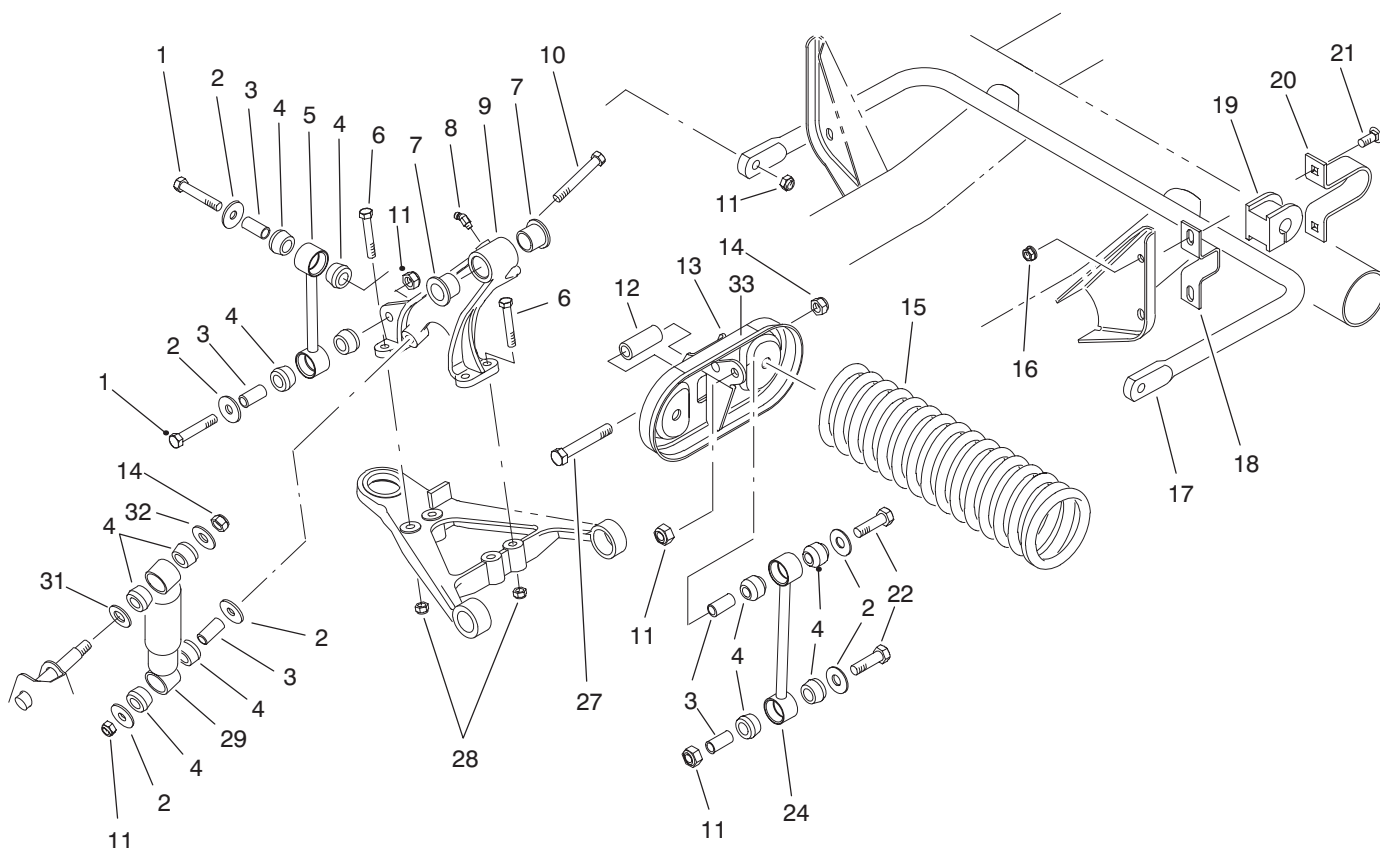

T-1593-1

FRONT SUSPENSION ASSEMBLY

Ref. No.	Part No.	Description	No. Used	Ref. No.	Part No.	Description	No. Used
1	324-10	Screw - Cap Hex. Hd.	4	15	87-0690-03	Spring - Compression	2
2	87-5330	Washer	12	16	3290-357	Nut - Flange Lock	4
3	87-3600	Spacer	10	17	87-3850-03	Bar - Anti-Sway	1
4	87-3920	Bushing - Rubber	24	18	87-3890-03	Bracket - Anti-Sway Bar	2
5	87-3860-03	Link - Anti-Sway Bar	2	19	87-3910	Bushing - Anti-Sway Bar	2
6	323-12	Screw - Cap Hex. Hd.	8	20	87-4010-03	Clamp - Anti-Sway Bar	2
7	33-3090	Bushing - Flange	4	21	3231-25	Bolt - Carriage	4
8	302-11	Fitting - Grease	2	22	324-9	Screw - Cap Hex. Hd.	4
9	87-0150-03	Tower - Control Arm RH	1	24	87-2480-03	Link - Stabilizer	2
*	87-0160-03	Tower - Control Arm LH	1	27	325-13	Screw - Cap Hex. Hd.	4
10	324-13	Screw - Cap Hex. Hd.	2	28	3296-39	Nut - Lock	8
11	3296-48	Nut - Lock	10	29	87-3110	Absorber - Shock	2
12	87-2500	Sleeve - Spring Pivot	2	31	3256-27	Washer - Flat	2
13	87-7150	Spring Cradle Assembly (Incl. Ref. #33)	2	32	3256-6	Washer - Flat	2
14	3296-23	Nut - Lock	4	33	44-0760	Decal - Warning	2

*Not Illustrated

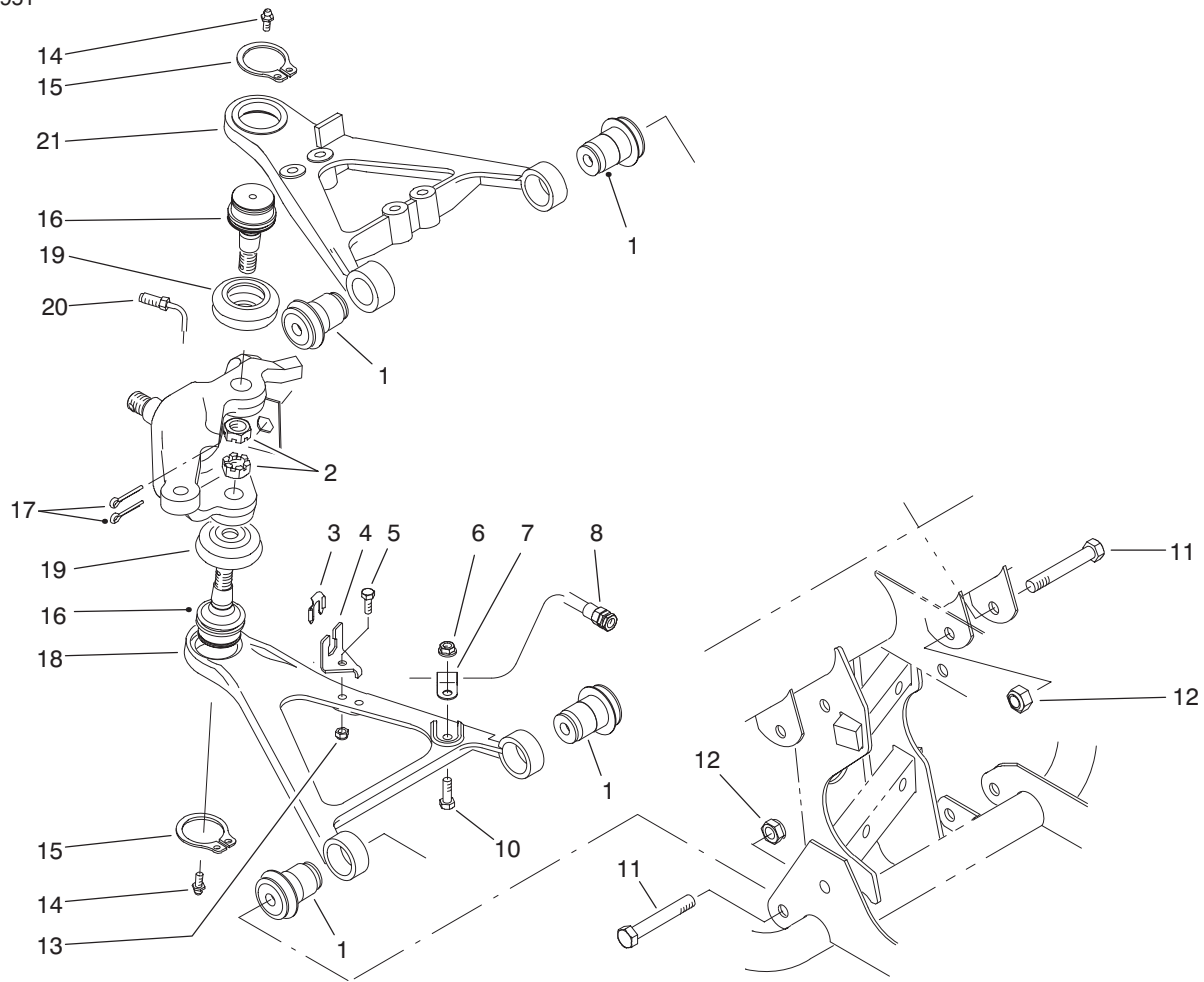

T-1594-1

FRONT SUSPENSION CONTROL ARM ASSEMBLY

Ref. No.	Part No.	Description	No. Used
1	87-1450	Bushing - Rubber	8
2	32136-2	Nut - Slotted	4
3	87-3580	Retainer - Brake Hose	2
4	87-2870	Bracket - Brake Hose	2
5	321-6	Screw - Cap Hex. Hd.	2
6	32128-20	Nut - Flange Lock	2
7	2412-10	Clamp - R	2
8	93-7123	Hose - Brake Front	2
10	322-5	Screw - Cap Hex. Hd.	2
11	325-13	Screw - Cap Hex. Hd.	8
12	3296-23	Nut - Flange Lock	8
13	3296-42	Nut - Lock	2

Ref. No.	Part No.	Description	No. Used
14	302-5	Fitting - Grease	4
15	32151-104	Ring - Snap	4
16	87-1430	Joint - Ball	4
17	3272-12	Pin - Cotter	4
18	87-0210-03	Arm - Control Lower RH	1
*	87-0220-03	Arm - Control Lower LH	1
19	87-2420	Boot	4
20	87-2800	Tube - Brake RH	1
*	87-2790	Tube - Brake LH	1
21	93-7135-03	Arm - Control Upper RH	1
*	93-7133-03	Arm - Control Upper LH	1

*Not Illustrated

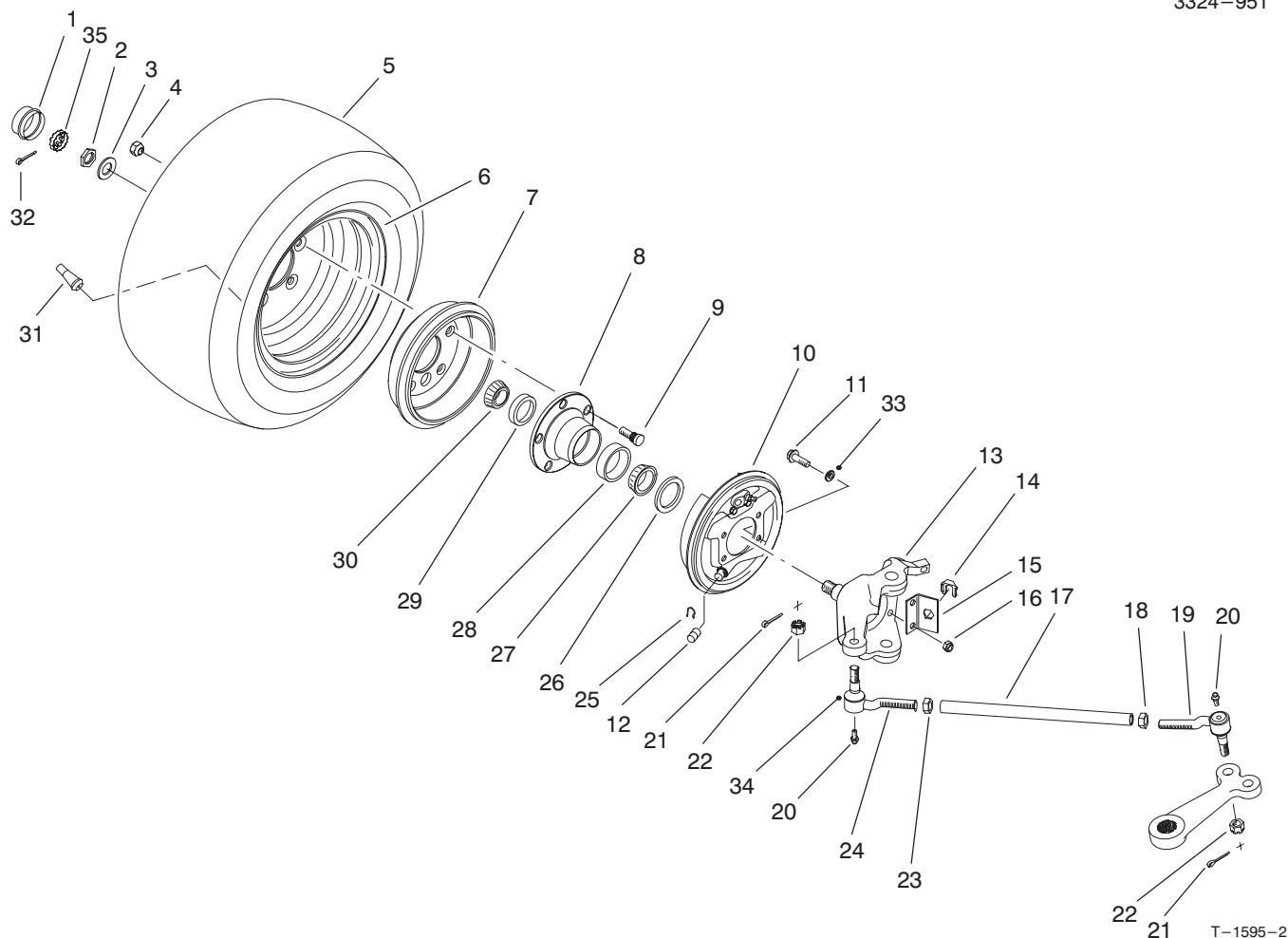

FRONT WHEEL ASSEMBLY

Ref. No.	Part No.	Description	No. Used
1	241-119	Cap Dust	2
2	32136-5	Nut Slotted	2
3	3256-28	Washer - Flat	2
4	23-7270	Nut - Lug	10
5	94-5261	Tire	2
*	Optional	Tire-Hard Surface & Traction Options (See Dealer/Distributor for Tire Selection Guide)	2
6	87-5720	Rim	2
7	87-0270	Drum - Brake	2
8	87-5560	Hub - Wheel	2
9	87-8730	Stud - Drive	10
10	87-3010	Brake Assembly - RH	1
*	87-3020	Brake Assembly - LH	1
11	323-8	Screw - Hex. Flange Hd.	8
12	87-3450	Plug	2
13	87-5520	Spindle - RH	1
*	87-5540	Spindle - LH	1
14	87-3580	Retainer	2
15	87-2820	Bracket - Hose	2
16	3296-39	Nut - Lock	8
17	87-2410-03	Rod - Tie	2
18	3218-21	Nut - Jam	2

Ref. No.	Part No.	Description	No. Used
19	87-1470-03	Rod End Assy. - LH Thread (Incl. Ref. # 20-22 & 34)	2
*	94-3804	Rod End Assy. - LH Thread Heavy Duty (Optional)	2
20	302-5	Fitting - Grease	4
21	3272-12	Pin - Cotter	4
22	32136-3	Nut - Slotted	4
23	3220-11	Nut - Jam	2
24	87-1480-03	Rod End Assy. - RH Thread (Incl. Ref. #20-22 & 34)	2
*	94-3807	Rod End Assy. - RH Thread Heavy Duty (Optional)	2
25	87-3310	Clip - Brake Cable	2
26	87-3590	Seal - Bearing	2
27	254-106	Cone - Bearing	2
28	254-107	Cup - Bearing	2
29	254-72	Cup - Bearing	2
30	254-94	Cone - Bearing	2
31	232-27	Stem - Valve	2
32	3272-12	Pin - Cotter	2
33	3253-21	Washer - Lock	8
34		Seal - Rod	4
35	93-0307	Nut - Retainer	2
*	87-5340	Seal Kit - Tie Rod End (Incl. Ref. #20-22 & 34)	1

*Not Illustrated

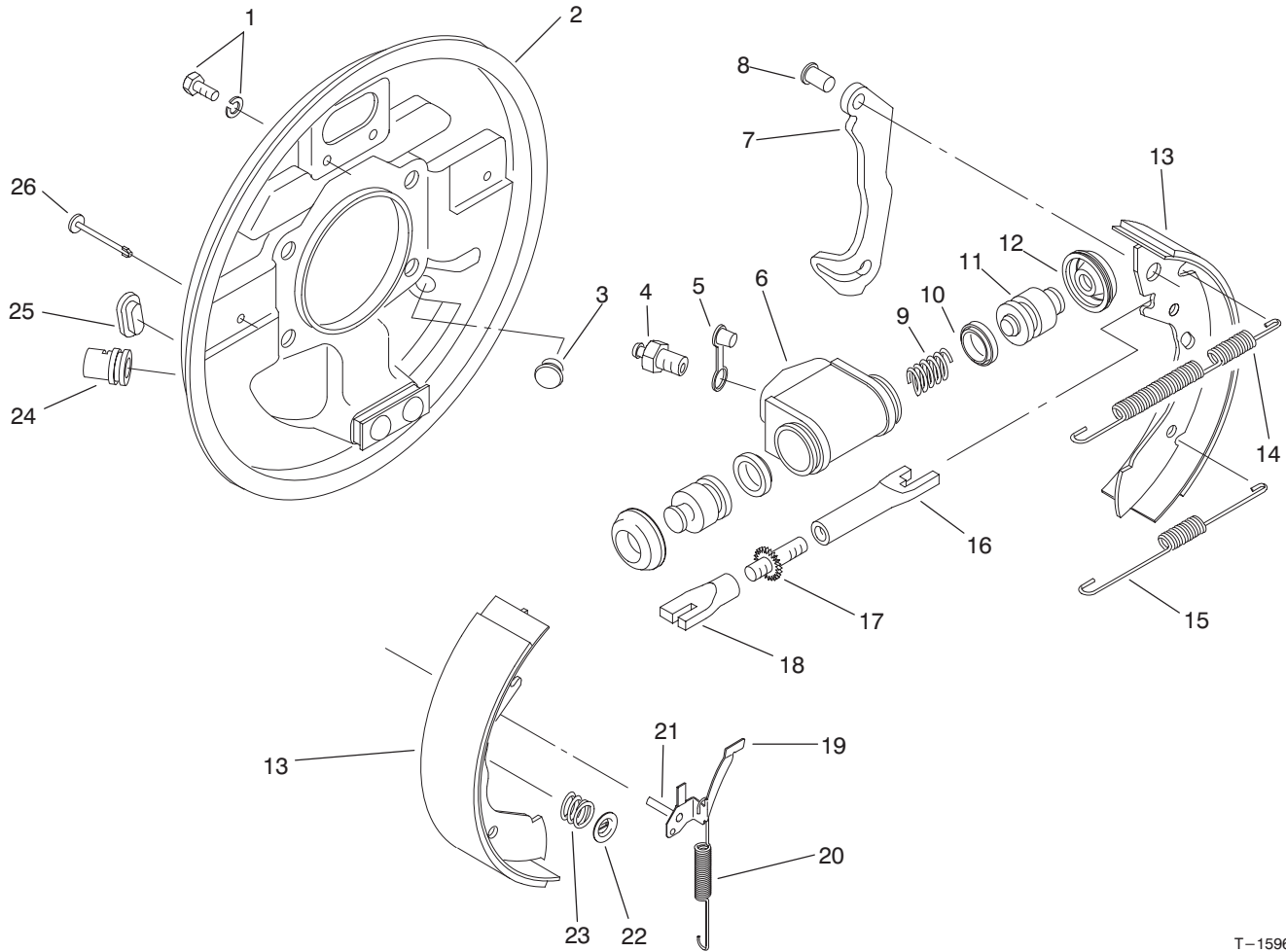

T-1596-1

FRONT BRAKE ASSEMBLY

Ref. No.	Part No.	Description	No. Used	Ref. No.	Part No.	Description	No. Used
1	92-4135	Set Bolt	2	19	92-4123	Pawl Assembly - LH (Incl. Ref. #21)	1
2	92-4115	Backplate Assembly LH (Incl. Ref. #24)	1	*	92-4124	Pawl Assembly - RH (Incl. Ref. #21)	1
*	92-4116	Backplate Assembly RH (Incl. Ref. #24)	1	20	92-4129	Spring - Adjuster, LH	1
3	92-4125	Plug	1	*	92-4130	Spring - Adjuster, RH	1
4	92-4113	Screw - Bleed	1	21		Pin - Pawl	1
5	92-4114	Cap - Bleed Screw	1	22	92-4131	Washer - Hold Down	2
6		Body	1	23	92-4132	Spring - Hold Down	2
7		Lever - Operating LH/RH	1	24		Guide - Pipe	1
8		Pin	1	25	92-4134	Plug - Inspection	1
9		Spring	1	26	92-4133	Pin - Hold Down	2
10		Seal - 'L' Type	2	*	92-4121	Adjuster Assembly - LH (Incl. Ref. #16-18)	1
11		Piston	2	*	92-4122	Adjuster Assembly - RH (Incl. Ref. #16-18)	1
12		Cover - Dust	2	*	92-4117	Wheel Cylinder Assy. - LH (Incl. Ref. #4-6 & 9-12)	1
13	92-4120	Shoe & Lining Set (4 Shoes) (Incl. Ref. #7 & 8)	1	*	92-4118	Wheel Cylinder Assy. - RH (Incl. Ref. #4-6 & 9-12)	1
14	92-4126	Spring - Shoe, Upper LH	1	*	92-4119	Kit - Seal (Incl. Ref. #10 & 12)	1
*	92-4127	Spring - Shoe, Upper RH	1	*	87-3010	Front Brake Assembly - RH (Complete)	1
15	92-4128	Spring - Shoe, Lower	1	*	87-3020	Front Brake Assembly - LH (Complete)	1
16		Pushrod - Female LH	1				
*		Pushrod - Female RH	1				
17		Bolt - Adjuster	1				
18		Sleeve - Adjuster	1				

*Not Illustrated

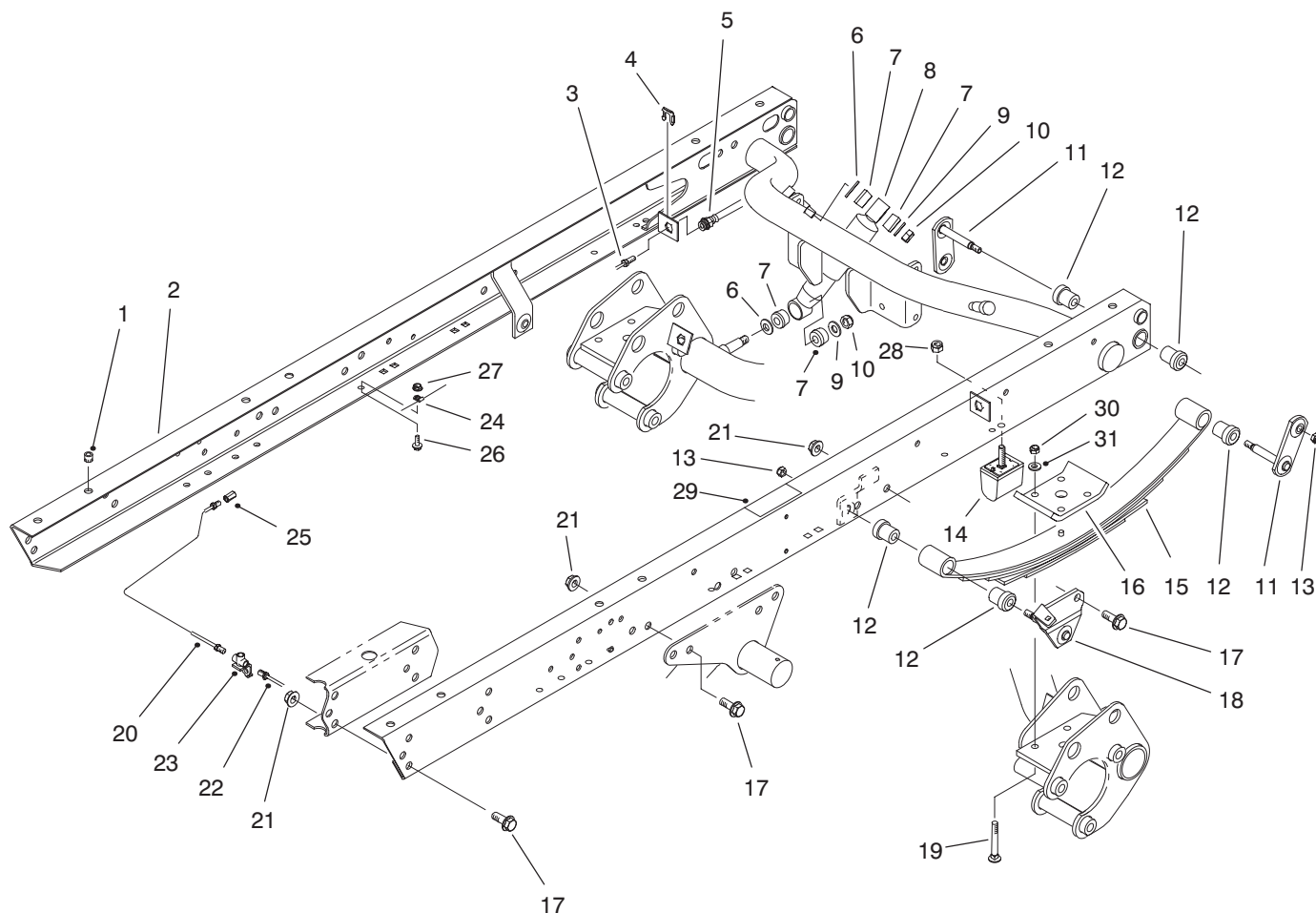

T-1778-1

REAR FRAME ASSEMBLY

Ref. No.	Part No.	Description	No. Used	Ref. No.	Part No.	Description	No. Used
1	32148-9	Insert - Threaded	8	17	3234-38	Screw - Hex. Flange Hd.	24
2	87-8440	Rear Frame Assembly (Incl. Ref. #32)	1	18	87-3960	Mount - Spring LH	1
3	94-3846	Tube - Brake RH	1	*	87-3940	Mount - Spring RH	1
4	87-3580	Retainer	2	19	3232-17	Bolt - Carriage	8
5	87-4100	Hose - Brake	2	20	94-3845	Tube - Hydraulic	1
6	3256-27	Washer - Flat	8	21	32128-23	Nut - Flange Lock	24
7	87-3920	Bushing - Rubber	8	22	94-3843	Tube - Brake LH	1
8	87-3110	Shock Absorber	2	23	87-3560	Tee - Brake Tube	1
9	3256-6	Washer - Flat	4	24	2412-149	Clamp - Tube	4
10	3296-23	Nut - Lock	4	25	87-3570	Union - Brake	2
11	87-3980	Shackle - Spring	4	26	3234-4	Screw - Cap Hex. Hd.	3
12	87-4760	Bushing	12	27	32128-33	Nut - Flange Lock	4
13	3296-39	Nut - Lock	6	28	48-9520	Nut - Lock	2
14	87-3470	Bumper - Spring	2	32	66-6840	Decal - Caution	1
15	87-1490	Spring - Leaf	2	33	3296-76	Nut - Lock	8
16	87-7470-03	Plate - Clamp	2	34	87-7480	Washer - Flat	8

*Not Illustrated

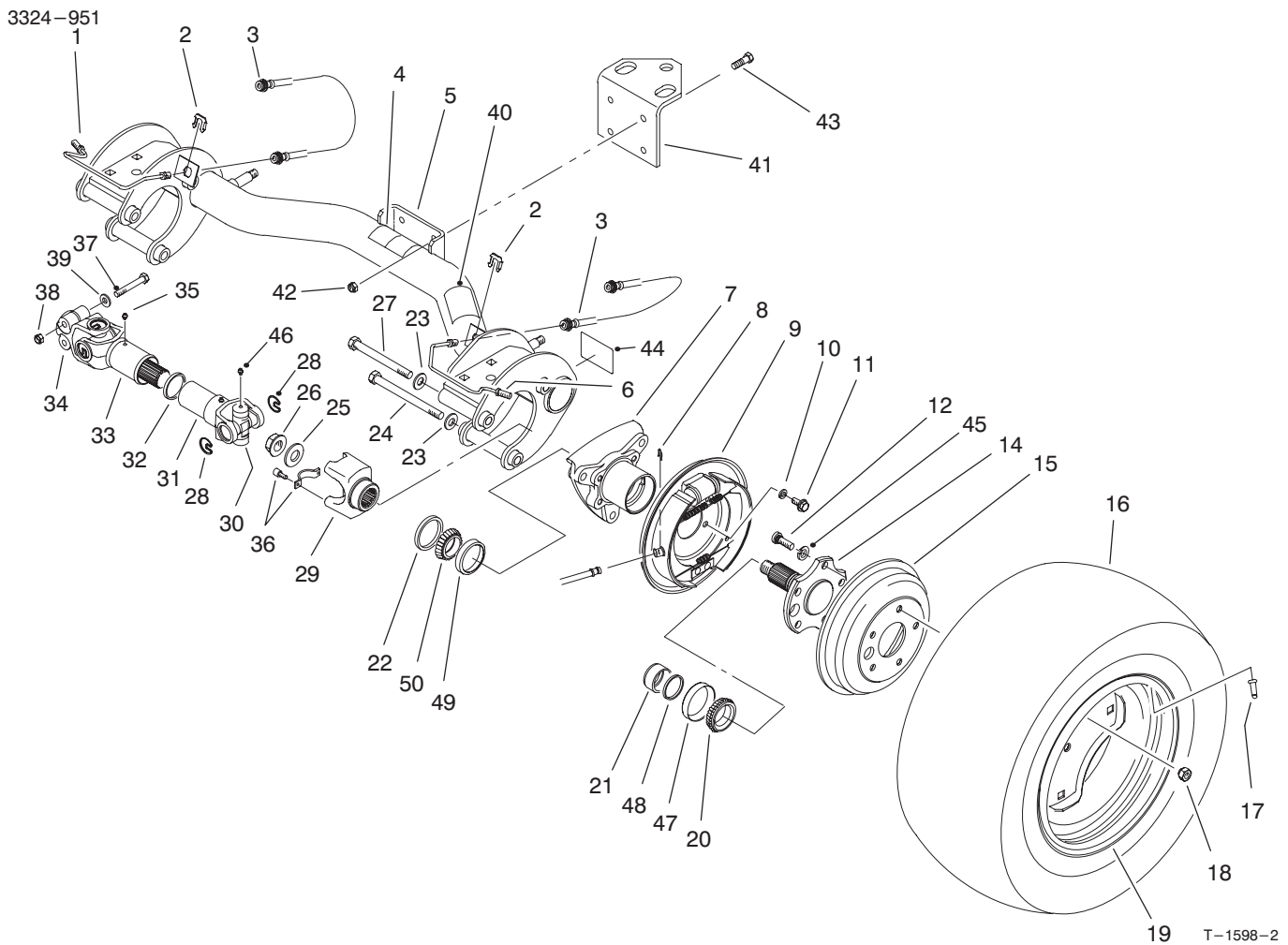

REAR AXLE ASSEMBLY

Ref. No.	Part No.	Description	No. Used
1	87-4090	Tube - Brake RH	1
2	87-3580	Retainer - Brake Hose	2
3	87-4100	Hose - Brake	2
4	87-6060	Decal - ATF	1
5	87-7110	Rear Axle Assembly (Incl. Ref. #4, 39 & 43)	1
6	87-4080	Tube - Brake LH	1
7	87-2240-03	Housing - Axle	2
8	87-3310	Clip - Brake Cable	2
9	93-7126	Brake Assembly LH	1
*	93-7125	Brake Assembly RH	1
10	3253-21	Washer - Lock	8
11	323-6	Screw - Cap Hex. Hd.	8
12	87-2080	Stud - Drive	10
14	93-7090-03	Stub - Axle	2
15	87-1840	Drum - Brake	2
16	87-3290	Tire - Rear 23"	2
*	Optional	Tire - Hard Surface & Traction Options (See Dealer/Distributor for Tire Selection Guide)	2
17	232-27	Valve - Stem	2
18	23-7270	Nut - Lug	10
19	87-3000	Rim - Rear 23"	2
*	87-6750	Rim - Rear 24" (Optional)	2
†20		Cone - Bearing	1

Ref. No.	Part No.	Description	No. Used
21	87-4060	Spacer - Bearing	2
22	87-3590	Seal - Bearing	2
23	87-7270	Washer - Flat	6
24	325-20	Screw - Cap Hex. Hd.	5
25	87-3060	Washer - Flat	2
26	32128-53	Nut - Flange Lock	2
27	325-19	Screw - Cap Hex. Hd.	1
28	92-4188	Ring - Snap	16
29	92-4190	Yoke - End	2
30	92-4187	Cross & Bearing Kit	4
31	92-4182	Yoke & Hub	2
32	92-4180	Seal	2
33	92-4179	Yoke, Shaft & Seal Tube	2
34	98-2940	Yoke - Double Clamp	2
35	302-5	Fitting - Grease	2
36	92-4189	Strap & Bolt Kit	2
37	98-2939	Screw - Cap Hex. Hd.	4
38	32128-36	Nut - Lock	4
39	80-6990	Washer	4
40	87-5990	Decal - PTO	1
41	92-5951-03	Angle - Hitch	1
42	3296-39	Nut - Lock	4
43	323-7	Screw - Cap Hex. Hd.	4
44	87-9080	Decal - Grease	2
45	3253-6	Washer - Lock	10
46	302-58	Fitting - Grease	16
47†		Cup - Bearing	1

*Not Illustrated

†Not Serviced Separately

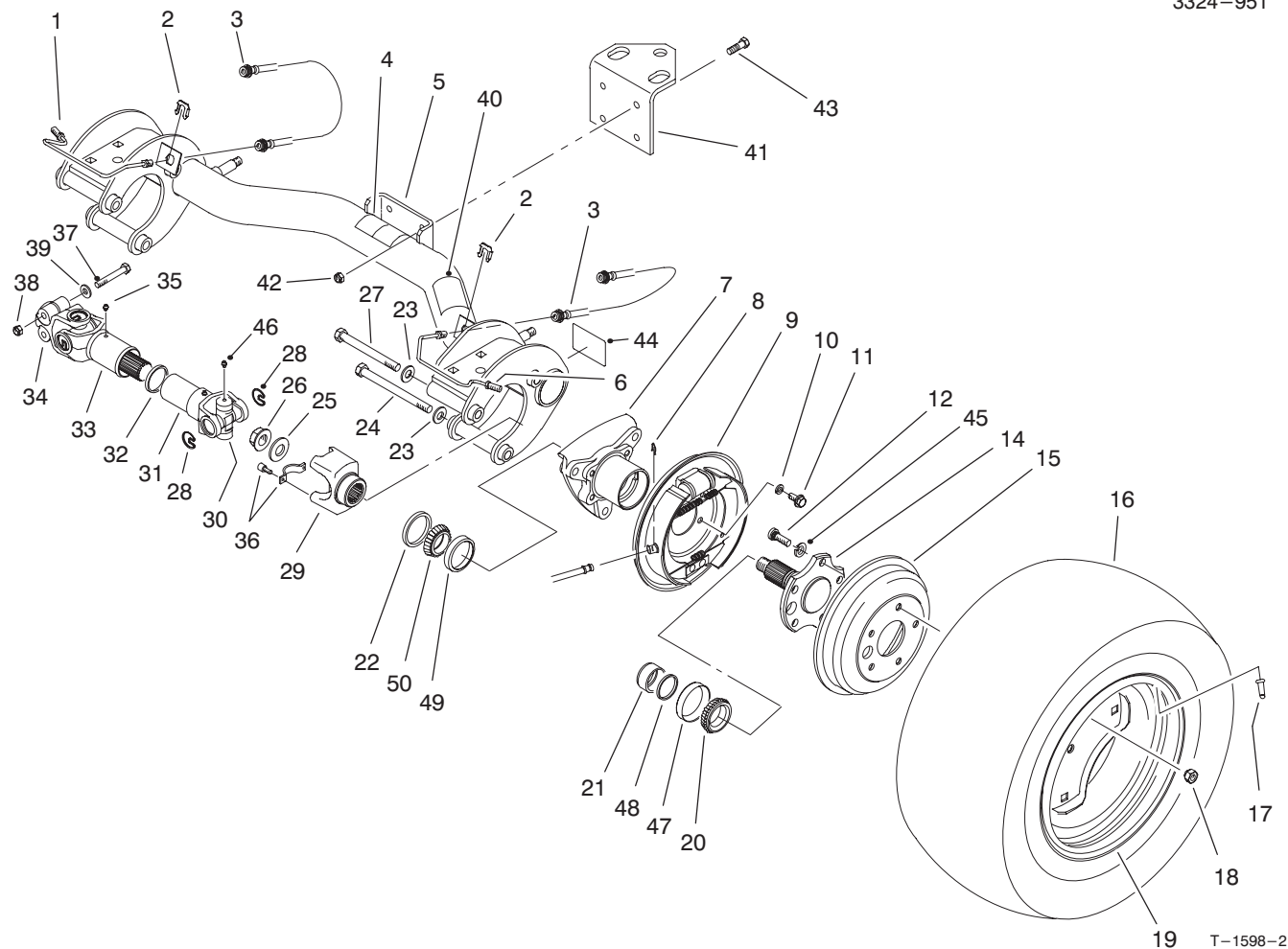

REAR AXLE ASSEMBLY (Continued)

Ref. No.	Part No.	Description	No. Used	Ref. No.	Part No.	Description	No. Used
†48		Spacer	1	*	87-1970	Bearing – Matched Set Use 1 set per wheel	
†49		Cup – Bearing	1			(Incl. Ref. #20 & 47-50)	2
†50		Cone – Bearing	1	*	98-2969	1/2 Yoke Kit	2
*51	98-2918	Driveshaft Assembly (Incl. Ref. #28, 30-35 & 46)	2	*	98-2967	Driveshaft Assembly Kit (Incl. Ref. #29 & 36)	2
*	87-6370	Rear Tire & Wheel Assembly (23")	2	*	98-2968	Yoke Kit (Incl. Ref. #34 & 37)	2
*	87-5370	Rear Tire & Wheel Assembly (24")	2				

*Not Illustrated

†Not Serviced Separately

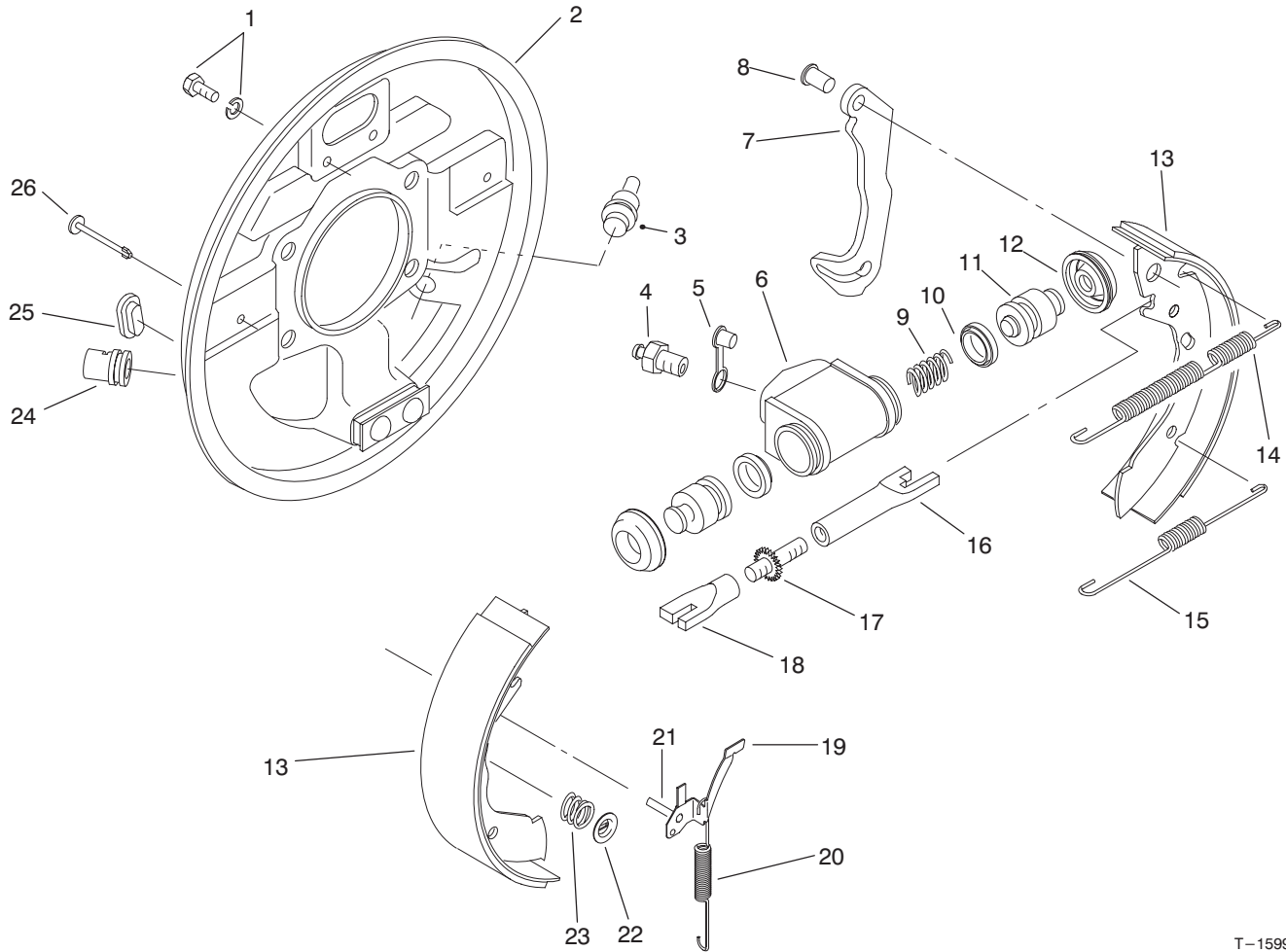

T-1599-1

REAR BRAKE ASSEMBLY

Ref. No.	Part No.	Description	No. Used	Ref. No.	Part No.	Description	No. Used
1	92-4135	Set Bolt	2	19	92-4123	Pawl Assembly - LH (Incl. Ref. #21)	1
2	92-4138	Backplate Assembly LH (Incl. Ref. #24)	1	*	92-4124	Pawl Assembly - RH (Incl. Ref. #21)	1
*	92-4139	Backplate Assembly RH (Incl. Ref. #24)	1	20	92-4150	Spring - Adjuster, LH	1
3	92-4146	Plug	1	*	92-4151	Spring - Adjuster, RH	1
4	92-4137	Screw - Bleed	1	21		Pin - Pawl	1
5	92-4114	Cap - Bleed Screw	1	22	92-4131	Washer - Hold Down	2
6		Body	1	23	92-4152	Spring - Hold Down	2
7		Lever - Operating LH/RH	1	24		Guide - Pipe	1
8		Pin	1	25	92-4134	Plug - Inspection	1
9		Spring	1	26	92-4133	Pin - Hold Down	2
10		Seal - 'L' Type	2	*	92-4144	Adjuster Assembly - LH (Incl. Ref. #16-18)	1
11		Piston	2	*	92-4145	Adjuster Assembly - RH (Incl. Ref. #16-18)	1
12		Cover - Dust	2	*	92-4140	Wheel Cylinder Assy. - LH (Incl. Ref. #4-6 & 9-12)	1
13	92-4143	Shoe & Lining Set (4 Shoes) (Incl. Ref. #7 & 8)	1	*	92-4141	Wheel Cylinder Assy. - RH (Incl. Ref. #4-6 & 9-12)	1
14	92-4147	Spring - Shoe, Upper LH	1	*	92-4142	Seal Kit (Incl. Ref. #10 & 12)	1
*	92-4148	Spring - Shoe, Upper RH	1	*	93-7125	Rear Brake Assembly - RH (Complete)	1
15	92-4149	Spring - Shoe, Lower	1	*	93-7126	Rear Brake Assembly - LH (Complete)	1
16		Pushrod - Female LH	1				
*		Pushrod - Female RH	1				
17		Bolt - Adjuster	1				
18		Sleeve - Adjuster	1				

*Not Illustrated

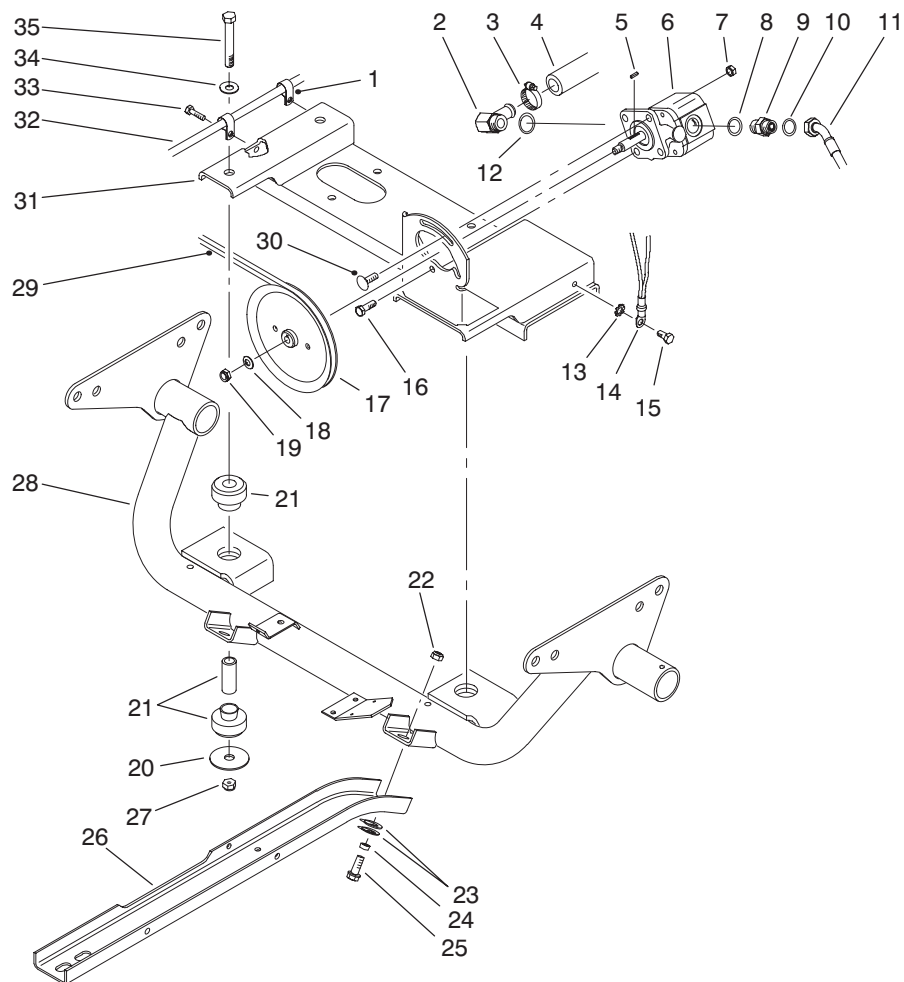

T-1735-1

ENGINE FRAME & HYDRAULIC PUMP DRIVE ASSEMBLY

Ref. No.	Part No.	Description	No. Used	Ref. No.	Part No.	Description	No. Used
1	2412-89	Clamp - R	2	17	87-7740	Pulley	1
2	87-8170	Fitting - Hydraulic 90° (Incl. Ref. #12)	1	18	3256-45	Washer - Flat	1
3	2412-34	Clamp - Hose	1	19	3296-5	Nut - Lock	1
4	87-8030	Hose - Hydraulic	1	20	87-5100	Washer - Snubbing	2
5	92-2179	Key - Square	1	21	87-4970	Engine Mount Assembly	2
6	87-5700	Hydraulic Pump Assembly (Incl. Ref. #5)	1	22	3296-39	Nut - Lock	6
7	3296-29	Nut - Lock	2	23	3290-413	Washer - Belleville	12
8	237-79	Seal - O-Ring	1	24	76-9100	Spacer	6
9	340-3	Fitting - Hydraulic Straight (Incl. Ref. #8 & 10)	1	25	3234-11	Screw - Cap Hex. Hd.	6
10	237-22	Seal - O-Ring	1	26	87-4730-03	Guard - Belly	2
11	87-8020	Hose - Hydraulic	1	27	3296-48	Nut - Lock	2
12	237-80	Seal - O-Ring	1	28	93-7095	Support - Engine	1
13	3255-8	Washer - Lock ETLW	1	29	87-8370	Belt - V	1
14	87-3080	Cable - Battery Negative	1	30	3230-22	Bolt - Carriage	1
15	32144-14	Screw - Self Tapping	1	31	87-6400-03	Frame - Engine	1
16	322-5	Screw - Cap Hex. Hd.	1	32	87-8240	Cable - Parking Brake	2
				33	32144-10	Screw - Self Tapping	2
				34	3256-25	Washer - Flat	2
				35	324-12	Screw - Cap Hex. Hd.	2

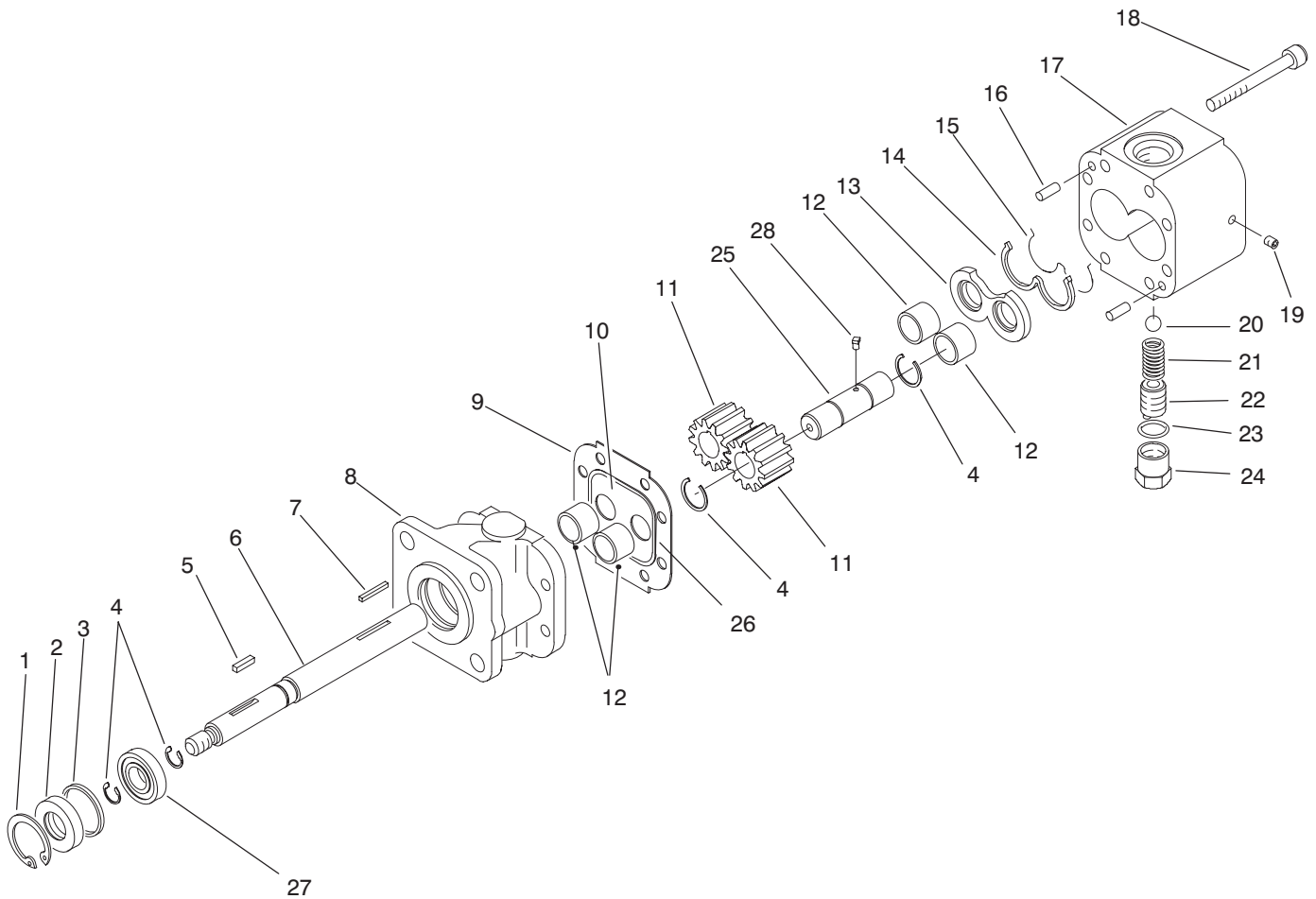

T-1601-1

HYDRAULIC PUMP ASSEMBLY NO. 87-5700

Ref. No.	Part No.	Description	No. Used
1	32151-41	Ring - Retaining	1
2	92-2195	Seal - Oil	1
3	92-2186	Spacer	1
4	92-2178	Ring - Crescent	4
5	92-2179	Key - Square	1
6	92-2189	Shaft - Drive	1
7	92-2177	Pin - Shear	1
†8		Stator	1
9	92-2182	Plate - Seal	1
10	92-2183	Plate - Wear	1
11	92-2175	Gear	2
12	92-2192	Bearing	4
13	92-2181	Plate - Pressure	1
14	92-2197	Seal - Back Up	1

Ref. No.	Part No.	Description	No. Used
15	92-2196	Seal - Pressure Plate	1
16	92-2176	Pin - Dowel	2
17	92-2187	Housing - Gear, End	1
18	92-2173	Screw - Cap Socket Head	8
19	92-2185	Plug	1
20	92-2193	Ball	1
21	92-2194	Spring	1
22	92-2174	Screw - Adjusting	1
23	92-2180	Gasket - Copper	1
24	92-2184	Cap - Relief Valve	1
25	92-2190	Shaft - Idler	1
26	92-2198	Seal	1
27	92-2191	Bearing	1
28	92-2199	Key - Ball	1

† Not Serviced Separately.

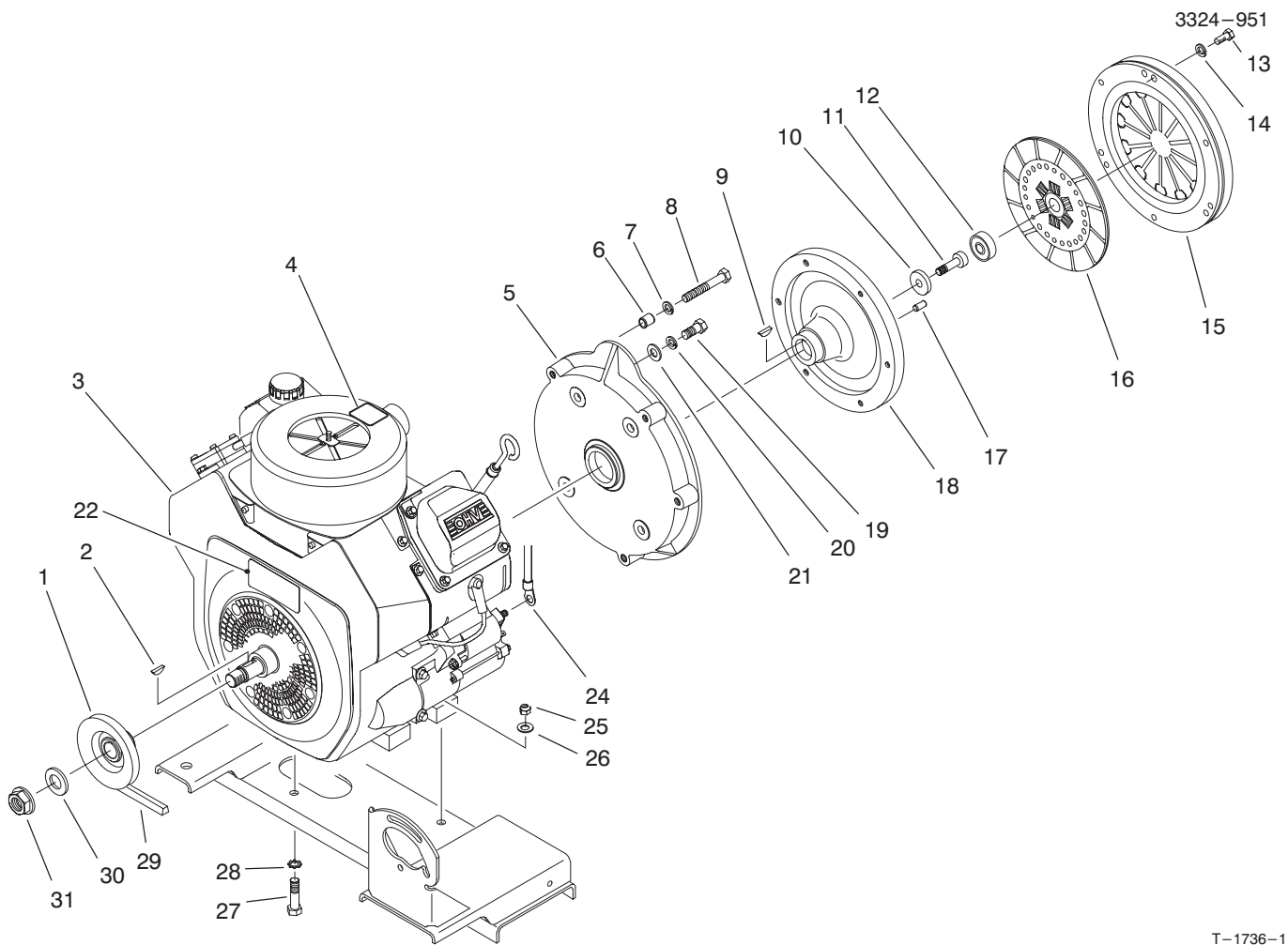

T-1736-1

ENGINE INSTALLATION ASSEMBLY

Ref. No.	Part No.	Description	No. Used	Ref. No.	Part No.	Description	No. Used
1	87-7710-03	Pulley	1	16	98-2959	Disk - Clutch	1
2	3257-7	Key - Woodruff	1	17	42-7160	Pin - Dowel	3
3	87-7900	Engine Assembly	1	18	87-6480	Flywheel	1
4	87-8770	Decal - Air Cleaner	1	19	324-4	Screw - Cap Hex. Hd.	4
5	87-6390-01	Adapter - Clutch	1	20	3253-6	Washer - Lock	4
6	92-2152	Bushing - Dowel	2	21	3256-25	Washer - Flat	4
7	3253-22	Washer - Lock	4	22	80-8040	Decal - Warning	1
8	56-2150	Screw - Cap Hex. Hd.	4	24	87-8000	Cable - Battery Positive	1
9	3257-5	Key - Woodruff	1	25	3296-39	Nut - Lock	4
10	87-6080	Washer	1	26	3256-24	Washer - Flat	4
11	3274-1	Screw - Hex. Socket Hd.	1	27	323-9	Screw - Cap Hex. Hd.	4
12	87-6460	Bearing - Pilot	1	28	3255-9	Washer - Lock	1
13	33114-016	Screw - Cap Hex. Hd.	6	29	87-8370	Belt - V	1
14	3253-4	Washer - Lock	6	30	3256-28	Washer - Flat	1
15	98-2958	Cover - Clutch	1	31	3296-15	Nut - Lock	1

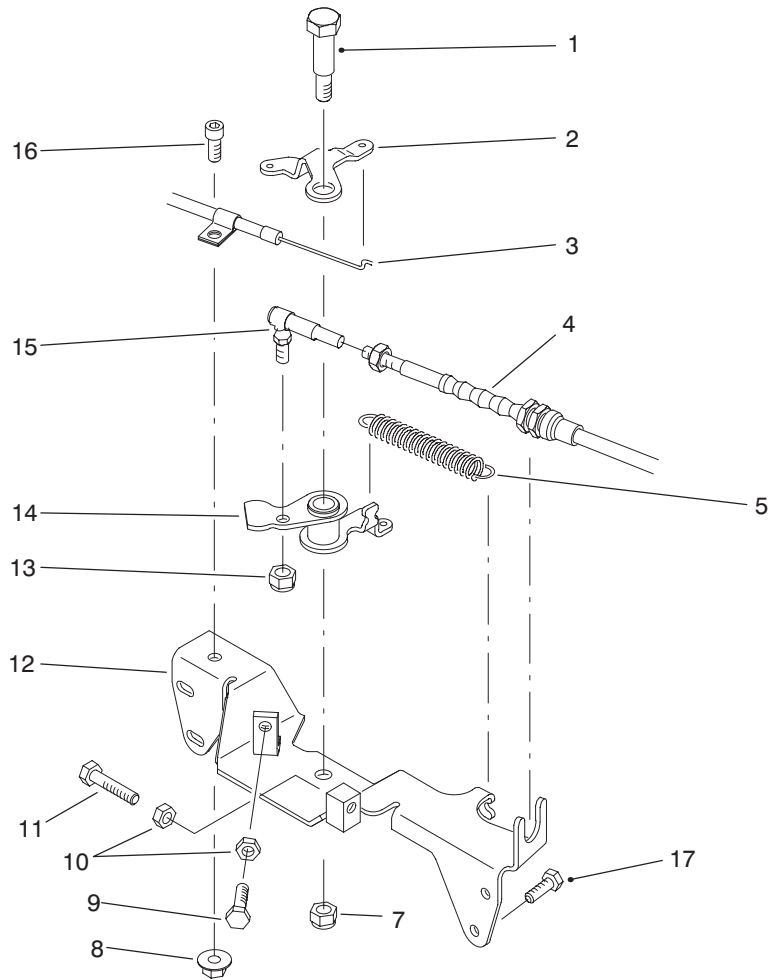

T-1802-2

THROTTLE LINKAGE ASSEMBLY

Ref. No.	Part No.	Description	No. Used	Ref. No.	Part No.	Description	No. Used
1	7-0030	Bolt - Shoulder	1	10	3220-1	Nut - Jam	2
2	87-7790	Lever - Choke	1	11	329-7	Screw - Cap Hex. Hd.	1
3	87-8060	Cable - Choke	1	12	87-7780-03	Bracket - Throttle	1
4	94-3834	Cable - Accelerator	1	13	3296-3	Nut - Lock	1
5	67-1450	Spring - Extension	1	14	87-7800	Lever - Throttle	1
7	3296-29	Nut - Lock	1	15	18-1720	Joint - Ball	1
8	32128-33	Nut - Flange Lock	1	16	3274-15	Screw - Hex. Socket Hd.	1
9	329-6	Screw - Cap Hex. Hd.	1	17	32144-4	Screw - HH	2

PROTOTYPE

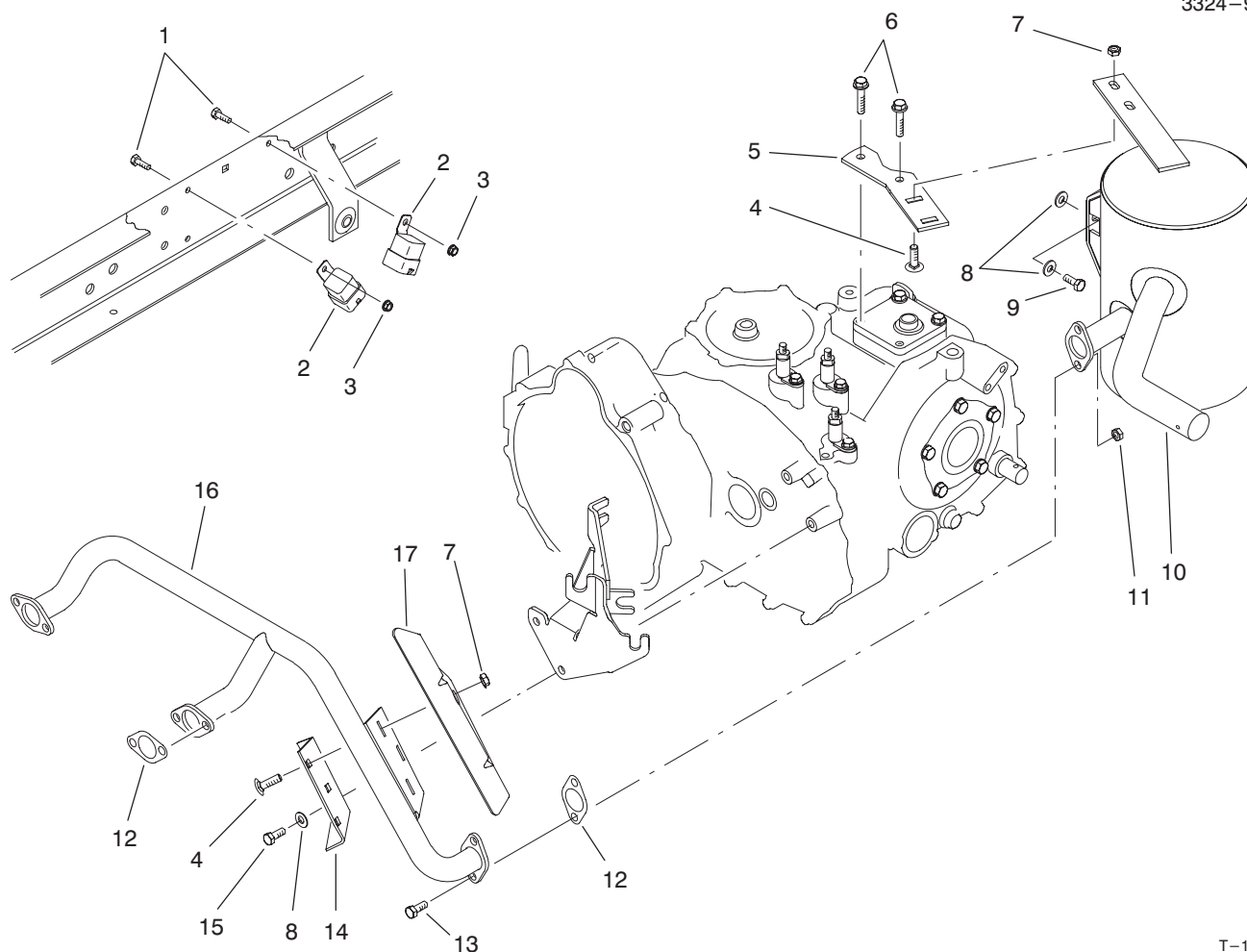

T-1807-1

MUFFLER & RELAY ASSEMBLY

Ref. No.	Part No.	Description	No. Used	Ref. No.	Part No.	Description	No. Used
1	321-4	Screw - Cap Hex. Hd.	2	10	87-7840	Muffler - Exhaust	1
2	70-1480	Relay	2	11	32128-25	Nut - Lock	2
3	32128-33	Nut - Flange Lock	2	12	87-8650	Gasket - Muffler	3
4	3230-2	Bolt - Carriage	5	13	322-4	Screw - Cap Hex. Hd.	2
5	87-8680	Plate - Muffler Mount	1	14	87-7980	Bracket - Muffler	1
6	33114-030	Screw - Cap Hex. Hd.	2	15	33114-025	Screw - Cap Hex. Hd.	2
7	32128-20	Nut - Flange Lock	5	16	87-7850	Manifold - Exhaust	1
8	87-8640	Washer - Flat	4	17	87-7860	Shield - Heat	1
9	33114-020	Screw - Cap Hex. Hd.	1				

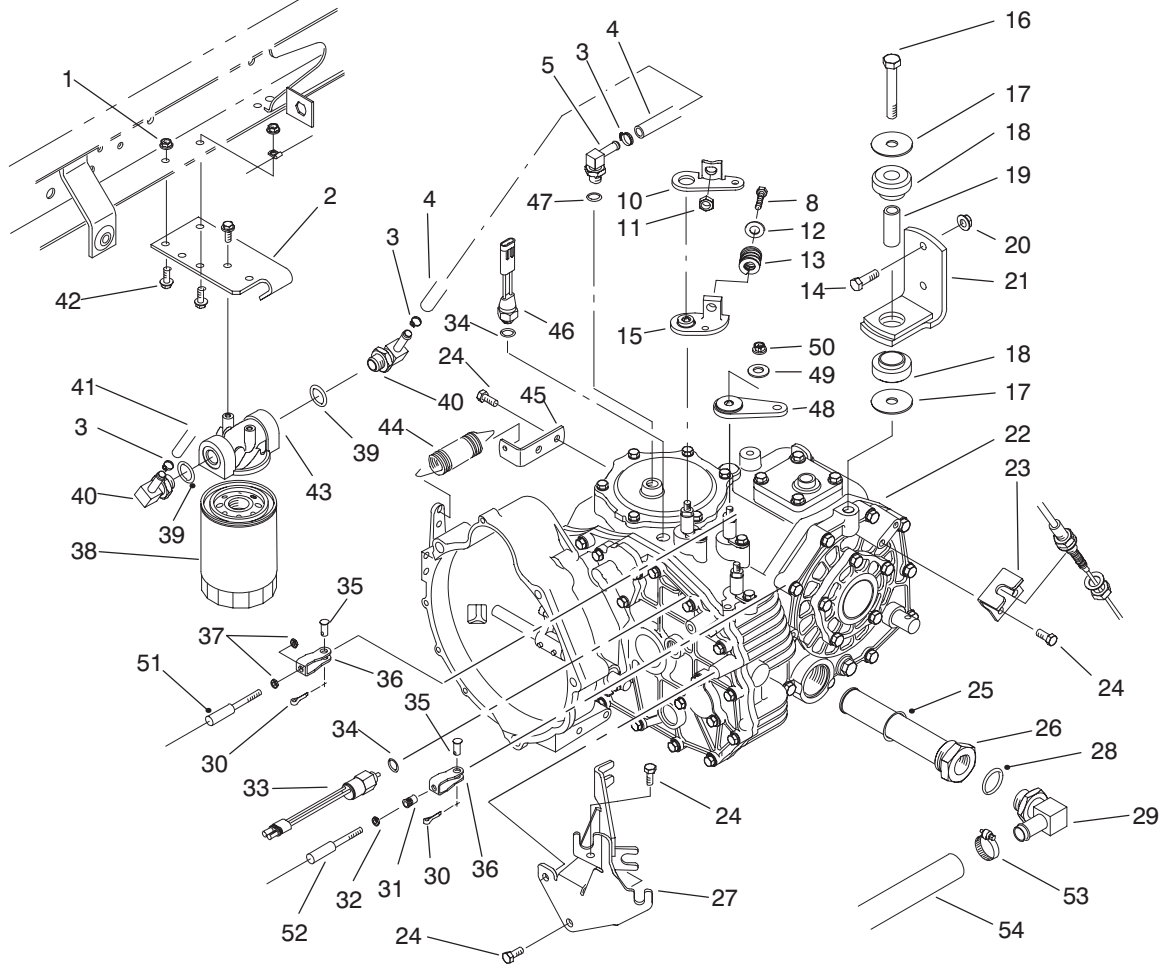

T-1607-1

TRANSAXLE INSTALLATION ASSEMBLY

Ref. No.	Part No.	Description	No. Used	Ref. No.	Part No.	Description	No. Used
1	32128-33	Nut - Flange Lock	1	27	87-4820-03	Bracket - Cable	1
2	87-7040-03	Bracket - Oil Filter	1	28	237-81	Seal - O-Ring	1
3	2412-36	Clamp - Hose	3	29	353-987	Fitting - Hydraulic 90° (Incl. Ref. #28)	1
4	87-5730	Hose - Hydraulic	1	30	3272-6	Pin - Cotter	3
5	354-135	Fitting - Hydraulic 90° (Incl. Ref. #47)	1	31	32148-15	Nut - Clinch	1
8	323-10	Screw - Cap Hex. Hd.	1	32	3219-14	Nut - Hex.	1
10	87-8250	Plate - Shift Arm	1	33	87-6710	Switch - Supervisor	1
11	32128-21	Nut - Lock	1	34	237-30	O-Ring	2
12	3256-4	Washer - Flat	1	35	283-62	Pin - Clevis	3
13	87-6910	Spring - Compression	1	36	87-2310	Clevis - Cable	3
14	323-7	Screw - Cap Hex. Hd.	4	37	3220-1	Nut - Jam	4
15	87-7970	Arm - Shift	1	38	54-0110	Element - Oil Filter	1
16	3215-1	Screw - Cap Hex. Hd.	2	39	237-79	Seal - O-Ring	2
17	87-5100	Washer	4	40	354-134	Fitting - Hydraulic 90° (Incl. Ref. #39)	2
18	87-4970	Transaxle Mount Assembly (Incl. Ref. #19)	4	41	87-4920	Hose - Hydraulic	1
19		Spacer - Mount	2	42	3234-4	Screw - Hex. Flange Hd.	4
20	3296-39	Nut - Flange Lock	4	43	87-8780	Head - Oil Filter	1
21	87-5800-03	Bracket - Mount	2	44	68-9950	Spring - Extension	1
22	100-4463	Transaxle Assembly	1	45	87-7170	Bracket - Clutch Spring	1
23	87-4470	Bracket	1	46	72-4310	Switch - Ball N.C.	1
24	33114-020	Screw - Cap Hex. Hd.	5	47	237-42	Seal - O-Ring	1
25	237-123	Seal - O-Ring	1	48	87-7960	Clamp - Shift Arm	2
26	87-3990	Oil Strainer Assembly (Incl. Ref. #25)	1	49	80-6990	Washer - Flat	3
				50	48-9520	Nut - Lock	3

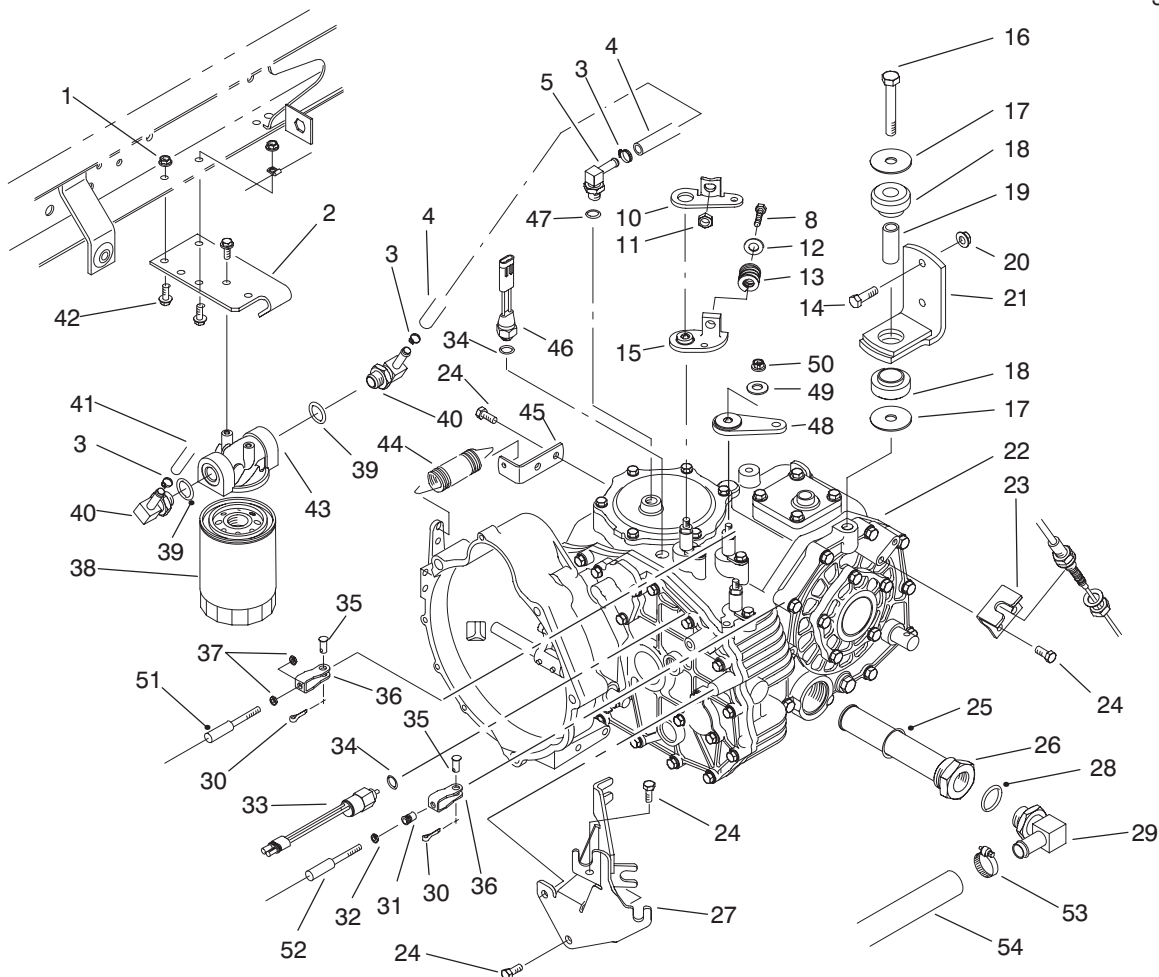

T-1607-1

TRANSAXLE INSTALLATION ASSEMBLY (Continued)

Ref. No.	Part No.	Description	No. Used	Ref. No.	Part No.	Description	No. Used
51	87-4260	Shift Cable Assembly (Incl. Ref. #37)	2	53	2412-34	Clamp - Hose	1
52	87-4420	Hi-Lo Cable Assembly (Incl. Ref. #32)	1	54	87-8030	Hose - Hydraulic	1

PROTOTYPE

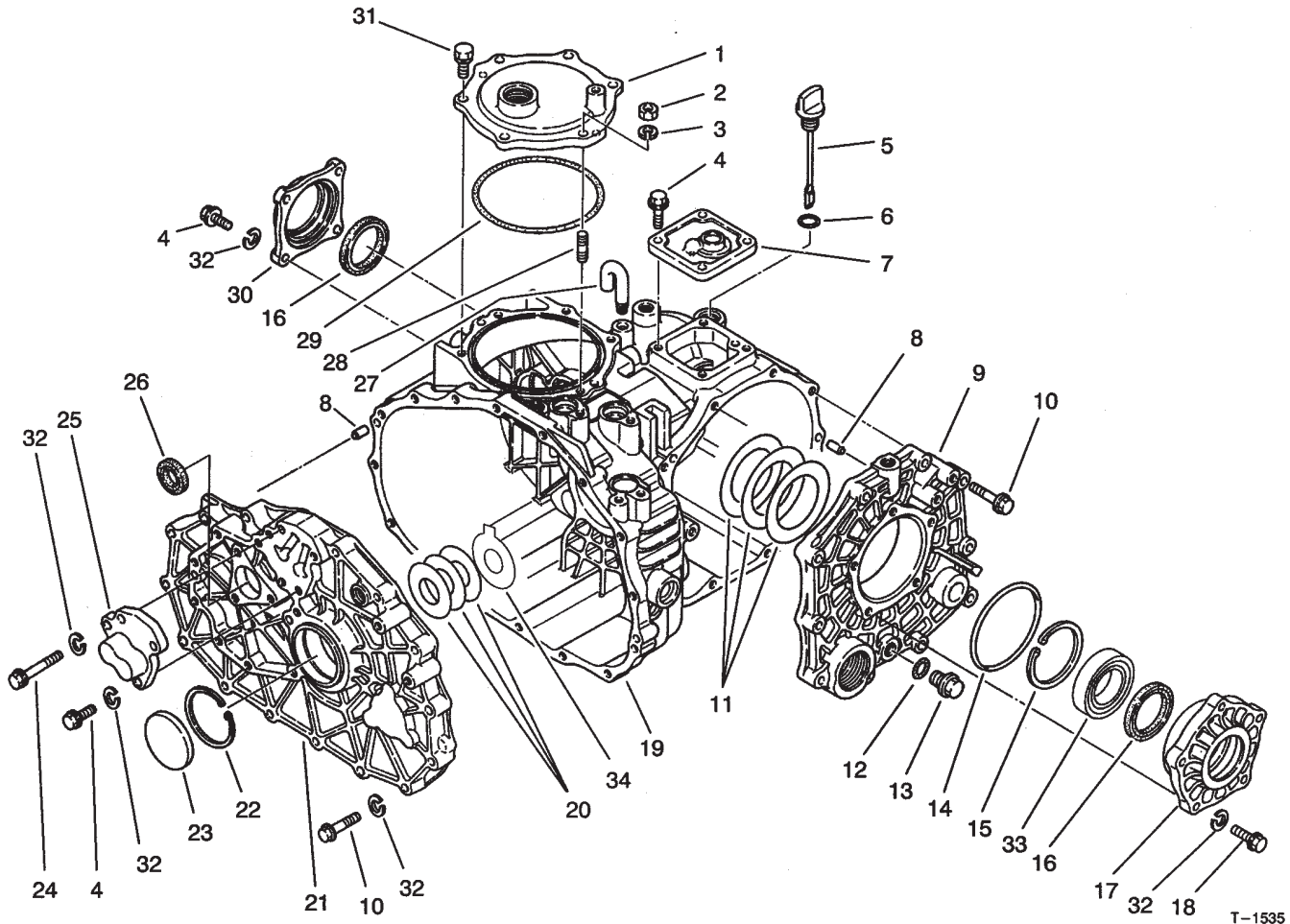

T-1535

TRANSAXLE CASE ASSEMBLY

Ref. No.	Part No.	Description	No. Used
1	92-0656	Cover - P.T.O.	1
2	48-7930	Nut - Hex.	1
3	92-0762	Washer - Lock	1
4	60-6750	Screw - Cap Hex. Hd.	11
5	92-0662	Cap - Oil	1
6	92-0788	O-Ring	1
7	92-0652	Cover - Upper	1
8	92-0765	Pin - Alignment	4
9	92-0653	Cover - Side	1
10	42-9530	Screw - Cap Hex. Hd.	25
11	92-0809	Shim Set	1
12		O-Ring	1
13	92-0773	Drain Plug Assembly (Incl. Ref. #12)	1
14	92-0789	O-Ring	1
15	92-0760	Ring - Retaining	1
16	92-0793	Seal - Oil	2
17	92-0654	Carrier - Differential	1

Ref. No.	Part No.	Description	No. Used
18	48-7730	Screw - Cap Hex. Hd.	5
19	92-0651	Case - Transaxle	1
20	100-4460	Shim Set	1
21	100-4461	Plate - Center	1
22	92-0759	Ring - Retaining	1
23	92-0807	Cap - Sealing	1
24	48-7560	Screw - Cap Hex. Hd.	1
25	92-0706	Cap - Fork Shaft	1
26	92-0791	Seal - Oil	1
27	92-0743	Breather - Air	1
28	92-0804	Stud	4
29	92-0790	O-Ring	1
30	92-0655	Cover - Seal	1
31	92-0796	Screw - Cap Hex. Hd.	5
32	42-9850	Washer - Lock	42
33	92-0775	Bearing - Ball	2
34	100-4165	Shim-w/Tab	1

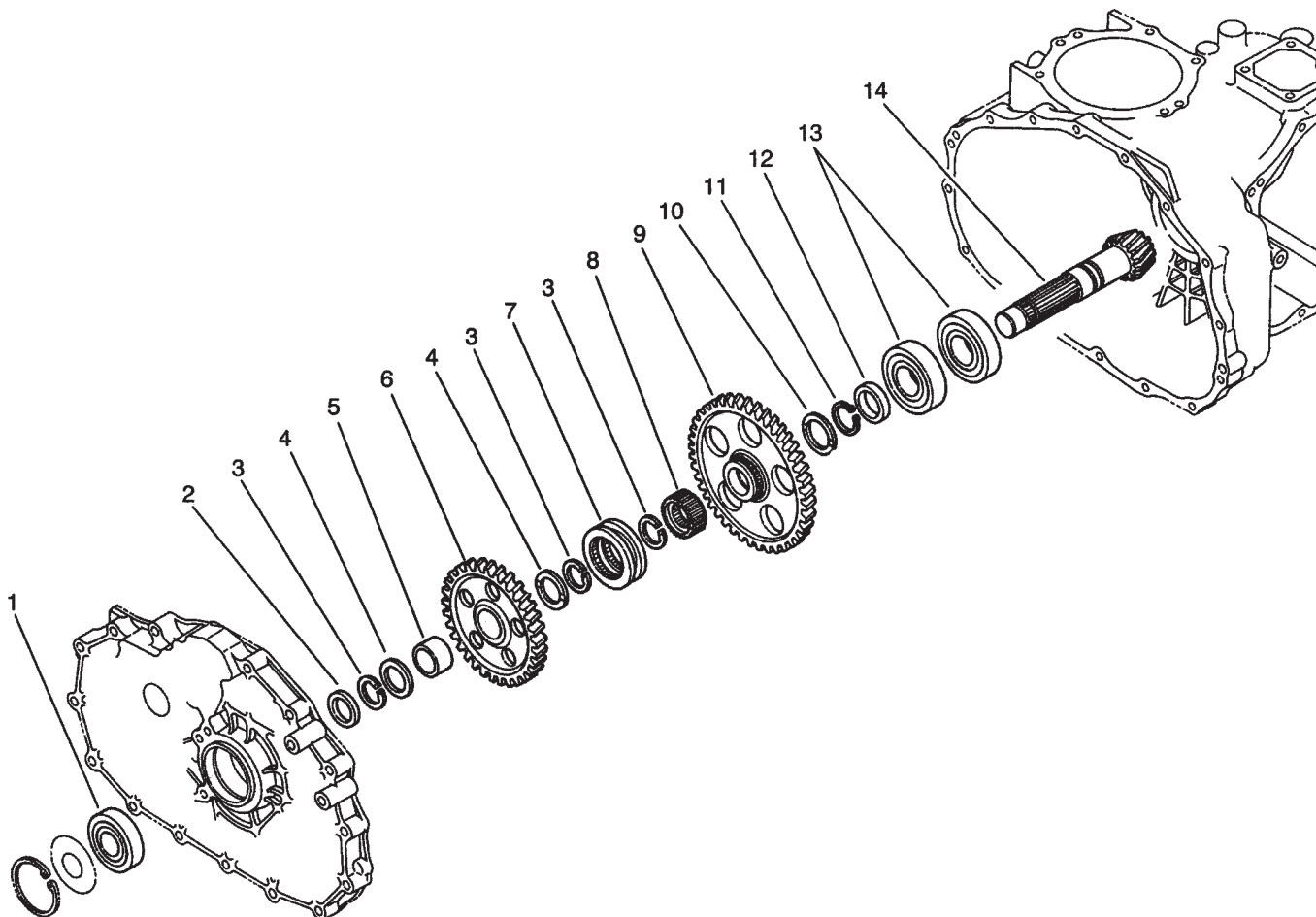

T-1536-1

COUNTERSHAFT ASSEMBLY

Ref. No.	Part No.	Description	No. Used	Ref. No.	Part No.	Description	No. Used
1	92-0712	Bearing - Ball	1	9	92-0717	Gear - 71T	1
2	92-0716	Collar	1	10	92-0741	Washer - Thrust	1
3	92-0764	Ring - Retaining	3	11	92-0755	Ring - Retaining	1
4	92-0711	Washer - Thrust	2	12	92-0713	Collar	1
5	92-0783	Sleeve - Inner	1	13	92-0714	Bearing - Ball	2
6	92-0715	Gear - 49T	1	14	92-0710	Counter Shaft Assembly (Incl. Ring Gear)	1
7	92-0718	Shifter - Hi-Lo	1				
8	92-0719	Collar - Spline	1				

PROTOTYPE

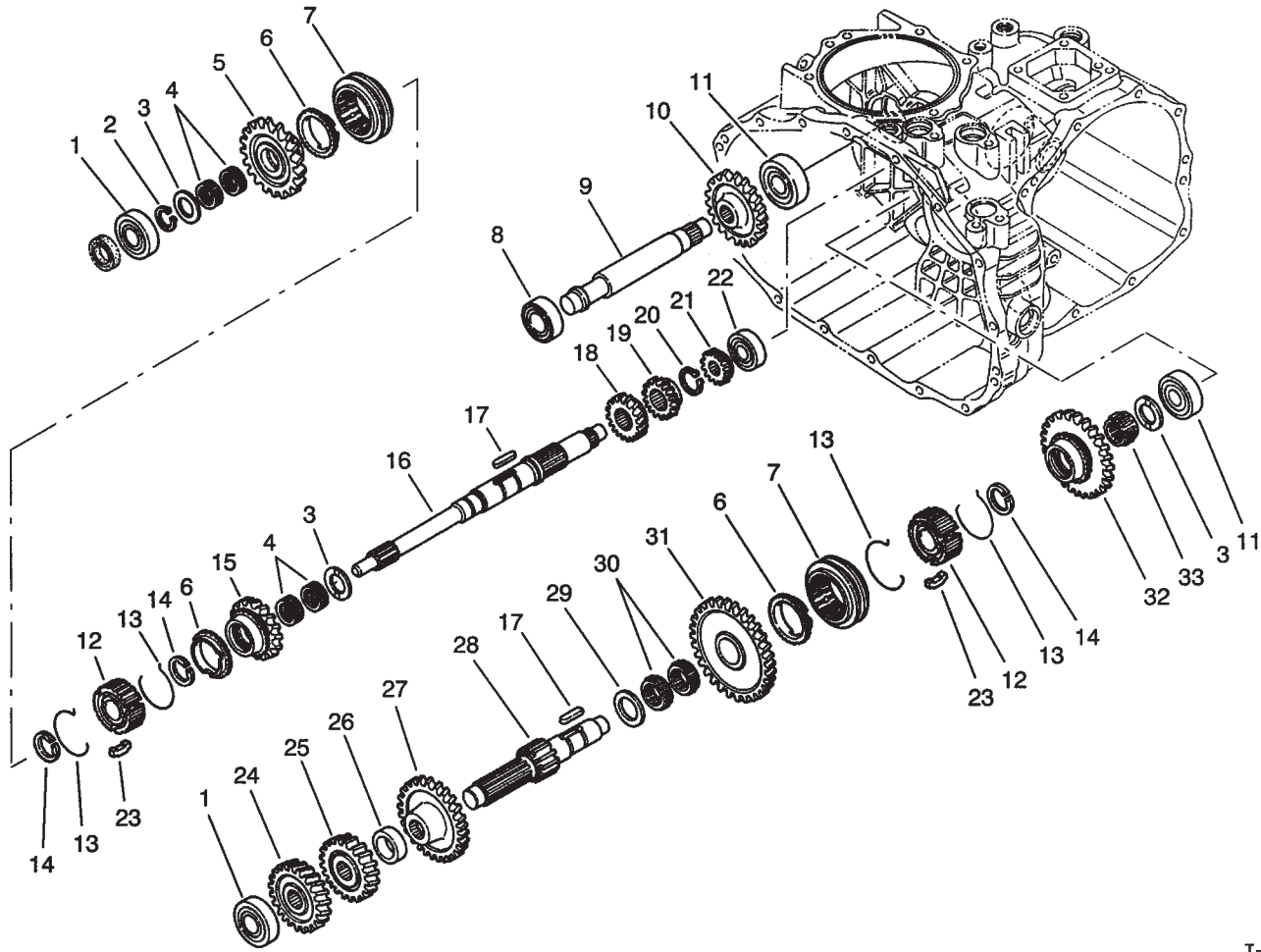

T-1533

TRANSAXLE GEAR SHAFTS ASSEMBLY

Ref. No.	Part No.	Description	No. Used
1	251-8	Bearing - Ball	2
2	92-0753	Ring - Retaining	1
3	92-0740	Washer - Thrust	3
4	92-0781	Bearing - Needle	4
5	92-0820	Gear - 27T	1
6	92-0667	Ring - Synchro	3
7	92-0668	Shifter - Synchro	2
8	251-346	Bearing - Ball	1
9	92-0824	Shaft - Reverse Idler	1
10	92-0684	Gear - 33T	1
11	92-0778	Bearing - Ball	2
12	92-0664	Hub - Synchro	2
13	92-0666	Spring - Synchro	4
14	92-0763	Ring - Retaining	3
15	92-0821	Gear - 24T	1
16	92-0663	Shaft - Main	1
17	92-0772	Key	2

Ref. No.	Part No.	Description	No. Used
18	92-0687	Gear - 16T	1
19	92-0672	Gear - 18T	1
20	92-0754	Ring - Retaining	1
21	92-0673	Gear - 14T	1
22	92-0650	Bearing - Ball	1
23	92-0665	Key - Synchro	6
24	92-0822	Gear - 28T	1
25	92-0679	Gear - 23T	1
26	92-0680	Collar	1
27	92-0823	Gear - 43T	1
28	92-0674	Shaft - Reduction	1
29	92-0682	Washer - Thrust	1
30	92-0681	Bearing - Needle	2
31	92-0677	Gear - 49T	1
32	92-0819	Gear - 40T	1
33	92-0782	Bearing - Needle	1

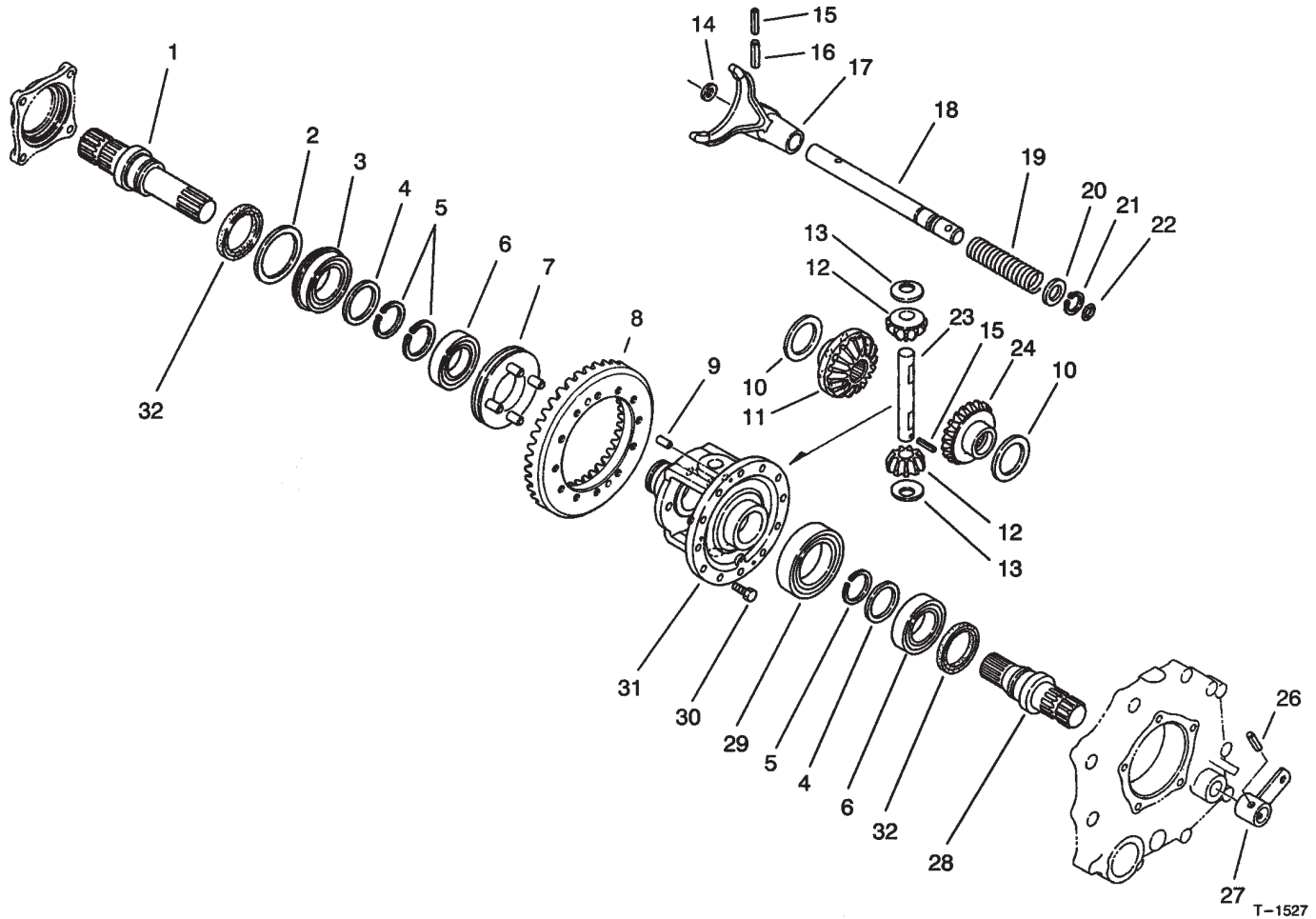

DIFFERENTIAL GEAR ASSEMBLY

Ref. No.	Part No.	Description	No. Used
1	92-0726	Shaft - Axle R.H.	1
2	92-0728	Washer	1
3	92-0780	Bearing - Ball	1
4	92-0727	Washer	2
5	92-0756	Ring - Retaining	3
6	92-0775	Bearing - Ball	2
7	92-0730	Slider - Differential Lock	1
8	92-0710	Ring Gear Assembly (Incl. Counter Shaft)	1
9	92-0765	Pin - Alignment	2
10	92-0747	Washer - Thrust	2
11	92-0746	Gear - Side R.H.	1
12	92-0748	Gear - Pinion	2
13	92-0750	Washer	2
14	92-0744	Washer	1
15	92-0768	Pin - Spring	2

Ref. No.	Part No.	Description	No. Used
16	92-0771	Pin - Spring	1
17	92-0721	Fork - Differential Lock	1
18	92-0722	Shaft - Lock Fork	1
19	92-0723	Spring - Compression	1
20	92-0733	Washer	1
21	92-0753	Ring - Retaining	1
22	92-0787	O-Ring	1
23	92-0749	Shaft - Pinion	1
24	92-0745	Gear - Side L.H.	1
26	92-0770	Pin - Spring	1
27	92-0724	Arm - Differential Lock	1
28	92-0725	Shaft - Axle L.H.	1
29	92-0776	Bearing - Ball	1
30	92-0803	Screw - Hex. Flange Hd.	12
31	92-0720	Case - Differential	1
32	92-0793	Seal - Oil	2

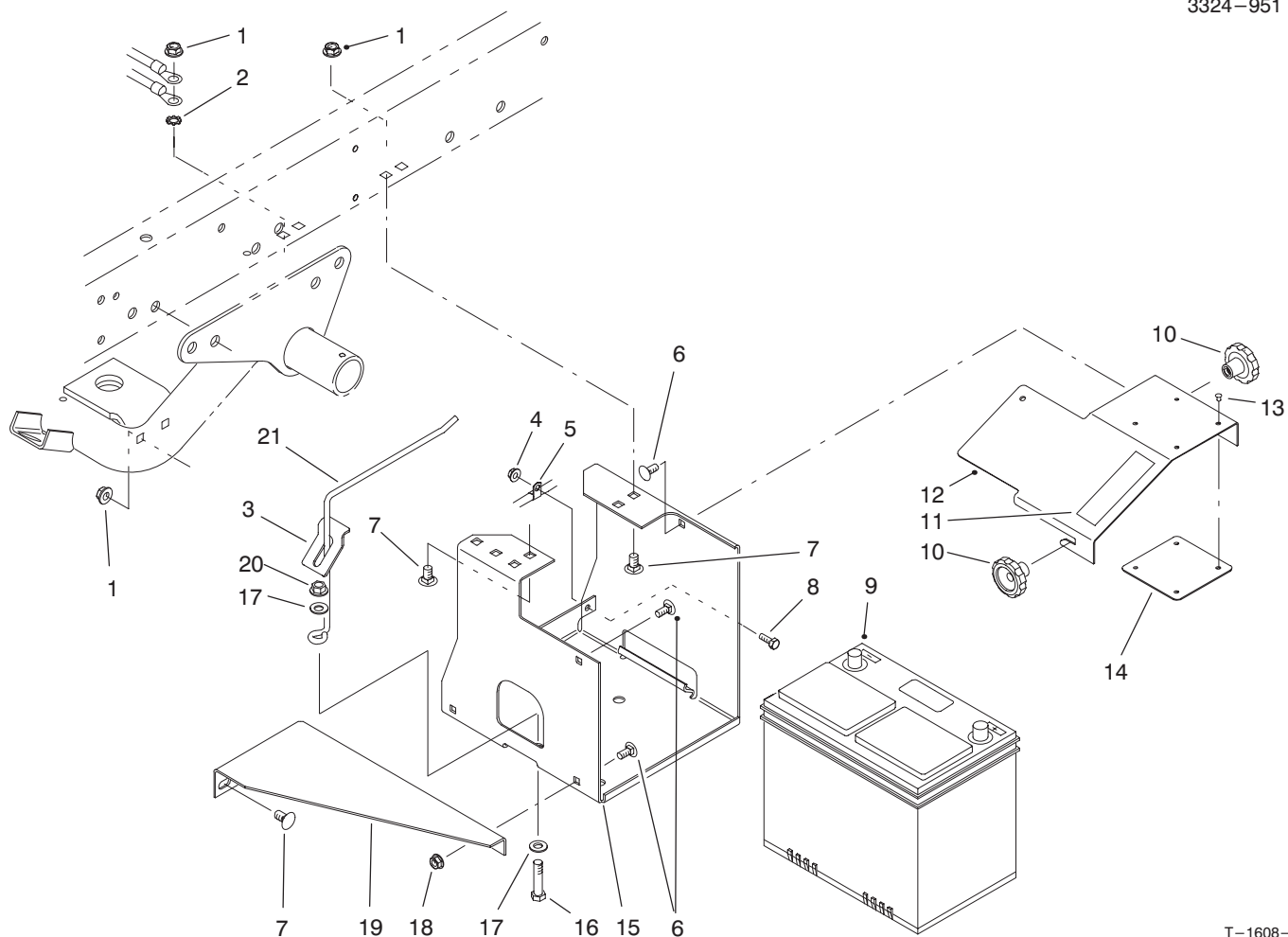

T-1608-2

BATTERY MOUNT ASSEMBLY

Ref. No.	Part No.	Description	No. Used	Ref. No.	Part No.	Description	No. Used
1	3290-357	Nut - Flange Lock	6	12	87-5130-03	Cover - Battery Base	1
2	3255-9	Washer - Lock ETLW	1	13	3269-27	Rivet - Plastic	4
3	87-7610	Tab - Battery Support	1	14	87-7620	Shield - Plastic	1
4	32128-33	Nut - Flange Lock	1	15	87-5120-03	Bracket - Battery Base	1
5	2412-89	Clamp - R	1	16	323-9	Screw - Cap Hex. Hd.	1
6	3230-23	Bolt - Carriage	4	17	3256-24	Washer - Flat	2
7	3231-21	Bolt - Carriage	6	18	32128-20	Nut - Flange Lock	2
8	321-4	Screw - Cap Hex. Hd.	1	19	87-5110-03	Support - Lower	1
9	55-7290	Battery	1	20	3296-39	Nut - Flange Lock	1
10	19-4050	Knob	2	21	87-7600	Rod - Battery Support	1
11	36-3400	Decal - No Step	1				

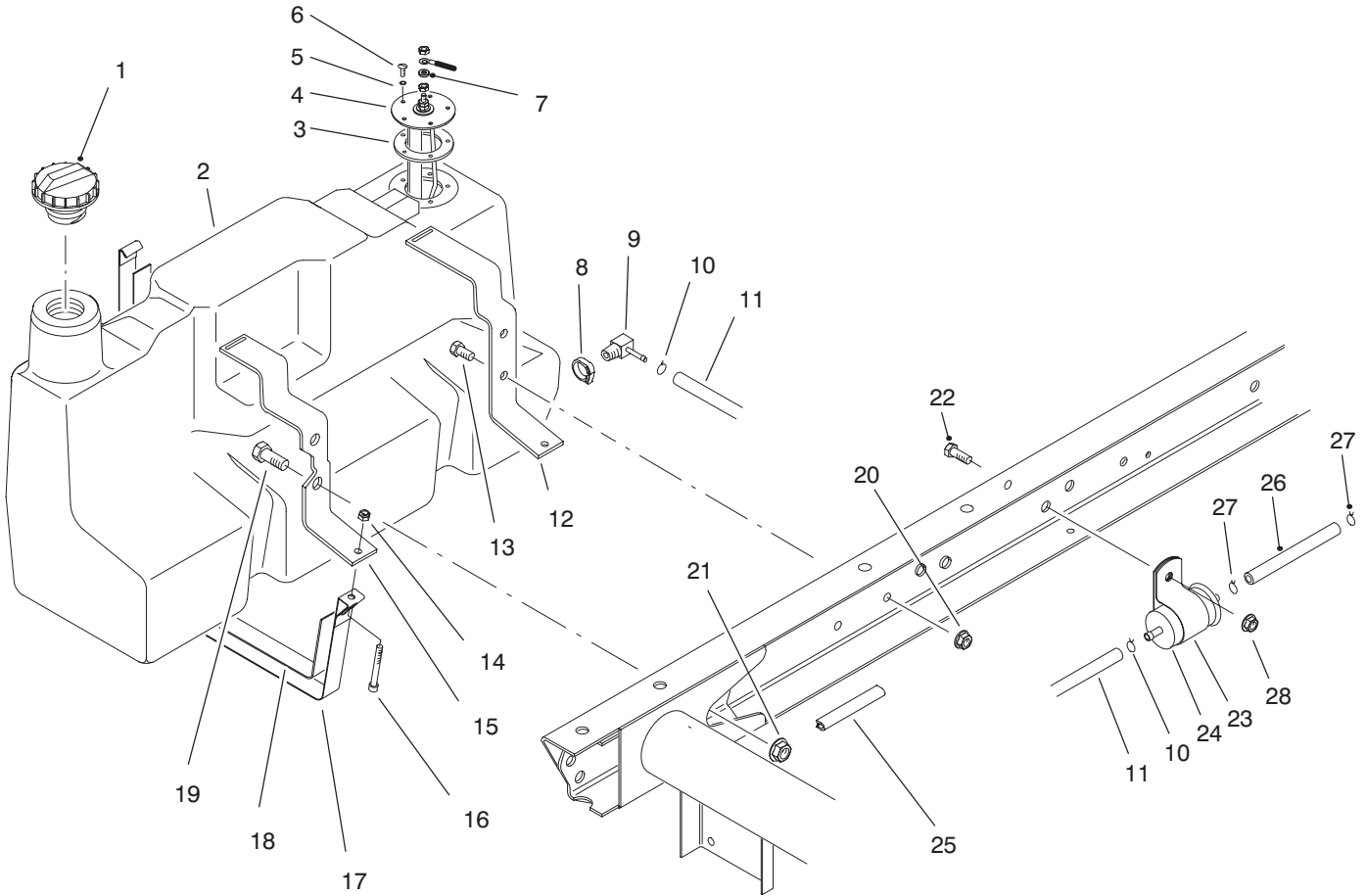

T-1737

FUEL TANK ASSEMBLY

Ref. No.	Part No.	Description	No. Used
1	93-3101	Cap - Fuel	1
2	98-2919	Fuel Tank Assembly (Incl. Ref. #8 & 9)	1
3	62-7650	Gasket - Sending Unit	1
4	63-7640	Unit - Sending	1
5	3253-15	Washer - Lock	5
6	32122-24	Screw - Round Hd.	5
7	5-3637	Washer - Flat	1
8	2412-36	Clamp	1
9	76-4430	Fitting - Fuel 90°	1
10	2412-108	Clamp - Hose	2
11	63-9640	Hose - Fuel	1
12	87-3140-03	Support - Rear	1
13	323-4	Screw - Cap Hex. Hd.	2
14	3296-42	Nut - Lock	2

Ref. No.	Part No.	Description	No. Used
15	87-3150-03	Support - Front	1
16	3274-54	Screw - Hex. Socket Hd.	2
17	87-3160	Strap - Tank Support	2
18	87-3170	Pad - Tank Support Strap	2
19	3234-38	Screw - Cap Hex. Hd.	2
20	3290-357	Nut - Flange	2
21	32128-23	Nut - Flange	2
22	3234-4	Screw - HFH	1
23	2412-148	Clamp - R	1
24	99-9404	Filter - Fuel	1
25	43-4300	Trim	1
26	66-1600	Hose - Fuel	1
27	2412-98	Clamp	2
28	32128-33	Nut - Hex. Flange	1

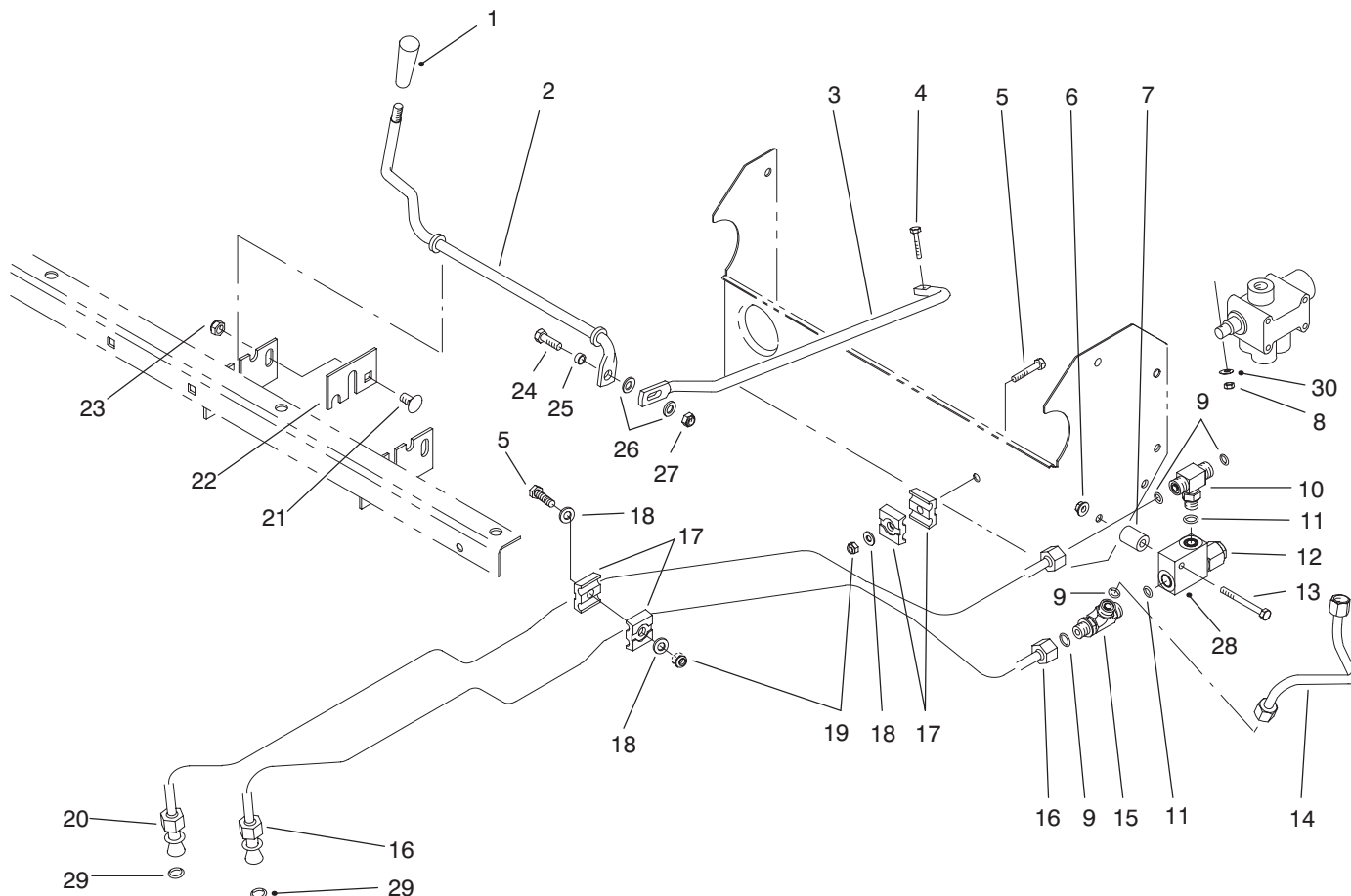

T-1610-1

LIFT VALVE LINKAGE ASSEMBLY

Ref. No.	Part No.	Description	No. Used	Ref. No.	Part No.	Description	No. Used
1	233-39	Knob	1	17	56-7973	Clamp - Hydraulic Tube	4
2	87-4500	Rod - Pivot	1	18	3256-22	Washer - Flat	3
3	87-4510	Rod - Connecting	1	19	3296-42	Nut - Lock	2
4	87-5150	Screw - Cap Hex. Hd.	1	20	87-4540	Hydraulic Tube Assembly (Incl. Ref. #29)	1
5	321-9	Screw - Cap Hex. Hd.	2	21	3231-21	Bolt - Carriage	2
6	32128-33	Nut - Flange Lock	1	22	87-4490	Bracket - Hold-Down	2
7	75-9610	Spacer	1	23	3296-39	Nut - Lock	2
8	87-5140	Nut - Lock	1	24	322-5	Screw - Cap Hex. Hd.	1
9	237-22	Seal - O-Ring	4	25	87-5080	Spacer - Connecting	1
10	340-94	Fitting - Hydraulic Tee (Incl. Ref. #9 & 11)	1	26	3256-23	Washer - Flat	2
11	237-42	Seal - O-Ring	2	27	3296-29	Nut - Lock	1
12	92-2160	Cartridge - Relief Valve	1	28	92-2161	Body - Relief Valve	1
13	321-15	Screw - Cap Hex. Hd.	1	29	39-7310	Seal - O-Ring	2
14	87-4560	Tube - Hydraulic	1	30	3256-14	Washer - Flat	1
15	340-86	Fitting - Hydraulic Tee (Incl. Ref. #9 & 11)	1	*	87-3680	Relief Valve Assembly (Incl. Ref. #12 & 28)	1
16	87-9350	Hydraulic Tube Assembly (Incl. Ref. #29)	1				

*Not Illustrated

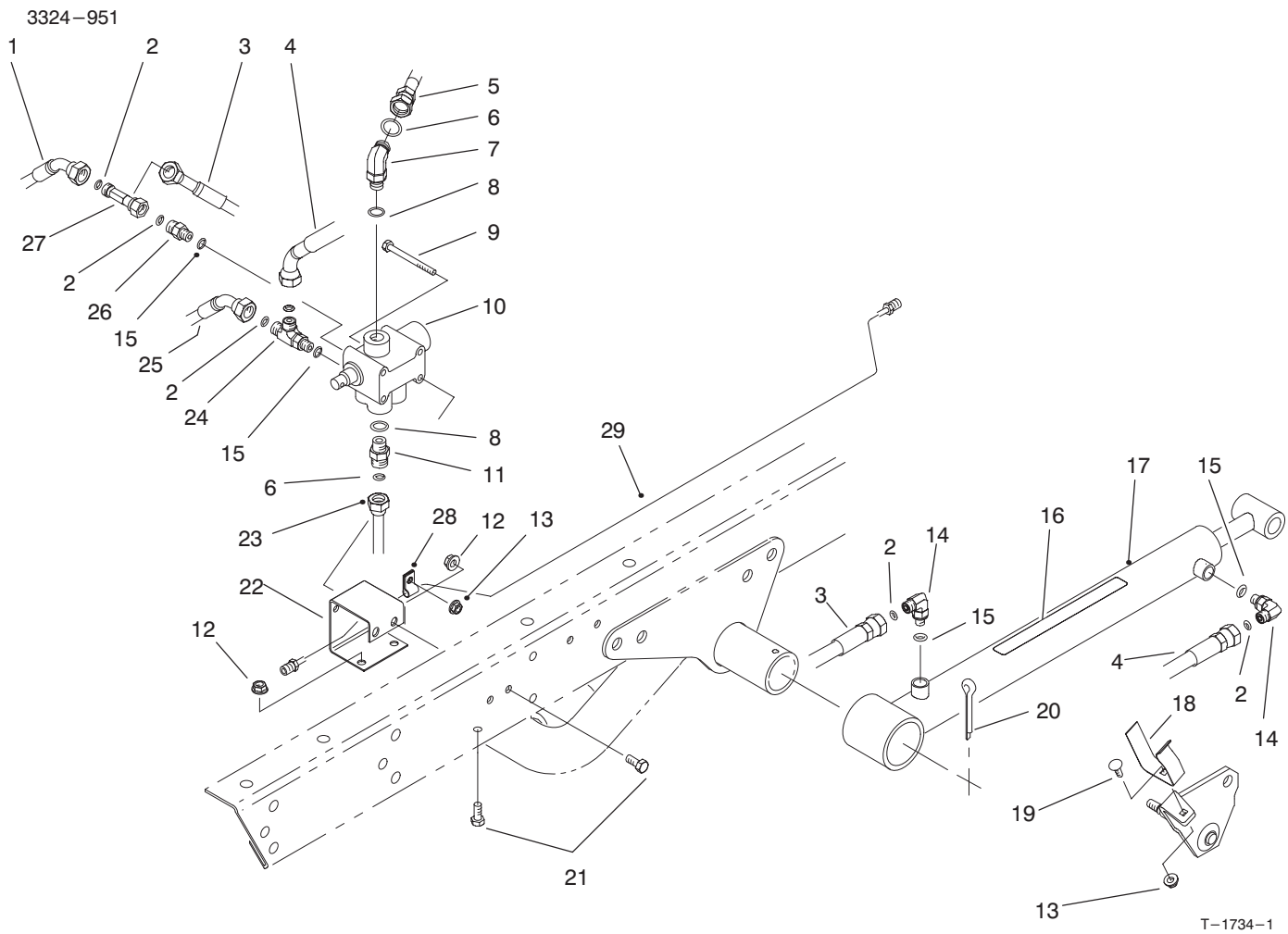

LIFT VALVE & CYLINDER ASSEMBLY

Ref. No.	Part No.	Description	No. Used
1	87-4900	Hose - Hydraulic	1
2	237-21	Seal - O-Ring	6
3	87-4880	Hose - Hydraulic	1
4	92-2697	Hose - Hydraulic	1
5	87-8020	Hose - Hydraulic	1
6	237-22	Seal - O-Ring	2
7	340-77	Fitting - Hydraulic 90° (Incl. Ref. #6 & 8)	1
8	237-42	Seal - O-Ring	2
9	321-14	Screw - Cap Hex. Hd.	2
10	43-1950-03	Valve	1
11	340-2	Fitting - Straight	1
12	32128-20	Nut - Flange Head	4
13	32128-33	Nut - Flange Head	4
14	340-132	Fitting - Hydraulic 90° (Incl. Ref. #2 & 15)	4
15	237-78	Seal - O-Ring	4
16	87-7930	Decal - Warning	2

Ref. No.	Part No.	Description	No. Used
17	94-5203	Hydraulic Cylinder Assy. (Incl. Ref. #16)	2
18	87-3720	Retainer - Cylinder	2
19	3229-1	Screw - Carriage	2
20	3272-37	Pin - Cotter	2
21	322-3	Screw - Cap Hex. Hd.	4
22	87-4520-03	Bracket - Dump Valve	1
23	87-4560	Hose - Hydraulic	1
24	340-140	Fitting - Hydraulic Tee (Incl. Ref. #2 & 15)	1
25	87-4910	Hose - Hydraulic	1
26	340-92	Fitting - Hydraulic Straight (Incl. Ref. #2 & 15)	1
27	340-151	Fitting - Hydraulic Tee (Incl. Ref. #2)	1
28	2412-149	Clamp - R	1
29	94-3844	Tube - Brake Line	1

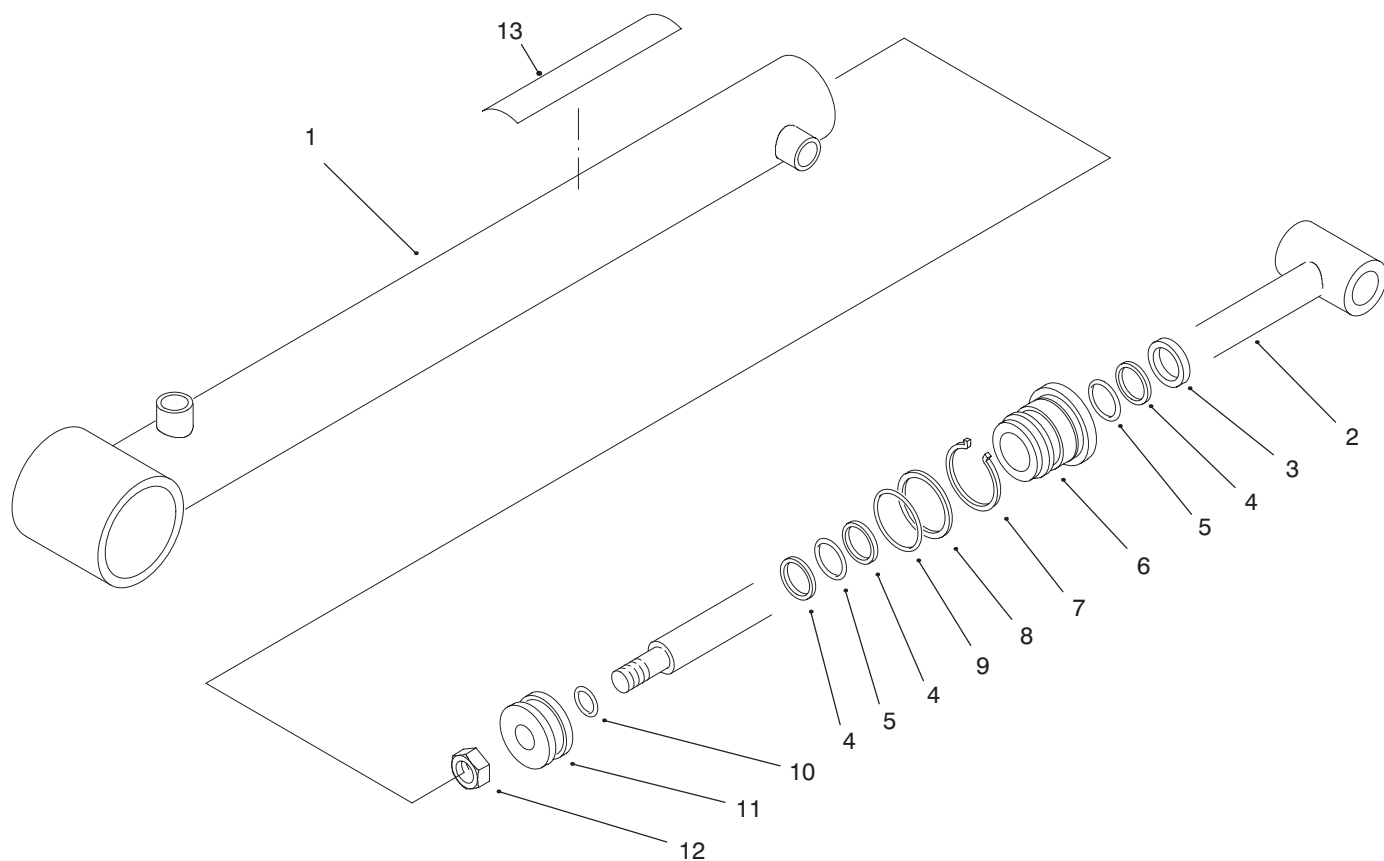

T-2342-1

LIFT CYLINDER NO. 94-5203

Ref. No.	Part No.	Description	No. Used	Ref. No.	Part No.	Description	No. Used
1	94-5206	Barrel Assembly	1	9		Seal - O-Ring	2
2	94-5207	Shaft	1	10		Seal - O-Ring	1
3		Seal - Dust	1	11	43-5150	Piston	1
4		Backup	1	12	32152-10	Nut	1
5		Seal - O-Ring	1	13	87-7930	Decal - Warning	1
6	92-2162	Head	1	*	92-2165	Kit - Repair (Incl. Ref. #3-5 & 8-10)	1
7	84-1680	Ring - Retaining	1				
8		Backup	3				

PROTOTYPE

*Not Illustrated

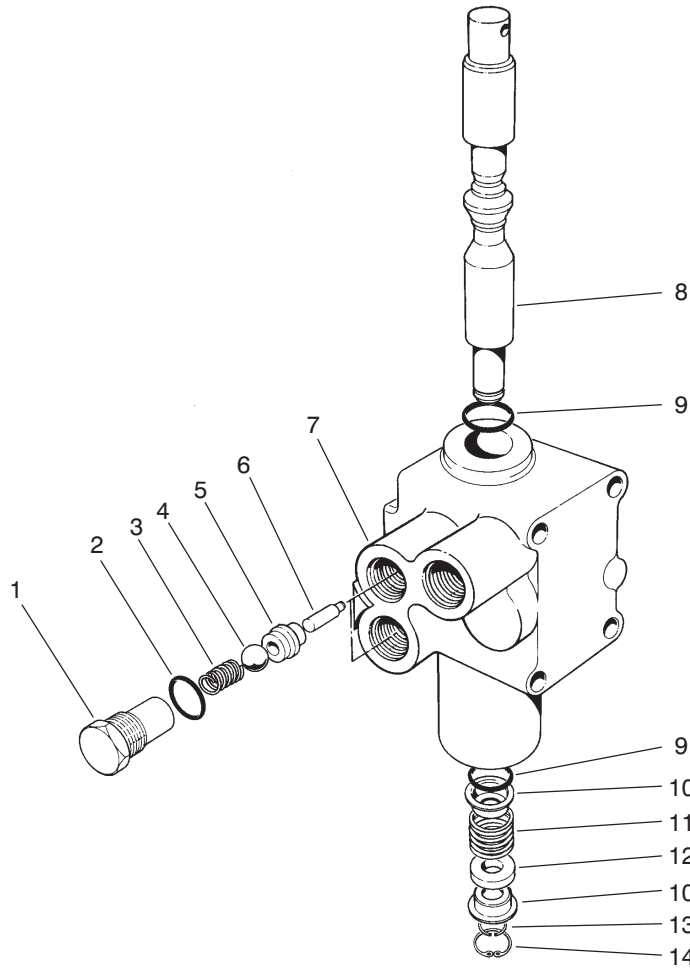

T-0280-1

CONTROL VALVE ASSEMBLY NO. 43-1950

Ref. No.	Part No.	Description	No. Used
1	22-8330	Plug	2
2	237-42	O-Ring	2
3	22-8340	Spring	2
4	22-8350	Ball	2
5	22-8370	Seat-Check Valve	2
6	22-8360	Pin - Cam	2
7		Body	1

Ref. No.	Part No.	Description	No. Used
8	22-8420	Spool	1
9	22-8500	O-Ring	2
10	22-8380	Retainer - Spring	2
11	22-8410	Spring	1
12	23-3030	Spacer	1
13	22-8480	Ring - Retaining, Spool	1
14	22-8490	Ring - Retaining	1

PROTOTYPE

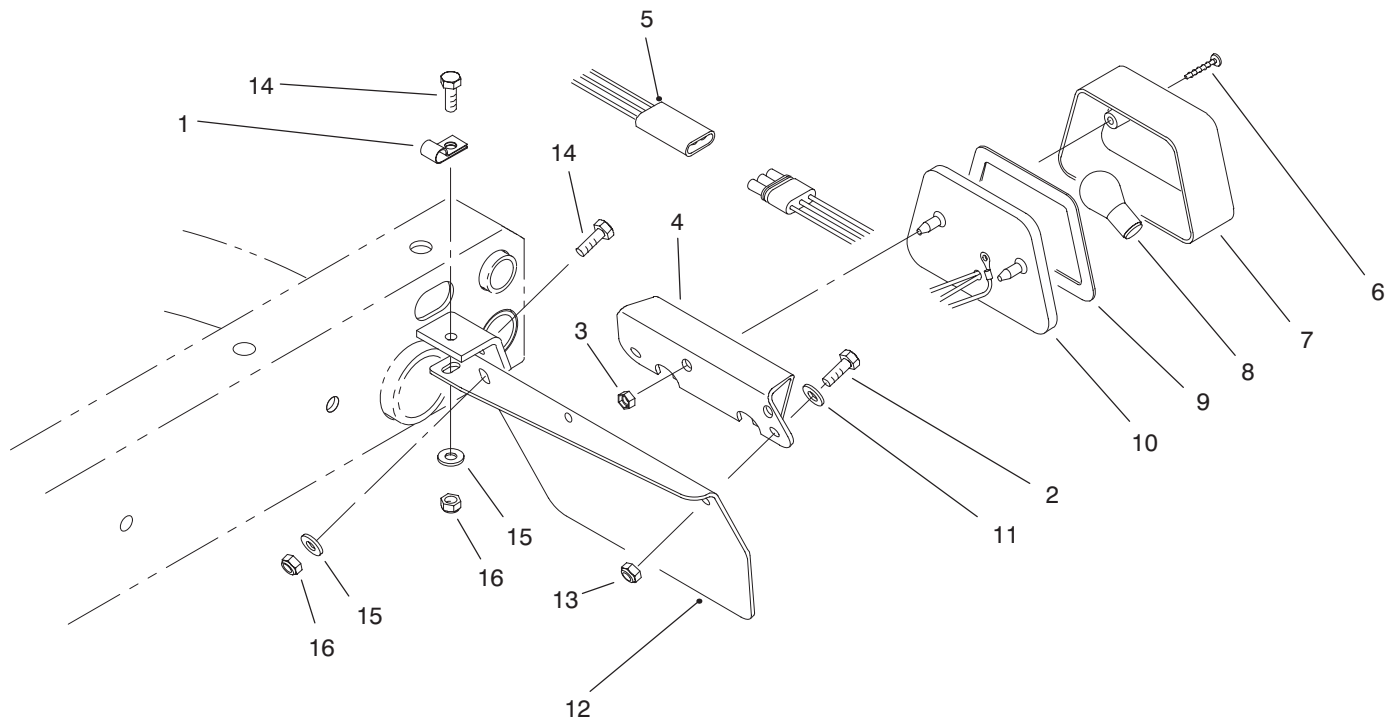

T-1805-1

TAIL LIGHT ASSEMBLY

Ref. No.	Part No.	Description	No. Used	Ref. No.	Part No.	Description	No. Used
1	2412-93	Clamp - R	1	9	87-6310	Gasket	1
2	321-6	Screw - Cap Hex. Hd.	2	10	87-2110	Tail Light Assembly (Incl. Ref. #6-9)	1
3	3290-506	Palnut	2	11	3256-22	Washer - Flat	2
4	87-5770-03	U-Bracket - Tail Light	1	12	93-8943-03	Plate - Tail Light LH	1
5	87-8010	Harness - Wire Rear	1	13	3296-42	Nut - Lock	2
6	32144-93	Screw - Self Tapping	2	14	322-5	Screw - Cap Hex. Hd.	2
7	87-6300	Lens	1	15	3256-23	Washer - Flat	2
8		Bulb (#1157 Std. 12 Volt)	1	16	3296-29	Nut - Lock	2

PROTOTYPE

*Not Illustrated

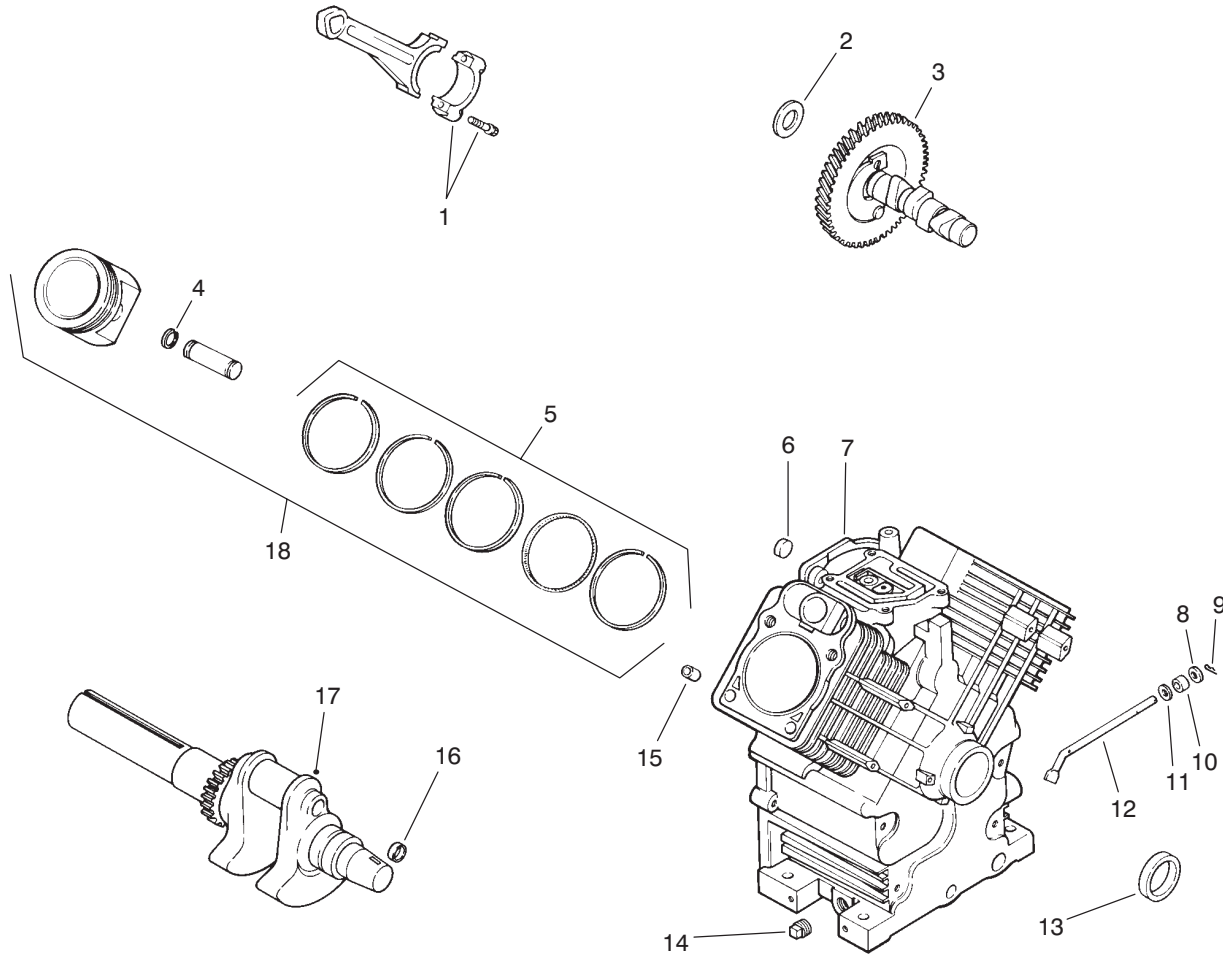

T-1819-1

ENGINE KOHLER MODEL CH22S SPEC. NO. 66513

Ref. No.	Part No.	Description	No. Used
1	24 067 01	Rod - Connecting (Std.)	2
*	24 067 02	Rod - Connecting (.25)	2
2	12 422 09	Shim - Camshaft	A/R
*	12 422 13	Shim - Camshaft	A/R
*	12 422 07	Shim - Camshaft	A/R
*	12 422 08	Shim - Camshaft	A/R
*	12 422 10	Shim - Camshaft	A/R
*	12 422 11	Shim - Camshaft	A/R
*	12 422 12	Shim - Camshaft	A/R
3	24 012 05	Camshaft	1
4	24 018 01	Retainer - Piston Pin	4
5	24 108 01	Piston Ring Set (Std.)	2
*	24 108 02	Piston Ring Set (.25)	2
*	24 108 03	Piston Ring Set (.50)	2
6	52 139 09	Plug - Cup	1
7	24 522 152	Short Block Assembly	1
8	M-931010	Washer - Plain	1

Ref. No.	Part No.	Description	No. Used
9	24 018 09	Retaining Ring	1
10	28 032 09	Seal - Governor Shaft	1
11	24 468 15	Washer	1
12	24 144 33	Shaft - Governor Cross	1
13	24 032 01	Seal - Oil	1
14	X-27-10	Plug - Square Hd.	2
15	12 380 03	Pin - Dowel	6
16	52 139 09	Plug - Cup	1
17	24 014 26	Crankshaft	1
18	24 874 01	Piston & Ring Set (Std.) (Incl. Ref. #4 & 5)	2
*	24 874 02	Piston & Ring Set (.25) (Incl. Ref. #4 & 5)	2
*	24 874 03	Piston & Ring Set (.50) (Incl. Ref. #4 & 5)	2
*	24 755 03	Gasket Set	1

*Not Illustrated

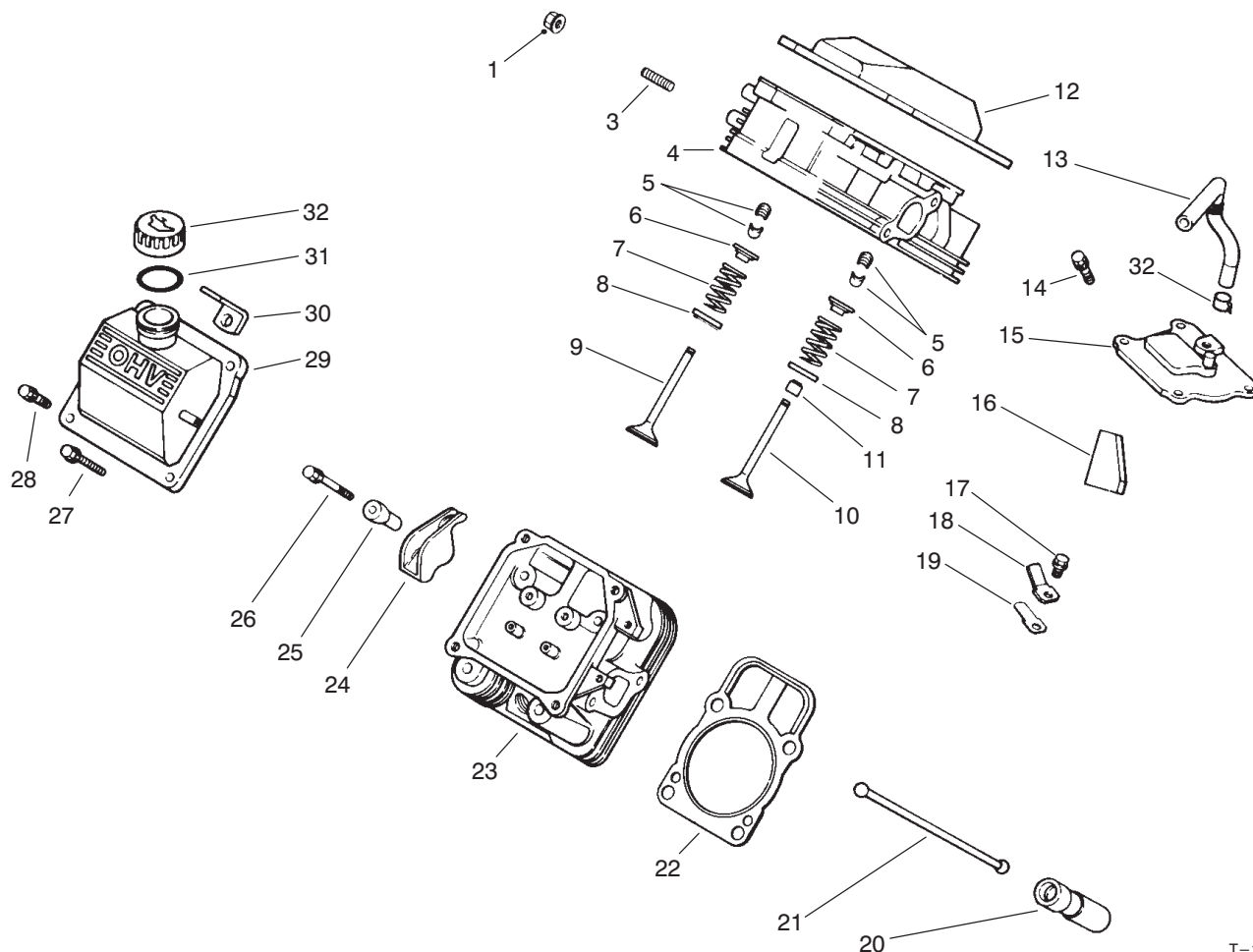

T-1820-1

ENGINE KOHLER MODEL CH22S SPEC. NO. 66513 (Cont.)

Ref. No.	Part No.	Description	No. Used
1	M-0841080	Nut	4
3	M-0829033	Stud - Exhaust Manifold	4
4	24 318 09	No. 1 Cylinder Head Assy.	1
5	12 755 03	Retainer Kit	4
6	12 173 01	Cap - Valve Spring	4
7	24 089 02	Spring - Valve	4
8	52 018 01	Retainer - Spring	4
9	24 016 01	Valve - Exhaust	2
10	24 017 01	Valve - Intake	2
11	24 032 05	Seal - Valve Stem	2
12	24 096 11	Cover - Rocker	1
13	24 326 02	Hose - Breather	1
14	SM-0645020	Screw	4
15	24 033 01	Breather & Plug Kit	1
16	24 050 01	Filter - Breather	1
17	M-0545010	Screw - Breather	1
18	12 018 01	Retainer - Breather Reed	1

Ref. No.	Part No.	Description	No. Used
19	24 402 03	Reed - Breather	1
20	12 351 01	Lifter - Valve	4
21	24 411 02	Rod - Push	4
22	24 041 08	Gasket - Cylinder Head	2
23	24 318 10	No. 2 Cylinder Head Assy.	1
24	24 186 02	Arm - Rocker	2
25	24 194 01	Ball - Pivot Rocker	2
26	M-0640034	Screw	1
27	12 086 16	Screw	8
28	M-0651030	Screw	8
29	24 096 12	Cover - Rocker	1
30	12 445 05	Strap - Lifting	2
31	12 153 03	Seal - O-Ring	1
32	24 755 46	Oil Fill Cap Kit (Incl. Ref. #31)	1
33	X-426-9	Clamp - Breather	1

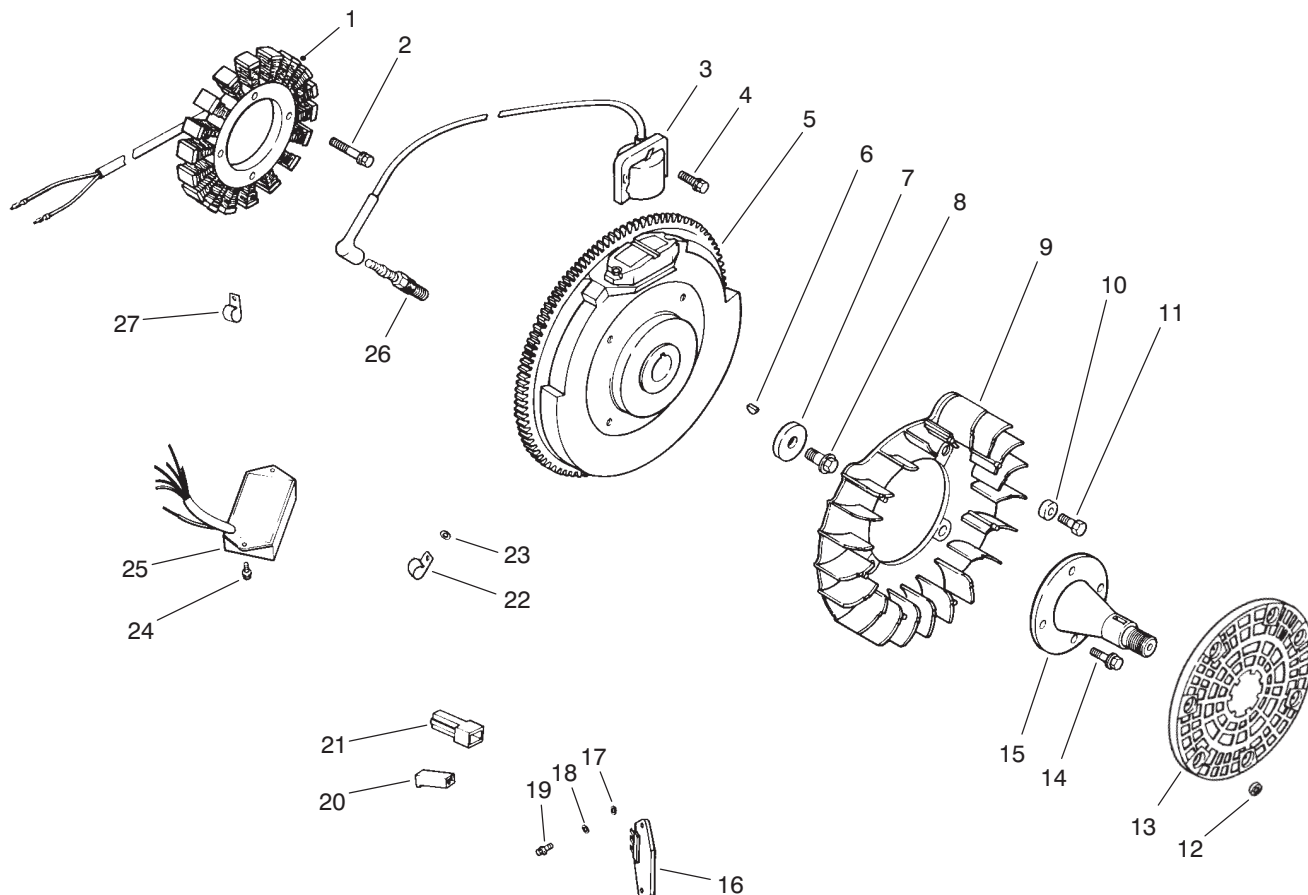

T-1822-1

ENGINE KOHLER MODEL CH22S SPEC. NO. 66513 (Cont.)

Ref. No.	Part No.	Description	No. Used	Ref. No.	Part No.	Description	No. Used
1	12 085 02	Stator - 30 Amp.	1	16	25 403 01	Rectifier/Regulator 25 Amp.	1
2	M-0548025	Screw	2	17	X-25-92	Washer - Plain	2
3	24 584 03	Module - Ignition	2	18	X-25-63	Washer - Plain	1
4	M-0560020	Screw	4	19	24 086 18	Screw - Phillips	2
5	24 025 02	Flywheel Assembly	1	20	25 155 04	Connector - 1 Contact	1
6	X-42-15	Key	1	21	25 155 03	Connector - 1 Contact	1
7	12 468 03	Washer - Flywheel	1	22	47 154 01	Clip - Cable	1
8	12 086 14	Screw - Flywheel	1	23	X-25-63	Washer - Plain	1
9	24 157 01	Fan	1	24	M-0448010	Screw	2
10	12 112 01	Spacer - Fan	4	25	24 584 04	Module - Speed Advance	1
11	M-0639016	Screw	4	26	12 132 02	Plug - Spark	2
12	24 018 03	Retainer	3	27	48 154 02	Clip - Cable	1
13	24 162 16	Screen - Grass	1	*	24 176 28	Harness - Wire	1
14	M-0839025	Screw	4	*	24 518 04	Lead - Green (Rect.-Reg. 4" 18 Ga.)	1
15	24 144 17	Shaft - Front Drive	1				

*Not Illustrated

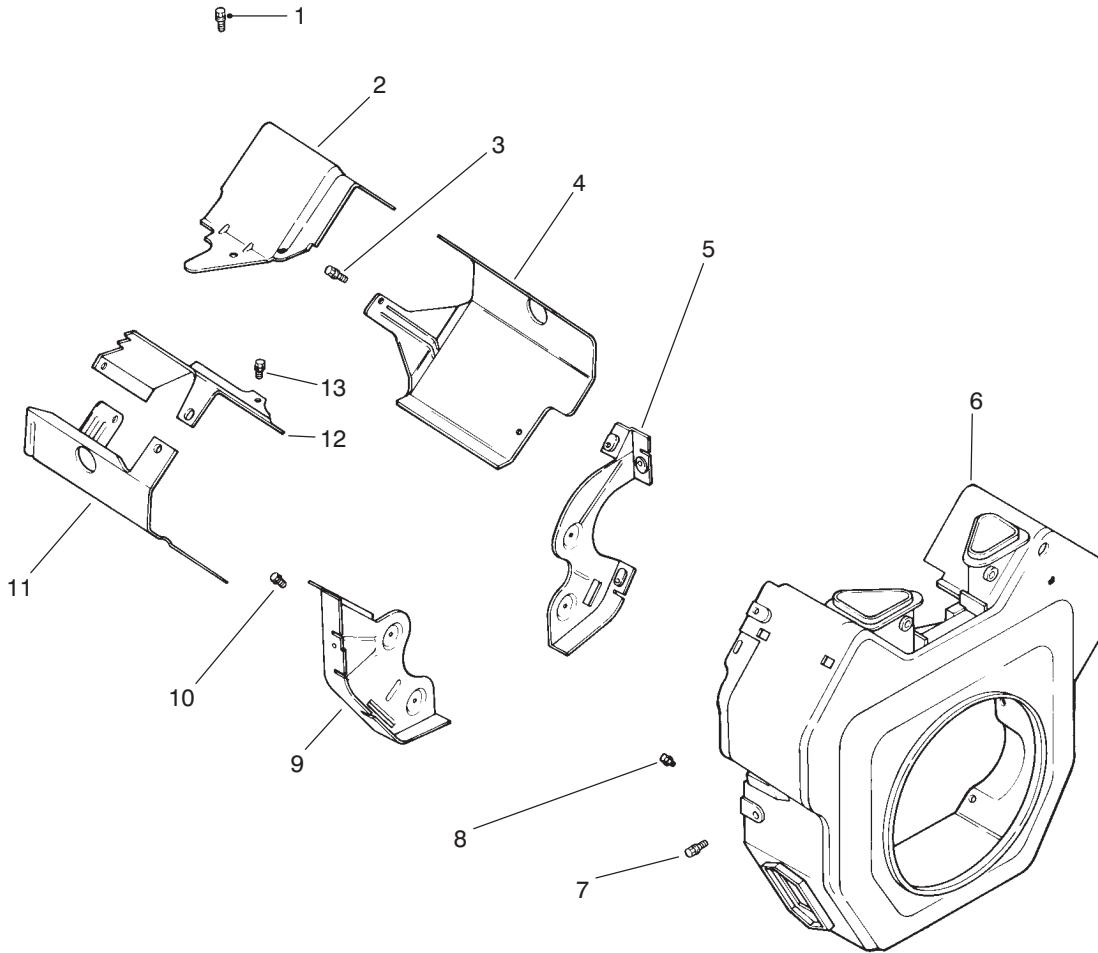

T-1823-1

ENGINE KOHLER MODEL CH22S SPEC. NO. 66513 (Cont.)

Ref. No.	Part No.	Description	No. Used
1	M-0549016	Screw	2
2	24 063 17	Baffle - Valley (No. 2 Side)	1
3	M-0549016	Screw	2
4	24 063 20	Baffle - Cylinder Barrel (No. 2 Side)	1
5	24 146 01	Plate - Backing (No. 1 Side)	1
6	24 027 04	Housing - Blower	1
7	M-0549016	Screw	5

Ref. No.	Part No.	Description	No. Used
8	M-0551016	Screw	1
9	24 146 02	Plate - Backing (No. 2 Side)	1
10	SM-0645016	Screw	4
11	24 063 19	Baffle - Cylinder Barrel (No. 1 Side)	1
12	24 063 18	Baffle - Valley (No. 1 Side)	1
13	M-0649016	Screw	2
*	24 113 13	Decal - Horsepower	1

*Not Illustrated

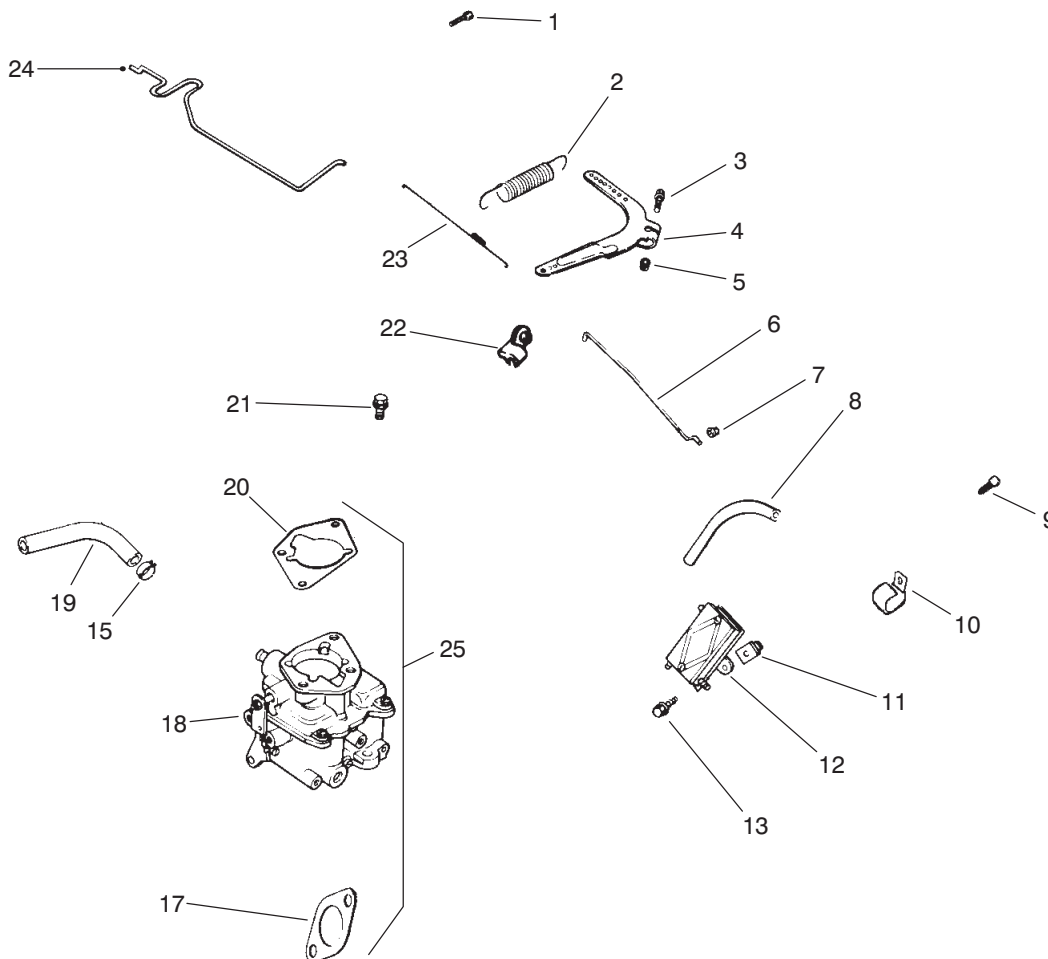

T-1824-1

ENGINE KOHLER MODEL CH22S SPEC. NO. 66513 (Cont.)

Ref. No.	Part No.	Description	No. Used
1	SM-0645016	Screw	4
2	24 089 15	Carriage Bolt	1
3	24 211 03	Screw	1
4	24 090 33	Lever - Governor	1
5	SM-0641060	Nut	1
6	24 079 01	Linkage - Throttle	1
7	25 158 08	Bushing - Linkage	1
8	24 353 02	Line - Fuel 15.5"	1
9	M-0650012	Screw - Clip	1
10	47 154 01	Clip - Cable	1
11	24 100 01	Nut	2
12	24 393 04	Pump - Fuel	1
13	24 086 12	Screw	2

Ref. No.	Part No.	Description	No. Used
15	X-426-9	Clamp - Hose	4
17	24 041 17	Gasket - Carburetor	1
18	24 053 17	Carburetor Assembly (For information only, not available seperatly)	1
19	25 353 10	Line - Fuel 9"	1
20	24 041 06	Gasket - Air Cleaner Base	1
21	M-0651030	Screw	2
22	25 158/11	Bushing - Linkage	1
23	24 089 01	Spring - Linkage	1
24	24 079 05	Linkage - Choke	1
25	24 853 20	Carburetor & Gasket Kit (Incl. Ref. #17, 18 & 20)	1

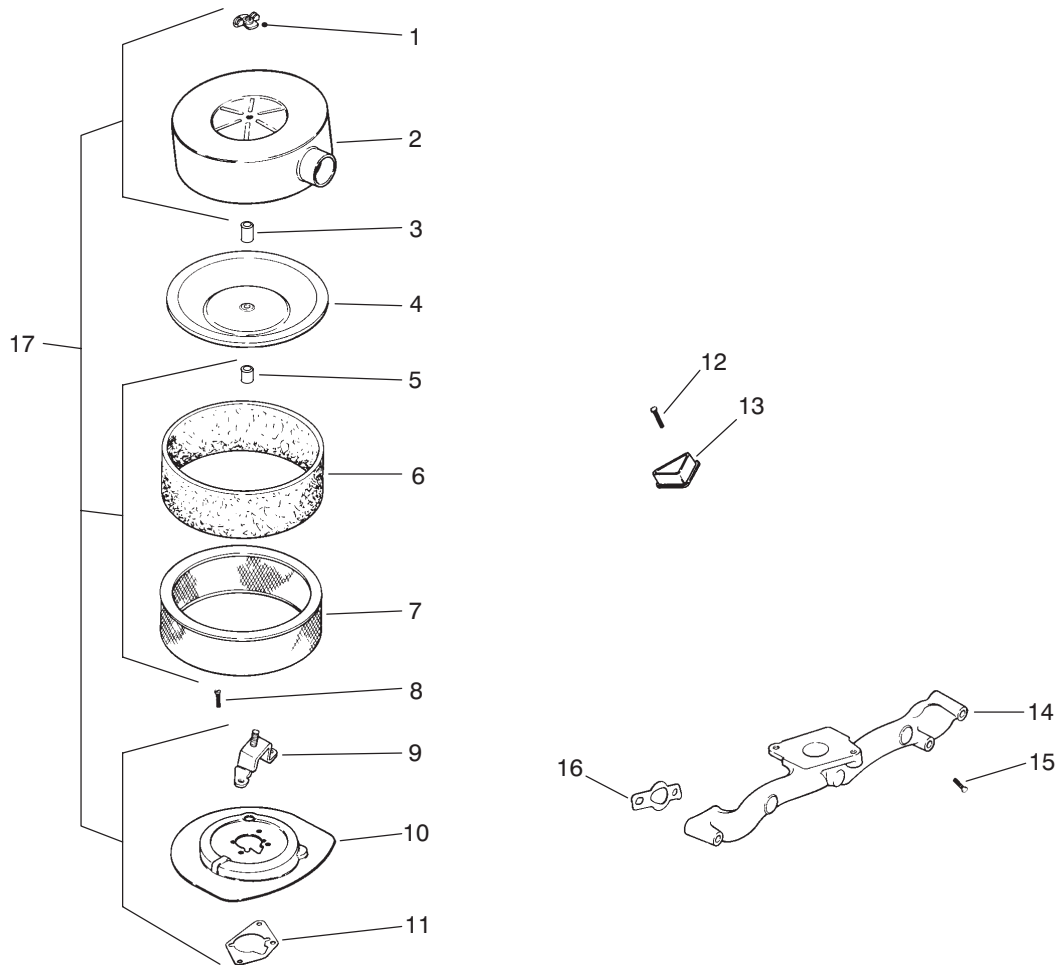

T-1825-1

ENGINE KOHLER MODEL CH22S SPEC. NO. 66513 (Cont.)

Ref. No.	Part No.	Description	No. Used
1	12 100 01	Nut – Wing	2
2	24 096 10	Cover – Air Cleaner	1
3	41 032 02	Seal – Insert	1
4	24 096 01	Cover – Inner Air Cleaner	1
5	230046	Seal – Air Intake	1
6	24 083 02	Element – Precleaner	1
7	47 083 03	Element – Air Cleaner	1
8	M-0650825	Screw	3
9	24 126 22	Bracket – Air Cleaner	1
10	24 041 06	Gasket – Air Cleaner Base	1

Ref. No.	Part No.	Description	No. Used
11	24 094 05	Base – Air Cleaner	1
12	15 086 09	Screw	2
13	24 096 17	Cover – Blower Housing	2
14	24 164 14	Manifold – Intake	1
15	M-0639055	Screw	4
16	24 041 01	Gasket – Intake Manifold	2
17	24 755 21	Grass Deflection Kit (Incl. Ref.#1, 2, 5-7 & 9-11)	1
*	24 113 14	Decal – Maintenance	1

*Not Illustrated

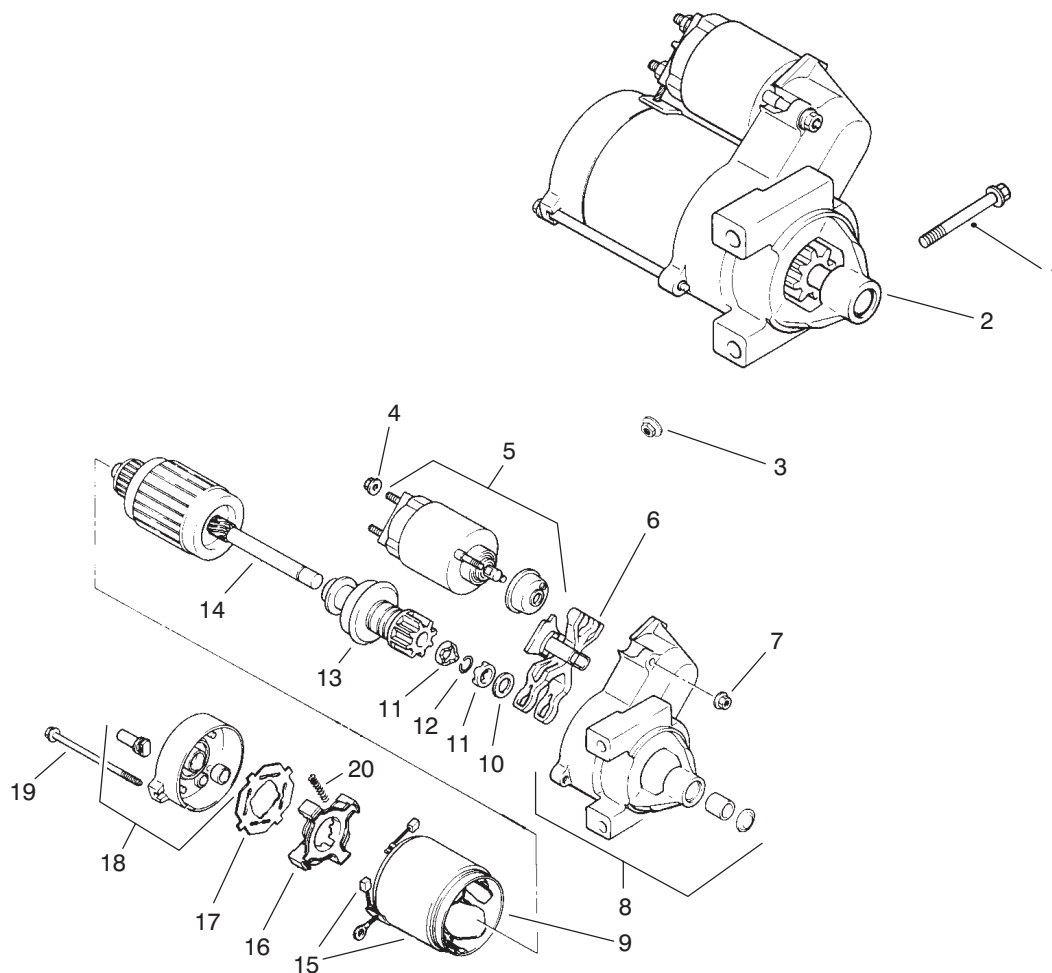

T-1826-1

ENGINE KOHLER MODEL CH22S SPEC. NO. 66513 (Cont.)

Ref. No.	Part No.	Description	No. Used	Ref. No.	Part No.	Description	No. Used
1	M-0839080	Screw	2	11	52 100 08	Nut - Stop Collar	2
2	24 098 01	Starter - Solenoid Shift (Incl. Ref. #4-20)	1	12	52 141 03	Ring - Retainer	1
3	M-0841080	Nut	1	13	12 239 01	Drive - Pinion	1
4	52 100 09	Nut - Starter	1	14	12 170 03	Armature - Starter	1
5	52 435 02	Solenoid	1	15	52 221 01	Brush Kit	1
6	12 090 10	Lever - Starter Drive	1	16	52 323 03	Holder - Brush	1
7	52 100 10	Nut - Starter	2	17	52 168 01	Insulator	1
8	24 081 04	Drive - End Cap	1	18	24 301 01	Commutator - End Cap	1
9	12 471 01	Frame	1	19	52 211 05	Bolt - Thru	2
10	52 468 14	Washer - Thrust	1	20	52 089 09	Spring - Brush	4

PRODUCT CHANGES

In an effort to make improvements available to TORO owners as quickly as possible, minor changes are incorporated into Toro's products from time to time that do not become immediately shown in the Parts Catalog. If such a change has been made in your unit, which is not reflected in your manual, see your TORO Distributor or his Authorized TORO Service Dealer for information and part numbers.

IDENTIFICATION AND ORDERING

MODEL AND SERIAL NUMBERS

The Workman 3100 has two identification numbers; a model number and a serial number. The two numbers are stamped on a plate which is located on the main frame. In any correspondence concerning the Workman 3100, supply model and serial numbers to assure that correct information and replacement parts are obtained.

To order replacement parts from an Authorized TORO Service Dealer, supply the following information:

1. Model and serial number of the Workman 3100.
2. Part number, description, and the quantity of part(s) desired.

NOTE: Do not order by reference number if a parts catalog is being used; use the PART NUMBER.

TABLE OF CONTENTS

Description	Page	Description	Page
Front Bumper & Hood Assembly	1	Rear Brake Assembly	24
Control Panel Assembly	2	Engine Frame & Hydraulic Pump Assembly	25
Electrical Schematic	3	Hydraulic Pump Assembly No. 87-5700	26
Steering Linkage Assembly	4	Engine Installation Assembly	27
Steering Gear Assembly No. 87-1500	5-6	Throttle Linkage Assembly	28
Brake & Accelerator Pedal Assembly	7	Muffler & Relay Assembly	29
Master Brake Cylinder No. 94-3800	8	Transaxle Installation Assembly	30-31
Hydraulic Brake Line Routing Assembly	9	Transaxle Case Assembly	32
Hydraulic Schematic	10	Countershaft Assembly	33
Clutch Linkage Assembly	11	Transaxle Gear Shafts Assembly	34
Seat Base Assembly	12	Shift Fork Assembly	35
Seat Back Assembly	13	Differential Gear Assembly	36
Hi-Lo Shift Levers Assemblies	14	Battery Mount Assembly	37
Differential Lock & Parking Brake Assemblies	15	Fuel Tank Assembly	38
R.O.P.S. Assembly	16	Lift Valve Linkage Assembly	39
Front Suspension Assembly	17	Lift Valve & Cylinder Assembly	40
Front Suspension Control Arm Assembly	18	Lift Cylinder No. 94-5203	41
Front Wheel Assembly	19	Control Valve Assembly No. 43-1950	42
Front Brake Assembly	20	Tail Light Assembly	43
Rear Frame Assembly	21	Engine	
Rear Axle Assembly	22-23	Kohler Model CH22S Spec. No. 66513	44-51