



Trencher
Dingo® Attachment
Model No. 22447—210000001 and Up

Parts Catalog

Ordering Replacement Parts

To order replacement parts, please supply: the part number, the quantity, and the description of each part desired.

Understanding Reference Numbers

Each identified part in an illustration has a reference number. The reference number for a part also appears in the parts list, along with other information about the part.

This catalog uses two special reference number formats, one to indicate parts in a service assembly and another to indicate the quantity of a given part in an illustration.

Service Assembly Reference Numbers

Parts in service assemblies have reference numbers in the form **a:b**. The **a** represents the reference number of the entire service assembly and the **b** represents a sequential number unique to each part within the service assembly.

For example, a wheel assembly might be identified by reference number **6**, the tire by **6:1**, the valve by **6:2**, and the wheel by **6:3**. When you order the assembly identified by reference number **6**, you receive all parts identified by reference numbers **6:1**, **6:2**, and **6:3**. However, you may also order any part individually.

Reference numbers of this type appear in illustrations and in part lists.

Reference Numbers Indicating Quantity

In an illustration, if a reference number indicates more than one part, the reference number has the form **nX y**. The **n** represents the quantity of the part, the **X** is the multiplication symbol, and the **y** represents the reference number.

For example, in an illustration, the reference number **2X 37** means that two of the parts identified by reference number **37** are indicated.

Contents

Description	Page	Description	Page
Trencher Assembly	3		
Trencher Drive Assembly	4		

Accessories

Description	Model / Part No.	Description	Model / Part No.
4" 1/2 & 1/2 Chain	22462	8" Chain	22468
6" 1/2 & 1/2 Chain	22463	12" Chain	22469
4" Chain	22466	Crumber	22464
6" Chain	22467		

Part Description Abbreviations

Part descriptions in this catalog may include the following abbreviations.

Abbreviation	Meaning	Abbreviation	Meaning
AR	as required	INC	incorporated
ASM	assembly	LH	left hand
CARR	carriage	NI	nylon insert
DEG	degrees	PPH	Phillips pan head
FH	flat head	PTH	Phillips truss head
GA	gauge	PTO	power take off
HF	hex flange	RH	right hand
HH	hex head	SFH	slotted fillister head
HHF	hex head flange	SHH	slotted hex head
HLH	hex lag head	SQH	square head
HJ	hex jam	SHWH	slotted hex washer head
HOC	height-of-cut	SPH	slotted pan head
HS	hex socket	SRH	slotted round head
HSBH	hex socket button head	STD	standard
HSFH	hex socket flat head	TAP	self tapping
HSH	hex socket head	TTH	Torx truss head
HWH	hex washer head	WH	wing head
HWHTF	hex washer head thread forming		

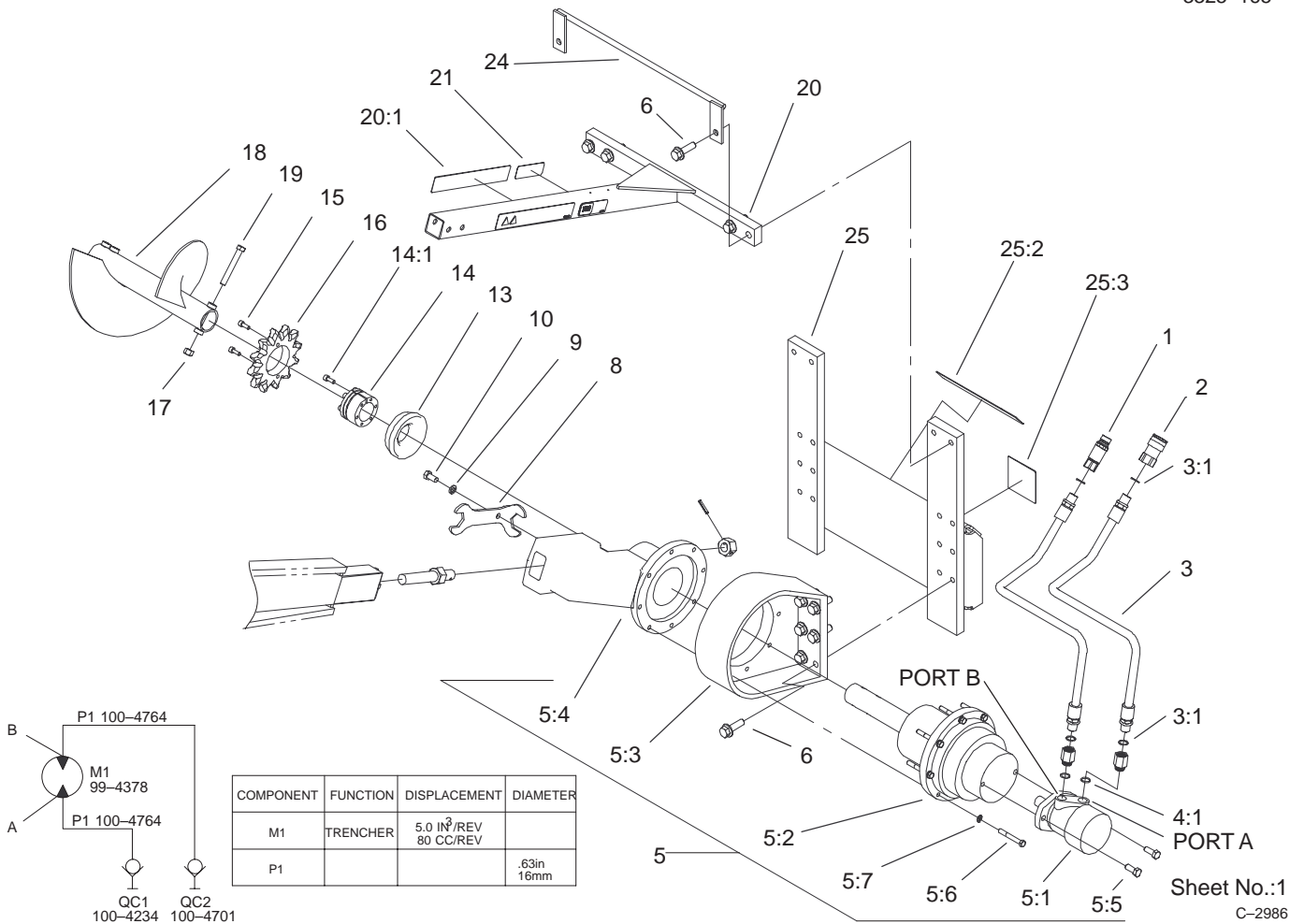

Sheet No.:1
C-2986

Trencher Assembly

Ref. No.	Part No.	Qty.	Description
1	100-4701	1	Nipple-Connect, Pressure
*1:1	100-6120	1	Kit-Seal
2	100-4234	1	Coupler-Face, Flush
*2:1	100-6119	1	Kit-Seal
3	100-4764	2	Hose-Hydraulic
3:1	237-80	2	O-Ring
4	100-4763	2	Adapter-Conversion
4:1	99-4368	1	O-Ring
☆5		1	Trencher Drive ASM
5:1	104-5854	1	Motor-Hyd, 80cc (1 Inch Shaft)
5:1	99-4378	1	Motor-Hyd(Optional), 100cc-1 Inch Shaft
5:1	104-5864	1	Motor-Hyd(Optional), 80cc-32mm Shaft
5:1	104-5865	1	Motor-Hyd(Optional), 100cc-32mm Shaft
*5:1:1	99-4376	2	Kit-Seal, Motor
5:2	99-4358	1	Gearbox ASM
*5:2:1	99-4375	1	Seal-Oil
*5:2:2	99-4374	2	O-Ring
*5:2:3	99-4377	1	Set-Gear, Gearbox
5:3	99-4320	1	Mount-Drive, Planetary
5:4	99-4321	1	Mount-Boom

Ref. No.	Part No.	Qty.	Description
5:5	325-29	2	Screw-HH, LH
5:6	323-14	8	Screw-HH
5:7	3253-5	8	Washer-Lock
6	104-5870	10	Screw
*7	104-1997	1	Trencher Boom ASM
8	99-4323	1	Spanner
9	3253-7	1	Washer-Lock
10	325-4	1	Screw-HH
13	99-4367	1	Protector-Seal
14	99-4334	1	Lock-Taper
14:1	92-5697	6	Screw-HSH
15	3274-18	2	Screw-HSH
16	100-1699	1	Sprocket-12t
17	3296-23	1	Nut-Lock, NI
18	104-1916-03	1	Auger ASM,
19	325-35	1	Screw-HH
20	99-4326	1	Safety Rail ASM
20:1	99-9952	2	Decal-Danger
21	98-4683	2	Decal-Attachment, Dingo
24	99-4331-03	1	Hose Guide ASM
25	104-5853	1	Mounting ASM
25:2	99-9952	1	Decal-Danger
25:3	99-9953	1	Decal-Danger

* Not illustrated

☆ Not serviced

