



Greensmaster[®] 3100
2 Wheel Drive Traction Unit
Model No. 04356—20000001 and Up

Parts Catalog

Ordering Replacement Parts

To order replacement parts, please supply: the part number, the quantity, and the description of each part desired.

Understanding Reference Numbers

Each identified part in an illustration has a reference number. The reference number for a part also appears in the parts list, along with other information about the part.

This catalog uses two special reference number formats, one to indicate parts in a service assembly and another to indicate the quantity of a given part in an illustration.

Service Assembly Reference Numbers

Parts in service assemblies have reference numbers in the form **a:b**. The **a** represents the reference number of the entire service assembly and the **b** represents a sequential number unique to each part within the service assembly.

For example, a wheel assembly might be identified by reference number **6**, the tire by **6:1**, the valve by **6:2**, and the wheel by **6:3**. When you order the assembly identified by reference number **6**, you receive all parts identified by reference numbers **6:1**, **6:2**, and **6:3**. However, you may also order any part individually.

Reference numbers of this type appear in illustrations and in part lists.

Reference Numbers Indicating Quantity

In an illustration, if a reference number indicates more than one part, the reference number has the form **nX y**. The **n** represents the quantity of the part, the **X** is the multiplication symbol, and the **y** represents the reference number.

For example, in an illustration, the reference number **2X 37** means that two of the parts identified by reference number **37** are indicated.

Contents

Description	Page
Control Pedal Assembly	4-5
Traction Controls Assembly	6
Front Wheel and Brake Assembly	7
Hydraulic Drive Motor Assembly No. 92-9199 ...	8
Steering Arm Assembly	9
Power Steering Valve No. 92-8690	10
RH Pull Frame Assembly	11
Hydraulic Cylinder Assembly No. 99-8159	12
LH Pull Frame Assembly	13
Rear Pull Frame Assembly	14
Hydraulic Cylinder No. 99-8160	15
Seat Assembly	16-17
Control Valve Installation Assembly	18-19
Engine Installation Assembly	20
Hydraulic Pump Installation Assembly	21
Hydraulic Pump 92-9764	22
Frame Assembly	23

Description	Page
Rear Wheel Assembly	24
Hydraulic Cylinder Assembly No. 83-2330	25
Control Panel Assembly	26
Hydraulic Reservoir Assembly	27
Fuel Tank Assembly	28
Reel Motor Installation Assembly	29
Reel Motor No. 94-3506	30
Electrical Schematic	31
Grass Basket & Miscellaneous Parts	32
Control Valve Assembly No. 84-2203 (Sections 1&2)	33-34
Control Valve Assembly No. 84-2203 (Sections 3 Thru 5)	35-36
Special Tools	37-38
Engine Briggs & Stratton Model 350447-1259-E1	39-52
Hydraulic Schematic	53

Accessories

Description	Model / Part No.
Individual Reel Shut Off Kit	28-2150
Basket Reinforcement Kit	26-0900
Thatching Reels	04493
Variable Speed Kit	04422
Traction Tire	231-124
Armrests	30707
Spiker	04494
Tri-Roller	04495
Backlapping Kit	92-9656
Backlap Kit - 2 Speed, 3 Position	94-1870

Description	Model / Part No.
8 Blade, 4 Bolt (Heavy Duty) Cutting Unit	04404
8 Blade, 4 Bolt Cutting Unit	04408
11 Blade, 4 Bolt Cutting Unit	04406
8 Blade, SPA Cutting Unit	04468
11 Blade, SPA Cutting Unit	04450
8 Blade, 4 Bolt Cutting Unit	04480
11 Blade, 4 Bolt Cutting Unit	04481
8 Blade, SPA Cutting Unit	04482
11 Blade, SPA Cutting Unit	04483
Three Wheel Drive Kit	100-6441

Part Description Abbreviations

Part descriptions in this catalog may include the following abbreviations.

Abbreviation	Meaning	Abbreviation	Meaning
AR	as required	INC	incorporated
ASM	assembly	LH	left hand
CARR	carriage	NI	nylon insert
DEG	degrees	PPH	Phillips pan head
FH	flat head	PTH	Phillips truss head
GA	gauge	PTO	power take off
HF	hex flange	RH	right hand
HH	hex head	SFH	slotted fillister head
HHF	hex head flange	SHH	slotted hex head
HLH	hex lag head	SQH	square head
HJ	hex jam	SHWH	slotted hex washer head
HOC	height-of-cut	SPH	slotted pan head
HS	hex socket	SRH	slotted round head
HSBH	hex socket button head	STD	standard
HSFH	hex socket flat head	TAP	self tapping
HSH	hex socket head	TTH	Torx truss head
HWH	hex washer head	WH	wing head
HWHTF	hex washer head thread forming		

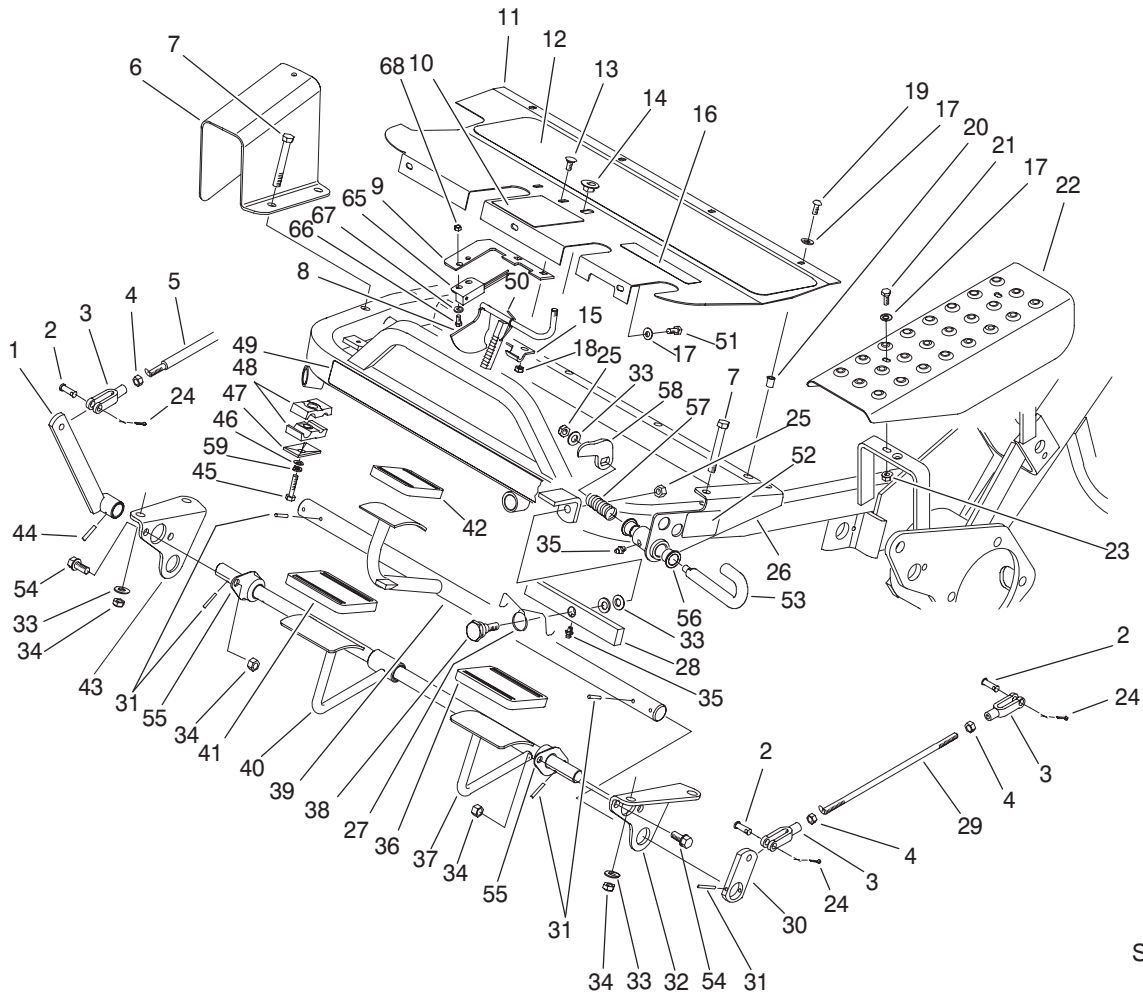

Sheet No.: 2

Control Pedal Assembly

Ref. No.	Part No.	Qty.	Description
1	49-6200-01	1	Lever-Cutting
2	283-61	5	Pin-Yoke
3	282-2	5	Yoke
4	3220-2	5	Nut-HJ
5	49-5430	1	Rod-Control
6	49-6110-01	1	Guard
7	323-13	4	Screw-HH
8	100-9819	1	Latch ASM-Welded
9	100-9821	1	Plate-Reed Switch
10	93-8062	1	Decal-Brake, Parking
11	83-0640-01	1	Plate-Footrest
12	49-6120	1	Pad-Footrest
13	3229-11	2	Screw-CARR
14	32141-111	1	Nut-Adjusting
15	95-1629	1	Hinge - Lower
16	93-8075	1	Decal-Mow/Lift
17	3256-1	9	Washer-Flat
18	3296-16	2	Nut-Lock, NI
19	3274-31	4	Screw-HSBH
20	32148-6	8	Nut-Insert
21	321-4	2	Screw-HH
22	83-0200-01	1	Plate-Cover, LH
23	32128-33	2	Nut-HF
24	3272-6	5	Pin-Cotter
25	3296-39	2	Nut-Lock, NI
26	93-9901-01	1	Bracket-Lockout, Mow

Ref. No.	Part No.	Qty.	Description
27	83-0080	1	Spring-Pivot, Lift
28	83-0060	1	Lift - Pivot
29	27-2270	2	Rod-Adjustment, Brake
30	10-8100-01	2	Strap-Shaft, Brake
31	32121-35	8	Pin-Roll
32	88-9640-01	1	Bracket-Lift Pivot, LH
33	3256-38	7	Washer-Flat
34	3296-59	8	Nut-Lock, NI
35	302-5	2	Fitting - Grease
36	93-7631	1	Pad-Foot, Lift
37	88-9660	1	Shaft-Control, Cut
38	83-2590	1	Bolt-Shoulder, Pivot
39	83-0160	1	Shaft-Brake
40	83-0140	1	Pedal-Mow
41	93-7630	1	Pad-Foot
42	93-7629	1	Pad-Foot, Brake
43	88-9630-01	1	Bracket-Lift Pivot, RH
44	32121-6	1	Pin-Roll
45	321-11	1	Screw-HH
46	3256-22	1	Washer-Flat
47	69-9760	1	Coverplate
48	56-7970	2	Clamp-Tube
49	88-9620	1	Decal-Gr 3100
50	10-8140	1	Bracket-Spring, Latch
51	321-3	3	Screw-HH

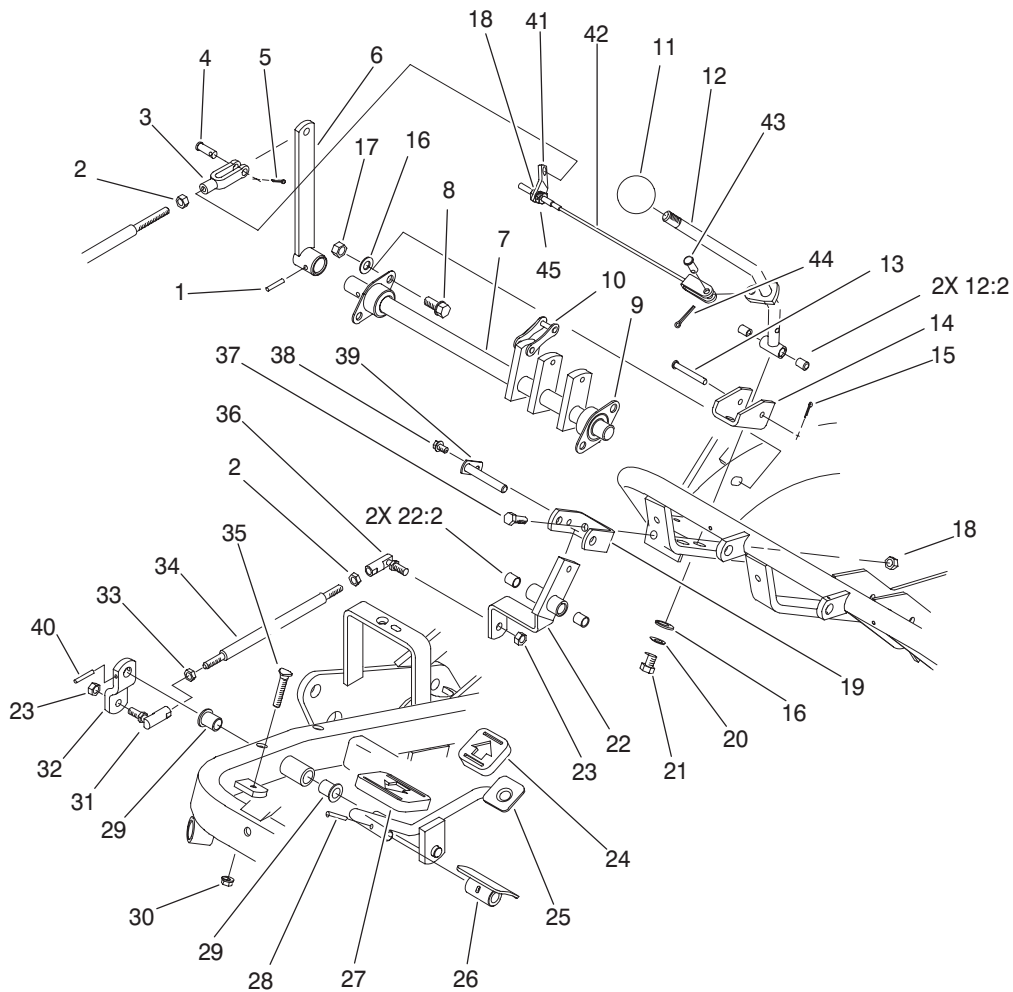

Sheet No.: 3

Traction Controls Assembly

Ref. No.	Part No.	Qty.	Description
1	32121-6	1	Pin-Roll
2	3220-2	3	Nut-HJ
3	282-2	1	Yoke
4	283-61	1	Pin-Yoke
5	3272-6	1	Pin-Cotter
6	47-5320-01	1	Lever
7	44-0870	1	Cam Shaft ASM
8	3234-1	4	Screw-HHF
9	27-2320	2	Bearing
10	57-6220	5	Link-Connecting
11	233-48	1	Knob
12	93-9934	1	Handle-Traction
12:2	256-251	2	Bushing
13	283-57	1	Pin
14	49-6220	1	Bracket-Arm, Control
15	3272-4	1	Pin-Cotter
16	3256-24	6	Washer-Flat
17	3296-59	4	Nut-Lock, NI
18	3296-29	3	Nut-Lock
19	49-6250	1	Bracket-Pivot
20	3254-6	2	Washer-Lock, Int.
21	3211-2	2	Screw-HH
22	49-6260	1	Pivot ASM
22:2	256-2	2	Bushing
23	3296-4	2	Nut-Lock, NI
24	74-9110	1	Pad-Pedal, Reverse

Ref. No.	Part No.	Qty.	Description
25	83-0540-01	1	Traction Pedal ASM
26	49-6440-03	1	Pedal-Forward
27	74-9100	1	Pad-Pedal, Forward
28	32121-45	1	Pin-Spring
29	256-155	2	Bushing-Flange
30	32128-20	1	Nut-HF
31	2411-42	1	Joint-Ball, LH
32	83-0630	1	Arm-Pivot, Traction
33	3220-20	1	Nut-Jam
34	83-0580	1	Rod-Control, Traction
35	17-9420	1	Screw - Handle
36	2411-43	1	Joint-Ball
37	322-5	2	Screw-HH
38	12-3270	1	Screw
39	49-6290	1	Pivot Shaft ASM
40	32121-51	1	Pin-Roll
41	93-9936	1	Bracket-Return, Traction
42	93-9937	1	Traction Cable ASM
43	283-62	1	Pin-Clevis
44	3272-10	1	Pin-Cotter
45	3217-6	1	Nut-Hex

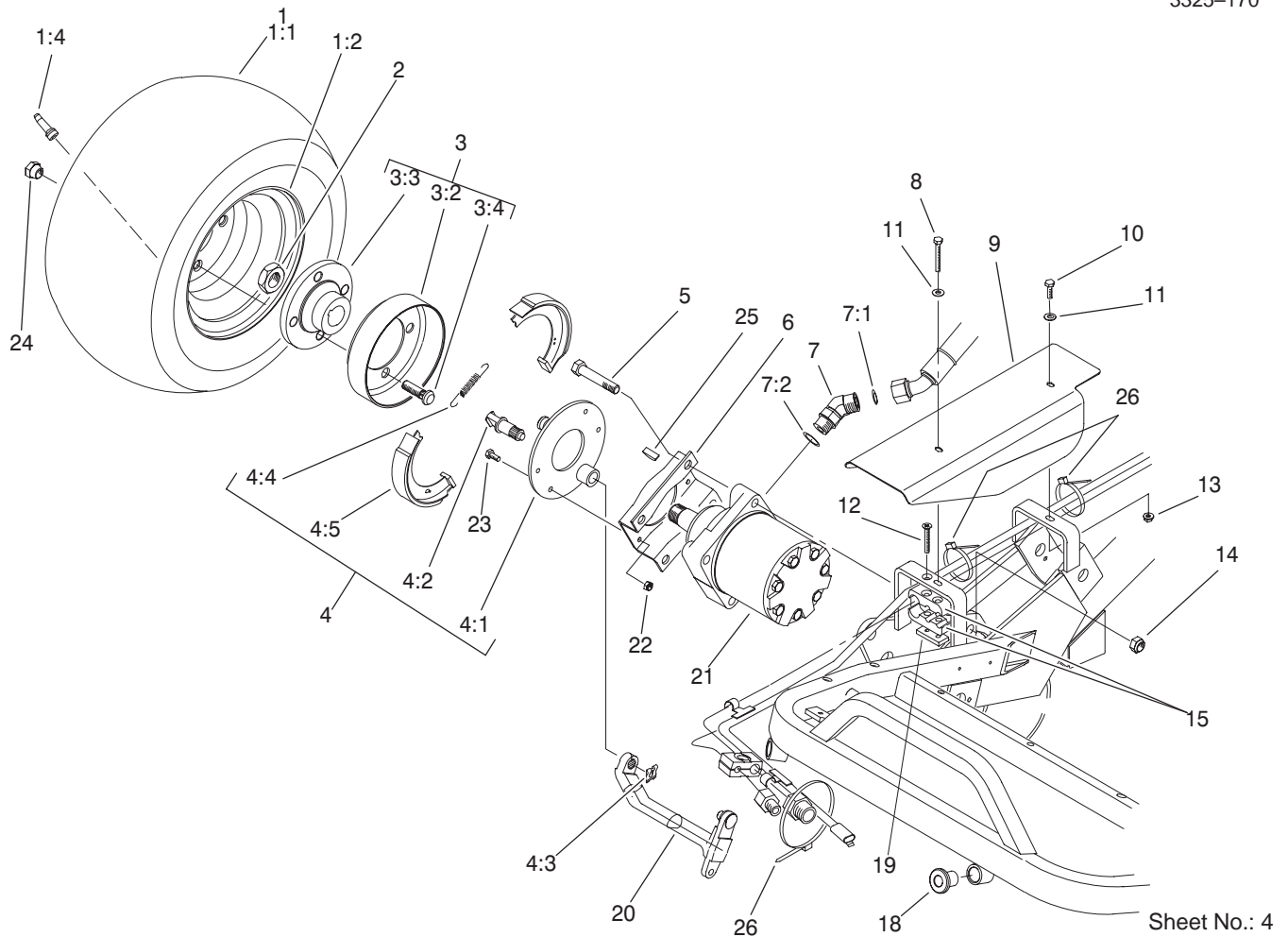

Sheet No.: 4

Front Wheel and Brake Assembly

Ref. No.	Part No.	Qty.	Description
1		2	Wheel & Tire ASM
1:1	28-3680	1	Tire
1:2	217-60	1	Rim
1:4	232-24	1	Stem-Valve
*1:5	232-37	1	Tube
2	26-3790	2	Nut-Lock
3	10-6821	2	Brake Drum ASM
3:2	10-6850	1	Drum-Brake
3:3	10-6870-03	1	Hub-Wheel
3:4	85-6540	4	Stud-Drive
4	71-1500	2	Brake ASM
4:1	70-9870	1	Plate-Backing
4:2	70-9860	1	Cam-Brake
4:3	70-9850	1	Clip-Retaining
4:4	70-9880	2	Spring-Return
4:5	70-9840	2	Shoe-Brake
5	325-11	8	Screw-HH
6	84-2000-03	2	Bracket-Brake
7	340-14	4	Fitting-Hyd., 45°
7:1	237-65	1	O-Ring
7:2	237-80	1	O-Ring
8	321-11	1	Screw-HH
9	83-0190-01	1	Cover-RH
10	321-4	1	Screw-HH
11	3256-22	2	Washer-Flat
12	32108-100	1	Screw-FH

Ref. No.	Part No.	Qty.	Description
13	32128-33	1	Nut-HF
14	3296-23	8	Nut-Lock, NI
15	57-6140	2	Clamp-Tube, Half
18	83-1700	2	Bushing - Flange
19	83-1220	1	Plate-Clamp
20	93-2096	2	Lever - Brake
21	92-9199	2	Motor-Hydraulic
22	3296-42	8	Nut-Lock
23	321-5	8	Screw-HH
24	242-50	8	Nut - Lug
25	3257-42	2	Key-Woodruff
26	3290-378	3	Tie-Cable

* Not illustrated

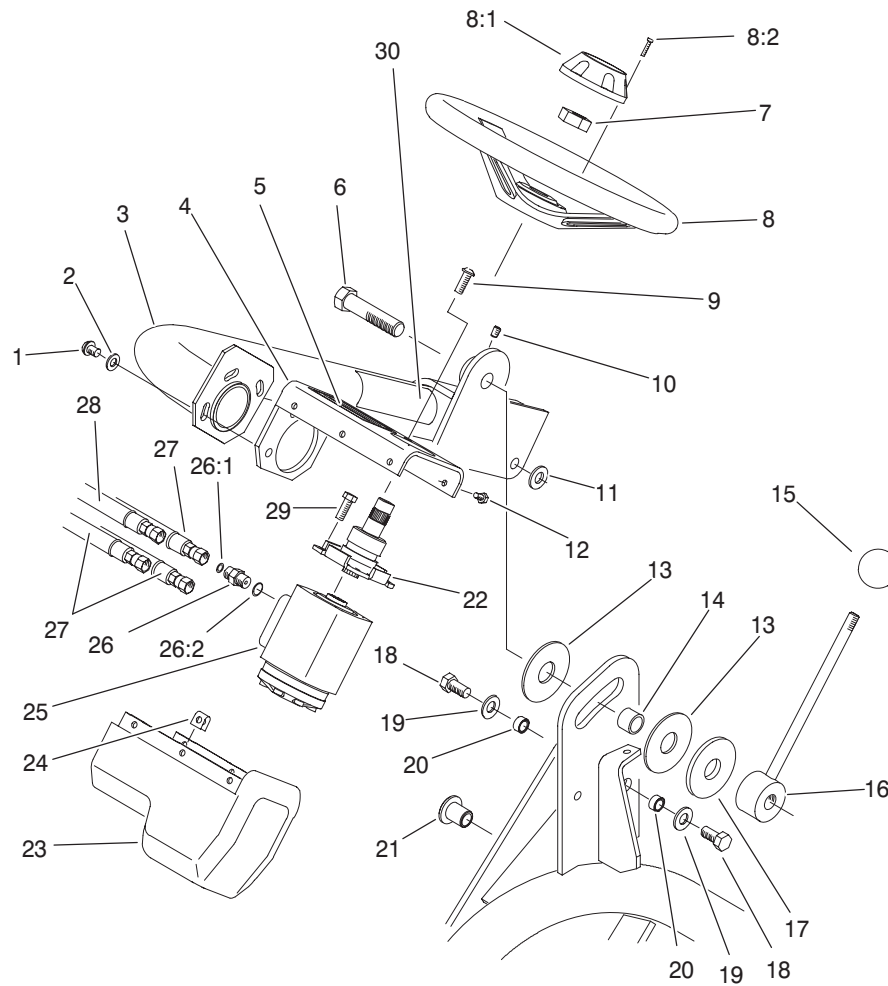

Sheet No.: 5

Steering Arm Assembly

Ref. No.	Part No.	Qty.	Description
1	3274-80	3	Screw-HH
2	3256-80	3	Washer-Flat
3	83-0650-01	1	Arm-Steering
4	83-0780-03	1	Support-Valve, Steering
5	93-8063	1	Decal-Warning (Int'l)
5	104-2053	1	Decal Warning
6	83-0750	1	Capscrew-HH, LH Thread
7	47-6990	1	Nut
8	68-5130	1	Wheel-Steering
8:1	68-5140	1	Cap-Wheel, Steering
8:2	32144-21	1	Screw
9	3274-63	2	Screw-HSH
10	3246-3	1	Screw-HS
11	65-6390	1	Washer - Thrust, Plain
12	3274-39	6	Screw-HSBH
13	83-0740	2	Disc - Friction
14	83-0730	1	Spacer-Lockup
15	233-48	1	Knob
16	83-0700-03	1	Handle-Lockup
17	83-0760	1	Spacer-Plate, Lockup
18	325-4	2	Screw-HH
19	3256-26	2	Washer-Flat
20	47-2890	2	Bushing
21	83-1700	1	Bushing - Flange

Ref. No.	Part No.	Qty.	Description
22	83-1420	1	Column-Steering
23	83-0810	1	Cover - Steering
24	3290-277	6	Nut-Speed
25	92-8690	1	Valve-Control, Steering
26	340-1	4	Adapter
26:1	237-35	1	O-Ring
26:2	237-42	1	O-Ring
27	83-1350	3	Hose-Hydraulic
28	83-1360	1	Hose-Hydraulic
29	323-4	2	Screw-HH
30	93-8068	1	Decal-Arm, Steering

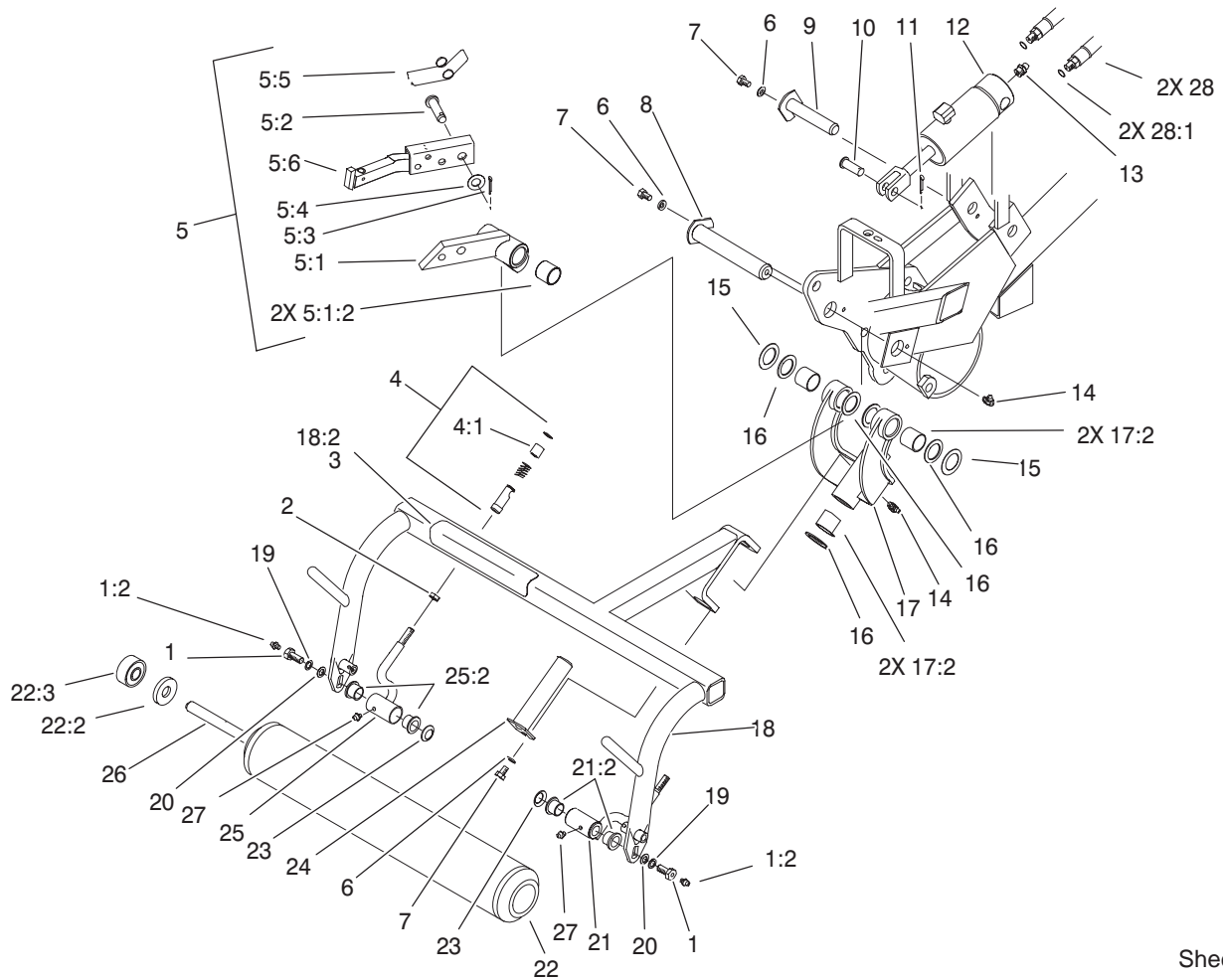

Sheet No.: 6

RH Pull Frame Assembly

Ref. No.	Part No.	Qty.	Description
1	11-0160	2	Roller Shaft Screw ASM
1:2	302-5	1	Fitting - Grease
2	3220-3	2	Nut-Jam
3	93-8064	1	Decal-Danger (Int'l)
4	99-1460	2	Ball Joint Receiver ASM
4:1	99-1461	1	Sleeve-Joint, Ball
5		1	RH Lift Arm ASM
5:1	62-2440	1	Lift Arm ASM
5:1:2	3-0348	2	Bushing
5:2	63-8750	1	Pin-Pivot
5:3	3272-11	1	Pin-Cotter
5:4	3256-26	1	Washer-Flat
5:5	57-7650	1	Spring-Torsion
5:6	94-5588-01	1	Bar-Lift, R/H
6	3256-23	3	Washer-Flat
7	322-1	3	Screw-HH
8	10-6110	1	Pin-Hinge
9	10-6060	1	Pin-Pivot, Ram
10	283-8	1	Pin-Clevis
11	3272-11	1	Pin-Cotter
12	99-8159	1	Hydraulic Cylinder ASM
13	302-2	1	Fitting-Grease
14	302-60	2	Fitting-Lube

Ref. No.	Part No.	Qty.	Description
15	5-1226	2	Washer
16	10-8110	6	Washer-Thrust
17	10-7820	1	Pivot Hinge ASM
17:2	3-0348	4	Bushing
18	104-2055	1	Right Pull Frame ASM
18:2	62-5070	1	Warning Decal
19	3253-21	2	Washer-Lock
20	3256-24	2	Washer-Flat
21	92-0586	1	Pull Arm ASM
21:2	3-1506	2	Bushing
22	99-4277	1	Roller ASM
22:2	253-83	1	Seal-Oil
22:3	251-141	2	Bearing-Ball
23	3290-317	2	Washer-Spring
24	10-6090	1	Pin-Pivot
25	92-0585	1	Pull Arm ASM
25:2	3-1506	2	Bushing
26	21-8470	1	Shaft-Roller
27	302-5	2	Fitting - Grease
28	92-9767	2	Hose
28:1	237-78	1	O-Ring

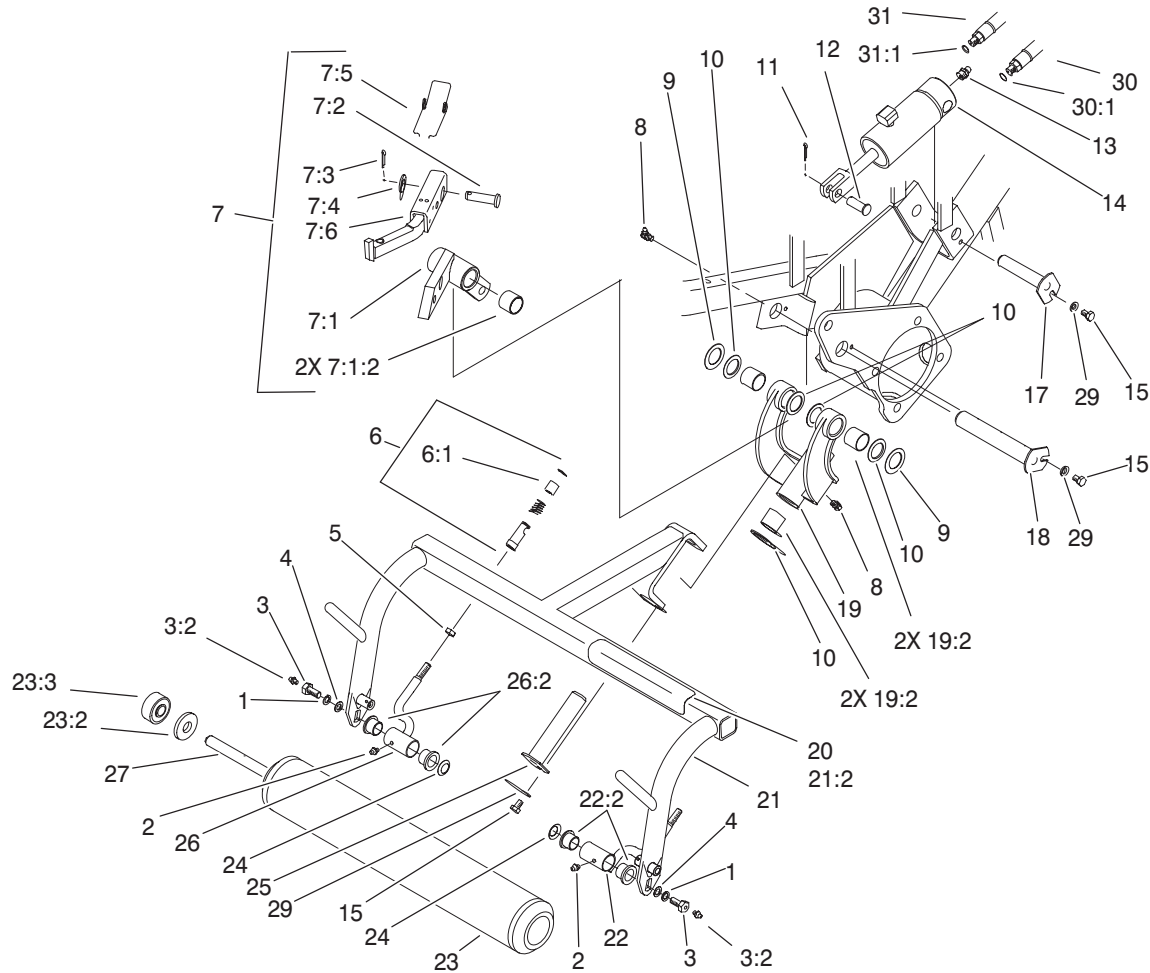

Sheet No.: 7

LH Pull Frame Assembly

Ref. No.	Part No.	Qty.	Description
1	3253-21	2	Washer-Lock
2	302-5	2	Fitting - Grease
3	11-0160	2	Roller Shaft Screw
3:2	302-5	1	Fitting - Grease
4	3256-24	2	Washer-Flat
5	3220-3	2	Nut-Jam
6	99-1460	2	Ball Joint Receiver
6:1	99-1461	1	Sleeve-Joint, Ball
7		1	LH Lift Arm ASM
7:1	62-2460	1	Lift Arm ASM
7:1:2	3-0348	2	Bushing
7:2	63-8750	1	Pin-Pivot
7:3	3272-11	1	Pin-Cotter
7:4	3256-26	1	Washer-Flat
7:5	57-7650	1	Spring-Torsion
7:6	94-5586-01	1	Bar-Lift, LH
8	302-60	2	Fitting-Lube
9	5-1226	2	Washer
10	10-8110	6	Washer-Thrust
11	3272-11	1	Pin-Cotter
12	283-8	1	Pin-Clevis
13	302-2	1	Fitting-Grease
14	99-8159	1	Hydraulic Cylinder

Ref. No.	Part No.	Qty.	Description
15	322-1	3	Screw-HH
17	10-6060	1	Pin-Pivot, Ram
18	10-6110	1	Pin-Hinge
19	10-7820	1	Pivot Hinge ASM
19:2	3-0348	4	Bushing
20	93-8064	1	Decal-Danger (Int'l)
21	104-2054	1	Left Pull Frame ASM
21:2	62-5070	1	Warning Decal
22	92-0586	1	Pull Arm ASM
22:2	3-1506	2	Bushing
23	99-4277	1	Roller ASM
23:2	253-83	1	Seal-Oil
23:3	251-141	2	Bearing-Ball
24	3290-317	2	Washer-Spring
25	10-6090	1	Pin-Pivot
26	92-0585	1	Pull Arm ASM
26:2	3-1506	2	Bushing
27	21-8470	1	Shaft-Roller
29	3256-23	3	Washer-Flat
30	83-1690	1	Hose-Hydraulic
30:1	237-78	1	O-Ring
31	63-3850	1	Hose ASM
31:1	237-78	1	O-Ring

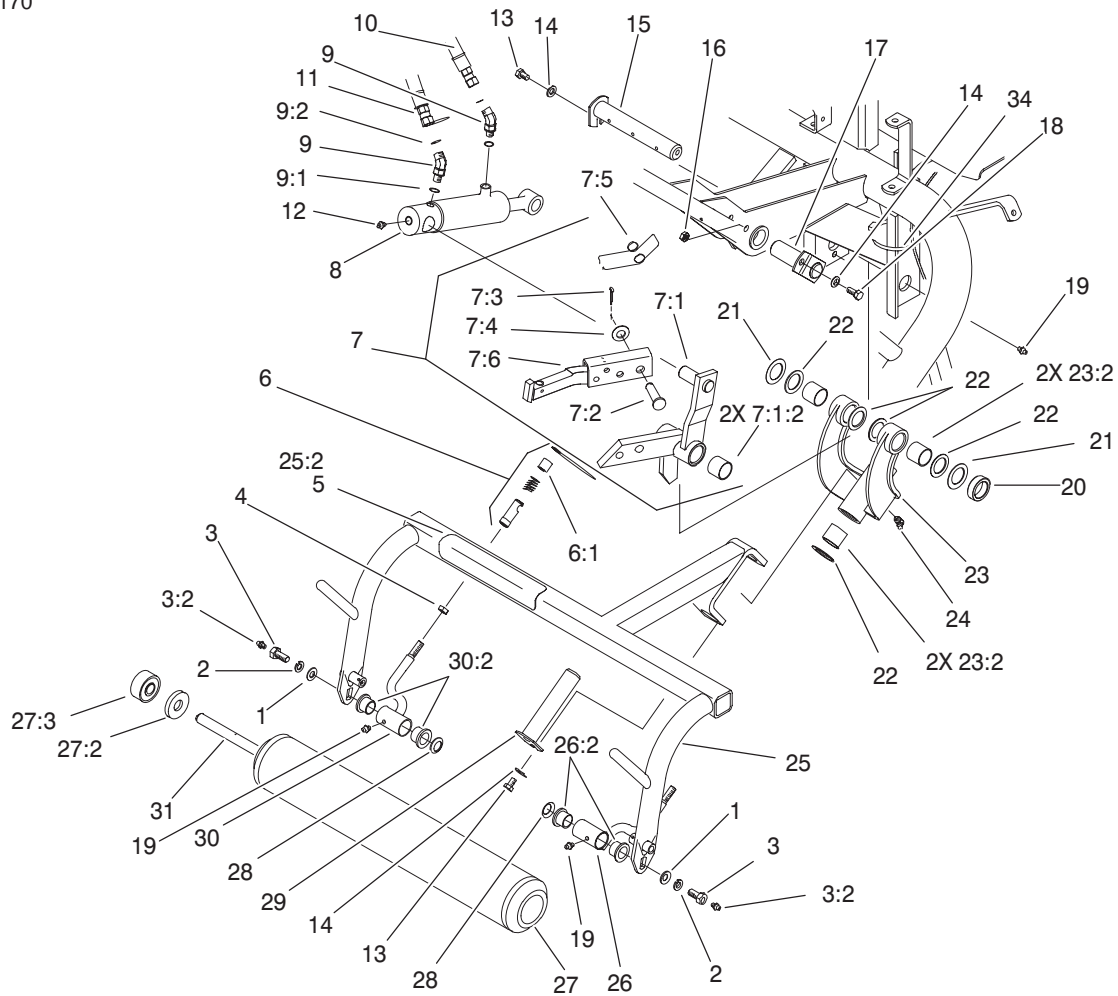

Sheet No.: 8

Rear Pull Frame Assembly

Ref. No.	Part No.	Qty.	Description
1	3256-24	2	Washer-Flat
2	3253-21	2	Washer-Lock
3	11-0160	2	Roller Shaft Screw
3:2	302-5	1	Fitting - Grease
4	3220-3	2	Nut-Jam
5	93-8064	1	Decal-Danger (Int'l)
6	99-1460	2	Ball Joint Receiver
6:1	99-1461	1	Sleeve-Joint, Ball
7		1	Center Lift Arm ASM
7:1	68-5380	1	Center Lift Arm ASM
7:1:2	3-0348	2	Bushing
7:2	63-8750	1	Pin-Pivot
7:3	3272-11	1	Pin-Cotter
7:4	3256-26	1	Washer-Flat
7:5	57-7650	1	Spring-Torsion
7:6	62-2420-01	1	Bar-Lift
8	99-8160	1	Hydraulic Cylinder
9	340-103	2	Fitting
9:1	237-78	1	O-Ring
9:2	237-21	1	O-Ring
10	83-1680	1	Hose-Hydraulic
11	88-9700	1	Hose-Hydraulic
12	302-2	1	Fitting-Grease

Ref. No.	Part No.	Qty.	Description
13	322-1	2	Screw-HH
14	3256-23	3	Washer-Flat
15	27-2550	1	Pin-Hinge
16	3296-29	1	Nut-Lock
17	68-5560	1	Pin-Cylinder, Pivot
18	322-3	1	Screw-HH
19	302-5	3	Fitting - Grease
20	93-2384	1	Spacer-Carrier
21	5-1226	2	Washer
22	10-8110	6	Washer-Thrust
23	10-7820	1	Pivot Hinge ASM
23:2	3-0348	4	Bushing
24	302-60	1	Fitting-Lube
25	104-2056	1	Rear Pull Frame ASM
25:2	62-5070	1	Warning Decal
26	92-0586	1	Pull Arm ASM
26:2	3-1506	2	Bushing
27	99-4277	1	Roller ASM
27:2	253-83	1	Seal-Oil
27:3	251-141	2	Bearing-Ball
28	3290-317	2	Washer-Spring
29	10-6090	1	Pin-Pivot
30	92-0585	1	Pull Arm ASM
30:2	3-1506	2	Bushing
31	21-8470	1	Shaft-Roller
34	3290-379	1	Tie-Cable

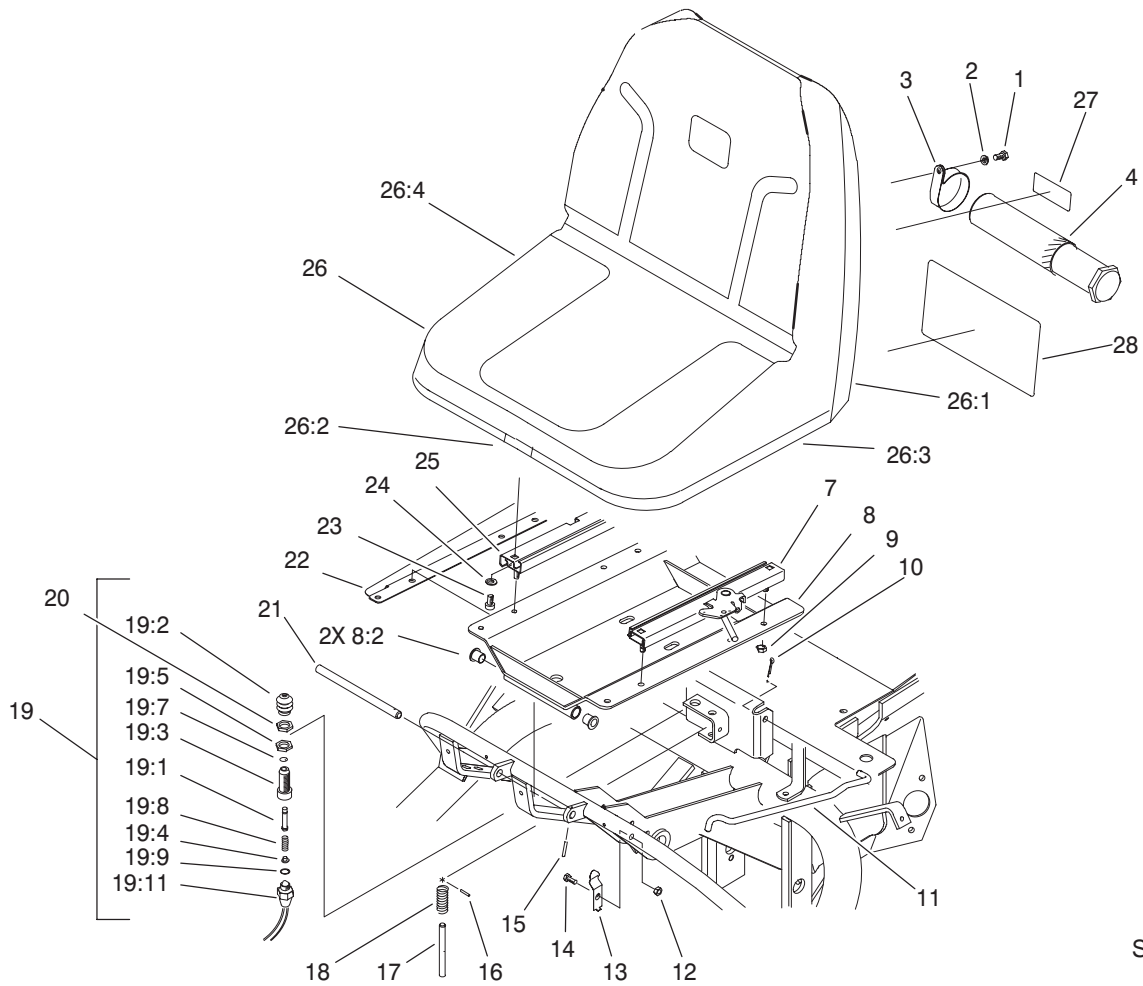

Sheet No.: 9

Seat Assembly

Ref. No.	Part No.	Qty.	Description
1	322-2	2	Screw-HH
2	3253-4	2	Washer
3	2412-133	2	R-Clamp
4	74-0720	1	Tube-Manual
7	51-0790	1	Adjuster-Seat, LH
8	83-1270	1	Seat Support ASM
8:2	256-155	2	Bushing-Flange
9	3296-29	4	Nut-Lock
10	3272-11	1	Pin-Cotter
11	68-5100	1	Rod-Seat, Prop
12	3296-16	1	Nut-Lock, NI
13	68-5310	1	Clip-Rod, Prop
14	321-3	1	Screw-HH
15	32121-45	1	Pin-Spring
16	3284-3	1	Pin-Groove
17	51-0350	1	Pin-Spring, Seat
18	3-6685	1	Spring
19	43-9071	1	Limit Switch ASM
19:1	43-8860	1	Plunger-Switch
19:2	43-8870	1	Switch Boot
19:3	43-8620	1	Pin - Guide, Switch
19:4	43-8610	1	Guide
19:5	218-461	1	Nut-HH
19:7	237-7	1	O-Ring
19:8	43-8600	1	Spring-Compression
19:9	237-30	1	O-Ring

Ref. No.	Part No.	Qty.	Description
19:11	72-4320	1	Switch
20	218-461	1	Nut-HH
21	49-5880	1	Shaft-Support, Seat
22	83-1840-01	1	Cover-Valve, RH
23	3274-12	4	Screw-HSH
24	3256-23	4	Washer-Flat
25	51-0780	1	Slider-Seat
26	100-3187	1	Seat ASM
26:1	92-6534	1	Shell
26:2	351-80	1	Clip
26:3	351-78	1	Edging
26:4	100-6411	1	Cushion-Replacement
27	93-8067	1	Decal-Oil, Hydraulic
*28	93-7260	1	Decal-Service, Danish
*28	84-9250	1	Decal-Service, French
28	94-8036	1	Decal - Service
*28	93-7261	1	Decal-Service, Dutch
*28	83-2490	1	Decal-Service, Japanese
*28	84-9240	1	Decal-Service, Spanish
*28	84-9260	1	Decal-Service, German
*28	84-9270	1	Decal-Service, Swedish
*28	84-9280	1	Decal-Service, Italian

* Not illustrated

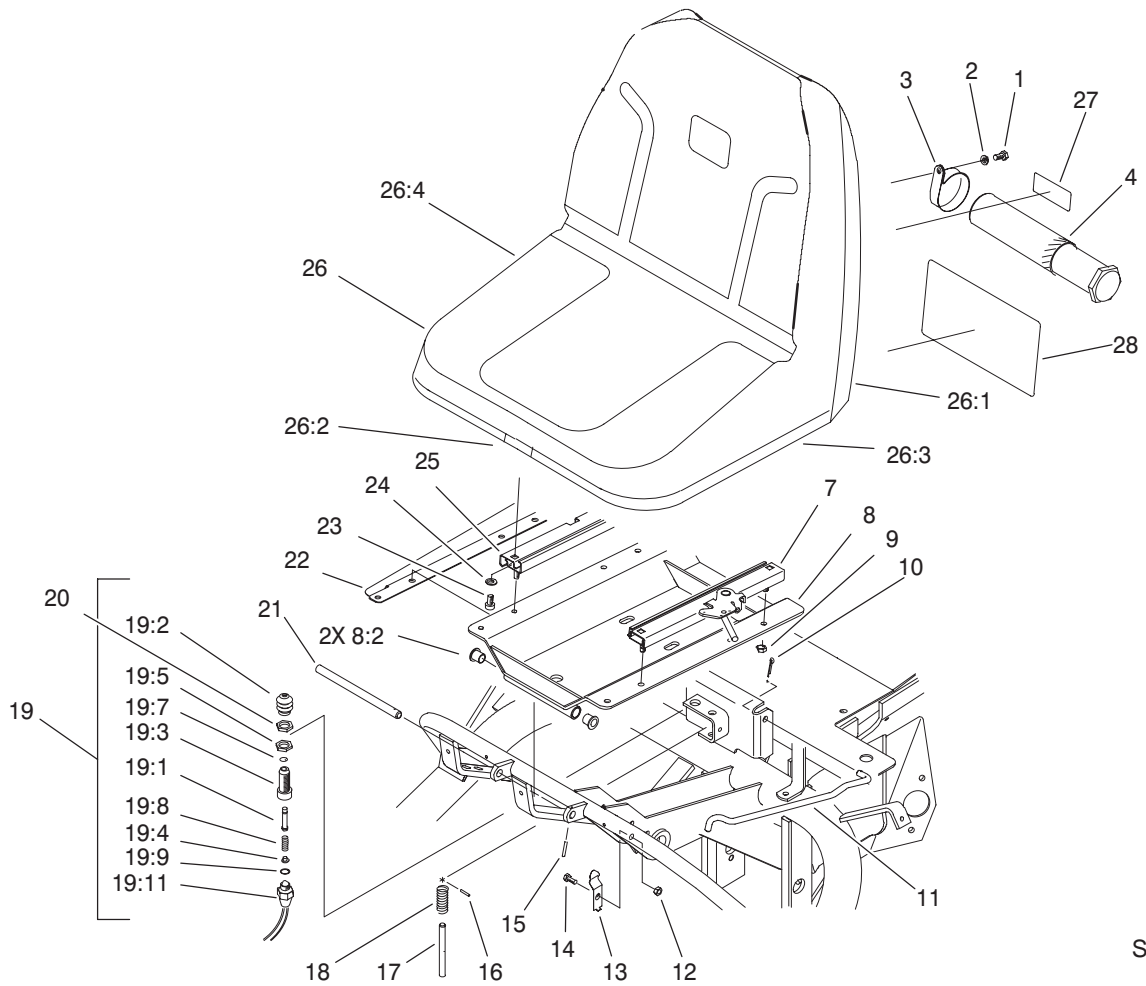

Sheet No.: 9

Seat Assembly (Continued)

Ref. No.	Part No.	Qty.	Description
*28	93-7257	1	Decal-Service, Portugese
*28	93-7258	1	Decal-Service, Norwegian
*28	93-7259	1	Decal-Service, Finnish

Ref. No.	Part No.	Qty.	Description

* Not illustrated

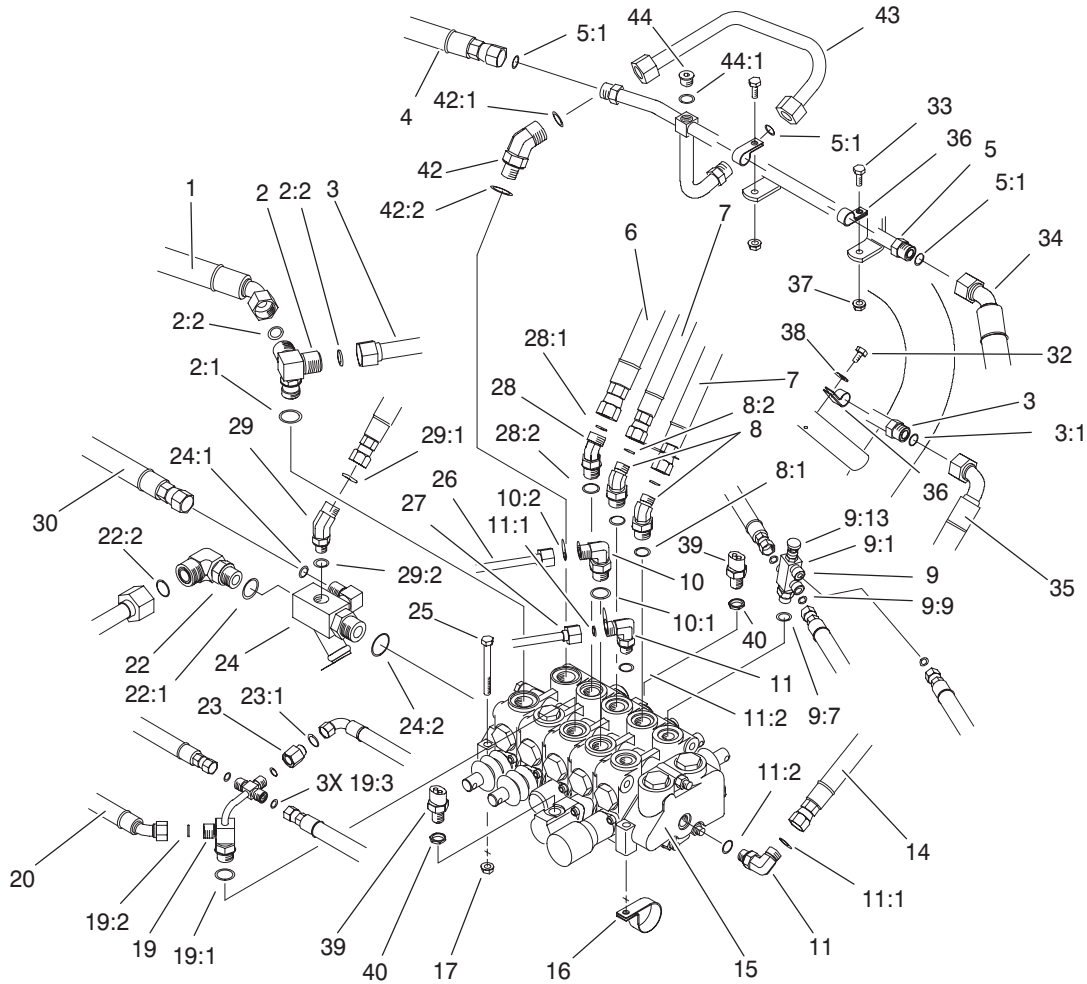

Sheet No.: 10

Control Valve Installation Assembly

Ref. No.	Part No.	Qty.	Description
1	98-0647	1	Hose-Hydraulic
2	63-4050	1	Fitting
2:1	237-80	1	O-Ring
2:2	237-65	2	O-Ring
3	70-7130	1	Line-Tube
3:1	237-65	2	O-Ring
4	98-2152	1	Hydraulic Hose ASM
5	93-0113	1	Tube - Traction
5:1	237-65	3	O-Ring
6	98-2151	1	Hose-Hydraulic
7	98-0649	2	Hose-Hydraulic
8	340-138	2	Fitting
8:1	237-79	1	O-Ring
8:2	237-22	1	O-Ring
9	93-2556	1	Needle Valve ASM
9:1	93-2555	1	Fitting - Body
9:7	237-42	1	O-Ring
9:9	237-21	3	O-Ring
9:13	93-2554	1	Needle ASM
10	340-18	1	Fitting
10:1	237-79	1	O-Ring
10:2	237-22	1	O-Ring
11	340-77	2	Fitting-90°
11:1	237-22	1	O-Ring
11:2	237-42	1	O-Ring
14	98-2150	1	Hose-Hydraulic

Ref. No.	Part No.	Qty.	Description
15	84-2203	1	Valve-Control, 5 Spool
16	304-61	1	Clamp-Hose
17	32128-20	3	Nut-HF
19	83-1670	1	Fitting ASM
19:1	237-79	1	O-Ring
19:2	237-22	1	O-Ring
19:3	237-21	3	O-Ring
20	95-5986	1	Hose-Hydraulic
22	340-16	1	Fitting-Hyd., 90°
22:1	237-80	1	O-Ring
22:2	237-58	1	O-Ring
23	71-0990	1	Orifice
23:1	237-21	1	O-Ring
24	68-5260	1	Manifold-Tee
24:1	237-30	1	O-Ring
24:2	237-81	1	O-Ring
25	322-14	3	Screw-HH
26	63-4030	1	Tube-Hydraulic
27	63-4020	1	Tube-Hydraulic
28	340-101	1	Fitting
28:1	237-30	1	O-Ring
28:2	237-79	1	O-Ring
29	340-137	1	Fitting
29:1	237-21	1	O-Ring
29:2	237-42	1	O-Ring
30	95-5987	1	Hose-Hydraulic

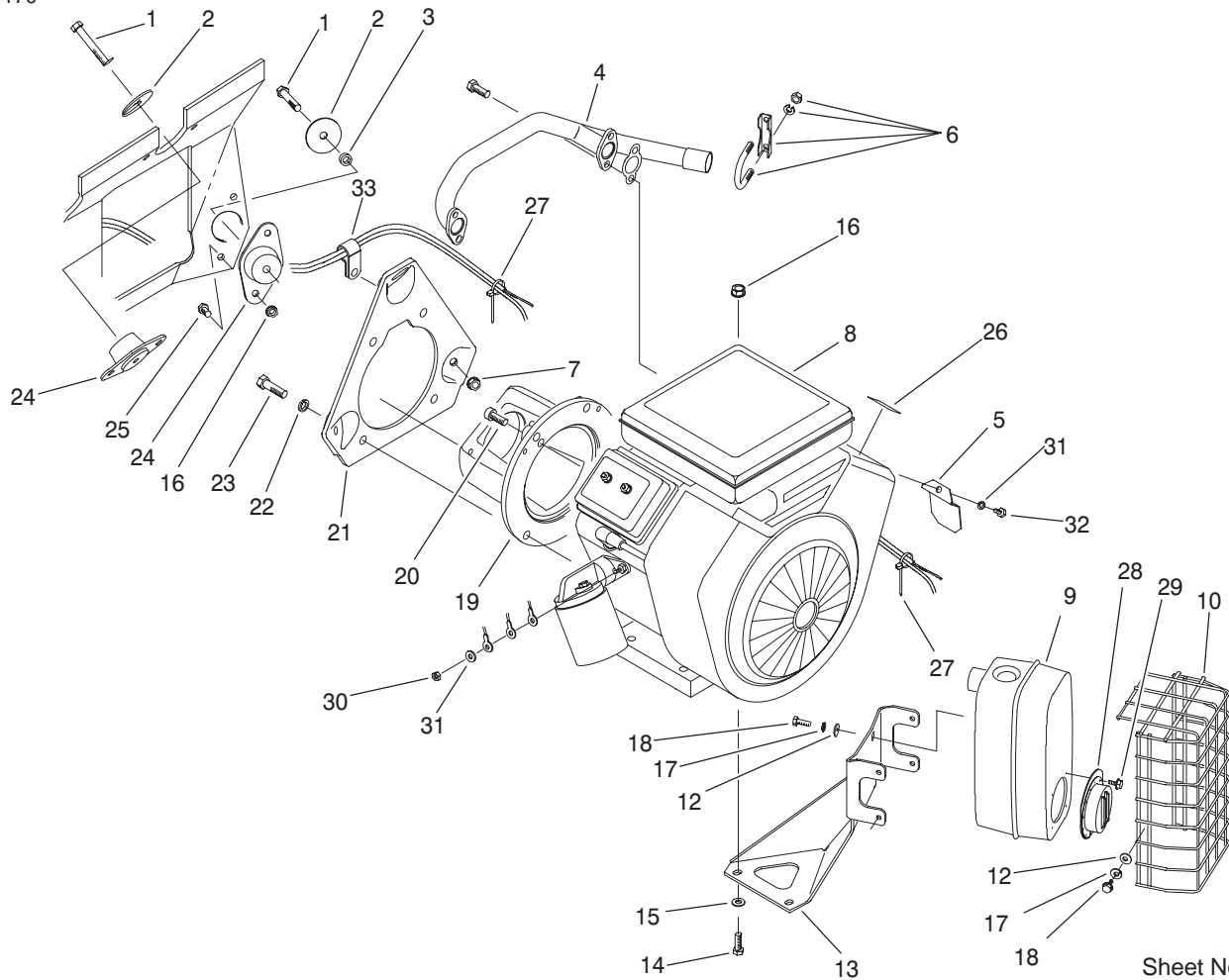

Sheet No.: 11

Engine Installation Assembly

Ref. No.	Part No.	Qty.	Description
1	323-12	3	Screw-HH
2	83-1040	3	Washer - Flat
3	83-1050	2	Spacer
4	83-1080	1	Exhaust Manifold ASM
5	83-2310	1	Shield - Regulator
6	2112-11	1	Clamp-Muffler
7	3290-357	3	Nut-Flange, Lock
8	100-6438	1	Engine-18 HP
9	98-0616	1	Muffler ASM
10	83-1400-03	1	Shield-Muffler
12	3256-1	8	Washer-Flat
13	83-1630-03	1	Bracket-Support, Muffler
14	322-8	2	Screw-HH
15	3256-23	2	Washer-Flat
16	32128-20	8	Nut-HF
17	3253-3	8	Washer-Lock/Sp
18	49-2040	8	Screw - Tapping
19	83-1060-03	1	Adapter-Pump
20	3274-7	2	Screw-HSH
21	85-8120-03	1	Plate-Mount, Engine
22	3253-6	4	Washer-Lock/Sp
23	324-7	4	Screw-HH
24	83-1030	3	Mount-Engine
25	322-3	6	Screw-HH
26	93-8069	1	Decal-Surface, Hot

Ref. No.	Part No.	Qty.	Description
27	3290-379	2	Tie-Cable
28	83-2220	1	Deflector-Exhaust
29	83-2230	4	Screw-HH
30	43-2830	1	Nut-Hex
31	43-5930	2	Washer-Spring
32	33113-016	1	Screw-HH
33	2412-81	1	Clamp

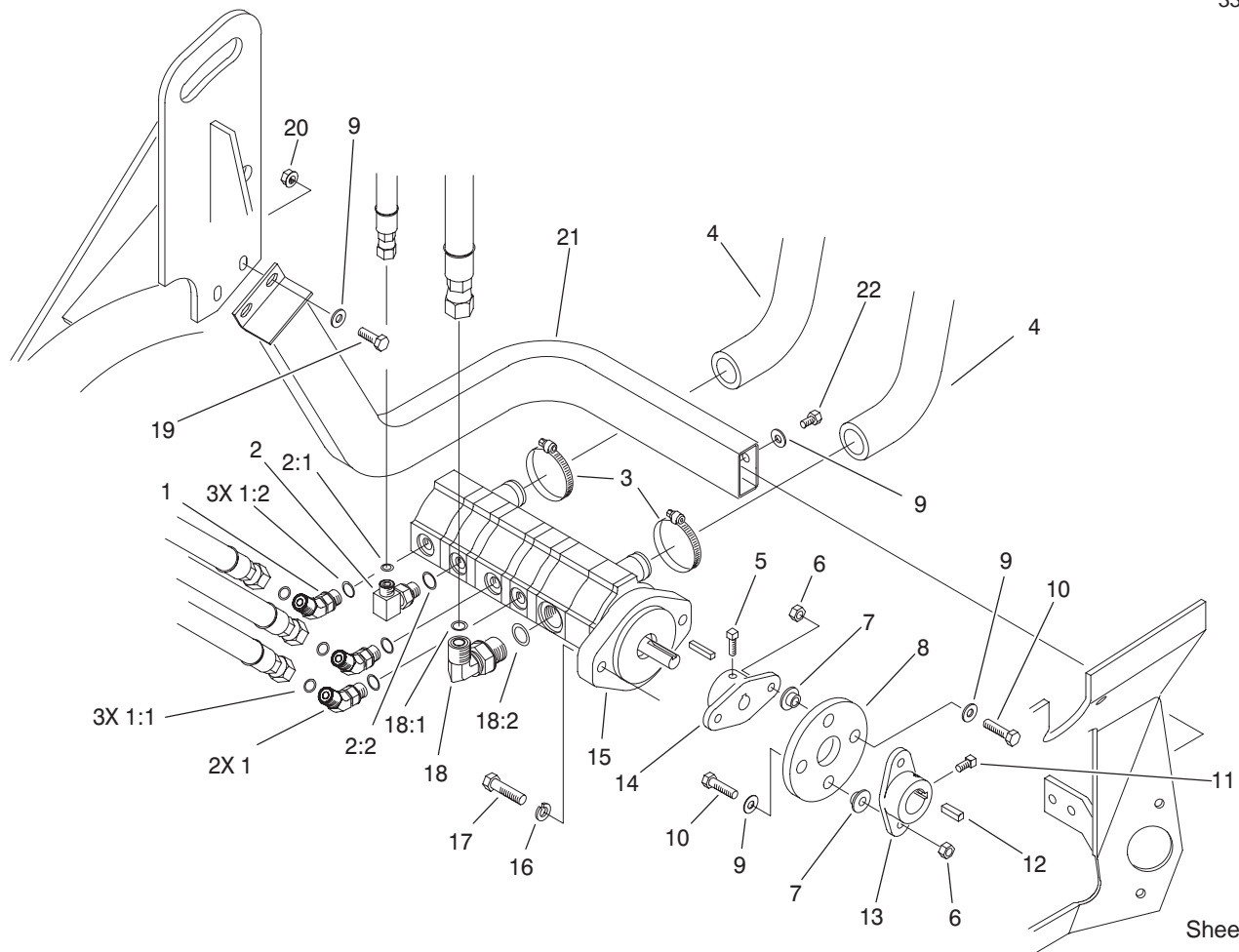

Sheet No.: 12

Hydraulic Pump Installation Assembly

Ref. No.	Part No.	Qty.	Description
1	340-87	3	Fitting-45°
1:1	237-22	1	O-Ring
1:2	237-42	1	O-Ring
2	340-82	1	Adapter
2:1	237-42	1	O-Ring
2:2	237-21	1	O-Ring
3	2412-34	2	Clamp-Hose
4	83-0910	2	Hose-Inlet, Pump
5	3241-6	2	Screw-SQH
6	3296-29	4	Nut-Lock
7	27-6600	4	Spacer-Coupling, Rubber
8	44-2230	1	Coupling-Rubber
9	3256-23	8	Washer-Flat
10	322-6	4	Screw-HH
11	3241-2	2	Screw-SQH
12	10-7070	1	Key-Square
13	27-1960	1	Hub-Engine
14	27-1970	1	Hub-Pump
15	92-9764	1	Hydraulic Pump ASM
16	3253-21	2	Washer-Lock
17	323-8	2	Screw-HH
18	340-105	1	Fitting-90°
18:1	237-80	1	O-Ring
18:2	237-30	1	O-Ring
19	322-4	2	Screw-HH

Ref. No.	Part No.	Qty.	Description
20	32128-20	2	Nut-HF
21	83-1940-01	1	Guard-Pump
22	322-1	2	Screw-HH

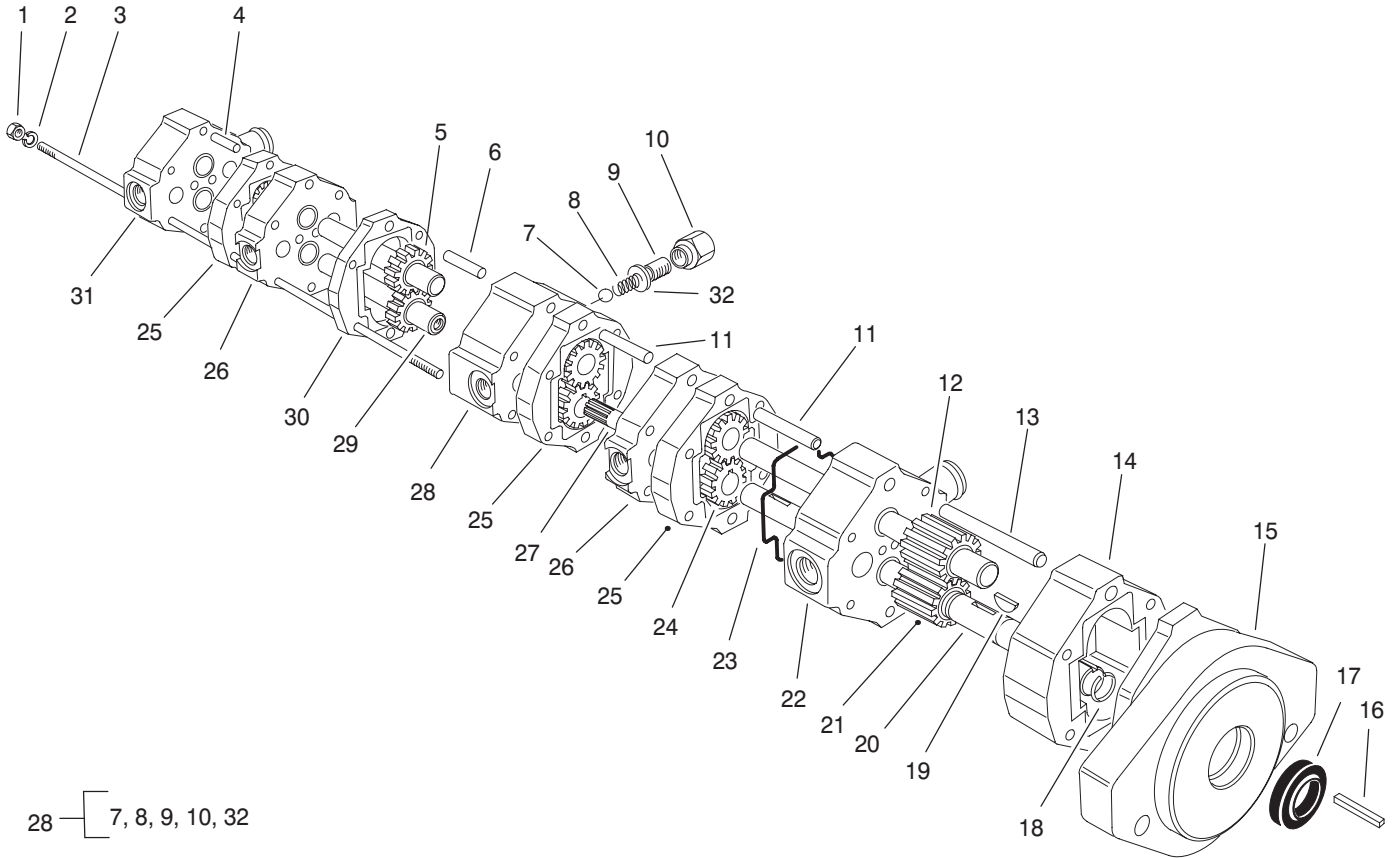

28 — [7, 8, 9, 10, 32

Note: Parts Not Listed
In Parts List Are Not
Serviced Separately .

Sheet No.: A5
T-0645

Hydraulic Pump 92-9764

Ref. No.	Part No.	Qty.	Description
1	3217-6	4	Nut-Hex
2	354-16	4	Washer
3	354-17	4	Stud
4	354-11	2	Dowel
5	354-9	1	Idler Shaft & Gear ASM
6	354-12	2	Dowel
11	354-13	4	Dowel
12	92-9774	1	Shaft
13	354-14	2	Pin-Dowel
14	92-9766	1	Plate-Gear
15	354-2	1	Body ASM
16	5-0946	1	Key-Square
17	354-15	1	Seal-Oil
18	353-886	2	Ring-Retaining
19	353-884	4	Key
20	92-9772	1	Shaft-Drive
21	92-9773	1	Gear - 59b
22	354-3	1	Bearing Plate ASM
23	353-922	10	Ring-Seal
24	353-967	6	Gear
25	353-969	3	Plate-Gear
26	353-923	2	Plate
27	354-5	1	Adaptor-Splined
28	354-4	1	Bearing Plate ASM

Ref. No.	Part No.	Qty.	Description
29	354-8	1	Drive Shaft & Gear ASM
30	354-6	1	Plate-Gear
31	354-7	1	Pump Cover ASM
32	354-35	1	Gasket

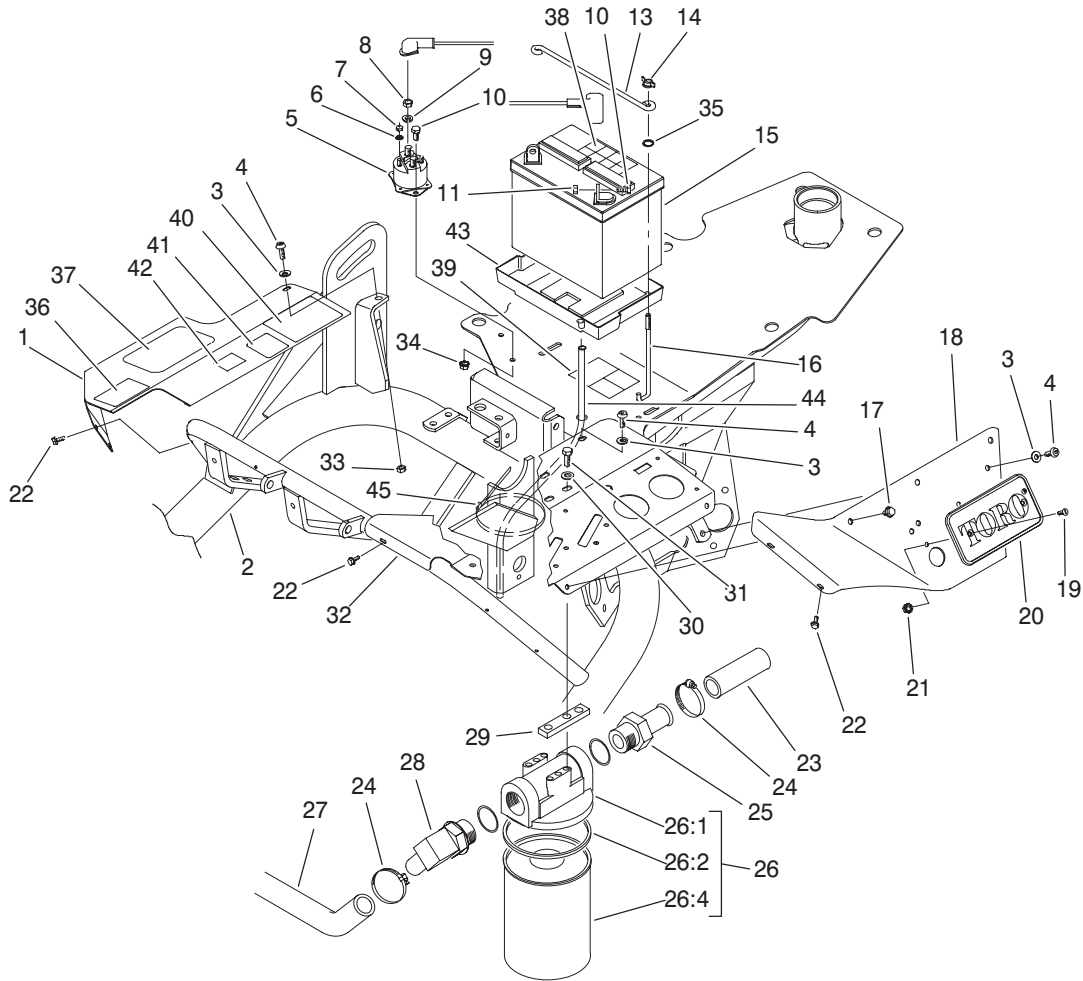

Sheet No.: 13

Frame Assembly

Ref. No.	Part No.	Qty.	Description
1	94-2694-01	1	Cover-RH
2	92-9164-01	1	Frame ASM
3	3256-22	3	Washer-Flat
4	3274-69	3	Screw-HSBH
5	28-4210	1	Solenoid
6	3254-1	2	Washer-Lock/Int
7	3219-14	2	Nut-Hex
8	3218-13	2	Nut-Jam
9	3253-4	2	Washer
10	321-3	4	Screw-HH
11	3217-5	2	Nut-Hex
13	100-6434	1	Hold Down-Battery
14	32103-22	2	Nut-Wing
15	92-1677	1	Battery-Dry
16	100-6435	2	Post-Battery
17	46-8560	3	Screw-HHF
18	83-0840-01	1	Shield-Cover, Valve
19	3290-470	2	Screw-HSFH
20	61-3310	1	Plate-Logo
21	32149-7	2	Nut-Keps
22	32104-76	5	Screw-Slot, Acorn
23	83-1430	1	Hose-Line, Return
24	2412-34	3	Clamp-Hose
25	353-563	1	Fitting-Hydraulic, Straight
26		1	Filter & Head ASM

Ref. No.	Part No.	Qty.	Description
26:1	44-5560	1	Head-Filter, Oil
26:2	72-3850	1	Seal-Filter, Oil
26:4	74-3570	1	Filter
27	68-5880	1	Hose-Hydraulic
28	353-564	1	Fitting-90°
29	27-2380	2	Spacer
30	3256-23	4	Washer-Flat
31	322-4	4	Screw-HH
32	83-0830-01	1	Panel-Control, Upper
33	3296-16	3	Nut-Lock, NI
34	32149-2	2	Nut-Keps
35	237-143	2	O-Ring
36	93-8065	1	Decal-Traction
37	67-1300	1	Decal - Toro
38	93-7276	1	Decal-Danger
39	93-6668	1	Decal - Battery
40	92-5524	1	Decal-Rating, Noise
41	63-9920	1	Decal-Level, Noise
42	93-7252	1	Decal-International
43	106948	1	Tray-Battery
44	104-2061	1	Tube-Battery Drain
45	3290-379	1	Tie-Cable

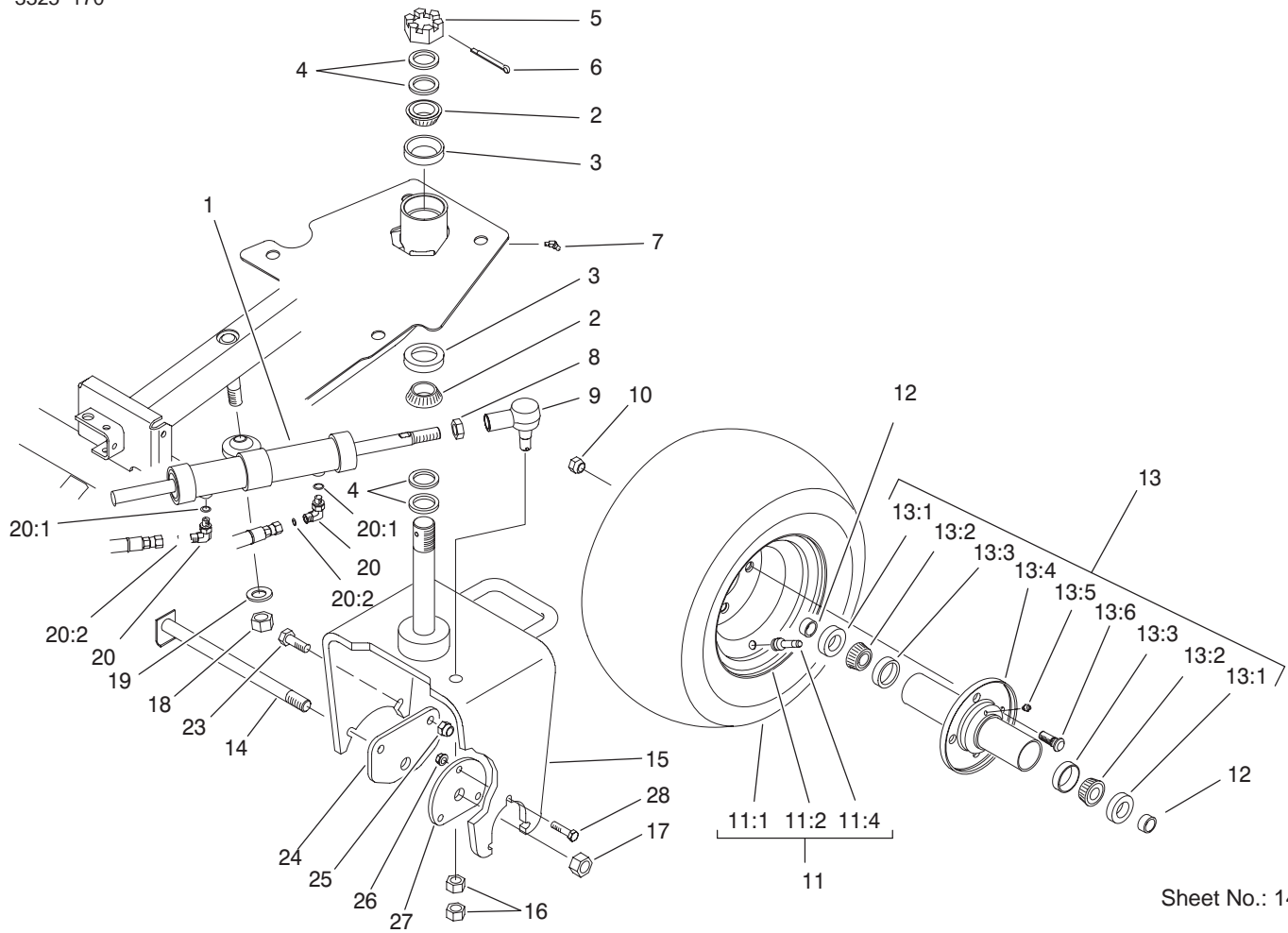

Sheet No.: 14

Rear Wheel Assembly

Ref. No.	Part No.	Qty.	Description
1	83-2330	1	Cylinder – Steering
2	254-70	2	Cone-Bearing
3	254-61	2	Cup-Bearing
4	18-6320	4	Washer-Steering
5	32136-9	1	Nut-Hex, Slot
6	3272-37	1	Pin-Cotter
7	302-11	1	Fitting-Lube, 45°
8	84-5300	1	Nut-Jam
9	83-1640-03	1	Rod End ASM
10	242-50	4	Nut – Lug
11		1	Wheel & Tire ASM
11:1	28-3680	1	Tire
11:2	217-60	1	Rim
11:4	232-24	1	Stem-Valve
*11:5	232-37	1	Tube
12	74-3730	2	Spacer-Spindle, Rear
13		1	Hub-Tire, Sulky
13:1	253-111	2	Seal-Oil
13:2	254-78	2	Cone-Bearing
13:3	254-79	2	Bearing-Roller, Cup
13:4	75-9440	1	Hub ASM
13:5	302-55	1	Zerk
13:6	10-6830	4	Stud-Type, Drive
14	5-3934	1	Bolt-Caster
15	93-2529-01	1	Castor Fork Wa
16	3220-6	2	Nut-Jam

Ref. No.	Part No.	Qty.	Description
17	3296-67	1	Nut-Lock NI
18	3217-12	1	Nut-Hex
19	3256-28	1	Washer-Flat
20	340-132	2	Elbow-90°
20:1	237-78	1	O-Ring
20:2	237-21	1	O-Ring
23	325-6	2	Screw-HH
24	99-1485-01	1	Plate-Adapter, Motor
25	3296-23	2	Nut-Lock, NI
26	3296-39	3	Nut-Lock, NI
27	99-1486-01	1	Plate-Adapter
28	323-8	3	Screw-HH

* Not illustrated

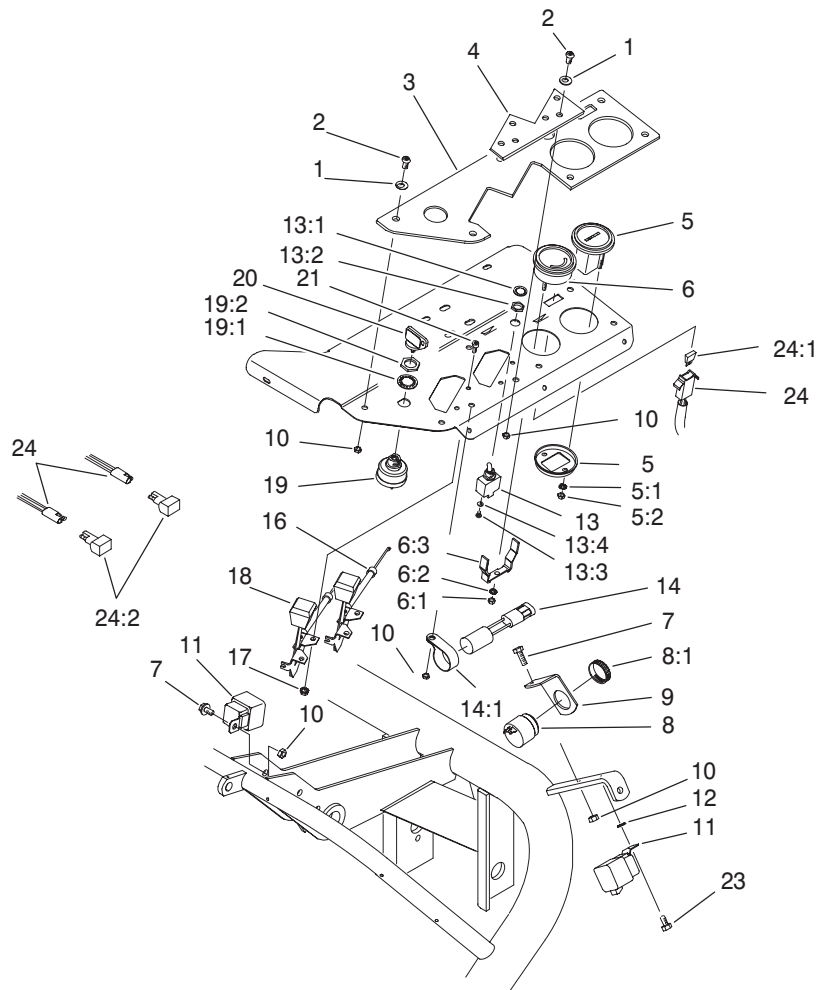

Sheet No.: 15

Control Panel Assembly

Ref. No.	Part No.	Qty.	Description
1	3256-1	8	Washer-Flat
2	3274-69	8	Screw-HSBH
3	93-8061	1	Panel - Control
4	83-2030	1	Plate-Filler
5	66-2950	1	Gauge-Hourmeter
5:1	3255-20	2	Washer-Lock
5:2	3217-25	2	Nut-Hex
6	98-2160	1	Voltmeter
6:1	3217-27	1	Nut-Hex
6:2	3255-25	1	Washer-Lock
6:3	78-0080	1	Clamp-Mounting
7	321-4	2	Screw-HH
8	80-9330	1	Alarm - Audio
8:1	104-5107	1	Nut-Plastic, Knurled
9	83-1530	1	Bracket-Support, Buzzer
10	3296-16	10	Nut-Lock, NI
11	70-1480	2	Relay
12	3255-7	1	Washer-Lock/Ext
13	83-1660	1	Switch - 3 Position
13:1	218-498	2	Locknut-Hex
13:2	218-589	1	Washer
13:3	218-588	3	Screw
13:4	3253-19	3	Washer-Lock/Sp
14	83-2280	1	Timer - Delay
14:1	98-4604	1	Clamp-R

Ref. No.	Part No.	Qty.	Description
16	83-0040	1	Control - Choke
17	3296-27	4	Nut-Lock NI
18	83-0030	1	Control - Throttle
19	88-9830	1	Switch-Ignition
19:1	3254-5	1	Washer-Lock/Internal
19:2	218-461	1	Nut-HH
20	63-8360	2	Key-Ignition
21	3273-26	4	Screw-HSH
23	32104-95	1	Screw-HWH
24	104-2058	1	Harness-Wire, Main
24:1	218-578	1	Fuse-10 Amp
24:2	100-4918	2	Diode

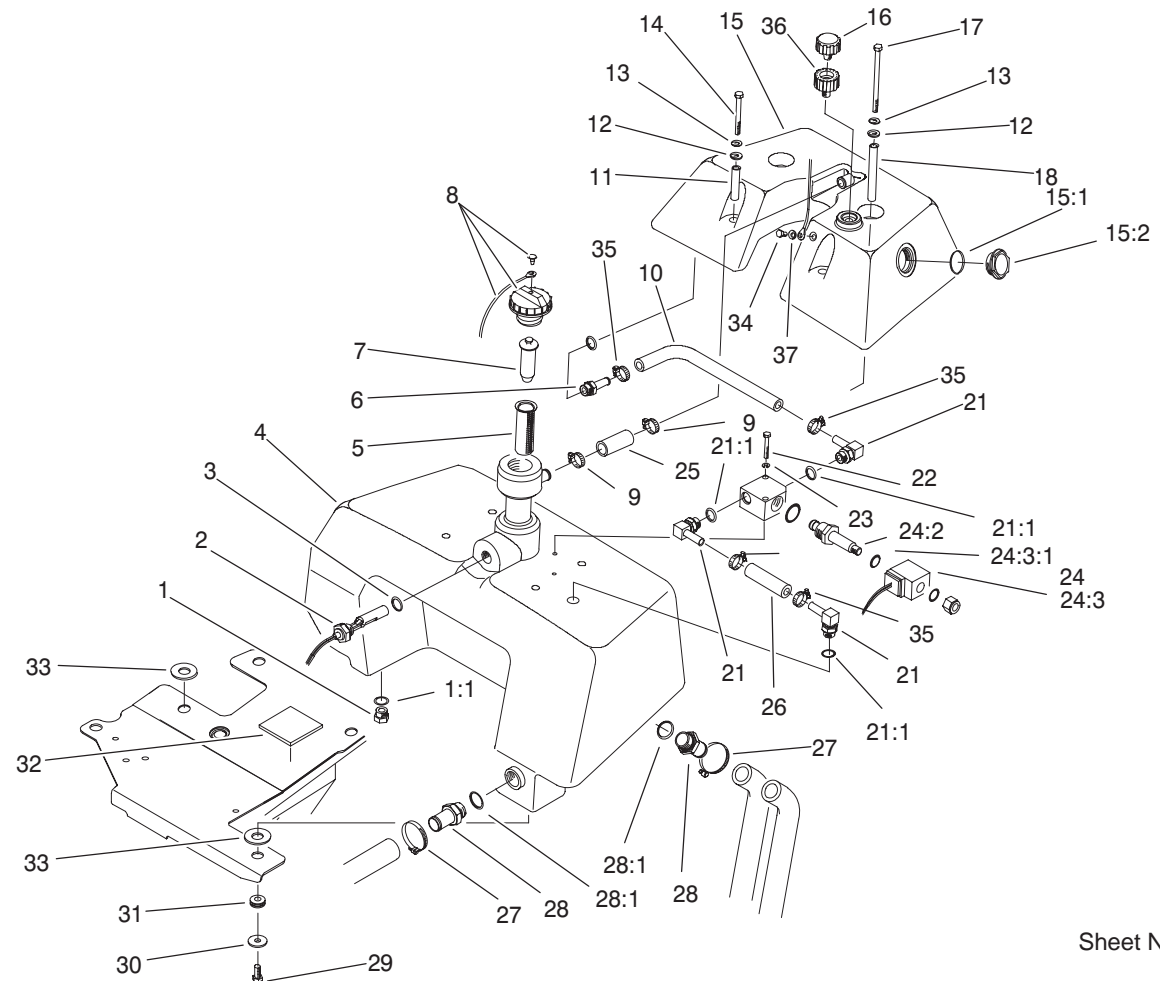

Sheet No.: 16

Hydraulic Reservoir Assembly

Ref. No.	Part No.	Qty.	Description
1	353-550	1	Plug-Hydraulic
1:1	237-79	1	O-Ring
2	83-1450	1	Sensor-Level, Oil
3	237-80	1	O-Ring
4	92-8966	1	Tank-Hydraulic
5	83-1520	1	Screen-Filler
6	354-121	1	Fitting-Hydraulic, Straight
7	92-4063	1	Plug-Cap, Filler
8	93-7160	1	Cap-Oil, Hydraulic
9	2412-141	2	Clamp-Drive, Worm
10	83-2070	1	Hose-Valve
11	83-1550	2	Spacer - Tube, Short
12	83-1470	4	Washer - Neoprene
13	3256-71	4	Washer-Flat
14	322-14	2	Screw-HH
15	83-2100	1	Tank-Auxiliary, Hydraulic
15:1	94-8166	1	O-Ring
15:2	83-2250	1	Guage-Sight
16	68-6150	1	Breather-Air
17	322-29	2	Screw-HH
18	83-1560	2	Spacer - Tube, Long
21	354-120	3	Fitting-Hyd, 90°
21:1	237-79	2	O-Ring
22	321-11	2	Screw-HH

Ref. No.	Part No.	Qty.	Description
23	3253-3	2	Washer-Lock/Sp
24	83-1460	1	Solenoid Valve ASM
24:2	83-2000	1	Spool-Valve
24:3	83-2010	1	Coil - Valve
24:3:1	94-5438	1	Seal-Solenoid
25	83-2090	1	Hose-Overflow
26	83-2080	1	Hose-Valve, Tank
27	2412-34	3	Clamp-Hose
28	83-0870	3	Fitting-Barb, Hose
28:1	237-177	1	O-Ring
29	323-6	3	Screw-HH
30	63-8410	3	Washer
31	240-11	3	Grommet-Mount, Tank
32	83-2390	1	Pad - Tank
33	83-2400	2	Spacer/Washer-Tank
34	321-2	1	Screw-HH
35	2412-36	4	Clamp-Hose
36	92-8020	1	Adapter - Breather
37	3256-22	1	Washer-Flat

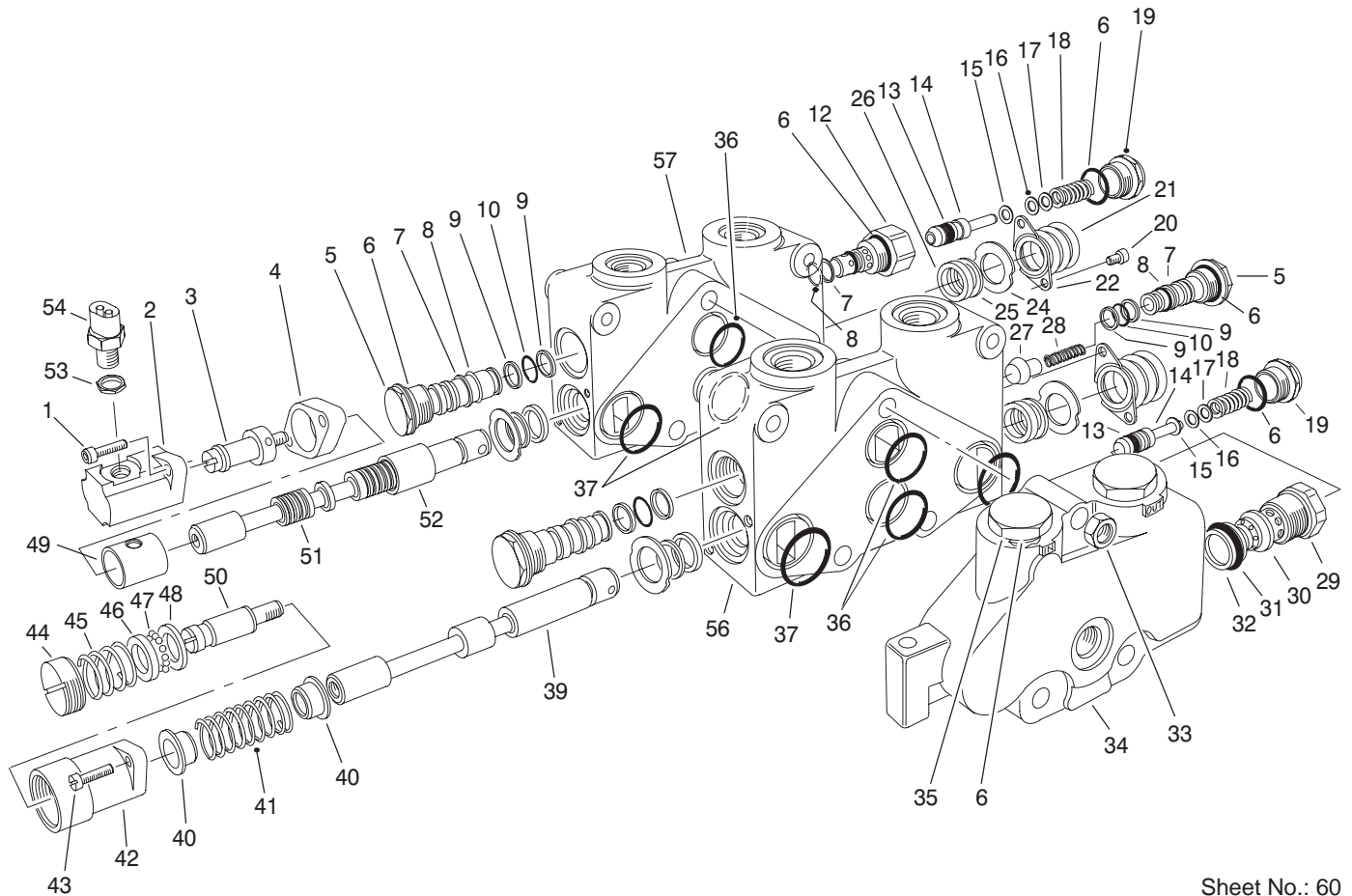

Sheet No.: 60
T-1318

Control Valve Assembly No. 84-2203 (Sections 1&2)

Ref. No.	Part No.	Qty.	Description
1	3274-70	2	Screw-HSH
2	353-727	1	Bonnet-Special
3	353-729	1	Stud-Detent
4	353-733	1	Spacer-Bonnet
5	353-481	3	Lift Check ASM
6	237-54	8	O-Ring
7	353-306	4	Washer-Backup
8	353-305	4	O-Ring
9	353-303	6	Washer-Backup
10	353-302	3	O-Ring
12	353-851	1	Body-Relief
13	353-392	2	Ring-Piston
14	353-531	2	Poppet & Ring ASM
15	353-328	2	.040 Shim
16	353-329	2	.020 Shim
17	353-330	2	.010 Shim
18	353-855	2	Spring
19	353-334	2	Cap-Relief
20	3274-52	4	Screw-HSH
21	353-575	2	Boot
22	93-3651	2	Retainer-Boot
24	92-2547	4	Seal-Retainer
25	92-2546	4	Wiper-Seal
26	353-957	4	Cup-Seal
27	353-301	1	Check-Lift-Poppet
28	353-304	1	Spring-Check, Lift

Ref. No.	Part No.	Qty.	Description
29	353-331	1	O-Ring
30	353-760	1	Relief-Body
31	353-758	1	O-Ring
32	353-952	1	Seal-Back-Up
33	3217-7	3	Nut-Hex
34	353-772	1	Cover-Left
35	353-721	2	Plug
40	353-417	2	Collar-Stop
41	99-6850	1	Spring-Compression
42	99-8181	1	Bonnet-R Det
43	3274-15	2	Screw-HSH
44	353-763	1	Cap-Adj
45	99-1475	1	Spring-Compression
46	42-2680	1	Race-Ball
47	52-5880	12	Ball-Detent
48	354-29	1	Plate-Trust
49	353-728	1	Sleeve
50	353-762	1	Spud-Out, Det
52	353-732	1	Sleeve-Detent
53	38-0410	1	Nut-Hex
54	83-1890	1	Switch-Ball
55	353-766	1	Cart-Relief
56	99-8182	1	Sec 1-V20c Spl ASM
57	353-837	1	Section #2
58	99-8180	1	Positioner-R Det O/Asy

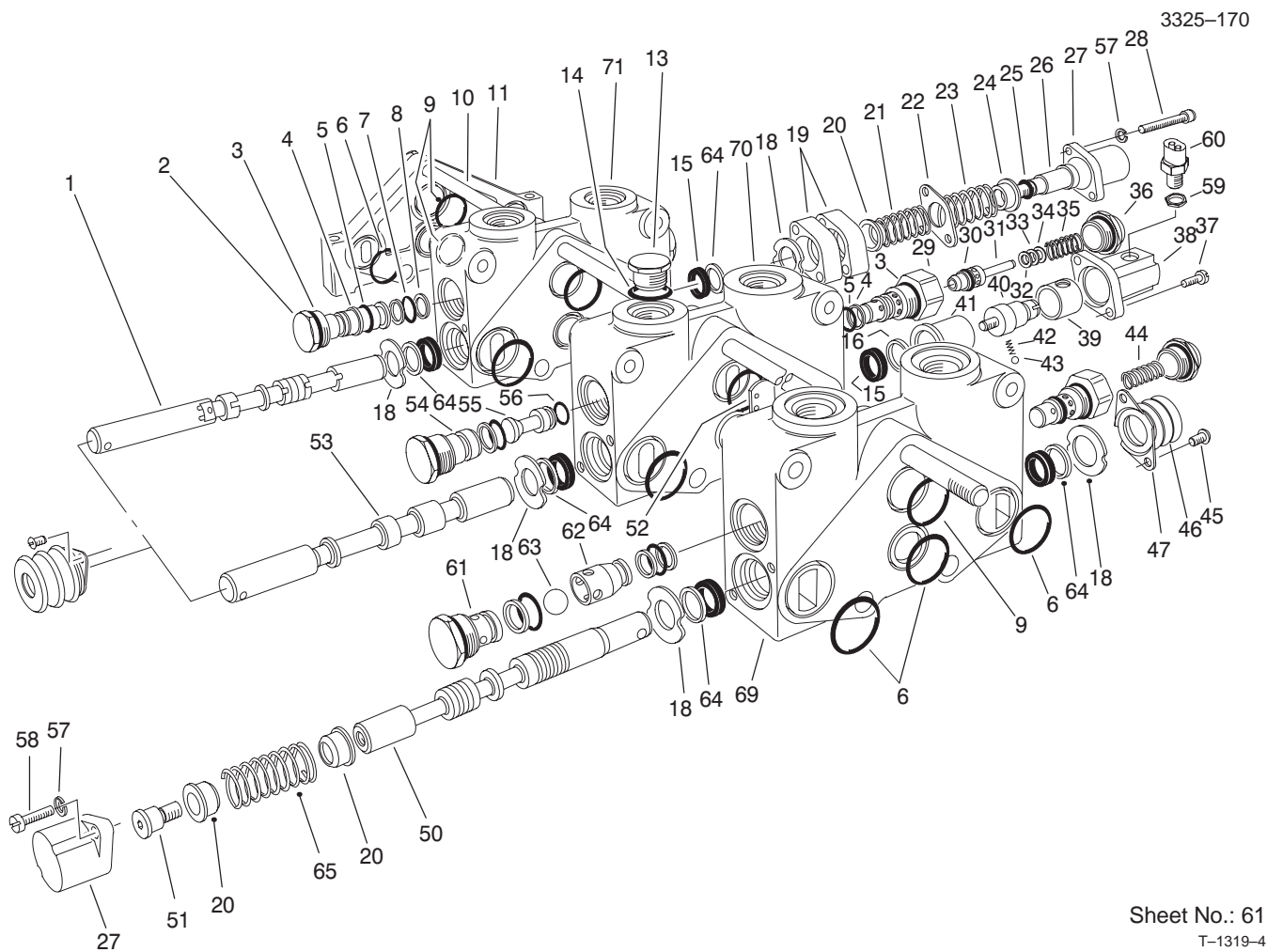

Sheet No.: 61
T-1319-4

Control Valve Assembly No. 84-2203 (Sections 3 Thru 5)

Ref. No.	Part No.	Qty.	Description
1	94-5434	1	Spool
2	353-481	3	Lift Check ASM
3	237-54	6	O-Ring
4	353-306	5	Backup Washer
5	353-305	5	O-Ring
7	353-302	3	O-Ring
8	353-303	6	Washer-Backup
10	353-853	3	Bolt
11	353-668	1	Plate-Cover
13	353-550	1	Plug-Hydraulic
13:1	237-79	1	O-Ring
14	353-848	1	O-Ring
15	353-957	6	Cup-Seal
16	353-958	1	Washer
18	92-2547	5	Seal-Retainer
19	353-733	2	Spacer-Bonnet
20	353-417	3	Collar-Stop
21	353-831	1	Spring
22	353-529	1	Plate-Retainer, Seal
23	92-3148	1	Spring - Traction
24	353-808	1	Spring Collar
25	353-830	1	O-Ring
26	94-4248	1	Collar-Spool
27	99-6895	2	Bonnet
28	354-28	2	Screw-HS
29	353-851	2	Body-Relief

Ref. No.	Part No.	Qty.	Description
30	353-392	2	Ring-Piston
31	353-531	2	Poppet & Ring ASM
32	353-328	2	.040 Shim
33	353-329	2	.020 Shim
34	353-330	2	.010 Shim
35	353-398	1	Spring
36	353-334	2	Cap-Relief
37	52-5900	4	Screw
38	353-847	1	Bonnet
39	353-849	1	Sleeve
40	353-846	1	Spud
41	353-845	1	Sleeve-Detent
42	353-730	1	Spring
43	353-731	1	Ball-1/4 Dia
44	353-855	1	Spring
45	3274-52	6	Screw-HSH
46	353-575	3	Boot
47	93-3651	3	Retainer - Boot
51	52-5860	1	Collar-Spool
52	354-122	1	Spool #4
54	353-953	1	Plug ASM
55	353-844	1	Plug
56	353-850	1	O-Ring
57	3253-3	4	Washer-Lock/Sp
58	3274-84	4	Screw-HSH
59	38-0410	1	Nut-Hex

SPECIAL TOOLS REEL MOTOR SEAL INSTALLATION TOOLS

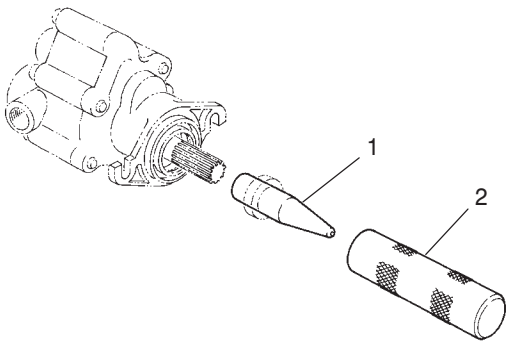

T-0727

Ref. No.	Part No.	Qty.	Description
1	TOR491430	1	Protector-Seal
2	TOR491450	1	Installer-Seal

BED KNIFE SCREW TOOL NO. TOR510880

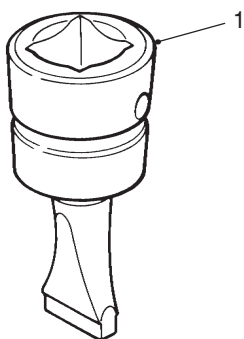

T-0729

Ref. No.	Part No.	Qty.	Description
1		1	Tool-Bed Knife Screw

BEARING REPLACEMENT TOOL KIT NO. TOR238900

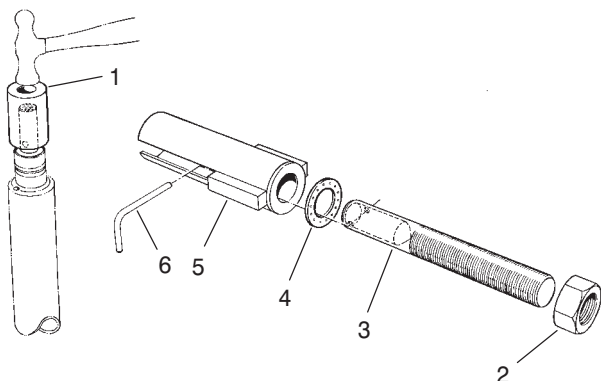

T-0730

Ref. No.	Part No.	Qty.	Description
1	23-8880	2	Driver-Bearing
2	3219-18	1	Nut-Hex
3	23-8840	1	Puller-Bolt
4	22-6090	1	Washer-Thrust
5	23-8850	1	Tube-Support
6	23-8860	1	Pin-Replacement, Bearing

BACKLAPPING BRUSH ASSEMBLY NO. 29-9100

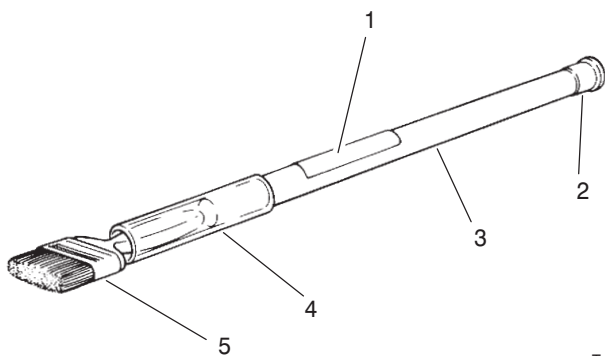

T-0731

Ref. No.	Part No.	Qty.	Description
1	12-9140	1	Decal
2	2410-18	1	Plug
3	29-9080	1	Handle
4	29-9090	1	Hose-Handle
5	36-4310	1	Brush

Note: Special tools may be ordered from: Owatonna Tool Company 2013 4th St. NW Owatonna, MN 55060

SPECIAL TOOLS (Continued)

ALIGNMENT TOOL NO. TOR200120

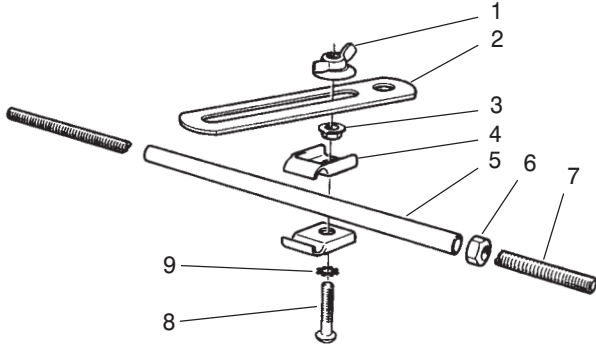

T-0732

Ref. No.	Part No.	Qty.	Description
1	3-4808	1	Nut-Wingl
2	20-0110	1	Bracket-Alignment
3	32123-20	1	Nut-Lock, Flange
4	3-6657	2	Clip-Skid
5	20-0070	1	Tube
6	3219-2	1	Nut-Hex
7	20-0080	1	Rod
8	32122-35	1	Screw-Head, Truss
9	3255-8	1	Washer-Lock, Int. Tooth

**Note: Special tools may be ordered from: Owatonna Tool Company
2013 4th St. NW
Owatonna, MN 55060**

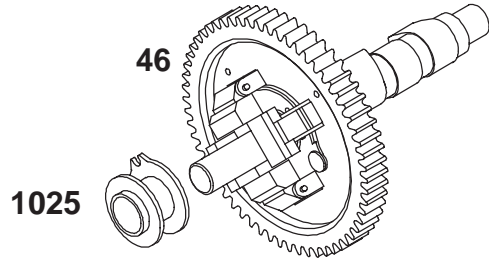
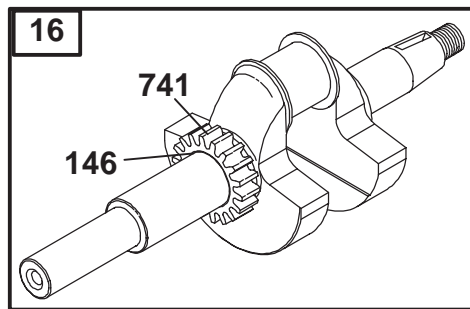
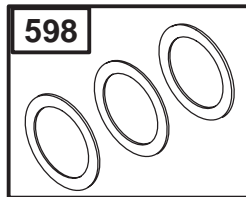
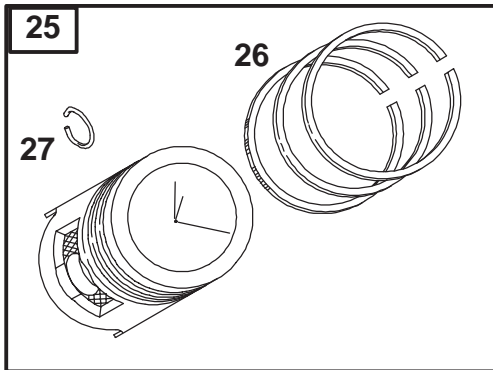
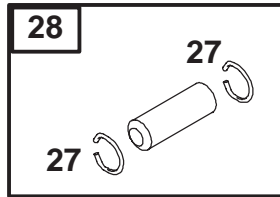
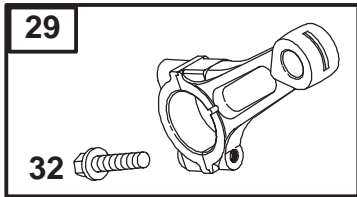

Assemblies include all parts shown in frames.

ENGINE BRIGGS & STRATTON MODEL 350447-1259-E1

Ref. No.	Part No.	Qty.	Description
16	692171	1	Crankshaft
17	690752	1	Ball Bearing
25	808326	1	Piston Assembly (Standard)
	808336	1	Piston Assembly (.010 O.S.)
	808337	1	Piston Assembly (.020 O.S.)
	808338	1	Piston Assembly (.030 O.S.)
26	807889	1	Ring Set (Standard)
	807994	1	Ring Set (.010 O.S.)
	807995	1	Ring Set (.020 O.S.)
	807996	1	Ring Set (.030 O.S.)
27	690683	1	Piston Pin Lock
28	807886	1	Piston Pin (Standard)
29	807900	1	Connecting Rod (Standard)
	807803	1	Connecting Rod (.020 Undersize)
32	690698	1	Screw (Connecting Rod 1 7/8")
46	691557	1	Camshaft
146	691639	1	Timing Key
377	808095	1	Woodruff Key

Ref. No.	Part No.	Qty.	Description
598	807625	1	End Play Shim
741	691530	1	Timing Gear
1025	690689	1	Governor Spool

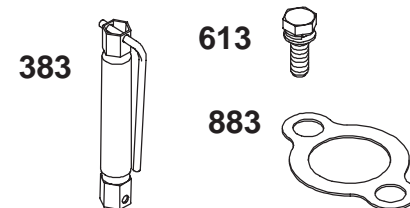
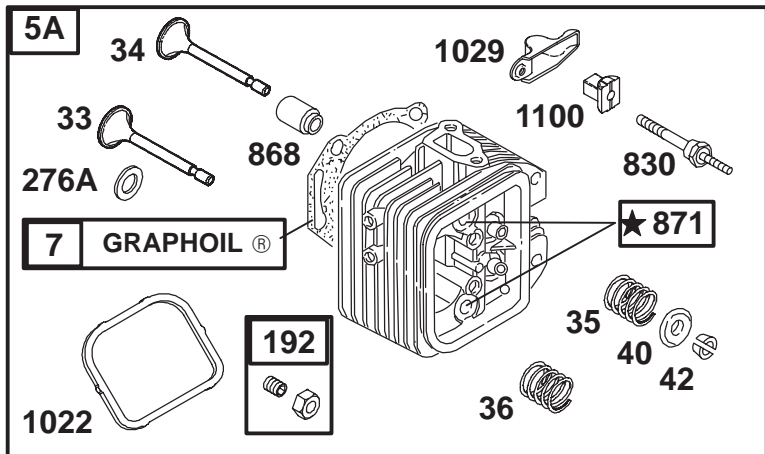
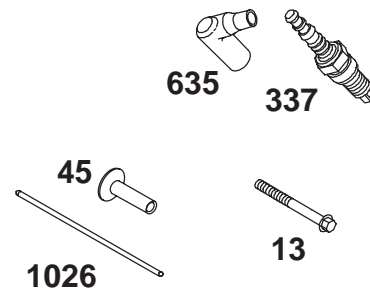
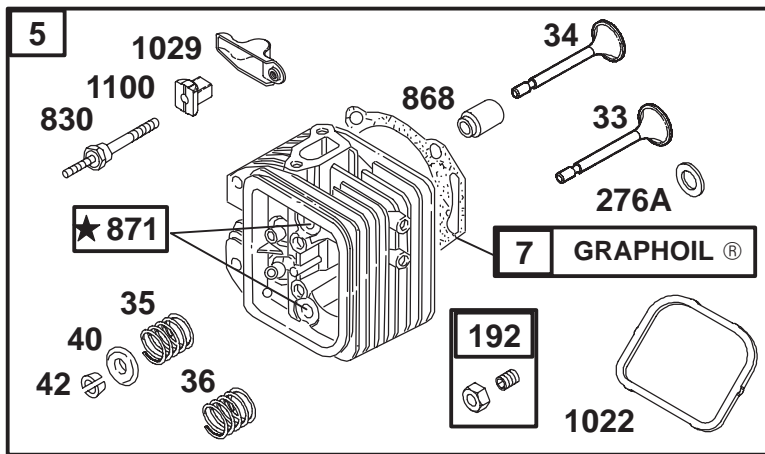

★ REQUIRES SPECIAL TOOLS TO INSTALL. SEE REPAIR INSTRUCTION MANUAL.

Assemblies include all parts shown in frames.

ENGINE BRIGGS & STRATTON MODEL 350447-1259-E1

Ref. No.	Part No.	Qty.	Description
5	808383	1	Cylinder Head (No. 1)
5A	808384	1	Cylinder Head (No. 2)
Δ★7	690888	1	Cylinder Head Gasket
13	692059	1	Screw (Cylinder Head)
33	807681	1	Exhaust Valve
34	807680	1	Intake Valve
35	692084	1	Valve Spring (Intake)
36	692084	1	Valve Spring (Exhaust)
40	692058	1	Valve Retainer
42	807683	1	Valve Retainer
45	690977	1	Valve Tappet
192	807623	1	Rocker Arm Adjuster
Δ★276A	691766	1	Sealing Washer
337	496018	1	Sparkplug
383	19374	1	Sparkplug Wrench
613	691902	1	Screw (Exhaust Manifold)
635	692076	1	Sparkplug Boot
830	691544	1	Stud (Rocker Arm)
868	691963	1	Valve Seal
871	692057	1	Bushing Guide
883	691613	1	Exhaust Gasket

Ref. No.	Part No.	Qty.	Description
Δ★1022	806039	1	Rocker Cover Gasket
1026	691836	1	Push Rod (Steel-Intake)
	691758	1	Push Rod (Aluminum-Exhaust)
1029	691543	1	Rocker Arm
1100	690973	1	Rocker Arm Pivot

★ Included in Engine Gasket Set-Ref. 358.

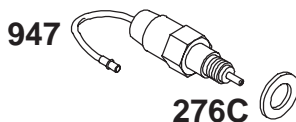
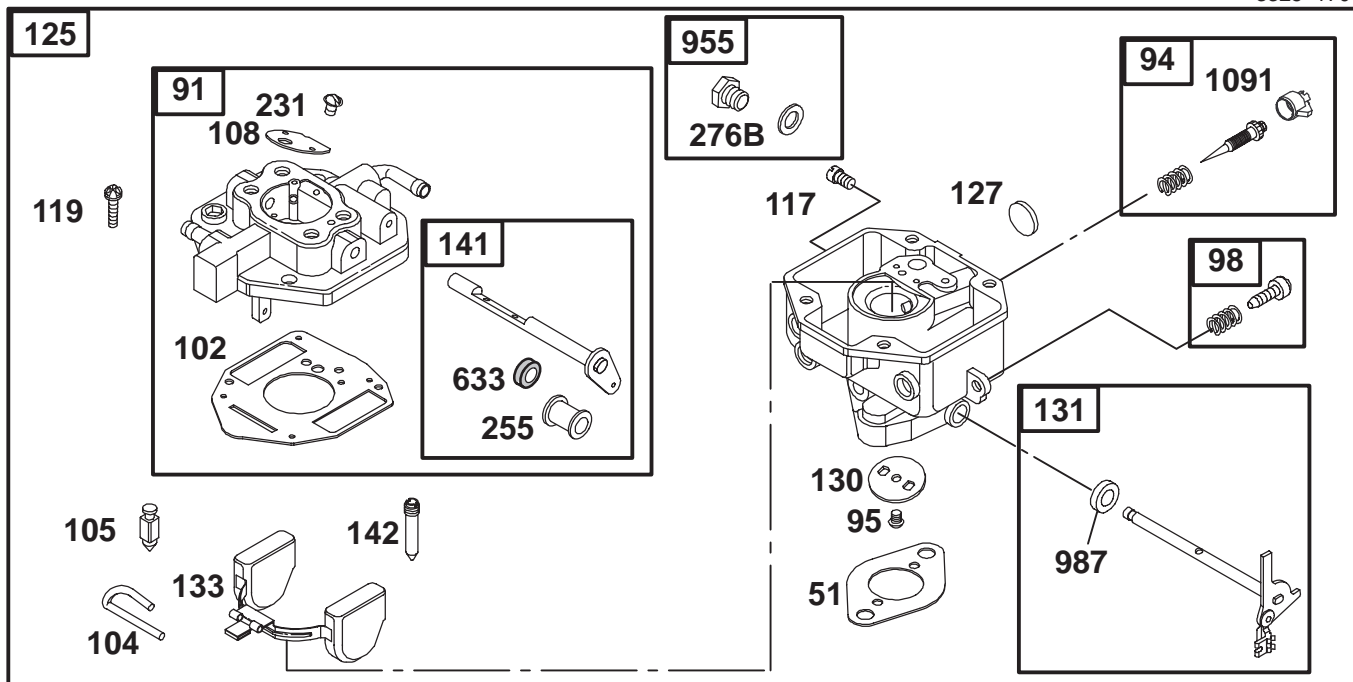

★ **REQUIRES SPECIAL TOOLS TO INSTALL. SEE REPAIR INSTRUCTION MANUAL.**

Assemblies include all parts shown in frames.

ENGINE BRIGGS & STRATTON MODEL 350447-1259-E1

Ref. No.	Part No.	Qty.	Description
★51	691694	1	Intake Gasket
91	808396	1	Upper Carburetor Body
●94	808399	1	Idle Mixture Kit
●95	690718	1	Screw (Throttle Valve)
98	808981	1	Idle Speed Kit
●102	692077	1	Carburetor Body Gasket
●104	690723	1	Float Hinge Pin
●105	692078	1	Float Needle Valve
108	806134	1	Choke Valve
●117	806126	1	Main Jet (Standard)
	808413	1	Main Jet (High Altitude)
119	690720	1	Screw (Upper to Lower Carburetor Body)
125	808985	1	Carburetor
●127	690727	1	Welch Plug
130	806132	1	Throttle Valve
131	808974	1	Throttle Shaft Kit
133	806858	1	Carburetor Float
141	808398	1	Choke Shaft Kit
●142	806128	1	Carburetor Nozzle
●231	690718	1	Screw (Choke Valve)
●255	690721	1	Choke Shaft Bushing
●276B	690724	1	Sealing Washer
●276C	806137	1	Sealing Washer
●633	690722	1	Choke/Throttle Shaft

Ref. No.	Part No.	Qty.	Description
			Seal
947	692094	1	Fuel Solenoid
955	807723	1	Carburetor Plug
●987	806131	1	Throttle Shaft Seal
●1091	691516	1	Limiter Cap

● Included in Carburetor Overhaul Kit-Ref. 121.

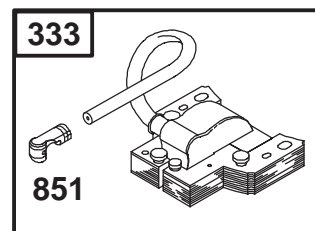
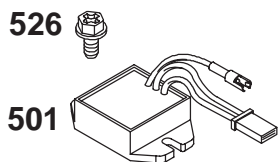
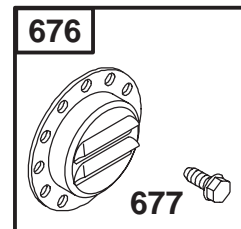
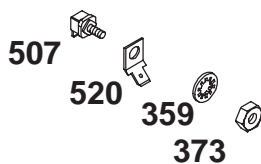
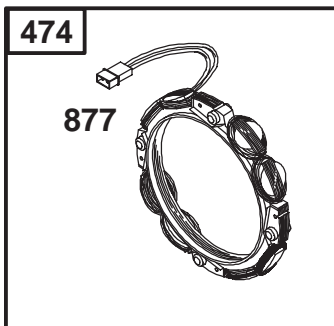

Assemblies include all parts shown in frames.

ENGINE BRIGGS & STRATTON MODEL 350447-1259-E1

Ref. No.	Part No.	Qty.	Description
333	492341	1	Magneto Armature
334	692066	1	Screw (Magneto Armature)
359	691077	1	Washer (Ground Terminal)
373	691612	1	Nut (Ground Terminal)
474	691064	1	Alternator
501	691185	1	Regulator
507	691972	1	Insulator
520	691084	1	Ground Terminal
526	692067	1	Screw (Regulator)
529	690744	1	Grommet
578	692319	1	Wire Assembly
676	397630	1	Muffler Deflector
677	690661	1	Screw (Muffler Deflector)
729	690586	1	Wire Clip
851	493880	1	Sparkplug Terminal
877	399916	1	Alternator Harness
1054	280275	1	Cable Tie
1119	691552	1	Screw (Alternator)

Ref. No.	Part No.	Qty.	Description

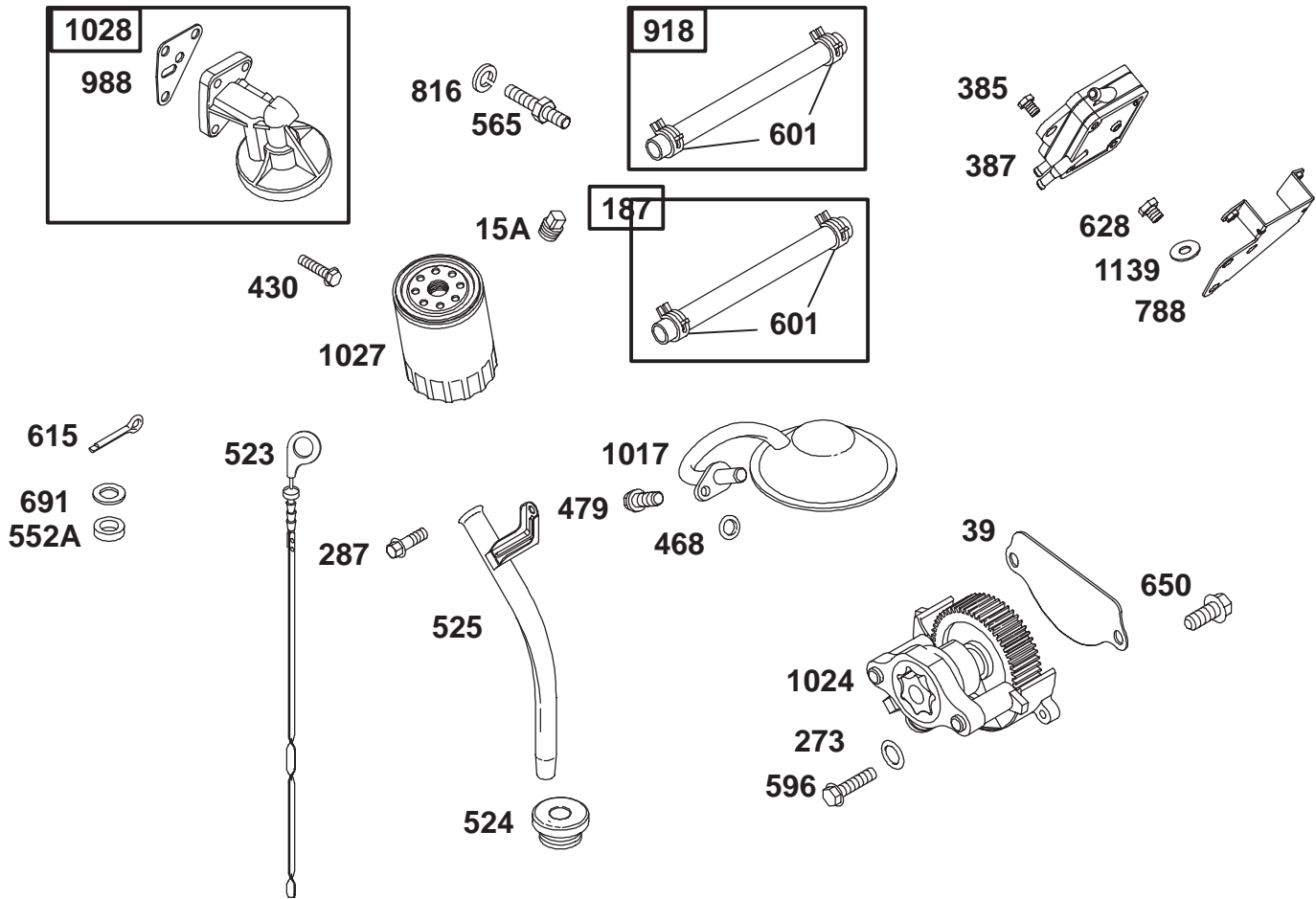

Assemblies include all parts shown in frames.

ENGINE BRIGGS & STRATTON MODEL 350447-1259-E1

Ref. No.	Part No.	Qty.	Description
15A	690283	1	Oil Drain Plug
39	690745	1	Oil Deflector
187	691050	1	Fuel Line (Cut to Required Length)
★273	690681	1	O-Ring Seal (Oil Pump)
287	692062	1	Screw (Dipstick Tube)
385	693169	1	Screw (Fuel Pump)
387	808969	1	Fuel Pump
430	690679	1	Bolt (Oil Pump)
★468	690690	1	O-Ring Seal (Oil Pump Screen)
479	692537	1	Screw (Oil Pump Screen)
523	693175	1	Dipstick
524	693172	1	Dipstick Tube Seal
525	693174	1	Dipstick Tube
552A	690701	1	Governor Crank Bushing
565	690682	1	Stud (Oil Filter)
596	691492	1	Screw (Oil Pump)
601	691038	1	Hose Clamp
615	691550	1	Governor Shaft Retainer
628	692062	1	Screw (Pump Bracket)

Ref. No.	Part No.	Qty.	Description
650	692539	1	Screw (Oil Deflector)
691	690680	1	Governor Shaft Seal
788	691559	1	Pump Bracket
816	690706	1	Washer (Oil Filter)
918	393815	1	Vacuum Hose
★988	692063	1	Oil Adapter Gasket
1017	690900	1	Oil Pump Screen
1024	693185	1	Oil Pump
1027	492932	1	Oil Filter
1028	808235	1	Oil Filter Adapter
1139	806497	1	Washer (Fuel Pump Bracket)

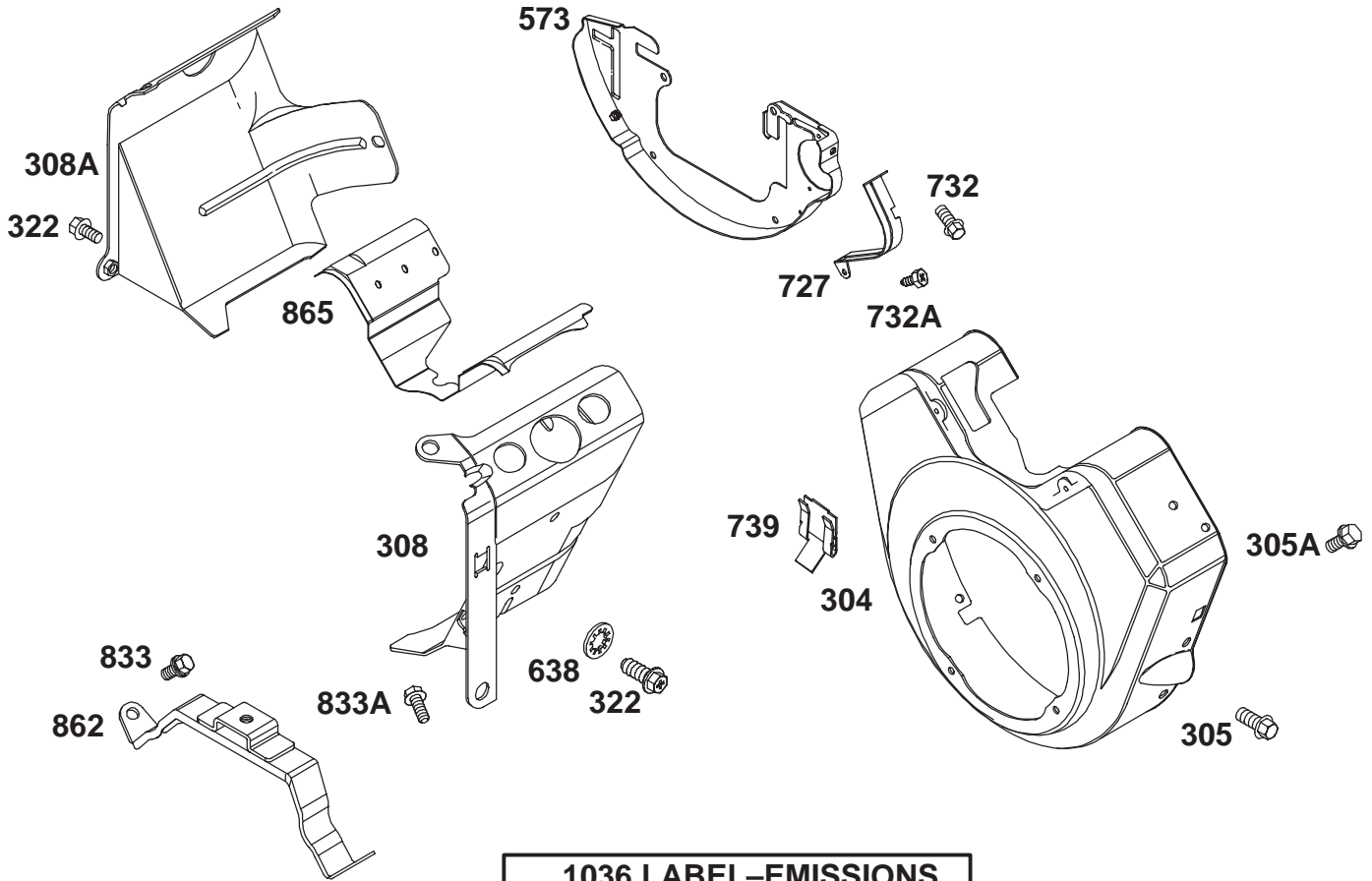

1036 LABEL-EMISSIONS

Assemblies include all parts shown in frames.

ENGINE BRIGGS & STRATTON MODEL 350447-1259-E1

Ref. No.	Part No.	Qty.	Description
304	690929	1	Blower Housing
305	692539	1	Screw (Blower Housing)
305A	692056	1	Screw (Blower Housing)
308	806547	1	Cylinder Head Cover (Cylinder #1)
308A	806546	1	Cylinder Head Cover (Cylinder #2)
322	692539	1	Screw (Cylinder Head Cover)
573	690902	1	Back Plate
638	691551	1	Washer (Cylinder Head Cover)
727	690714	1	Starter Drive Cover
732	692539	1	Screw (Starter Drive Cover)
732A	690688	1	Screw (Starter Drive Cover)
739	690451	1	Debris Clip
833	692539	1	Screw (Cleaner Mounting Strap)
833A	690872	1	Screw (Cleaner Mounting Strap)
862	692153	1	Cleaner Mounting Strap

Ref. No.	Part No.	Qty.	Description
865	690750	1	Air Guide Cover
1036	806688	1	Emissions Label

Hydraulic Schematic

