



Form No. 3426-924 Rev C

Count on it.

Operator's Manual

Debris Blower 600

Model No. 44536—Serial No. 403063082 and Up



This product complies with all relevant European directives; for details, please see the separate product specific Declaration of Conformity (DOC) sheet.



g000502

Figure 1
Safety-alert symbol

⚠ WARNING

CALIFORNIA
Proposition 65 Warning

Use of this product may cause exposure to chemicals known to the State of California to cause cancer, birth defects, or other reproductive harm.

Introduction

This machine is a 3-point hitch, tractor-mounted, debris blower which is intended to be used by professional, hired operators in commercial applications. It is primarily designed to use wind power to quickly clear large areas of unwanted debris on well-maintained lawns in parks, sports fields, and on commercial grounds.

Using this product for purposes other than its intended use could prove dangerous to you and bystanders.

Read this information carefully to learn how to operate and maintain your product properly and to avoid injury and product damage. You are responsible for operating the product properly and safely.

Visit www.Toro.com for product and accessory information, help finding a dealer, or to register your product.

Whenever you need service, genuine Toro parts, or additional information, contact an Authorized Service Dealer or Toro Customer Service and have the model and serial numbers of your product ready. Write the numbers in the space provided.

Model No. _____

Serial No. _____

This manual identifies potential hazards and has safety messages identified by the safety-alert symbol (Figure 1), which signals a hazard that may cause serious injury or death if you do not follow the recommended precautions.

This manual uses 2 words to highlight information. **Important** calls attention to special mechanical information and **Note** emphasizes general information worthy of special attention.

Contents

Safety	3
General Safety	3
Safety and Instructional Decals	3
Setup	5
1 Applying the Entanglement Decal	5
2 Installing the Caster Wheels.....	6
3 Connecting the Lower Link Arms.....	7
4 Connecting the Upper Link.....	7
5 Adjusting the PTO Shaft Length	8
6 Connecting the PTO Shaft	9
7 Adjusting the Sway Links	9
8 Adjusting the 3-Point-Lift Stop.....	9
9 Removing the Blower from the Tractor.....	10
10 Greasing the Blower	10
Product Overview	11
Specifications	11
Attachments/Accessories	11
Before Operation	11
Before Operation Safety	11
Adjusting the Discharge Direction	12
During Operation	12
During Operation Safety	12
Operating Tips	13
After Operation	14
After Operation Safety	14
Hauling	14
Maintenance	15
Maintenance Safety.....	15
Recommended Maintenance Schedule(s)	15
Lubrication	16
Greasing the Machine.....	16
Belt Maintenance	17
Adjusting the Blower Belt	17
Storage	18
Troubleshooting	19

Safety

General Safety

This product is capable of throwing objects. Always follow all safety instructions to avoid serious personal injury.

Using this product for purposes other than its intended use could prove dangerous to you and bystanders.

- Read and understand the contents of both this *Operator's Manual* and the operator's manual of the traction unit before using this machine. Ensure that everyone using this product knows how to use this machine and the traction unit and understands the warnings.
- Use your full attention while operating the machine. Do not engage in any activity that causes distractions; otherwise, injury or property damage may occur.

- Do not put your hands or feet near moving components of the machine.
- Do not operate the machine without all guards and other safety protective devices in place and working on the machine.
- Keep children, bystanders, and pets out of the operating area. Never allow children to operate the machine.
- Always shut off the traction unit engine, remove the key (if equipped), wait for all moving parts to stop, and allow the machine to cool before adjusting, repairing, cleaning, or storing the machine.

Improperly using or maintaining this machine can result in injury. To reduce the potential for injury, comply with these safety instructions and always pay attention to the safety-alert symbol (▲), which means Caution, Warning, or Danger—personal safety instruction. Failure to comply with these instructions may result in personal injury or death.

Safety and Instructional Decals



Safety decals and instructions are easily visible to the operator and are located near any area of potential danger. Replace any decal that is damaged or missing.

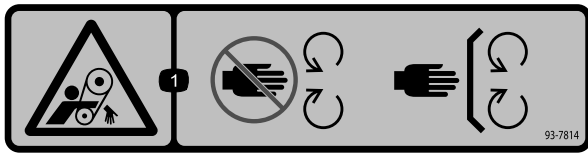

93-7814

decal93-7814

1. Entanglement hazard, belt—stay away from moving parts; keep all guards and shields in place.

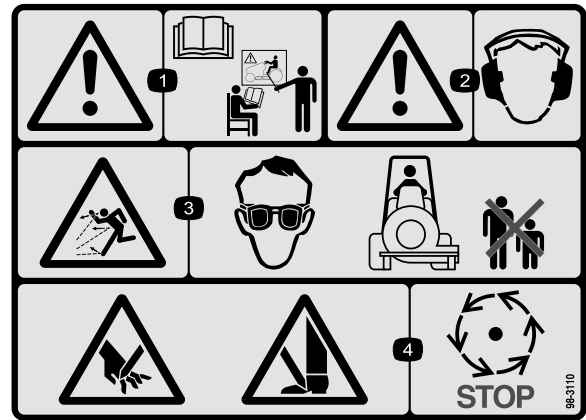

98-3110

decal98-3110

1. Warning—read the *Operator's Manual* and receive training.
2. Warning—wear hearing protection.
3. Thrown object hazard—wear eye protection and keep bystanders away from the machine.
4. Cutting hazard of hand or foot—wait for moving parts to stop.

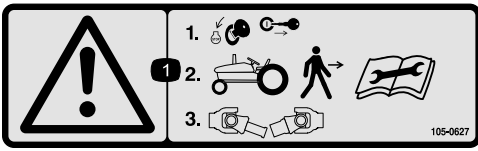

105-0627

decal105-0627

1. Warning—stop the engine, remove the ignition key before leaving the machine and disconnect the power take-off (PTO) shaft.

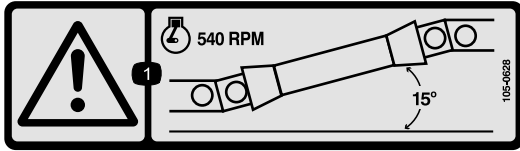

105-0628

decal105-0628

1. Warning—do not operate the machine with power take-off (PTO) at a greater angle than 15 degrees.

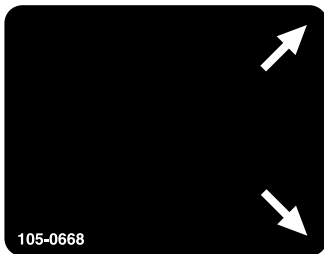

105-0668

decal105-0668



105-0669

decal105-0669

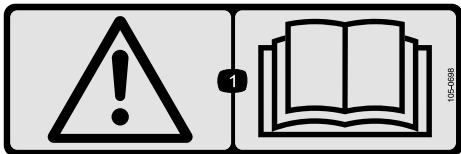

105-0698

decal105-0698

1. Warning—read the *Operator's Manual*.

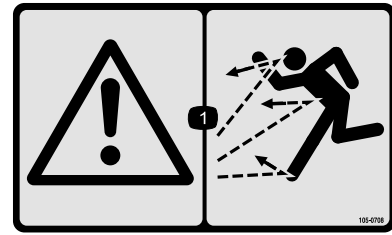

105-0708

decal105-0708

1. Warning—thrown object hazard; keep bystanders away from machine.

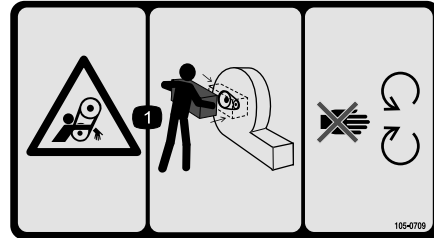

105-0709

decal105-0709

1. Entanglement hazard, belt—keep all guards and shields in place; stay away from moving parts.

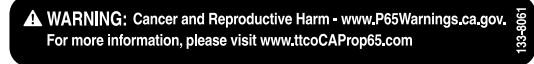

133-8061

decal133-8061

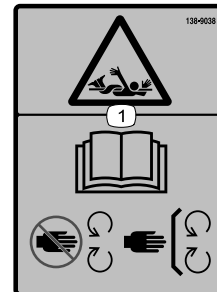

138-9038

decal138-9038

1. Entanglement hazard—read the *Operator's Manual*; stay away from moving parts; keep all guards and shields in place.

Setup

Loose Parts

Use the chart below to verify that all parts have been shipped.

Procedure	Description	Qty.	Use
1	CE entanglement decal	1	Apply the entanglement decal—CE mowers
2	No parts required	–	Install the caster wheels.
3	No parts required	–	Connect the lower link arms.
4	No parts required	–	Connect the upper link.
5	No parts required	–	Adjust the PTO shaft length.
6	No parts required	–	Connect the PTO shaft.
7	No parts required	–	Adjust the sway links.
8	No parts required	–	Adjust the 3-point-lift stop.
9	No parts required	–	Remove the blower from the tractor.
10	No parts required	–	Grease the blower.

Media and Additional Parts

Description	Qty.	Use
Operator's Manual	1	Review the manual before operating the machine.
Declaration of Conformity	1	For CE compliance.

Note: Determine the left and right sides of the machine from the normal operating position.

1

Applying the Entanglement Decal

CE Mowers

Parts needed for this procedure:

1	CE entanglement decal
---	-----------------------

Procedure

Important: This procedure is required for all CE countries and anywhere English is commonly spoken.

1. Rotate the PTO shaft guard to access the existing entanglement decal (Figure 2).

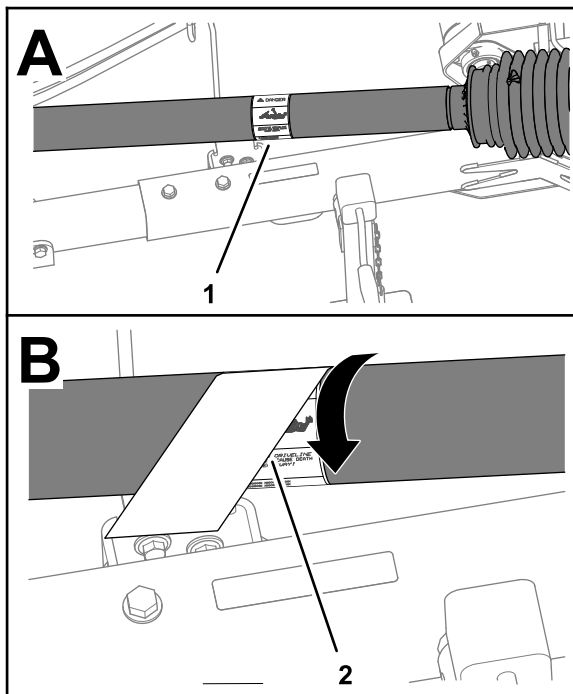

Figure 2

g262546

1. Existing entanglement decal
2. CE entanglement decal

2. Clean the existing entanglement decal and the guard area surrounding the decal.
3. Remove the backing from the CE entanglement decal.
4. Place the CE entanglement decal over the existing entanglement decal (Figure 2).

2

Installing the Caster Wheels

No Parts Required

Procedure

Install a caster wheel assembly between each caster fork with 4 washers, an axle, and 2 cotter pins (Figure 3).

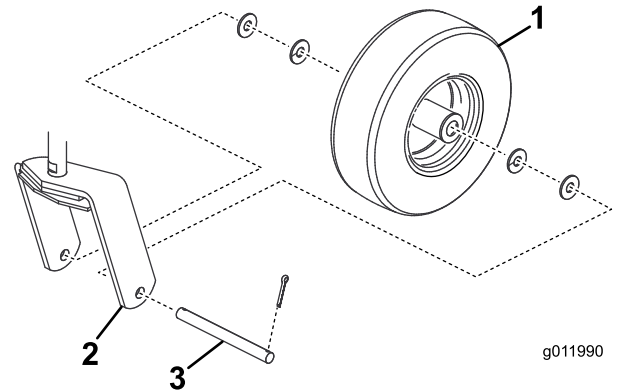

g011990

g011990

Figure 3

1. Wheel assembly
2. Caster fork
3. Axle

3

Connecting the Lower Link Arms

No Parts Required

Procedure

1. Position the blower on a flat, level surface and disengage the PTO.
2. Back the tractor squarely up to the blower until the lower link arms are aligned with the hitch pins.
3. Engage the parking brake, shut off the traction unit engine, and remove the key from the ignition.

Note: Wait for the traction unit engine and all moving parts to stop before leaving the operator's seat.

4. Insert the right and left, lower link arms onto the hitch pins (Figure 4).

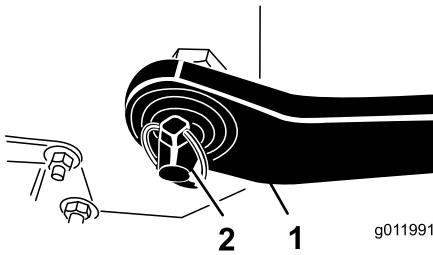

Figure 4

1. Lower link
2. Lynch pin

5. Secure the lower link arms to the hitch pins with the lynch pins (Figure 4).

4

Connecting the Upper Link

No Parts Required

Procedure

1. Connect the upper link to the holes in the blower bracket and secure it with a clevis pin and lynch pin (Figure 5).

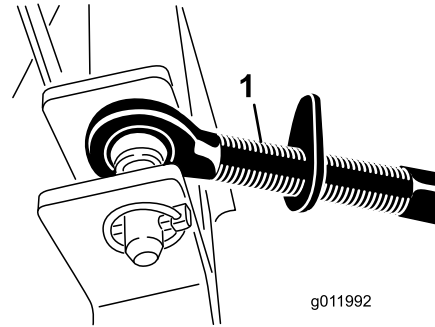

Figure 5

1. Upper link

2. Rotate the adjusting link to tighten the link.

Note: Do not overtighten to raise the back end of the blower off the ground.

3. Tighten the locknut to secure the upper link into position.

5

Adjusting the PTO Shaft Length

No Parts Required

Procedure

Important: A long PTO shaft is supplied with the machine to accommodate large variations in the tractor's PTO and 3-point locations. For most machines, this shaft is too long and must be cut to the correct length, or damage may result.

Important: Incorrect PTO shaft length can cause machine and/or attachment damage and personal injury.

1. With the blower on a level surface, lower the blower until the input shaft is approximately the same height as the tractor PTO shaft.

Note: This is the shortest distance between the 2 shafts.

2. Measure the distance from the lock groove of the tractor PTO shaft to the lock groove at the blower-input shaft.

Note: Record this dimension.

3. Fully collapse the PTO shaft and measure the distance between the lock pin collars.

Note: Record this dimension.

4. At the shortest length of the shaft, the 2 halves of the PTO shaft must have at least 37 mm (1-1/2 inches) of additional clearance to collapse (Figure 5).

Note: If the dimension in step 2 is not at least 37 mm (1-1/2 inches) greater than the dimension in step 3, the PTO shaft is too long; proceed to step 5. If there is enough clearance to allow the PTO shaft to collapse, proceed to step 10.

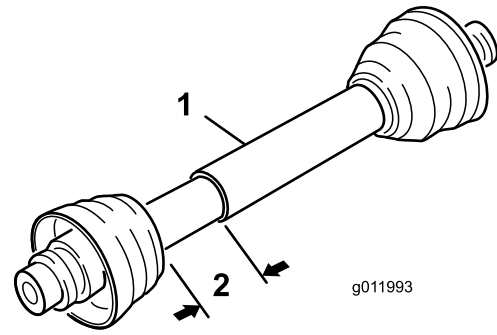

Figure 6

1. PTO shaft
2. 37 mm (1-1/2 inches) dimension

5. Use the following calculation to establish how much shorter the shaft must be, when connected, to ensure a clearance of 37 mm (1-1/2 inches):
 - A. Subtract the dimension recorded in step 3 from the dimension recorded in step 2.

Note: Record this dimension.
 - B. Subtract the result in step 5A from 37 mm (1-1/2 inches).

Note: The PTO shaft must be shortened by this amount.
6. Cut the guards and the steel tubes shorter by the calculated length.

Note: Cut both halves of the PTO shaft.
7. Deburr the ends of the steel tubes internally and externally.
8. Remove all debris from the tube sections.
9. Grease the steel tubes.
10. Assemble the PTO shaft and secure it to the blower and tractor.
11. Measure the shaft.

Note: If it is not at least 37 mm (1-1/2 inches), repeat the procedure.
12. Raise the blower to the highest position.

Note: There must be at least 75 mm (3 inches) of overlap of the halves. Adjust the 3-point-lift stop, if necessary; refer to [8 Adjusting the 3-Point-Lift Stop \(page 9\)](#).

6

Connecting the PTO Shaft

No Parts Required

Procedure

1. Connect the PTO shaft to the blower-input shaft.
2. Connect the PTO shaft to the rear tractor PTO shaft.
3. Slide the PTO shaft fully forward.
4. Depress the pin to secure the PTO shaft in place and slide the PTO shaft back and forth to ensure that it is properly locked.
5. Connect the guard safety chains from the power shaft sections to the welded clips on the link arms or to the PTO guards (Figure 7).

Note: Ensure that the chains have slack when the blower is raised or lowered.

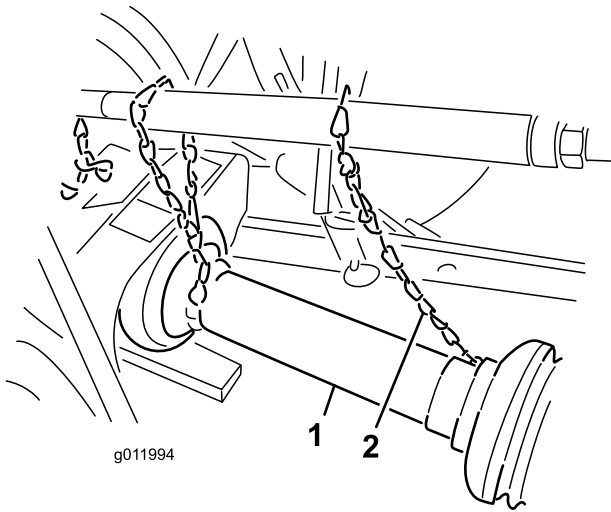

Figure 7

1. PTO guard
2. Safety chain

7

Adjusting the Sway Links

No Parts Required

Procedure

Adjust the sway links on the lower draft arms of the 3-point hitch to minimize side-to-side sway to a maximum of 25 mm (1 inch) on each side.

1. Adjust the lower links inboard until they contact the blower mounting plates (Figure 8).

Note: This will reduce the stress on the pins. If the tractor has sway chains instead of sway links, install the washers between the lower link arm and lynch pin to reduce the overhung load on the lift pins.

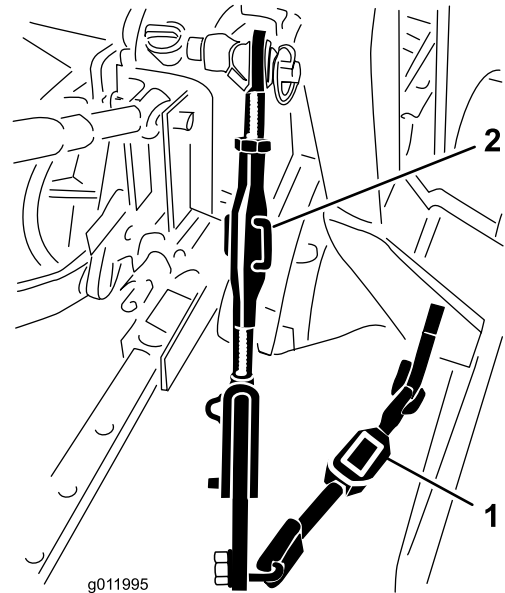

Figure 8

1. Sway link
2. Link body

2. Turn the adjustable-link body (if provided) to raise or lower the link arm until the blower is leveled from side to side (Figure 8).

Note: Refer to the tractor operator's manual for additional installation and adjustment procedures.

⚠ WARNING

If the guard chains are not connected, they could rotate during operation and cause bodily injury.

Keep all PTO guards in place and connect the guard chains to the link arms or PTO guards.

8

Adjusting the 3-Point-Lift Stop

No Parts Required

Procedure

Adjust and set the 3-point-lift stop to provide approximately 10 cm (4 inches) ground clearance, when in the raised position, to minimize the PTO angle when raising the blower. For transporting or trailer loading/unloading, the full-lift range can be used as long as the PTO tubes do not slide apart (Figure 9).

Important: Operating the PTO in the fully-raised position may damage the PTO or other components

Note: Refer to the tractor operator's manual for adjustment procedures.

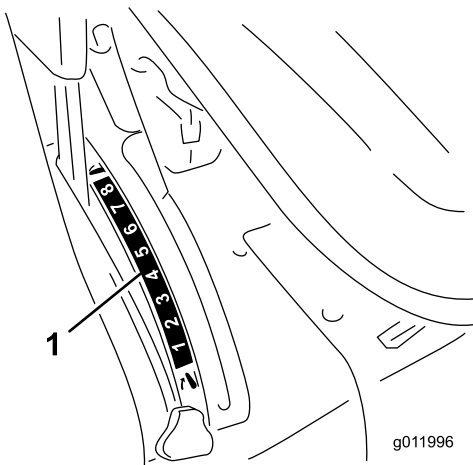

Figure 9

1. 3-point-lift stop

9

Removing the Blower from the Tractor

No Parts Required

Procedure

1. Park the machine on a level surface, disengage the PTO, engage the parking brake, shut off the traction unit engine, and remove the key from the ignition.
2. Disconnect the guard safety chains from the tractor PTO.

Note: Secure the end of the chain to the blower side of the PTO shaft to prevent the PTO shaft from coming apart.

3. Slowly lower the blower until the roller and caster wheels contact the ground.
4. Remove the lynch pin and top link pin securing the center link to the bracket.
5. Disconnect the power shaft from the tractor PTO shaft.
6. Slide the power shaft rearward and remove it from the tractor.
7. Remove the lynch pins and slide the lower link arms off the hitch pins.

10

Greasing the Blower

No Parts Required

Procedure

Before operating the blower, lubricate the PTO drive-shaft; refer to [Greasing the Machine \(page 16\)](#).

Important: Failure to properly grease the unit will result in premature failure of critical parts.

Product Overview

Specifications

Note: Specifications and design are subject to change without notice.

Length	125 cm (49 inches)
Width	150 cm (59 inches)
Height	117 cm (46 inches)
Net weight	227 kg (500 lbs)

Attachments/Accessories

A selection of Toro approved attachments and accessories is available for use with the machine to enhance and expand its capabilities. Contact your Authorized Service Dealer or authorized Toro distributor or go to www.Toro.com for a list of all approved attachments and accessories.

To ensure optimum performance and continued safety certification of the machine, use only genuine Toro replacement parts and accessories. Replacement parts and accessories made by other manufacturers could be dangerous, and such use could void the product warranty.

Operation

Note: Determine the left and right sides of the machine from the normal operating position.

Before Operation

Before Operation Safety

General Safety

- Never allow children or untrained people to operate or service the machine. Local regulations may restrict the age of the operator. The owner is responsible for training all operators and mechanics.
- Become familiar with the safe operation of the equipment, operator controls, and safety signs.
- Always shut off the traction unit engine, remove the key, wait for all moving parts to stop, and allow the machine to cool before adjusting, repairing, cleaning, or storing the machine. Know how to stop the machine and shut off the engine quickly.
- Keep all guards, safety devices, and decals in place. Repair or replace all safety devices and replace all illegible or missing decals. Do not operate the machine unless they are present and functioning properly.
- Each time an attachment or implement is mounted, check the 3-point-hitch movement. Ensure that there is no interference with hoses and attachment parts when operating the 3-point hitch.
Important: You can damage the PTO shaft if you operate attachments at too high of an angle.
- Attachments can change the stability and the operating characteristics of the traction unit.
- Locate the pinch point areas marked on the traction unit and attachments and keep your hands and feet away from these areas.
- Ensure that the traction unit is suitable for use with an implement of this weight by checking with the traction unit supplier or manufacturer.
- Do not modify this equipment in any manner.

Adjusting the Discharge Direction

The direction of the discharge opening can be changed from the side to the front by moving the control handle (Figure 10).

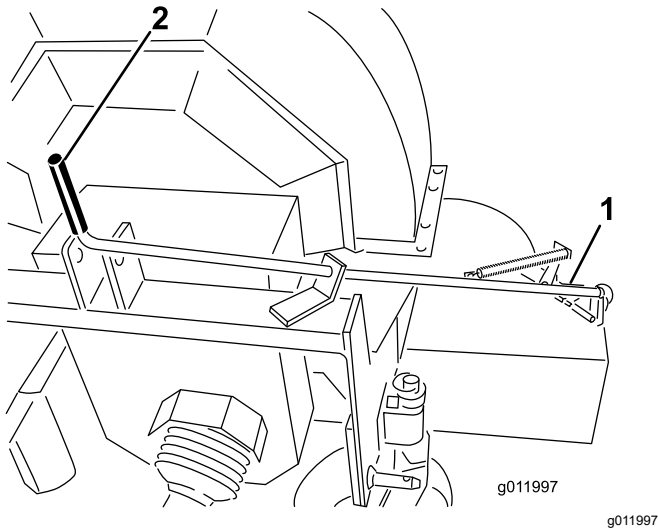

Figure 10

1. Discharge opening 2. Control handle

During Operation

During Operation Safety

General Safety

- The owner/operator can prevent and is responsible for accidents that may cause personal injury or property damage.
- Wear appropriate clothing, including eye protection; long pants; substantial, slip-resistant footwear; and hearing protection. Tie back long hair and do not wear loose jewelry.
- Do not operate the machine while ill, tired, or under the influence of alcohol or drugs.
- Use your full attention while operating the machine. Do not engage in any activity that causes distractions; otherwise, injury or property damage may occur.
- Discharged air has considerable force and could cause injury or loss of footing. Stay away from the blower nozzle when the machine is operating.
- Keep all bystanders away; shut off the machine when bystanders enter the area, do not direct discharge toward them.
- Do not operate the machine when it is not connected to a towing vehicle.
- Do not run the traction unit engine in a confined area without adequate ventilation. Engine exhaust contains carbon monoxide, an odorless gas that is fatal if inhaled.
- Do not carry passengers on the machine and keep bystanders and pets away from the machine during operation.
- Operate the machine only in good visibility to avoid holes or hidden hazards.
- Look behind and down before backing up to be sure of a clear path.
- Use care when approaching blind corners, shrubs, trees, or other objects that may obscure your vision.
- Never leave a running machine unattended.
- When transporting the machine on public roads, follow all traffic regulations and use any additional accessories that may be required by law, such as lights, turn signals, slow-moving vehicle (SMV) signs, and others as required.
- If the machine ever vibrates abnormally, stop the machine immediately, shut off the traction unit engine, remove the key, wait for all moving parts to stop, and inspect for damage. Repair all damage to the machine before resuming operation.

- Reduce speed when operating on rough, uneven terrain, and near curbs, holes, and other sudden changes in terrain.
- To avoid causing the machine to tip over, be careful when turning and avoid unsafe maneuvers.
- For all PTO shaft steel parts (tubes, bearings, joints, etc.) disassembly or repairs, it is highly advisable to contact your local Toro distributor. Removal of components for repairs and reassembly may damage some parts if not performed with special tools by trained technicians.
- The PTO shaft must not be used without the guards supplied.

caves in. Establish a safety area between the machine and any hazard.

Operating Tips

⚠ WARNING

Discharged air has considerable force and could cause injury or loss of footing.

- **Stay away from the discharge opening when the machine is operating.**
- **Keep bystanders away from the discharge opening when the machine is running.**

1. Start the tractor and run it at a low engine speed.
2. Engage the PTO while the engine is at idle speed.
3. Increase the tractor PTO speed to 540 rpm.
4. Practice blowing material.

Note: Blow in the same direction that the wind is blowing to prevent material from blowing back into the cleared area.

Slope Safety

- Review the traction unit specifications to ensure that you do not exceed its slope capabilities.
- Slopes are a major factor related to loss of control and rollover accidents, which can result in severe injury or death. You are responsible for safe slope operation. Operating the machine on any slope requires extra caution.
- Evaluate the site conditions to determine if the slope is safe for machine operation, including surveying the site. Always use common sense and good judgment when performing this survey.
- Review the slope instructions, listed below, for operating the machine on slopes. Before you operate the machine, review the site conditions to determine whether you can operate the machine in the conditions on that day and at that site. Changes in the terrain can result in a change in slope operation for the machine.
 - Avoid starting, stopping, or turning the machine on slopes. Avoid making sudden changes in speed or direction. Make turns slowly and gradually.
 - Do not operate a machine under any conditions where traction, steering, or stability is in question.
 - Remove or mark obstructions such as ditches, holes, ruts, bumps, rocks, or other hidden hazards. Tall grass can hide obstructions. Uneven terrain could overturn the machine.
 - Be aware that operating the machine on wet grass, across slopes, or downhill may cause the machine to lose traction.
 - Use extreme caution when operating the machine near drop-offs, ditches, embankments, water hazards, or other hazards. The machine could suddenly roll over if a wheel goes over the edge or the edge

After Operation

After Operation Safety

General Safety

- Park the machine on a firm, level surface; shut off the traction unit engine, remove the key, wait for all moving parts to stop, and allow the machine to cool before adjusting, repairing, cleaning, or storing the machine.
- Only disconnect the machine from the traction unit while on a level surface.
- When disconnecting the machine, always chock the wheels to prevent movement.
- Keep all parts of the machine in good working condition and all hardware tightened.
- Replace all worn, damaged, or missing decals.

Hauling

- Use care when loading or unloading the machine into a trailer or truck.
- Use full-width ramps for loading machine into trailer or truck.
- Tie the machine down securely using straps, chains, cable, or ropes. Direct both the front and rear straps down and outward from the machine.

Maintenance

▲ CAUTION

Failure to properly maintain the machine could result in premature failure of machine systems causing possible harm to you or bystanders.

Keep the machine well maintained and in good working order as indicated in these instructions.

Note: Determine the left and right sides of the machine from the normal operating position.

Maintenance Safety

- Before cleaning, servicing, or adjusting the machine, do the following:
 - Park the machine on a level surface.
 - Shut off the traction unit engine, remove the key, and wait for all moving parts to stop.
 - Chock the wheels.
 - Allow machine components to cool before performing maintenance.
- Perform only those maintenance instructions described in this manual. If major repairs are ever needed or you need assistance, contact an authorized Toro distributor.
- Do not rely on a hydraulic system to support the machine; support the machine with blocks or jack stands when working beneath it.
- Ensure that all guards are installed securely after maintaining or adjusting the machine.
- Do not allow untrained personnel to service the machine.
- Carefully release pressure from components with stored energy.
- Keep all parts in good working condition and all fasteners tightened. Replace all damaged or missing decals.
- Do not interfere with the intended function of a safety device or reduce the protection provided by a safety device. Check their proper operation regularly.
- If major repairs are ever necessary or assistance is required, contact an authorized Toro distributor.
- Altering this machine in any manner may affect the operation of the machine, performance, durability, or its use may result in injury or death. Such use could void the product warranty of The Toro® Company.

Recommended Maintenance Schedule(s)

Maintenance Service Interval	Maintenance Procedure
Every 20 hours	<ul style="list-style-type: none">• Check and/or adjust the blower-belt tension.
Every 100 hours	<ul style="list-style-type: none">• Grease the fan shaft bearings.• Grease the caster wheel fittings.• Grease the 2 drive-shaft fittings.

Lubrication

Greasing the Machine

The machine has grease fittings that you must lubricate regularly with No. 2 lithium grease.

Fan-Shaft Bearings

Service Interval: Every 100 hours

Grease the 2 fan shaft bearings (Figure 11).

Note: Remove belt cover to access rear fitting.

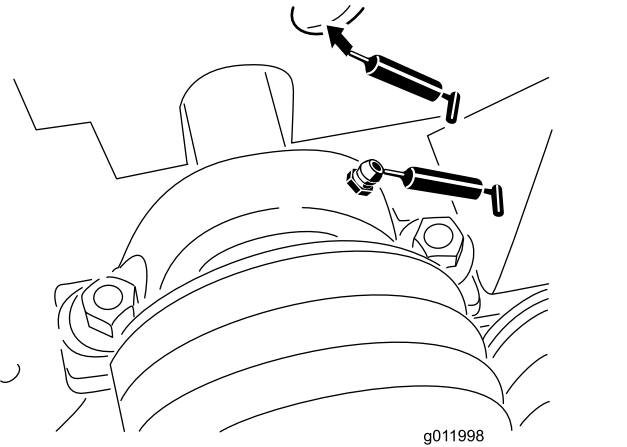

Figure 11

Drive Shaft

Service Interval: Every 100 hours

Grease the 2 drive-shaft fittings (Figure 13).

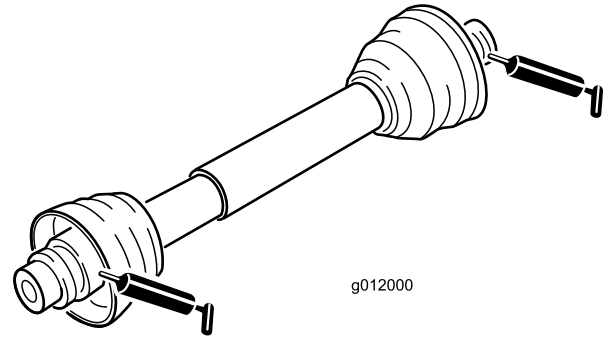

Figure 13

Caster Wheels

Service Interval: Every 100 hours

Grease the 2 caster wheel fittings (Figure 12).

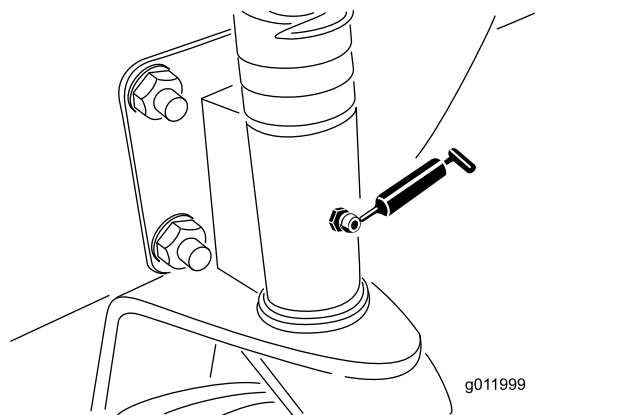

Figure 12

Belt Maintenance

Adjusting the Blower Belt

Service Interval: Every 20 hours

Ensure that the belt is properly tensioned to ensure proper operation of the machine and unnecessary wear. Check the belt frequently.

Important: The fasteners on the covers of this machine are designed to remain on the cover after removal. Loosen all of the fasteners on each cover a few turns so that the cover is loose but still attached, then go back and loosen them until the cover comes free. This prevents you from accidentally stripping the bolts free of the retainers.

1. Remove the capscrews, washers, and nuts securing the belt guard to the blower housing (Figure 14).

Note: The drive shaft does not have to be disconnected to adjust the belt.

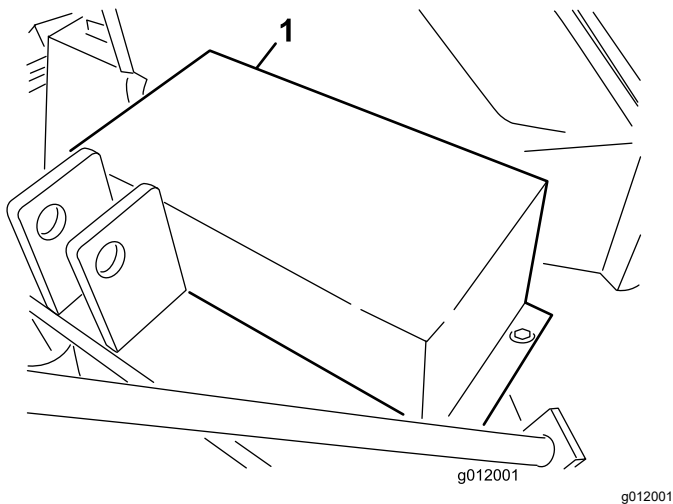

Figure 14

1. Belt guard

2. Remove the belt guard (Figure 14).
3. Remove capscrew and nut securing the tensioner guide to the blower frame (Figure 15).

Note: The belt tension releases when the capscrew is removed.

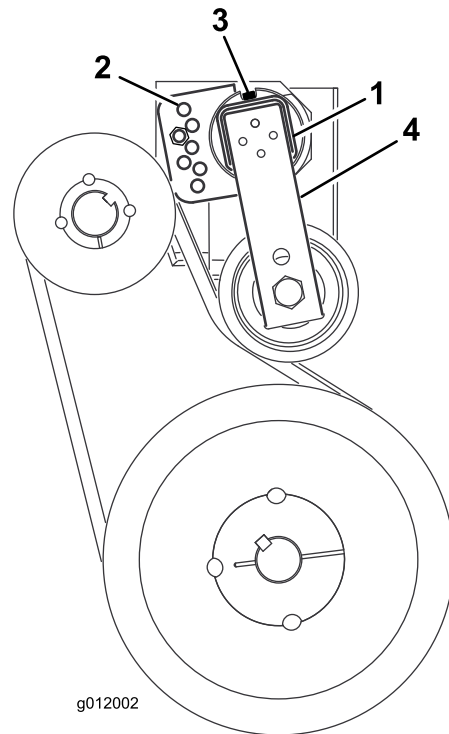

Figure 15

- | | |
|------------------------|--------------|
| 1. Belt-tensioner tube | 3. Capscrew |
| 2. Tensioner guide | 4. Idler arm |

4. On the rear of the frame, loosen the capscrew securing the belt tensioner to frame (Figure 15).
 5. Position a large wrench on the tensioner and rotate the tensioner clockwise until the decal is aligned 15° on the tensioner tube.
 6. Insert the capscrew into the aligned guide holes and secure it with the nut (Figure 15).
- Note:** If holes are not exactly aligned, rotate the guide to the next higher hole until it is aligned.
7. Tighten the capscrew on the rear of the frame to lock the tensioner.
 8. Install the belt guard to the blower housing with the capscrews, washers, and nuts.

Storage

1. Thoroughly clean the blower.

Note: The fan housing should be free of dirt, leaves, and debris.

2. Lubricate all grease fittings. Wipe off any excess lubricant.
3. Place a light coat of grease on the splines of the PTO shaft.
4. Tighten all fasteners.

Troubleshooting

Problem	Possible Cause	Corrective Action
There is excessive vibration.	<ol style="list-style-type: none">1. The bearing(s) on the fan shaft is damaged.2. Material is built up on the fan blades.3. The engine speed of the PTO shaft is too fast.	<ol style="list-style-type: none">1. Replace the bearings.2. Clean out any build up on the inside of the housing.3. Reduce the PTO speed to 540 rpm.
There is lack of adequate air flow.	<ol style="list-style-type: none">1. The air slots are clogged with debris.2. The engine speed on the tractor is too slow.3. The throttle on the tractor engine is too slow.	<ol style="list-style-type: none">1. Clean out any debris from the slots.2. Increase the PTO speed to 540 rpm.3. Make any necessary repairs to bring the tractor speed up to normal.

Notes:

EEA/UK Privacy Notice

Toro's Use of Your Personal Information

The Toro Company ("Toro") respects your privacy. When you purchase our products, we may collect certain personal information about you, either directly from you or through your local Toro company or dealer. Toro uses this information to fulfil contractual obligations - such as to register your warranty, process your warranty claim or to contact you in the event of a product recall - and for legitimate business purposes - such as to gauge customer satisfaction, improve our products or provide you with product information which may be of interest. Toro may share your information with our subsidiaries, affiliates, dealers or other business partners in connection these activities. We may also disclose personal information when required by law or in connection with the sale, purchase or merger of a business. We will never sell your personal information to any other company for marketing purposes.

Retention of your Personal Information

Toro will keep your personal information as long as it is relevant for the above purposes and in accordance with legal requirements. For more information about applicable retention periods please contact legal@toro.com.

Toro's Commitment to Security

Your personal information may be processed in the US or another country which may have less strict data protection laws than your country of residence. Whenever we transfer your information outside of your country of residence, we will take legally required steps to ensure that appropriate safeguards are in place to protect your information and to make sure it is treated securely.

Access and Correction

You may have the right to correct or review your personal data, or object to or restrict the processing of your data. To do so, please contact us by email at legal@toro.com. If you have concerns about the way in which Toro has handled your information, we encourage you to raise this directly with us. Please note that European residents have the right to complain to your Data Protection Authority.

California Proposition 65 Warning Information

What is this warning?

You may see a product for sale that has a warning label like the following:



WARNING: Cancer and Reproductive Harm—www.p65Warnings.ca.gov.

What is Prop 65?

Prop 65 applies to any company operating in California, selling products in California, or manufacturing products that may be sold in or brought into California. It mandates that the Governor of California maintain and publish a list of chemicals known to cause cancer, birth defects, and/or other reproductive harm. The list, which is updated annually, includes hundreds of chemicals found in many everyday items. The purpose of Prop 65 is to inform the public about exposure to these chemicals.

Prop 65 does not ban the sale of products containing these chemicals but instead requires warnings on any product, product packaging, or literature with the product. Moreover, a Prop 65 warning does not mean that a product is in violation of any product safety standards or requirements. In fact, the California government has clarified that a Prop 65 warning "is not the same as a regulatory decision that a product is 'safe' or 'unsafe.'" Many of these chemicals have been used in everyday products for years without documented harm. For more information, go to <https://oag.ca.gov/prop65/faqs-view-all>.

A Prop 65 warning means that a company has either (1) evaluated the exposure and has concluded that it exceeds the "no significant risk level"; or (2) has chosen to provide a warning based on its understanding about the presence of a listed chemical without attempting to evaluate the exposure.

Does this law apply everywhere?

Prop 65 warnings are required under California law only. These warnings are seen throughout California in a wide range of settings, including but not limited to restaurants, grocery stores, hotels, schools, and hospitals, and on a wide variety of products. Additionally, some online and mail order retailers provide Prop 65 warnings on their websites or in catalogs.

How do the California warnings compare to federal limits?

Prop 65 standards are often more stringent than federal and international standards. There are various substances that require a Prop 65 warning at levels that are far lower than federal action limits. For example, the Prop 65 standard for warnings for lead is 0.5 µg/day, which is well below the federal and international standards.

Why don't all similar products carry the warning?

- Products sold in California require Prop 65 labelling while similar products sold elsewhere do not.
- A company involved in a Prop 65 lawsuit reaching a settlement may be required to use Prop 65 warnings for its products, but other companies making similar products may have no such requirement.
- The enforcement of Prop 65 is inconsistent.
- Companies may elect not to provide warnings because they conclude that they are not required to do so under Prop 65; a lack of warnings for a product does not mean that the product is free of listed chemicals at similar levels.

Why does Toro include this warning?

Toro has chosen to provide consumers with as much information as possible so that they can make informed decisions about the products they buy and use. Toro provides warnings in certain cases based on its knowledge of the presence of one or more listed chemicals without evaluating the level of exposure, as not all the listed chemicals provide exposure limit requirements. While the exposure from Toro products may be negligible or well within the "no significant risk" range, out of an abundance of caution, Toro has elected to provide the Prop 65 warnings. Moreover, if Toro does not provide these warnings, it could be sued by the State of California or by private parties seeking to enforce Prop 65 and subject to substantial penalties.



The Toro Warranty

Two-Year or 1,500 Hours Limited Warranty

Conditions and Products Covered

The Toro Company and its affiliate, Toro Warranty Company, pursuant to an agreement between them, jointly warrant your Toro Commercial product ("Product") to be free from defects in materials or workmanship for 2 years or 1,500 operational hours*, whichever occurs first. This warranty is applicable to all products with the exception of Aerators (refer to separate warranty statements for these products). Where a warrantable condition exists, we will repair the Product at no cost to you including diagnostics, labor, parts, and transportation. This warranty begins on the date the Product is delivered to the original retail purchaser.

* Product equipped with an hour meter.

Instructions for Obtaining Warranty Service

You are responsible for notifying the Commercial Products Distributor or Authorized Commercial Products Dealer from whom you purchased the Product as soon as you believe a warrantable condition exists. If you need help locating a Commercial Products Distributor or Authorized Dealer, or if you have questions regarding your warranty rights or responsibilities, you may contact us at:

Toro Commercial Products Service Department
Toro Warranty Company
8111 Lyndale Avenue South
Bloomington, MN 55420-1196

952-888-8801 or 800-952-2740
E-mail: commercial.warranty@toro.com

Owner Responsibilities

As the product owner, you are responsible for required maintenance and adjustments stated in your *Operator's Manual*. Repairs for product issues caused by failure to perform required maintenance and adjustments are not covered under this warranty.

Items and Conditions Not Covered

Not all product failures or malfunctions that occur during the warranty period are defects in materials or workmanship. This warranty does not cover the following:

- Product failures which result from the use of non-Toro replacement parts, or from installation and use of add-on, or modified non-Toro branded accessories and products.
- Product failures which result from failure to perform recommended maintenance and/or adjustments.
- Product failures which result from operating the Product in an abusive, negligent, or reckless manner.
- Parts consumed through use that are not defective. Examples of parts which are consumed, or used up, during normal Product operation include, but are not limited to, brake pads and linings, clutch linings, blades, reels, rollers and bearings (sealed or greasable), bed knives, spark plugs, castor wheels and bearings, tires, filters, belts, and certain sprayer components such as diaphragms, nozzles, and check valves.
- Failures caused by outside influence, including, but not limited to, weather, storage practices, contamination, use of unapproved fuels, coolants, lubricants, additives, fertilizers, water, or chemicals.

Countries Other than the United States or Canada

Customers who have purchased Toro products exported from the United States or Canada should contact their Toro Distributor (Dealer) to obtain guarantee policies for your country, province, or state. If for any reason you are dissatisfied with your Distributor's service or have difficulty obtaining guarantee information, contact your Authorized Toro Service Center.

- Failure or performance issues due to the use of fuels (e.g. gasoline, diesel, or biodiesel) that do not conform to their respective industry standards.
- Normal noise, vibration, wear and tear, and deterioration. Normal "wear and tear" includes, but is not limited to, damage to seats due to wear or abrasion, worn painted surfaces, scratched decals or windows.

Parts

Parts scheduled for replacement as required maintenance are warranted for the period of time up to the scheduled replacement time for that part. Parts replaced under this warranty are covered for the duration of the original product warranty and become the property of Toro. Toro will make the final decision whether to repair any existing part or assembly or replace it. Toro may use remanufactured parts for warranty repairs.

Deep Cycle and Lithium-Ion Battery Warranty

Deep cycle and Lithium-Ion batteries have a specified total number of kilowatt-hours they can deliver during their lifetime. Operating, recharging, and maintenance techniques can extend or reduce total battery life. As the batteries in this product are consumed, the amount of useful work between charging intervals will slowly decrease until the battery is completely worn out. Replacement of worn out batteries, due to normal consumption, is the responsibility of the product owner. Note: (Lithium-Ion battery only): Pro-rated after 2 years. Refer to the battery warranty for additional information.

Maintenance is at Owner's Expense

Engine tune-up, lubrication, cleaning and polishing, replacement of filters, coolant, and completing recommended maintenance are some of the normal services Toro products require that are at the owner's expense.

General Conditions

Repair by an Authorized Toro Distributor or Dealer is your sole remedy under this warranty.

Neither The Toro Company nor Toro Warranty Company is liable for indirect, incidental or consequential damages in connection with the use of the Toro Products covered by this warranty, including any cost or expense of providing substitute equipment or service during reasonable periods of malfunction or non-use pending completion of repairs under this warranty. Except for the Emissions warranty referenced below, if applicable, there is no other express warranty. All implied warranties of merchantability and fitness for use are limited to the duration of this express warranty.

Some states do not allow exclusions of incidental or consequential damages, or limitations on how long an implied warranty lasts, so the above exclusions and limitations may not apply to you. This warranty gives you specific legal rights, and you may also have other rights which vary from state to state.

Note Regarding Emissions Warranty

The Emissions Control System on your Product may be covered by a separate warranty meeting requirements established by the U.S. Environmental Protection Agency (EPA) and/or the California Air Resources Board (CARB). The hour limitations set forth above do not apply to the Emissions Control System Warranty. Refer to the Engine Emission Control Warranty Statement supplied with your product or contained in the engine manufacturer's documentation.



Count on it.