



**Mid-Size Mower**  
**Proline Gear with 44" Side Discharge Mower**  
Model No. 30259—21000001 and Up

## Parts Catalog

### Ordering Replacement Parts

To order replacement parts, please supply: the part number, the quantity, and the description of each part desired.

### Understanding Reference Numbers

Each identified part in an illustration has a reference number. The reference number for a part also appears in the parts list, along with other information about the part.

This catalog uses two special reference number formats, one to indicate parts in a service assembly and another to indicate the quantity of a given part in an illustration.

### Service Assembly Reference Numbers

Parts in service assemblies have reference numbers in the form **a:b**. The **a** represents the reference number of the entire service assembly and the **b** represents a sequential number unique to each part within the service assembly.

For example, a wheel assembly might be identified by reference number **6**, the tire by **6:1**, the valve by **6:2**, and the wheel by **6:3**. When you order the assembly identified by reference number **6**, you receive all parts identified by reference numbers **6:1**, **6:2**, and **6:3**. However, you may also order any part individually.

Reference numbers of this type appear in illustrations and in part lists.

### Reference Numbers Indicating Quantity

In an illustration, if a reference number indicates more than one part, the reference number has the form **nX y**. The **n** represents the quantity of the part, the **X** is the multiplication symbol, and the **y** represents the reference number.

For example, in an illustration, the reference number **2X 37** means that two of the parts identified by reference number **37** are indicated.

## Contents

<b>Description</b>	<b>Page</b>	<b>Description</b>	<b>Page</b>
Engine and Clutch Assembly .....	3	Valve/Camshaft Assembly .....	19
Clutch Assembly No. 54-3200 .....	4	Valve/Camshaft Assembly .....	20
Fuel Tank Assembly .....	5	Piston/Crankshaft Assembly .....	21
Lower Controls Assembly .....	6	Lubrication-Equipment Assembly .....	22
Transmission and Drive System Assembly .....	7	Cooling-Equipment Assembly .....	23
Wheel Drive and Brake System Assembly .....	8	Cooling-Equipment Assembly .....	24
Handle Assembly .....	9	Electric-Equipment Assembly .....	25
Control Panel Assembly .....	10	Electric-Equipment Assembly .....	26
Deck Assembly .....	11	Control-Equipment Assembly .....	27
Spindles, Idler Pulleys and Belts Assembly .....	12	Control-Equipment Assembly .....	28
Spindle Housing Assembly No. 104-6316 .....	13	Carburetor Assembly .....	29
Spindle Housing Assembly No. 104-6314 .....	14	Carburetor Assembly .....	30
Carrier Frame Assembly .....	15	Air-Filter/Muffler Assembly .....	31
Electrical Schematic .....	16	Fuel-Tank/Fuel-Valve Assembly .....	32
Cylinder/Crankcase Assembly .....	17	Starter .....	33
Cylinder/Crankcase Assembly .....	18	Starter/Decals .....	34

## Part Description Abbreviations

Part descriptions in this catalog may include the following abbreviations.

<b>Abbreviation</b>	<b>Meaning</b>	<b>Abbreviation</b>	<b>Meaning</b>
AR .....	as required	HYD .....	hydraulic
ASM .....	assembly	INC .....	incorporated
CARR .....	carriage	LH .....	left hand
DEG .....	degrees	NI .....	nylon insert
FH .....	flat head	PPH .....	Phillips pan head
GA .....	gauge	PTH .....	Phillips truss head
HF .....	hex flange	PTO .....	power take off
HH .....	hex head	RH .....	right hand
HHF .....	hex head flange	SFH .....	slotted fillister head
HLH .....	hex lag head	SHH .....	slotted hex head
HJ .....	hex jam	SQH .....	square head
HOC .....	height-of-cut	SHWH .....	slotted hex washer head
HS .....	hex socket	SPH .....	slotted pan head
HSBH .....	hex socket button head	SRH .....	slotted round head
HSFH .....	hex socket flat head	STD .....	standard
HSH .....	hex socket head	TAP .....	self tapping
HWH .....	hex washer head	TTH .....	Torx truss head
HWHTF .....	hex washer head thread forming	WH .....	wing head

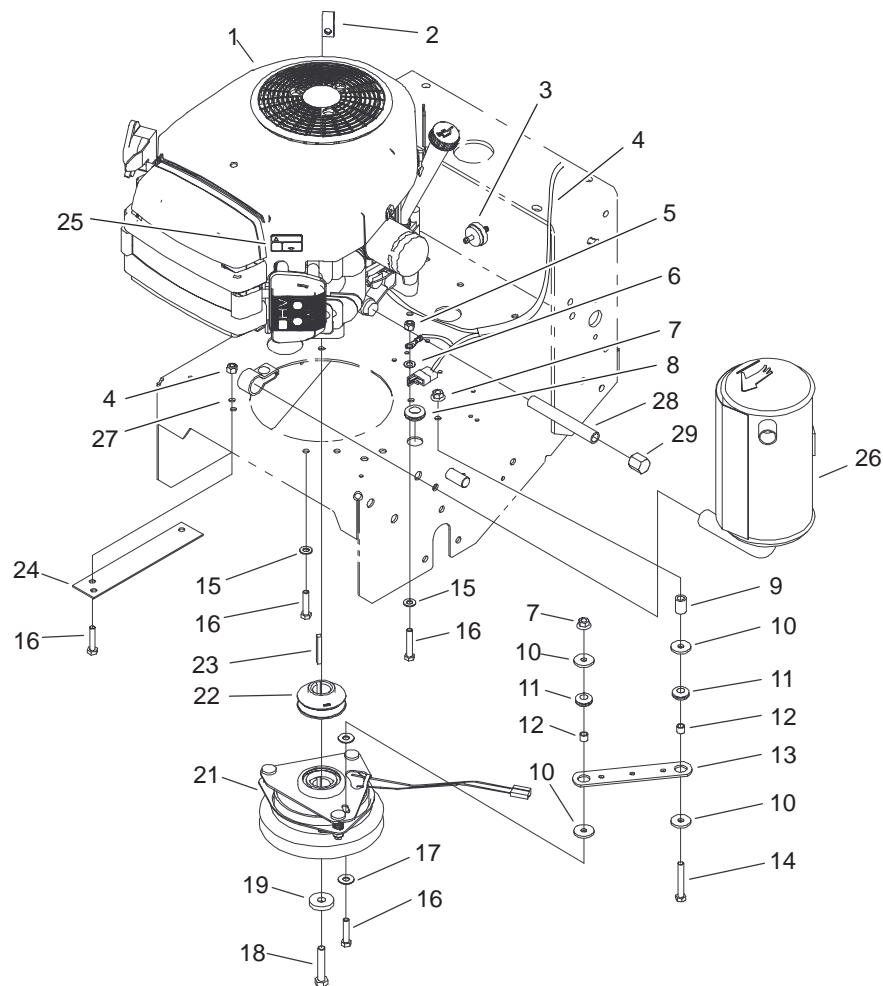

Sheet No.: 4

## Engine and Clutch Assembly

Ref. No.	Part No.	Qty.	Description	Ref. No.	Part No.	Qty.	Description
☆1		1	Engine-Kawasaki, FH500V-AS25	27	100-6468	1	Clamp-Muffler
2	2412-87	1	Clamp-Cable	28	289-19	1	Nipple
3	56-6360	1	Filter-Fuel	29	288-10	1	Cap-Pipe
4	104-8137	1	Wire Harness				
5	3296-29	4	Nut-Lock				
6	3255-8	1	Washer-Lock/Ext				
7	32128-20	2	Nut-HF				
8	237-124	1	Grommet				
9	104-6373	1	Tube - Retainer				
10	1-613235	4	Washer				
11	1-633630	2	Grommet-Brake				
12	1-633545	2	Spacer-Grommet				
13	1-633543	1	Strap,Clutch/Brake				
14	322-11	1	Screw-HH				
15	3256-23	2	Washer-Flat				
16	322-7	5	Screw-HH				
17	3256-3	2	Washer-Flat				
18	3212-9	1	Screw-HH				
19	112843	1	Washer				
21	54-3200	1	Clutch/Brake				
22	105-0827	1	Pulley-Drive				
23	608006	1	Key				
24	94-5847-01	1	Cover - Pulley				
25	63-8440	1	Decal-Hot Surface				
26	100-6467	1	Muffler				

☆ Not serviced

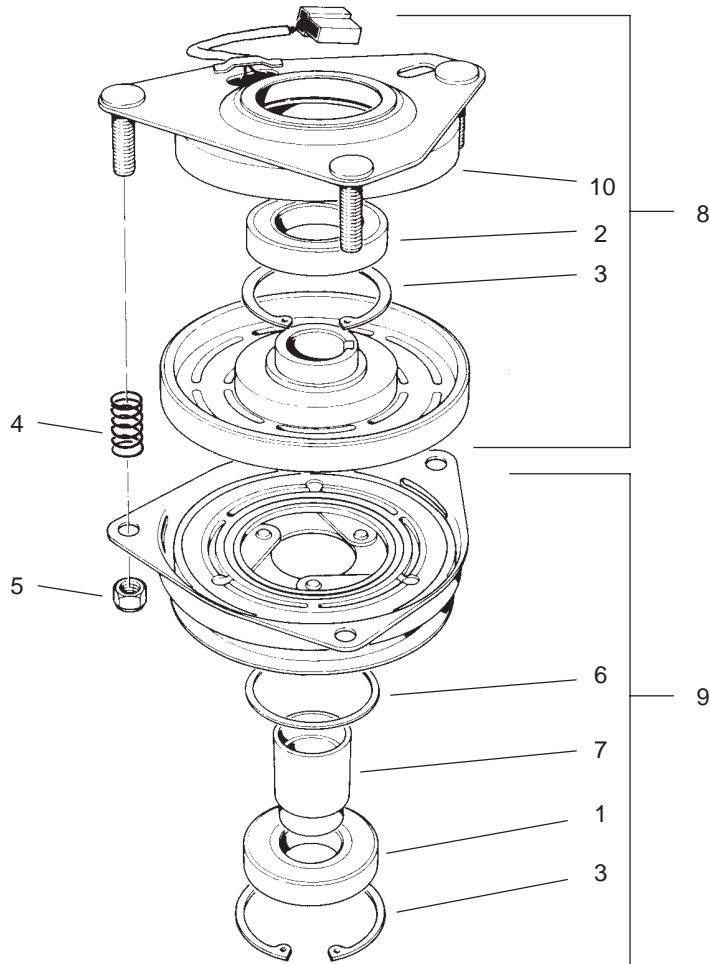

Sheet No.: A1  
T-3726

### Clutch Assembly No. 54-3200

Ref. No.	Part No.	Qty.	Description
1	251-291	1	Bearing-Pulley
2	251-292	1	Bearing-Field
3	44-8310	2	Ring-Retaining
4	44-8320	3	Spring
5	3296-6	3	Nut-Lock, NI
6	44-8330	1	Spacer-Pulley Bearing
7	44-8340	1	Collar-Bearing
8	44-8360	1	Field Coil-Rotor / Bearing ASM
9	44-8370	1	Armature / Pulley / Bearing ASM
10	54-0230	1	Field Bearing ASM

Ref. No.	Part No.	Qty.	Description

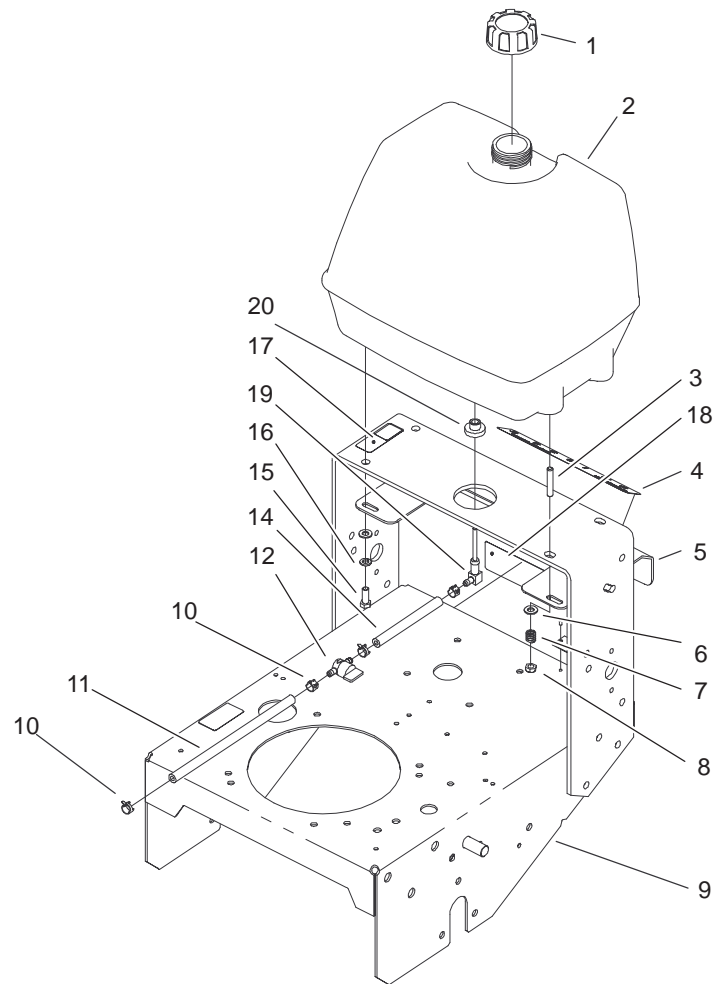

Sheet No.: 5

## Fuel Tank Assembly

Ref. No.	Part No.	Qty.	Description
1	55-3570	1	Gas Cap ASM
2	1-323551	1	Tank-Fuel
3	104-8121	2	Stud-Threaded
4	98-3256	1	Decal-Ground Speed
5	104-8102-01	1	Plate-Shift Gate
6	3256-23	4	Washer-Flat
7	1-633349	2	Spring-Tank, Fuel
8	3296-47	2	Nut-Lock, NI
9	104-8100-01	1	Traction Frame ASM
10	2412-98	4	Clamp
11	47-2982	1	Hose-Gas
12	1-603770	1	Valve-Fuel
14	47-2980	1	Hose-Gas
15	322-4	2	Screw-HH
16	3253-4	2	Washer-Lock
17	95-2814	1	Decal-Fuel Shut Off
18	98-0776	1	Decal-Caution
19	1-543277	1	Elbow-Tank, Fuel
20	1-513645	1	Bushing-Valve, Fuel

Ref. No.	Part No.	Qty.	Description



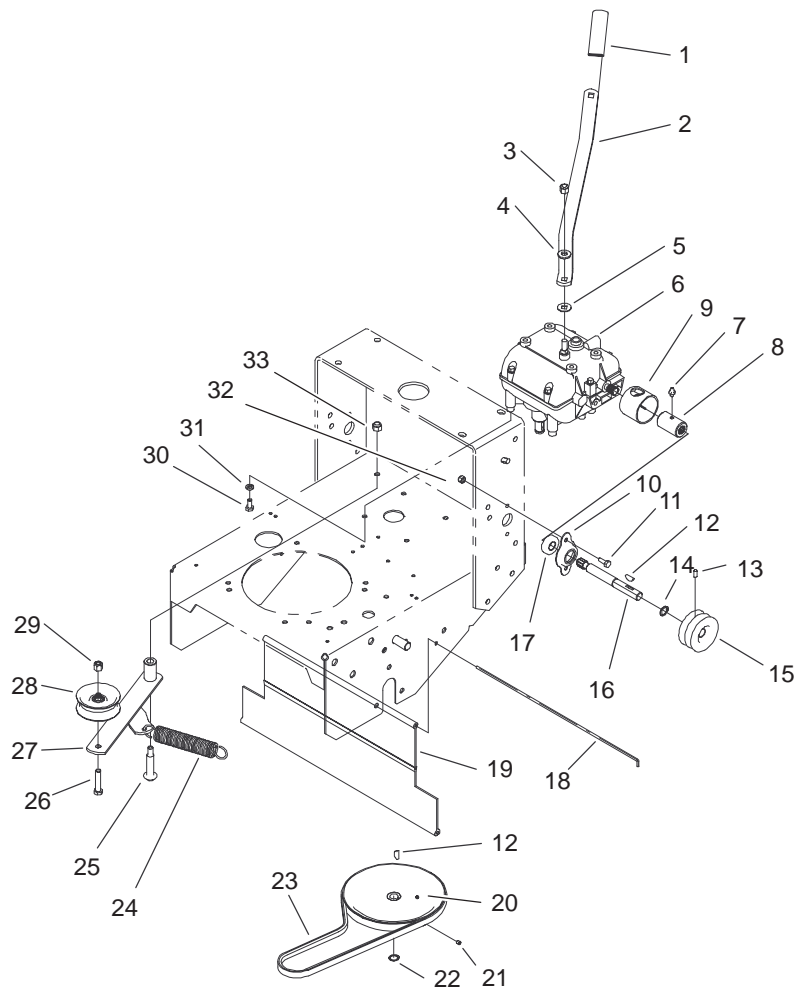

Sheet No.: 7

## Transmission and Drive System Assembly

Ref. No.	Part No.	Qty.	Description	Ref. No.	Part No.	Qty.	Description
1	47-1970	1	Grip-Engagement	26	323-9	1	Screw-HH
2	98-3274-03	1	Lever-Shift	27	16-7509	1	Lever-Idler
3	3296-6	1	Nut-Lock, NI	28	62-4540	1	Pulley
4	98-5975	1	Washer-Belleville	29	3296-39	1	Nut-Lock, NI
5	1-323379	1	Washer-Shifter Lever	30	322-2	4	Screw-HH
6	1-323500	1	Transmission, Peerless	31	3253-4	4	Washer-Lock
7	302-5	2	Fitting-Grease	32	3296-42	4	Nut-Lock, NI
8	98-0789	2	Coupler	33	3296-6	1	Nut-Lock, NI
9	51-4220	2	Guard-Coupler				
10	1-323254	2	Flange-Output				
11	321-4	4	Screw-HH				
12	3257-5	3	Key-Woodruff				
13	3245-9	2	Screw-Set				
14	32151-62	2	Ring-Retaining				
15	105-0828	2	Pulley-Transmission				
16	104-1102	2	Shaft-Output				
17	1-323252	2	Bearing-Shaft, Transmission				
18	95-1529	1	Rod-Shield				
19	95-1526	1	Shield-Trailing				
20	51-4190	1	Pulley-Driven				
21	3245-1	1	Screw-Set, HSH				
22	32120-64	1	Ring-Snap, External				
23	26-9671	1	V-Belt				
24	68-2190	1	Spring-Extension				
25	27-6230	1	Bolt-Wheel				

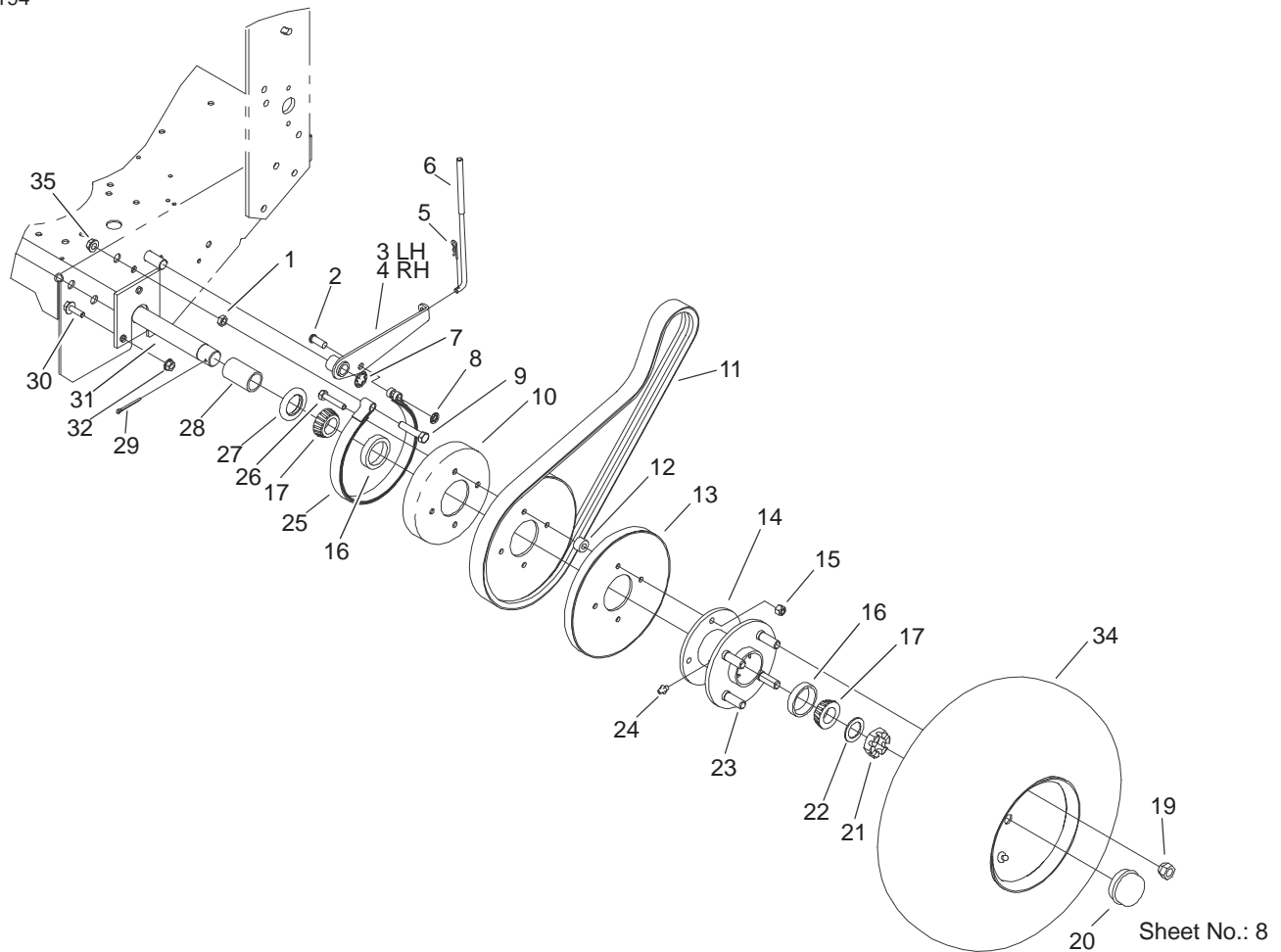

## Wheel Drive and Brake System Assembly

Ref. No.	Part No.	Qty.	Description
1	3218-3	2	Nut-Jam
2	1-323307	2	Pin - Clevis
3	51-4610-01	1	Arm-LH Brake
4	51-4600-01	1	Arm-RH Brake
5	3290-307	2	Pin-Hair
6	51-4580	2	Rod-Brake
7	32151-40	2	Ring-Retaining
8	32151-56	2	Ring-Retaining, Ext
9	323-9	2	Screw-HH
10	1-323261	2	Drum, Brake
11	104-8152	2	Belt-Traction Drive
12	51-4170	8	Spacer-Pulley
13	51-4160-03	4	Pulley-Wheel
14	1-413333	2	Hub, Wheel W/Cups
15	3296-29	8	Nut-Lock
16	254-72	4	Bearing-Taper/Cup
17	254-94	4	Bearing-Taper/Cone
19	242-50	8	Nut-Lug
20	241-119	2	Cap-Dust
21	1-809082	2	Nut, SHH
22	1-523157	2	Washer-Spacer
23	1-633926	8	Stud-Wheel
24	302-19	2	Fitting-Grease
25	1-323262	2	Band, Brake
26	322-8	8	Screw-HH
27	1-543511	2	Seal-Grease

Ref. No.	Part No.	Qty.	Description
28	104-1197	2	Spacer-Wheel
29	1-806800	2	Pin-Cotter
30	3234-11	6	Screw-HHF
31	104-1196-01	1	Axle ASM
32	32128-21	6	Nut-HF
34	104-1198	2	Wheel And Tire ASM
35	3290-357	2	Nut-Flange, Lock





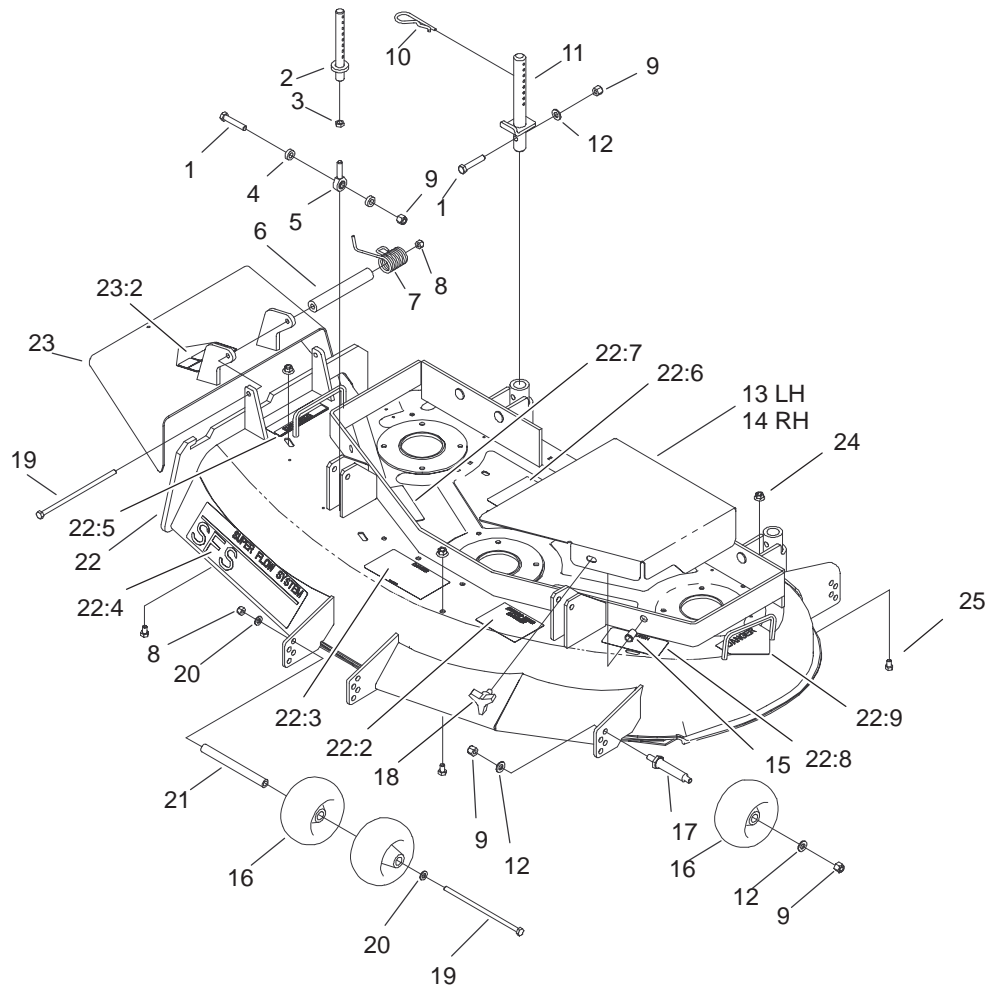

Sheet No.: 2

## Deck Assembly

Ref. No.	Part No.	Qty.	Description	Ref. No.	Part No.	Qty.	Description
1	323-10	4	Screw-HH	22:5	104-8569	1	Decal-Deflector Warning
2	105-0832	2	Link-Support	22:6	104-8186	1	Decal-Belt Routing
3	3220-3	2	Nut-Jam	22:7	67-5360	3	Decal-Danger
4	104-1156	4	Spacer	22:8	68-8340	1	Decal-Torque
5	1-613204	2	Balljoint	22:9	43-8480	1	Decal-Danger
6	104-8555	1	Spacer-Mounting, Deflector	23	104-7783	1	Deflector ASM
7	104-8554	1	Spring-Torsion	23:2	54-9220	1	Decal-Danger
8	3296-29	2	Nut-Lock	24	32128-20	3	Nut-HF
9	3296-39	8	Nut-Lock, NI	25	322-1	3	Screw-HH
10	3290-256	6	Pin-Hair				
11	105-0831	2	Rod ASM				
12	3256-24	6	Washer-Flat				
13	104-8117-01	1	Cover-Belt,Left				
14	104-8118-01	1	Cover-Belt,Right				
15	32148-10	2	Insert-Threaded				
16	68-2730	4	Gage-Wheel				
17	99-2842	2	Spacer-Wheel				
18	104-8587	2	Knob				
19	322-50	2	Screw-Cap				
20	3256-23	2	Washer-Flat				
21	98-5967	1	Spacer - Wheel				
22	104-6392	1	44" Deck ASM				
22:2	105-0840	1	Decal-Anti Scalp				
22:3	66-1340	1	Decal-Danger				
22:4	98-8028	1	Decal-Sfs 44"				

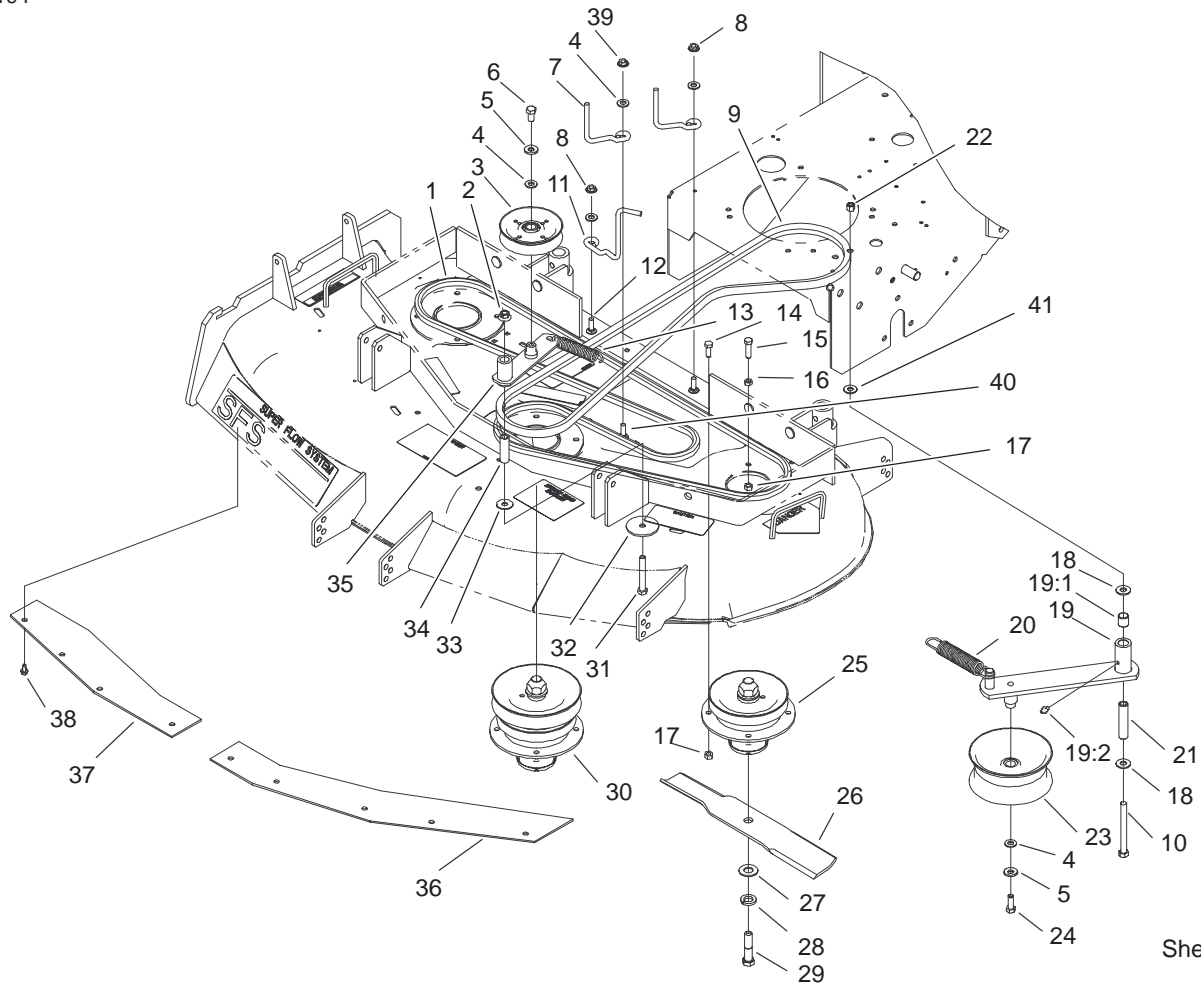

Sheet No.: 3

## Spindles, Idler Pulleys and Belts Assembly

Ref. No.	Part No.	Qty.	Description
1	27-1160	1	V-Belt, Deck
2	32128-19	1	Nut-HF
3	65-5940	1	Pulley-Idler
4	3256-24	5	Washer-Flat
5	98-5975	2	Washer-Belleville
6	323-4	1	Screw-HH
7	52-4780	2	Rod-Belt
8	32128-13	2	Nut-HF
9	104-8120	1	V-Belt, PTO
10	323-42	1	Screw-HH
11	105-0852	1	Guide-Belt
12	3230-2	2	Screw-CARR
13	54-2730-03	1	Spring-Extension
14	322-4	11	Screw-HH
15	322-6	1	Screw-HH
16	3218-2	1	Nut-Jam
17	32152-1	12	Nut-Lock, NI
18	1-809107	2	Washer-Hardened
19	104-6370	1	Idler Arm ASM
19:1	1-513034	2	Sleeve-Bearing
19:2	302-5	1	Fitting-Grease
20	104-8161	1	Spring-Extension
21	104-6377	1	Tube - Idler
22	3296-39	1	Nut-Lock, NI
23	1-413099	1	Pulley-Idler
24	323-6	1	Screw-HH

Ref. No.	Part No.	Qty.	Description
25	104-6316	2	Spindle Housing ASM
26	54-0010	3	Blade
27	3256-27	3	Washer-Flat
28	3253-8	3	Washer-Lock
29	51-4060	3	Screw-Blade
30	104-6314	1	Spindle Housing ASM
31	323-13	1	Screw-HH
32	20-9530	1	Washer-End
33	52-2860	1	Washer
34	104-8113	1	Tube-Idler
35	104-8110	1	Idler Arm ASM
36	100-3258-03	1	Plate-Blowout, LH
37	100-3257-03	1	Plate-Blowout, RH
38	12-3270	9	Screw
39	32128-32	1	Nut-HHF
40	3229-4	1	Screw-CARR
41	3256-4	1	Washer-Flat

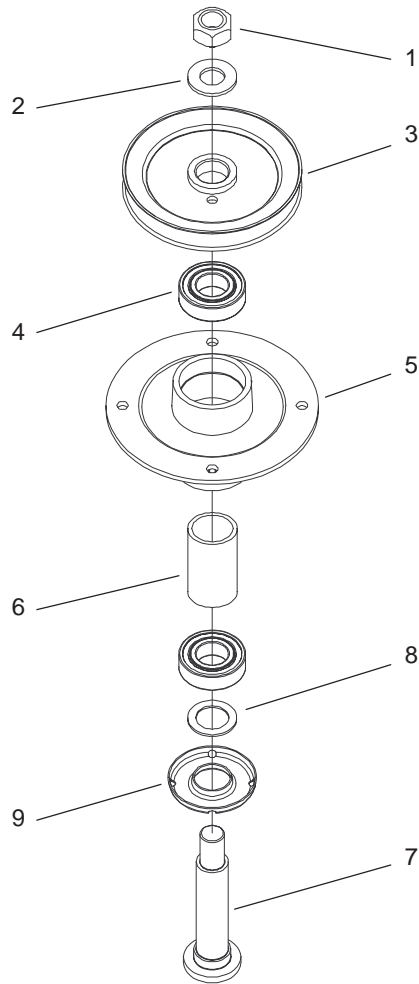

Sheet No.: A1  
C\_3014

## Spindle Housing Assembly No. 104-6316

Ref. No.	Part No.	Qty.	Description	Ref. No.	Part No.	Qty.	Description
1	3219-7	1	Nut-Hex				
2	7-4150	1	Washer-Pinion				
3	104-1181	1	Pulley ASM				
4	104-6325	2	Bearing				
5	67-7590	1	Housing-Spindle				
6	104-6312	1	Spacer-Bearing				
7	104-8193	1	Shaft-Spindle				
8	88-7540	1	Washer - Backup				
9	79-1920	1	Shield-Bearing				

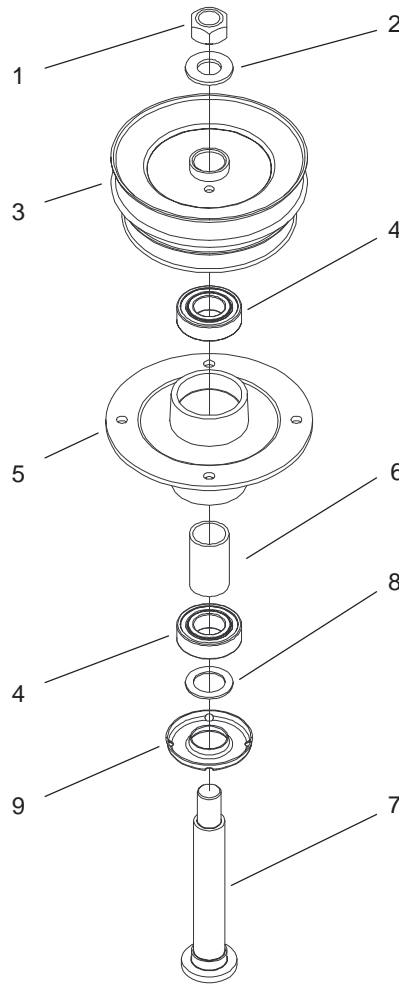

Sheet No.: A2  
C-3013

## Spindle Housing Assembly No. 104-6314

Ref. No.	Part No.	Qty.	Description
1	3219-7	1	Nut-Hex
2	7-4150	1	Washer-Pinion
3	104-1116	1	Pulley And Hub ASM
4	104-6325	2	Bearing
5	67-7590	1	Housing-Spindle
6	104-6312	1	Spacer-Bearing
7	104-8194	1	Shaft-Spindle
8	88-7540	1	Washer - Backup
9	79-1920	1	Shield-Bearing

Ref. No.	Part No.	Qty.	Description

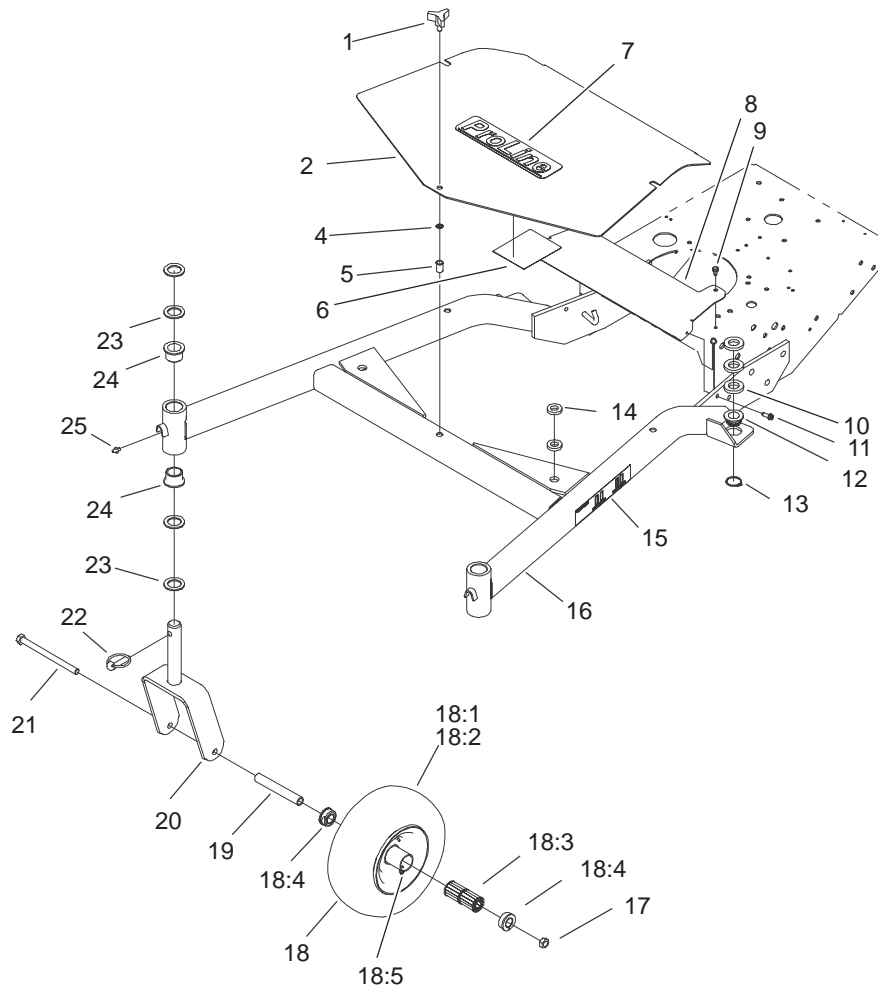

Sheet No.: 4

## Carrier Frame Assembly

Ref. No.	Part No.	Qty.	Description
1	104-8587	3	Knob
2	104-8153-01	1	Cover-Carrier Frame
4	32151-72	1	Ring-Retaining
5	32148-9	3	Nut-Insert
6	104-8173	1	Decal-Service, Hydro
6	104-8175	1	Decal-Service, Gear
7	74-2080	1	Decal-Proline
8	105-0845-01	1	Shield-Heat
9	12-3270	2	Screw
10	104-1105	6	Spacer-Deck Support
11	49-2040	2	Screw-Tapping
12	1-513336	2	Bushing - Deck
13	32120-33	2	Ring-Retaining
14	105-0842	4	Spacer
15	104-8171	2	Decal-HOC
16	104-1109-01	1	Carrier Frame ASM
17	32153-5	2	Nut-Lock
18	104-1170	2	Castor Wheel ASM
18:1	104-1169	1	Tire And Tube ASM
18:2	105-0844	1	Tube-Inner
18:3	62-5570	2	Bearing-Roller
18:4	62-5580	2	Bearing-Outside
18:5	302-11	1	Fitting-Lube, 45°
19	104-1189	2	Bushing-Spanner
20	104-1183-01	2	Castor Fork ASM
21	325-33	2	Screw-HH

Ref. No.	Part No.	Qty.	Description
22	283-71	2	Pin-Lynch
23	3-6781	8	Washer-Thrust
24	94-1291	4	Bushing-Special
25	302-5	2	Fitting-Grease

# Electrical Schematic

CABLE/WIRE LIST INFORMATION FOR DIAGRAM

104-8137-

Name	SPOOL	NAME	COLOR	Component	Pin	TERMINAL			TERMINAL				
						MFG	PARTNUM	SEAL	MFG	PARTNUM	SEAL		
W1		GPT16PK	PINK	P3	2	PACKARD	12089950	-	P6	4	PACKARD	02965891	-
W4		GPT16BK	BLACK	P1	1	PACKARD	12041129	-	P4	2	PACKARD	02965467	-
W5		GPT18BK	BLACK	P4	2	PACKARD	02965467	-	P5	4	PACKARD	02965510	-
W6		GPT16GN	GREEN	P5	3	PACKARD	02965867	-	P1	2	PACKARD	02971962	-
W8		GPT16PK	PINK	P6	4	PACKARD	02965891	-	P5	2	PACKARD	02965867	-
W10		GPT18BN	BROWN	J4	1	PACKARD	02965141	-	J5	1	ESSEX	541617-82	-
W11		GPT18OR	ORANGE	P5	1	PACKARD	02977112	-	J3	1	PACKARD	02965141	-
W12		GPT18OR	ORANGE	P5	1	PACKARD	02977112	-	P6	1	PACKARD	02965510	-
W13		GPT16BK	BLACK	P1	1	PACKARD	12041129	-	J1	1	ESSEX	101634-C02	-
W14		GPT16PK	PINK	P3	1	PACKARD	12089950	-	J8	1	AMP	3-520106-2	-
W15		GPT16W	WHITE	J7	1	ESSEX	521616-A02	-	P4	1	PACKARD	02965462	-
W16		GPT18BK	BLACK	P5	4	PACKARD	02965510	-	J2	1	ESSEX	521618-B2	-

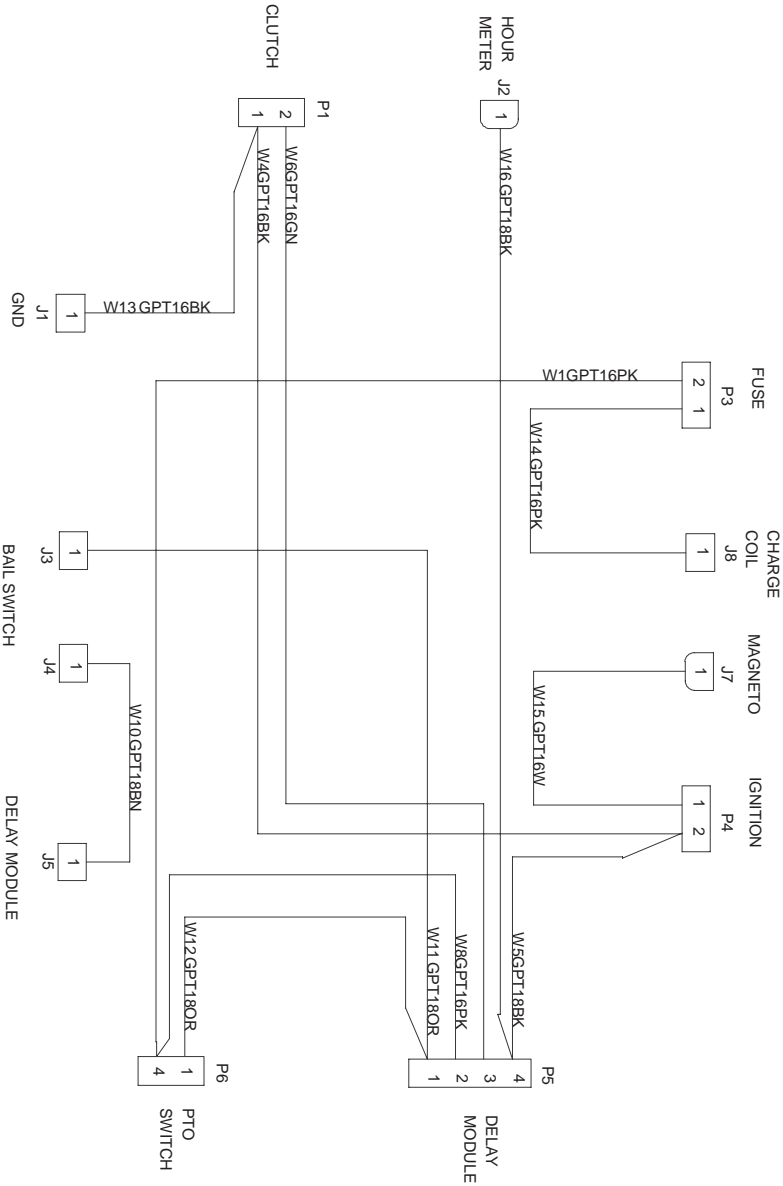

# Cylinder/Crankcase Assembly Kawasaki FH500V-AS25

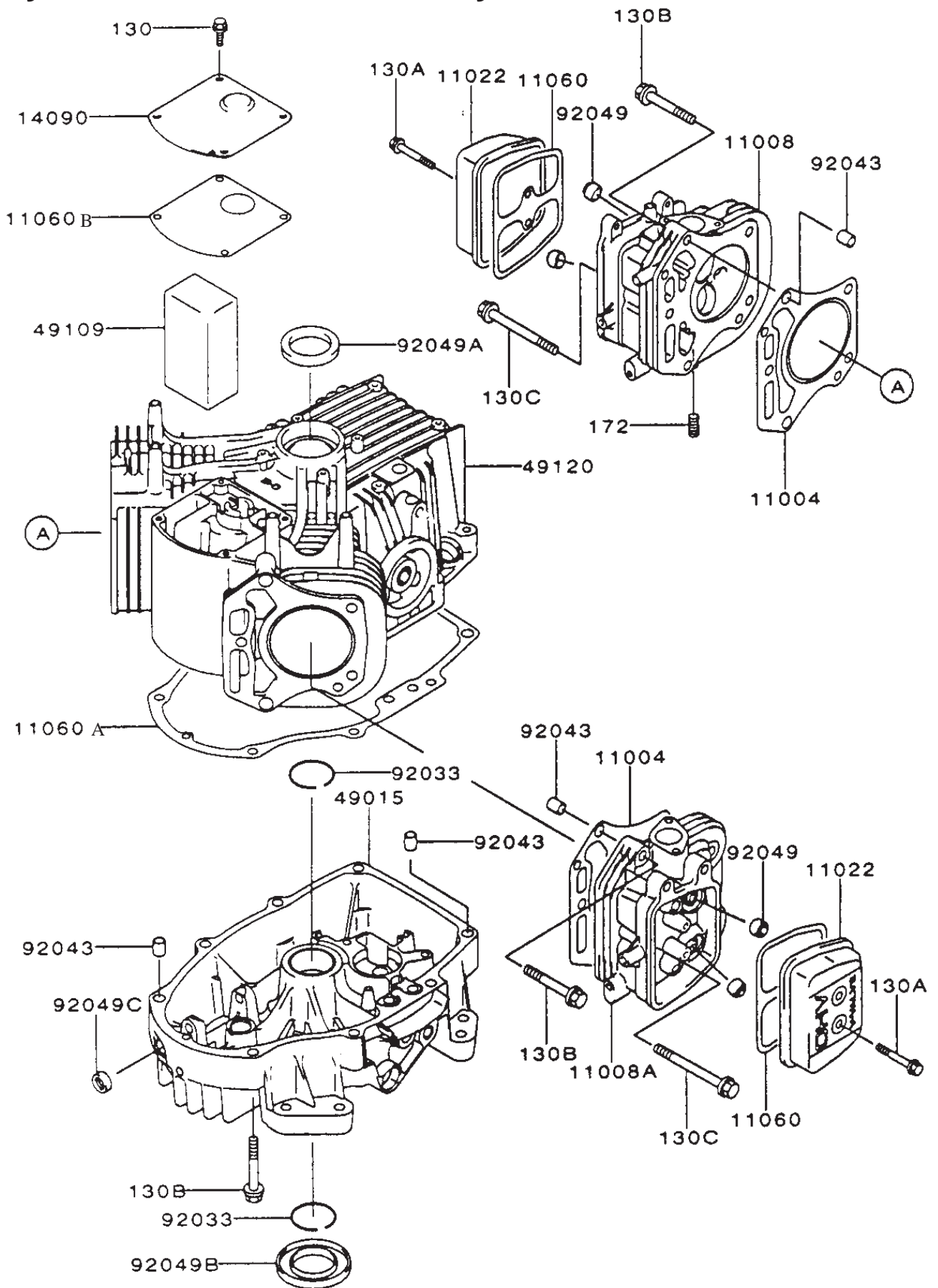

# Cylinder/Crankcase Assembly Kawasaki FH500V-AS25

Ref. No.	Part No.	Qty.	Description
11004	11004-7001	2	Gasket-Head
11008	11008-7001	1	Head-Comp-Cylinder No. 1
11008A	11008-7002	1	Head-Comp-Cylinder No. 2
11022	11022-7001	2	Case-Rocker
11060	11060-7001	2	Gasket, Rocker Case
11060A	11060-7008	1	Gasket, Crankcase Cover
11060B	11060-7015	1	Gasket, Breather
14090	14090-7001	1	Cover, Breather
49015	49015-6215	1	Cover-Crankcase
49109	49109-7002	1	Element-Breather
49120	49120-6119	1	Crankcase-Comp
92033	92033-7003	2	Ring-Snap
92043	92043-7001	6	Pin
92049	92049-7001	4	Seal-Oil
92049A	92049-7002	1	Seal-Oil
92049B	92049-7004	1	Seal-Oil
92049C	92049-7005	1	Seal-Oil
130	130B0612	4	Bolt-Flanged
130A	130B0640	4	Bolt-Flanged
130B	130T0850	17	Bolt-Flanged
130C	130T0875	2	Bolt-Flanged
172	172G0818	4	Bolt-Stud

Ref. No.	Part No.	Qty.	Description



# Valve/Camshaft Assembly Kawasaki FH500V-AS25

Ref. No.	Part No.	Qty.	Description
12004	12004-7001	2	Valve-Intake
12005	12005-7001	2	Valve-Exhaust
12009	12009-7001	4	Retainer-Valve Spring
12011	12011-2056	8	Collet
12016	12016-7001	4	Arm-Rocker
12032	12032-7001	4	Tappet
13070	13070-7001	2	Guide
13070A	13070-7002	1	Guide
13116	13116-2057	4	Rod-Push
13270	13270-7002	1	Plate
13270A	13270-7003	1	Plate
42036	42036-7001	1	Sleeve
49078	49078-7001	4	Spring-Engine Valve
49118	49118-7002	1	Camshaft-Comp
92009	92009-2341	4	Screw
92015	92015-2253	4	Nut
92033	92033-7001	2	Ring-Snap
92140	92140-7002	6	Ball
92145	92145-7001	1	Spring
92151	92151-7001	4	Bolt
92200	92200-7001	1	Washer

Ref. No.	Part No.	Qty.	Description





# Cooling-Equipment Assembly Kawasaki FH500V-AS25

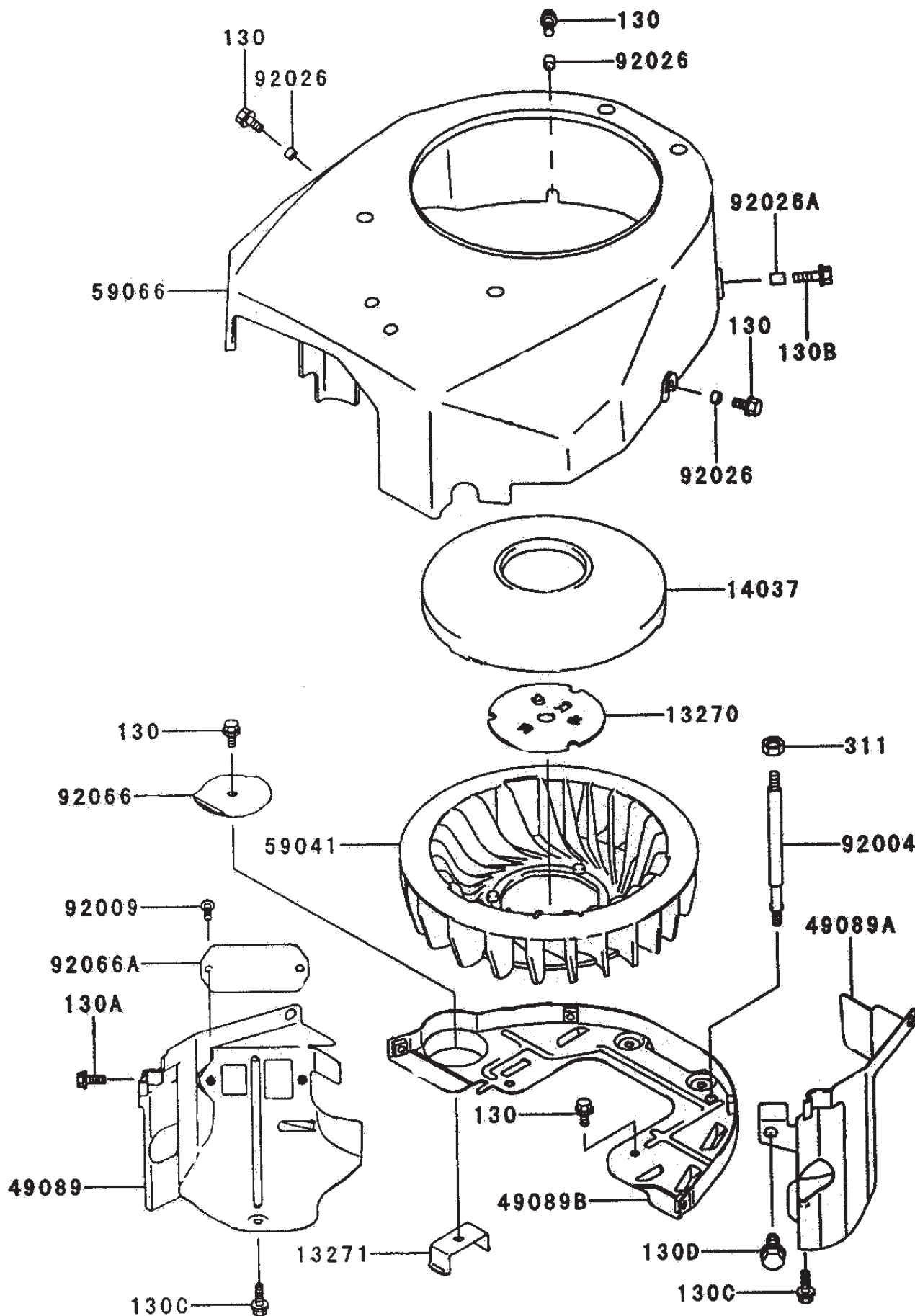

# Cooling-Equipment Assembly Kawasaki FH500V-AS25

Ref. No.	Part No.	Qty.	Description
130	130B0612	6	Bolt-Flanged
130A	130B0616	2	Bolt-Flanged
130B	130B0620	1	Bolt-Flanged
130C	130B0625	2	Bolt-Flanged
130D	130B0816	1	Bolt-Flanged
13270	13270-7007	1	Plate
13271	13271-7002	1	Plate
14037	14037-7002	1	Screen
311	311B0600	2	Nut-Hex
49089	49089-7001	1	Shroud-Engine
49089A	49089-7002	1	Shroud-Engine
49089B	49089-7003	1	Shroud-Engine
59041	59041-7001	1	Fan
59066	59066-7002	1	Housing-Fan
92004	92004-7006	2	Stud
92009	92009-2308	2	Screw
92026	92026-7001	3	Spacer, 6.2x7.9x5
92026A	92026-7003	1	Spacer, 6.5x7.9x10.5
92066	92066-7004	1	Plug
92066A	92066-7004	1	Plug

Ref. No.	Part No.	Qty.	Description

# Electric-Equipment Assembly Kawasaki FH500V-AS25 3325-194

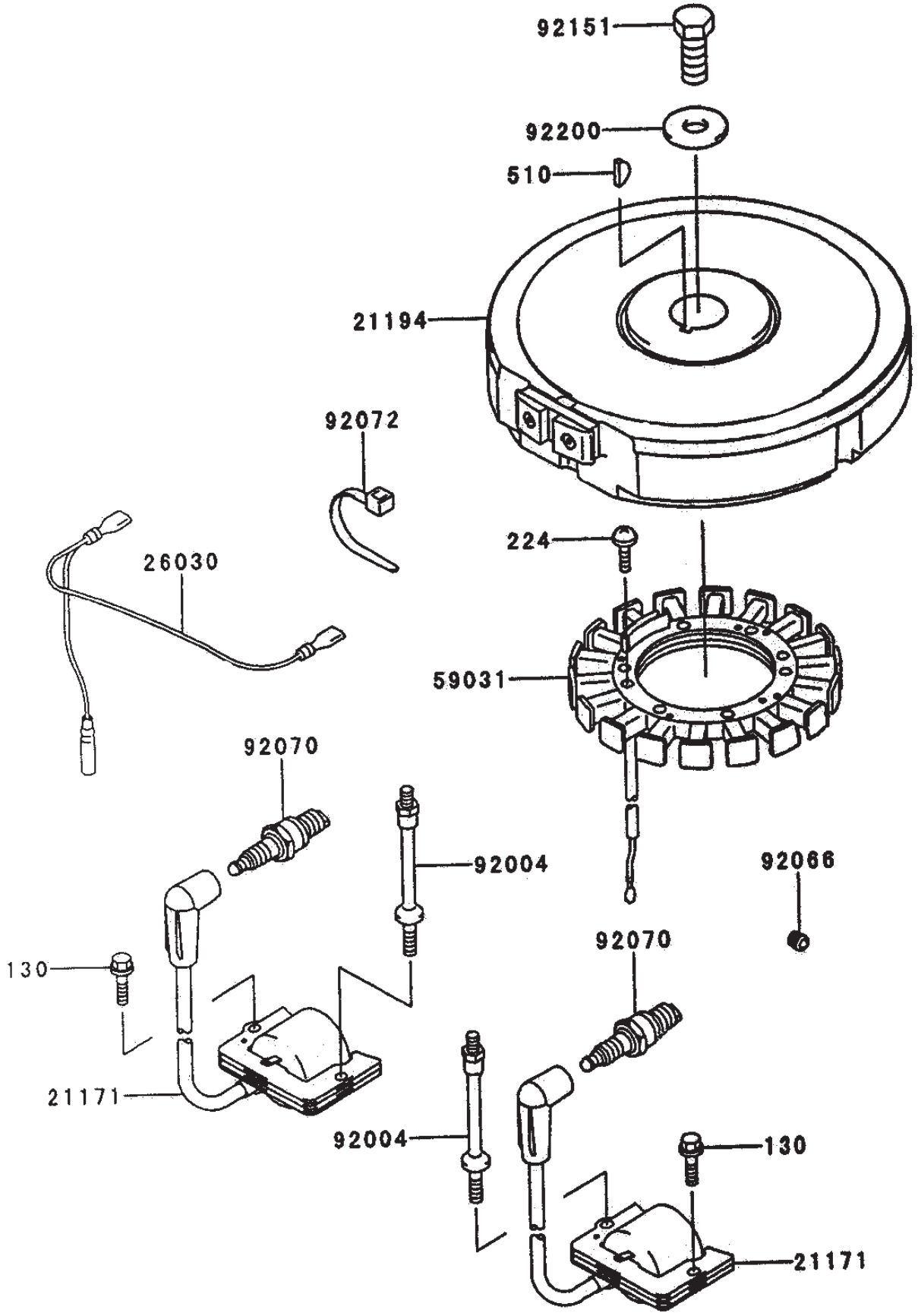

# Electric-Equipment Assembly Kawasaki FH500V-AS25

Ref. No.	Part No.	Qty.	Description
21171	21171-7001	2	Coil-Assy-Ignition
21194	21193-7001	1	Flywheel-Assy
26030	26030-7001	1	Harness
59031	59031-7002	1	Coil-Charging
92004	92004-2147	2	Stud
92066	92066-7002	1	Plug
92070	92070-7001	2	Plug-Spark (RCJ8Y)
92072	92072-7001	2	Band
92151	92151-2097	1	Bolt, 12x30
92220	92220-7002	1	Washer
130	130B0620	2	Bolt-Flanged
224	224B0520	4	Screw-Pan-WP-Cros
510	510A5100	1	Key-Woodruff

Ref. No.	Part No.	Qty.	Description

# Control-Equipment Assembly Kawasaki FH500V-AS25 3325-194

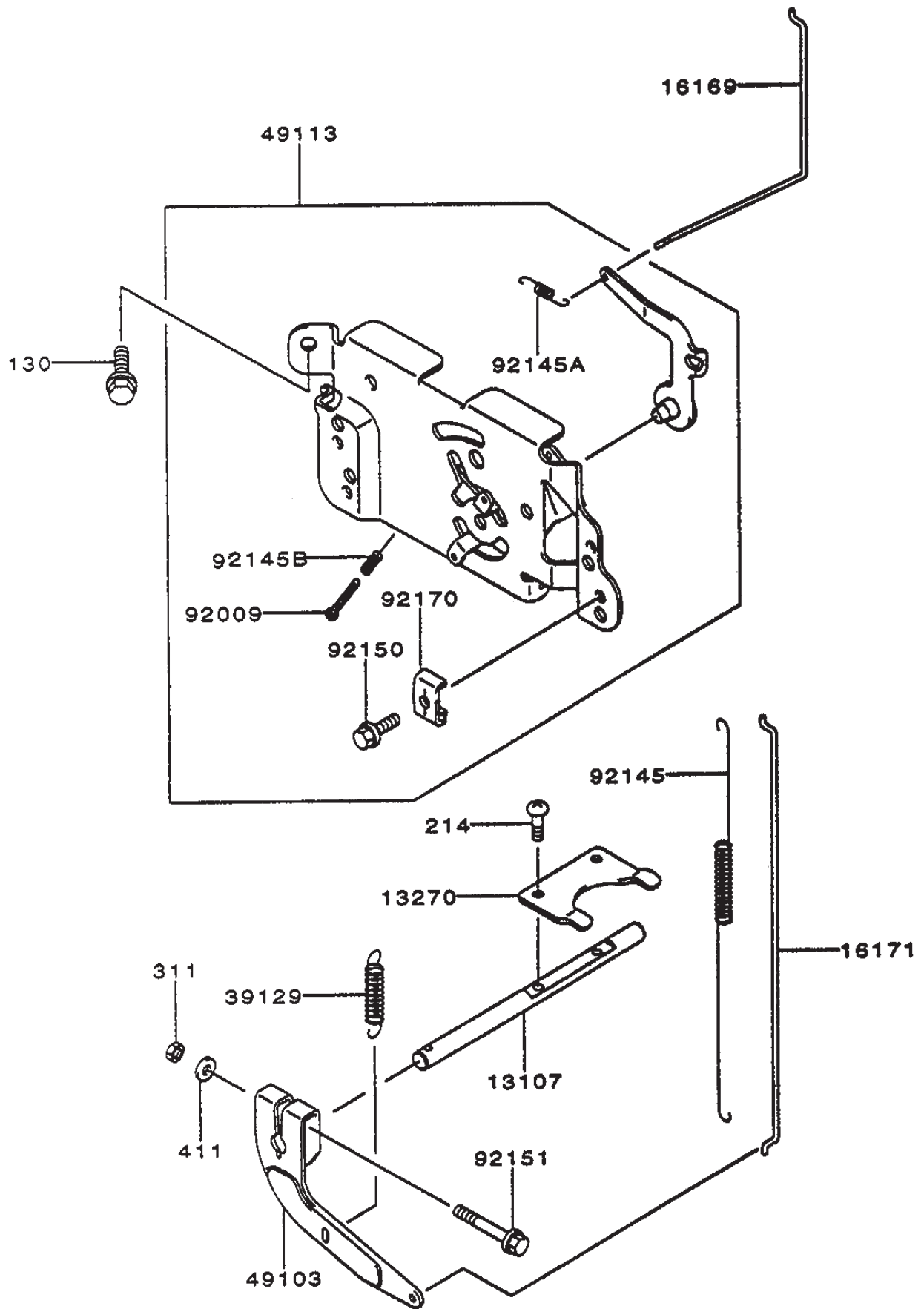

# Control-Equipment Assembly Kawasaki FH500V-AS25

Ref. No.	Part No.	Qty.	Description
13107	13107-7002	1	Shaft
13270	13270-7006	1	Plate
16169	16169-7001	1	Link-Choke
16171	16171-7001	1	Link
39129	39129-7003	1	Spring-Governor
49103	49103-7001	1	Arm-Governor
49113	49113-7001	1	Panel-Comp-Control
92009	92009-7002	1	Screw, 4x30
92145	92145-7003	1	Spring
92145A	92145-7004	1	Spring
92145B	92145-7005	1	Spring
92150	92150-2182	1	Bolt, 5x18
92151	92151-7006	1	Bolt, 6x30
92170	92170-7001	1	Clamp
130	130B0612	2	Bolt-Flanged
214	214B0408	2	Screw-Pan
311	311B0600	1	Nut-Hex
411	411B0600	1	Washer-Plain

Ref. No.	Part No.	Qty.	Description



# Carburetor Assembly Kawasaki FH500V-AS25

Ref. No.	Part No.	Qty.	Description	Ref. No.	Part No.	Qty.	Description
11003	11003-2105	1	Seat-Valve				
11060	11060-2406	1	Gasket				
11060A	11060-7003	2	Gasket, Insulator				
11060B	11060-7004	1	Gasket, Air Filter				
11060C	11060-7005	2	Gasket				
	11065-2061	1	Cap				
15003	15003-2698	1	Carburetor-Assy				
16014	16014-2080	1	Screw-Pilot Air				
16020	16020-2141	1	Chamber-Float				
16021	16021-2060	1	Screw-Throttlestop				
16025	16025-2193	1	Valve-Throttle, #130				
16030	16030-2067	1	Valve-Float				
16031	16031-2066	1	Float				
16035	16035-2060	1	Jet-Air, #1.7				
16035A	16035-2061	1	Jet-Air, #1.2				
16041	16041-2252	1	Shaft-Carburetor, Choke				
16041A	16041-2253	1	Shaft-Carburetor Throttle				
	16073-7001	1	Insulator				
16126	16126-2219	1	Valve				
39076	39076-2053	1	Limiter				
43058	43058-3716	1	Ring				
49121	49121-2222	1	Nozzle-Main				
59076	59076-7001	1	Manifold-Intake				
92009	92009-2015	1	Screw				
92009A	92009-2024	2	Screw				
92009B	92009-2081	1	Screw				
92022	92022-2231	1	Washer				
92022A	92022-2239	1	Washer				
92027	92027-2025	1	Collar				
92033	92033-2067	1	Ring-Snap				
92043	92043-2226	1	Pin				
92063	92063-2358	1	Jet-Main				
92064	92064-2125	1	Jet-Pilot				
92081	92081-2009	2	Spring				
92081A	92081-2256	1	Spring				
92093	92093-2002	1	Seal				
92145	92145-2061	1	Spring				
92151	92151-2092	1	Bolt				
92191	92191-7008	1	Tube				
	130 130B0635	4	Bolt-Flanged				
	172 172G0685	2	Bolt-Stud				
	482 482L4000	1	Circlip-Type-E				







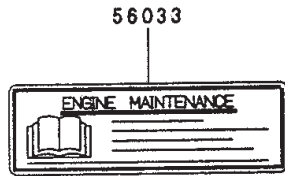
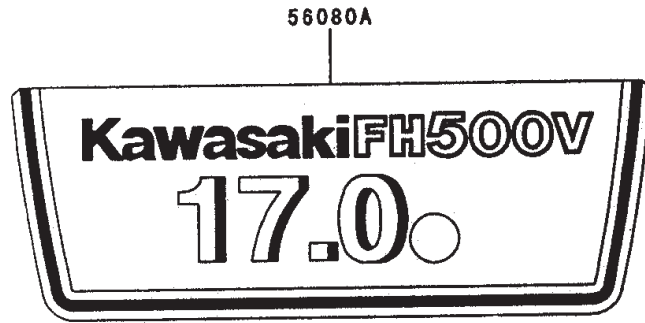

### Starter/Decals Kawasaki FH500V-AS25

Ref. No.	Part No.	Qty.	Description
56033	56033-7001	1	Label-Manual
56080	56080-2077	1	Label-Brand
56080A	56080-7001	1	Label-Brand

Ref. No.	Part No.	Qty.	Description



