



Mid-Size Mower
ProLine Gear with Side Discharge Mower
Model No. 30260—210000001 and Up

Parts Catalog

Ordering Replacement Parts

To order replacement parts, please supply: the part number, the quantity, and the description of each part desired.

Understanding Reference Numbers

Each identified part in an illustration has a reference number. The reference number for a part also appears in the parts list, along with other information about the part.

This catalog uses two special reference number formats, one to indicate parts in a service assembly and another to indicate the quantity of a given part in an illustration.

Service Assembly Reference Numbers

Parts in service assemblies have reference numbers in the form **a:b**. The **a** represents the reference number of the entire service assembly and the **b** represents a sequential number unique to each part within the service assembly.

For example, a wheel assembly might be identified by reference number **6**, the tire by **6:1**, the valve by **6:2**, and the wheel by **6:3**. When you order the assembly identified by reference number **6**, you receive all parts identified by reference numbers **6:1**, **6:2**, and **6:3**. However, you may also order any part individually.

Reference numbers of this type appear in illustrations and in part lists.

Reference Numbers Indicating Quantity

In an illustration, if a reference number indicates more than one part, the reference number has the form **nX y**. The **n** represents the quantity of the part, the **X** is the multiplication symbol, and the **y** represents the reference number.

For example, in an illustration, the reference number **2X 37** means that two of the parts identified by reference number **37** are indicated.

Contents

Description	Page	Description	Page
Engine and Clutch Assembly	3	Cooling-Equipment Assembly	
Clutch Assembly No. 54-3200	4	Kawasaki FH500V-AS25	22
Fuel Tank Assembly	5	Electric-Equipment Assembly	
Lower Controls Assembly	6	Kawasaki FH500V-AS25	24
Transmission and Drive System Assembly	7	Control-Equipment Assembly	
Wheel Drive and Brake System Assembly	8	Kawasaki FH500V-AS25	26
Handle Assembly	9	Carburetor Assembly	
Control Panel Assembly	10	Kawasaki FH500V-AS25	28
Deck Assembly	11	Air-Filter/Muffler Assembly	
Spindles, Idler Pulleys, and Belts Assembly ...	12	Kawasaki FH500V-AS25	30
Carrier Frame Assembly	15	Fuel-Tank/Fuel-Valve Assembly	
Cylinder/Crankcase Assembly		Kawasaki FH500V-AS25	31
Kawasaki FH500V-AS25	16	Starter	
Valve/Camshaft Assembly		Kawasaki FH500V-AS25	32
Kawasaki FH500V-AS25	18	Starter/Decals	
Piston/Crankshaft Assembly		Kawasaki FH500V-AS25	33
Kawasaki FH500V-AS25	20	Electrical Schematic	34
Lubrication-Equipment Assembly			
Kawasaki FH500V-AS25	21		

Part Description Abbreviations

Part descriptions in this catalog may include the following abbreviations.

Abbreviation	Meaning	Abbreviation	Meaning
AR	as required	HYD	hydraulic
ASM	assembly	INC	incorporated
CARR	carriage	LH	left hand
DEG	degrees	NI	nylon insert
FH	flat head	PPH	Phillips pan head
GA	gauge	PTH	Phillips truss head
HF	hex flange	PTO	power take off
HH	hex head	RH	right hand
HHF	hex head flange	SFH	slotted fillister head
HLH	hex lag head	SHH	slotted hex head
HJ	hex jam	SQH	square head
HOC	height-of-cut	SHWH	slotted hex washer head
HS	hex socket	SPH	slotted pan head
HSBH	hex socket button head	SRH	slotted round head
HSFH	hex socket flat head	STD	standard
HSH	hex socket head	TAP	self tapping
HWH	hex washer head	TTH	Torx truss head
HWHTF	hex washer head thread forming	WH	wing head

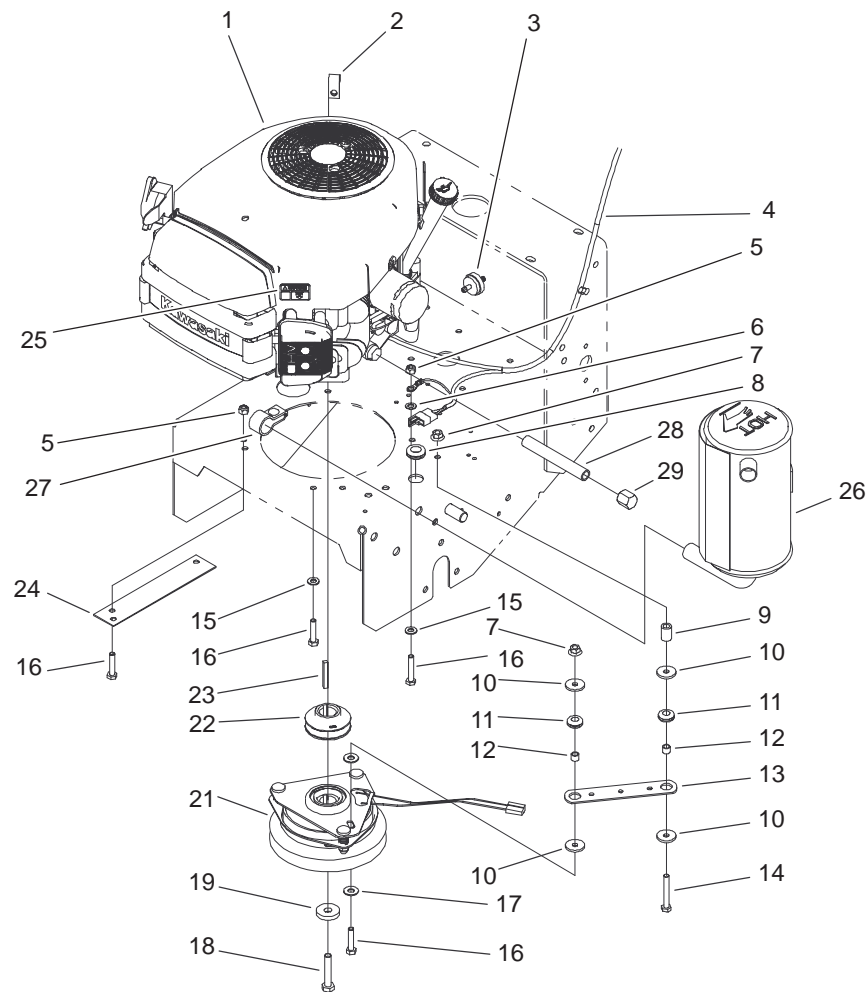

Sheet No.: 4

Engine and Clutch Assembly

Ref. No.	Part No.	Qty.	Description	Ref. No.	Part No.	Qty.	Description
1		1	Engine-Kawasaki, Fh500v-As25	27	100-6468	1	Clamp-Muffler
2	2412-87	1	Clamp-Cable	28	289-19	1	Nipple
3	56-6360	1	Filter-Fuel	29	288-10	1	Cap-Pipe
4	104-8137	1	Wire Harness				
5	3296-29	4	Nut-Lock				
6	3255-8	1	Washer-Lock/Ext				
7	32128-20	2	Nut-HF				
8	237-124	1	Grommet				
9	104-6373	1	Tube - Retainer				
10	1-613235	4	Washer				
11	1-633630	2	Grommet-Brake				
12	1-633545	2	Spacer-Grommet				
13	1-633543	1	Strap,Clutch/Brake				
14	322-11	1	Screw-HH				
15	3256-23	2	Washer-Flat				
16	322-7	5	Screw-HH				
17	3256-3	2	Washer-Flat				
18	3212-9	1	Screw-HH				
19	112843	1	Washer				
21	54-3200	1	Clutch/Brake				
22	105-0827	1	Pulley-Drive				
23	608006	1	Key				
24	94-5847-01	1	Cover - Pulley				
25	63-8440	1	Decal-Hot Surface				
26	100-6467	1	Muffler				

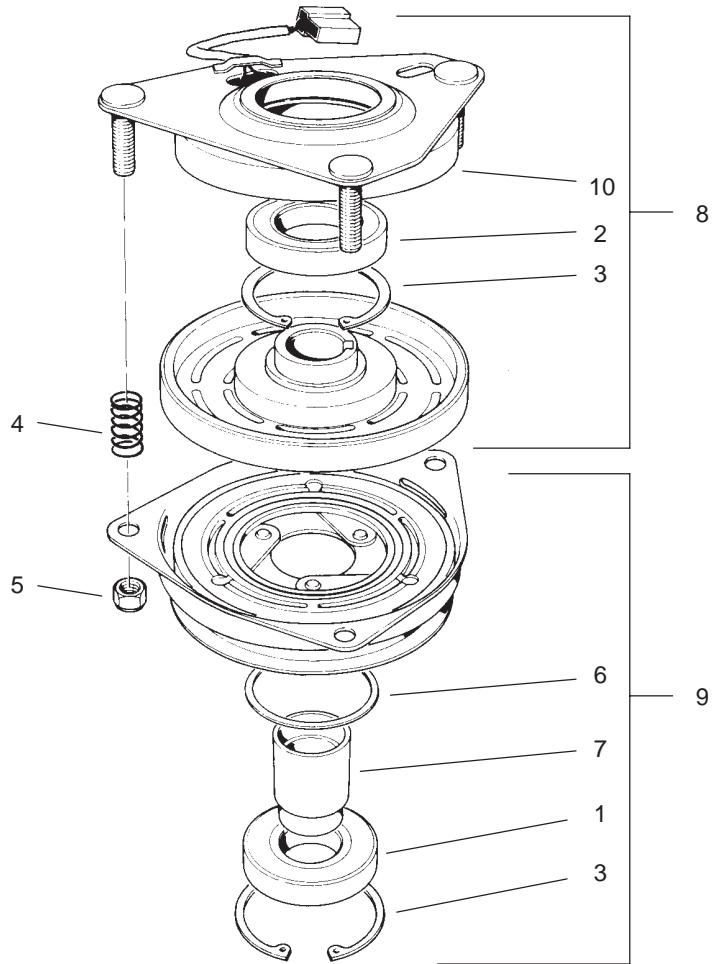

Sheet No.: A1
T-3726

Clutch Assembly No. 54-3200

Ref. No.	Part No.	Qty.	Description
1	251-291	1	Bearing-Pulley
2	251-292	1	Bearing-Field
3	44-8310	2	Ring-Retaining
4	44-8320	3	Spring
5	3296-6	3	Nut-Lock, NI
6	44-8330	1	Spacer-Pulley Bearing
7	44-8340	1	Collar-Bearing
8	44-8360	1	Field Coil-Rotor / Bearing ASM
9	44-8370	1	Armature / Pulley / Bearing ASM
10	54-0230	1	Field Bearing ASM

Ref. No.	Part No.	Qty.	Description

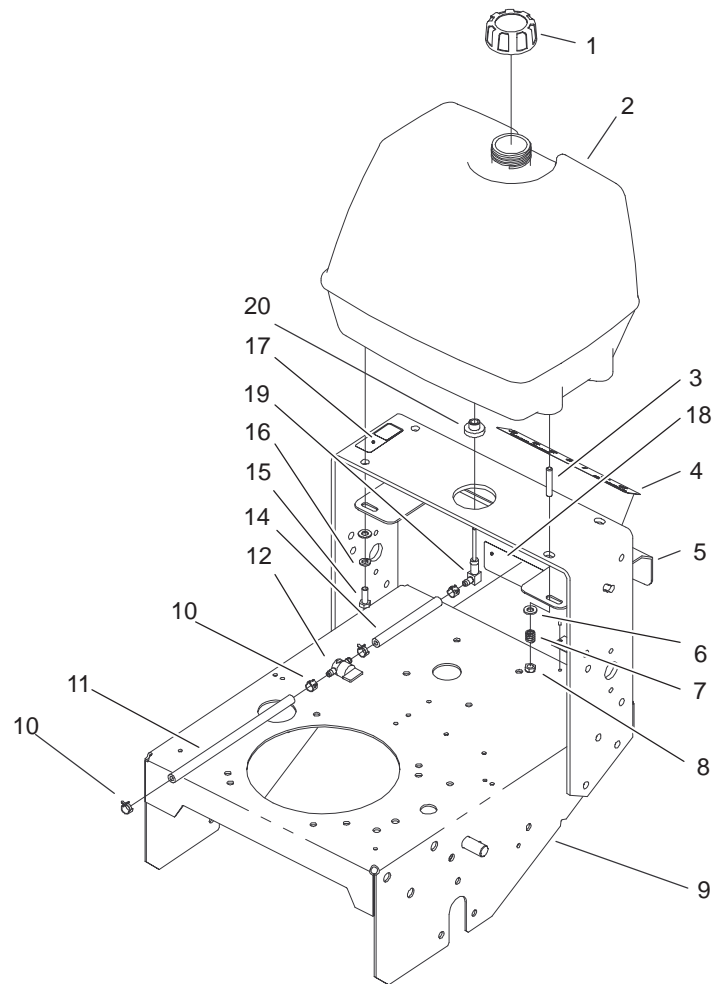

Sheet No.: 5

Fuel Tank Assembly

Ref. No.	Part No.	Qty.	Description
1	55-3570	1	Gas Cap ASM
2	1-323551	1	Tank-Fuel
3	104-8121	2	Stud-Threaded
4	98-3256	1	Decal-Ground Speed
5	104-8102-01	1	Plate-Shift Gate
6	3256-23	4	Washer-Flat
7	1-633349	2	Spring-Tank, Fuel
8	3296-47	2	Nut-Lock, NI
9	104-8100-01	1	Traction Frame ASM
10	2412-98	4	Clamp
11	47-2982	1	Hose-Gas
12	1-603770	1	Valve-Fuel
14	47-2980	1	Hose-Gas
15	322-4	2	Screw-HH
16	3253-4	2	Washer-Lock
17	95-2814	1	Decal-Fuel Shut Off
18	98-0776	1	Decal-Caution
19	1-543277	1	Elbow-Tank, Fuel
20	1-513645	1	Bushing-Valve, Fuel

Ref. No.	Part No.	Qty.	Description

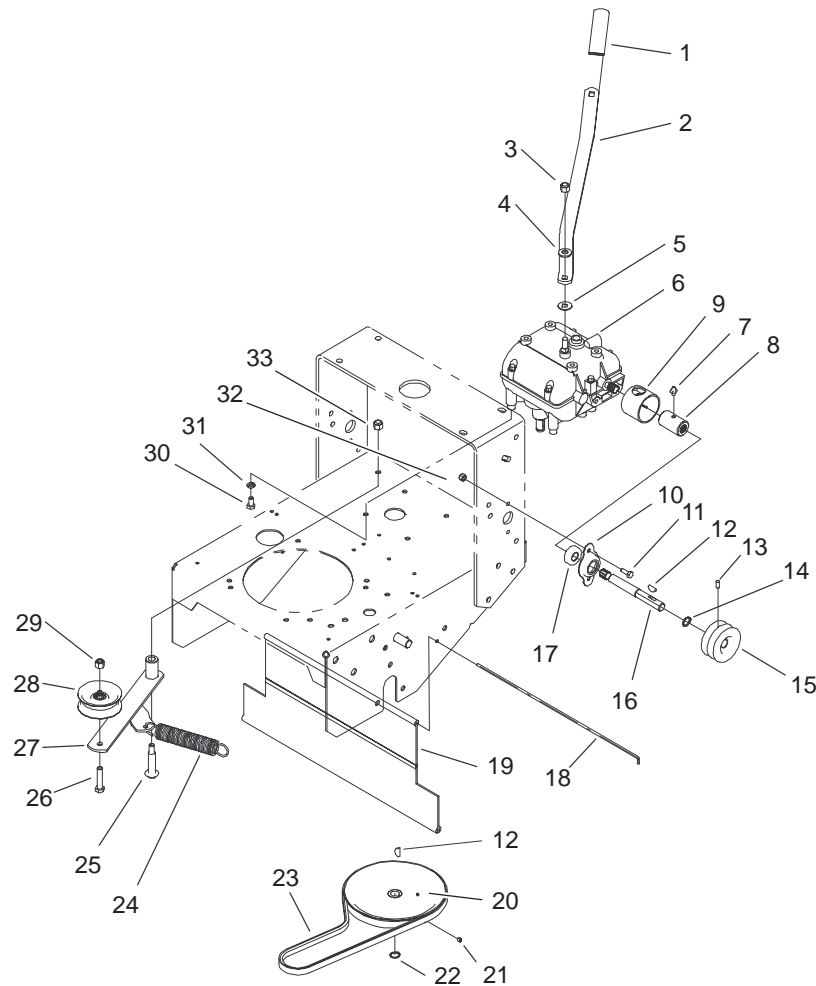

Sheet No.: 7

Transmission and Drive System Assembly

Ref. No.	Part No.	Qty.	Description	Ref. No.	Part No.	Qty.	Description
1	47-1970	1	Grip-Engagement	26	323-9	1	Screw-HH
2	98-3274-03	1	Lever-Shift	27	16-7509	1	Lever-Idler
3	3296-6	1	Nut-Lock, NI	28	62-4540	1	Pulley
4	98-5975	1	Washer-Belleville	29	3296-39	1	Nut-Lock, NI
5	1-323379	1	Washer-Shifter Lever	30	322-2	4	Screw-HH
6	1-323500	1	Transmission, Peerless	31	3253-4	4	Washer-Lock
7	302-5	2	Fitting-Grease	32	3296-42	4	Nut-Lock, NI
8	98-0789	2	Coupler	33	3296-6	1	Nut-Lock, NI
9	51-4220	2	Guard-Coupler				
10	1-323254	2	Flange-Output				
11	321-4	4	Screw-HH				
12	3257-5	3	Key-Woodruff				
13	3245-9	2	Screw-Set				
14	32151-62	2	Ring-Retaining				
15	105-0828	2	Pulley-Transmission				
16	104-1102	2	Shaft-Output				
17	1-323252	2	Bearing-Shaft, Transmission				
18	95-1529	1	Rod-Shield				
19	95-1526	1	Shield-Trailing				
20	51-4190	1	Pulley-Driven				
21	3245-1	1	Screw-Set, HSH				
22	32120-64	1	Ring-Snap, External				
23	26-9671	1	V-Belt				
24	68-2190	1	Spring-Extension				
25	27-6230	1	Bolt-Wheel				

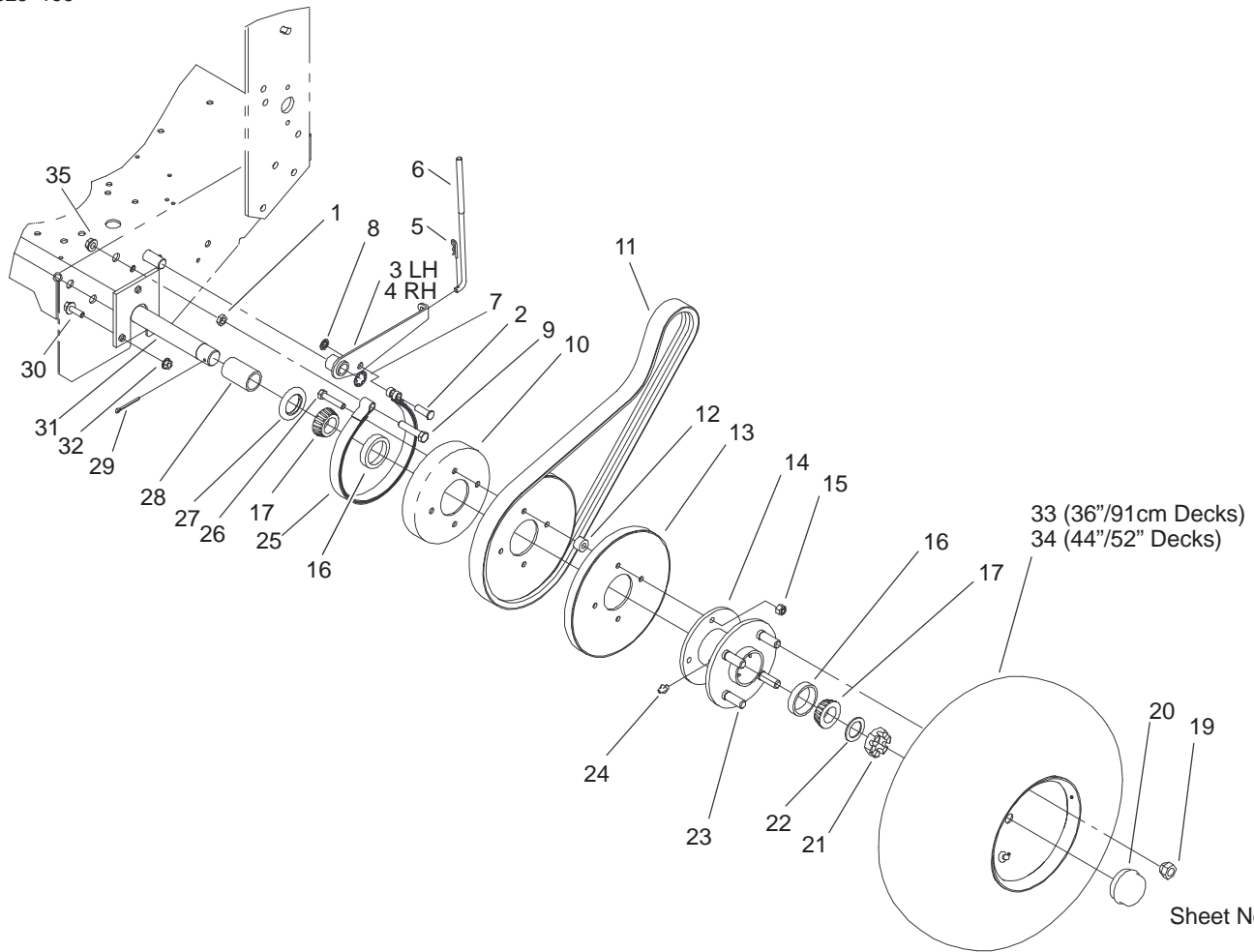

Sheet No.: 8

Wheel Drive and Brake System Assembly

Ref. No.	Part No.	Qty.	Description
1	3218-3	2	Nut-Jam
2	1-323307	2	Pin - Clevis
3	51-4610-01	1	Arm-LH Brake
4	51-4600-01	1	Arm-RH Brake
5	3290-307	2	Pin-Hair
6	51-4580	2	Rod-Brake
7	32151-40	2	Ring-Retaining
8	32151-56	2	Ring-Retaining, Ext
9	323-9	2	Screw-HH
10	1-323261	2	Drum, Brake
11	104-8152	2	Belt-Traction Drive
12	51-4170	8	Spacer-Pulley
13	51-4160-03	4	Pulley-Wheel
14	1-413333	2	Hub, Wheel W/Cups
15	3296-29	8	Nut-Lock
16	254-72	4	Bearing-Taper/Cup
17	254-94	4	Bearing-Taper/Cone
19	242-50	8	Nut-Lug
20	241-119	2	Cap-Dust
21	1-809082	2	Nut, SHH
22	1-523157	2	Washer-Spacer
23	1-633926	8	Stud-Wheel
24	302-19	2	Fitting-Grease
25	1-323262	2	Band, Brake
26	322-8	8	Screw-HH
27	1-543511	2	Seal-Grease

Ref. No.	Part No.	Qty.	Description
28	104-1197	2	Spacer-Wheel
29	1-806800	2	Pin-Cotter
30	3234-11	6	Screw-HHF
31	104-1196-01	1	Axle ASM
32	32128-21	6	Nut-HF
34	104-1198	2	Wheel And Tire ASM
35	3290-357	2	Nut-Flange, Lock

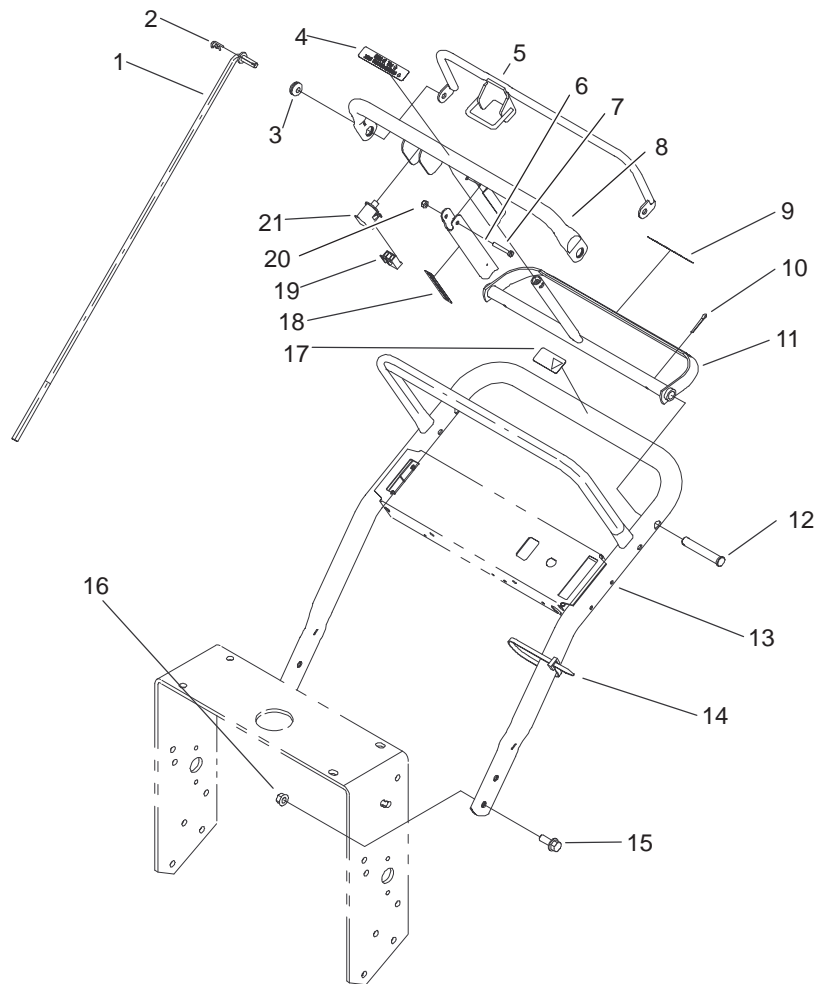

Sheet No.: 9

Handle Assembly

Ref. No.	Part No.	Qty.	Description	Ref. No.	Part No.	Qty.	Description
1	82-7631	2	Rod-Control				
2	3290-307	2	Pin-Hair				
3	237-141	2	Grommet-Rubber				
4	82-2290	1	Decal-Control Bar				
5	82-7680-03	1	Bail				
6	51-4850-03	1	Lever-Parking Brake				
7	32105-1	1	Screw-SHH				
8	82-7690-03	1	Bar-Control				
9	82-2280	1	Decal-Reverse Handle				
10	3272-11	2	Pin-Cotter				
11	99-8501-03	1	Control-Pivot				
12	283-55	2	Pin-Clevis				
13	67-6440-03	1	Handle-Upper				
14	3290-378	1	Tie-Cable				
15	3234-11	4	Screw-HHF				
16	32128-21	4	Nut-HF				
17	98-4387	1	Decal-Protection, Ear				
18	52-2010	1	Decal-Parking Lever				
19	218-595	1	Connector-Body				
20	32153-1	1	Nut-Lock				
21	82-2190	1	Switch-Bail				

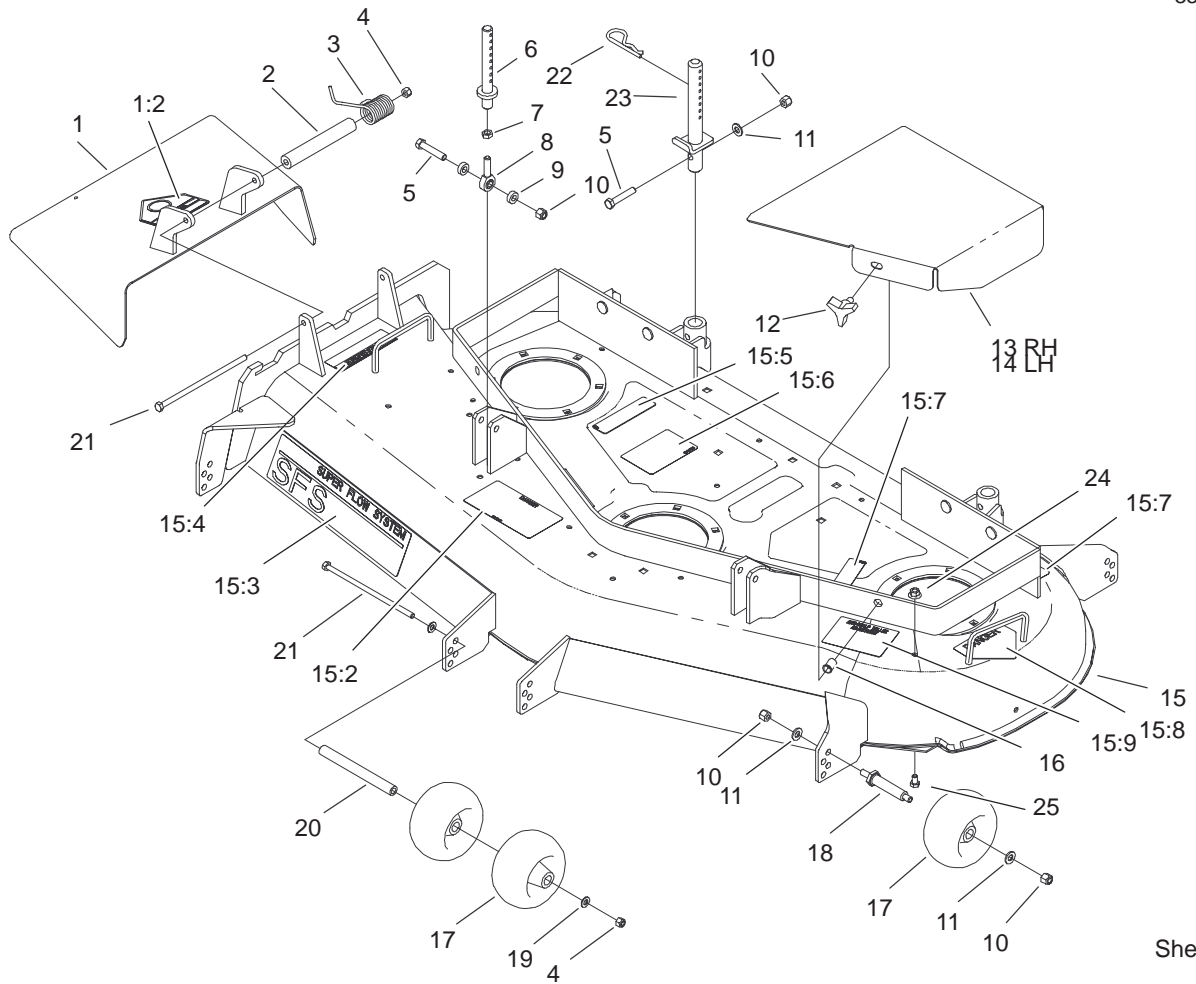

Sheet No.: 2

Deck Assembly

Ref. No.	Part No.	Qty.	Description
1	104-7753	1	Deflector ASM
1:2	54-9220	1	Decal-Danger
2	104-8555	1	Spacer-Mounting, Deflector
3	104-8554	1	Spring-Torsion
4	3296-29	2	Nut-Lock
5	323-10	4	Screw-HH
6	105-0832	2	Link-Support
7	3220-3	2	Nut-Jam
8	1-613204	2	Balljoint
9	104-1156	4	Spacer
10	3296-39	12	Nut-Lock, NI
11	3256-24	10	Washer-Flat
12	104-8587	2	Knob
13	104-6389-01	1	Cover-Belt, Right
14	104-6388-01	1	Cover-Belt, Left
15	104-6394	1	Deck ASM
15:2	66-1340	1	Decal-Danger
15:3	98-5953	1	Decal-Sfs
15:4	104-8569	1	Decal-Deflector Warning
15:5	67-5360	3	Decal-Danger
15:6	104-8186	1	Decal-Belt Routing
15:7	68-8340	1	Decal-Torque
15:8	43-8480	1	Decal-Danger
15:9	105-0840	1	Decal-Anti Scalp

Ref. No.	Part No.	Qty.	Description
16	32148-10	2	Insert-Threaded
17	68-2730	6	Gage-Wheel
18	99-2842	4	Spacer-Wheel
19	3256-23	2	Washer-Flat
20	98-5967	1	Spacer - Wheel
21	322-50	2	Screw-Cap
22	3290-256	6	Pin-Hair
23	105-0831	2	Rod ASM
24	32128-20	7	Nut-HF
25	322-1	7	Screw-HH

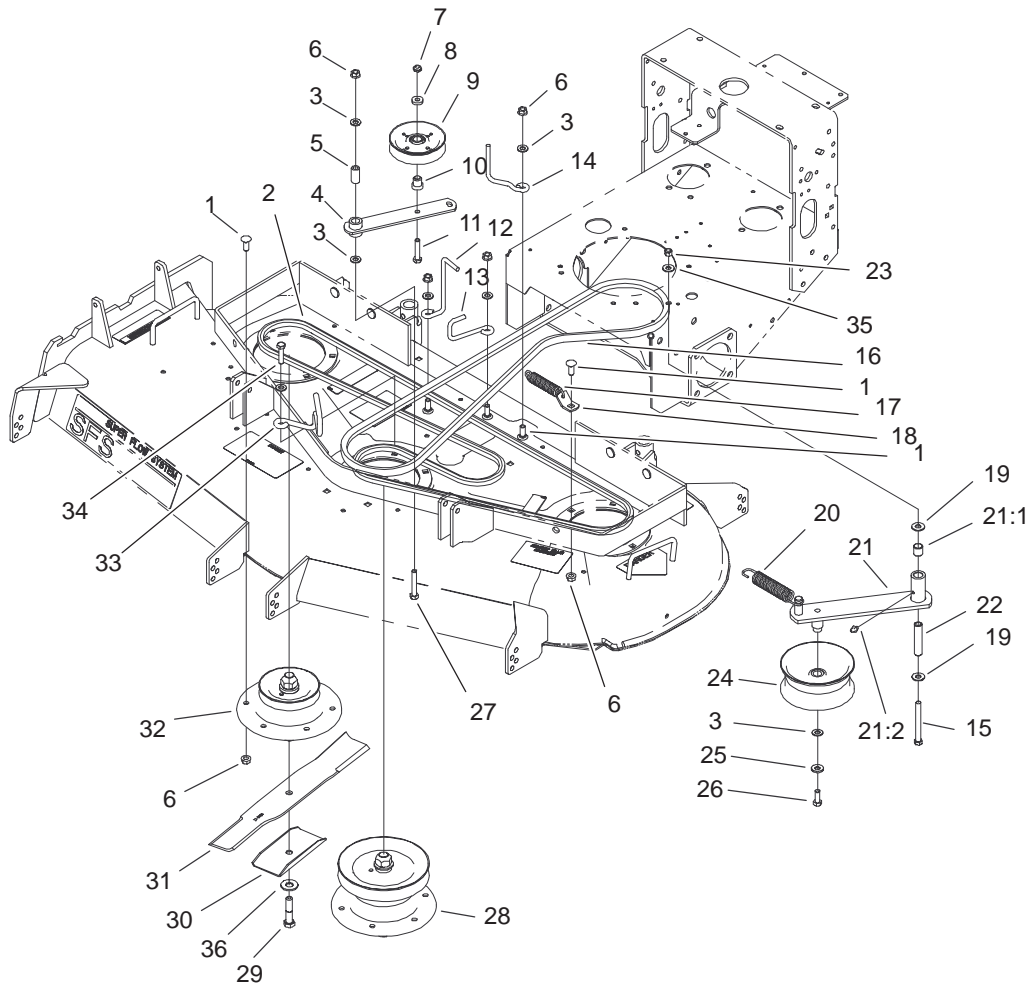

Sheet No.: 3

Spindles, Idler Pulleys, and Belts Assembly

Ref. No.	Part No.	Qty.	Description
1	3231-22	19	Screw-CARR
2	104-6397	1	V-Belt, Deck
3	3256-24	7	Washer-Flat
4	104-6375	1	Idler Arm ASM
5	51-3640	1	Sleeve-Pivot, Idler
6	32128-21	21	Nut-HF
7	3296-5	1	Nut-Lock NI
8	7-0081	1	Washer-Flat
9	65-5940	1	Pulley-Idler
10	104-6379	1	Bushing-Pulley
11	3211-8	1	Screw-HH
12	98-5980	1	Guide - Belt
13	104-6396	1	Guide-Belt
14	52-4780	1	Rod-Belt
15	323-42	1	Screw-HH
16	104-6398	1	V-Belt, PTO
17	51-3650	1	Spring - Extension
18	104-6374	1	Plate - Spring
19	1-809107	2	Washer-Hardened
20	104-8161	1	Spring-Extension
21	104-6370	1	Idler Arm ASM
21:1	1-513034	2	Sleeve-Bearing
21:2	302-5	1	Fitting-Grease
22	104-6377	1	Tube - Idler
23	3296-39	1	Nut-Lock, NI
24	1-413099	1	Pulley-Idler

Ref. No.	Part No.	Qty.	Description
25	98-5975	1	Washer-Belleville
26	323-6	1	Screw-HH
27	323-11	1	Screw-HH
28	104-6315	1	Spindle Housing ASM
29	44-2200	3	Screw - Blade
30	92-9820	3	Stiffener - Blade
31	27-0990	3	Blade
32	104-6317	2	Spindle Housing ASM
33	105-0850	1	Guide-Belt
34	323-8	1	Screw-HH
35	3256-4	1	Washer-Flat
36	3256-6	3	Washer-Flat

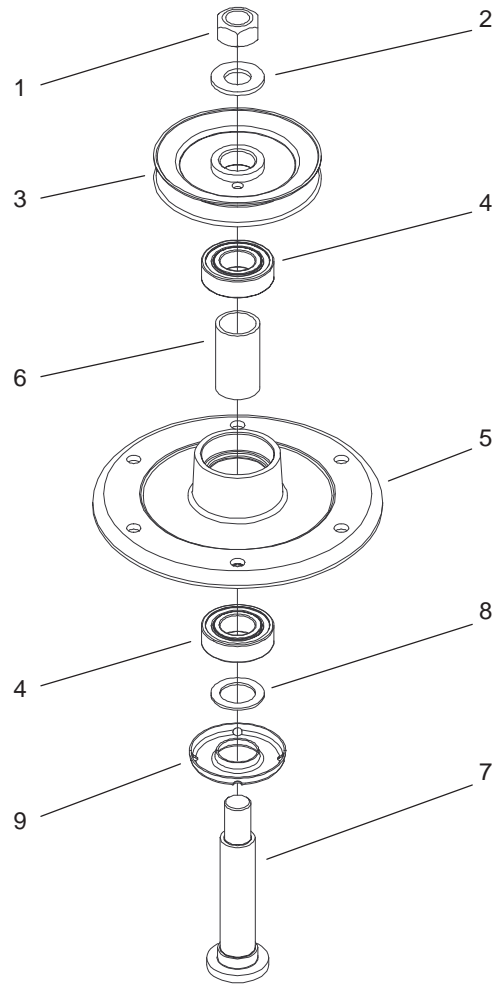

Sheet No.: A2
C-3012

Spindle Housing Assembly No. 104-6317

Ref. No.	Part No.	Qty.	Description
1	3219-7	1	Nut-Hex
2	7-4150	1	Washer-Pinion
3	104-1118	1	Pulley And Hub ASM
4	104-6325	2	Bearing
5	104-6307	1	Spindle Housing
6	104-6313	1	Spacer-Bearing
7	104-6310	1	Shaft-Spindle
8	88-7540	1	Washer - Backup
9	79-1920	1	Shield-Bearing

Ref. No.	Part No.	Qty.	Description

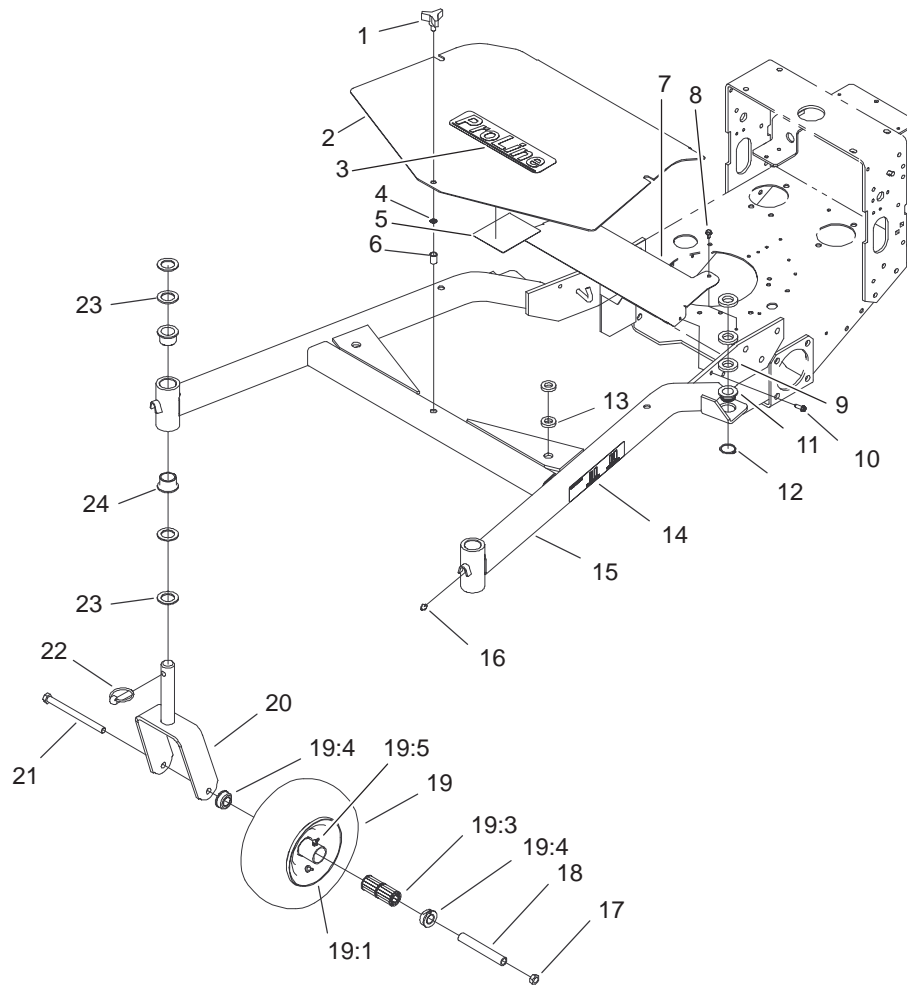

Sheet No.: 4

Carrier Frame Assembly

Ref. No.	Part No.	Qty.	Description
1	104-8587	3	Knob
2	104-8153-01	1	Cover-Carrier Frame
3	74-2080	1	Decal-Proline
4	32151-72	1	Ring-Retaining
5	104-8175	1	Decal-Service, Gear
5	104-8173	1	Decal-Service, Hydro
6	32148-9	3	Nut-Insert
7	105-0845-01	1	Shield-Heat
8	12-3270	2	Screw
9	104-1105	6	Spacer-Deck Support
10	49-2040	2	Screw-Tapping
11	1-513336	2	Bushing - Deck
12	32120-33	2	Ring-Retaining
13	105-0842	4	Spacer
14	104-8171	2	Decal-HOC
15	104-1109-01	1	Carrier Frame ASM
16	302-5	2	Fitting-Grease
17	32153-5	2	Nut-Lock
18	104-1189	2	Bushing-Spanner
19	104-1170	2	Castor Wheel ASM
19:1	104-1169	1	Tire And Tube ASM
19:3	62-5570	2	Bearing-Roller
19:4	62-5580	2	Bearing-Outside
19:5	302-11	1	Fitting-Lube, 45°
20	104-1183-01	2	Castor Fork ASM
21	325-33	2	Screw-HH

Ref. No.	Part No.	Qty.	Description
22	283-71	2	Pin-Lynch
23	3-6781	8	Washer-Thrust
24	94-1291	4	Bushing-Special

Cylinder/Crankcase Assembly Kawasaki FH500V-AS25

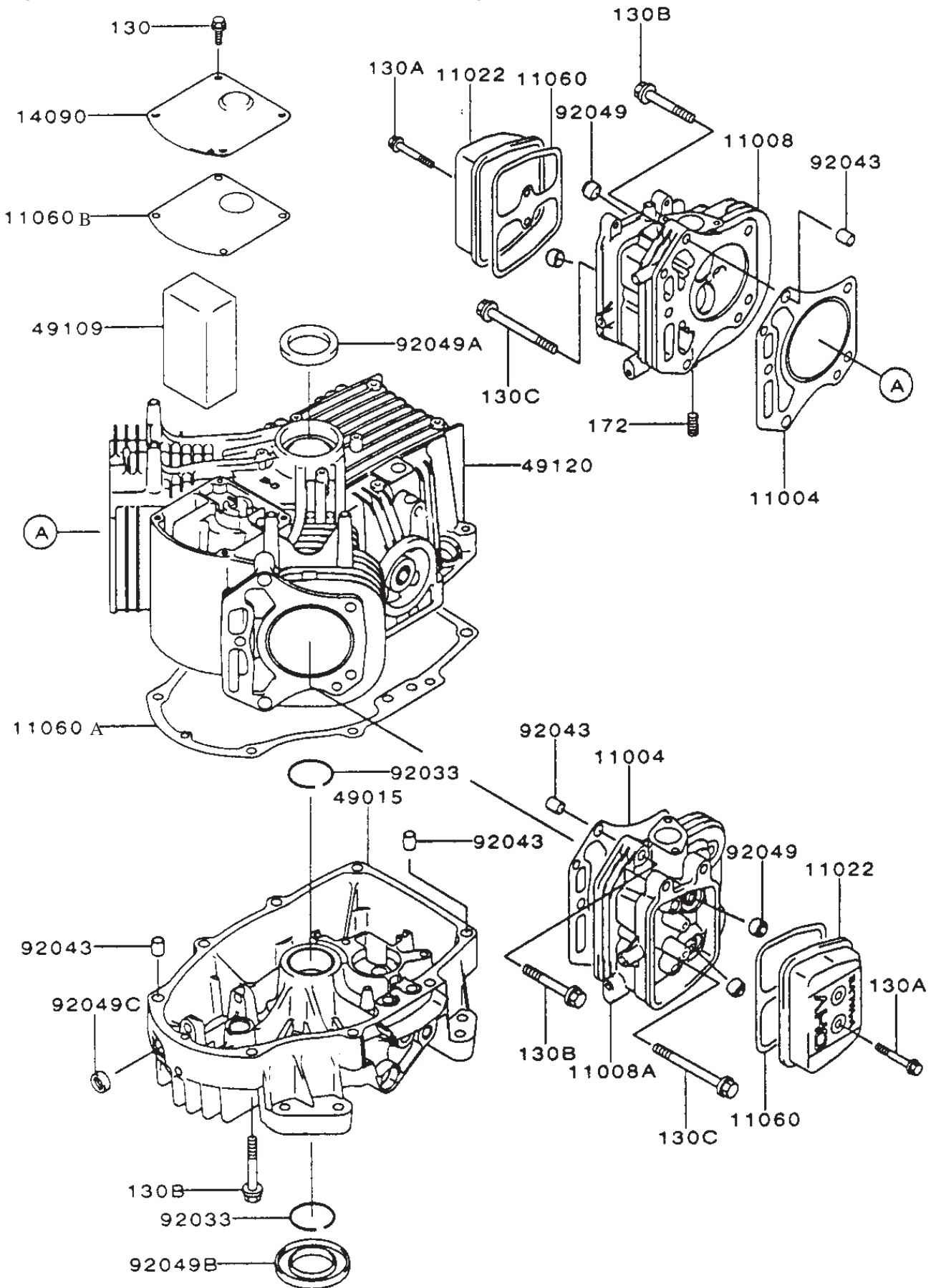

Cylinder/Crankcase Assembly Kawasaki FH500V-AS25

Ref. No.	Part No.	Qty.	Description
11004	11004-7001	2	Gasket-Head
11008	11008-7001	1	Head-Comp-Cylinder No. 1
11008A	11008-7002	1	Head-Comp-Cylinder No. 2
11022	11022-7001	2	Case-Rocker
11060	11060-7001	2	Gasket, Rocker Case
11060A	11060-7008	1	Gasket, Crankcase Cover
11060B	11060-7015	1	Gasket, Breather
14090	14090-7001	1	Cover, Breather
49015	49015-6215	1	Cover-Crankcase
49109	49109-7002	1	Element-Breather
49120	49120-6119	1	Crankcase-Comp
92033	92033-7003	2	Ring-Snap
92043	92043-7001	6	Pin
92049	92049-7001	4	Seal-Oil
92049A	92049-7002	1	Seal-Oil
92049B	92049-7004	1	Seal-Oil
92049C	92049-7005	1	Seal-Oil
130	130B0612	4	Bolt-Flanged
130A	130B0640	4	Bolt-Flanged
130B	130T0850	17	Bolt-Flanged
130C	130T0875	2	Bolt-Flanged
172	172G0818	4	Bolt-Stud

Ref. No.	Part No.	Qty.	Description

Valve/Camshaft Assembly Kawasaki FH500V-AS25

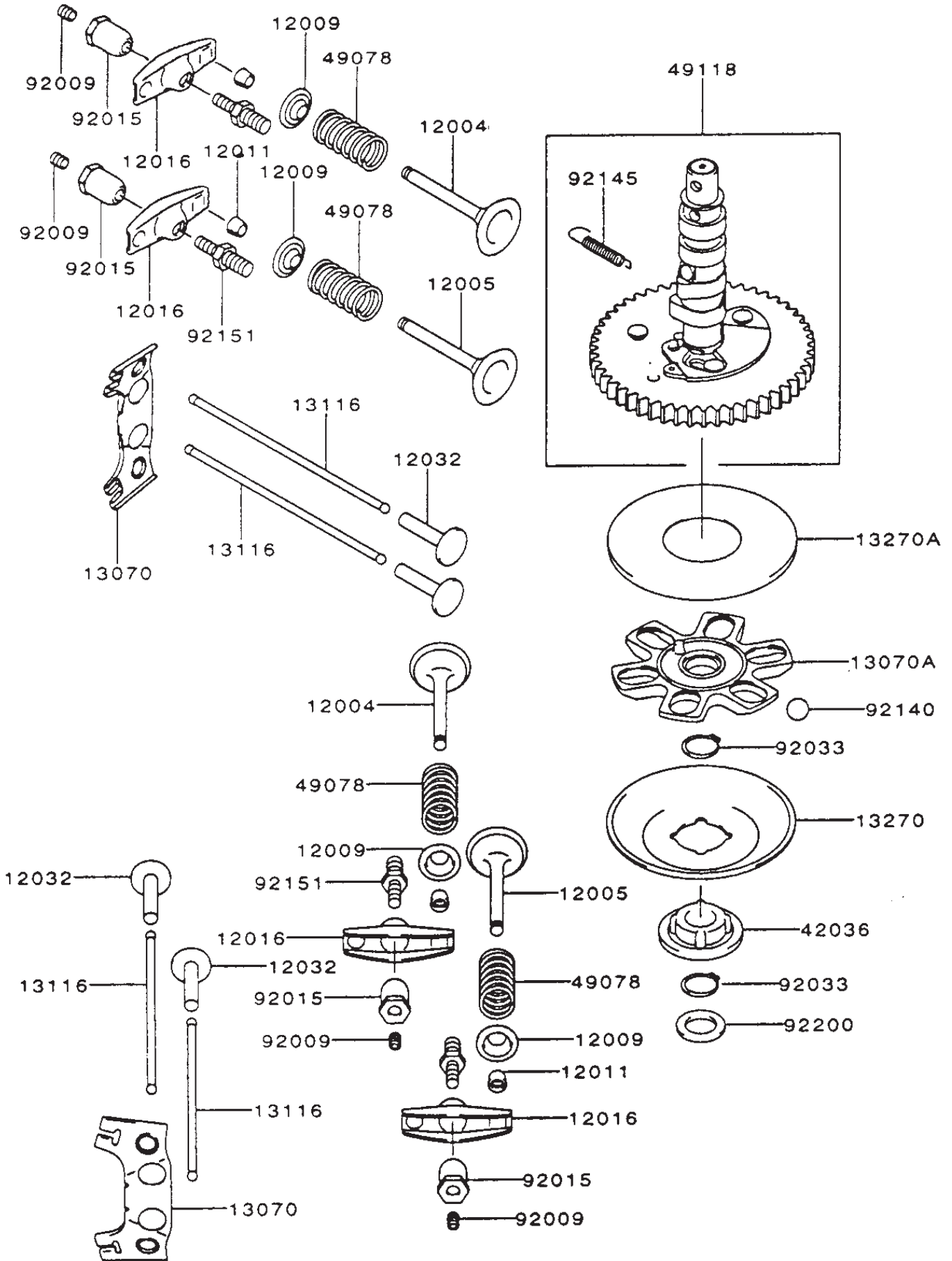

Valve/Camshaft Assembly Kawasaki FH500V-AS25

Ref. No.	Part No.	Qty.	Description
12004	12004-7001	2	Valve-Intake
12005	12005-7001	2	Valve-Exhaust
12009	12009-7001	4	Retainer-Valve Spring
12011	12011-2056	8	Collet
12016	12016-7001	4	Arm-Rocker
12032	12032-7001	4	Tappet
13070	13070-7001	2	Guide
13070A	13070-7002	1	Guide
13116	13116-2057	4	Rod-Push
13270	13270-7002	1	Plate
13270A	13270-7003	1	Plate
42036	42036-7001	1	Sleeve
49078	49078-7001	4	Spring-Engine Valve
49118	49118-7002	1	Camshaft-Comp
92009	92009-2341	4	Screw
92015	92015-2253	4	Nut
92033	92033-7001	2	Ring-Snap
92140	92140-7002	6	Ball
92145	92145-7001	1	Spring
92151	92151-7001	4	Bolt
92200	92200-7001	1	Washer

Ref. No.	Part No.	Qty.	Description

Cooling-Equipment Assembly Kawasaki FH500V-AS25

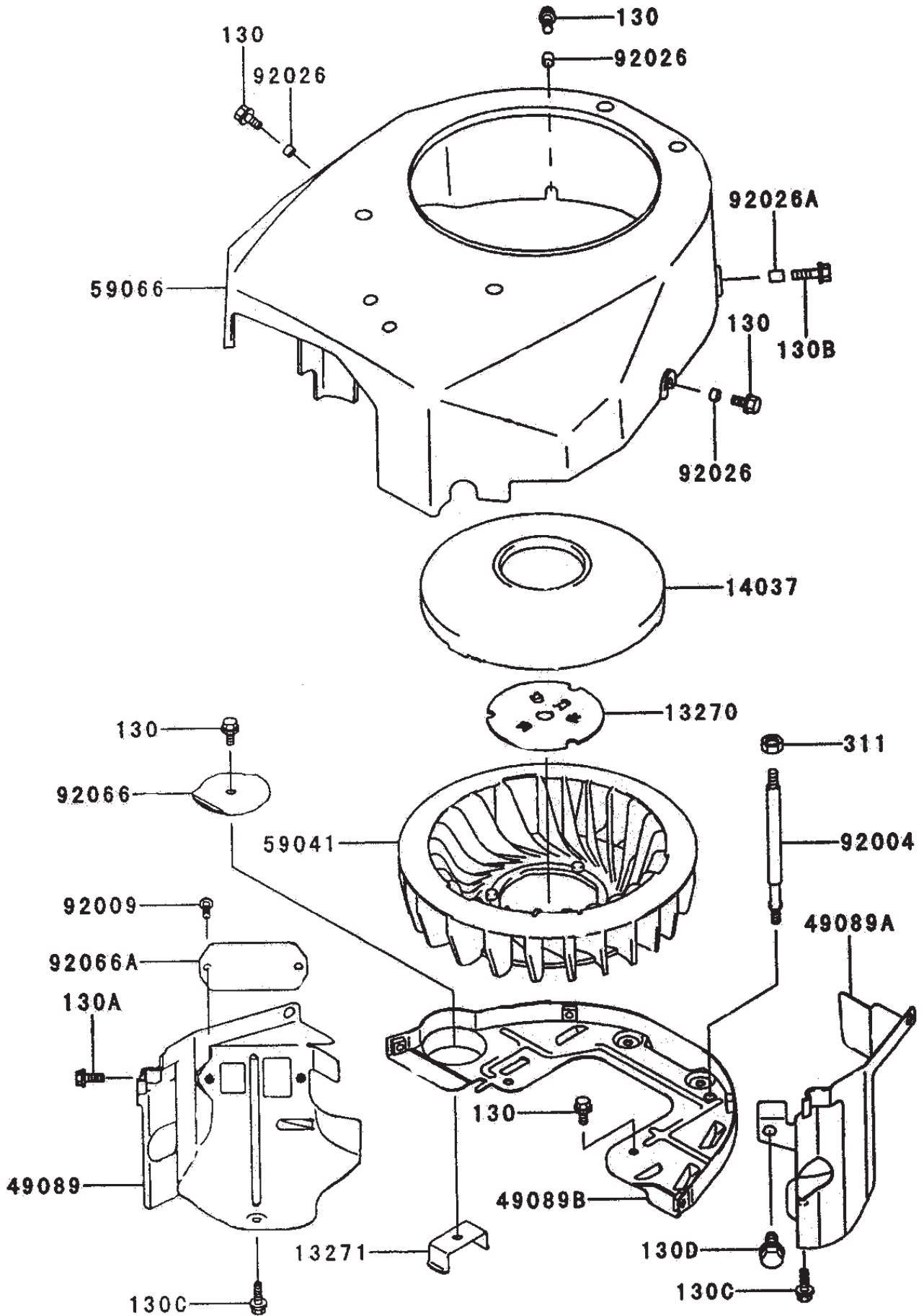

Cooling-Equipment Assembly Kawasaki FH500V-AS25

Ref. No.	Part No.	Qty.	Description
130	130B0612	6	Bolt-Flanged
130A	130B0616	2	Bolt-Flanged
130B	130B0620	1	Bolt-Flanged
130C	130B0625	2	Bolt-Flanged
130D	130B0816	1	Bolt-Flanged
13270	13270-7007	1	Plate
13271	13271-7002	1	Plate
14037	14037-7002	1	Screen
311	311B0600	2	Nut-Hex
49089	49089-7001	1	Shroud-Engine
49089A	49089-7002	1	Shroud-Engine
49089B	49089-7003	1	Shroud-Engine
59041	59041-7001	1	Fan
59066	59066-7002	1	Housing-Fan
92004	92004-7006	2	Stud
92009	92009-2308	2	Screw
92026	92026-7001	3	Spacer, 6.2x7.9x5
92026A	92026-7003	1	Spacer, 6.5x7.9x10.5
92066	92066-7004	1	Plug
92066A	92066-7004	1	Plug

Ref. No.	Part No.	Qty.	Description

Electric-Equipment Assembly Kawasaki FH500V-AS25

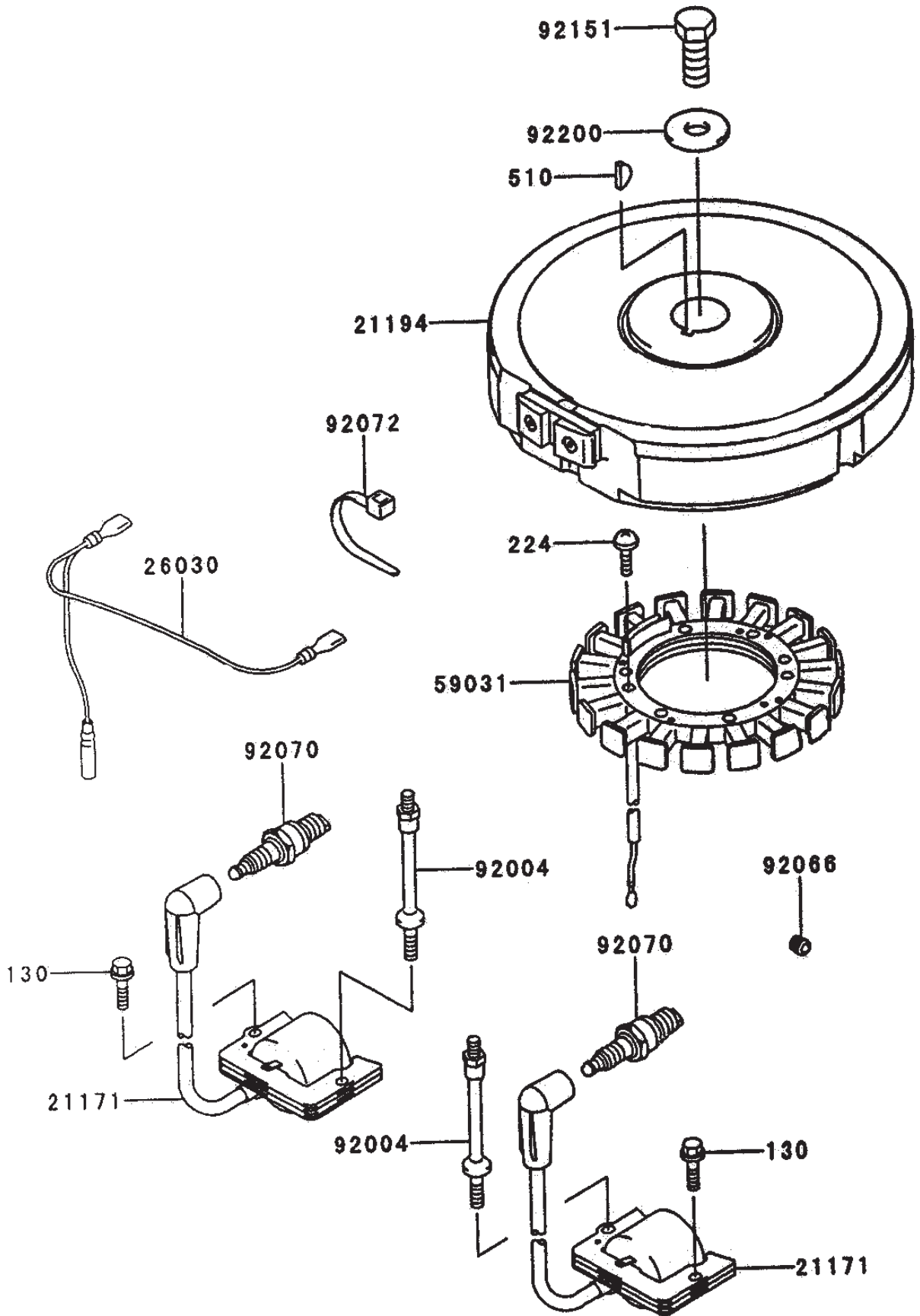

Electric-Equipment Assembly Kawasaki FH500V-AS25

Ref. No.	Part No.	Qty.	Description
21171	21171-7001	2	Coil-Assy-Ignition
21194	21193-7001	1	Flywheel-Assy
26030	26030-7001	1	Harness
59031	59031-7002	1	Coil-Charging
92004	92004-2147	2	Stud
92066	92066-7002	1	Plug
92070	92070-7001	2	Plug-Spark (RCJ8Y)
92072	92072-7001	2	Band
92151	92151-2097	1	Bolt, 12x30
92220	92220-7002	1	Washer
130	130B0620	2	Bolt-Flanged
224	224B0520	4	Screw-Pan-WP-Cros
510	510A5100	1	Key-Woodruff

Ref. No.	Part No.	Qty.	Description

Control-Equipment Assembly Kawasaki FH500V-AS25

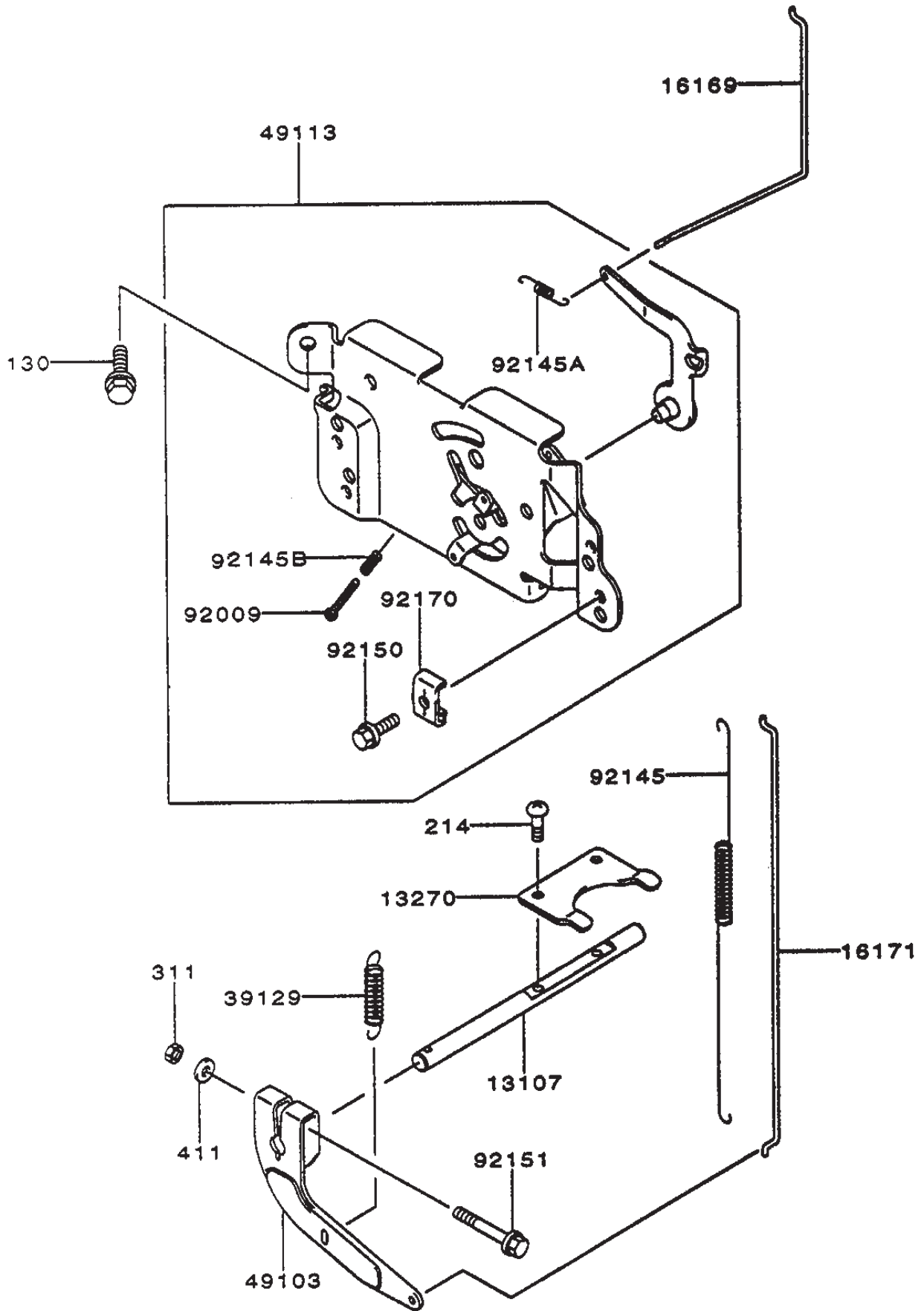

Control-Equipment Assembly Kawasaki FH500V-AS25

Ref. No.	Part No.	Qty.	Description
13107	13107-7002	1	Shaft
13270	13270-7006	1	Plate
16169	16169-7001	1	Link-Choke
16171	16171-7001	1	Link
39129	39129-7003	1	Spring-Governor
49103	49103-7001	1	Arm-Governor
49113	49113-7001	1	Panel-Comp-Control
92009	92009-7002	1	Screw, 4x30
92145	92145-7003	1	Spring
92145A	92145-7004	1	Spring
92145B	92145-7005	1	Spring
92150	92150-2182	1	Bolt, 5x18
92151	92151-7006	1	Bolt, 6x30
92170	92170-7001	1	Clamp
130	130B0612	2	Bolt-Flanged
214	214B0408	2	Screw-Pan
311	311B0600	1	Nut-Hex
411	411B0600	1	Washer-Plain

Ref. No.	Part No.	Qty.	Description

Carburetor Assembly Kawasaki FH500V-AS25

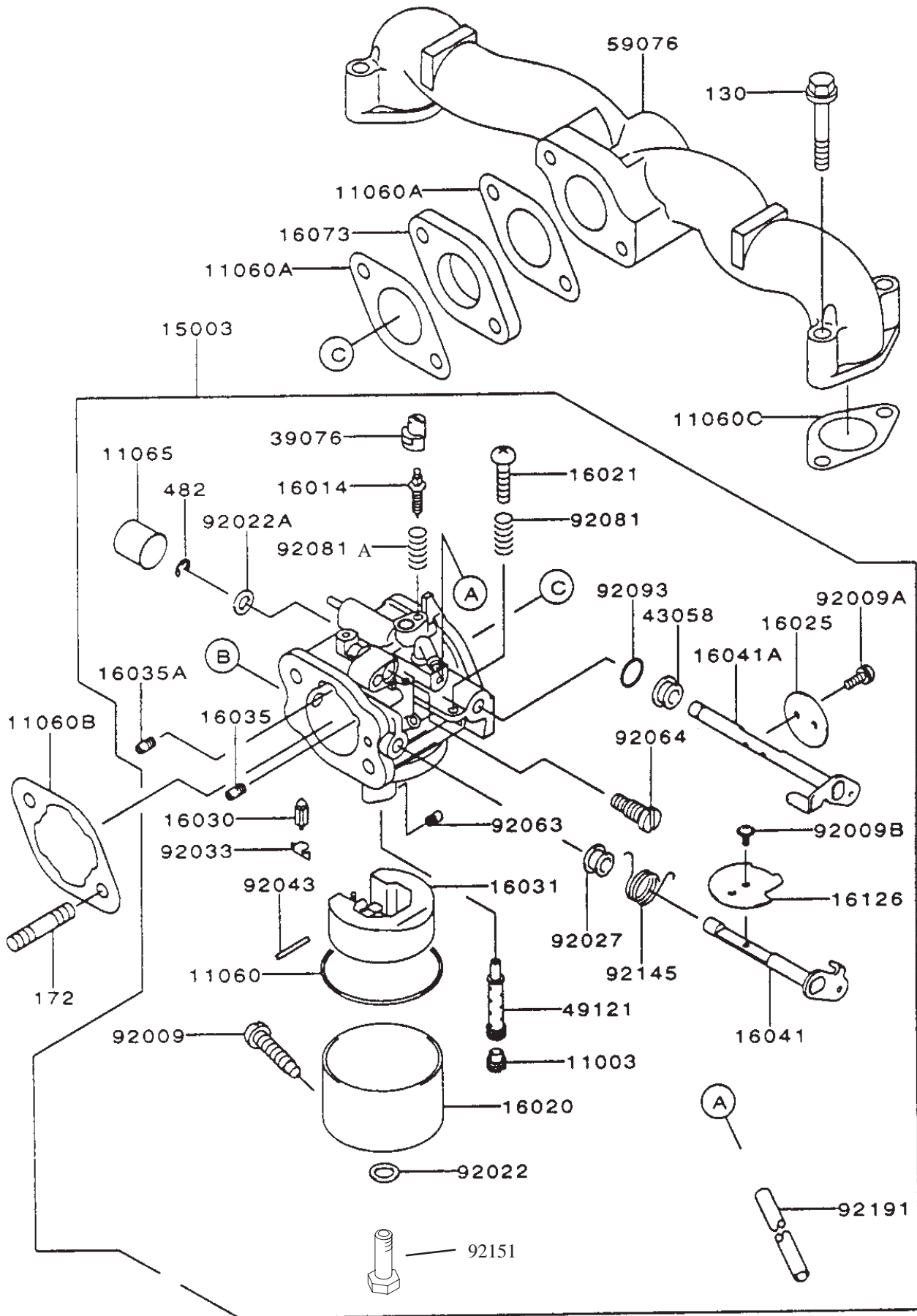

Carburetor Assembly Kawasaki FH500V-AS25

Ref. No.	Part No.	Qty.	Description	Ref. No.	Part No.	Qty.	Description
11003	11003-2105	1	Seat-Valve				
11060	11060-2406	1	Gasket				
11060A	11060-7003	2	Gasket, Insulator				
11060B	11060-7004	1	Gasket, Air Filter				
11060C	11060-7005	2	Gasket				
11065	11065-2061	1	Cap				
15003	15003-2698	1	Carburetor-Assy				
16014	16014-2080	1	Screw-Pilot Air				
16020	16020-2141	1	Chamber-Float				
16021	16021-2060	1	Screw-Throttlestop				
16025	16025-2193	1	Valve-Throttle, #130				
16030	16030-2067	1	Valve-Float				
16031	16031-2066	1	Float				
16035	16035-2060	1	Jet-Air, #1.7				
16035A	16035-2061	1	Jet-Air, #1.2				
16041	16041-2252	1	Shaft-Carburetor, Choke				
16041A	16041-2253	1	Shaft-Carburetor Throttle				
16073	16073-7001	1	Insulator				
16126	16126-2219	1	Valve				
39076	39076-2053	1	Limiter				
43058	43058-3716	1	Ring				
49121	49121-2222	1	Nozzle-Main				
59076	59076-7001	1	Manifold-Intake				
92009	92009-2015	1	Screw				
92009A	92009-2024	2	Screw				
92009B	92009-2081	1	Screw				
92022	92022-2231	1	Washer				
92022A	92022-2239	1	Washer				
92027	92027-2025	1	Collar				
92033	92033-2067	1	Ring-Snap				
92043	92043-2226	1	Pin				
92063	92063-2358	1	Jet-Main				
92064	92064-2125	1	Jet-Pilot				
92081	92081-2009	2	Spring				
92081A	92081-2256	1	Spring				
92093	92093-2002	1	Seal				
92145	92145-2061	1	Spring				
92151	92151-2092	1	Bolt				
92191	92191-7008	1	Tube				
130	130B0635	4	Bolt-Flanged				
172	172G0685	2	Bolt-Stud				
482	482L4000	1	Circlip-Type-E				

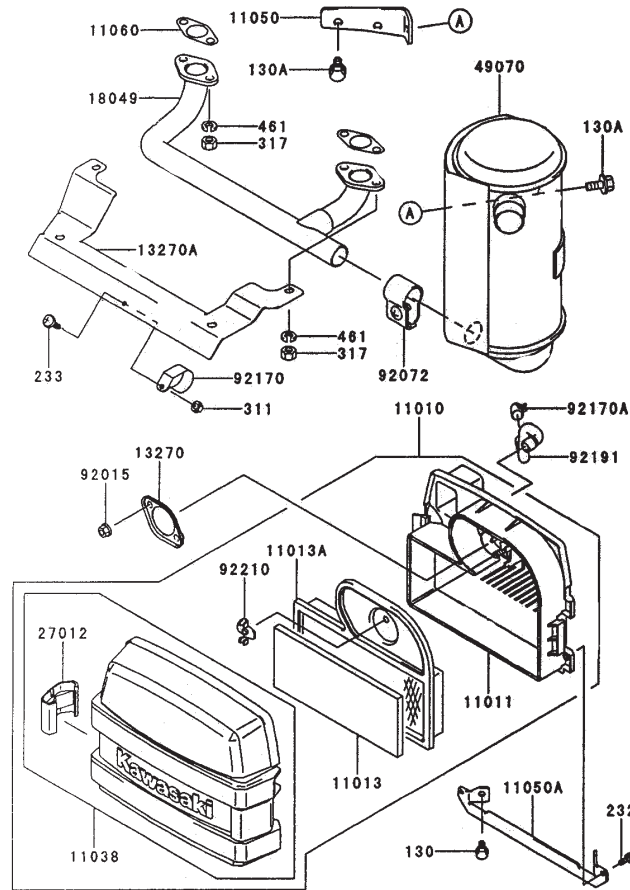

Air-Filter/Muffler Assembly Kawasaki FH500V-AS25

Ref. No.	Part No.	Qty.	Description
11010	11010-7001	1	Filter-Assy-Air
11011	11011-7001	1	Case-Air Filter
11013	11013-7001	1	Element-Air Filter
11013A	11013-7002	1	Element-Air Filter
11038	11038-7001	1	Case-Assy-Air Filter
11050	11050-7004	1	Bracket
11050A	11050-7006	1	Bracket
11060	11060-7006	2	Gasket, Muffler
13270	13270-7001	1	Plate
13270A	13270-7008	1	Plate
18049	18049-7001	1	Pipe-Exhaust
27012	27012-7001	2	Hook, Air Filter
49070	49070-7002	1	Muffler-Comp
92072	92072-7002	1	Band
92015	92015-1193	2	Nut
92170	92170-7002	1	Clamp
92170A	92170-7003	1	Clamp
92191	92191-7001	1	Tube
92210	92210-7004	1	Nut
130	130B0612	2	Bolt-Flanged
130A	130B0816	2	Bolt-Flanged
232	232B0514	2	Screw-Pan-WS
233	233B0416	1	Screw-Pan WP
311	311B0400	1	Nut-Hex
317	317R0800	4	Nut-Hex-Small

Ref. No.	Part No.	Qty.	Description
461	461F0800	4	Washer-Spring

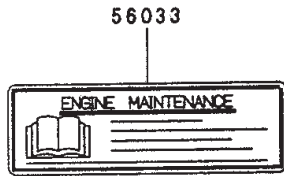
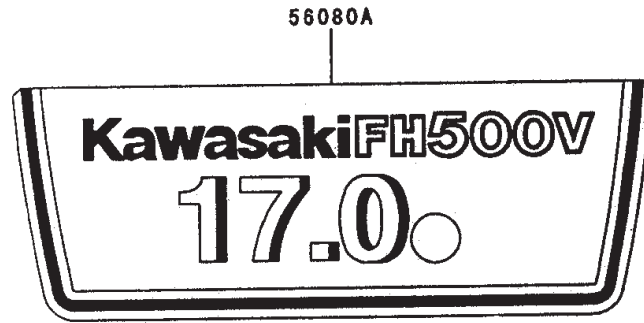

Starter/Decals – Kawasaki FH500V-AS25

Ref. No.	Part No.	Qty.	Description
56033	56033-7001	1	Label-Manual
56080	56080-2077	1	Label-Brand
56080A	56080-7001	1	Label-Brand

Ref. No.	Part No.	Qty.	Description

Electrical Schematic

Name	AWG	COLOR	Component	Pin
W1	GPT16PK	PINK	P3	2
W4	GPT16BK	BLACK	P1	1
W5	GPT18BK	BLACK	P4	2
W6	GPT16GN	GREEN	P5	3
W8	GPT16PK	PINK	P6	4
W10	GPT18BN	BROWN	J4	1
W11	GPT18OR	ORANGE	P5	1
W12	GPT18OR	ORANGE	P5	1
W13	GPT16BK	BLACK	P1	1
W14	GPT16PK	PINK	P3	1
W15	GPT16W	WHITE	J7	1
W16	GPT18BK	BLACK	P5	4

