



# Z-Recycler<sup>®</sup> Kit

## 62" Side Discharge Mower Attachment

Part No. 100–9600

## Parts Catalog

### Ordering Replacement Parts

To order replacement parts, please supply: the part number, the quantity, and the description of each part desired.

### Understanding Reference Numbers

Each identified part in an illustration has a reference number. The reference number for a part also appears in the parts list, along with other information about the part.

This catalog uses two special reference number formats, one to indicate parts in a service assembly and another to indicate the quantity of a given part in an illustration.

### Service Assembly Reference Numbers

Parts in service assemblies have reference numbers in the form **a:b**. The **a** represents the reference number of the entire service assembly and the **b** represents a sequential number unique to each part within the service assembly.

For example, a wheel assembly might be identified by reference number **6**, the tire by **6:1**, the valve by **6:2**, and the wheel by **6:3**. When you order the assembly identified by reference number **6**, you receive all parts identified by reference numbers **6:1**, **6:2**, and **6:3**. However, you may also order any part individually.

Reference numbers of this type appear in illustrations and in part lists.

### Reference Numbers Indicating Quantity

In an illustration, if a reference number indicates more than one part, the reference number has the form **nX y**. The **n** represents the quantity of the part, the **X** is the multiplication symbol, and the **y** represents the reference number.

For example, in an illustration, the reference number **2X 37** means that two of the parts identified by reference number **37** are indicated.

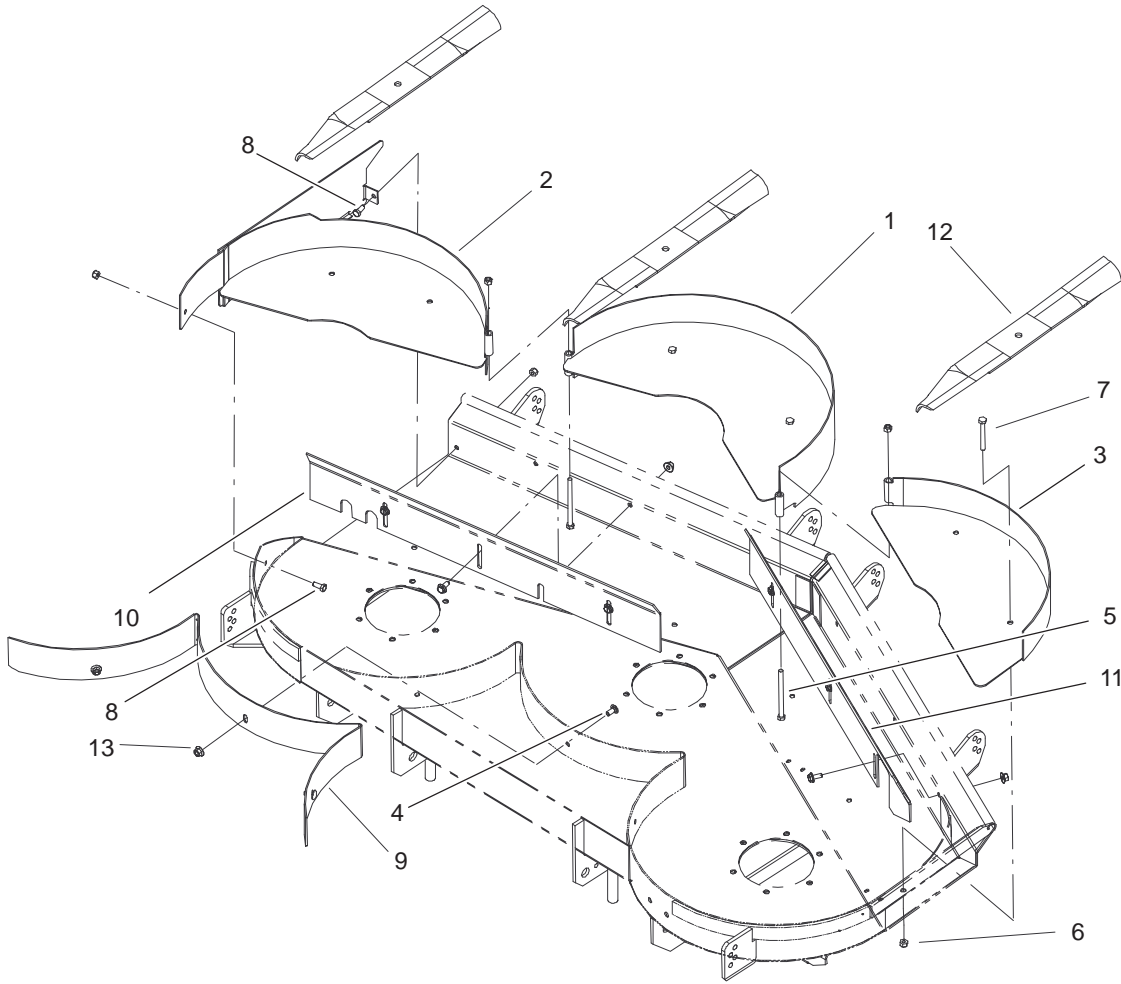

Sheet No.: 0

## Recycler Assembly

Ref. No.	Part No.	Qty.	Description
1	100-9608-03	1	Center Baffle ASM
2	100-9607-03	1	Right Baffle ASM
3	100-9609-03	1	Left Baffle ASM
4	3230-1	3	Screw-CARR
5	322-38	2	Screw-HH
6	3296-29	10	Nut-Lock
7	322-13	6	Screw-HH
8	322-3	2	Screw-HH
9	100-9680-03	1	Baffle-Center
10	104-4568-03	1	Baffle - Front, RH
11	104-4567-03	1	Baffle - Front, LH
12	100-9659	3	Blade
13	32128-20	3	Nut-HF

Ref. No.	Part No.	Qty.	Description