



## Mid-Size Mower

### ProLine Gear 13HP with 32" Side Discharge Mower

Model No. 30252—210000001 and Up

## Parts Catalog

### Ordering Replacement Parts

To order replacement parts, please supply: the part number, the quantity, and the description of each part desired.

### Understanding Reference Numbers

Each identified part in an illustration has a reference number. The reference number for a part also appears in the parts list, along with other information about the part.

This catalog uses two special reference number formats, one to indicate parts in a service assembly and another to indicate the quantity of a given part in an illustration.

### Service Assembly Reference Numbers

Parts in service assemblies have reference numbers in the form **a:b**. The **a** represents the reference number of the entire service assembly and the **b** represents a sequential number unique to each part within the service assembly.

For example, a wheel assembly might be identified by reference number **6**, the tire by **6:1**, the valve by **6:2**, and the wheel by **6:3**. When you order the assembly identified by reference number **6**, you receive all parts identified by reference numbers **6:1**, **6:2**, and **6:3**. However, you may also order any part individually.

Reference numbers of this type appear in illustrations and in part lists.

### Reference Numbers Indicating Quantity

In an illustration, if a reference number indicates more than one part, the reference number has the form **nX y**. The **n** represents the quantity of the part, the **X** is the multiplication symbol, and the **y** represents the reference number.

For example, in an illustration, the reference number **2X 37** means that two of the parts identified by reference number **37** are indicated.

## Contents

<b>Description</b>	<b>Page</b>	<b>Description</b>	<b>Page</b>
Fuel Tank and Idler Bracket Assembly . . . . .	3	Oil Pan / Lubrication (Kohler CV13T–PS–21524)	14
Transmission and Idler Pulley Assembly . . . . .	4	Cylinder Head, Valves And Breather (Kohler CV13T–PS–21524) . .	15
Brake, Wheel Pulley and Wheel Assembly . . . .	5	Ignition / Electrical (Kohler CV13T–PS–21524)	16
Handle and Control Panel Assembly . . . . .	6	Blower Housing And Baffles (Kohler CV13T–PS–21524) . . . .	17
Engine Assembly . . . . .	7	Starter System (Kohler CV13T–PS–21524) . .	18
Clutch/Brake Assembly No. 54–3200 . . . . .	8	Fuel System (Kohler CV13T–PS–21524) . . . .	19
Carrier Frame Assembly . . . . .	9	Engine Controls (Kohler CV13T–PS–21524) . .	20
Deck Assembly . . . . .	10	Air Cleaner (Kohler CV13T–PS–21524) . . . . .	21
Spindle Assembly . . . . .	11	Exhaust (Kohler CV13T–PS–21524) . . . . .	22
Decal and Mulcher Cover Assembly . . . . .	12		
Crankcase (Kohler CV13T–PS–21524) . . . . .	13		

## Part Description Abbreviations

Part descriptions in this catalog may include the following abbreviations.

<b>Abbreviation</b>	<b>Meaning</b>	<b>Abbreviation</b>	<b>Meaning</b>
AR . . . . .	as required	HYD . . . . .	hydraulic
ASM . . . . .	assembly	INC . . . . .	incorporated
CARR . . . . .	carriage	LH . . . . .	left hand
DEG . . . . .	degrees	NI . . . . .	nylon insert
FH . . . . .	flat head	PPH . . . . .	Phillips pan head
GA . . . . .	gauge	PTH . . . . .	Phillips truss head
HF . . . . .	hex flange	PTO . . . . .	power take off
HH . . . . .	hex head	RH . . . . .	right hand
HHF . . . . .	hex head flange	SFH . . . . .	slotted fillister head
HLH . . . . .	hex lag head	SHH . . . . .	slotted hex head
HJ . . . . .	hex jam	SQH . . . . .	square head
HOC . . . . .	height-of-cut	SHWH . . . . .	slotted hex washer head
HS . . . . .	hex socket	SPH . . . . .	slotted pan head
HSBH . . . . .	hex socket button head	SRH . . . . .	slotted round head
HSFH . . . . .	hex socket flat head	STD . . . . .	standard
HSH . . . . .	hex socket head	TAP . . . . .	self tapping
HWH . . . . .	hex washer head	TTH . . . . .	Torx truss head
HWHTF . . . . .	hex washer head thread forming	WH . . . . .	wing head



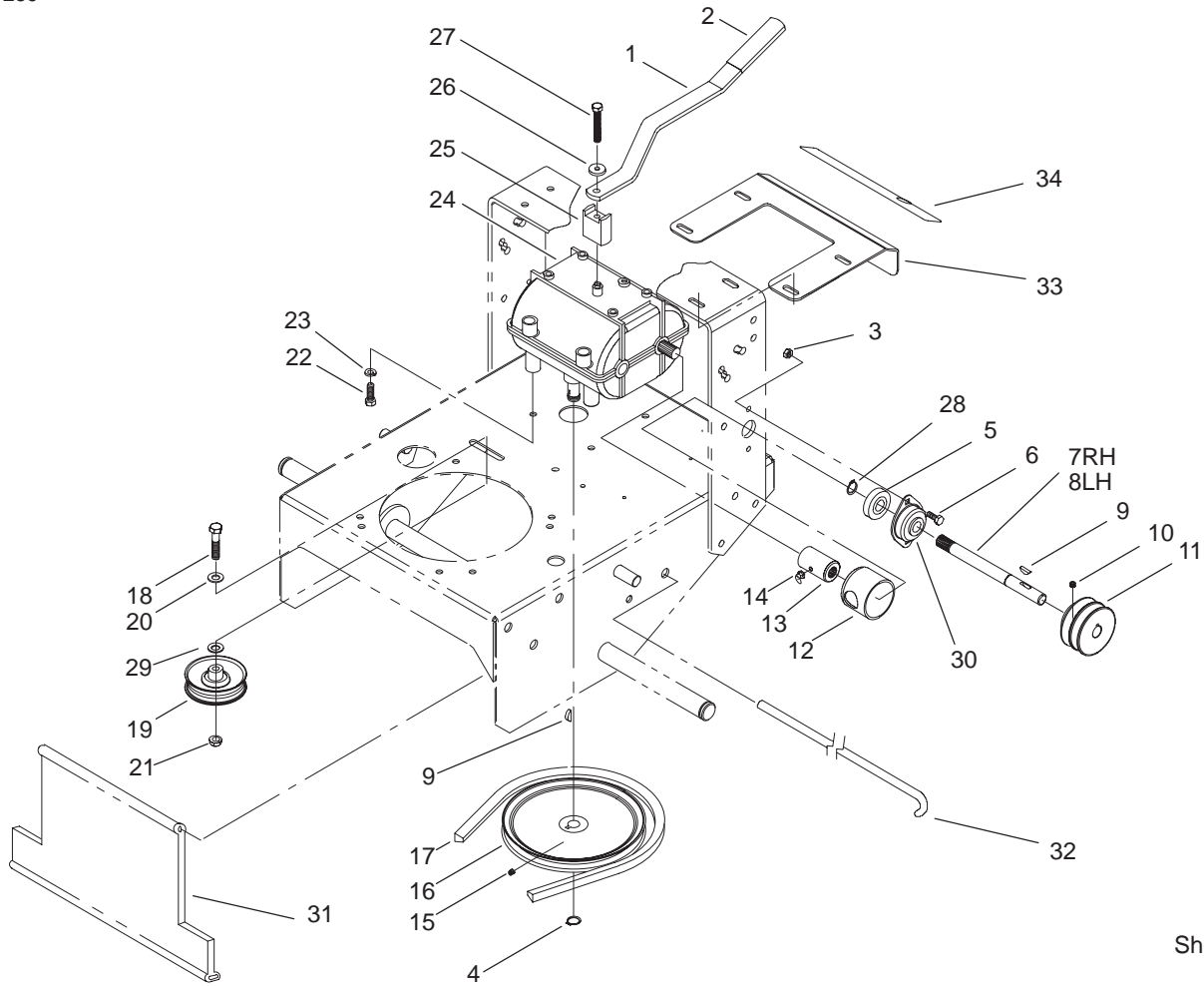

Sheet No.:3

## Transmission and Idler Pulley Assembly

Ref. No.	Part No.	Qty.	Description
1	74-0320-01	1	Lever-Shift
2	47-1970	1	Grip-Engagement
3	3296-42	4	Nut-Lock, NI
4	32120-64	1	Ring-Snap, External
5	1-323252	2	Bearing-Shaft, Transmission
6	321-4	4	Screw-HH
7	98-0788	1	Shaft-Extension, RH
8	98-0787	1	Shaft-Extension, LH
9	3257-5	3	Key-Woodruff
10	3245-3	2	Screw-Hex Socket Set
11	74-0480	2	Drive Pulley Assembly
12	51-4220	2	Guard-Coupler
13	98-0789	2	Coupler
14	302-5	2	Fitting-Grease
15	3245-1	1	Screw-Set, HSH
16	51-4190	1	Pulley-Driven
17	26-9671	1	V-Belt
18	323-9	1	Screw-HH
19	51-4810	1	Pulley-Idler
20	3256-24	1	Washer-Flat
21	32128-21	1	Nut-HF
22	322-2	4	Screw-HH
23	3253-4	4	Washer-Lock
24	98-0791	1	Transmission

Ref. No.	Part No.	Qty.	Description
25	72-2190	1	Mount-Shift Lever
26	7-5461	1	Spacer
27	329-10	1	Screw-HH
28	32151-62	2	Ring-Retaining
29	3256-24	1	Washer-Flat
30	1-323254	2	Flange-Output
31	95-1526	1	Shield-Trailing
32	95-1529	1	Rod-Shield
33	104-8552	1	Plate-Control
34	82-7750	1	Decal-Ground Speed

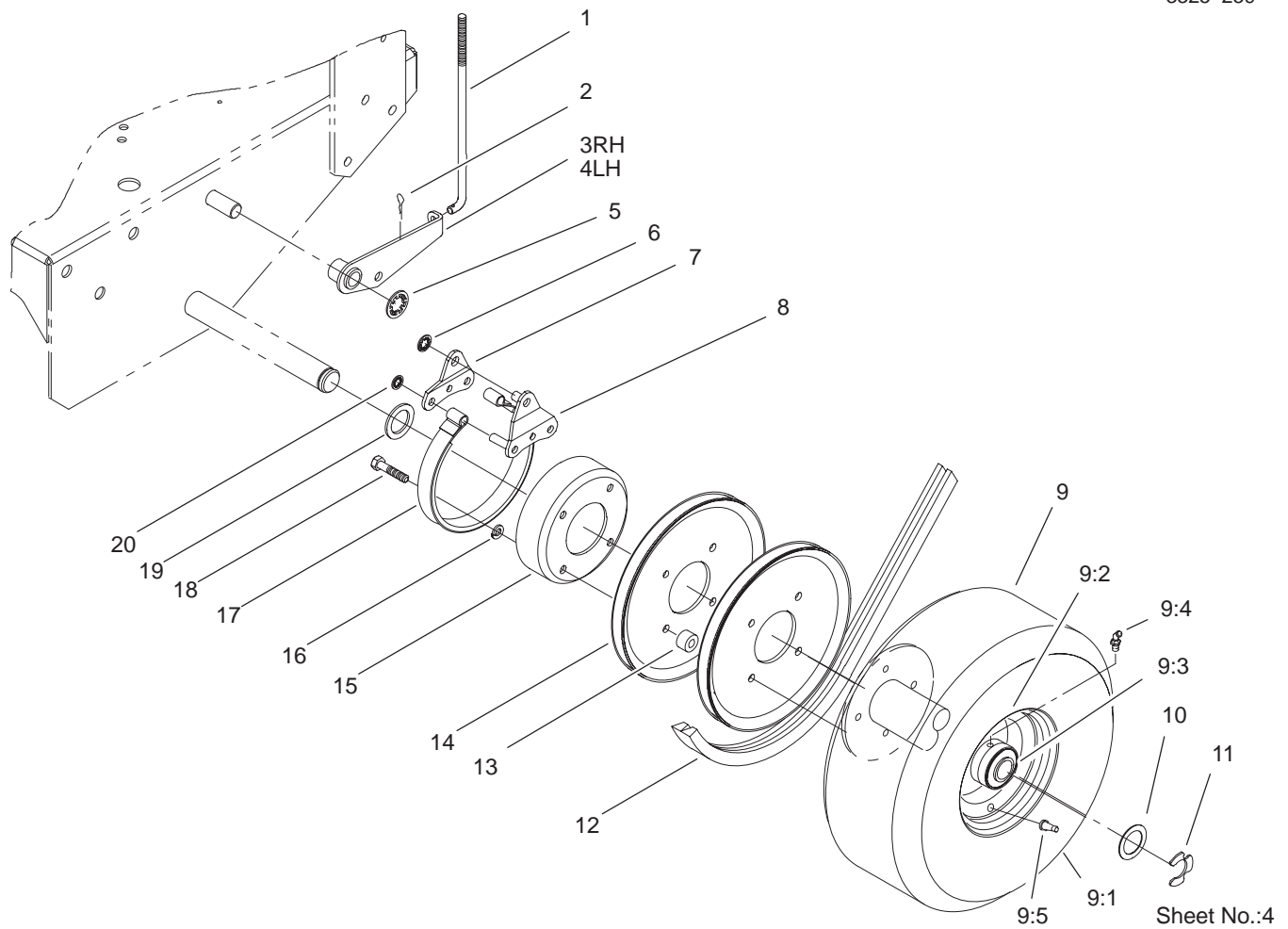

## Brake, Wheel Pulley and Wheel Assembly

Ref. No.	Part No.	Qty.	Description
1	51-4580	2	Rod-Brake
2	3290-307	2	Pin-Hair
3	67-6400-01	1	Arm-Brake, RH
4	67-6420-01	1	Arm-Brake, LH
5	32151-40	2	Ring-Retaining
6	32151-56	2	Ring-Retaining, External
7	51-4660-01	2	Plate-Brake Link
8	51-4650-01	2	Link-Brake
9	93-1163	2	Wheel & Tire Assembly
9:1	231-94	2	Tire-Front
9:2	93-1181	2	Wheel ASM
9:3	92-1746	4	Bearing-Ball
9:4	302-57	2	Fitting-Grease
9:5	232-27	2	Stem-Valve
10	10-8110	8	Washer-Thrust
11	32151-91	2	Ring-Retaining
12	51-4291	2	V-Belt
13	51-4170	8	Spacer-Pulley
14	51-4160-03	4	Pulley-Wheel
15	51-4180-03	2	Drum-Brake
16	3253-4	8	Washer-Lock
17	51-4700	2	Band-Brake
18	322-7	8	Screw-HH
19	51-4230	2	Washer-Wheel
20	32151-72	4	Ring-Retaining

Ref. No.	Part No.	Qty.	Description

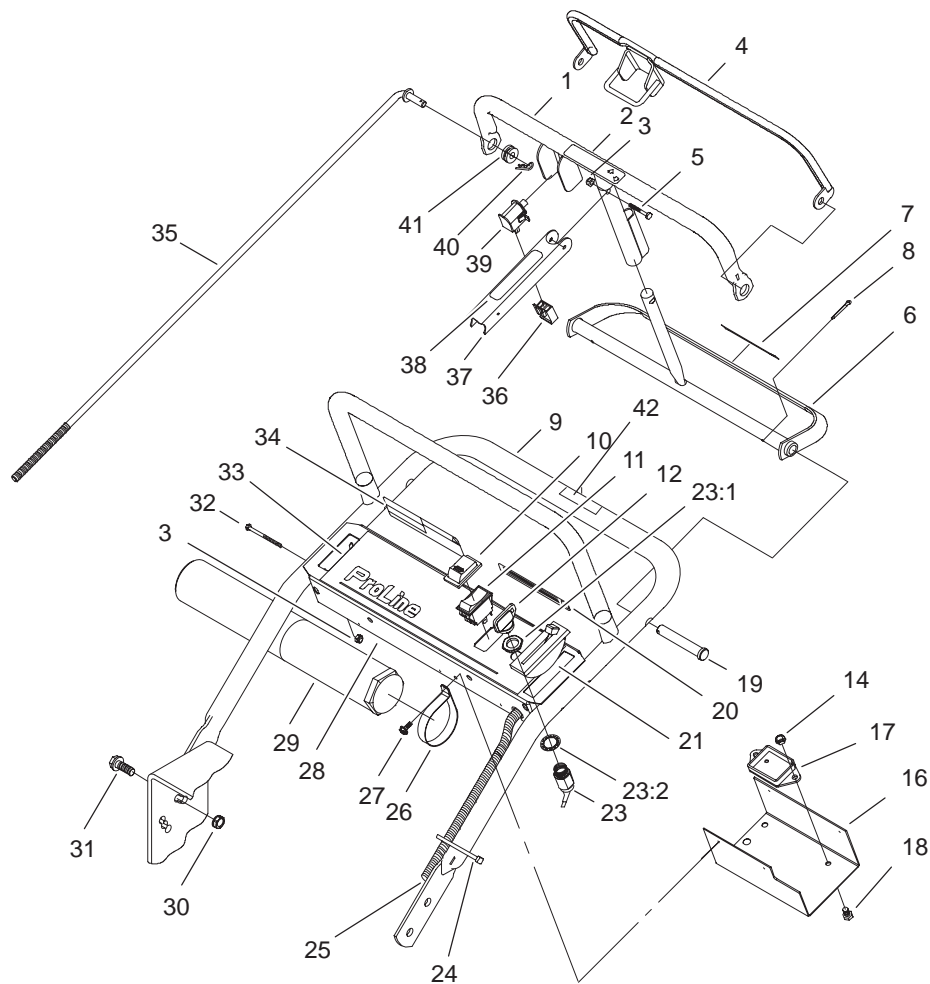

Sheet No.:5

## Handle and Control Panel Assembly

Ref. No.	Part No.	Qty.	Description
1	82-7690-03	1	Bar-Control
2	82-2290	1	Decal-Control Bar
3	3296-2	5	Nut-Lock
4	82-7680-03	1	Bail
5	32105-1	1	Screw-Shh
6	99-8501-03	1	Control-Pivot
7	82-2280	1	Decal-Reverse Handle
8	3272-11	2	Pin-Cotter
9	67-6440-01	1	Handle-Upper
10	82-3820	1	Boot-Switch
11	82-2300	1	Switch
12	63-8360	2	Key-Ignition
14	3296-42	1	Nut-Lock, NI
16	93-1187-03	1	Panel-Bottom
17	100-6170	1	Module-Delay
18	321-2	1	Screw-HH
19	283-55	2	Pin-Clevis
20	65-3090	1	Decal-Instruction
21	74-0630	1	Control-Throttle
23	29-5560	1	Switch-On Off
23:1	218-461	1	Nut-HH
23:2	3254-5	1	Washer-Lock, Internal
24	3290-378	2	Tie-Cable
25	100-3284	1	Harness-Wire, Recoil
26	2412-120	2	R-Clamp

Ref. No.	Part No.	Qty.	Description
27	32104-76	4	Screw
28	82-2180-03	1	Panel-Control
29	74-0720	1	Tube-Manual
30	32128-21	4	Nut-HF
31	3234-11	4	Screw-HHF
32	32105-14	4	Screw
33	82-7730	1	Decal-Control Panel
34	71-1280	1	Decal-Instruction, Safety
35	82-7632	2	Rod-Control
36	218-595	1	Connector-Body
37	51-4850-03	1	Lever-Parking Brake
38	52-2010	1	Decal-Parking Lever
39	82-2190	1	Switch-Bail
40	3290-307	2	Pin-Hair
41	237-141	2	Grommet-Rubber
42	98-4387	1	Decal-Protection, Ear

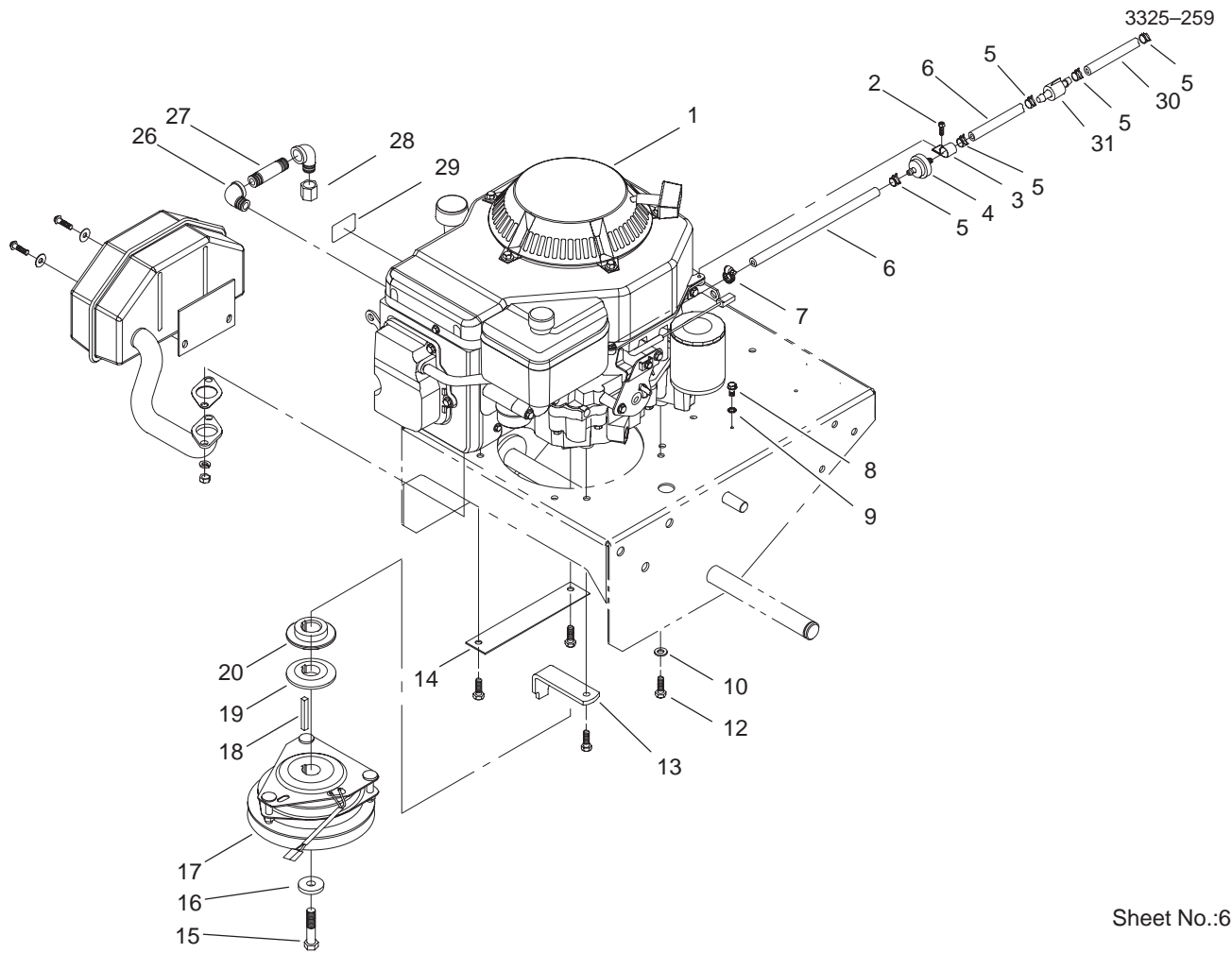

Sheet No.:6

## Engine Assembly

Ref. No.	Part No.	Qty.	Description
1		1	Engine-Kohler, Cv13t-Ps-21524
2	32144-19	1	Screw-Thread Forming
3	2412-87	1	Clamp-Cable
4	56-6360	1	Filter-Fuel
5	2412-98	5	Clamp
7	2412-108	1	Clamp-Worm
8	12-3270	1	Screw
9	3255-7	1	Washer-Lock/Ext
10	3256-23	1	Washer-Flat
12	33114-025	4	Screw-HH
13	51-4540-03	1	Retainer-Clutch
14	74-0930-01	1	Guard-Pulley
15	3212-9	1	Screw-HH
16	112843	1	Washer
17	54-3200	1	Clutch/Brake
18	608006	1	Key
19	74-0050	1	Sheave-Lower Half
20	74-0060	1	Sheave-Upper Half
26	74-0950	2	Elbow-Street, 90°
27	289-20	1	Nipple-Pipe
28	288-4	1	Cap-Pipe
29	63-8440	1	Decal-Hot Surface
31	1-603770	1	Valve-Fuel

Ref. No.	Part No.	Qty.	Description

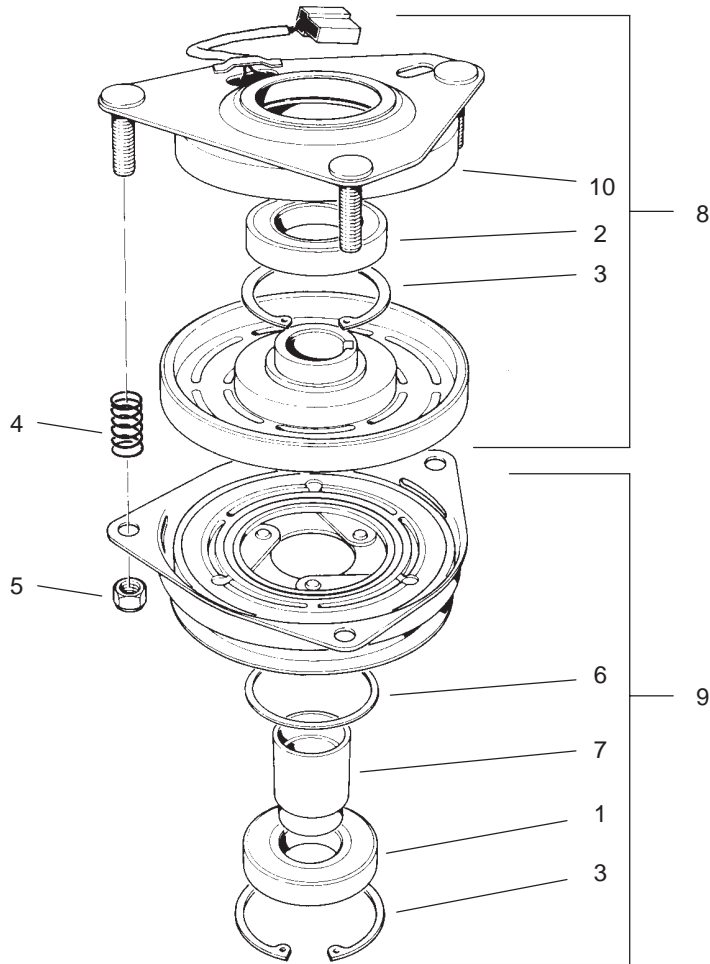

Sheet No.:A1  
T-3726

### Clutch/Brake Assembly No. 54-3200

Ref. No.	Part No.	Qty.	Description
1	251-291	1	Bearing-Pulley
2	251-292	1	Bearing-Field
3	44-8310	2	Ring-Retaining
4	44-8320	3	Spring
5	3296-6	3	Nut-Lock, NI
6	44-8330	1	Spacer-Pulley Bearing
7	44-8340	1	Collar-Bearing
8	44-8360	1	Field Coil-Rotor / Bearing ASM
9	44-8370	1	Armature / Pulley / Bearing ASM
10	54-0230	1	Field Bearing ASM

Ref. No.	Part No.	Qty.	Description









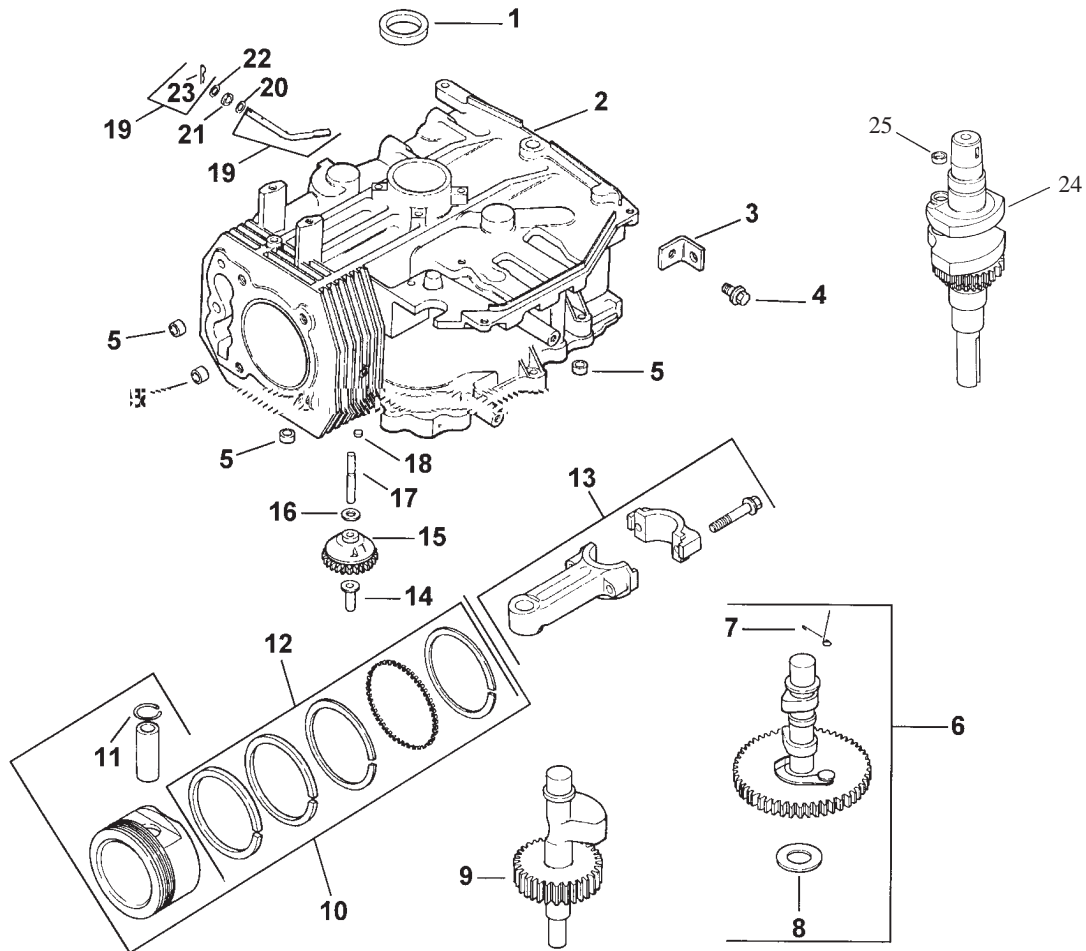

## Crankcase Assembly (Kohler CV13T-PS-21524)

Ref. No.	Part No.	Qty.	Description	Ref. No.	Part No.	Qty.	Description
1	12 032 03	1	Seal-Crankshaft	14	12 380 01	1	Pin-Governor Regulating
2	12 522 33	1	Shortblock	15	12 043 05	1	Gear-Governor ASM
3	12 445 02	1	Strap-Lifting	16	M-0631005	1	Washer-Governor
4	M-0839025	1	Screw M8x1.25x22	17	12 144 02	1	Shaft-Governor Gear
5	12 380 17	4	Dowel-Locating	18	52 139 09	1	Plug-Cup
6	12 755 49	1	Kit-Camshaft INC 7-8	19	12 755 64	1	Kit - Shaft-Governor Cross (Incl. Ref.#23)
7	12 089 31	1	Spring-Actuating	20	X-25-102	1	Washer-Flat
8	12 422 07	A/R	Shim-Camshaft A/R	21	12 032 01	1	Seal-Governor Shaft
8	12 422 08	1	Shim-Camshaft A/R	22	M-0631015	1	Washer-Governor Shaft
8	12 422 09	A/R	Shim-Camshaft A/R	23	12 154 05	1	Clip - Hitch Pin
8	12 422 10	A/R	Shim-Camshaft A/R	24	12 014 30	1	Crankshaft ASM
8	12 422 11	A/R	Shim-Camshaft A/R	25	12 139 01	1	Plug-Cup
8	12 422 12	A/R	Shim-Camshaft A/R	*	12 030 02	1	Bearing - Crankshaft 0.25
8	12 422 13	A/R	Shim-Camshaft A/R	*	12 030 03	1	Bearing - Crankshaft 0.50
9	12 144 27	1	Shaft-Balance	*	12 755 83	1	Set - Gasket
10	12 847 01	1	Set Piston w/Ring STD				
10	12 847 02	1	Set-Piston w/Ring .25				
10	12 847 03	1	Set-Piston w/Ring .50				
11	12 018 02	2	Retainer-Piston Pin				
12	12 108 01	1	Ring Set STD				
12	12 108 02	1	Ring Set .25				
12	12 108 03	1	Ring Set .50				
13	12 067 05	1	Rod Connecting STD				
13	12 067 06	1	Rod Connecting .25				

\* Not Illustrated

Obtain parts from Kohler

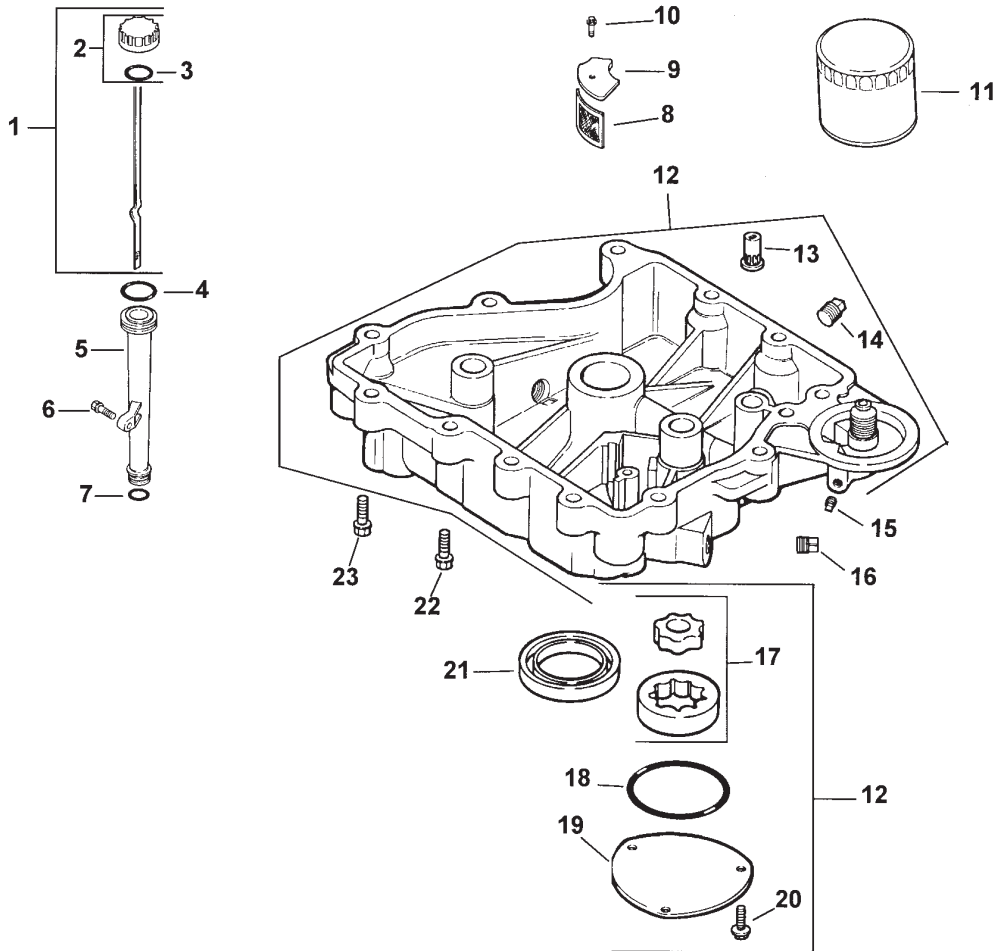

Sheet No.: 2 02

## Oil Pan / Lubrication (Kohler CV13T-PS-21524)

Ref. No.	Part No.	Qty.	Description
1	12 038 01	1	Dipstick INC 2-3
2	25 755 13	1	Kit-Oil Cap INC 3
3	12 153 03	1	O Ring-Fill Cap
4	12 153 02	1	O Ring-Upper Fill Tube
5	12 123 04	1	Tube-Oil Fill
6	M-0545020	1	Screw M5x0.8x20
7	12 153 01	2	O Ring-Lower Fill Tube
8	25 162 07	1	Screen-Oil
9	12 096 03	1	Cover-Oil Pickup Screen
10	M-0545016	1	Screw M5x0.8x16
11	52 050 02	1	Filter-Oil
12	12 755 45	1	Pan - Oil (Incl. Ref. #13, 14, 17-20)
13	25 462 09	1	Valve - Oil Pressure
14	X-75-2	2	Plug-1/4nptf
15	X-75-1	2	Plug-1/8nptf
16	X-75-10	2	Plug-SH 3/8 NPTF
17	12 393 01	1	Pump-Oil
18	12 153 06	1	O Ring-Oil Pump Cover
19	12 096 34	1	Cover-Oil Pump
20	M-0545016	3	Screw M5x0.8x16
21	12 032 03	1	Seal-Crankshaft

Ref. No.	Part No.	Qty.	Description
22	24 086 16	11	Screw-M8X1.25X45
23	24 068 17	1	Screw-M5X1.25X45

\*Not illustrated  
**Obtain parts from Kohler**

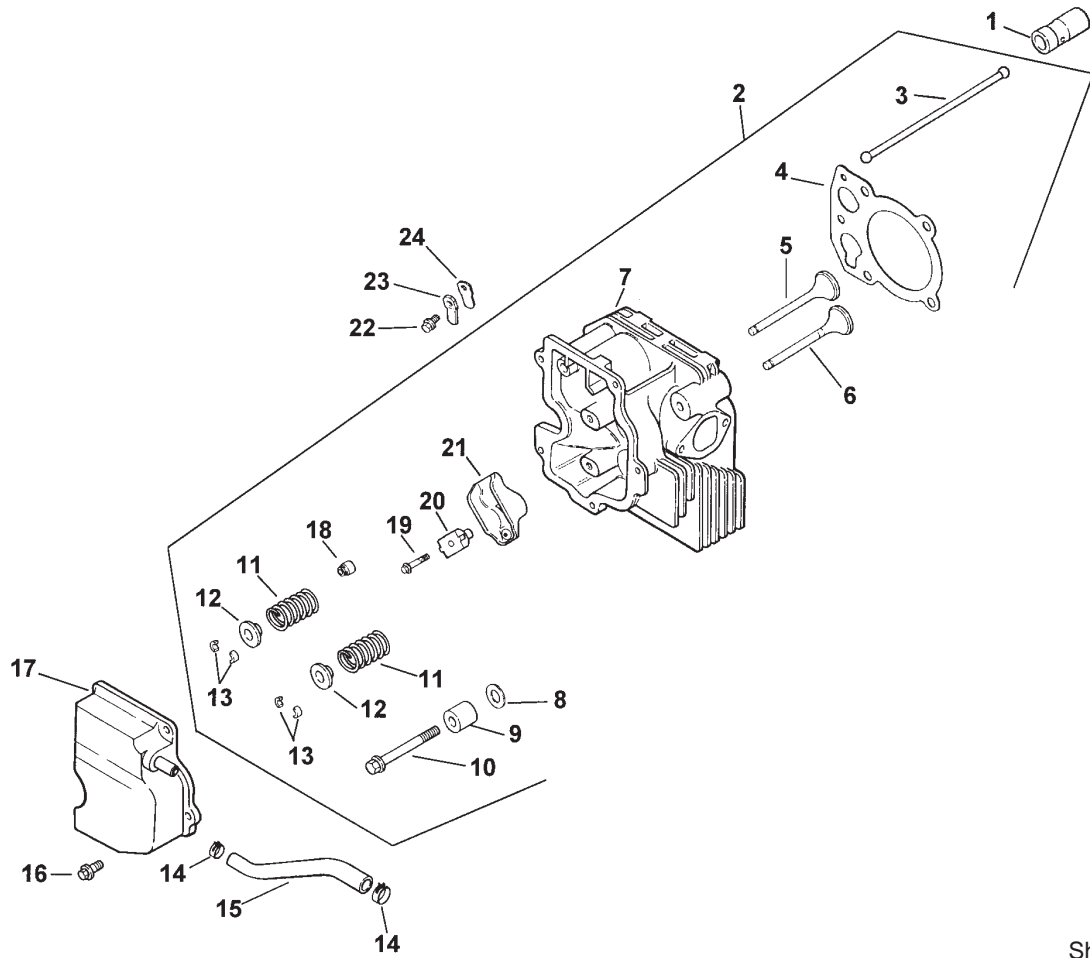

Sheet No.: 2 03

## Cylinder Head, Valves And Breather (Kohler CV13T-PS-21524)

Ref. No.	Part No.	Qty.	Description
1	12 351 02	2	Lifter-Valve
2	12 755 81	1	Kit-Cylinder Head
3	12 411 01	2	Rod-Push
4	12 041 08	1	Gasket-Cylinder Head
5	12 017 01	1	Valve-Intake STD
5	12 017 02	1	Valve-Intake .25
6	12 016 01	1	Valve-Exhaust STD
6	12 016 02	1	Valve-Exhaust .25
7	12 318 19	1	Head - Cylinder
8	12 468 05	1	Washer-Flat
9	12 112 13	1	Spacer-Head Bolt Exhaust
10	12 086 15	5	Screw M10x1.5x80
11	12 089 01	1	Spring-Valve
12	12 173 01	2	Cap-Valve Spring
13	12 755 03	2	Kit-Retainer
14	X-426-9	2	Clamp-Hose
15	12 326 03	1	Hose-Breather
16	M-0645020	3	Screw-HH M6x1.0x20
17	12 096 07	1	Cover-Valve w/Nipple
18	24 023 05	1	Seal-Valve Spring
19	M-0640034	2	Screw M6x1.0x34
20	12 599 03	2	Pivot - Rocker Arm
21	25 186 01	2	Arm-Rocker

Ref. No.	Part No.	Qty.	Description
22	M-0545010	1	Screw M5x0.8x10
23	12 018 01	1	Retainer-Breather Reed
24	12 402 02	1	Reed-Breather

\*Not illustrated

**Obtain parts from Kohler**

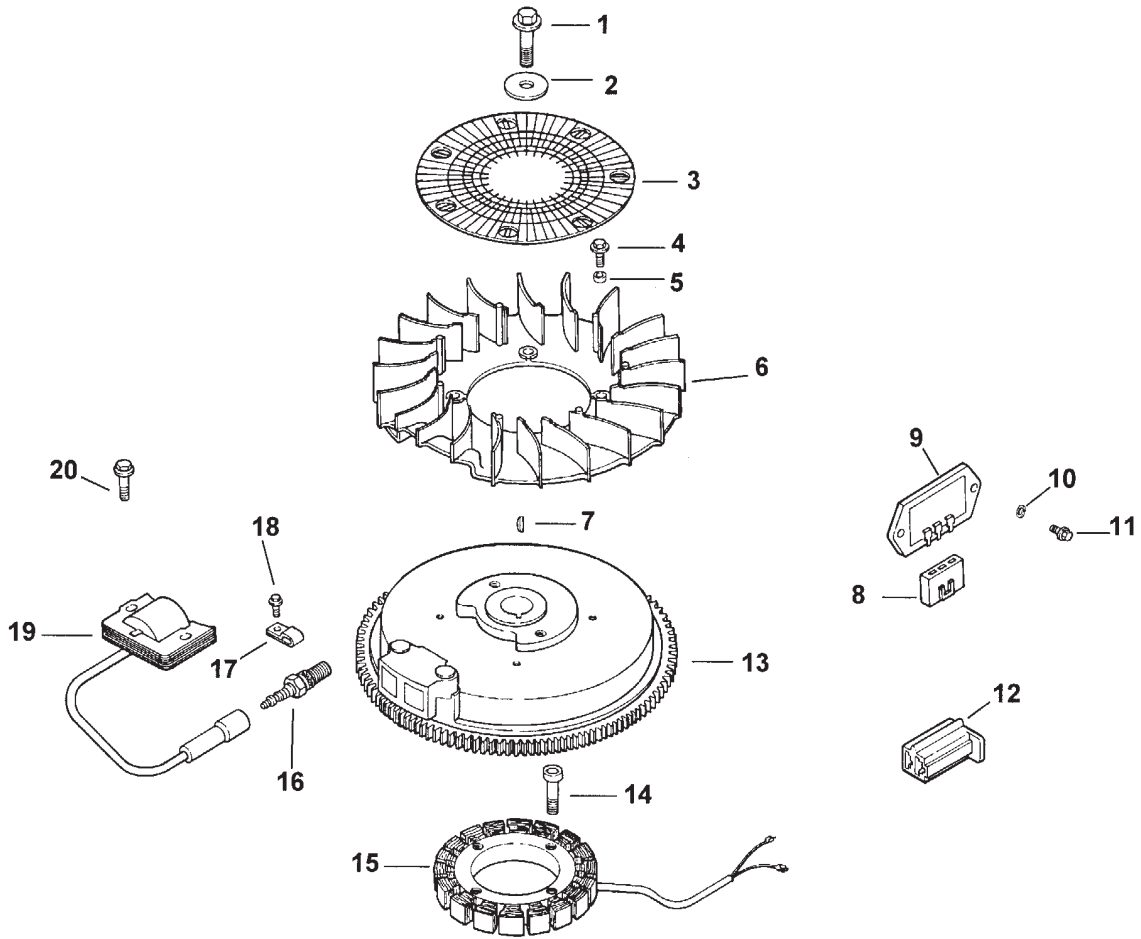

Sheet No.: 2 04

## Ignition / Electrical (Kohler CV13T-PS-21524)

Ref. No.	Part No.	Qty.	Description
1	12 086 14	1	Screw-Flywheel Mounting
2	12 486 03	1	Washer-Flat
3	12 162 03	1	Screen-Grass
4	M-0639016	4	Screw M6x1.0x16
5	12 112 01	4	Spacer-Fan
6	12 157 02	1	Fan
7	X-42-15	1	Key
8	236602	1	Connector-Regulator
9	12 403 01	1	Rectifier-Unregulated
10	X-22-11	2	Washer - Lock
11	M-0639016	2	Screw M6x1.0x16
12	41 155 03	1	Connector
13	12 025 15	1	Flywheel ASM
14	M-0548025	4	Screw M5x0.8x25
15	54 755 09	1	Kit - Stator-15 Amp (Incl. Bracket P/N #24 126 71)
16	12 132 02	1	Spark Plug
17	X-728-1	2	Clip-Kill Lead
18	M-0545010	1	Screw M5x0.8x10
19	12 584 02	1	Module-Ignition
20	M-0545020	2	Screw M5x0.8x20
*	X-25-5	1	Washer
*	12 518 01	1	Lead-White
*	25 518 05	1	Lead-Black

Ref. No.	Part No.	Qty.	Description
*	25 518 29	1	Lead-Black
*	24 126 71	1	Bracket - Stator Wire

\* Not illustrated  
Obtain parts from Kohler















