



Ultra 225 Blower/Vacuum

Model No. 51598—210000001 and Up

Parts Catalog

Ordering Replacement Parts

To order replacement parts, please supply: the part number, the quantity, and the description of each part desired.

Understanding Reference Numbers

Each identified part in an illustration has a reference number. The reference number for a part also appears in the parts list, along with other information about the part.

This catalog uses two special reference number formats, one to indicate parts in a service assembly and another to indicate the quantity of a given part in an illustration.

Service Assembly Reference Numbers

Parts in service assemblies have reference numbers in the form **a:b**. The **a** represents the reference number of the entire service assembly and the **b** represents a sequential number unique to each part within the service assembly.

For example, a wheel assembly might be identified by reference number **6**, the tire by **6:1**, the valve by **6:2**, and the wheel by **6:3**. When you order the assembly identified by reference number **6**, you receive all parts identified by reference numbers **6:1**, **6:2**, and **6:3**. However, you may also order any part individually.

Reference numbers of this type appear in illustrations and in part lists.

Reference Numbers Indicating Quantity

In an illustration, if a reference number indicates more than one part, the reference number has the form **nX y**. The **n** represents the quantity of the part, the **X** is the multiplication symbol, and the **y** represents the reference number.

For example, in an illustration, the reference number **2X 37** means that two of the parts identified by reference number **37** are indicated.

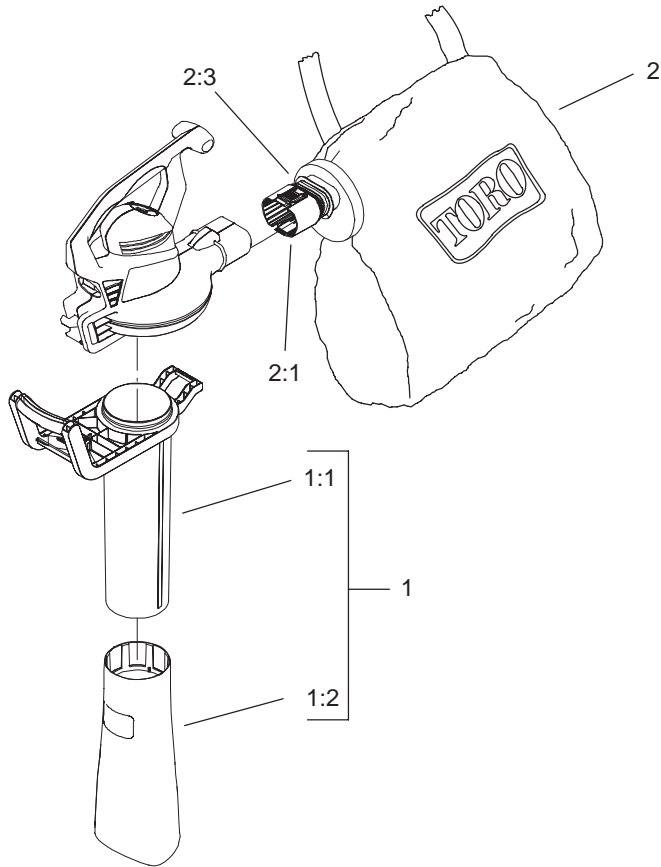

Sheet No.:3

Vacuum Tube and Bag Assembly

Ref. No.	Part No.	Qty.	Description
☆1		1	Vac Tube ASM
1:1	100-9066	1	Tube-Vac, Upper
1:2	100-9074	1	Tube-Vac, Lower
2	104-3809	1	Bag ASM
2:1	100-9065	1	Collar-Bag
2:3	100-9064	1	Tie-Cable

Ref. No.	Part No.	Qty.	Description

☆ Not serviced separately

