



5, 7, 11 Blade Reel Mower Reelmaster[®] 5500 and 6000 Series

Model No. 03860—210000001 and Up

Model No. 03861—210000001 and Up

Model No. 03862—210000001 and Up

Parts Catalog

Ordering Replacement Parts

To order replacement parts, please supply: the part number, the quantity, and the description of each part desired.

Understanding Reference Numbers

Each identified part in an illustration has a reference number. The reference number for a part also appears in the parts list, along with other information about the part.

This catalog uses two special reference number formats, one to indicate parts in a service assembly and another to indicate the quantity of a given part in an illustration.

Service Assembly Reference Numbers

Parts in service assemblies have reference numbers in the form **a:b**. The **a** represents the reference number of the entire service assembly and the **b** represents a sequential number unique to each part within the service assembly.

For example, a wheel assembly might be identified by reference number **6**, the tire by **6:1**, the valve by **6:2**, and the wheel by **6:3**. When you order the assembly identified by reference number **6**, you receive all parts identified by reference numbers **6:1**, **6:2**, and **6:3**. However, you may also order any part individually.

Reference numbers of this type appear in illustrations and in part lists.

Reference Numbers Indicating Quantity

In an illustration, if a reference number indicates more than one part, the reference number has the form **nX y**. The **n** represents the quantity of the part, the **X** is the multiplication symbol, and the **y** represents the reference number.

For example, in an illustration, the reference number **2X 37** means that two of the parts identified by reference number **37** are indicated.

Contents

Description	Page	Description	Page
Reel and Frame Assembly	3	Shoulder Roller Assembly	
Rollers and Carrier Frame Assembly	5	No. 99-8675 (RM6000 Series)	9
Roller Assembly No. 99-5749	6	Guage Bar, Angle Indicator and	
Wiehle Roller Assembly No. 100-9906	7	Handle Assembly	10
Shoulder Roller Assembly			
No. 100-9911 (RM5500)	8		

Accessories

Description	Model / Part No.	Description	Model / Part No.
Basket Kit	03882	RM6000 Series Shoulder Scraper	99-8670-03
High Torque Hydraulic Motor	98-9998	RM5500 Shoulder Scraper	100-9913-03
Wiehle Scraper	100-9908-03	Rear Scraper Kit	100-9920
Rear Roller Brush Kit	03875	3" DIA Collar Kit	104-8215

Part Description Abbreviations

Part descriptions in this catalog may include the following abbreviations.

Abbreviation	Meaning	Abbreviation	Meaning
AR	as required	INC	incorporated
ASM	assembly	LH	left hand
CARR	carriage	NI	nylon insert
DEG	degrees	PPH	Phillips pan head
FH	flat head	PTH	Phillips truss head
GA	gauge	PTO	power take off
HF	hex flange	RH	right hand
HH	hex head	SFH	slotted fillister head
HHF	hex head flange	SHH	slotted hex head
HLH	hex lag head	SQH	square head
HJ	hex jam	SHWH	slotted hex washer head
HOC	height-of-cut	SPH	slotted pan head
HS	hex socket	SRH	slotted round head
HSBH	hex socket button head	STD	standard
HSFH	hex socket flat head	TAP	self tapping
HSH	hex socket head	TTH	Torx truss head
HWH	hex washer head	WH	wing head
HWHTF	hex washer head thread forming		

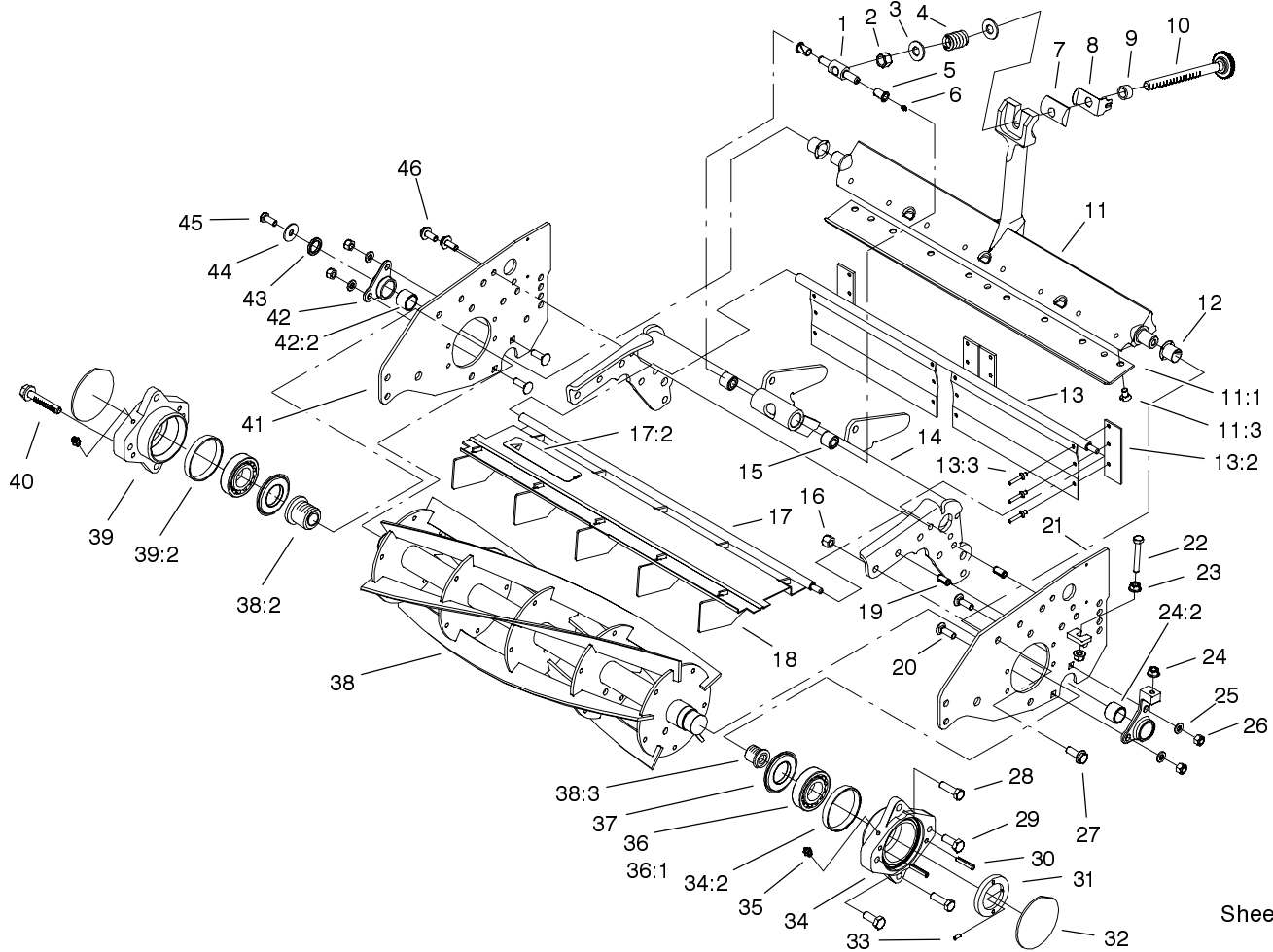

Sheet No.:2

T-3466

Reel and Frame Assembly

Ref. No.	Part No.	Qty.	Description	Ref. No.	Part No.	Qty.	Description
1	57-5260	1	Pivot-Bedbar	17:2	93-6688	1	Decal-Warning, Europe
2	3296-62	1	Nut-Lock NI	17:2	94-4584	1	Decal-Danger (Japan)
3	29-8910	2	Washer	18	100-2287	5	Deflector-Shield, Grass
4	95-0772	1	Spring - Compression	19	32121-36	4	Pin-Spring
5	52-2890	2	Bushing-Nylon	20	3230-2	4	Screw-CARR
6	302-18	1	Fitting-Grease	21	100-2268-01	1	LH Sideplate ASM
7	93-2892	1	Pivot-Bedbar, Main Adj	22	94-3489	1	Capscrew-HH
8	95-8752	1	Arm-Spring	23	33004-00	3	Nut-HF
9	93-2959	1	Spacer-Adjuster	24	100-3381	1	LH Pivot Hub ASM
10	95-8877	1	Bedbar Adjuster ASM	24:2	93-7501	1	Bushing ASM
11	99-8698-01	1	Bedbar - Machining	25	3256-74	4	Washer-Flat
11:1	98-3994	1	Bedknife	26	3296-29	4	Nut-Lock
*11:2	93-9774	1	Bedknife-HOC, Low	27	3234-11	8	Screw-HHF
11:3	57-4910	8	Screw	28	323-7	4	Screw-HH
12	93-7502	2	Bushing-Flanged	29	93-7522	2	Screw-HH
13	100-2289	1	Rear Grass Shield ASM	30	32121-69	4	Pin-Spring
13:2	98-3999	4	Flap - Side	31	95-2793	1	Nut-Adjustment, Bearing
13:3	700382	12	Rivet	32	94-2703	1	Plug
14	100-4994-01	1	Frame-Reel	33	100-4987	1	Screw-HS
15	62-5510	2	Bushing-Rubber	34	93-9795	1	LH Bearing Housing ASM
16	3296-39	12	Nut-Lock, NI	34:2	93-9793	1	Ring - Seal
17	100-9900	1	Front Grass Shield ASM				
17:2	67-7960	1	Decal-Danger				

* Not illustrated

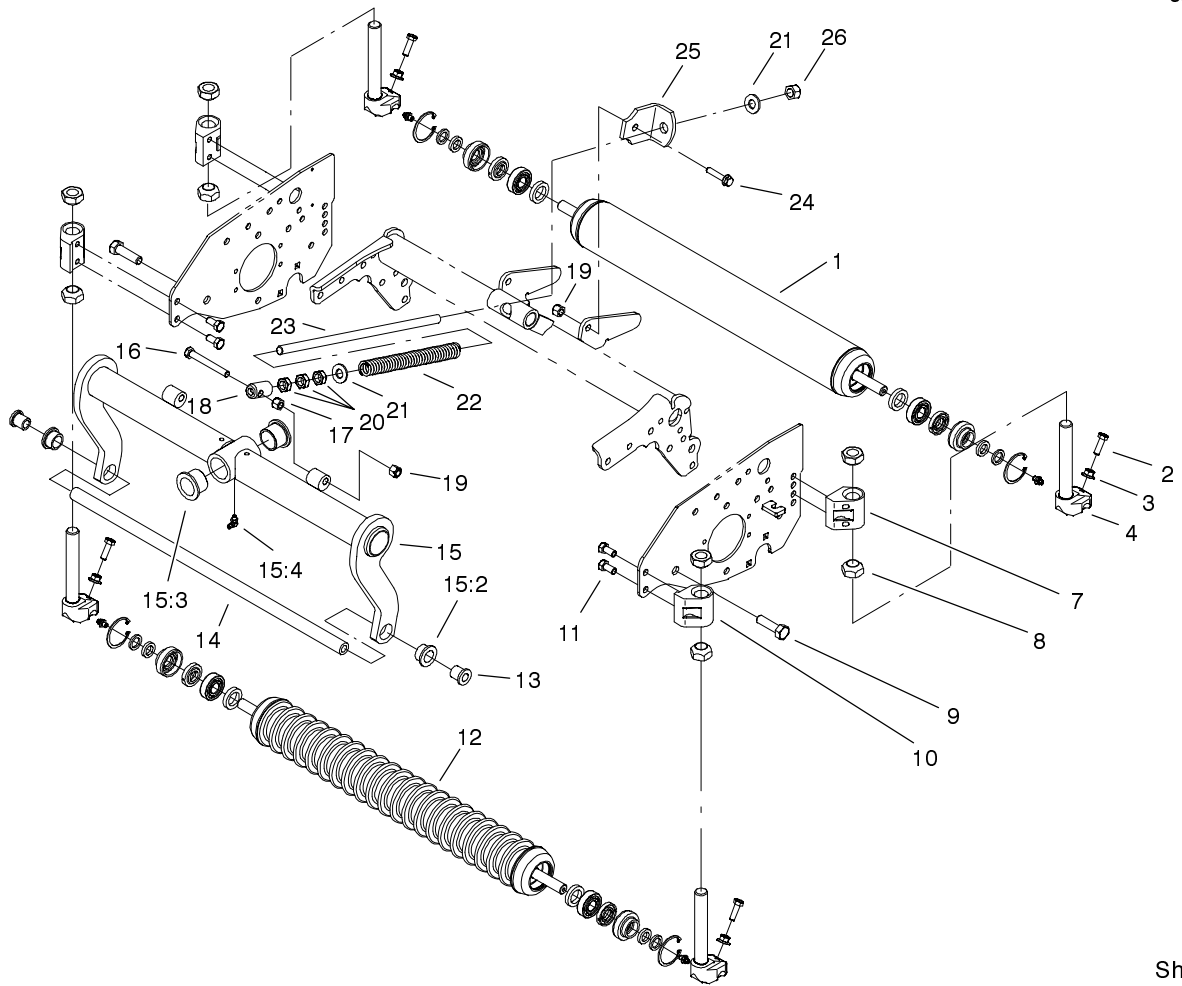

Sheet No.:3

Rollers and Carrier Frame Assembly

Ref. No.	Part No.	Qty.	Description
1	99-5749	1	3" Dia Roller ASM
2	322-5	4	Screw-HH
3	32128-20	4	Nut-HF
4	100-2263	4	Support-Rod
7	100-2262-01	2	Bracket-HOC, Rear
*8	95-2790	1	Nut-Cone, Tall
8	95-2789	8	Nut-Cone
9	325-7	2	Screw-HH
10	100-2261-01	2	Bracket-HOC, Front
11	323-4	8	Screw-HH
12	100-9906	1	Wiehle Roller ASM
*12	99-8675	1	Shoulder Roller ASM
*12	100-9911	1	Shoulder Roller ASM
13	100-2276	2	Spacer-Frame
14	99-8693	1	Rod-Support
15	100-8011	1	Carrier Frame ASM
15:2	93-2877	2	Bushing
15:3	94-1291	2	Bushing-Special
15:4	302-60	1	Fitting-Lube
16	99-8664	1	Screw-HH
17	32128-43	1	Nut-Flange
18	99-8662	1	Tube - Spring
19	3296-39	2	Nut-Lock, NI
20	3218-5	3	Nut-Jam
21	87-7270	2	Washer - Thrust
22	92-7768	1	Spring-Compression

Ref. No.	Part No.	Qty.	Description
23	99-8661	1	Rod - Spring
24	3234-18	1	Screw-HHF
25	100-4992	1	Bracket-Spring
26	3296-23	1	Nut-Lock, NI

* Not illustrated

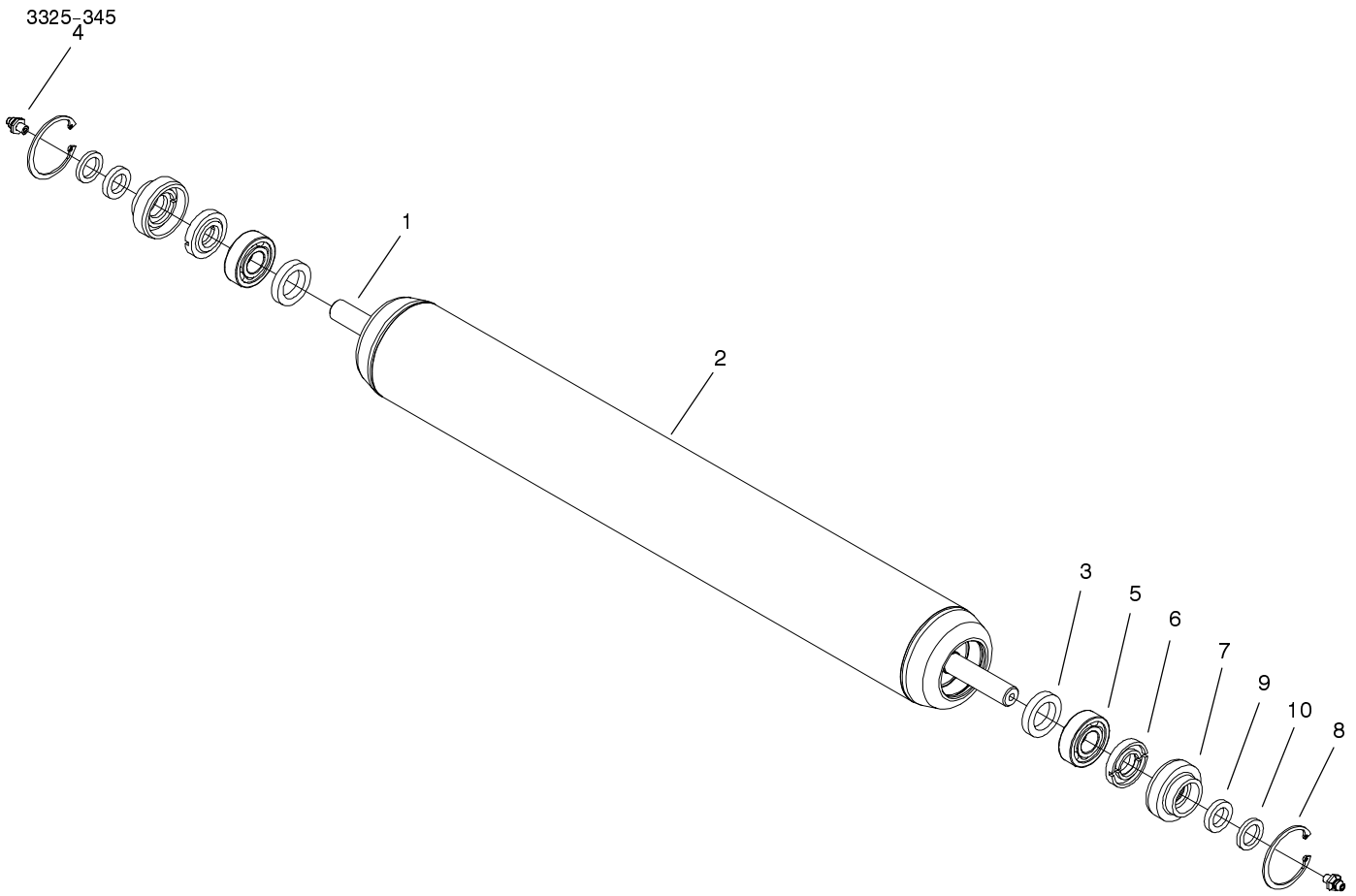

Sheet No.:A1

Full Roller Assembly No. 99-5749

Ref. No.	Part No.	Qty.	Description
1	99-5748	1	Shaft-Roller
2	100-9943-03	1	3" Dia Roller Tube ASM
3	93-3007	2	Seal-Oil
4	302-5	2	Fitting-Grease
5	109966	2	Bearing-Ball
6	93-1251	2	Seal-Inner
7	93-1252	2	Seal-Outer
8	32120-62	2	Ring-Retaining
9	253-70	2	Seal - Oil
10	93-2931	2	Washer-Roller

Ref. No.	Part No.	Qty.	Description

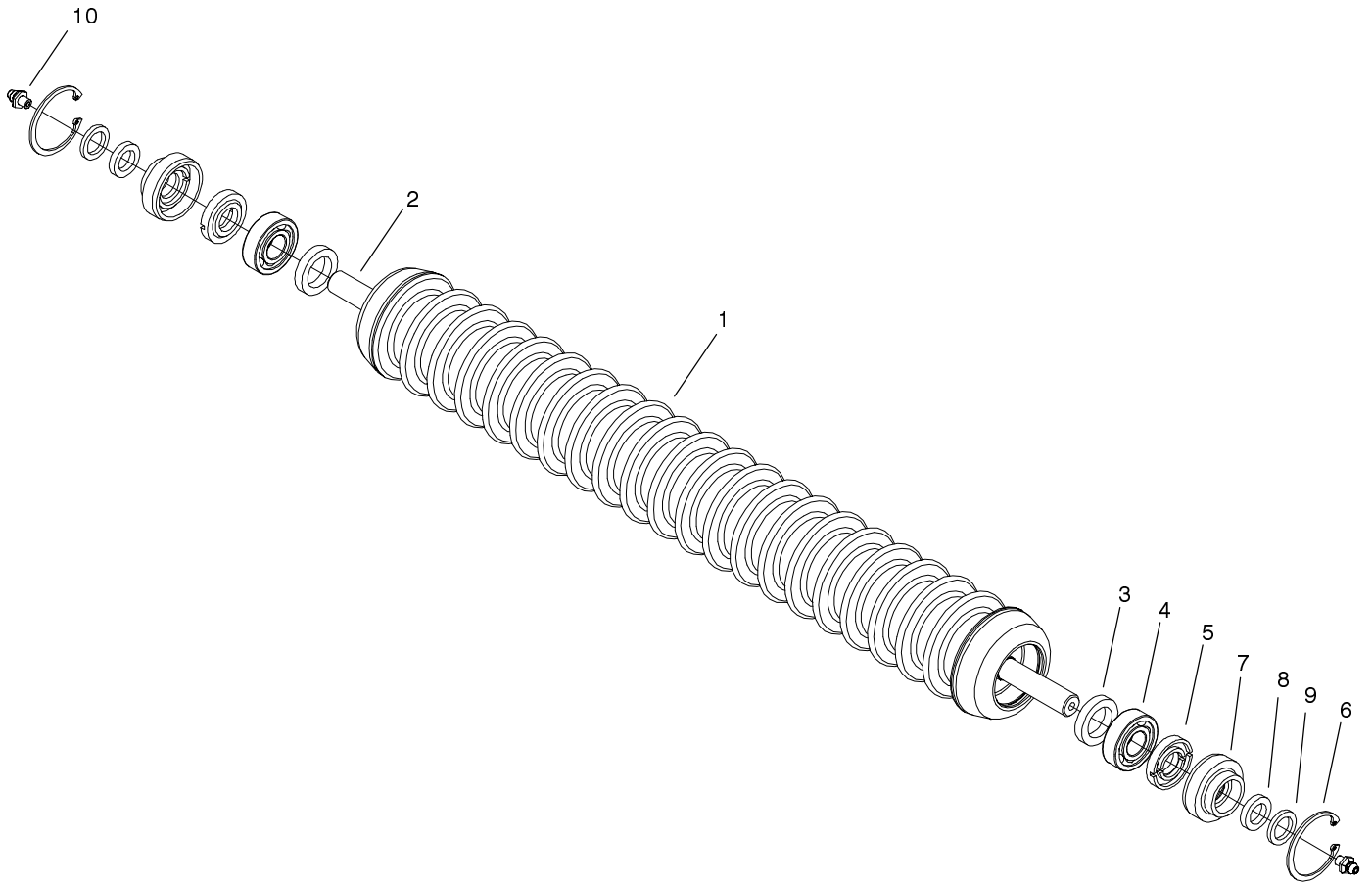

Sheet No.:A2

Wiehle Roller Assembly No. 100-9906

Ref. No.	Part No.	Qty.	Description
1	100-9905-03	1	Wiehle Roller ASM
2	99-5748	3	Shaft-Roller
3	93-3007	6	Seal-Oil
4	109966	2	Bearing-Ball
5	93-1251	2	Seal-Inner
6	32120-62	2	Ring-Retaining
7	93-1252	2	Seal-Outer
8	253-70	2	Seal - Oil
9	93-2931	2	Washer-Roller
10	302-5	2	Fitting-Grease

Ref. No.	Part No.	Qty.	Description

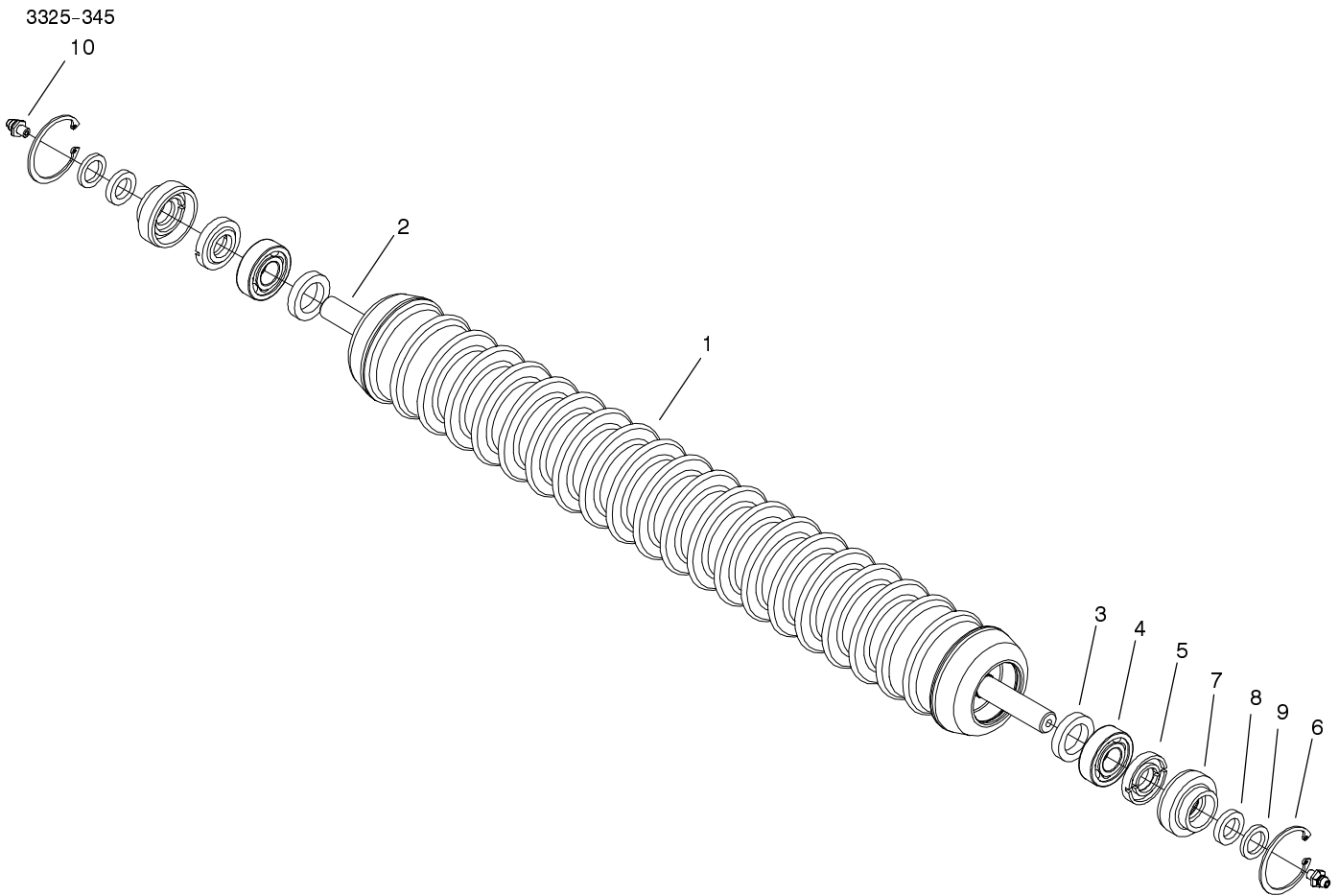

Sheet No.:A3

Shoulder Roller Assembly No. 100-9911 (RM5500)

Ref. No.	Part No.	Qty.	Description
1	100-9910-03	1	Shoulder Weihle Roller ASM
2	99-5748	1	Shaft-Roller
3	93-3007	2	Seal-Oil
4	302-5	4	Fitting-Grease
5	109966	4	Bearing-Ball
6	93-1251	4	Seal-Inner
7	32120-62	4	Ring-Retaining
8	93-1252	4	Seal-Outer
9	253-70	4	Seal - Oil
10	93-2931	4	Washer-Roller

Ref. No.	Part No.	Qty.	Description

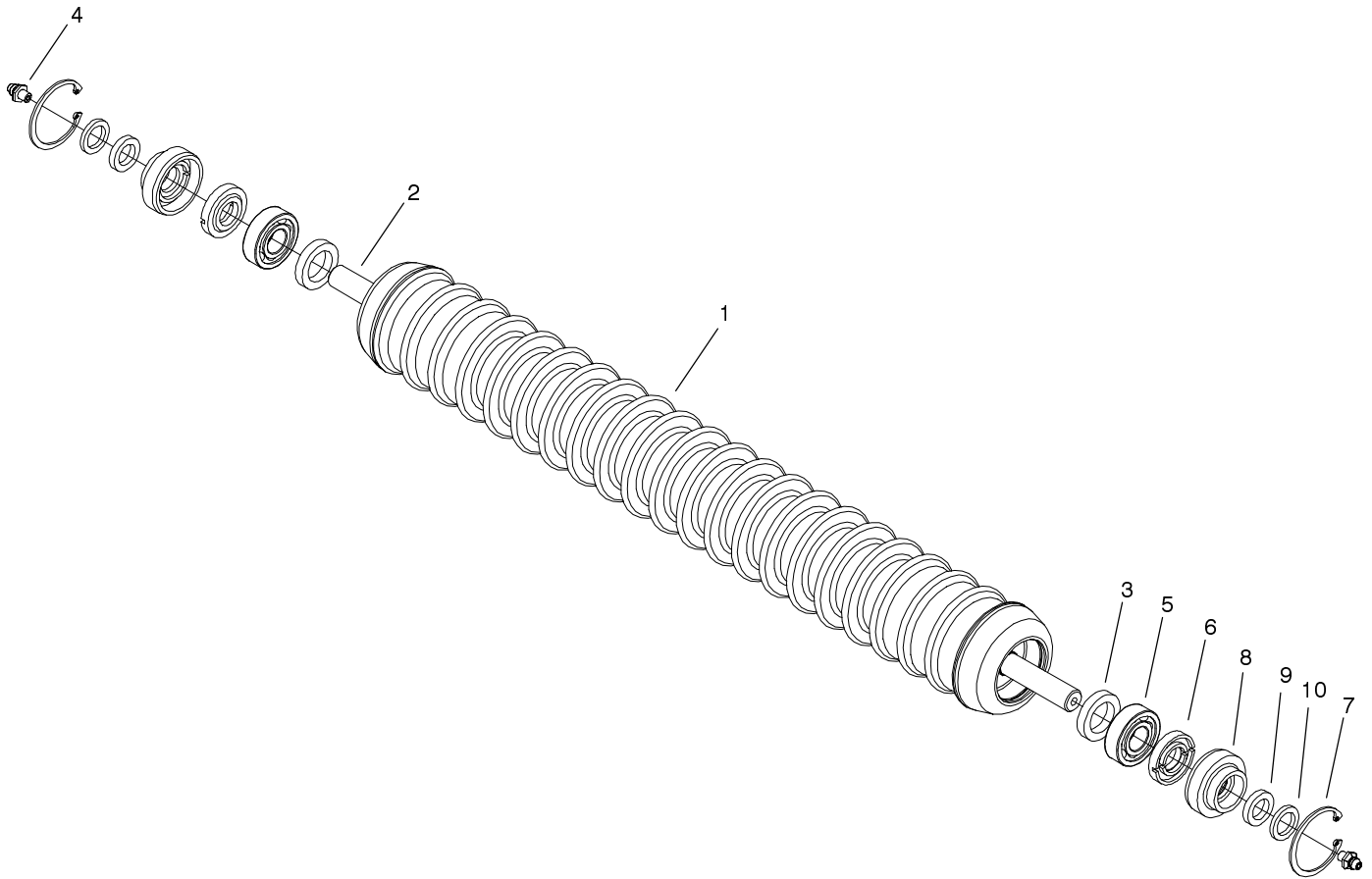

Sheet No.:A4

Shoulder Roller Assembly No. 99-8675 (RM6000 Series)

Ref. No.	Part No.	Qty.	Description
1	99-8674-03	1	Shoulder Wiehle Roller ASM
2	99-5748	1	Shaft-Roller
3	93-3007	2	Seal-Oil
4	302-5	4	Fitting-Lube
5	109966	4	Bearing-Ball
6	93-1251	4	Seal-Inner
7	32120-62	4	Ring-Retaining
8	93-1252	4	Seal-Outer
9	253-70	4	Seal-Oil
10	93-2931	4	Washer-Roller

Ref. No.	Part No.	Qty.	Description

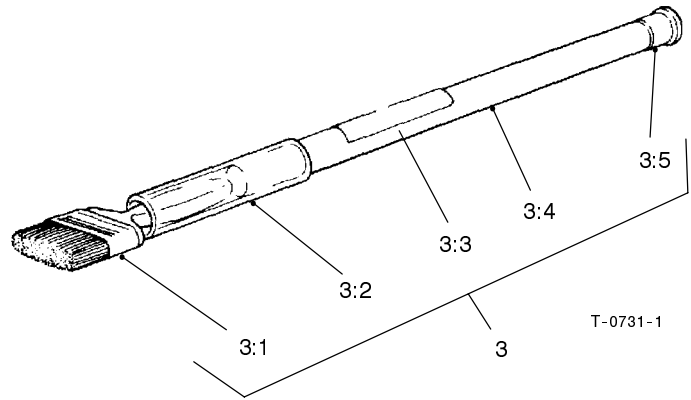
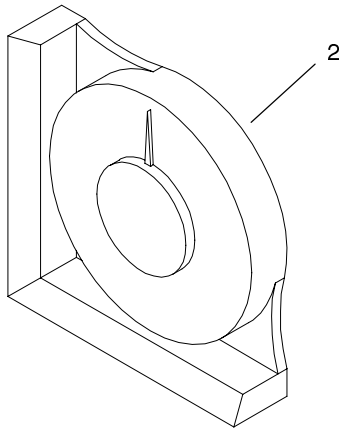
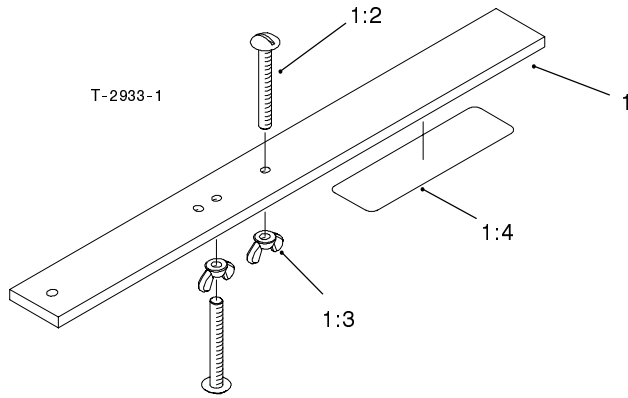

Sheet No.:45

Guage Bar, Angle Indicator and Handle Assembly

Ref. No.	Part No.	Qty.	Description
1	98-1852	1	Gauge Bar ASM
1:2	32122-54	2	Screw-Head, Truss
1:3	32103-3	2	Nut-Wing
1:4	98-7976	1	Decal-Bar, Gauge
2	99-3503	1	Indicator-Angle
3	29-9100	1	Handle ASM
3:1	36-4310	1	Brush
3:2	29-9090	1	Hose-Handle
3:3	12-9140	1	Decal-Body, Front
3:4	29-9080	1	Handle
3:5	2410-18	1	Cap-Plastic

Ref. No.	Part No.	Qty.	Description

