



## **Cutting Unit**

### **Greensmaster<sup>®</sup> 3000**

**Model No. 04404—210000001 and Up**

**Model No. 04406—210000001 and Up**

**Model No. 04408—210000001 and Up**

**Operator's Manual**

# Contents

	Page
Introduction .....	2
Optional Equipment .....	3
Setup .....	3
Loose Parts .....	3
Adjusting the Bedknife to the Reel .....	4
Adjusting the Shield Height .....	5
Adjusting the Top Bar .....	5
Adjusting the Height of Cut .....	6
Maintenance .....	6
Lubrication .....	6
Reel Lapping .....	6
Removing the Bedknife for Grinding .....	7
Preparing the Reel for Grinding .....	7
Servicing and Adjusting the Reel Bearings .....	8
Removing the Reel Assembly .....	9
Leveling the Rear Roller Assembly to the Reel ..	9
The Toro General Commercial Products Warranty ..	12

## Introduction

Thank you for purchasing a Toro product.

All of us at Toro want you to be completely satisfied with your new product, so feel free to contact your local Authorized Service Dealer for help with service, genuine replacement parts, or other information you may require.

Whenever you contact your Authorized Service Dealer or the factory, always know the model and serial numbers of your product. These numbers will help the Service Dealer or Service Representative provide exact information about your specific product. You will find the model and serial number plate at the location shown in Figure 1.

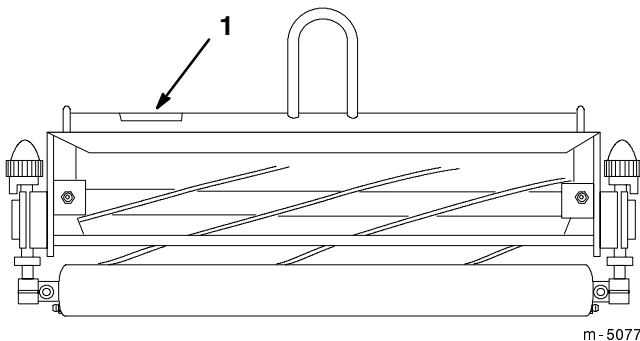

**Figure 1**

1. Model and serial number plate

For your convenience, write the product model and serial numbers in the space below.

<b>Model No:</b> _____
<b>Serial No.</b> _____

Read this manual carefully to learn how to operate and maintain your product correctly. Reading this manual will help you and others avoid personal injury and damage to the product. Although we design, produce and market safe, state-of-the-art products, you are responsible for using the product properly and safely. You are also responsible for training persons, who you allow to use the product, about safe operation.

The warning system in this manual identifies potential hazards and has special safety messages that help you and others avoid personal injury, even death. **Danger**, **Warning**, and **Caution** are signal words used to identify the level of hazard. However, regardless of the hazard, be extremely careful.

**Danger** signals an extreme hazard that will cause serious injury or death if the recommended precautions are not followed.

**Warning** signals a hazard that may cause serious injury or death if the recommended precautions are not followed.

**Caution** signals a hazard that may cause minor or moderate injury if the recommended precautions are not followed.

Two other words are also used to highlight information. **Important** calls attention to special mechanical information, and **Note** emphasizes general information worthy of special attention.

Determine the left and right side of the machine from the normal operating position.

# Optional Equipment

Swaged Roller Kit	Model No. 04414
Full Roller Kit	Model No. 04412
Wihle Roller Kit	Model No. 04424
Aluminum Wihle Roller Kit	Model No. 04426
Rear Roller Cleaner	Part No. 42-4820
Basket Reinforcement Kit	Part No. 26-0900
Variable Quick Height-of-Cut Kit	Part No. 24-9400
Quick Height-of-Cut Kit	Part No. 29-5910
Scraper Comb Assembly	Part No. 11-0700
Tournament Bedknife	Part No. 63-8550
Lo-Cut Bedknife	Part No. 63-8500
Hi-Cut Bedknife	Part No. 62-2510
Fairway Bedknife	Part No. 63-8610
Scraper/Brush Assembly	Part No. 33-1000

## Setup

### Loose Parts

Description	Qty.	Use
Ball stud	2	Mount the front roller.
Internal tooth lock washer—3/8 in.	2	
Flange locknut	2	Mount the reel drive motor to the cutting unit.
Registration card	1	Fill out and return to Toro.

1. The cutting unit is shipped without a front roller. Install the roller using the loose parts supplied with the cutting unit and the instructions included with the roller.
2. Retain the two flange nuts supplied in the loose parts for mounting the reel drive motor to the cutting unit.
3. Check for looseness in the bearings between the end plate and reel by moving the reel laterally or axially on each end of the cutting unit; refer to Servicing and Adjusting the Reel Bearings, page 8.
4. Check the drive end of the reel for grease. Grease should be visibly evident.
5. Ensure that all nuts and bolts are securely fastened.
6. Check the level of the rear roller to the reel; refer to Leveling the Rear Roller Assembly to the Reel, page 9.

# Adjusting the Bedknife to the Reel

1. Loosen the bottom adjustment screw on each side of the cutting unit (Fig. 2). Then tighten the top adjustment screw on each side of the cutting unit (Fig. 3). This adjustment will position the bedknife closer to the reel blades.

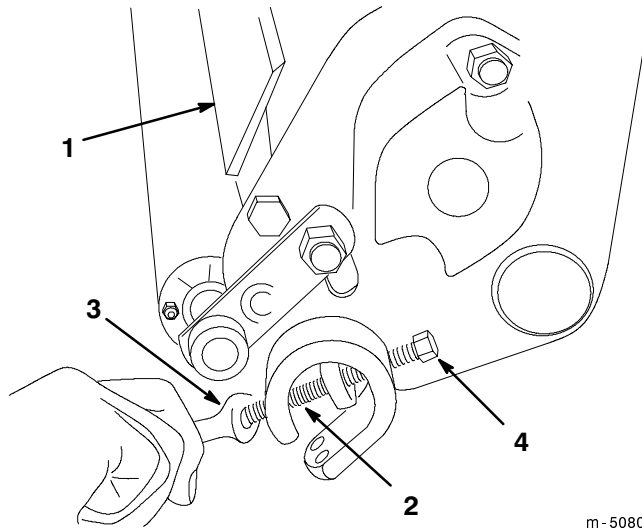

**Figure 2**

- |                            |                         |
|----------------------------|-------------------------|
| 1. Bedknife                | 3. 3/8 in. wrench       |
| 2. Bottom adjustment screw | 4. Top adjustment screw |

m-5080

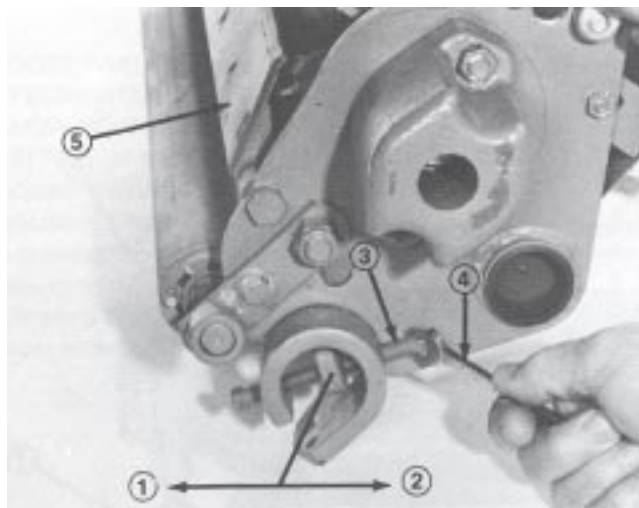
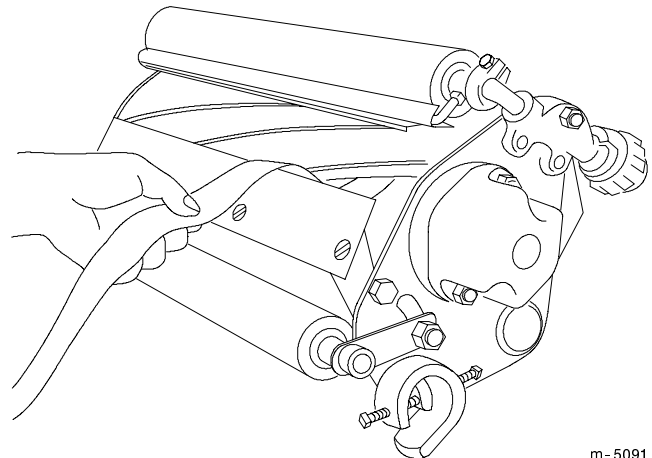

**Figure 3**

- |                               |                   |
|-------------------------------|-------------------|
| 1. Bedknife closer to reel    | 4. 3/8 in. wrench |
| 2. Bedknife further from reel | 5. Bedknife       |
| 3. Top adjustment screw       |                   |

**Important** Use only an open end wrench 3 to 6 in. (7.6 to 15.2 cm) in length for adjusting the bedknife to the reel. A longer wrench will provide too much leverage and may cause distortion of the mounting plate for the adjustment screws.

2. After adjusting the bedknife to the reel, make sure that both the top and bottom adjustment screws are secured on both ends of the cutting unit (Fig. 2 and 3).
3. After the adjustment is accomplished, check to see if the reel can pinch a piece of paper when it is inserted from the front and cut the paper when it is inserted at a right angle (Fig. 4). It should be possible to cut the paper with minimum contact between the bedknife and the reel blades. If the reel drag is more than 7 in.-lb. (0.8 N•m), either back lap or regrind the cutting unit to achieve the sharp edges needed for precision cutting (see the Toro Sharpening Reel and Rotary Mowers Manual, Form No. 80-300PT).



**Figure 4**

m-5091

## Adjusting the Shield Height

Adjust the shield to ensure grass clipping discharge into the basket properly.

1. Set the cutting unit in the normal cutting position and measure the distance from the top of the front crossbar to the shield at each end of the cutting unit (Fig 5).

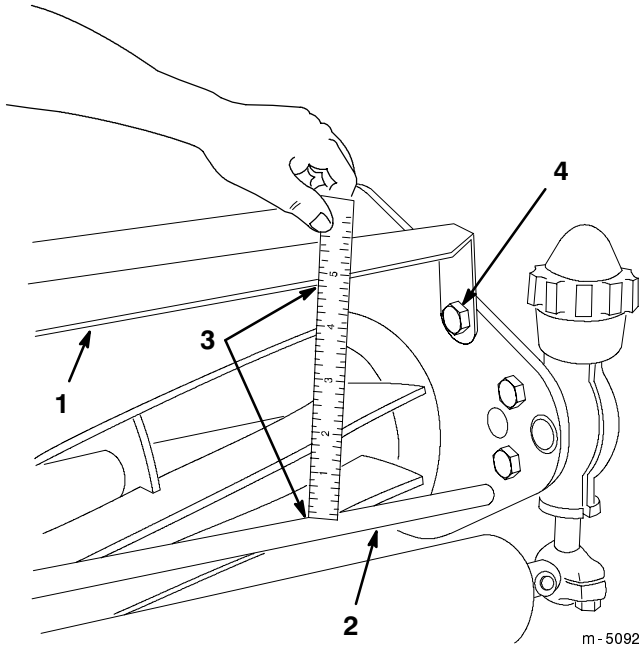

**Figure 5**

1. Shield
2. Front crossbar
3. 4-3/4 in. (12.1 cm)
4. Shield fasteners

2. For normal cutting conditions, the height of the shield from the crossbar should be 4-3/4 in. (12.1 cm). Loosen the screws and nuts securing the shield to each side plate, adjust the shield to the correct height, and tighten the fasteners (Fig. 5).
3. Repeat the adjustment on the remaining cutting units and adjust the top bar; refer to Adjusting the Top Bar, page 5.

**Note:** The shield can be lowered in dry grass conditions (clippings fly over the top of the baskets) or raised to allow for heavy wet grass conditions (clippings build up on the rear edge of the baskets).

## Adjusting the Top Bar

Adjust the top bar to ensure clippings are cleanly discharged from the reel area.

1. Loosen the screws securing the top bar (Fig. 6). Insert a 0.06 in. (1.5 mm) feeler gauge between the top of the reel and bar and tighten the screws (Fig. 6). Ensure that the bar and reel are an equal distance apart across the complete reel.

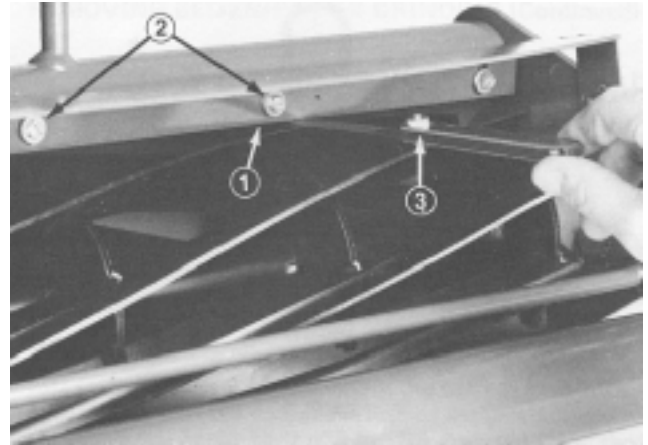

**Figure 6**

1. Top bar
2. Bar mounting screws
3. Feeler gauge

2. Repeat the settings on the remaining cutting units.

**Note:** The bar is adjustable to compensate for changes in turf conditions. The bar should be adjusted closer to the reel when the turf is extremely wet and further away from the reel when the turf conditions are dry. The bar should be parallel to the reel to ensure optimum performance and should be adjusted whenever the shield height is adjusted or whenever the reel is sharpened on a reel grinder.

## Adjusting the Height of Cut

- For adjusting the cutting unit height of cut 1/4 in. (6 mm) or below, set the rear roller in the lowest height-of-cut position; refer to Leveling the Rear Roller Assembly to the Reel, page 9. To adjust the height of cut, turn the cutting unit over and loosen the locknuts on each end of the cutting unit securing the height-of-cut adjusting knob (Fig. 7).

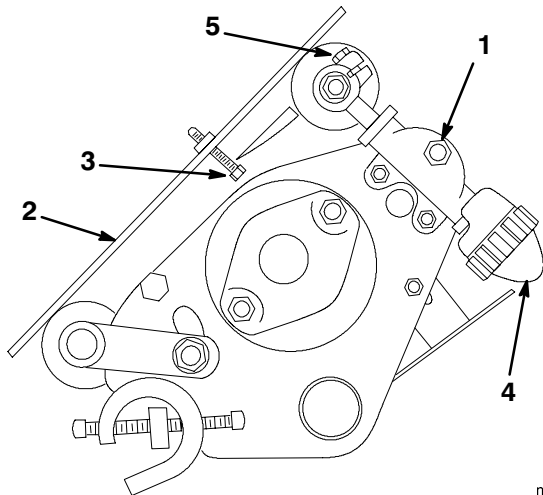

m-5090

**Figure 7**

- |                                |                            |
|--------------------------------|----------------------------|
| 1. Height-of-cut knob locknut  | 3. Gauge bar screw head    |
| 2. Gauge Bar (Part No. 1-8789) | 4. Height-of-cut knob      |
|                                | 5. Roller shaft clamp bolt |

- On the gauge bar (Part No. 1-8789), set the head of the screw to the desired height of cut. This measurement is from the bar face to the underside of the screw head.
- Place the bar across the front and rear rollers and adjust the height-of-cut knob until the underside of the screw head engages the bedknife cutting edge (Fig. 6).

**Important** Perform step 3 on each end of the bedknife. Tighten the height-of-cut adjustment locknuts on both ends.

## Maintenance

**Important** To prevent damage to the hydraulic hoses, remove the reel motors before removing the cutting units.

### Lubrication

There are six grease fittings on each cutting unit (Fig. 8 and 9) that should be greased at least once every two weeks. Lubricate them using a No. 2 multipurpose lithium-based grease. For best results, use a hand-operated grease gun.

- Wipe each grease fitting with a clean rag.
- Grease the reel bearings (Fig. 8) as follows:
  - Hydraulic motor end—apply grease until pressure is felt against the handle.
  - Counterbalance end—apply grease until it starts to come through the seal inside the counterbalance hole.

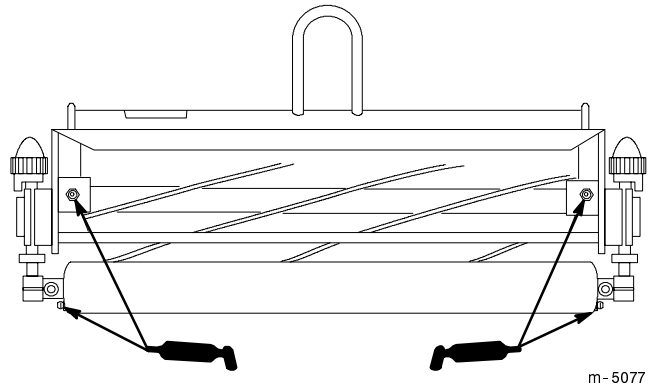

**Figure 8**

- Apply grease to the front and rear roller bearings (Fig. 8 and 9) until it begins to show around the seal lips.

**Important** Do not apply too much pressure or the grease seals will be permanently damaged.

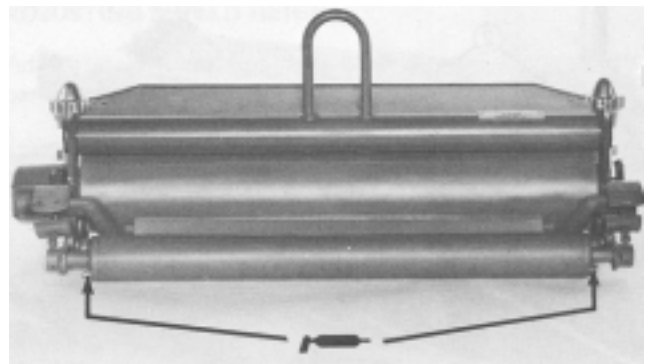

**Figure 9**

- Wipe any excess grease.

### Reel Lapping

Connect a lapping machine to the cutting unit with an extension coupler and a 9/16 in. socket. The 9/16 in. socket can be positioned onto the capscrew on the reel shaft inside the counterbalance weight on the end of the cutting unit. Backlap according to the procedures in the Toro Sharpening Reel and Rotary Mowers Manual, Form No. 80-300PT.

**Note:** For a better cutting edge, run a file across the front face of the bedknife when the lapping operation is completed. This will remove any burrs or rough edges that may have built up on the cutting edge.

! **Caution** !

**Contact with moving parts may cause personal injury.**

- **Keep your body away from the reels during reel lapping.**

## Removing the Bedknife for Grinding

**Important** To prevent damage to the hydraulic hoses, remove the reel motors before removing the cutting units.

The rear roller assembly must be removed before removing the bedknife assembly for sharpening. To remove the rear roller, proceed as follows:

1. Remove the capscrew and nut anchoring the rear roller height-of-cut bracket to the side plate on both ends of the cutting unit (Fig. 10).

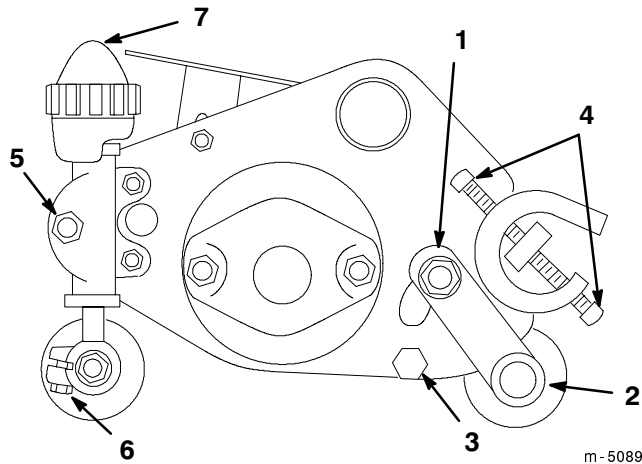

**Figure 10**

- |  |  |
|--|--|
| <ol style="list-style-type: none"> <li>1. Rear roller height-of-cut bracket</li> <li>2. Allen set screw</li> <li>3. Bedbar mounting bolts</li> <li>4. Bedknife adjusting screws</li> </ol> | <ol style="list-style-type: none"> <li>5. Height-of-cut rod locknuts</li> <li>6. Roller shaft clamp bolts</li> <li>7. Height-of-cut adjustment knob</li> </ol> |
|--|--|

2. Loosen the Allen set screws anchoring the roller shaft (Fig. 10).
3. Remove the rear roller height-of-cut brackets from both side plates.
4. Remove the bedbar mounting bolts from each end of the cutting unit (Fig. 10).

5. Loosen the bedknife adjusting screws at each end of the cutting unit (Fig. 10). The bedknife assembly can then be removed by rotating it away from the reel.

**Important** When installing the bedbar assembly, be sure to position the center portion of the grass shield over the rear edge of the bedbar (Fig. 11). Securely seat the two bedbar pivot bolts to a maximum of 40 ft-lb. (54 N•m). Always check the bearing adjustment after assembling the bedbar.

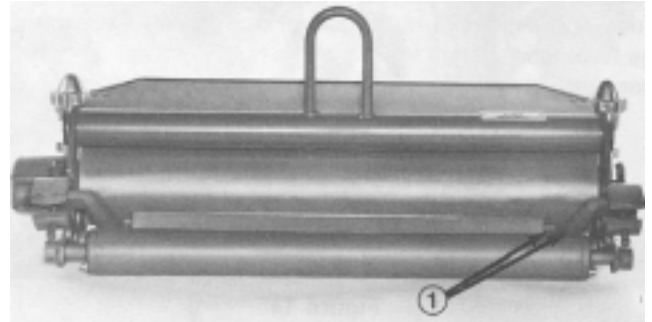

**Figure 11**

1. Bedbar under lip of shield

**Note:** For proper grinding of the bedknife, grind in accordance with the procedures in the Toro Sharpening Reel and Rotary Mowers Manual, Form No. 80-300PT.

## Preparing the Reel for Grinding

**Important** To prevent damage to the hydraulic hoses, remove the reel motors before removing the cutting units.

**Important** Some reel grinders may require that the rear roller assembly be mounted to the cutting unit for proper support in the reel grinder.

The front roller may have to be removed so that the reel can be sharpened. To accomplish this, proceed as follows:

1. Loosen the locknuts securing the height-of-cut adjusting rods at both ends of the cutting unit and the roller shaft clamp bolts (Fig. 10).
2. Turn the height-of-cut adjustment knobs until they are disconnected from the height-of-cut adjusting rods (Fig. 10). The knobs are captivated on the upper washer face of the height-of-cut clamp.
3. Remove the roller assembly from the cutting unit by pulling evenly on both sides.
4. For proper grinding of the reel, grind in accordance with the procedures in the Toro Sharpening Reel and Rotary Mowers Manual, Form No. 80-300PT.

**Important** After the grinding operation is complete, assemble the cutting unit, check the bearing adjustment, and adjust the top shield and bar; refer to Adjusting the Shield Height, page 5, and Adjusting the Top Bar, page 5. Backlap the cutting unit to complete the sharpening operation.

## Servicing and Adjusting the Reel Bearings

**Important** To prevent damage to the hydraulic hoses, remove the reel motors before removing the cutting units.

Periodically check the drag on the reel bearings. They should be checked in the following manner:

1. Adjust the bedknife so it is not in contact with the reel.
2. The reel bearing drag should be from 7 to 11 in.-lb. This can be measured with a torque wrench (Fig. 12).

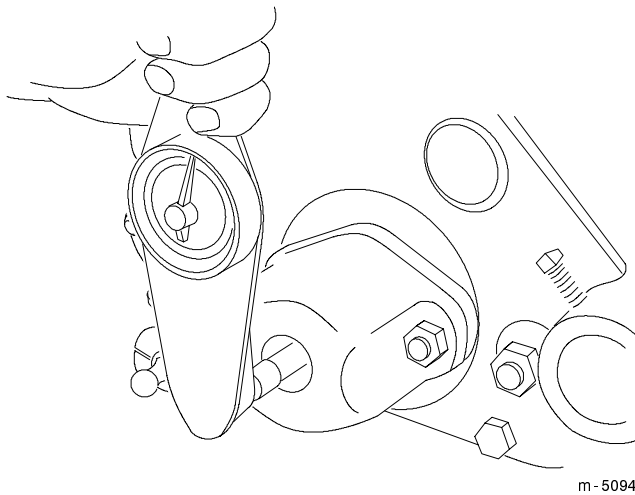

**Figure 12**

If the bearing drag does not meet the above specification, the procedure to adjust the reel bearing drag is as follows:

- A. Remove the mounting nuts from the counterbalance end cap and remove the end cap from the mounting studs (Fig. 13).

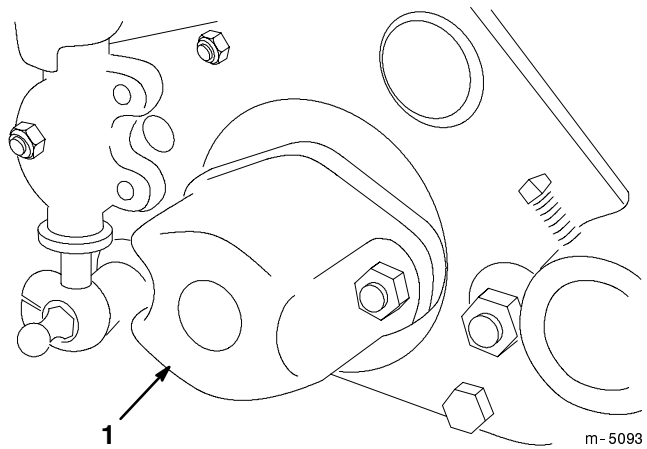

**Figure 13**

1. Counterbalance end cap

- B. Remove the bolt mounted on the end of the reel shaft. This will make it possible for a large socket wrench to be mounted on the reel bearing adjusting nut inside the side plate.
- C. With the wrench mounted, hold the reel and tighten the large reel bearing adjustment nut (Fig. 13). Tighten it until the drag on the reel meets the 7 to 11 in.-lb. specification.
- D. Install the bolt into the end of the reel shaft (Fig. 13) and check the torque with an inch/pound torque wrench.

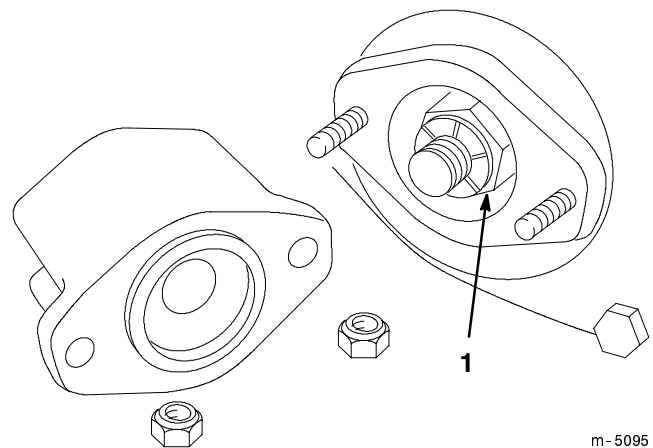

**Figure 14**

1. Reel bearing adjustment nut

## Removing the Reel Assembly

**Important** To prevent damage to the hydraulic hoses, remove the reel motors before removing the cutting units.

1. Remove the front and rear roller assembly.
2. Remove the counterbalance end cap (Fig. 13).
3. Remove the large bearing adjustment nut from one end of the reel shaft (Fig. 12) and the special spline nut at the opposite end of the reel shaft.
4. Remove the mounting bolts from the bearing housing on both ends of the cutting unit (Fig. 15).

**Important** Remove the grease fittings from the bearing housing at each end of the cutting unit. Note that the straight fitting is on the right end and the 90° fitting is on the left end (when viewed in the direction of travel).

5. Using a plastic headed hammer, rotate the bearing housing slightly, install the bearing housing bolts from the outside housing, turn the bolts alternately against the side plate, and remove the bearing housing (Fig. 15).

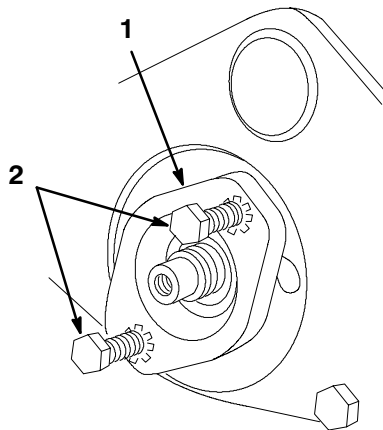

**Figure 15**

1. Bearing housing—rotate slightly
2. Bearing housing mounting bolts—thread against the side plate to remove the housing

6. The bearing housing will slip out of the side plates and the reel assembly can be removed as soon as the bearing housings are disassembled from the side plates.

## Leveling the Rear Roller Assembly to the Reel

1. Mount the rear roller and height-of-cut brackets onto the cutting unit. For height-of-cut settings 1/4 in. (6 mm) or below, set one bracket in the side plate to 1/8 in. (3 mm) from the bottom of the slot and tighten the nut on the capscrew. Leave the bracket on the other side mounted loosely (Fig. 16). For height-of-cut settings above 1/4 in. (6 mm), center the bracket in the slot and tighten the nut.

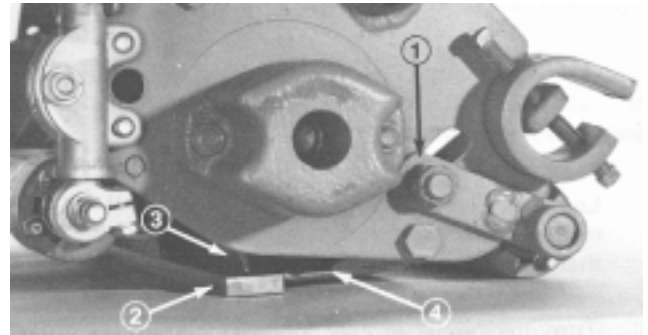

**Figure 16**

1. Rear roller bracket
2. 1/4 in. (6 mm) steel plate
3. Reel blades
4. Bedknife

2. Place a 1/4 in. (6 mm) or thicker plate under the reel blades and against the cutting edge of the bedknife (Fig. 16).

**Note:** Be sure the plate covers the full length of the reel blades.

3. With the cutting unit reel blades positioned on the plate, hold the cutting unit securely and push down on the rear roller assembly until it contacts the working surface across the full length of the roller (Fig. 17).

**Note:** This adjustment should be made on a flat working surface. If the roller does not fully contact the surface because the bracket is bottomed out in the slot, therefore hindering the leveling of the roller, loosen the nut on the roller bracket and move the bracket up in the slot to level the roller on the flat surface. Tighten the nut and proceed to step 4.

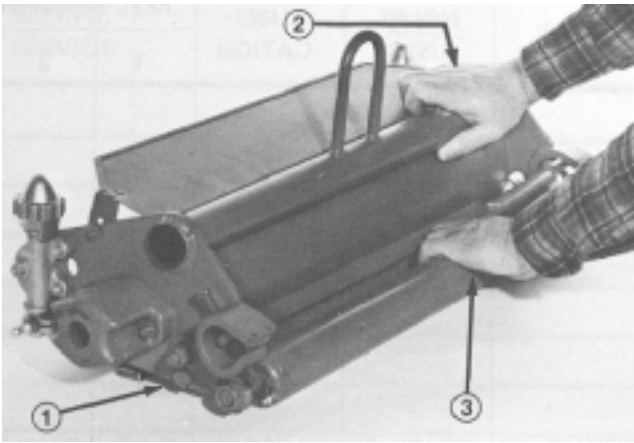

**Figure 17**

1. Unit on a level surface
2. Hold the unit securely
3. Push down on the roller

- 
4. Secure the nut on the outside of the rear roller height-of-cut bracket to lock the roller in place.





# The Toro General Commercial Products Warranty

## A Two-Year Limited Warranty

### Conditions and Products Covered

The Toro Company and its affiliate, Toro Warranty Company, pursuant to an agreement between them, jointly warrant your 1996 or newer Toro Commercial Product ("Product") purchased after January 1, 1997, to be free from defects in materials or workmanship for two years or 1500 operational hours\*, whichever occurs first. Where a warrantable condition exists, we will repair the Product at no cost to you including diagnosis, labor, parts, and transportation. This warranty begins on the date the Product is delivered to the original retail purchaser.

\* Product equipped with hour meter

### Instructions for Obtaining Warranty Service

You are responsible for notifying the Commercial Products Distributor or Authorized Commercial Products Dealer from whom you purchased the Product as soon as you believe a warrantable condition exists.

If you need help locating a Commercial Products Distributor or Authorized Dealer, or if you have questions regarding your warranty rights or responsibilities, you may contact us at:

Toro Commercial Products Service Department  
Toro Warranty Company  
8111 Lyndale Avenue South  
Bloomington, MN 55420-1196  
952-888-8801 or 800-982-2740  
E-mail: [commercial.service@toro.com](mailto:commercial.service@toro.com)

### Owner Responsibilities

As the Product owner, you are responsible for required maintenance and adjustments stated in your operator's manual. Failure to perform required maintenance and adjustments can be grounds for disallowing a warranty claim.

### Items and Conditions Not Covered

Not all product failures or malfunctions that occur during the warranty period are defects in materials or workmanship. This express warranty does not cover:

- Product failures which result from the use of non-Toro replacement parts, or from installation and use of add-on, modified, or unapproved accessories.
- Product failures which result from failure to perform required maintenance and/or adjustments.
- Product failures which result from operating the Product in an abusive, negligent or reckless manner.
- Parts subject to consumption through use unless found to be defective. Examples of parts which are consumed, or used up, during normal Product operation include, but are not limited to, blades, reels, bedknives, tines, spark plugs, castor wheels, tires, filters, belts, etc.

### Countries Other than the United States or Canada

Customers who have purchased Toro products exported from the United States or Canada should contact their Toro Distributor (Dealer) to obtain guarantee policies for your country, province, or state. If for any reason you are dissatisfied with your Distributor's service or have difficulty obtaining guarantee information, contact the Toro importer. If all other remedies fail, you may contact us at Toro Warranty Company.

- Failures caused by outside influence. Items considered to be outside influence include, but are not limited to, weather, storage practices, contamination, use of unapproved coolants, lubricants, additives, or chemicals, etc.
- Normal "wear and tear" items. Normal "wear and tear" includes, but is not limited to, damage to seats due to wear or abrasion, worn painted surfaces, scratched decals or windows, etc.

### Parts

Parts scheduled for replacement as required maintenance are warranted for the period of time up to the scheduled replacement time for that part.

Parts replaced under this warranty become the property of Toro. Toro will make the final decision whether to repair any existing part or assembly or replace it. Toro may use factory remanufactured parts rather than new parts for some warranty repairs.

### General Conditions

Repair by an Authorized Toro Distributor or Dealer is your sole remedy under this warranty.

**Neither The Toro Company nor Toro Warranty Company is liable for indirect, incidental or consequential damages in connection with the use of the Toro Products covered by this warranty, including any cost or expense of providing substitute equipment or service during reasonable periods of malfunction or non-use pending completion of repairs under this warranty. Except for the Emissions warranty referenced below, if applicable, there is no other express warranty. All implied warranties of merchantability and fitness for use are limited to the duration of this express warranty.**

Some states do not allow exclusions of incidental or consequential damages, or limitations on how long an implied warranty lasts, so the above exclusions and limitations may not apply to you.

This warranty gives you specific legal rights, and you may also have other rights which vary from state to state.

**Note regarding engine warranty:** The Emissions Control System on your Product may be covered by a separate warranty meeting requirements established by the U.S. Environmental Protection Agency (EPA) and/or the California Air Resources Board (CARB). The hour limitations set forth above do not apply to the Emissions Control System Warranty. Refer to the Engine Emission Control Warranty Statement printed in your operator's manual or contained in the engine manufacturer's documentation for details.